



US 20120130345A1

(19) **United States**
(12) **Patent Application Publication**
LEVIN et al.

(10) **Pub. No.: US 2012/0130345 A1**
(43) **Pub. Date: May 24, 2012**

(54) **RENAL NERVE STIMULATION METHOD FOR TREATMENT OF PATIENTS**

on Oct. 3, 2002, provisional application No. 60/442,970, filed on Jan. 29, 2003.

(75) Inventors: **Howard R. LEVIN**, Teaneck, NJ (US); **Mark Gelfand**, New York, NY (US)

(73) Assignee: **Ardian, Inc.**, Palo Alto, CA (US)

(21) Appl. No.: **13/361,019**

(22) Filed: **Jan. 30, 2012**

Publication Classification

(51) **Int. Cl.**
A61N 1/36 (2006.01)
A61M 25/00 (2006.01)
A61B 18/12 (2006.01)
A61M 5/14 (2006.01)
A61M 31/00 (2006.01)
A61N 1/372 (2006.01)

(52) **U.S. Cl.** **604/506**; 607/2; 604/500; 607/72; 607/62; 606/41; 604/523; 604/93.01

Related U.S. Application Data

(63) Continuation of application No. 11/688,178, filed on Mar. 19, 2007, now Pat. No. 8,131,372, which is a continuation of application No. 11/144,173, filed on Jun. 3, 2005, now Pat. No. 7,647,115, which is a continuation of application No. 10/408,665, filed on Apr. 8, 2003, now Pat. No. 7,162,303.

(60) Provisional application No. 60/370,190, filed on Apr. 8, 2002, provisional application No. 60/415,575, filed

(57) **ABSTRACT**

A method and apparatus for treatment of heart failure, hypertension and renal failure by stimulating the renal nerve. The goal of therapy is to reduce sympathetic activity of the renal nerve. Therapy is accomplished by at least partially blocking the nerve with drug infusion or electrostimulation. Apparatus can be permanently implanted or catheter based.

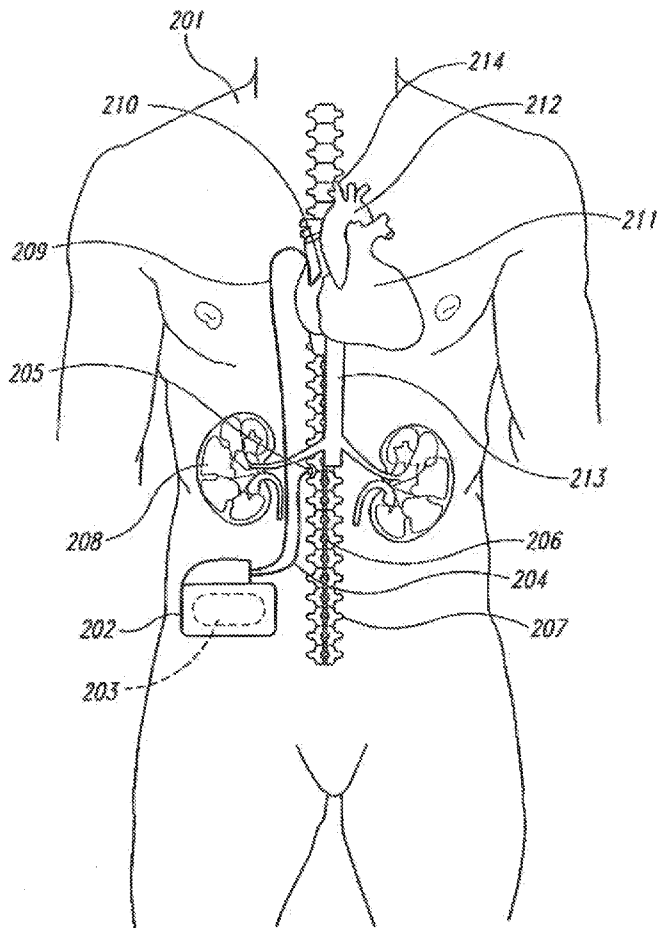

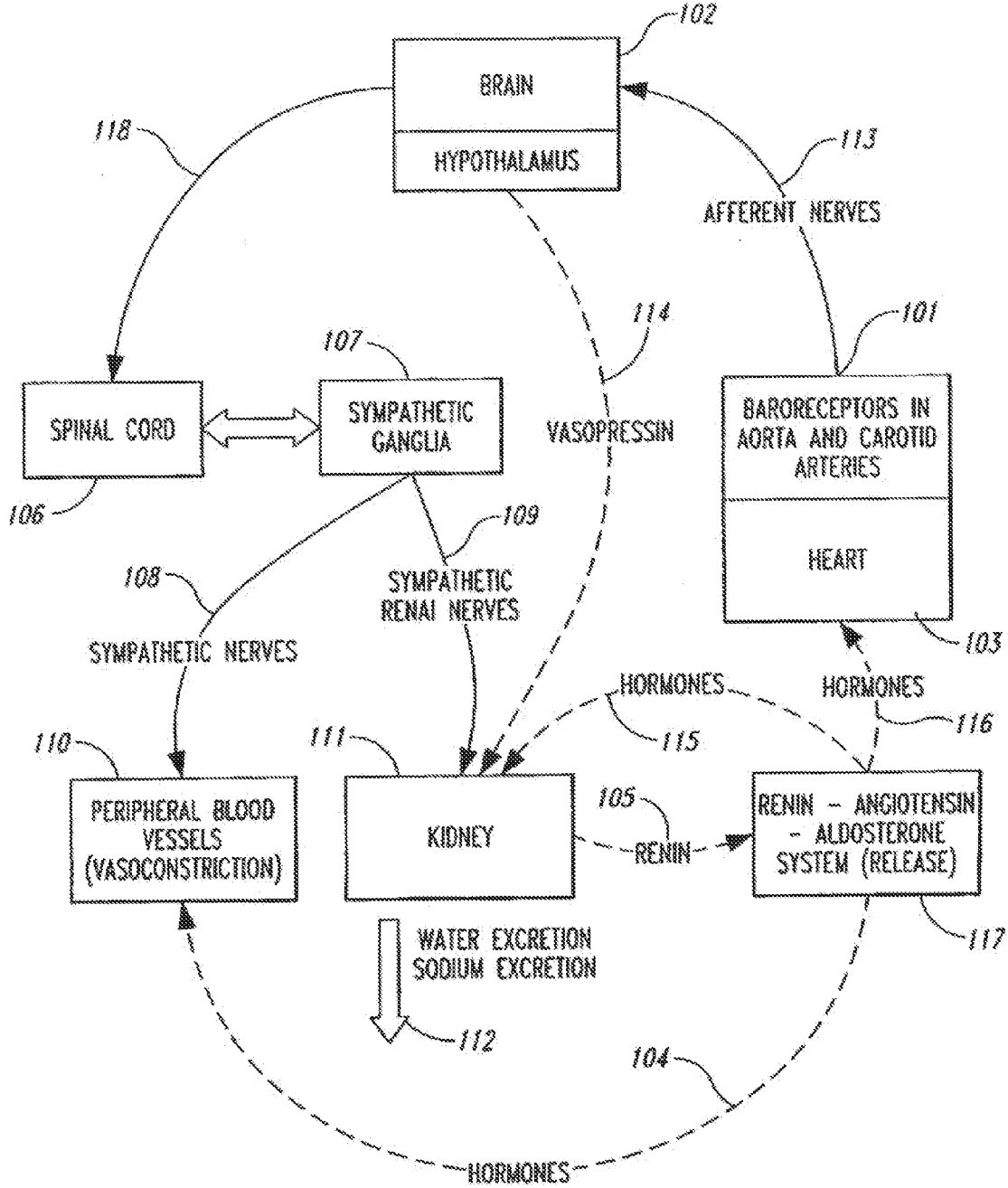

Fig. 1

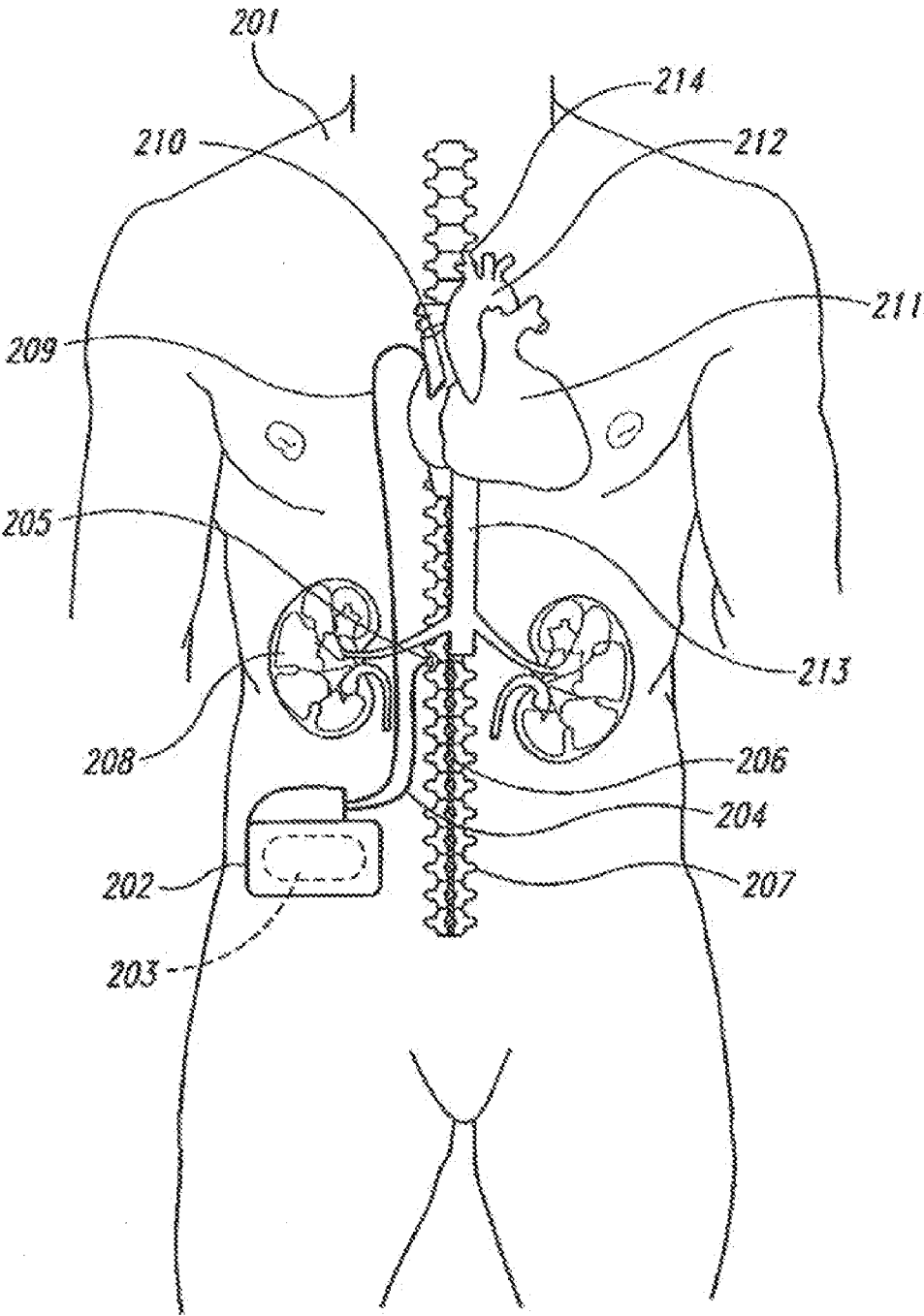

Fig. 2

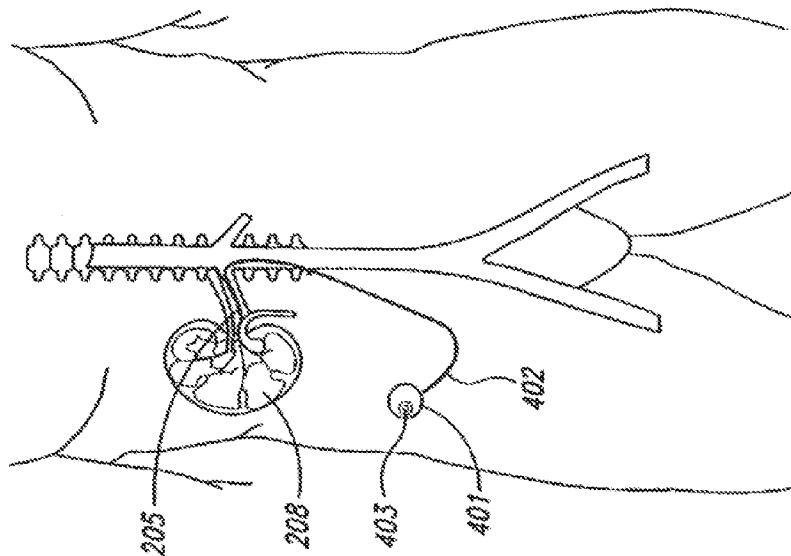

Fig. 3

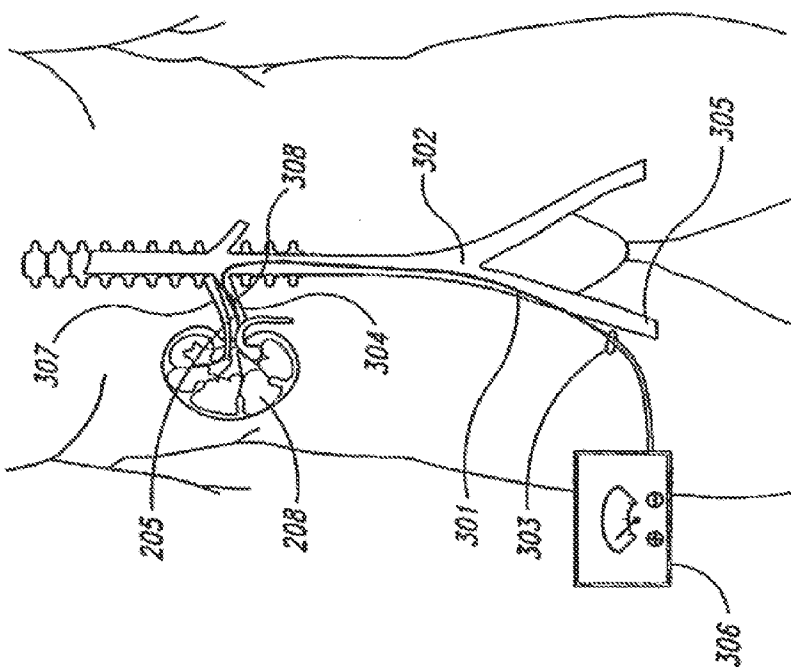

Fig. 4

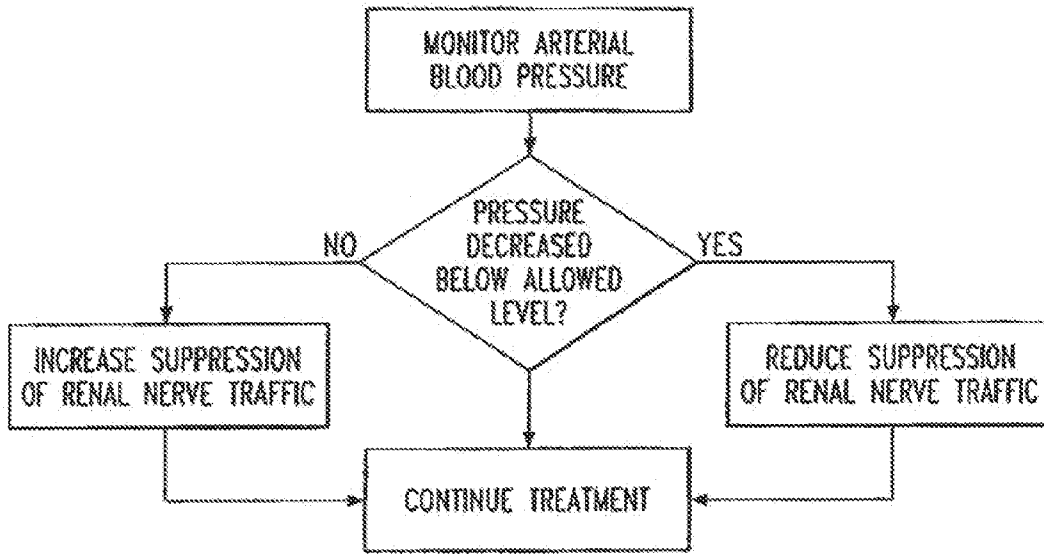

Fig. 5

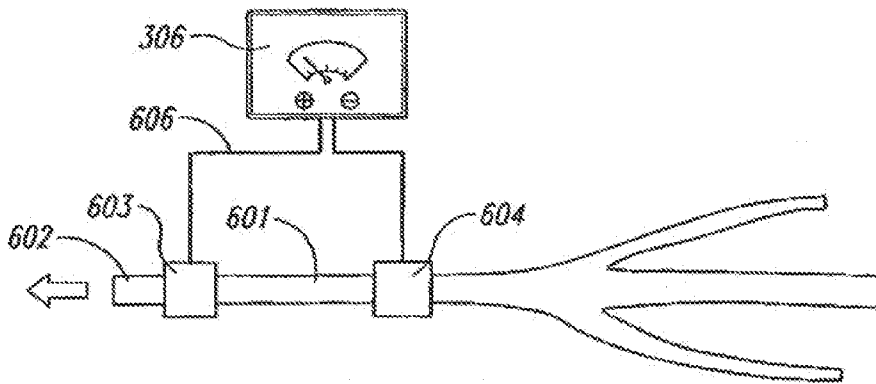

Fig. 6

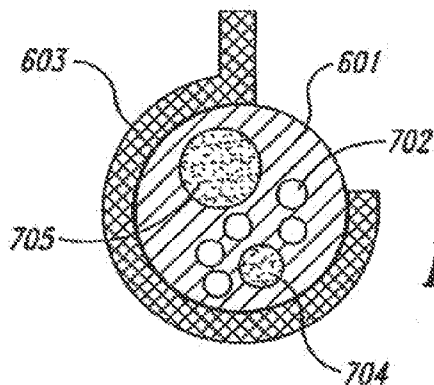

Fig. 7

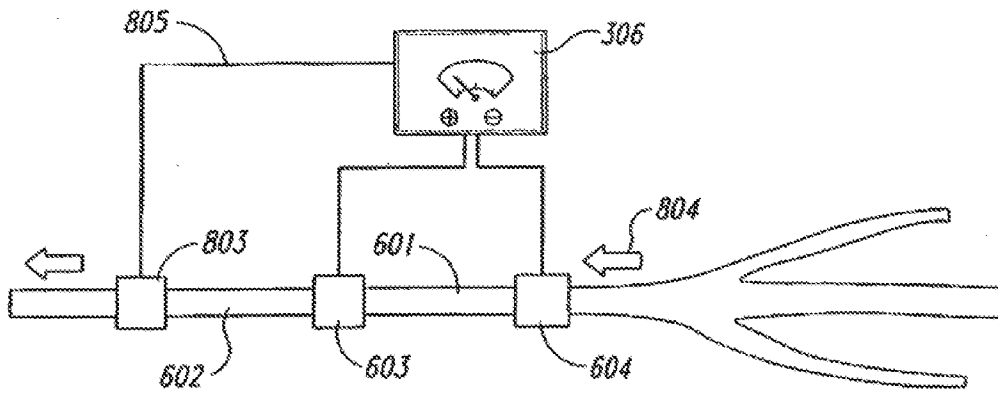

Fig. 8

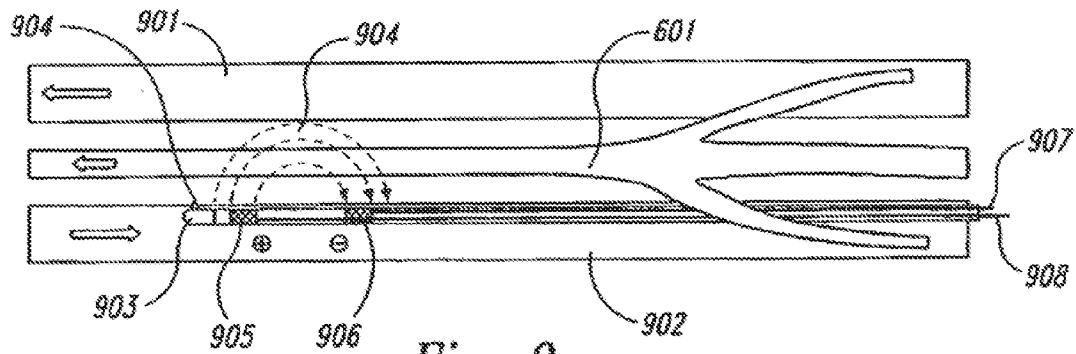

Fig. 9

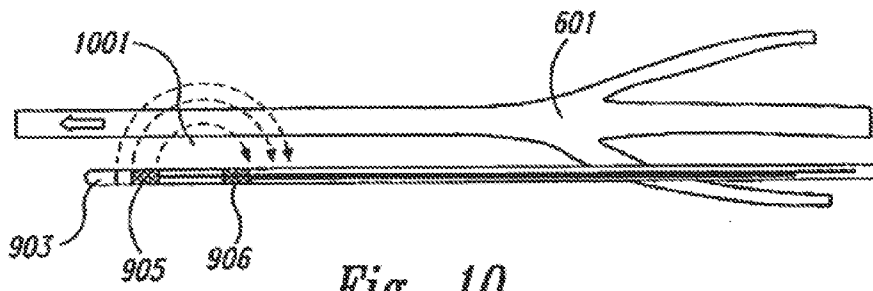

Fig. 10

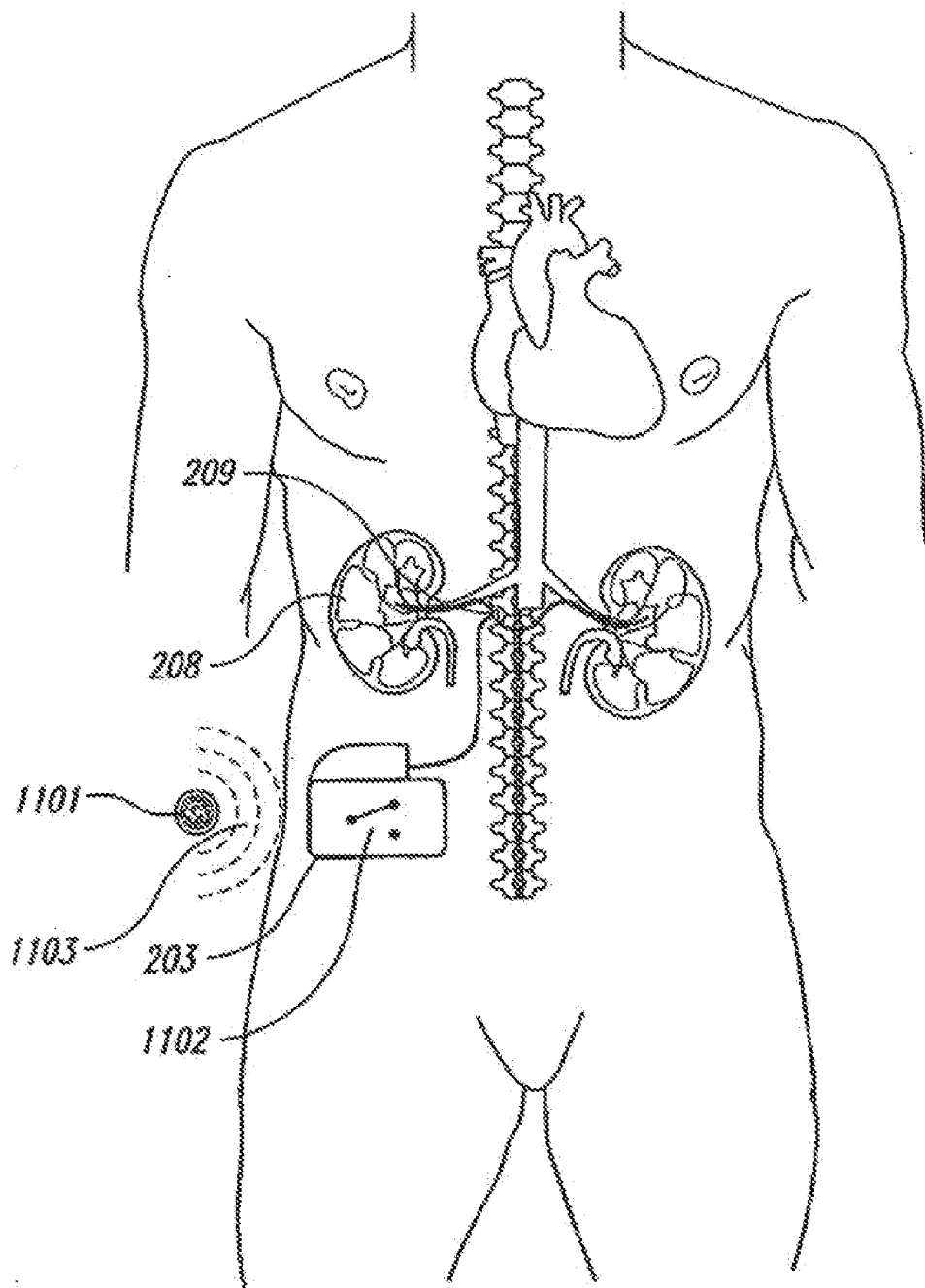

Fig. 11

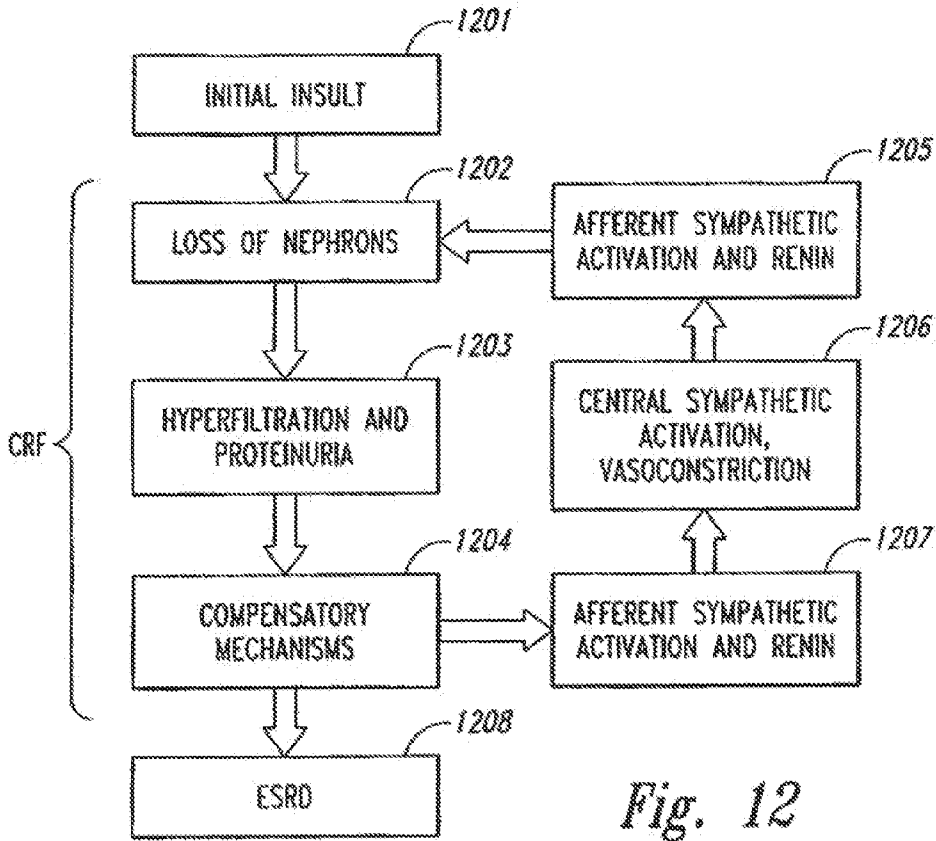

Fig. 12

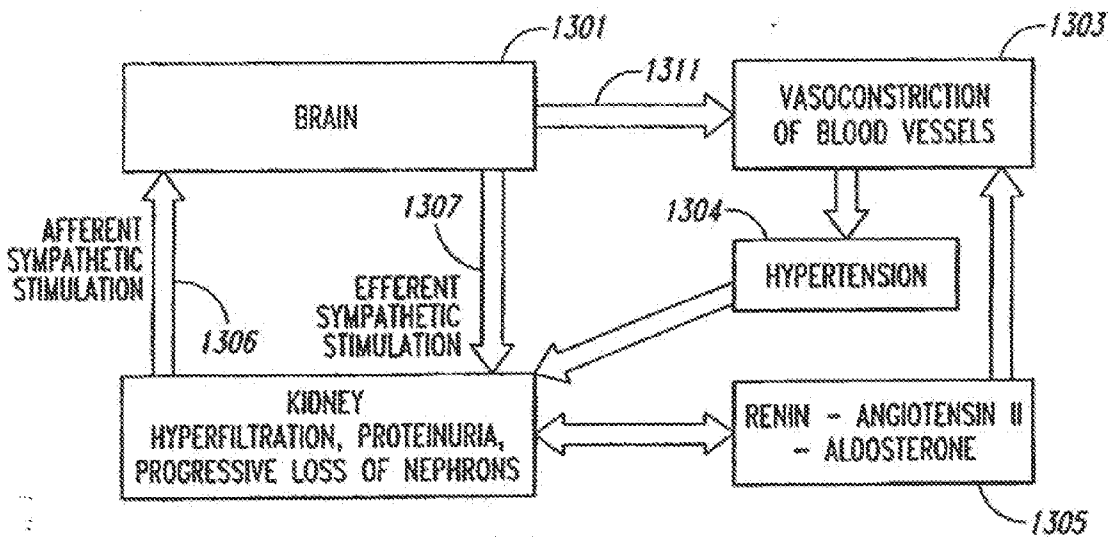

Fig. 13

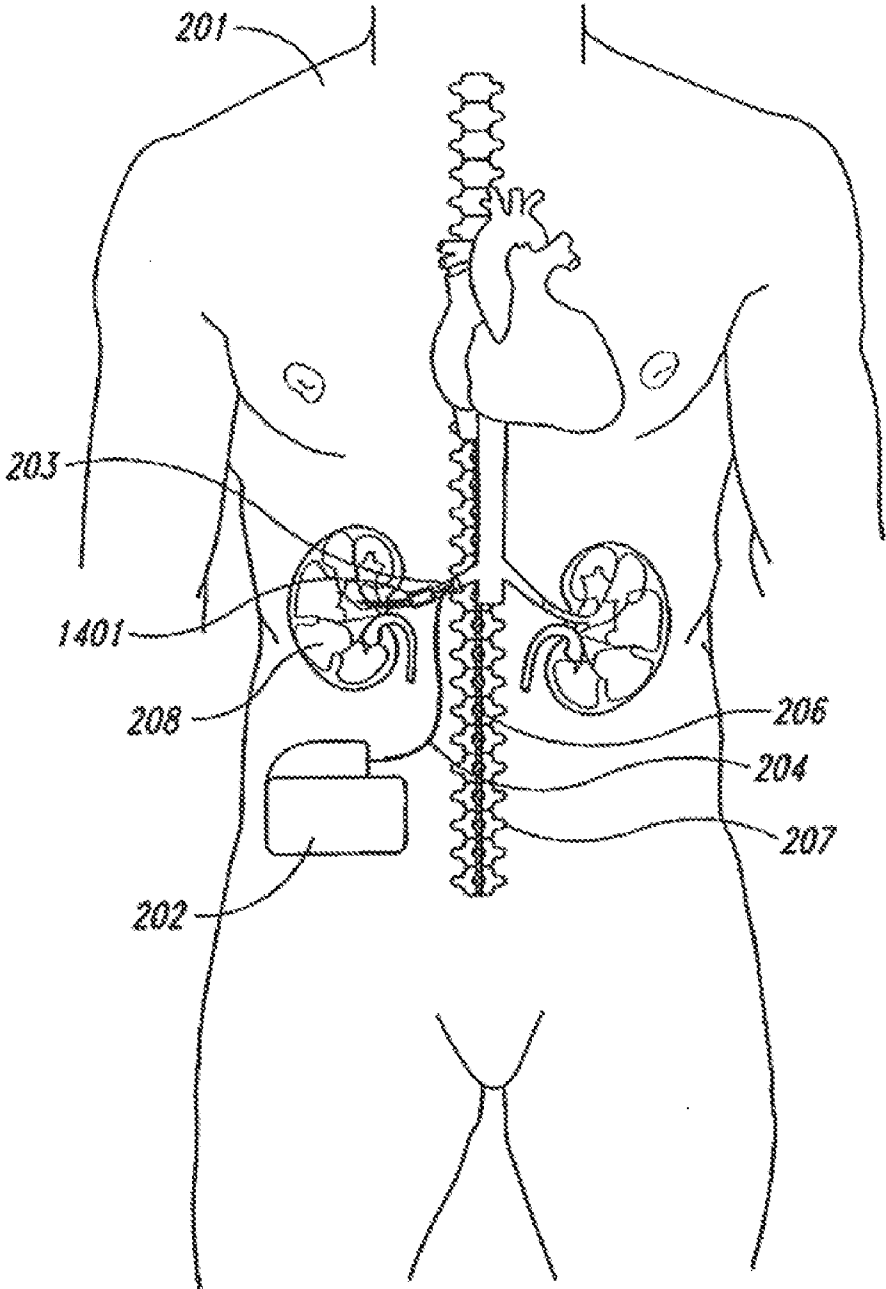

Fig. 14

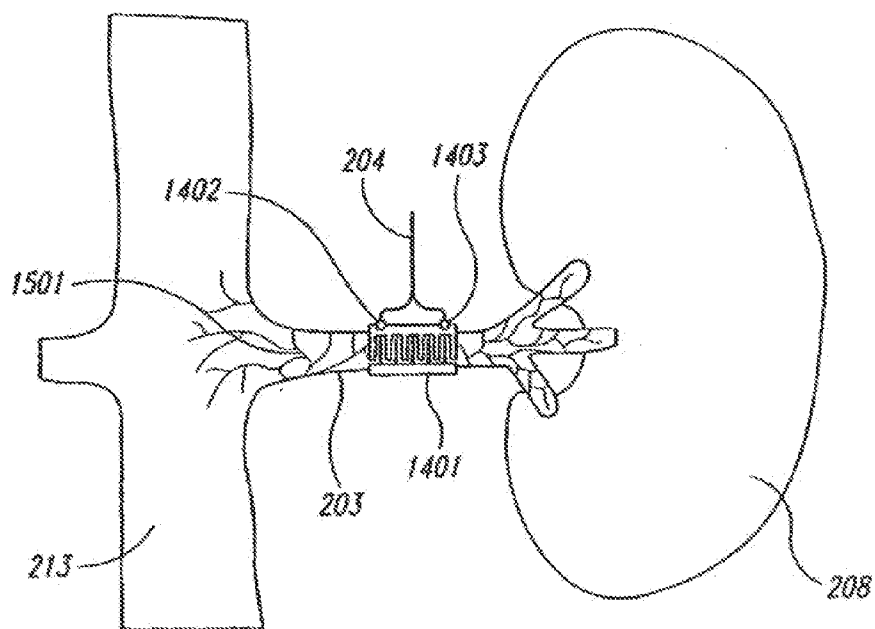

Fig. 15

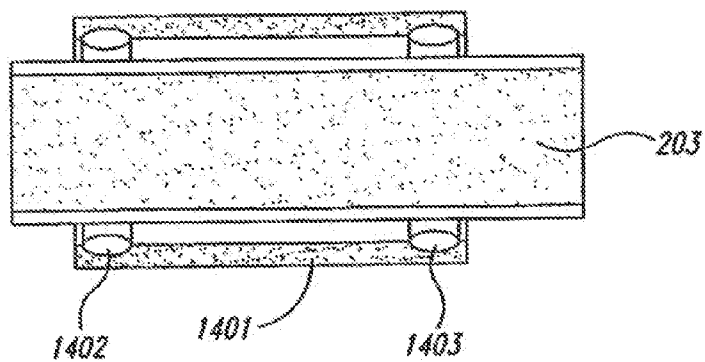

Fig. 16

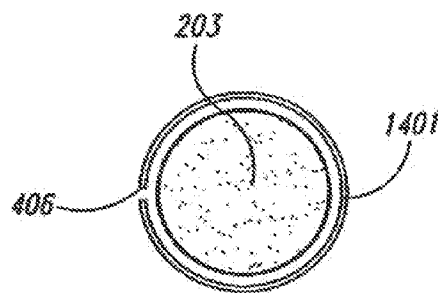

Fig. 17

RENAL NERVE STIMULATION METHOD FOR TREATMENT OF PATIENTS

RELATED APPLICATIONS

[0001] This application is related and claims priority to the following commonly-owned provisional application Ser. No. 60/370,190, entitled "Modulation Of Renal Nerve To Treat CHF", that was filed in the U.S. Patent and Trademark Office (USPTO) on Apr. 8, 2002; Ser. No. 60/415,575 entitled "Modulation Of Renal Nerve To Treat CHF", that was filed in the USPTO on Oct. 3, 2002, and Ser. No. 60/442,970 entitled "Treatment Of Renal Failure And Hypertension", that was filed in the USPTO on Jan. 29, 2003. The entirety of each of these provisional applications is incorporated by reference herein.

FIELD OF THE INVENTION

[0002] This invention relates to methods and apparatus for treatment of congestive heart failure, chronic renal failure and hypertension by nerve stimulation. In particular, the invention relates to the improvement of these conditions of patients by blocking signals to the renal (kidney) nerve.

BACKGROUND OF THE INVENTION

[0003] The Heart Failure Problem:

[0004] Congestive Heart Failure (CHF) is a form of heart disease still increasing in frequency. According to the American Heart Association, CHF is the "Disease of the Next Millennium". The number of patients with CHF is expected to grow even more significantly as an increasing number of the "Baby Boomers" reach 50 years of age. CHF is a condition that occurs when the heart becomes damaged and reduces blood flow to the organs of the body. If blood flow decreases sufficiently, kidney function becomes impaired and results in fluid retention, abnormal hormone secretions and increased constriction of blood vessels. These results increase the workload of the heart and further decrease the capacity of the heart to pump blood through the kidney and circulatory system. This reduced capacity further reduces blood flow to the kidney, which in turn further reduces the capacity of the blood. It is believed that the progressively-decreasing perfusion of the kidney is the principal non-cardiac cause perpetuating the downward spiral of the "Vicious Cycle of CHF". Moreover, the fluid overload and associated clinical symptoms resulting from these physiologic changes are predominant causes for excessive hospital admissions, terrible quality of life and overwhelming costs to the health care system due to CHF.

[0005] While many different diseases may initially damage the heart, once present, CHF is split into two types: Chronic CHF and Acute (or Decompensated-Chronic) CHF. Chronic Congestive Heart Failure is a longer term, slowly progressive, degenerative disease. Over years, chronic congestive heart failure leads to cardiac insufficiency. Chronic CHF is clinically categorized by the patient's ability to exercise or perform normal activities of daily living (such as defined by the New York Heart Association Functional Class). Chronic CHF patients are usually managed on an outpatient basis, typically with drugs.

[0006] Chronic CHF patients may experience an abrupt, severe deterioration in heart function, termed Acute Congestive Heart Failure, resulting in the inability of the heart to maintain sufficient blood flow and pressure to keep vital organs of the body alive. These acute CHF deteriorations can

occur when extra stress (such as an infection or excessive fluid overload) significantly increases the workload on the heart in a stable chronic CHF patient. In contrast to the step-wise downward progression of chronic CHF, a patient suffering acute CHF may deteriorate from even the earliest stages of CHF to severe hemodynamic collapse. In addition, Acute CHF can occur within hours or days following an Acute Myocardial Infarction (AMI), which is a sudden, irreversible injury to the heart muscle, commonly referred to as a heart attack.

[0007] Normal Kidney Function:

[0008] The kidneys are a pair of organs that lie in the back of the abdomen on each side of the vertebral column. Kidneys play an important regulatory role in maintaining the homeostatic balance of the body. The kidneys function like a complex chemical plant. The kidneys eliminate foreign chemicals from the body, regulate inorganic substances and the extracellular fluid, and function as endocrine glands, secreting hormonal substances like renin and erythropoietin.

[0009] The main functions of the kidney are to maintain the water balance of the body and control metabolic homeostasis. Healthy kidneys regulate the amount of fluid in the body by making the urine more or less concentrated, thus either reabsorbing or excreting more fluid, respectively. In case of renal disease, some normal and important physiological functions become detrimental to the patient's health. This process is called overcompensation. In the case of Chronic Renal Failure (CRF) patients overcompensation often manifests in hypertension (pathologically high blood pressure) that is damaging to heart and blood vessels and can result in a stroke or death.

[0010] The functions of the kidney can be summarized under three broad categories: a) filtering blood and excreting waste products generated by the body's metabolism; b) regulating salt, water, electrolyte and acid-base balance; and c) secreting hormones to maintain vital organ blood flow. Without properly functioning kidneys, a patient will suffer water retention, reduced urine flow and an accumulation of wastes toxins in the blood and body.

[0011] The primary functional unit of the kidneys that is involved in urine formation is called the "nephron". Each kidney consists of about one million nephrons. The nephron is made up of a glomerulus and its tubules, which can be separated into a number of sections: the proximal tubule, the medullary loop (loop of Henle), and the distal tubule. Each nephron is surrounded by different types of cells that have the ability to secrete several substances and hormones (such as renin and erythropoietin). Urine is formed as a result of a complex process starting with the filtration of plasma water from blood into the glomerulus. The walls of the glomerulus are freely permeable to water and small molecules but almost impermeable to proteins and large molecules. Thus, in a healthy kidney, the filtrate is virtually free of protein and has no cellular elements. The filtered fluid that eventually becomes urine flows through the tubules. The final chemical composition of the urine is determined by the secretion into and reabsorption of substances from the urine required to maintain homeostasis.

[0012] Receiving about 20% of cardiac output, the two kidneys filter about 125 ml of plasma water per minute. This is called the Glomerular Filtration Rate (GFR) and is the gold standard measurement of the kidney function. Since measurement of GFR is very cumbersome and expensive, clinically, the serum creatinine level or creatinine clearance are used as

surrogates to measure kidney function. Filtration occurs because of a pressure gradient across the glomerular membrane. The pressure in the arteries of the kidney pushes plasma water into the glomerulus causing filtration. To keep the GFR relatively constant, pressure in the glomerulus is held constant by the constriction or dilatation of the afferent and efferent arterioles, the muscular walled vessels leading to and from each glomerulus.

[0013] Abnormal Kidney Function in CHF:

[0014] The kidneys maintain the water balance of the body and control metabolic homeostasis. The kidneys regulate the amount of fluid in the body by making the urine more or less concentrated, thus either reabsorbing or excreting more fluid, respectively. Without properly functioning kidneys, a patient will suffer water retention, reduced urine flow and an accumulation of wastes toxins in the blood and body. These conditions resulting from reduced renal function or renal failure (kidney failure) are believed to increase the workload of the heart. In a CHF patient, renal failure will cause the heart to further deteriorate as the water build-up and blood toxins accumulate due to the poorly functioning kidneys and in turn, cause the heart further harm.

[0015] In a CHF patient, for any of the known cause of heart dysfunction, the heart will progressively fail and blood flow and pressure will drop in the patients circulatory system. In the acute heart failure, the short-term compensations serve to maintain perfusion to critical organs, notably the brain and the heart that cannot survive prolonged reduction in blood flow. In chronic heart failure, these same responses that initially aided survival in acute heart failure can become deleterious.

[0016] A combination of complex mechanisms contribute to the deleterious fluid overload in CHF. As the heart fails and blood pressure drops, the kidneys cannot function owing to insufficient blood pressure for perfusion and become impaired. This impairment in renal function ultimately leads to a decrease in urine output. Without sufficient urine output, the body retains fluids and the resulting fluid overload causes peripheral edema (swelling of the legs), shortness of breath (from fluid in the lungs), and fluid in the abdomen, among other undesirable conditions in the patient.

[0017] In addition, the decrease in cardiac output leads to reduced renal blood flow, increased neurohormonal stimulus, and release of the hormone renin from the juxtaglomerular apparatus of the kidney. This results in avid retention of sodium and thus volume expansion. Increased rennin results in the formation of angiotensin, a potent vasoconstrictor.

[0018] Heart failure and the resulting reduction in blood pressure reduces the blood flow and perfusion pressure through organs in the body, other than the kidneys. As they suffer reduced blood pressure, these organs may become hypoxic causing the development of a metabolic acidosis which reduces the effectiveness of pharmacological therapy as well as increases the risk of sudden death.

[0019] This spiral of deterioration that physicians observe in heart failure patients is believed to be mediated, in large part, by activation of a subtle interaction between heart function and kidney function, known as the renin-angiotensin system. Disturbances in the heart's pumping function results in decreased cardiac output and diminished blood flow. The kidneys respond to the diminished blood flow as though the total blood volume was decreased, when in fact the measured volume is normal or even increased. This leads to fluid reten-

tion by the kidneys and formation of edema causing fluid overload and increased stress on the heart.

[0020] Systemically, CHF is associated with an abnormally elevated peripheral vascular resistance and is dominated by alterations of the circulation resulting from an intense disturbance of sympathetic nervous system function. Increased activity of the sympathetic nervous system promotes a downward vicious cycle of increased arterial vasoconstriction (increased resistance of vessels to blood flow) followed by a further reduction of cardiac output, causing even more diminished blood flow to the vital organs.

[0021] In CHF via the previously explained mechanism of vasoconstriction, the heart and circulatory system dramatically reduces blood flow to kidneys. During CHF, the kidneys receive a command from higher neural centers via neural pathways and hormonal messengers to retain fluid and sodium in the body. In response, to stress on the heart, the neural centers command the kidneys to reduce their filtering functions. While in the short term, these commands can be beneficial, if these commands continue over hours and days they can jeopardize the persons life or make the person dependent on artificial kidney for life by causing the kidneys to cease functioning.

[0022] When the kidneys do not fully filter the blood, a huge amount of fluid is retained in the body resulting in bloating (fluid in tissues), and increases the workload of the heart. Fluid can penetrate into the lungs and the patient becomes short of breath. This odd and self-destructive phenomenon is most likely explained by the effects of normal compensatory mechanisms of the body that improperly perceive the chronically low blood pressure of CHF as a sign of temporary disturbance such as bleeding.

[0023] In an acute situation, the organism tries to protect its most vital organs, the brain and the heart, from the hazards of oxygen deprivation. Commands are issued via neural and hormonal pathways and messengers. These commands are directed toward the goal of maintaining blood pressure to the brain and heart, which are treated by the body as the most vital organs. The brain and heart cannot sustain low perfusion for any substantial period of time. A stroke or a cardiac arrest will result if the blood pressure to these organs is reduced to unacceptable levels. Other organs, such as kidneys, can withstand somewhat longer periods of ischemia without suffering long-term damage. Accordingly, the body sacrifices blood supply to these other organs in favor of the brain and the heart.

[0024] The hemodynamic impairment resulting from CHF activates several neurohormonal systems, such as the renin-angiotensin and aldosterone system, sympatho-adrenal system and vasopressin release. As the kidneys suffer from increased renal vasoconstriction, the filtering rate (GFR) of the blood drops and the sodium load in the circulatory system increases. Simultaneously, more renin is liberated from the juxtaglomerular of the kidney. The combined effects of reduced kidney functioning include reduced glomerular sodium load, an aldosterone-mediated increase in tubular reabsorption of sodium, and retention in the body of sodium and water. These effects lead to several signs and symptoms of the CHF condition, including an enlarged heart, increased systolic wall stress, an increased myocardial oxygen demand, and the formation of edema on the basis of fluid and sodium retention in the kidney. Accordingly, sustained reduction in renal blood flow and vasoconstriction is directly responsible for causing the fluid retention associated with CHF.

[0025] In view of the physiologic mechanisms described above it is positively established that the abnormal activity of the kidney is a principal non-cardiac cause of a progressive condition in a patient suffering from CHF.

[0026] Growing population of late stage CHF patients is an increasing concern for the society. The disease is progressive, and as of now, not curable. The limitations of drug therapy and its inability to reverse or even arrest the deterioration of CHF patients are clear. Surgical therapies are effective in some cases, but limited to the end-stage patient population because of the associated risk and cost. There is clearly a need for a new treatment that will overcome limitations of drug therapy but will be less invasive and costly than heart transplantation.

[0027] Similar condition existed several decades ago in the area of cardiac arrhythmias. Limitations of anti-arrhythmic drugs were overcome by the invention of heart pacemakers. Widespread use of implantable electric pacemakers resulted in prolonged productive life for millions of cardiac patients. So far, all medical devices proposed for the treatment of CHF are cardio-centric i.e., focus on the improvement of the heart function. The dramatic role played by kidneys in the deterioration of CHF patients has been overlooked by the medical device industry.

[0028] Neural Control of Kidneys:

[0029] The autonomic nervous system is recognized as an important pathway for control signals that are responsible for the regulation of body functions critical for maintaining vascular fluid balance and blood pressure. The autonomic nervous system conducts information in the form of signals from the body's biologic sensors such as baroreceptors (responding to pressure and volume of blood) and chemoreceptors (responding to chemical composition of blood) to the central nervous system via its sensory fibers. It also conducts command signals from the central nervous system that control the various innervated components of the vascular system via its motor fibers.

[0030] Experience with human kidney transplantation provided early evidence of the role of the nervous system in the kidney function. It was noted that after the transplant, when all the kidney nerves are totally severed, the kidney increased the excretion of water and sodium. This phenomenon was also observed in animals when the renal nerves were cut or chemically destroyed. The phenomenon was called "denervation diuresis" since the denervation acted on a kidney similar to a diuretic medication. Later the "denervation diuresis" was found to be associated with the vasodilatation the renal arterial system that led to the increase of the blood flow through the kidney. This observation was confirmed by the observation in animals that reducing blood pressure supplying the kidney could reverse the "denervation diuresis".

[0031] It was also observed that after several months passed after the transplant surgery in successful cases, the "denervation diuresis" in transplant recipients stopped and the kidney function returned to normal. Originally it was believed that the "renal diuresis" is a transient phenomenon and that the nerves conducting signals from the central nervous system to the kidney are not essential for the kidney function. Later, new discoveries led to the different explanation. It is believed now that the renal nerves have a profound ability to regenerate and the reversal of the "denervation diuresis" shall be attributed to the growth of the new nerve fibers supplying kidneys with the necessary stimuli.

[0032] Another body of research that is of particular importance for this application was conducted in the period of 1964-1969 and focused on the role of the neural control of secretion of the hormone renin by the kidney. As was discussed previously, renin is a hormone responsible for the "vicious cycle" of vasoconstriction and water and sodium retention in heart failure patients. It was demonstrated that increase (renal nerve stimulation) or decrease (renal nerve denervation) in renal sympathetic nerve activity produced parallel increases and decreases in the renin secretion rate by the kidney, respectively.

[0033] In summary, it is known from clinical experience and the large body of animal research that the stimulation of the renal nerve leads to the vasoconstriction of blood vessels supplying the kidney, decreased renal blood flow, decreased removal of water and sodium from the body and increased renin secretion. These observations closely resemble the physiologic landscape of the deleterious effects of the chronic congestive heart failure. It is also known that the reduction of the sympathetic renal nerve activity, achieved by denervation, can reverse these processes.

[0034] It was established in animal models that the heart failure condition results in the abnormally high sympathetic stimulation of the kidney. This phenomenon was traced back to the sensory nerves conducting signals from baroreceptors to the central nervous system. Baroreceptors are the biologic sensors sensitive to blood pressure. They are present in the different locations of the vascular system. Powerful relationship exists between the baroreceptors in the carotid arteries (supplying brain with arterial blood) and the sympathetic nervous stimulus to the kidneys. When the arterial blood pressure was suddenly reduced in experimental animals with heart failure, the sympathetic tone increased. Nevertheless the normal baroreflex alone, cannot be responsible for the elevated renal nerve activity in chronic CHF patients. If exposed to the reduced level of arterial pressure for a prolonged time baroreceptors normally "reset" i.e. return to the baseline level of activity until a new disturbance is introduced. Therefore, in chronic CHF patients the components of the autonomic nervous system responsible for the control of blood pressure and the neural control of the kidney function become abnormal. The exact mechanisms that cause this abnormality are not fully understood but, its effects on the overall condition of the CHF patients are profoundly negative.

[0035] End Stage Renal Disease Problem:

[0036] There is a dramatic increase in patients with end-stage renal disease (ESRD) due to diabetic nephropathy, chronic glomerulonephritis and uncontrolled hypertension. In the US alone, 372,000 patients required dialysis in the year 2000. There were 90,000 new cases of ESRD in 1999 with the number of patients on dialysis is expected to rise to 650,000 by the year 2010. The trends in Europe and Japan are forecasted to follow a similar path. Mortality in patients with ESRD remains 10-20 times higher than that in the general population. Annual Medicare patient costs \$52,868 for dialysis and \$18,496 for transplantation. The total cost for Medicare patients with ESRD in 1998 was \$12.04 billion.

[0037] The primary cause of these problems is the slow relentless progression of Chronic Renal Failure (CRF) to ESRD. CRF represents a critical period in the evolution of ESRD. The signs and symptoms of CRF are initially minor, but over the course of 2-5 years, become progressive and irreversible. Until the 1980's, there were no therapies that

could significantly slow the progression of CRF to ESRD. While some progress has been made in combating the progression to and complications of ESRD in last two decades, the clinical benefits of existing interventions remain limited with no new drug or device therapies on the horizon.

[0038] Progression of Chronic Renal Failure:

[0039] It has been known for several decades that renal diseases of diverse etiology (hypotension, infection, trauma, autoimmune disease, etc.) can lead to the syndrome of CRF characterized by systemic hypertension, proteinuria (excess protein filtered from the blood into the urine) and a progressive decline in GFR ultimately resulting in ESRD. These observations suggested that CRF progresses via a common pathway of mechanisms, and that therapeutic interventions inhibiting this common pathway may be successful in slowing the rate of progression of CRF irrespective of the initiating cause.

[0040] To start the vicious cycle of CRF, an initial insult to the kidney causes loss of some nephrons. To maintain normal GFR, there is an activation of compensatory renal and systemic mechanisms resulting in a state of hyperfiltration in the remaining nephrons. Eventually, however, the increasing numbers of nephrons "overworked" and damaged by hyperfiltration are lost. At some point, a sufficient number of nephrons are lost so that normal GFR can no longer be maintained. These pathologic changes of CRF produce worsening systemic hypertension, thus high glomerular pressure and increased hyperfiltration. Increased glomerular hyperfiltration and permeability in CRF pushes an increased amount of protein from the blood, across the glomerulus and into the renal tubules. This protein is directly toxic to the tubules and leads to further loss of nephrons, increasing the rate of progression of CRF. This vicious cycle of CRF continues as the GFR drops, with loss of additional nephrons leading to further hyperfiltration and eventually to ESRD requiring dialysis. Clinically, hypertension and excess protein filtration have been shown to be two major determining factors in the rate of progression of CRF to ESRD.

[0041] Though previously clinically known, it was not until the 1980s that the physiologic link between hypertension, proteinuria, nephron loss and CRF was identified. In 1990s the role of sympathetic nervous system activity was elucidated. Afferent signals arising from the damaged kidneys due to the activation of mechanoreceptors and chemoreceptors stimulate areas of the brain responsible for blood pressure control. In response brain increases sympathetic stimulation on the systemic level resulting in the increased blood pressure primarily through vasoconstriction of blood vessels.

[0042] When elevated sympathetic stimulation reaches the kidney via the efferent sympathetic nerve fibers, it produces major deleterious effects in two forms:

[0043] A. Kidney is damaged by direct renal toxicity from the release of sympathetic neurotransmitters (such as norepinephrine) in the kidney independent of the hypertension.

[0044] B. Secretion of renin that activates Angiotensin II is increased leading to the increased systemic vasoconstriction and exacerbated hypertension.

[0045] Over time damage to the kidney leads to further increase of afferent sympathetic signals from the kidney to the brain. Elevated Angiotensin II further facilitates internal renal release of neurotransmitters. The feedback loop is therefore closed accelerating the deterioration of the kidney.

BRIEF DESCRIPTION OF THE INVENTION

[0046] A treatment of heart failure, renal failure and hypertension has been developed to arrest or slow down the pro-

gression of the disease. This treatment is expected to delay the morbid conditions and death often suffered by CHF patients and to delay the need for dialysis in renal failure. This treatment is expected to control hypertension in patients that do not respond to drugs or require multiple drugs.

[0047] The treatment includes a device and method that reduces the abnormally elevated sympathetic nerve signals that contribute to the progression of heart and renal disease. The desired treatment should be implemented while preserving a patient's mobility and quality of life without the risk of major surgery.

[0048] The treatment breaks with tradition and proposes a counterintuitive novel method and apparatus of treating heart failure, renal failure and hypertension by electrically or chemically modulating the nerves of the kidney. Elevated nerve signals to and from the kidney are a common pathway of the progression of these chronic conditions.

[0049] Chronic heart and renal failure is treated by reducing the sympathetic efferent or afferent nerve activity of the kidney. Efferent nerves (as opposed to afferent) are the nerves leading from the central nervous system to the organ, in this case to the kidney. Sympathetic nervous system (as opposed to parasympathetic) is the part of the autonomic nervous system that is concerned especially with preparing the body to react to situations of stress or emergency that tends to depress secretion, decrease the tone and contractility of smooth muscle, and increase heart rate. In the case of renal sympathetic activity, it is manifested in the inhibition of the production of urine and excretion of sodium. It also elevates the secretion of renin that triggers vasoconstriction. This mechanism is best illustrated by the response of the body to severe bleeding. When in experimental animals, the blood pressure is artificially reduced by bleeding, and the sympathetic inhibition of the kidney is increased to maintain blood pressure with an ultimate goal of preserving the brain from hypotension. The resulting vasoconstriction and fluid retention work in synchrony to help the body to maintain homeostasis.

[0050] Efferent renal nerve activity is considered postganglionic, autonomic and exclusively sympathetic. In general, efferent sympathetic nerves can cause a variety of responses in the innervated organs. Studies of sympathetic renal nerves show that they have a strong tendency to behave as a uniform population that acts as vasoconstrictors. The renal postganglionic neurons are modulated by preganglionic (ganglion is a "knot" or agglomeration of nerve cells) nerves that originate from the brain and thoracic and upper lumbar regions of the spinal cord.

[0051] The preganglionic nerves have diverse function and are likely to have high degree of redundancy. Although different pathways exist to achieve reduced efferent renal nerve activity, the simplest way is to denervate the postganglionic nerves with an electric stimulus or a chemical agent. The same desired affect could be achieved by total surgical, electric or chemical destruction (ablation) of the nerve. For two reasons this is not a preferred pathway. As was described before, renal nerves regenerate and can grow back as soon as several months after surgery. Secondly, total irreversible denervation of the kidney can result in danger to the patient. Overdiuresis or removal of excess water from blood can result in the reduction of blood volume beyond the amount that can be rapidly replaced by fluid intake. This can result in hypovolemia and hypotension. Hypotension is especially dangerous in heart failure patients with the reduced capacity of the

heart to pump blood and maintain blood pressure. In addition, the vasodilation of the renal artery resulting from the renal denervation will cause a significant increase in renal blood flow. In a healthy person, renal blood flow can amount to as much as 20% of the total cardiac output. In heart failure patients cardiac output is reduced and the renal denervation can "steal" even larger fraction of it from circulation. This, in turn, can lead to hypotension. Also, in a heart failure patient the heart has limited ability to keep up with the demand for oxygenated blood that can be caused by even modest physical effort. Therefore a heart failure patient that can sustain the increased blood flow to the kidneys while at rest can face serious complications resulting from acute hypotension, if the demand for blood flow is increased by temperature change or exercise.

[0052] In view of the factors described above it is desired to have means to reduce the efferent sympathetic stimulation of the kidney in CHF patients in a reversible, controlled fashion preferably based on a physiologic feedback signal that is indicative of the oxygen demand by the body, blood pressure, cardiac output of the patient or a combination of these and other physiologic parameters.

[0053] The treatment also breaks with tradition and proposes a counterintuitive novel method and apparatus of treating chronic renal failure (CRF) with the goal of slowing down the progression of CRF to the ESRD by electrically or chemically altering the sympathetic neural stimulation entering and exiting the kidney. The described method and apparatus can be also used to treat hypertension in patients with renal disease or abnormal renal function.

[0054] To control the afferent nerve signals from the kidney to the brain and block efferent nerve stimuli from entering the kidney (without systemic side effects of drug therapy), a renal nerve stimulator is implanted and attached to an electrode lead placed around or close to the renal artery. Stimulation effectively blocks or significantly reduces both efferent and afferent signals traveling between the kidney, the autonomic nervous system and the central nervous system.

[0055] The benefits that may be possible by controlling renal nerve signals to reduce efferent overstimulation are:

[0056] a. The secretion of renin by kidney should be reduced by 40-50% translating into the proportionate reduction of systemic angiotensin II, resulting in the reduction of blood pressure in all hypertensive patients including patients refractory to drugs.

[0057] b. Similar to renoprotective mechanisms of ACE-I, the reduction of angiotensin II should result in slowed progression of intrarenal changes in glomerular structure and function independent of blood pressure control.

[0058] c. Similar to the effects of moxonidine, reduced efferent overstimulation should reduce damage by direct renal toxicity from the release of sympathetic neurotransmitters.

[0059] Following the reduction of the afferent sympathetic renal feedback to the brain, there is expected to be a marked reduction in the systemic efferent overstimulation. This will translate into the systemic vasodilation and reduction of hypertension independent of the renin-angiotensin II mechanism.

[0060] Renal nerve stimulation in hypertensive CRF patients is unlikely to cause clinically relevant episodes of hypotension. Systemic blood pressure is tightly controlled by feedbacks from baroreceptors in aorta and carotid sinuses. These mechanisms are likely to take over if the blood pressure

becomes too low. In polycystic kidney disease (PKD) patients who underwent surgery for total denervation of kidneys, denervation resolved hypertension without postoperative episodes of hypotension.

[0061] Technique for Nerve Modulation

[0062] Nerve activity can be reversibly modulated in several different ways. Nerves can be stimulated with electric current or chemicals that enhance or inhibit neurotransmission. In the case of electrical stimulation, a stimulator containing a power source is typically connected to the nerve by wires or leads. Leads can terminate in electrodes, cuffs that enclose the nerve or in conductive anchors (screws or hooks) that are embedded in tissue. In the later case, the lead is designed to generate sufficient electric field to alter or induce current in the nerve without physically contacting it. The electrodes or leads can be bipolar or unipolar. There are permanent leads that are implanted for months and years to treat a chronic condition and temporary leads used to support the patient during an acute stage of the disease. The engineering aspects of design and manufacturing of nerve stimulators, pacemakers, leads, anchors and nerve cuffs are well known.

[0063] Proposed clinical applications of nerve stimulation include: Depression, Anxiety, Alzheimer's Disease, Obesity, and others. In all existing clinical applications except pain control, the targeted nerves are stimulated to increase the intensity of the transmitted signal. To achieve relief of hypertension and CRF signal traffic traveling to and from the kidney via renal nerves needs to be reduced. This can be achieved by known methods previously used in physiologic studies on animals. A nerve can be paced with electric pulses at high rate or at voltage that substantially exceed normal traffic. As a result, a nerve will be "overpaced", run out of neurotransmitter substance and transmit less stimulus to the kidney. Alternatively relatively high voltage potential can be applied to the nerve to create a blockade. This method is known as "voltage clamping" of a nerve. Infusion of a small dose of a local anesthetic in the vicinity of the nerve will produce the same effect.

[0064] Ablation of conductive tissue pathways is another commonly used technique to control arterial or ventricular tachycardia of the heart. Ablation can be performed by introduction of a catheter into the venous system in close proximity of the sympathetic renal nerve subsequent ablation of the tissue. Catheter based ablation devices were previously used to stop electric stimulation of nerves by heating nerve tissue with RF energy that can be delivered by a system of electrodes. RF energy thus delivered stops the nerve conduction. U.S. Pat. No. 6,292,695 describes in detail a method and apparatus for transvascular treatment of tachycardia and fibrillation with nerve stimulation and ablation. Similar catheter based apparatus can be used to ablate the renal nerve with an intent to treat CRF. The method described in this invention is applicable to irreversible ablation of the renal nerve by electric energy, cold, or chemical agents such as phenol or alcohol.

[0065] Thermal means may be used to cool the renal nerve and adjacent tissue to reduce the sympathetic nerve stimulation of the kidney. Specifically, the renal nerve signals may be dampened by either directly cooling the renal nerve or the kidney, to reduce their sensitivity, metabolic activity and function, or by cooling the surrounding tissue. An example of this approach is to use the cooling effect of the Peltier device. Specifically, the thermal transfer junction may be positioned adjacent the vascular wall or a renal artery to provide a cool-

ing effect. The cooling effect may be used to dampen signals generated by the kidney. Another example of this approach is to use the fluid delivery device to deliver a cool or cold fluid (e.g. saline).

BRIEF DESCRIPTION OF THE DRAWINGS

[0066] A preferred embodiment and best mode of the invention is illustrated in the attached drawings that are described as follows:

[0067] FIG. 1 illustrates the role of sympathetic renal nerve stimulation in congestive heart failure (CHF).

[0068] FIG. 2 illustrates the preferred implanted electro-stimulation embodiment of the present invention.

[0069] FIG. 3 illustrates stimulation of renal nerves across the wall of the renal vein.

[0070] FIG. 4 illustrates the drug infusion blocking embodiment with an implanted drug pump.

[0071] FIG. 5 illustrates the arterial pressure based control algorithm for renal nerve modulation.

[0072] FIG. 6 illustrates electrostimulation of the renal nerve with an anodal block.

[0073] FIG. 7 illustrates different nerve fibers in a nerve bundle trunk.

[0074] FIG. 8 illustrates renal nerve modulation by blocking electric signals at one point and stimulating the nerve at a different point.

[0075] FIG. 9 illustrates transvenous stimulation of the renal nerve with electric field.

[0076] FIG. 10 illustrates an embodiment where the stimulation lead is placed using laparoscopic surgery.

[0077] FIG. 11 illustrates a patient controlled stimulation embodiment.

[0078] FIG. 12 illustrates the progression of CRF to ESRD.

[0079] FIG. 13 illustrates the physiologic mechanisms of CRF.

[0080] FIG. 14 illustrates stimulation of renal nerves in a patient with an implanted stimulator with a renal artery cuff electrode.

[0081] FIG. 15 illustrates the placement of a stimulation cuff on a renal artery end nerve plexus.

[0082] FIG. 16 illustrates the design of the cuff electrode that wraps around an artery.

[0083] FIG. 17 illustrates the interface between cuff electrodes and the renal artery surface.

DETAILED DESCRIPTION OF THE INVENTION

[0084] A method and apparatus has been developed to regulate sympathetic nerve activity to the kidney to improve a patient's renal function and overall condition, and ultimately to arrest or reverse the vicious cycle of CHF disease.

[0085] FIG. 1 illustrates the role of sympathetic renal nerves in heart failure. Neural pathways are indicated by solid lines, hormones by interrupted lines. Baroreceptors 101 respond to low blood pressure resulting from the reduced ability of the failing heart 103 to pump blood. Unloading of baroreceptors 101 in the left ventricle of the heart 103, carotid sinus, and aortic arch (not shown) generates afferent neural signals 113 that stimulate cardio-regulatory centers in the brain 102. This stimulation results in activation of efferent pathways in the sympathetic nervous system 118. Sympathetic signals are transmitted to the spinal cord 106, sympathetic ganglia 107 and via the sympathetic efferent renal nerve 109 to the kidney 111. The increased activity of sym-

pathetic nerves 108 also causes vasoconstriction 110 (increased resistance) of peripheral blood vessels.

[0086] In the kidney 111 efferent sympathetic nerve stimulation 109 causes retention of water (reduction of the amount of urine) and retention of sodium 112 an osmotic agent that is responsible for the expansion of blood volume. The sympathetic stimulation of the kidney stimulates the release of hormones renin 105 and angiotensin II. These hormones activate the complex renin-angiotensin-aldosterone system 117 leading to more deleterious hormones causing vasoconstriction 104 and heart damage 116. The sympathetic stimulation of the hypothalamus of the brain 102 results in the release of the powerful hormone vasopressin 114 that causes further vasoconstriction of blood vessels. Angiotensin II constricts blood vessels and stimulates the release of aldosterone from adrenal gland (not shown). It also increases tubular sodium reabsorption (sodium retention) in the kidney 111 and causes remodeling of cardiac myocytes therefore contributing to the further deterioration of the heart 103 and the kidney 111.

[0087] It can be inferred from the FIG. 1 that the renal efferent sympathetic stimulation in heart failure is caused by low blood pressure and is a primary factor responsible for the most debilitating symptom of heart failure i.e. fluid overload. It also contributes to the progression of the disease. Acting through the volume overload and peripheral vasoconstriction (together increasing load on the heart) it accelerates the enlargement of the left ventricle that in turn results in the deteriorating ability of the heart to pump blood. Drugs used to treat heart failure address these issues separately. Diuretics are used to reduce fluid overload by reducing the reabsorption of sodium and increasing the excretion of water 112. Vasodilators are used to reduce peripheral vasoconstriction 110 by reducing levels of angiotensin 117. Inotropic agents are used to increase blood pressure and de-activate the signals from baroreceptors 101. These drugs have limited affect and ultimately fail to control the progression and debilitating symptoms heart failure. The proposed invention corrects the neuro-hormonal misbalance in heart failure by directly controlling the sympathetic neural stimulation 109 of the kidney 111.

[0088] FIG. 2 shows a patient 201 suffering from chronic congestive heart failure treated in accordance with the invention. An implantable device 202 is implanted in the patients body. An implantable device can be an electric device similar to a pacemaker or nerve stimulator or a chemical substance infusion device. Such devices are well known in the field of medicine. Internal mechanism of the implantable device typically includes a battery 203, an electronic circuit and (in the case of a drug delivery device) a reservoir with medication.

[0089] An example of an implantable drug infusion device is the MiniMed 2007™ implantable insulin pump system for treatment of diabetes or the SynchroMed Infusion System used to control chronic pain, both manufactured by Medtronic Inc. The drug used in this embodiment can be a common local anesthetic such as Novocain or Lidocaine or a more long lasting equivalent anesthetic. Alternatively, a nerve toxin such as the botox can be used to block the nerve. An example of an implantable nerve stimulator is the Vagus Nerve Stimulation (VNS™) with the Cyberonics NeuroCybernetic Prosthesis (NCP®) System used for treatment of epilepsy. It is manufactured by Cyberonics Inc. The internal mechanism of the implantable device typically includes a battery, an electronic circuit and (in the case of a drug delivery device), a reservoir with medication. Neurostimulation systems from different manufacturers are virtually identical

across application areas, usually varying only in the patterns of stimulating voltage pulses, style or number of electrodes used, and the programmed parameters. The basic implantable system consists of a pacemaker-like titanium case enclosing the power source and microcircuitry that are used to create and regulate the electrical impulses. An extension lead attached to this generator carries the electrical pulses to the electrode lead that is implanted or attached to the nerves or tissues to be stimulated.

[0090] The implantable device **202** is equipped with the lead **204** connecting it to the renal nerve **205**. The lead can contain an electric wire system or a catheter for delivery of medication or both. Renal nerve conducts efferent sympathetic stimulation from the sympathetic trunk **206** to the kidney **208**. Sympathetic trunk is connected to the patient's spinal cord inside the spine **207**. The connection can be located between the kidney **208** and the posterior renal or other renal ganglia (not shown) in the region of the 10th, 11th and 12th thoracic and 1st lumbar segments of the spine **207**.

[0091] The implantable device **202** is also equipped with the sensor lead **209** terminated with the sensor **210**. The sensor can be a pressure sensor or an oxygen saturation sensor. The sensor **210** can be located in the left ventricle of the heart **211**, right atrium of the heart or other cavity of the heart. It can also be located outside of the heart in the aorta **213**, the aortic arch **212** or a carotid artery **214**. If the sensor is a pressure sensor, it is used to supply the device **202** with the information necessary to safely regulate the sympathetic nerve signals to the kidney **208**. A venous blood oxygen saturation signal can be used in a similar way to control the sympathetic nerve traffic based on oxygen demand. The sensor will be placed in the right atrium of the heart or in the vena cava. More than one sensor can be used in combination to supply information to the device. Sensors can be inside the vascular system (blood vessels) or outside of it. For example, a motion sensor can be used to detect activity of the person. Such sensor does not require placement outside the implanted device case and can be integrated inside the sealed case of the device **202** as a part of the internal mechanism.

[0092] FIG. 3 shows external renal nerve stimulator apparatus **306** connected to the electrode tip **308** by the catheter **301**. A catheter is inserted via an insertion site **303** into the femoral vein **305** into the vena cava **302** and further into the renal vein **304**. The tip **308** is then brought into the electric contact with the wall of the vein **304**. Hooks or screws, similar to ones used to secure pacemaker leads, can be used to anchor the tip and improve the electric contact. The tip **308** can have one, two or more electrodes integrated in its design. The purpose of the electrodes is to generate the electric field sufficiently strong to influence traffic along the renal nerve **205** stimulating the kidney **208**.

[0093] Two potential uses for the embodiment shown on FIG. 3 are the acute short-term stimulation of the renal nerve and the implanted embodiment. For short term treatment, a catheter equipped with electrodes on the tip is positioned in the renal vein. The proximal end of the catheter is left outside of the body and connected to the electro stimulation apparatus. For the implanted application, the catheter is used to position a stimulation lead, which is anchored in the vessel and left in place after the catheter is withdrawn. The lead is then connected to the implantable stimulator that is left in the body and the surgical site is closed. Patients have the benefit of mobility and lower risk of infection with the implanted stimulator-lead system.

[0094] Similar to the venous embodiment, an arterial system can be used. Catheter will be introduced via the femoral artery and aorta (not shown) into the renal artery **307**. Arterial catheterization is more dangerous than venous but may achieve superior result by placing stimulation electrode (or electrodes) in close proximity to the renal nerve without surgery.

[0095] FIG. 4 shows the use of a drug infusion pump **401** to block or partially block stimulation of the kidney **208** by infiltrating tissue proximal to the renal nerve **205** with a nerve-blocking drug. Pump **401** can be an implanted drug pump. The pump is equipped with a reservoir **403** and an access port (not shown) to refill the reservoir with the drug by puncturing the skin of the patient and the port septum with an infusion needle. The pump is connected to the infusion catheter **402** that is surgically implanted in the proximity of the renal nerve **205**. The drug used in this embodiment can be a common local anesthetic such as Novocain. If it is desired to block the nerve for a long time after a single bolus drug infusion, a nerve toxin such as botox (botulism toxin) can be used as a nerve-blocking drug. Other suitable nerve desensitizing agents may comprise, for example, tetrodotoxin or other inhibitor of excitable tissues.

[0096] FIG. 5 illustrates the use of arterial blood pressure monitoring to modulate the treatment of CHF with renal nerve blocking. The blood pressure is monitored by the computer controlled implanted device **202** (FIG. 2) using the implanted sensor **210**. Alternatively the controlling device can be incorporated in the external nerve stimulator **306** (FIG. 3) and connected to a standard blood pressure measurement device (not shown). The objective of control is to avoid hypotension that can be caused by excessive vasodilation of renal arteries caused by suppression of renal sympathetic stimulus. This may cause the increase of renal blood flow dangerous for the heart failure patient with the limited heart pumping ability. The control algorithm increases or decreases the level of therapy with the goal of maintaining the blood pressure within the safe range. Similarly the oxygen content of venous or arterial blood can be measured and used to control therapy. Reduction of blood oxygen is an indicator of insufficient cardiac output in heart failure patients.

[0097] FIG. 6 illustrates the principles of modulating renal nerve signal with an anodal block. Renal nerve **601** conducts efferent sympathetic electric signals in the direction towards the kidney **602**. Renal nerve **601** trunk is enveloped with two conductive cuff type electrodes: the anode **603** is a positive pole and the cathode **604** is a negative pole electrode. It is significant that the anode **603** is downstream of the cathode and closer to the kidney while the cathode is upstream of the anode and closer to the spine where the sympathetic nerve traffic is coming from. The electric current flowing between the electrodes opposes the normal propagation of nerve signals and creates a nerve block. Anode **603** and cathode **604** electrodes are connected to the signal generator (stimulator) **306** with wires **606**. This embodiment has a practical application even if the device for renal nerve signal modulation is implanted surgically. During surgery the renal nerve is exposed and cuffs are placed that overlap the nerve. The wires and the stimulator can be fully implanted at the time of surgery. Alternatively wires or leads can cross the skin and connect to the signal generator outside of the body. An implantable stimulator can be implanted later during a separate surgery or the use of an external stimulator can be continued.

[0098] Clinically used spiral cuffs for connecting to a nerve are manufactured by Cyberonics Inc. (Houston, Tex.) that also manufactures a fully implantable nerve stimulator operating on batteries. See also, e.g., U.S. Pat. No. 5,251,643. Various external signal generators suitable for nerve stimulation are available from Grass-Telefactor Astro-Med Product Group (West Warwick, R.I.). Nerve cuff electrodes are well known. See, e.g., U.S. Pat. No. 6,366,815. The principle of the anodal block is based on the observation that close to an anodal electrode contact the propagation of a nerve action potential can be blocked due to hyperpolarization of the fiber membrane. See e.g., U.S. Pat. Nos. 5,814,079 and 5,800,464. If the membrane is sufficiently hyperpolarized, action potentials cannot pass the hyperpolarized zone and are annihilated.

[0099] As large diameter fibers need a smaller stimulus for their blocking than do small diameter fibers, a selective blockade of the large fibers is possible. See e.g., U.S. Pat. No. 5,755,750. The activity in different fibers of a nerve in an animal can be selectively blocked by applying direct electric current between an anode and a cathode attached to the nerve.

[0100] Antidromic pulse generating wave form for collision blocking is an alternative means of inducing a temporary electric blockade of signals traveling along nerve fibers. See e.g., U.S. Pat. No. 4,608,985. In general, nerve traffic manipulation techniques such as anodal blocking, cathodal blocking and collision blocking are sufficiently well described in scientific literature and are available to an expert in neurology. Most of blocking methods allow sufficient selectivity and reversibility so that the nerve will not be damaged in the process of blocking and that selective and gradual modulation or suppression of traffic in different functional fibers can be achieved.

[0101] A nerve is composed of the axons of a large number of individual nerve fibers. A large nerve, such as a renal nerve, may contain thousands of individual nerve fibers, both myelinated and non-myelinated. Practical implementation of physiological blockade of selective nerve fibers in a living organism is illustrated by the paper "Respiratory responses to selective blockade of carotid sinus baroreceptors in the dog" by Francis Hopp. Both anodal block and local anesthesia by injection of bupivacaine (a common long-acting local anaesthetic, used for surgical anaesthesia and acute pain management) were applied to the surgically isolated and exposed but intact nerve leading from baroreceptors (physiologic pressure sensors) in the carotid sinus of the heart to the brain of an animal. Anodal block was induced using simple wire electrodes. Experiments showed that by increasing anodal blocking current from 50 to 350 microamperes signal conduction in C type fibers was gradually reduced from 100% to 0% (complete block) in linear proportion to the strength of the electric current. Similarly increasing concentration of injected bupivacaine (5, 10, 20 and 100 mg/ml) resulted in gradual blocking of the carotid sinus nerve activity in a dog. These experiments confirmed that it is possible to reduce intensity of nerve stimulation (nerve traffic) in an isolated nerve in controllable, reversible and gradual was by the application of electric current or chemical blockade. In the same paper it was described that smaller C type fibers were blocked by lower electric current and higher concentration of bupivacaine than larger C type fibers.

[0102] Gerald DiBona in "Neural control of the kidney: functionally specific renal sympathetic nerve fibers" described the structure and role of individual nerve fibers controlling the kidney function. Approximately 96% of sym-

pathetic renal fibers in the renal nerve are slow conducting unmyelinated C type fibers 0.4 to 2.5 micrometers in diameter. Different fibers within this range carry different signals and respond to different levels of stimulation and inhibition. It is known that lower stimulation voltage of the renal nerve created untidiuretic effect (reduced urine output) while higher level of stimulation created vasoconstriction effect. Stimulation threshold is inversely proportional to the fiber diameter; therefore it is likely that elevated signal levels in larger diameter renal nerve C fibers are responsible for the retention of fluid in heart failure. Relatively smaller diameter C fibers are responsible for vasoconstriction resulting in the reduction of renal blood flow in heart failure.

[0103] FIG. 7 illustrates a simplified cross-section of the renal nerve trunk **601**. Trunk **601** consists of a number of individual fibers. The stimulation electrode cuff **603** envelops the nerve trunk. Larger C type fiber **705** exemplifies fibers responsible for diuresis. There are also other fibers **702** that can be for example afferent fibers. Traffic along these fibers can be blocked by the application of lower blocking voltage or lower dose of anesthetic drug. The resulting effect will be diuresis of the CHF patient (secretion of sodium and water by the kidney) and the relief of fluid overload. Smaller C fiber **704** is responsible for the regulation of renal blood flow.

[0104] In clinical practice, it may be desired to modulate or block selectively or preferably the larger fibers **705**. This can be achieved with lower levels of stimulation. The patient can be relieved of access fluid without significantly increasing renal blood flow since traffic in smaller C fibers will not be altered. Renal blood flow can amount to as much as 20% of cardiac output. In a CHF patient with a weakened heart significant increase of renal blood flow can lead to a dangerous decrease of arterial pressure if the diseased heart fails to pump harder to keep up with an increased demand for oxygenated blood. The nerve stimulator or signal generator **306** therefore is capable of at least two levels of stimulation: first (lower) level to block or partially block signals propagating in larger C fibers that control diuresis, and second (higher) level to block signals propagating in smaller C fibers that control renal vascular resistance and blood flow to the kidney. The later method of nerve traffic modulation with higher electric current levels is useful in preventing damage to kidneys in acute clinical situations where the vasoconstriction can lead to the ischemia of a kidney, acute tubular necrosis (ATN), acute renal failure and sometimes permanent kidney damage. This type of clinical scenario is often associated with the acute heart failure when hypotension (low blood pressure) results from a severe decompensation of a chronic heart failure patient. Acute renal failure caused by low blood flow to the kidneys is the most costly complication in patients with heart failure.

[0105] Similar differentiated response to modulation could be elicited by applying different frequency of electric pulses (overpacing) to the renal nerve and keeping the applied voltage constant. DiBona noted that renal fibers responsible for rennin secretion responded to the lowest frequency of pulses (0.5 to 1 Hz), fibers responsible for sodium retention responded to middle range of frequencies (1 to 2 Hz) and fibers responsible for blood flow responded to the highest frequency of stimulation (2 to 5 Hz). This approach can be used when the renal nerve block is achieved by overpacing the renal nerve by applying rapid series of electric pulses to the electrodes with the intent to fatigue the nerve to the point when it stops conducting stimulation pulses.

[0106] One embodiment of the method of treating heart failure comprises the following steps:

[0107] A. Introducing one or more electrodes in the close proximity with the renal nerve,

[0108] B. Connecting the electrodes to an electric stimulator or generator with conductive leads or wires,

[0109] C. Initiating flow of electric current to the electrodes sufficient to block or reduce signal traffic in the sympathetic efferent renal nerve fibers with the intention of increasing diuresis, reducing renal secretion of renin and vasodilation of the blood vessels in the kidney to increase renal blood supply.

[0110] FIG. 8 shows an alternative embodiment of the invention. In this embodiment the natural efferent signal traffic 804 entering the renal nerve trunk 601 is completely blocked by the anodal block device stimulator 306 using a pair of electrodes 604 and 603. The third electrode (or pair of electrodes) 803 is situated downstream of the block. The electrode is used to stimulate or pace the kidney. Stimulation signal is transmitted from the generator 306 via the additional lead wire 805 to the electrode 803. The induced signal becomes the nerve input to the kidney. This way full control of nerve input is accomplished while the natural sympathetic tone is totally abolished.

[0111] FIG. 9 shows the transvenous embodiment of the invention using anodal blockade to modulate renal nerve traffic. Renal nerve 601 is located between the renal artery 901 and the renal vein 902. It follows the same direction towards the kidney. Renal artery can branch before entering the kidney but in the majority of humans there is only one renal artery. Stimulation catheter or lead 903 is introduced into the renal vein 902 and anchored to the wall of the vein using a securing device 904. The securing device can be a barb or a screw if the permanent placement of the lead 903 is desired. Electric field 904 is induced by the electric current applied by the positively charged anode 905 and cathode 906 catheter electrodes. Electrodes are connected to the stimulator (not shown) by wires 907 and 908 that can be incorporated into the trunk of the lead 903. Electric field 904 is induced in the tissue surrounding the renal vein 902 and creates the desired local polarization of the segment of the renal nerve trunk 601 situated in the close proximity of the catheter electrodes 905 and 907. Similarly catheters or leads can be designed that induce a cathodal block, a collision block or fatigue the nerve by rapidly pacing it using an induced field rather than by contacting the nerve directly.

[0112] FIG. 10 shows an embodiment where the stimulation lead is placed using laparoscopic surgery. This technology is common in modern surgery and uses a small video-camera and a few customized instruments to perform surgery with minimal tissue injury. The camera and instruments are inserted into the abdomen through small skin cuts allowing the surgeon to explore the whole cavity without the need of making large standard openings dividing skin and muscle.

[0113] After the cut is made in the umbilical area a special needle is inserted to start insufflation. A pressure regulated CO₂ insufflator is connected to the needle. After satisfactory insufflation the needle is removed and a trocar is inserted through the previous small wound. This method reduces the recovery time due to its minimal tissue damage permitting the patient to return to normal activity in a shorter period of time. Although this type of procedure is known since the beginning of the 19th. century, it was not until the advent of high resolution video camera that laparoscopic surgery became very popular among surgeons. Kidney surgery including removal

of donor kidneys is routinely done using laparoscopic methodology. It should be easy for a skilled surgeon to place the lead 903 through a tunnel in tissue layers 1001 surrounding the renal nerve 601. This way lead electrodes 905 and 906 are placed in close proximity to the nerve and can be used to induce a block without major surgery.

[0114] FIG. 11 shows an implanted embodiment of the invention controlled by the patient from outside of the body. The implanted stimulation device 203 is an electric stimulation device to modulate the renal nerve signal but can be an implantable infusion pump capable of infusing a dose of an anesthetic drug on command. The implantable device 203 incorporates a magnetically activated switch such as a reed relay. The reed switch can be a single-pole, single-throw (SPST) type having normally open contacts and containing two reeds that can be magnetically actuated by an electromagnet, permanent magnet or combination of both. Such switch of extremely small size and low power requirements suitable for an implanted device is available from Coto Technology of Providence, R.I. in several configurations. Switch is normally open preventing electric or chemical blockade of the renal nerve 209. When the patient brings a magnet 1101 in close proximity to the body site where the device 202 is implanted the magnetic field 1103 acts on the magnetic switch 1102. Switch is closed and blocking of the renal nerve is activated. The resulting reduction of the sympathetic tone commands the kidney 208 to increase the production of urine. Patient can use the device when they feel the symptoms of fluid overload to remove excess fluid from the body. The device 202 can be equipped with a timing circuit that is set by the external magnet. After the activation by the magnet the device can stay active (block renal nerve activity) for a predetermined duration of time to allow the kidney to make a desired amount of urine such as for an hour or several hours. Then the device will time out to avoid excessive fluid removal or adaptation of the renal nerve to the new condition.

[0115] FIG. 12 illustrates the progression of CRF to ESRD. Following the original injury to the kidney 1201 some nephrons 1202 are lost. Loss of nephrons lead to hyperfiltration 1203 and triggers compensatory mechanisms 1204 that are initially beneficial but over time make injury worse until the ESRD 1208 occurs. Compensatory mechanisms lead to elevated afferent and efferent sympathetic nerve signal level (increased signal traffic) 1207 to and from the kidney. It is the objective of this invention to block, reduce, modulate or otherwise decrease this level of stimulation.

[0116] The effect of the invented therapeutic intervention will be the reduction of central (coming from the brain) sympathetic stimulation 1206 to all organs and particularly blood vessels that causes vasoconstriction and elevation of blood pressure. Following that hypertension 1205 will be reduced therefore reducing continuous additional insult to the kidney and other organs.

[0117] FIG. 13 illustrates the physiologic mechanisms of CRF and hypertension. Injured kidney 1302 sends elevated afferent nerve 1306 signals to the brain 1301. Brain in response increases sympathetic efferent signals to the kidney 1307 and to blood vessels 1311 that increase vascular resistance 1303 by vasoconstriction. Vasoconstriction 1303 causes hypertension 1304. Kidney 1302 secretes renin 1310 that stimulates production of the vasoconstrictor hormone Angiotensin II 1305 that increases vasoconstriction of blood vessels 1303 and further increases hypertension 1304. Hypertension causes further mechanical damage 1312 to the kidney

1302 while sympathetically activated neurohormones **1307** and angiotensin II causes more subtle injury via the hormonal pathway **1310**.

[0118] Invented therapy reduces or eliminates critical pathways of the progressive disease by blocking afferent **1306** and efferent **1307** signals to and from the kidney **1302**. Both neurological **1311** and hormonal **1309** stimulus of vasoconstriction are therefore reduced resulting in the relief of hypertension **1304**. As a result, over time the progression of renal disease is slowed down, kidney function is improved and the possibility of stroke from high blood pressure is reduced.

[0119] FIG. 14 shows a patient **201** suffering from CRF or renal hypertension treated in accordance with the invention. An implantable device **202** is implanted in the patient's body. An implantable device can be an electric nerve stimulator or a chemical substance (drug) infusion device. The implantable device **202** described above is equipped with the lead **204** connecting it to the renal nerve artery cuff **1401**. Cuff **1401** envelops the renal artery **203** that anatomically serves as a support structure for the renal nerve plexus. It is understood that there exist many varieties of electrode configurations such as wires, rings, needles, anchors, screws, cuffs and hooks that could all potentially be used to stimulate renal nerves. The cuff configuration **1401** illustrated by FIGS. 14, 15, 16 and 17 was selected for the preferred embodiment base on the information available to the inventors at the time of invention.

[0120] The lead conduit can be alternatively an electric wire or a catheter for delivery of medication or a combination of both. Renal nerve conducts efferent sympathetic stimulation from the sympathetic trunk **206** to the kidney **208**. Sympathetic trunk is connected to the patient's spinal cord inside the spine **207**. The lead to nerve connection can be located anywhere between the kidney **208** and the posterior renal or other renal ganglia (not shown) in the region of the 10th, 11th and 12th thoracic and 1st lumbar segments of the spine **207**. The stimulation lead **204** and the arterial nerve cuff **1401**, as selected for the preferred embodiment of the invention, can be placed using laparoscopic surgery.

[0121] FIG. 15 illustrates one possible embodiment of the renal nerve stimulation cuff electrode cuff. When the treated disease is CRF or hypertension it is the additional objective of this embodiment of the invention to selectively modulate nerve traffic in both afferent and efferent nerve fibers innervating the human kidney. Using existing selective modulation techniques it is possible to stimulate only afferent or efferent fibers. Different types of fibers have different structure and respond to different levels and frequency of stimulation. Anatomically renal nerve is difficult to locate in humans even during surgery. The autonomic nervous system forms a plexus on the external surface renal artery. Fibers contributing to the plexus arise from the celiac ganglion, the lowest splanchnic nerve, the aorticorenal ganglion and aortic plexus. The plexus is distributed with branches of the renal artery to vessels of the kidney, the glomeruli and tubules. The nerves from these sources, fifteen or twenty in number, have a few ganglia developed upon them. They accompany the branches of the renal artery into the kidney; some filaments are distributed to the spermatic plexus and, on the right side, to the inferior vena cava. This makes isolating a renal nerve difficult.

[0122] To overcome this anatomic limitation the preferred embodiment of the neurostimulation shown on FIG. 15 has an innovative stimulation cuff. The cuff **1401** envelops the renal

artery **203** and overlaps nerve fibers **1501** that form the renal plexus and look like a spider web. Cuff has at least two isolated electrodes **1402** and **1403** needed for nerve blocking. More electrodes can be used for selective patterns of stimulation and blocking. Electrodes are connected to the lead **204**. Renal artery **203** connects aorta **213** to the kidney **208**. It is subject to pulsations of pressure and therefore cyclically swells and contracts.

[0123] FIG. 16 further illustrates the design of the cuff **1401**. Cuff envelopes the renal artery **203**. Cuff is almost circumferential but has an opening **406**. When the artery cyclically swells with blood pressure pulses, the cuff opens up without damaging the nerve or pinching the artery. Opening **406** also allows placement of the cuff around the artery. Similar designs of nerve cuffs known as "helical" cuffs are well known, see e.g., U.S. Pat. Nos. 5,251,634; 4,649,936 and 5,634,462.

[0124] FIG. 17 shows the crosssection of the cuff **1401**. Cuff **1401** is made out of dielectric material. Two electrodes **1402** and **1403** form rings to maximize the contact area with the wall of the artery **203**.

[0125] Common to all the embodiments, is that an invasive device is used to decrease the level of renal nerve signals that are received by the kidney or generated by the kidney and received by the brain. The invention has been described in connection with the best mode now known to the applicant inventors. The invention is not to be limited to the disclosed embodiment. Rather, the invention covers all of various modifications and equivalent arrangements included within the spirit and scope of the appended claims.

[0126] Heart failure, also called congestive heart failure (CHF) and chronic heart failure is a progressive heart disease characterized by low cardiac output, deterioration of heart muscle and fluid retention. Renal failure, also called chronic renal failure (CRF) is a progressive degenerative renal disease that is characterized by gradual loss of renal function that leads to the end stage renal disease (ESRD). ESRD requires dialysis for life. Hypertension is the chronic disease associated with high probability of stroke, renal failure and heart failure that is characterized by the abnormally high blood pressure.

[0127] A nerve in the context of this application means a separate nerve or a nerve bundle, nerve fiber, nerve plexus or nerve ganglion. Renal nerve is a part of the autonomic nervous system that forms a plexus on the external surface renal artery. Fibers contributing to the plexus arise from the celiac ganglion, the lowest splanchnic nerve, the aorticorenal ganglion and aortic plexus. The plexus is distributed with branches of the renal artery to blood vessels of the kidney, the glomeruli and tubules. The nerves from these sources, have a few ganglia developed upon them. They accompany the branches of the renal artery into the kidney; some filaments are distributed to the spermatic plexus and, on the right side, to the inferior vena cava.

[0128] Nerve stimulation, neurostimulation, nerve modulation and neuromodulation are equivalent and mean altering (reducing or increasing) naturally occurring level of electric signals propagating through the nerve. The electric signal in the nerve is also called nerve traffic, nerve tone or nerve stimulus.

[0129] Nerve block, blocking or blockade is a form of neuromodulation and means the reduction or total termination of the propagation or conduction of the electric signal along the selected nerve. Nerve block can be pharmacological (induced

by a drug or other chemical substance) or an electric block by electrostimulation. Electric nerve block can be a hyperpolarization block, cathodal, anodal or collision block. Overpacing a nerve can also induce a block. Overpacing means stimulating the nerve with rapid electric pulses at a rate that exceeds the natural cycling rate of the nerve polarization and depolarization. As a result of overpacing the nerve gets fatigued, reserves of the immediately available neurotransmitter substance in the nerve become exhausted, and the nerve becomes temporarily unable to conduct signals. Nerve block by the means listed above can result in the reduction of the nerve signal, in particular the renal sympathetic efferent or afferent tone that determines the electric stimulus received or generated by the kidney. The technique of the controlled reduction of the nerve signal or traffic, which results in less organ stimulation, is called nerve signal modulation. Nerve modulation means that the individual nerve fibers fire with a reduced frequency or that fewer of the nerve fibers comprising the renal nerve are actively conducting or firing. The increase of nerve traffic or nerve activity usually involves recruitment of larger number of fibers in the nerve; alternatively less stimulation is associated with less active fibers. Denervation means blocking of the renal nerve conduction or the destruction of the renal nerve.

[0130] Lead is a medical device used to access the nerve designated for stimulation or blocking. It is usually a tubular device that is electrically insulated and includes multiple conductors or wires. Wires conduct stimulation or blocking signals from the stimulator to the designated nerve. Wires are terminated in electrodes. Electrodes are conductive terminals and can contact the nerve directly or contact the conductive tissue in the vicinity of the nerve. Electrodes can have different geometric configurations and can be made of different materials. The lead can include lumens or tubes for drug delivery to the nerve. A stimulator or an electrostimulator is an electric device used to generate electric signals that are conducted by the lead to the nerve. The stimulator can be implanted in the body or external. Electric signals can be a DC current, voltage, series of pulses or AC current or voltage. Electrodes can induce an electric field that affects the nerve and results in nerve blocking. Nerve cuff is a support structure that at least partially envelops the targeted nerve.

[0131] While the invention has been described in connection with what is presently considered to be the most practical and preferred embodiment, it is to be understood that the invention is not to be limited to the disclosed embodiment, but on the contrary, is intended to cover various modifications and equivalent arrangements included within the spirit and scope of the appended claims.

What is claimed is:

1. A method for treating a human patient comprising:
 - a. positioning a nerve stimulation device adjacent to a renal nerve of at least one kidney of the patient, and
 - b. at least partially blocking the renal nerve of the kidney.
2. A method as in claim 1 wherein the nerve stimulation device is an electrode, and the electrode is positioned surgically in the patient.
3. A method as in claim 1 wherein the nerve stimulation device is a drug delivery device, and the device is positioned surgically in the patient.
4. A method as in claim 1 where the nerve stimulation device is placed in a renal vein of the kidney.
5. A method as in claim 1 where the nerve stimulation device is placed in a renal artery of the kidney.

6. The method of claim 1 wherein the nerve stimulation device is a cuff placed around a renal artery of the kidney.

7. The method of claim 1 wherein the nerve stimulation device is implanted in the patient.

8. The method as in claim 1 wherein afferent fibers of the renal nerve are blocked and efferent fibers are not blocked.

9. The method as in claim 1 wherein efferent fibers of the renal nerve are blocked and afferent fibers are not blocked.

10. A method as in claim 1 wherein the step of blocking the renal nerve is accomplished by a block selected from a group consisting of an anodal block, a cathodal block and a collision block.

11. A method as in claim 1 wherein the step of blocking the renal nerve is accomplished by overpacing the nerve.

12. A method as in claim 1 wherein the step of blocking is accomplished by continuous infusion of an anesthetic drug to the nerve.

13. A method as in claim 1 further comprising monitoring blood pressure of the patient, and adjusting a level of blocking in response to said blood pressure.

14. A method as in claim 1 wherein the nerve stimulation device is a catheter.

15. A method as in claim 1 wherein the nerve stimulation device is a lead with multiple electrode.

16. A method as in claim 1 wherein the step of blocking is accomplished by the injection of a neurotoxin.

17. A method as in claim 1 wherein the step of blocking is accomplished by ablation of the renal nerve.

18. A method as in claim 1 wherein the step of blocking is accomplished by cooling of the renal nerve.

19. A method as in claim 1 applied to a patient suffering from at least one of heart failure, chronic renal failure and hypertension.

20. A method to stimulate a renal nerve in a mammalian patient comprising:

- a. positioning a nerve stimulation device proximate a renal nerve of a kidney of the patient;
- b. applying a stimulation signal with the device to the renal nerve, and
- c. at least partially blocking the renal nerve by application of the stimulation signal.

21. A method as in claim 20 wherein the nerve stimulation device is an electrode, and the stimulation signal is an electrical current applied by the electrode to the renal nerve.

22. A method as in claim 20 wherein the nerve stimulation device is a drug delivery device and the stimulation signal is a nerve blocking drug applied to the renal nerve.

23. A method as in claim 20 wherein the nerve stimulation device is coupled to a renal blood vessel proximate the renal nerve.

24. A method as in claims 20 wherein the nerve stimulation device is a cuff applied to a renal blood vessel proximate the renal nerve, and the cuff applies a stimulation signal to the renal nerve.

25. A method for reducing abnormally elevated sympathetic renal nerve signals comprising:

- a. positioning at least one electrode proximate to a renal nerve of a mammalian patient;
- b. applying an electrical current to the electrode with an electric controller to stimulate the renal nerve to at least reduce signal traffic in sympathetic efferent renal nerve fibers, and

- c. said controller regulating the current applied to the electrode based on at least one condition of the patient being monitored by a sensor.
- 26.** A method as in claim **25** wherein the controller monitors blood pressure in the patient and the sensor is a blood pressure sensor.
- 27.** A method as in claim **25** wherein the controller monitors blood oxygen in the patient and the sensor is a blood oxygen sensor.
- 28.** An apparatus for reducing abnormally elevated sympathetic comprising:
 a nerve stimulation device to be placed proximate to a renal nerve of the patient and said device adapted to stimulate the renal nerve, and
 a nerve stimulator activating the stimulation device to stimulate the renal nerve.
- 29.** An apparatus as in claim **28** wherein the stimulation device is an electrode and said stimulator is a controller that applies an electrical current to the electrode.
- 30.** An apparatus as in claim **28** wherein the stimulation device is a drug delivery catheter insertable into a renal blood vessel, and said stimulator is a drug dispenser coupled to said catheter.
- 31.** An apparatus as in claim **28** further comprising a patient sensor connectable to said stimulator, wherein said stimulator receives a signal from the sensor indicative of a condition of the patient and controls the activation of the stimulation device based on said signal.
- 32.** An apparatus as in claim **31** wherein said sensor is a blood pressure sensor and said condition is a blood pressure level of the patient.
- 33.** An apparatus as in claim **31** wherein said sensor is a blood oxygen sensor and said condition is a blood oxygen level of the patient.
- 34.** An apparatus as in claim **28** wherein the said stimulator dispenses drug an anesthetic drug periodically into the said catheter.
- 35.** An apparatus for reducing abnormally elevated sympathetic comprising:
 a nerve stimulation device positionable proximate to a renal blood vessel of the patient and said device adapted to stimulate a renal nerve adjacent the vessel, and
 a nerve stimulator activating the stimulation device to stimulate the renal nerve.
- 36.** A nerve stimulation device implantable in a mammalian patient comprising:
 an implantable stimulator,
 an implantable lead connected to said stimulator,
 an implanted nerve stimulation cuff connectable to said lead and adapted to receive signals generated by the stimulator, wherein said cuff at least partially envelopes an artery.
- 37.** A nerve stimulation device as in claim **36** wherein said cuff is at least partially attached to an external surface of an artery
- 38.** A nerve stimulation device comprising:
 a stimulator implantable into a mammalian patient,
 a nerve stimulation cuff in communication with said stimulator to receive a nerve stimulation signal for the stimulator, and said cuff adapted to be implanted into the patient and positioned proximate to an outer surface of an artery of the patient, wherein said cuff stimulates a nerve adjacent the artery when activated by the nerve stimulation signal.
- 39.** A nerve stimulation device as in claim **38** wherein said cuff is adapted to at least partially envelopes the said artery.
- 40.** A nerve stimulation device as in claim **38** wherein said cuff dispenses a drug to the artery and the stimulator is a drug dispensing device.
- 41.** A nerve stimulation device as in claim **38** wherein said stimulator is an electrostimulator.
- 42.** A nerve stimulation device as in claim **38** wherein said cuff includes electrodes.
- 43.** A nerve stimulation device as in claim **38** further comprising a catheter lead extending from the stimulator to the cuff.

* * * * *