

W. Montgomery.
Loom Picker Check.

N^o 102,145.

Patented Apr. 19, 1870.

Fig. 1.

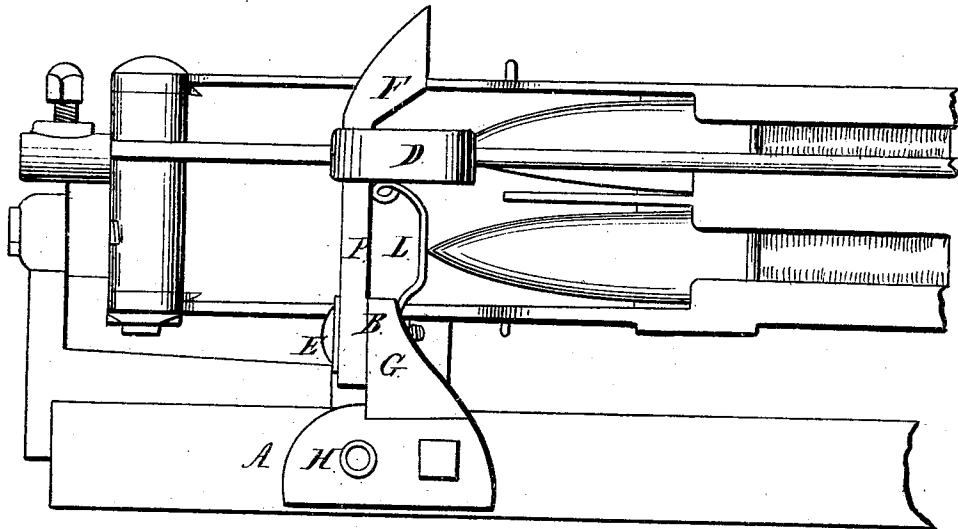
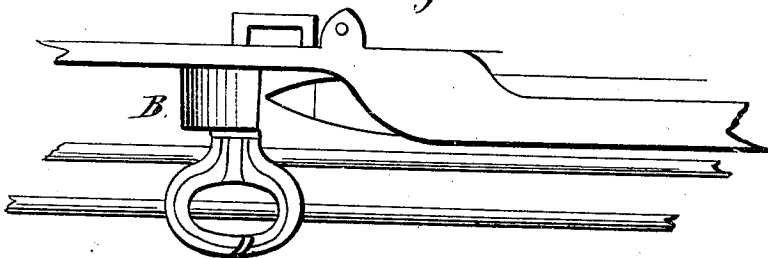

Fig. 2.



Witnesses:
Edw. Callan
J. Fowler

Inventor:
Wm. Montgomery
by his attorneys
Gardner & Hyde

United States Patent Office.

WILLIAM MONTGOMERY, OF NORTHAMPTON, MASSACHUSETTS.

Letters Patent No. 102,145, dated April 19, 1870.

IMPROVEMENT IN PICKER-CHECK FOR LOOMS.

The Schedule referred to in these Letters Patent and making part of the same.

To all whom it may concern:

Be it known that I, WILLIAM MONTGOMERY, of Northampton, Hampshire county, State of Massachusetts, have invented a new and useful Improvement in Spring Picker-Checks for Looms; and I do hereby declare that the following is a full and exact description thereof, reference being had to the accompanying drawings and to the letters of reference marked thereon.

The object of my invention is to form a durable and economical shuttle-rebounder for looms.

In the drawings—

Figure I is a plan view, and

Figure II, a detail view.

The spring B is constructed of a peculiarly-shaped piece of tough and elastic wood, P, joined by the screw-nut E to an iron shank, G, which has a flange, M, at right angles to it, having two or more holes for the reception of the bolts, which secure it firmly to the iron head of the shuttle-box A, so that in attaching a new spring to the box-head no more time is required than to screw the bolts in their place.

At the inner end of the piece P, at a point just inside of the place where the picker D comes against the wooden spring P, projects a butt, F.

The face of this butt is in the same plane with the

striking surface of the picker, and when the shuttle-box is being lowered the shuttles therein, if too far out of their boxes, may be pushed in, so that their points will not catch against the picker.

Attached by the screw and nut E (to the spring) at its outer end, and having the inner resting against the part P, is a piece of sheet metal, L, bent so as to have a flat surface on a line with the faces of the picker D and butt F, and this spring serves to move the shuttles into the box as it rises, so that their points will not catch the picker.

This spring is noiseless and cheap, and, owing to its peculiar form and construction, takes little time to attach.

Now, having described my invention,

What I claim as new, and desire to secure by Letters Patent, is—

The combination, with the picker, of the wooden check-piece P, having butt F, the metal shank G, having flange H, and the bent piece of sheet metal L, the whole constructed and arranged substantially as shown.

WM. MONTGOMERY.

Witnesses:

J. B. GARDINER,
E. R. FITCH.