



(11) **EP 2 037 187 A2**

(12) **EUROPEAN PATENT APPLICATION**

(43) Date of publication:
18.03.2009 Bulletin 2009/12

(51) Int Cl.:
F24F 1/00^(2006.01) F24F 13/20^(2006.01)

(21) Application number: **08252264.0**

(22) Date of filing: **02.07.2008**

(84) Designated Contracting States:
AT BE BG CH CY CZ DE DK EE ES FI FR GB GR HR HU IE IS IT LI LT LU LV MC MT NL NO PL PT RO SE SI SK TR
Designated Extension States:
AL BA MK RS

(30) Priority: **13.09.2007 KR 20070093334**

(71) Applicant: **LG Electronics Inc.**
Youngdungpo-ku
Seoul (KR)

(72) Inventors:
• **Jang, Seok Hoon**
Changwon City, Gyoungsangnam-do 641-711 (KR)

- **Kim, Byoung Sup**
Changwon City, Gyoungsangnam-do 641-711 (KR)
- **Kwon, Joon Hyuk**
Changwon City, Gyoungsangnam-do 641-711 (KR)
- **Noh, Woong Seok**
Changwon City, Gyoungsangnam-do 641-711 (KR)
- **Pack, Eun Seong**
Changwon City, Gyoungsangnam-do 641-711 (KR)

(74) Representative: **Palmer, Jonathan R.**
Boult Wade Tennant
Verulam Gardens
70 Gray's Inn Road
London WC1X 8BT (GB)

(54) **Outdoor unit of air conditioner**

(57) An outdoor unit of an air conditioner is provided. The outdoor unit includes a base assembly defining a lower exterior of the outdoor unit and supporting a plurality of components and an accumulator that is installed above the base assembly to filter off liquefied refrigerant

from refrigerant entering a compressor. The accumulator includes a mounting unit enabling at least one of other components to be mounted on the accumulator.

EP 2 037 187 A2

Description

BACKGROUND

[0001] The present disclosure relates to an outdoor unit of an air conditioner, which has an accumulator provided with a mounting unit to which a variety of other components can be coupled.

[0002] In general, an air conditioner is a cooling/heating system that cools an indoor environment by continually performing a cycle of suctioning warm air from the indoor environment, performing heat exchange between the air and cold refrigerant, and expelling the cooled air back into the indoor environment. For heating, reverse conditions are employed to heat the indoor environment. The air conditioner defines a series of cycles using a compressor, condenser, expansion valve, and evaporator.

[0003] The typical air conditioners may be divided largely into split type air conditioners with outdoor and indoor units that are installed separately from each other, and integrated type conditioners with the outdoor and indoor units that are integrally installed with each other.

[0004] A relatively recent phenomenon is the widespread use of multi-unit air conditioners that are effectively applied in households wanting to install two or more air conditioners, and in buildings with multiple offices that require respective air conditioners. The multi-unit air conditioner connects one outdoor unit to a plurality of indoor units to achieve the same effect as a case where a plurality of the split type air conditioners are installed.

[0005] Meanwhile, a variety of components such as an accumulator and a super cooler in addition to the compressor are installed in the air conditioner. Such components are generally mounted on a base assembly defining a lower exterior of the outdoor unit.

[0006] However, since the components are independently installed on the base assembly, an area of the base assembly is unnecessarily enlarged and thus an overall size of the produce increases.

SUMMARY

[0007] Accordingly, it would be desirable to provide an outdoor unit of an air conditioner, which has an accumulator on which a variety of components can be detachably mounted.

[0008] In an embodiment, an outdoor unit of an air conditioner includes a base assembly defining a lower exterior of the outdoor unit and supporting a plurality of components; and an accumulator that is installed above the base assembly to filter off liquefied refrigerant from refrigerant entering a compressor, wherein the accumulator comprises a mounting unit enabling at least one of other components to be mounted on the accumulator.

[0009] According to the embodiment, the mounting unit is provided on a surface of the accumulator. Therefore, a component such as a super cooler can be mount-

ed on the accumulator by the mounting unit, an overall size of the air conditioner can be reduced.

[0010] That is, since at least one of a variety of components installed on the base assembly is installed on the accumulator, an internal space of the outdoor unit and the base assembly can be downsized.

[0011] In addition, the mounting unit provided on the accumulator may be designed such that an end of the component can be hooked on the accumulator. Therefore, since a screw-coupling work can be conveniently performed in a state where the end of the component is hooked on the accumulator, the working efficiency can be improved.

[0012] The details of one or more embodiments are set forth in the accompanying drawings and the description below. Other features will be apparent from the description and drawings, and from the claims.

BRIEF DESCRIPTION OF THE DRAWINGS

[0013]

FIG. 1 is a perspective view of an outdoor unit according to an exemplary embodiment of the present disclosure.

FIG. 2 is an exploded perspective view of the outdoor unit of FIG. 1.

FIG. 3 is a partial perspective view illustrating an installed state of an accumulator depicted in FIG. 2.

FIG. 4 is an exploded perspective view illustrating a coupling state of a super cooler and an accumulator that are depicted in FIG. 2.

DETAILED DESCRIPTION OF THE EMBODIMENTS

[0014] Reference will now be made in detail to the embodiments of the present disclosure, examples of which are illustrated in the accompanying drawings.

[0015] FIG. 1 is a perspective view of an outdoor unit according to an exemplary embodiment of the present disclosure. Specifically, FIG. 1 exemplarily shows a type of outdoor unit for an air conditioner that discharges air upwards.

[0016] As shown in FIG. 1, the outdoor unit 10 is formed in a box shape and connected through pipes to a plurality of indoor units (not shown). Refrigerant flows between the outdoor and indoor units.

[0017] The outdoor unit 10 includes a base assembly 100 defining a lower exterior and a cabinet 200 defining an upper exterior. That is, the cabinet 200 is disposed on the base assembly 100. The outdoor unit 10 further includes an outlet grills G having an octagonal shape (when viewed from a top) and protruding upward from a top surface of the cabinet 200. The air is discharged out of the outdoor unit 10 through the outlet grills G.

[0018] FIG. 2 is an exploded perspective view of the outdoor unit 10.

[0019] As shown in FIG. 2, the cabinet 200 is formed

with a plurality panels. In more detail, the cabinet 200 includes a pair of front panels 210 and 212 that are provided at a front end of the base assembly 100 to define a front exterior of the outdoor unit. That is, the front panels 210 and 212 are respectively installed on left and right sides at the front end of the base assembly 100. A front center frame 220 is vertically elongated between the front panels 210 and 212.

[0020] The cabinet 200 further includes a pair of front upper panels 230 and 232 provided above the respective front panels 210 and 212. The front upper panels 230 and 232 define a front upper exterior of the outdoor unit and are installed at the left and right above the respective panels 210 and 212, respectively. A front upper frame 240 is further provided between the front upper panels 230 and 232. The front upper frame 240 is shaped correspondingly to the front center frame 220 to support the pair of front upper panels 230 and 232.

[0021] A left panel 250 and a right panel 260 are respectively provided at the left and right ends of the base assembly 100, defining left and right external facets of the outdoor unit. Also, a left grill 252 is integrally formed with the left panel 250, and a right grill 262 is integrally formed with the left panel 260. Thus, external air is able to enter the outdoor unit 10 through the left and right grills 252 and 262.

[0022] A pair of rear grills 270 is provided at an upper rear end of the base assembly 100. The rear grills 270 define the rear exterior surface, and the external air also enters the outdoor unit 10 through the rear grills 270.

[0023] A rear center frame (not shown) corresponding to the front center frame 220 is further provided at a central portion of the rear grills 270 to support the pair of rear grills 270.

[0024] A pair of top panels 280 and 282 is provided between top ends of the left and right panels 250 and 260 to define the top exterior of the outdoor unit. That is, the external top surface of the outdoor unit 10 is defined by the rectangular left top panel 280 and right top panel 282. An outlet 284 is defined vertically through each of the pair of top panels 280 and 282.

[0025] Also, outlet grills G are installed on the outlets 284. The outlet grills G prevent impurities from the outside from entering through the outlets 284, and also allow the air to be discharged upwards out of the outdoor unit.

[0026] A pair of rear upper panels 290 and 292 is further provided at the top of the pair of rear grills 270. The rear upper panels 290 and 292 define the rear upper exterior of the outdoor unit, and are formed to have a shape corresponding to the front upper panels 230 and 232.

[0027] Accordingly, the rear upper panels 290 and 292 are respectively disposed at left and right sides, and a rear upper frame 294 is further provided between the rear upper panels 290 and 292. The rear upper frame 294 is formed in a shape corresponding to the front upper frame 240, and supports the pair of rear upper panels 290 and 292.

[0028] A frame assembly 300 is provided within the cabinet 200. The frame assembly 300 is installed on upper ends of the front panels 210 and 212 to support shrouds 420 and 422, a blower fan 400, and other components, which will be described below.

[0029] A pair of blower fan 400 and a fan motor 410 are installed at the top of the frame assembly 300. The pair of blower fans 400 is enclosed by a pair of shrouds 420 and 422. That is, the shrouds 420 and 422 having the same shape are installed on left and right sides at the top of the frame assembly 300, and the blower fan 400 is disposed to the inside of the pair of shrouds 420 and 422.

[0030] A heat exchanger 450 is installed within the cavity 200. The heat exchanger 450 functions to exchange heat between refrigerant flowing therein and air from the outside, and is installed on the upper left end, rear end, and right end of the base assembly 100. That is, the heat exchanger 450 is formed in a 'U' shape, that is an inverted "U" shape, as shown (when viewed from above).

[0031] FIG. 3 is a partial perspective view illustrating an installed state of a component on the base assembly 100.

[0032] As shown in FIG. 3, a compressor 460 for compressing refrigerant is installed on the base assembly 100 and an accumulator 470 for filtering liquefied refrigerant from the refrigerant flowing toward the compressor 460 is installed beside the compressor 460 on the base assembly 100.

[0033] A super cooler 480 is fixedly coupled to a surface of the accumulator 470. The super cooler 480 serves to further cool the refrigerant that is cooled as it passes through the heat exchanger 450. For example, a plate heat exchanger may be used as the super cooler 480.

[0034] The plate heat exchanger includes a plurality of thin plates that are spaced apart from each other at predetermined intervals to define spaces along which the refrigerant and cooling water flow. Refrigerant flows through each of the spaces defined between the plurality of thin plates to perform heat exchange.

[0035] FIG. 4 is an exploded perspective view of the accumulator 470 and the super cooler 480.

[0036] Referring to FIG. 4, the accumulator 470 includes a main body 472 defining a refrigerant receiving chamber and inlet and outlet pipes 474 and 476 that communicate with the refrigerant receiving chamber defined by the main body 472 to guide the flow of the refrigerant into or out of the main body 472, inside of the main body 472.

[0037] The main body 472 is formed in a cylindrical shape and erected upright. The inlet pipe 474 penetrates the top of the main body 474. A lower end portion of the inlet pipe 474 is bent toward an inner wall of the main body 474.

[0038] The bending of the lower end portion of the inlet pipe 474 toward the inner wall of the main body 474 incurs cyclone flow of the refrigerant introduced into the main body 472 through the inlet pipe 474. When the refrigerant

spirally flows by the cyclone flow, the separation of the liquefied refrigerant from the gaseous refrigerant can be easily realized.

[0039] The outlet pipe 476 is also formed to penetrate the top of the main body 472 and partly projected above the top of the main body 472.

[0040] A plurality of supporting legs (e.g., three or four legs) 478 are formed on a lower end of the main body 472. The supporting legs 478 support the accumulator 470 on the base assembly 100.

[0041] The accumulator 470 is provided with a mounting unit on which at least one component such as the super cooler 480 or other components can be supported. The mounting unit is provided on, for example, an outer circumference of the main body 470.

[0042] In more detail, the mounting unit includes a hook unit 500 by which the component (e.g., the super cooler 480) can be hooked on a surface of the main body 472 of the accumulator 470 and a coupling unit 510 for allowing a lower end of the super cooler 480 to be coupled to the surface of the main body 472 of the accumulator 470.

[0043] The hook unit 500 enables the super cooler 480 to be fixed in a state where the super cooler 480 is hooked on the outer circumference of the main body 472 of the accumulator 470. The hook unit 500 includes a pair of first hook members 502 formed on the outer circumference of the main body 472 of the accumulator 470 and a pair of second hook members 504 formed on an upper end of the super cooler 480.

[0044] The first hook members 502 and the second hook members 504 are configured to be hooked one another. For example, the first hook members 502 are respectively formed in 'D' and 'C' shapes, that is opposing "C" shapes (when viewed from a top) and the second hook members 504 are respectively formed in a 'U' shape (when viewed from a side).

[0045] The coupling unit 510 is for allowing the lower end of the super cooler 480 to be fixed on the outer circumference of the main body 472 of the accumulator 470 by, for example, screws. The coupling unit 510 includes first coupling members 512 formed on the main body 472 of the accumulator 470 and second coupling member 514 formed on a lower end of the super cooler 480.

[0046] The first coupling members 512 is shaped to correspond to the second coupling members 514. For example, the first coupling members 512 are formed in a 'J' shape (when viewed from a top), and the second coupling member 514 are formed in a 'L' shape (when viewed from a top). That is, the first coupling members 512 and the second coupling member 514 are formed in opposing "L" shapes.

[0047] The first hook members 502 and the first coupling members 512 are provided at front surfaces with respective coupling holes 520 in which the screws are coupled. The second hook members 504 and the second coupling members 514 are provided at front surfaces with respective through holes 520 through which the screws

pass.

[0048] The following will describe a process for mounting the super cooler 480 on the accumulator 470.

[0049] First, a worker lifts the super cooler 480 and moves downward the super cooler 480 in a state where the super cooler 480 closely contacts the outer circumference of the main body 472 of the accumulator 470. Then, the front surfaces of the first hook members 502 inserted into the second hook members 504 and thus the upper end of the super cooler 480 is hooked on the accumulator 470.

[0050] In this state, even when the worker releases the super cooler 480, the super cooler 480 maintains its hooked state on the main body. Therefore, the worker can do other works. That is, the worker inserts the screws into the through holes 522 of the second hook members 504 and couples the screws to the coupling holes 520, thereby completing the coupling of the upper end of the super cooler 480.

[0051] Next, the worker inserts the screws into the through holes 522 of the second coupling members 514 and then couples the screws to the coupling holes 520 of the first coupling members 512, thereby completing the coupling of the lower end of the super cooler 480.

[0052] In order to separate the super cooler 480 from the main body 472 of the accumulator 470, the above-described coupling process is done in a reverse direction.

[0053] The mounting unit functions to guide an arrangement of electric wires as well as to mount the component on the accumulator 470. That is, a variety of wires of the outdoor unit may be hung on the mounting unit or fixed to the mounting unit by separate coupling members. Alternatively, the wires may be supported on the mounting unit by being knotted itself around the mounting unit.

[0054] Although embodiments have been described with reference to a number of illustrative embodiments thereof, it should be understood that numerous other modifications and embodiments can be devised by those skilled in the art that will fall within the scope of the principles of this disclosure, as defined by the claims.

[0055] For example, although the super cooler 480 is coupled to the accumulator 470 by the mounting unit in the above embodiment, the present disclosure is not limited to the embodiment. That is, a variety of other components may be coupled to the accumulator 470 by the mounting unit.

[0056] In more detail, a dryer for removing moisture from the refrigerant, a receiver that is disposed near an outlet of the heater exchanger 450 to store condensed, liquefied refrigerant, an oil separator for separating oil from the refrigerant discharged from the compressor 460, or the like may be mounted on the accumulator 470 by the mounting unit.

Claims

1. An outdoor unit for an air conditioner, the outdoor

- unit comprising a base assembly defining a lower exterior of the outdoor unit and supporting a plurality of components and an accumulator that is installed above the base assembly to filter off liquefied refrigerant from refrigerant entering a compressor, **characterized in that** the accumulator comprises a mounting unit enabling at least one of other components to be mounted on the accumulator.
2. The outdoor unit according to claim 1, wherein the accumulator comprises a main body defining a refrigerant receiving chamber and inlet and outlet pipes that communicate with the refrigerant receiving chamber to guide flow of the refrigerant into or out of the refrigerant receiving chamber; and the mounting unit is provided on a surface of the main body of the accumulator.
3. The outdoor unit according to claim 2, wherein the component mounted on the accumulator by the mounting unit is a super cooler.
4. The outdoor unit according to claim 3, wherein the super cooler is a plate heat exchanger.
5. The outdoor unit according to claim 4, wherein the mounting unit comprises:
- a hook unit enabling an end of the super cooler to be hooked on the surface of the accumulator; and
 - a coupling unit enabling another end of the super cooler to be coupled to the accumulator.
6. The outdoor unit according to claim 5, wherein the hook unit enables an upper end of the super cooler to be hooked and fixed on an outer circumference of the main body of the accumulator.
7. The outdoor unit according to claim 6, wherein the hook unit comprises:
- a pair of first hook members formed on the outer circumference of the main body of the accumulator; and
 - a pair of second hook members formed on the upper end of the super cooler.
8. The outdoor unit according to claim 5, wherein the coupling unit enables a lower end of the super cooler to be fixed on an outer circumference of the main body of the accumulator.
9. The outdoor unit according to claim 8, wherein the coupling unit comprises:
- a coupling member formed on the outer circumference of the main body of the accumulator; and
- a second hook member formed on the lower end of the super cooler.
10. The outdoor unit according to claim 2, wherein the component coupled to the accumulator by the mounting unit is a dryer.
11. The outdoor unit according to claim 2, wherein the component coupled to the accumulator by the mounting unit is a receiver (a refrigerant storing unit).
12. The outdoor unit according to claim 2, wherein the component coupled to the accumulator by the mounting unit is an oil separator.
13. The outdoor unit according to claim 2, wherein the mounting unit functions to fix or support wires.

FIG.1

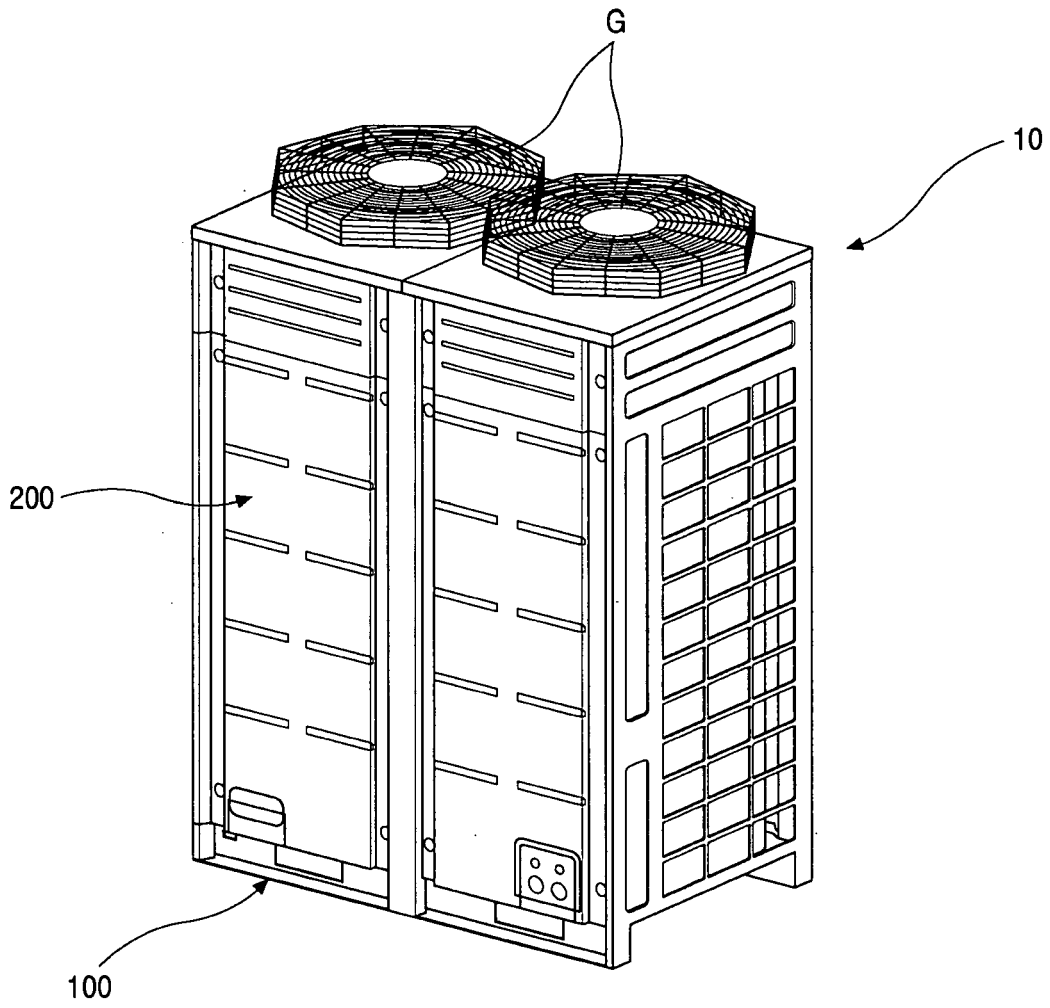

FIG.2

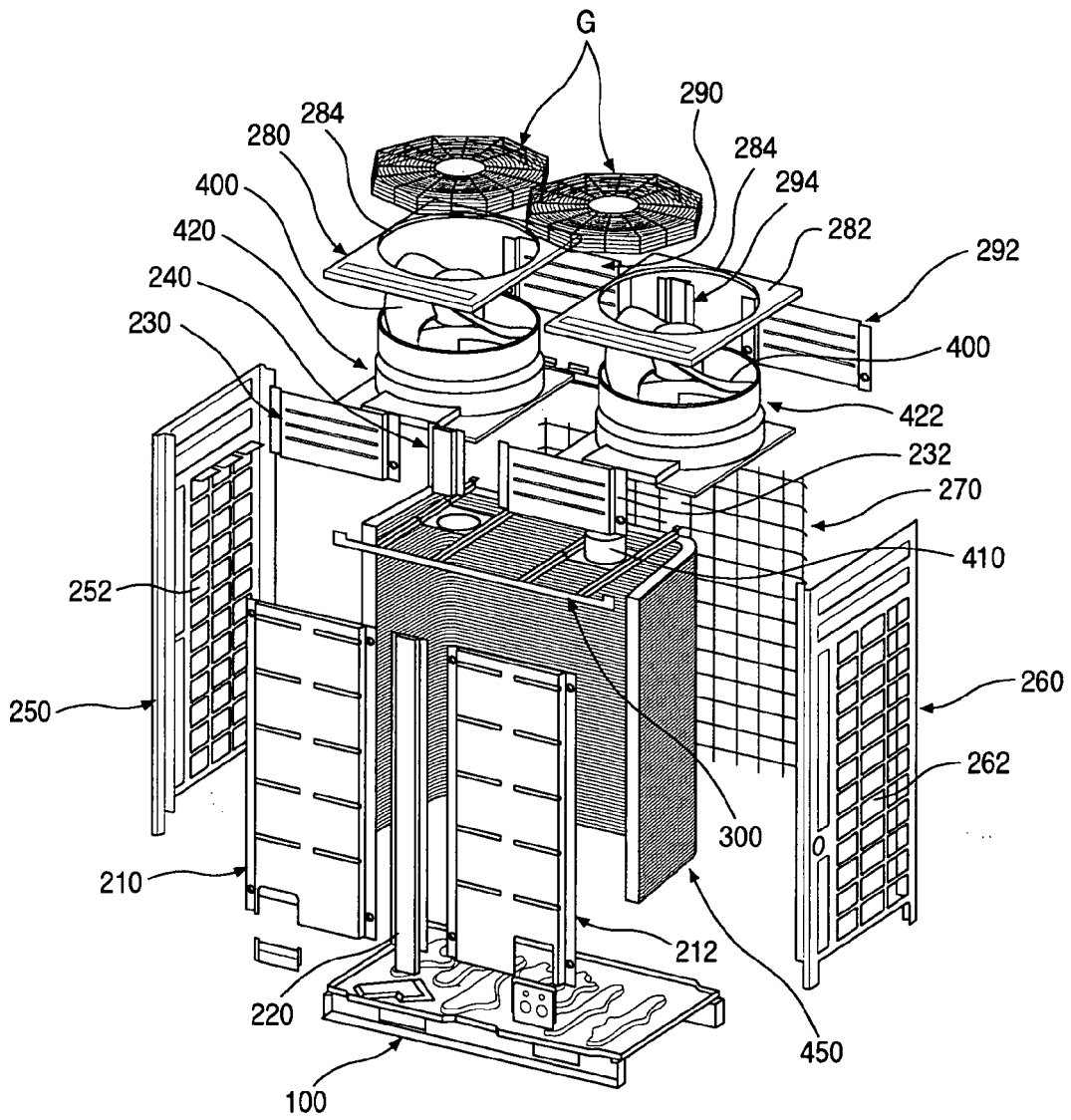

FIG.3

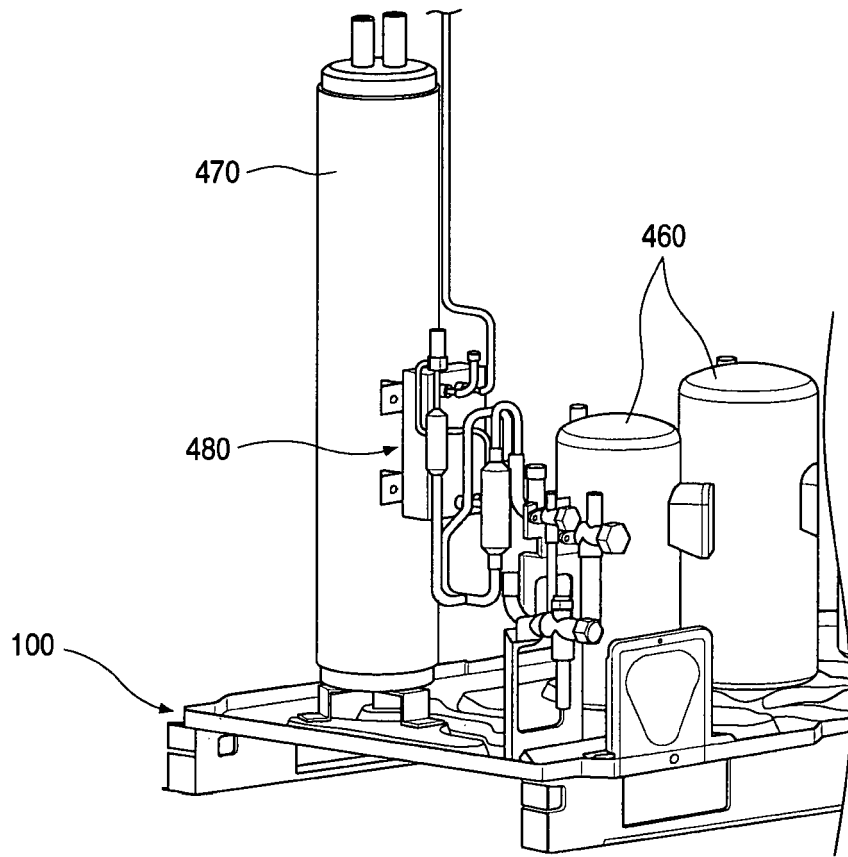

FIG. 4

