



US 20230013020A1

(19) **United States**

(12) **Patent Application Publication**
Holford

(10) **Pub. No.: US 2023/0013020 A1**

(43) **Pub. Date: Jan. 19, 2023**

(54) **ARTICLE FOR USE IN AN AEROSOL PROVISION SYSTEM**

A24D 3/06 (2006.01)

A24D 1/02 (2006.01)

A24F 40/20 (2006.01)

A24C 5/01 (2006.01)

(71) Applicant: **Nicoventures Trading Limited**,
London (GB)

(72) Inventor: **Steven Holford**, London (GB)

(21) Appl. No.: **17/785,954**

(22) PCT Filed: **Dec. 18, 2020**

(86) PCT No.: **PCT/GB2020/053299**

§ 371 (c)(1),

(2) Date: **Jun. 16, 2022**

(52) **U.S. Cl.**

CPC *A24D 1/20* (2020.01); *A24D 1/04* (2013.01); *A24D 3/17* (2020.01); *A24D 3/043* (2013.01); *A24D 3/063* (2013.01); *A24D 1/027* (2013.01); *A24F 40/20* (2020.01); *A24C 5/01* (2020.01)

(57)

ABSTRACT

An article for use with a non-combustible aerosol provision device comprising a heater, the article comprising: an aerosol generating material comprising at least one aerosol forming material; and a first tubular body disposed downstream of the aerosol generating material, the first tubular body comprising filamentary tow; and a mouth end section disposed downstream of the first tubular body, wherein the article is configured such that when the article is inserted into the non-combustible aerosol provision device, the minimum distance between the heater of the non-combustible aerosol provision device and the first tubular body is at least about 3 mm. A system and a method of manufacture are also described.

(30) **Foreign Application Priority Data**

Dec. 20, 2019 (GB) 1919064.4

Publication Classification

(51) **Int. Cl.**

A24D 1/20 (2006.01)

A24D 1/04 (2006.01)

A24D 3/17 (2006.01)

A24D 3/04 (2006.01)

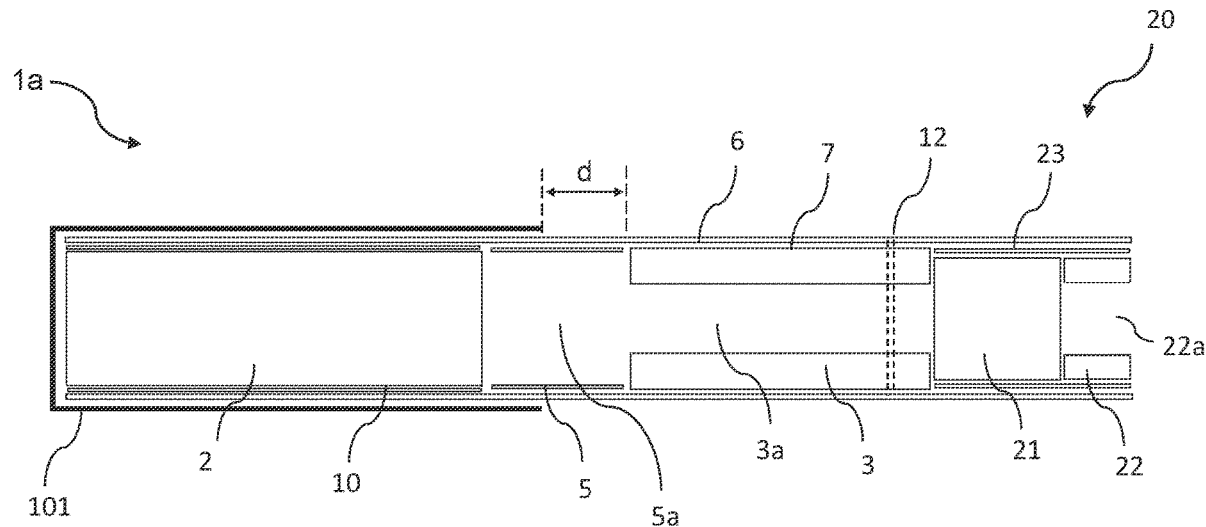

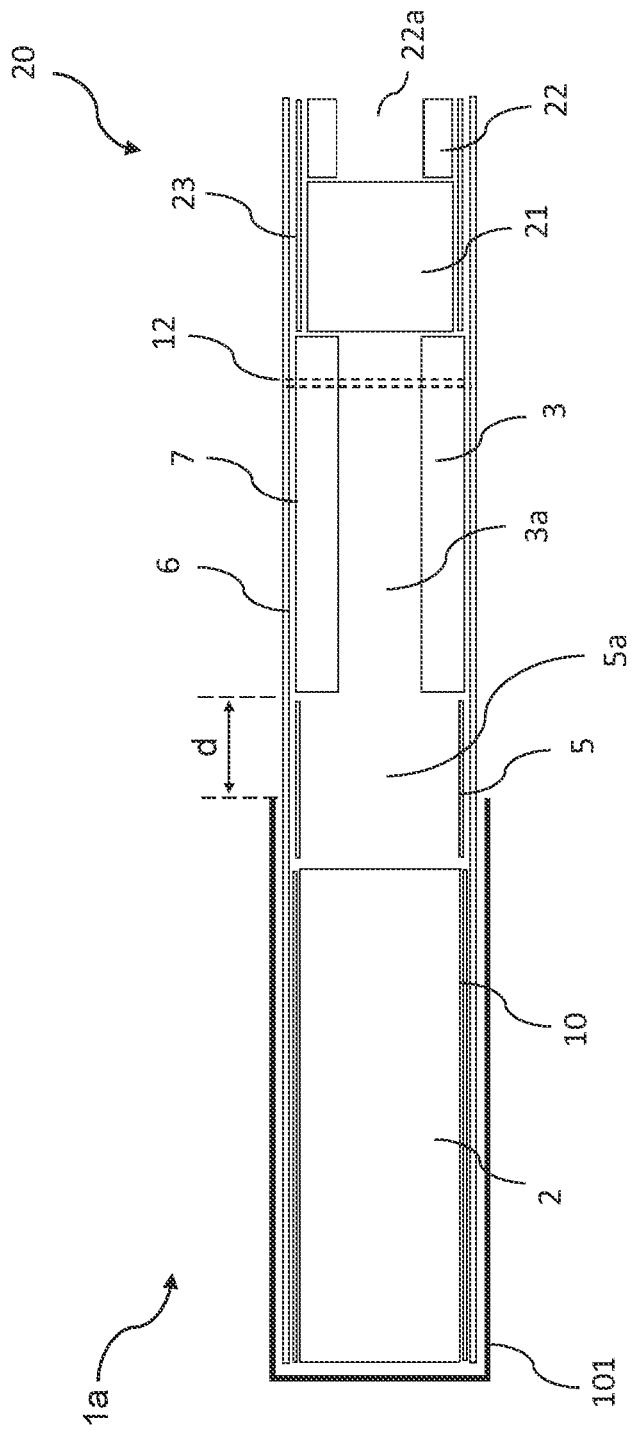

Figure 1

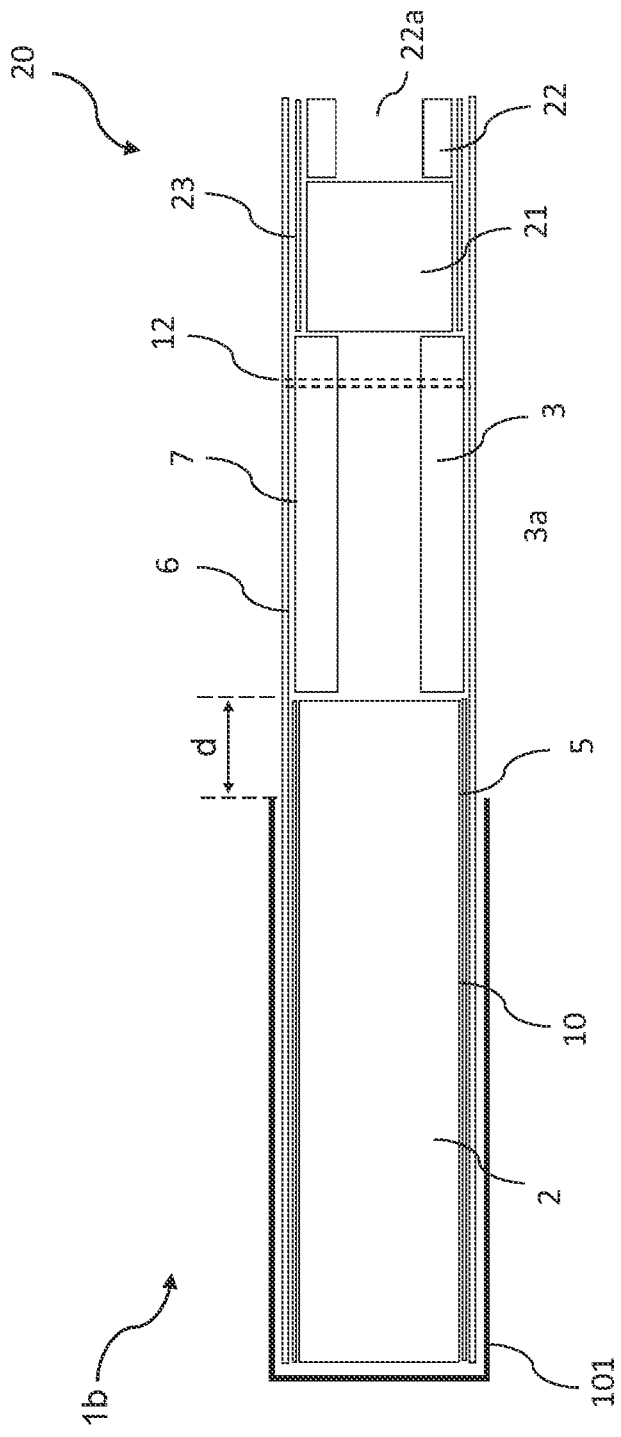

Figure 2

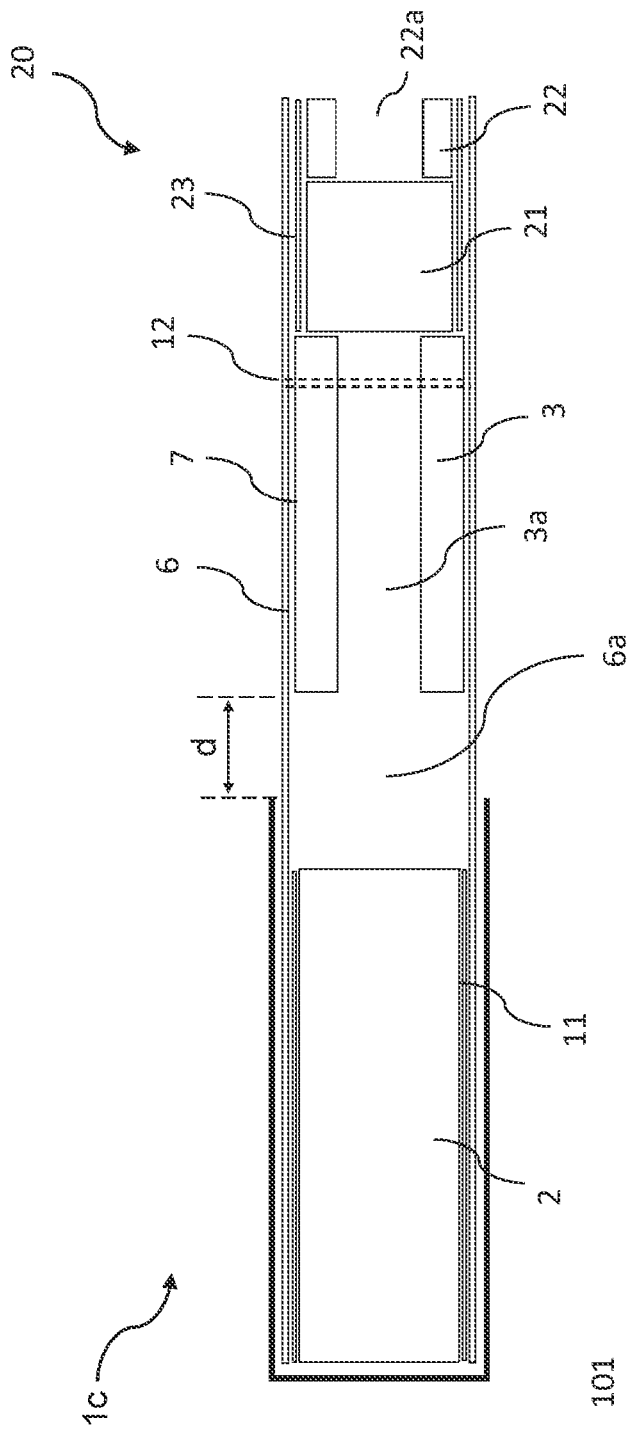

Figure 3

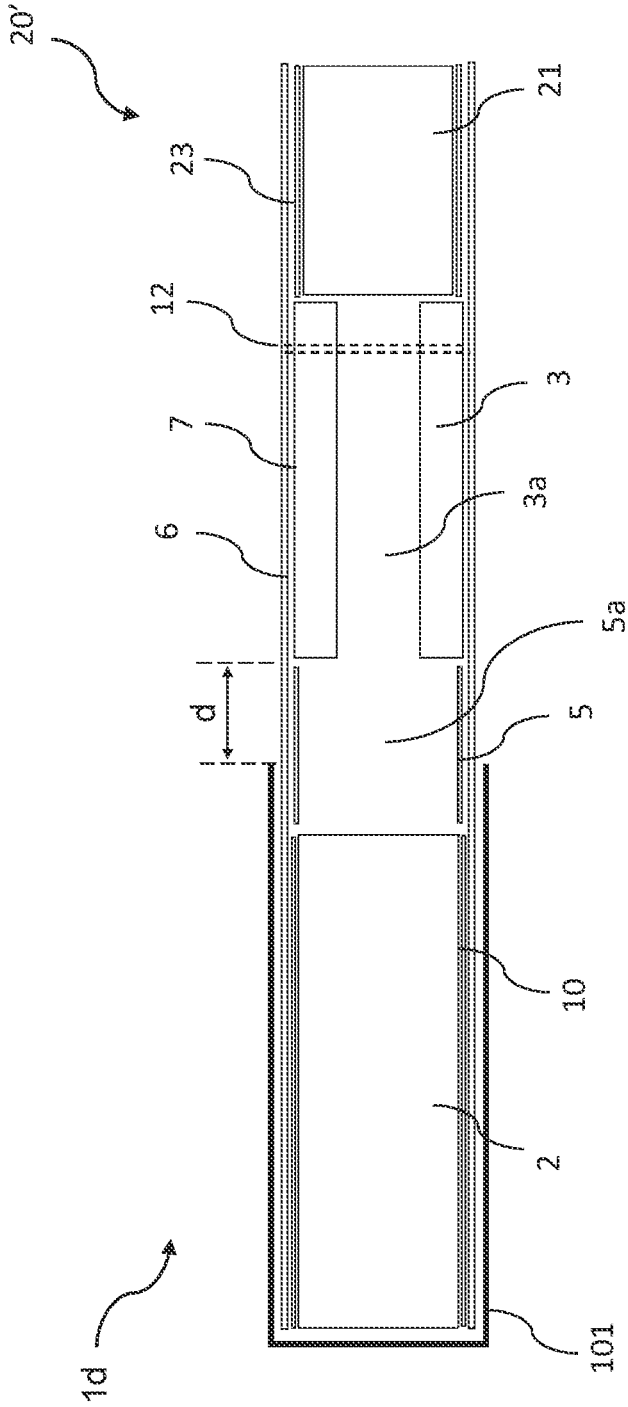

Figure 4

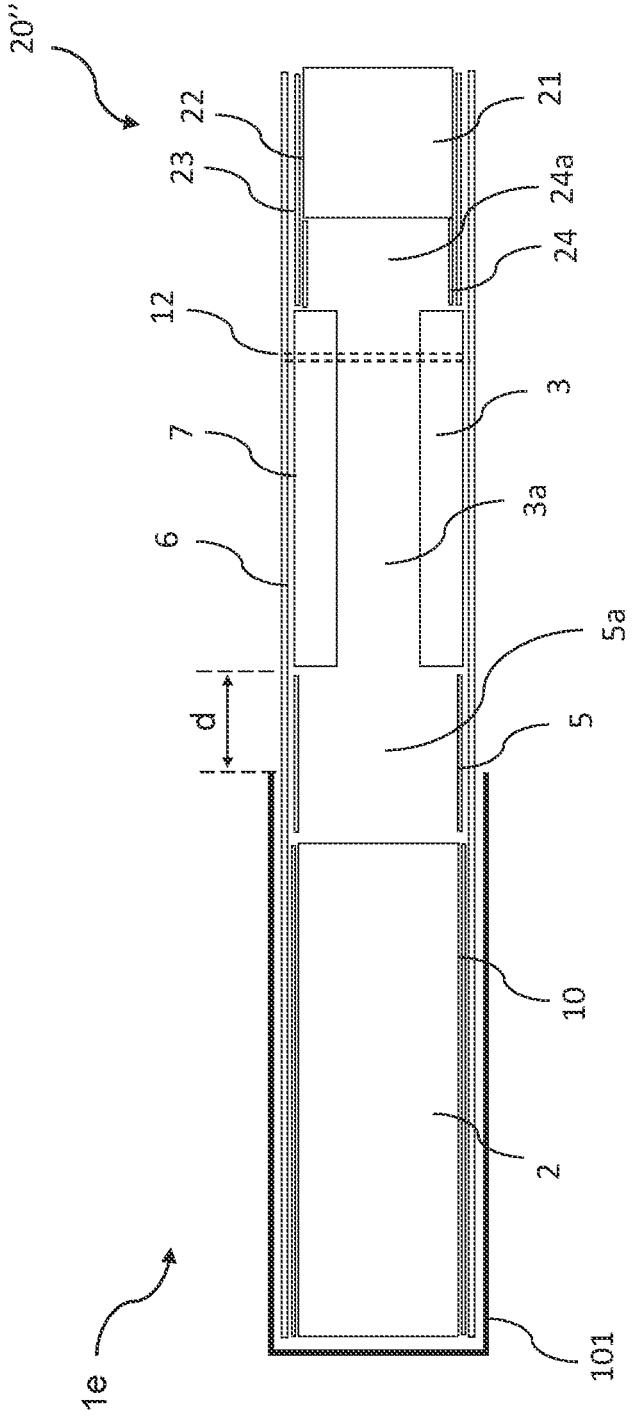

Figure 4a

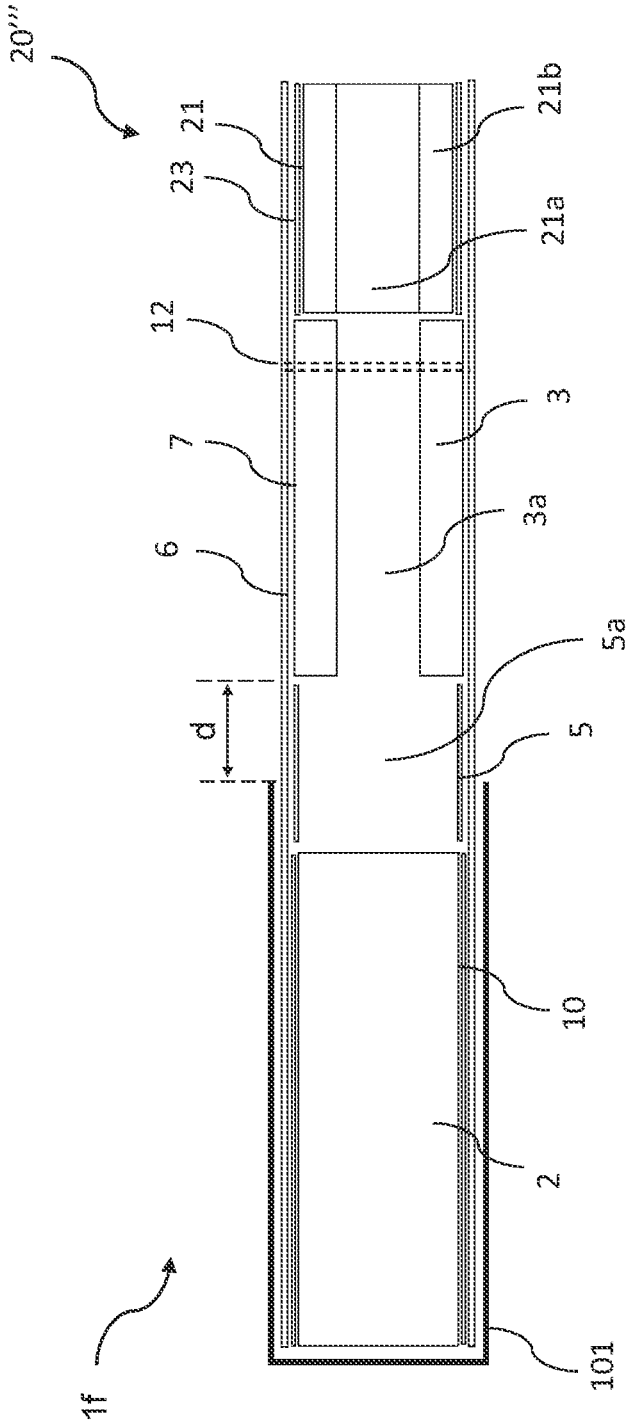

Figure 4b

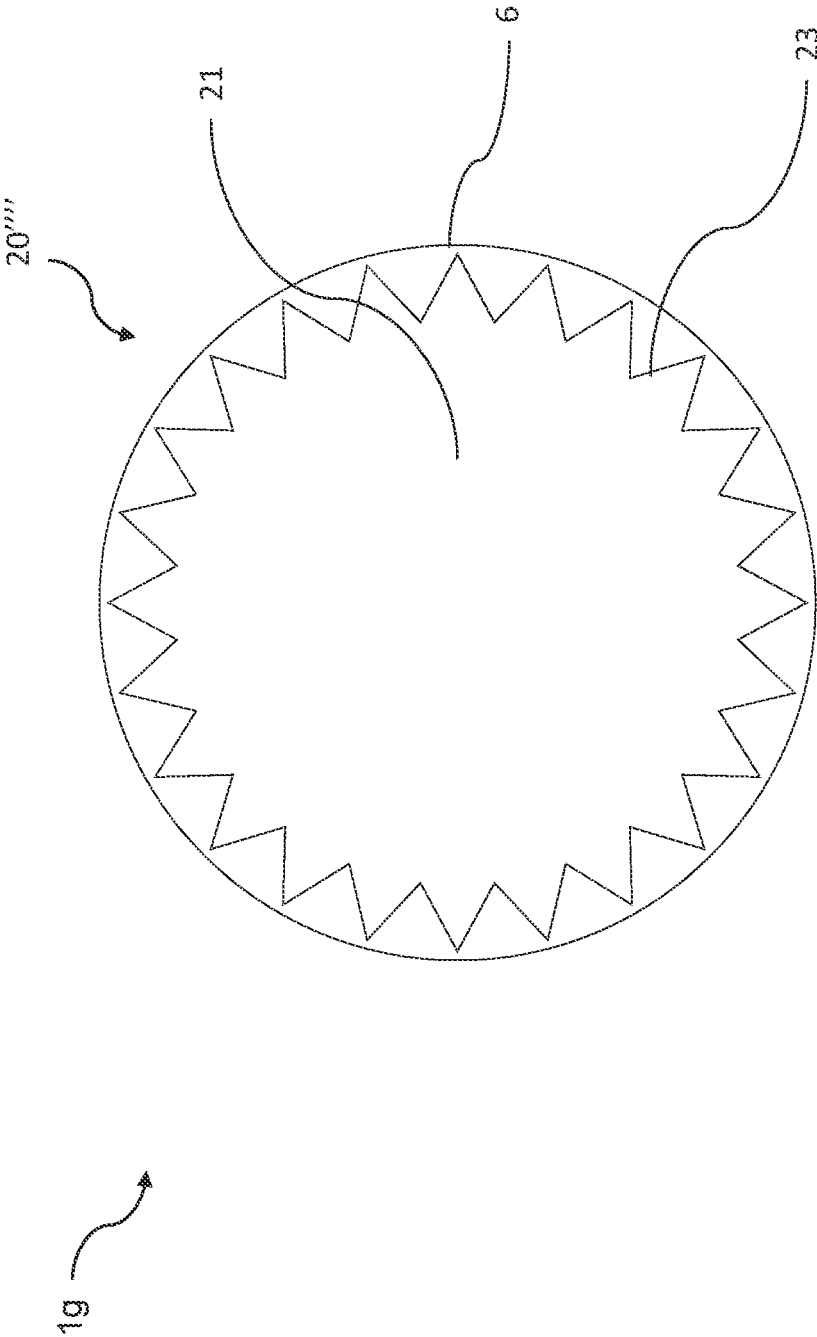

Figure 5

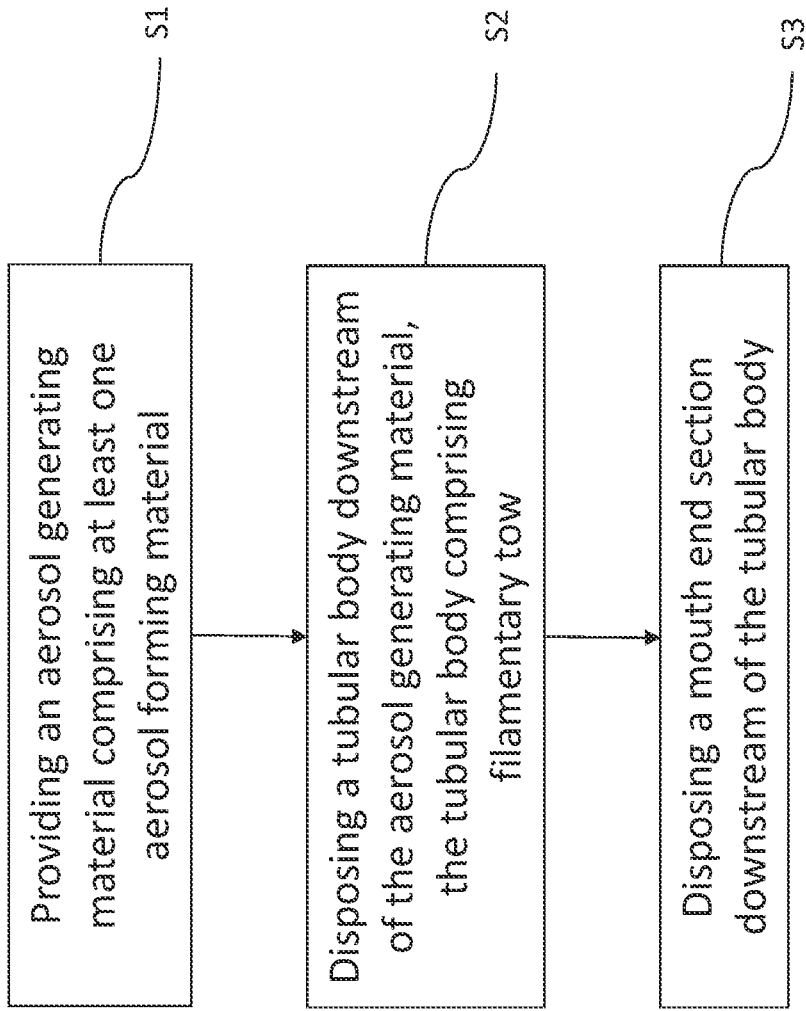

Figure 6

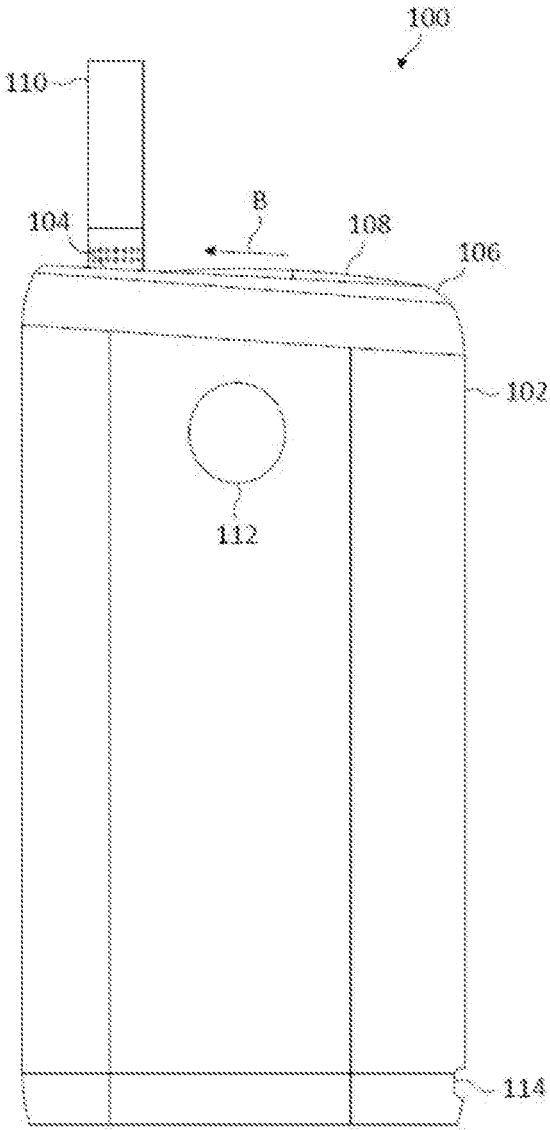

Figure 7

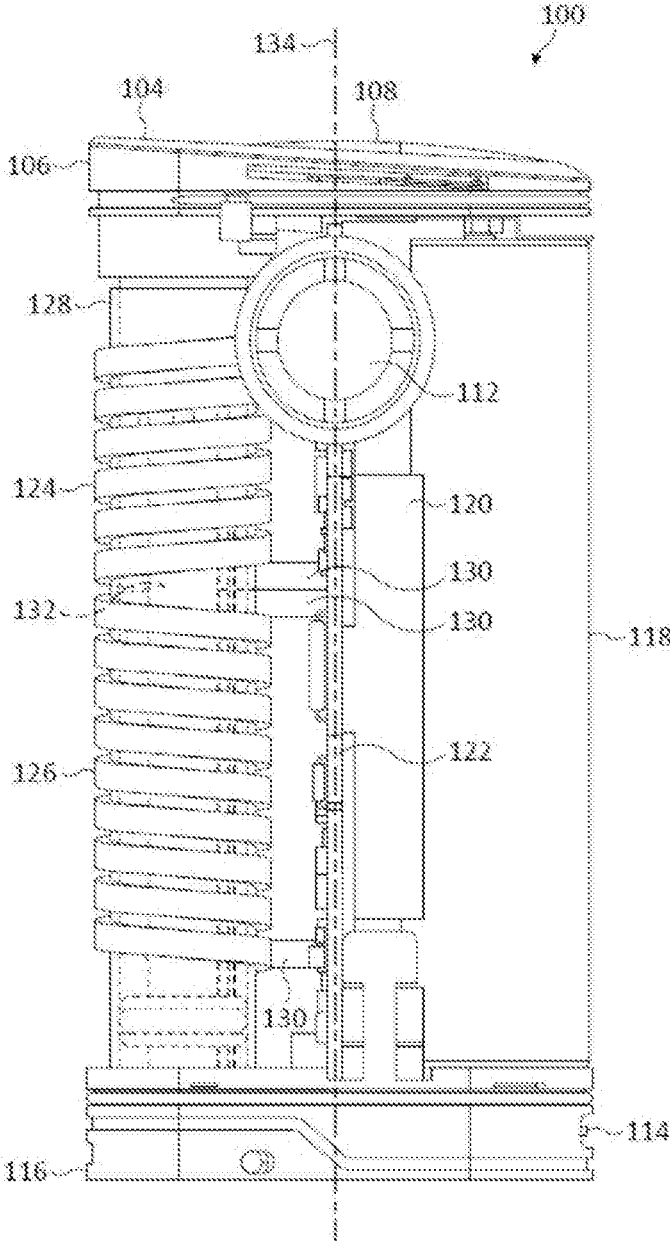

Figure 8

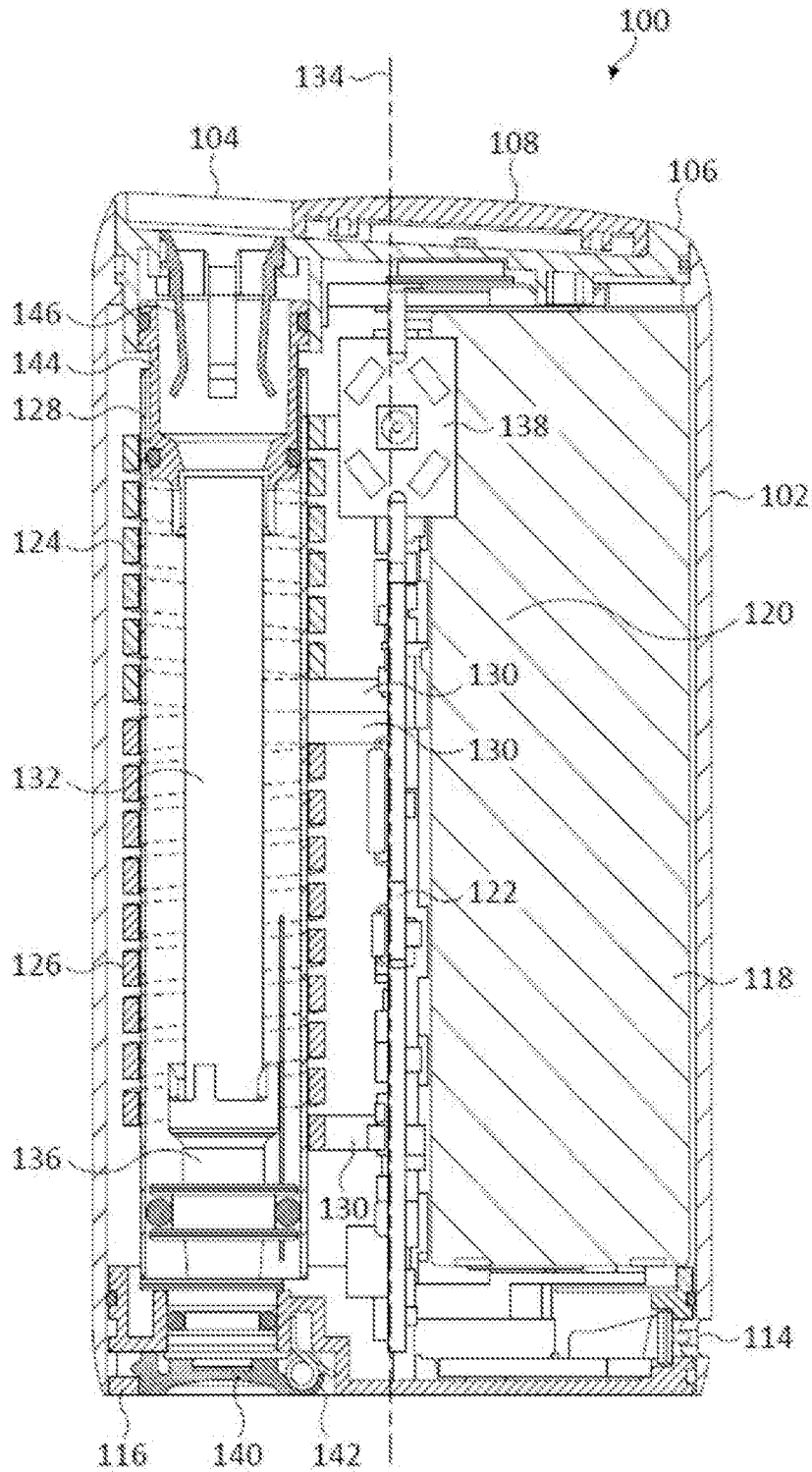

Figure 9

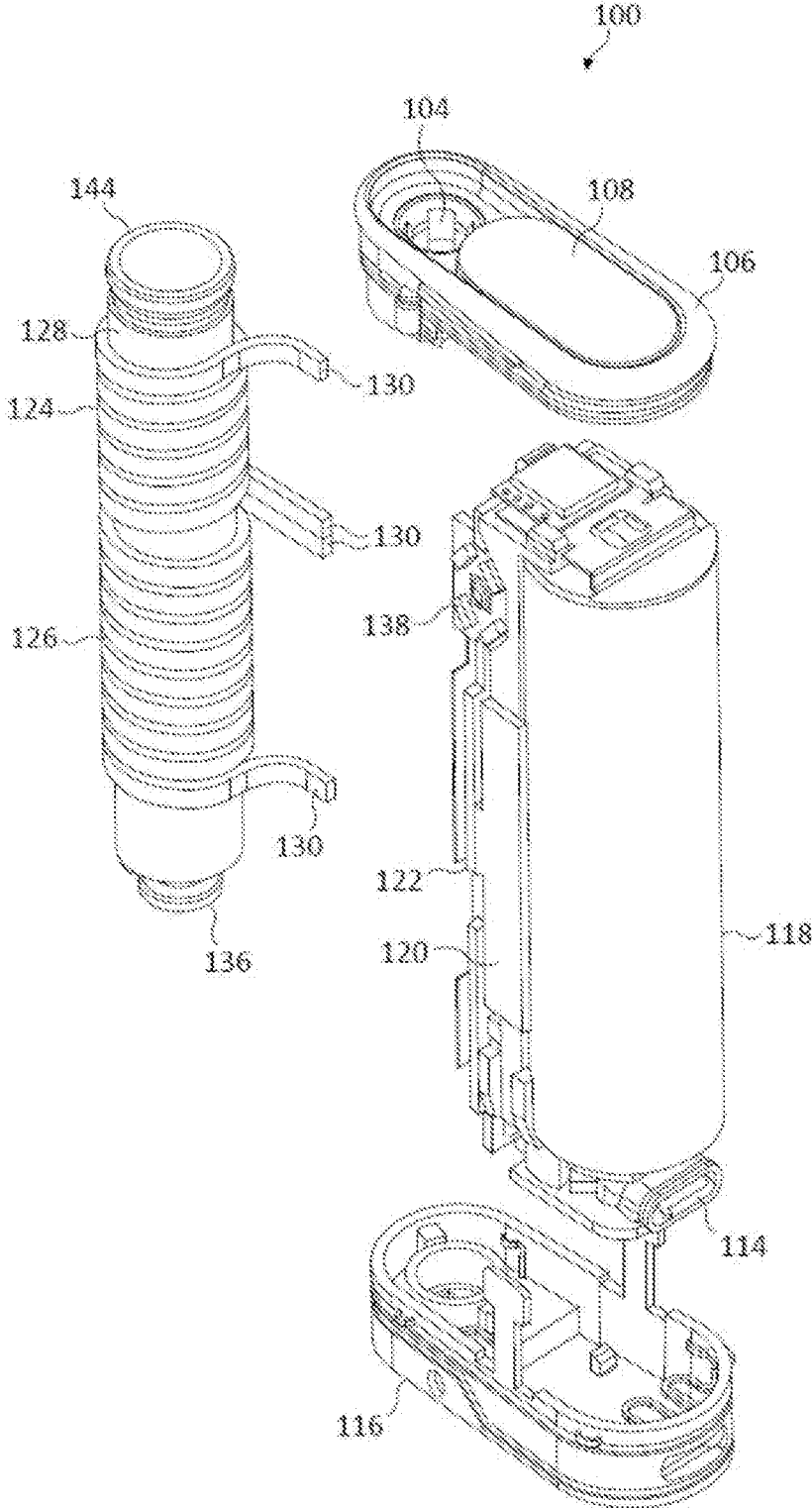

Figure 10

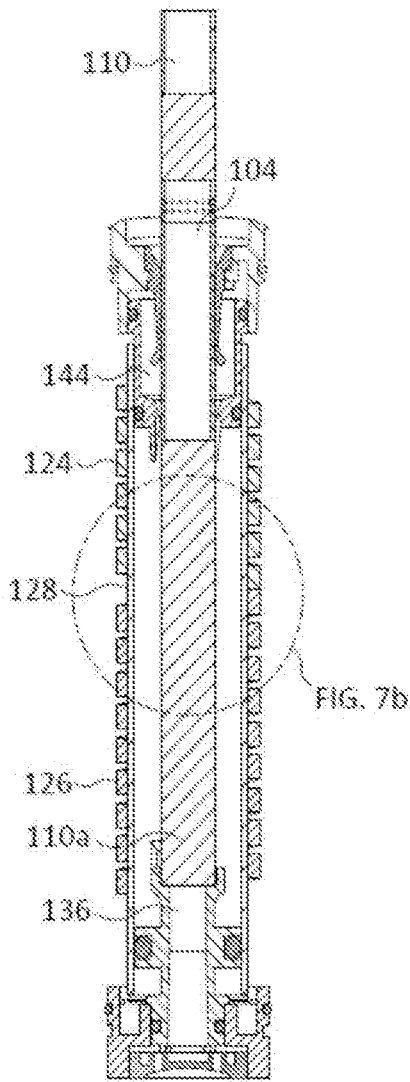

Figure 11A

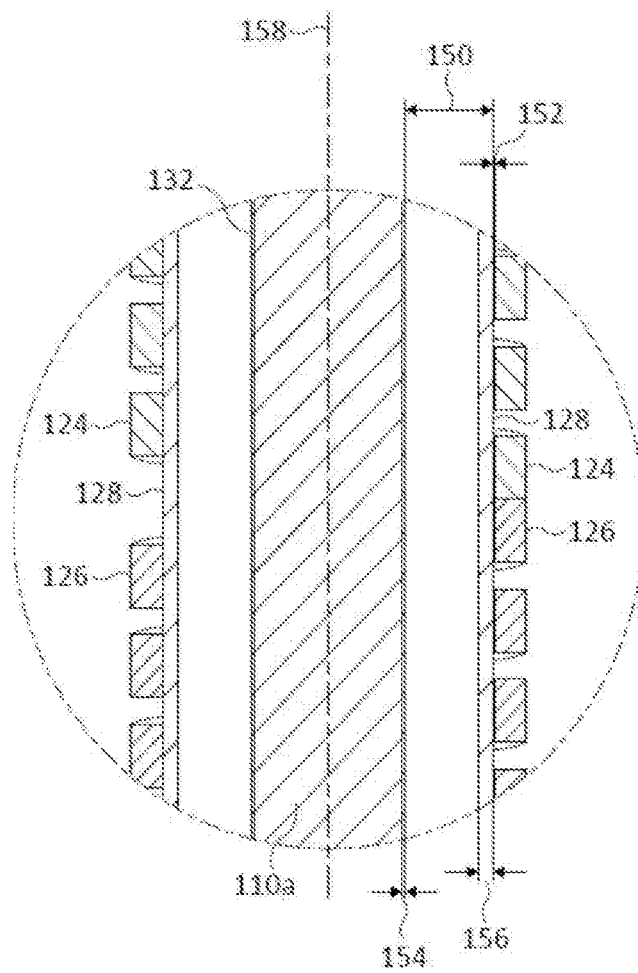

Figure 11B

ARTICLE FOR USE IN AN AEROSOL PROVISION SYSTEM

PRIORITY CLAIM

[0001] The present application is a National Phase entry of PCT Application No. PCT/GB2020/053299, filed Dec. 18, 2020, which claims priority from GB Application No. 1919064.4, filed Dec. 20, 2019, each of which is hereby fully incorporated herein by reference.

TECHNICAL FIELD

[0002] The following relates to an article for use in a non-combustible aerosol provision system, a non-combustible aerosol provision system including an article and a method of manufacturing an article for use with a non-combustible aerosol provision device.

BACKGROUND

[0003] Certain tobacco industry products produce an aerosol during use, which is inhaled by a user. For example, tobacco heating devices heat an aerosol generating substrate such as tobacco to form an aerosol by heating, but not burning, the substrate. Such tobacco industry products commonly include mouthpieces through which the aerosol passes to reach the user's mouth.

SUMMARY

[0004] In some embodiments described herein, in a first aspect there is provided an article for use with a non-combustible aerosol provision device comprising a heater, the article comprising:

[0005] an aerosol generating material comprising at least one aerosol forming material; and

[0006] a first tubular body disposed downstream of the aerosol generating material, the first tubular body comprising filamentary tow; and

[0007] a mouth end section disposed downstream of the first tubular body,

[0008] wherein the article is configured such that when the article is inserted into the non-combustible aerosol provision device, the minimum distance between the heater of the non-combustible aerosol provision device and the first tubular body is at least about 3 mm.

[0009] In some embodiments described herein, in a second aspect there is provided a system comprising:

[0010] a non-combustible aerosol provision device comprising a heater; and

[0011] an article according to any one of claims 1 to 22.

[0012] In some embodiments described herein, in a third aspect there is provided method of manufacturing an article for use with a non-combustible aerosol provision device comprising a heater, the method comprising:

[0013] providing an aerosol generating material comprising at least one aerosol forming material; and

[0014] disposing a tubular body downstream of the aerosol generating material, the tubular body comprising filamentary tow;

[0015] disposing a mouth end section downstream of the tubular body; and

[0016] wherein the article is configured such that when the article is inserted into the non-combustible aerosol provision device, the minimum distance between the

heater of the non-combustible aerosol provision device and the tubular body is at least 3 mm.

BRIEF DESCRIPTION OF THE DRAWINGS

[0017] Embodiments will now be described, by way of example only, with reference to the accompanying drawings, in which:

[0018] FIG. 1 illustrates an article for use in a non-combustible aerosol provision system, the article including a mouth end section comprising a first hollow tubular body, a second hollow tubular body, and a cylindrical body disposed between the first and second hollow tubular bodies;

[0019] FIG. 2 illustrates an article for use in a non-combustible aerosol provision system, the article including an aerosol generating section configured to extend away from a heater of the non-combustible aerosol provision system by a minimum distance;

[0020] FIG. 3 illustrates an article for use in a non-combustible aerosol provision system, the article including a cavity downstream of the aerosol generating material formed by a wrapper;

[0021] FIG. 4 illustrates an article for use in a non-combustible aerosol provision system, the article including a first alternative mouth end section;

[0022] FIG. 4a illustrates an article for use in a non-combustible aerosol provision system, the article including a second alternative mouth end section;

[0023] FIG. 4b illustrates an article for use in a non-combustible aerosol provision system, the article including a third alternative mouth end section;

[0024] FIG. 5 illustrates an article for use in a non-combustible aerosol provision system, the article including a mouth end section comprising a body of material with a non-circular cross section;

[0025] FIG. 6 schematically illustrates the steps of a method of manufacturing an article;

[0026] FIG. 7 is a perspective illustration of a non-combustible aerosol provision device for generating aerosol from the aerosol generating material of the articles of FIGS. 1, 2, 3, 4, 4a, 4b and 5;

[0027] FIG. 8 illustrates the device of FIG. 7 with the outer cover removed and without an article present;

[0028] FIG. 9 is a side view of the device of FIG. 7 in partial cross-section;

[0029] FIG. 10 is an exploded view of the device of FIG. 7, with the outer cover omitted;

[0030] FIG. 11A is a cross sectional view of a portion of the device of FIG. 7; and

[0031] FIG. 11B is a close-up illustration of a region of the device of FIG. 11A.

DETAILED DESCRIPTION OF THE DRAWINGS

[0032] As used herein, the term "delivery system" is intended to encompass systems that deliver at least one substance to a user, and includes:

[0033] combustible aerosol provision systems, such as cigarettes, cigarillos, cigars, and tobacco for pipes or for roll-your-own or for make-your-own cigarettes (whether based on tobacco, tobacco derivatives, expanded tobacco, reconstituted tobacco, tobacco substitutes or other smokable material);

[0034] non-combustible aerosol provision systems that release compounds from an aerosol-generating material

without combusting the aerosol-generating material, such as electronic cigarettes, tobacco heating products, and hybrid systems to generate aerosol using a combination of aerosol-generating materials; and

[0035] aerosol-free delivery systems that deliver the at least one substance to a user orally, nasally, transdermally or in another way without forming an aerosol, including but not limited to, lozenges, gums, patches, articles comprising inhalable powders, and oral products such as oral tobacco which includes snus or moist snuff, wherein the at least one substance may or may not comprise nicotine.

[0036] According to the present disclosure, a “combustible” aerosol provision system is one where a constituent aerosol-generating material of the aerosol provision system (or component thereof) is combusted or burned during use in order to facilitate delivery of at least one substance to a user.

[0037] According to the present disclosure, a “non-combustible” aerosol provision system is one where a constituent aerosol-generating material of the aerosol provision system (or component thereof) is not combusted or burned in order to facilitate delivery of at least one substance to a user.

[0038] In embodiments described herein, the delivery system is a non-combustible aerosol provision system, such as a powered non-combustible aerosol provision system.

[0039] In some embodiments, the non-combustible aerosol provision system is an electronic cigarette, also known as a vaping device or electronic nicotine delivery system (END), although it is noted that the presence of nicotine in the aerosol-generating material is not a requirement.

[0040] In some embodiments, the non-combustible aerosol provision system is an aerosol-generating material heating system, also known as a heat-not-burn system. An example of such a system is a tobacco heating system.

[0041] In one embodiment, the non-combustible aerosol provision system is a hybrid system to generate aerosol using a combination of aerosolizable materials, one or a plurality of which may be heated. Each of the aerosolizable materials may be, for example, in the form of a solid, liquid or gel and may or may not contain nicotine. In one embodiment, the hybrid system comprises a liquid or gel aerosolizable material and a solid aerosolizable material. The solid aerosolizable material may comprise, for example, tobacco or a non-tobacco product.

[0042] Typically, the non-combustible aerosol provision system may comprise a non-combustible aerosol provision device and a consumable for use with the non-combustible aerosol provision device.

[0043] In some embodiments, the disclosure relates to consumables comprising aerosol-generating material and configured to be used with non-combustible aerosol provision devices. These consumables are sometimes referred to as articles throughout the disclosure.

[0044] A consumable is an article comprising or consisting of aerosol-generating material, part or all of which is intended to be consumed during use by a user. A consumable may comprise one or more other components, such as an aerosol-generating material storage area, an aerosol-generating material transfer component, an aerosol generation area, a housing, a wrapper, a mouthpiece, a filter and/or an aerosol-modifying agent. A consumable may also comprise an aerosol generator, such as a heater, that emits heat to cause the aerosol-generating material to generate aerosol in

use. The heater may, for example, comprise combustible material, a material heatable by electrical conduction, or a susceptor.

[0045] In some embodiments, the non-combustible aerosol provision system, such as a non-combustible aerosol provision device thereof, may comprise a power source and a controller. The power source may, for example, be an electric power source or an exothermic power source. In some embodiments, the exothermic power source comprises a carbon substrate which may be energized so as to distribute power in the form of heat to an aerosol-generating material or to a heat transfer material in proximity to the exothermic power source.

[0046] In some embodiments, the non-combustible aerosol provision system may comprise an area for receiving the consumable, an aerosol generator, an aerosol generation area, a housing, a mouthpiece, a filter and/or an aerosol-modifying agent.

[0047] In some embodiments, the consumable for use with the non-combustible aerosol provision device may comprise aerosol-generating material, an aerosol-generating material storage area, an aerosol-generating material transfer component, an aerosol generator, an aerosol generation area, a housing, a wrapper, a filter, a mouthpiece, and/or an aerosol-modifying agent.

[0048] In some embodiments, the substance to be delivered may be an aerosol-generating material or a material that is not intended to be aerosolized. As appropriate, either material may comprise one or more active constituents, one or more flavors, one or more aerosol-former materials, and/or one or more other functional materials.

[0049] An aerosol generator is an apparatus configured to cause aerosol to be generated from the aerosol-generating material. In some embodiments, the aerosol generator is a heater configured to subject the aerosol-generating material to heat energy, so as to release one or more volatiles from the aerosol-generating material to form an aerosol. In some embodiments, the aerosol generator is configured to cause an aerosol to be generated from the aerosol-generating material without heating. For example, the aerosol generator may be configured to subject the aerosol-generating material to one or more of vibration, increased pressure, or electrostatic energy.

[0050] Aerosol-generating material is a material that is capable of generating aerosol, for example when heated, irradiated or energized in any other way. Aerosol-generating material may, for example, be in the form of a solid, liquid or gel which may or may not contain an active substance and/or flavorants. In some embodiments, the aerosol-generating material may comprise an “amorphous solid”, which may alternatively be referred to as a “monolithic solid” (i.e. non-fibrous). In some embodiments, the amorphous solid may be a dried gel. The amorphous solid is a solid material that may retain some fluid, such as liquid, within it. In some embodiments, the aerosol-generating material may for example comprise from about 50 wt %, 60 wt % or 70 wt % of amorphous solid, to about 90 wt %, 95 wt % or 100 wt % of amorphous solid.

[0051] The aerosol-generating material may comprise one or more active substances and/or flavors, one or more aerosol-former materials, and optionally one or more other functional material.

[0052] The aerosol-former material may comprise one or more constituents capable of forming an aerosol. In some

embodiments, the aerosol-former material may comprise one or more of glycerine, glycerol, propylene glycol, diethylene glycol, triethylene glycol, tetraethylene glycol, 1,3-butylene glycol, erythritol, meso-Erythritol, ethyl vanillate, ethyl laurate, a diethyl suberate, triethyl citrate, triacetin, a diacetin mixture, benzyl benzoate, benzyl phenyl acetate, tributyrin, lauryl acetate, lauric acid, myristic acid, and propylene carbonate.

[0053] The one or more other functional materials may comprise one or more of pH regulators, coloring agents, preservatives, binders, fillers, stabilizers, and/or antioxidants.

[0054] The material may be present on or in a support, to form a substrate. The support may, for example, be or comprise paper, card, paperboard, cardboard, reconstituted material, a plastics material, a ceramic material, a composite material, glass, a metal, or a metal alloy. In some embodiments, the support comprises a susceptor. In some embodiments, the susceptor is embedded within the material. In some alternative embodiments, the susceptor is on one or either side of the material.

[0055] An aerosol-modifying agent is a substance, typically located downstream of the aerosol generation area, that is configured to modify the aerosol generated, for example by changing the taste, flavor, acidity or another characteristic of the aerosol. The aerosol-modifying agent may be provided in an aerosol-modifying agent release component, that is operable to selectively release the aerosol-modifying agent.

[0056] The aerosol-modifying agent may, for example, be an additive or a sorbent. The aerosol-modifying agent may, for example, comprise one or more of a flavorant, a colorant, water, and a carbon adsorbent. The aerosol-modifying agent may, for example, be a solid, a liquid, or a gel. The aerosol-modifying agent may be in powder, thread or granule form. The aerosol-modifying agent may be free from filtration material.

[0057] A susceptor is a material that is heatable by penetration with a varying magnetic field, such as an alternating magnetic field. The susceptor may be an electrically-conductive material, so that penetration thereof with a varying magnetic field causes induction heating of the heating material. The heating material may be magnetic material, so that penetration thereof with a varying magnetic field causes magnetic hysteresis heating of the heating material. The susceptor may be both electrically-conductive and magnetic, so that the susceptor is heatable by both heating mechanisms. The device that is configured to generate the varying magnetic field is referred to as a magnetic field generator, herein.

[0058] Induction heating is a process in which an electrically-conductive object is heated by penetrating the object with a varying magnetic field. The process is described by Faraday's law of induction and Ohm's law. An induction heater may comprise an electromagnet and a device for passing a varying electrical current, such as an alternating current, through the electromagnet. When the electromagnet and the object to be heated are suitably relatively positioned so that the resultant varying magnetic field produced by the electromagnet penetrates the object, one or more eddy currents are generated inside the object. The object has a resistance to the flow of electrical currents. Therefore, when such eddy currents are generated in the object, their flow against the electrical resistance of the object causes the

object to be heated. This process is called Joule, ohmic, or resistive heating. An object that is capable of being inductively heated is known as a susceptor.

[0059] In one embodiment, the susceptor is in the form of a closed circuit. It has been found that, when the susceptor is in the form of a closed circuit, magnetic coupling between the susceptor and the electromagnet in use is enhanced, which results in greater or improved Joule heating.

[0060] Magnetic hysteresis heating is a process in which an object made of a magnetic material is heated by penetrating the object with a varying magnetic field. A magnetic material can be considered to comprise many atomic-scale magnets, or magnetic dipoles. When a magnetic field penetrates such material, the magnetic dipoles align with the magnetic field. Therefore, when a varying magnetic field, such as an alternating magnetic field, for example as produced by an electromagnet, penetrates the magnetic material, the orientation of the magnetic dipoles changes with the varying applied magnetic field. Such magnetic dipole reorientation causes heat to be generated in the magnetic material.

[0061] When an object is both electrically-conductive and magnetic, penetrating the object with a varying magnetic field can cause both Joule heating and magnetic hysteresis heating in the object. Moreover, the use of magnetic material can strengthen the magnetic field, which can intensify the Joule heating.

[0062] In each of the above processes, as heat is generated inside the object itself, rather than by an external heat source by heat conduction, a rapid temperature rise in the object and more uniform heat distribution can be achieved, particularly through selection of suitable object material and geometry, and suitable varying magnetic field magnitude and orientation relative to the object.

[0063] Moreover, as induction heating and magnetic hysteresis heating do not require a physical connection to be provided between the source of the varying magnetic field and the object, design freedom and control over the heating profile may be greater, and cost may be lower.

[0064] Articles, for instance those in the shape of rods, are often named according to the product length: "regular" (typically in the range 68-75 mm, e.g. from about 68 mm to about 72 mm), "short" or "mini" (68 mm or less), "king-size" (typically in the range 75-91 mm, e.g. from about 79 mm to about 88 mm), "long" or "super-king" (typically in the range 91-105 mm, e.g. from about 94 mm to about 101 mm) and "ultra-long" (typically in the range from about 110 mm to about 121 mm).

[0065] They are also named according to the product circumference: "regular" (about 23-25 mm), "wide" (greater than 25 mm), "slim" (about 22-23 mm), "demi-slim" (about 19-22 mm), "super-slim" (about 16-19 mm), and "micro-slim" (less than about 16 mm).

[0066] Accordingly, an article in a king-size, super-slim format will, for example, have a length of about 83 mm and a circumference of about 17 mm.

[0067] Each format may be produced with mouthpieces of different lengths. The mouthpiece length will be from about 30 mm to 50 mm. A tipping paper connects the mouthpiece to the aerosol generating material and will usually have a greater length than the mouthpiece, for example from 3 to 10 mm longer, such that the tipping paper covers the mouth-

piece and overlaps the aerosol generating material, for instance in the form of a rod of substrate material, to connect the mouthpiece to the rod.

[0068] Articles and their aerosol generating materials and mouthpieces described herein can be made in, but are not limited to, any of the above formats.

[0069] The terms ‘upstream’ and ‘downstream’ used herein are relative terms defined in relation to the direction of mainstream aerosol drawn through an article or device in use.

[0070] The filamentary tow or filter material described herein can comprise cellulose acetate fibertow. The filamentary tow can also be formed using other materials used to form fibers, such as polyvinyl alcohol (PVOH), polylactic acid (PLA), polycaprolactone (PCL), poly(1-4 butanediol succinate) (PBS), poly(butylene adipate-co-terephthalate) (PBAT), starch based materials, cotton, aliphatic polyester materials and polysaccharide polymers or a combination thereof. The filamentary tow may be plasticized with a suitable plasticizer for the tow, such as triacetin where the material is cellulose acetate tow, or the tow may be non-plasticized. The tow can have any suitable specification, such as fibers having a cross section which is ‘Y’ shaped, ‘X’ shaped or ‘O’ shaped. The fibers of the tow may have filamentary denier values between 2.5 and 15 denier per filament, for example between 8.0 and 11.0 denier per filament and total denier values of 5,000 to 50,000, for example between 10,000 and 40,000. When viewed in cross section, the fibers may have an isoperimetric ratio L^2/A of 25 or less, preferably 20 or less, and more preferably 15 or less, where L is the length of the perimeter of the cross section and A is the area of the cross section. Filter material described herein also includes cellulose-based materials such as paper. Such materials may have a relatively low density, such as between about 0.1 and about 0.45 grams per cubic centimeter, to allow air and/or aerosol to pass through the material. Although described as filter materials, such materials may have a primary purpose, such as increasing the resistance to draw of a component, that is not related to filtration as such.

[0071] As used herein, the term “tobacco material” refers to any material comprising tobacco or derivatives or substitutes thereof. The term “tobacco material” may include one or more of tobacco, tobacco derivatives, expanded tobacco, reconstituted tobacco or tobacco substitutes. The tobacco material may comprise one or more of ground tobacco, tobacco fiber, cut tobacco, extruded tobacco, tobacco stem, tobacco lamina, reconstituted tobacco and/or tobacco extract.

[0072] In some embodiments, the substance to be delivered comprises an active substance.

[0073] The active substance as used herein may be a physiologically active material, which is a material intended to achieve or enhance a physiological response. The active substance may for example be selected from nutraceuticals, nootropics, psychoactives. The active substance may be naturally occurring or synthetically obtained. The active substance may comprise for example nicotine, caffeine, taurine, theine, vitamins such as B6 or B12 or C, melatonin, cannabinoids, or constituents, derivatives, or combinations thereof. The active substance may comprise one or more constituents, derivatives or extracts of tobacco, *cannabis* or another botanical.

[0074] In some embodiments, the active substance comprises nicotine. In some embodiments, the active substance comprises caffeine, melatonin or vitamin B12.

[0075] As noted herein, the active substance may comprise or be derived from one or more botanicals or constituents, derivatives or extracts thereof. As used herein, the term “botanical” includes any material derived from plants including, but not limited to, extracts, leaves, bark, fibers, stems, roots, seeds, flowers, fruits, pollen, husk, shells or the like. Alternatively, the material may comprise an active compound naturally existing in a botanical, obtained synthetically. The material may be in the form of liquid, gas, solid, powder, dust, crushed particles, granules, pellets, shreds, strips, sheets, or the like. Example botanicals are tobacco, *eucalyptus*, star anise, hemp, cocoa, *cannabis*, fennel, lemongrass, peppermint, spearmint, rooibos, chamomile, flax, ginger, *Ginkgo biloba*, hazel, hibiscus, laurel, licorice (liquorice), matcha, mate, orange skin, *papaya*, rose, sage, tea such as green tea or black tea, thyme, clove, cinnamon, coffee, aniseed (anise), basil, bay leaves, cardamom, coriander, cumin, nutmeg, oregano, paprika, rosemary, saffron, lavender, lemon peel, mint, juniper, elderflower, vanilla, wintergreen, beefsteak plant, *curcuma*, turmeric, sandalwood, cilantro, bergamot, orange blossom, myrtle, cassis, valerian, pimento, mace, damien, marjoram, olive, lemon balm, lemon basil, chive, *carvi*, *verbena*, tarragon, geranium, mulberry, *ginseng*, theanine, theacrine, maca, ashwagandha, damiana, guarana, chlorophyll, baobab or any combination thereof. The mint may be chosen from the following mint varieties: *Mentha Arvensis*, *Mentha c.v.*, *Mentha niliaca*, *Mentha piperita*, *Mentha piperita citrata c.v.*, *Mentha piperita c.v.*, *Mentha spicata crispata*, *Mentha cardifolia*, *Mentha longifolia*, *Mentha suaveolens variegata*, *Mentha pulegium*, *Mentha spicata c.v.* and *Mentha suaveolens*

[0076] In some embodiments, the active substance comprises or is derived from one or more botanicals or constituents, derivatives or extracts thereof and the botanical is tobacco.

[0077] In some embodiments, the active substance comprises or derived from one or more botanicals or constituents, derivatives or extracts thereof and the botanical is selected from *eucalyptus*, star anise, cocoa and hemp.

[0078] In some embodiments, the active substance comprises or derived from one or more botanicals or constituents, derivatives or extracts thereof and the botanical is selected from rooibos and fennel.

[0079] In some embodiments, the substance to be delivered comprises a flavor.

[0080] As used herein, the terms “flavor” and “flavorant” refer to materials which, where local regulations permit, may be used to create a desired taste, aroma or other somatosensorial sensation in a product for adult consumers. They may include naturally occurring flavor materials, botanicals, extracts of botanicals, synthetically obtained materials, or combinations thereof (e.g., tobacco, *cannabis*, licorice (liquorice), *hydrangea*, eugenol, Japanese white bark *magnolia* leaf, chamomile, fenugreek, clove, maple, matcha, menthol, Japanese mint, aniseed (anise), cinnamon, turmeric, Indian spices, Asian spices, herb, wintergreen, cherry, berry, red berry, cranberry, peach, apple, orange, mango, clementine, lemon, lime, tropical fruit, *papaya*, rhubarb, grape, durian, dragon fruit, cucumber, blueberry, mulberry, citrus fruits, Drambuie, bourbon, scotch, whiskey,

gin, tequila, rum, spearmint, peppermint, lavender, aloe vera, cardamom, celery, cascarrilla, nutmeg, sandalwood, bergamot, geranium, khat, naswar, *betel*, shisha, pine, honey essence, rose oil, vanilla, lemon oil, orange oil, orange blossom, cherry blossom, *cassia*, caraway, cognac, jasmine, ylang-ylang, sage, fennel, wasabi, piment, ginger, coriander, coffee, hemp, a mint oil from any species of the genus *Mentha*, *eucalyptus*, star anise, cocoa, lemongrass, rooibos, flax, *Ginkgo biloba*, hazel, hibiscus, laurel, mate, orange skin, rose, tea such as green tea or black tea, thyme, juniper, elderflower, basil, bay leaves, cumin, oregano, paprika, rosemary, saffron, lemon peel, mint, beefsteak plant, *curcuma*, cilantro, myrtle, cassis, valerian, pimento, mace, damien, marjoram, olive, lemon balm, lemon basil, chive, *carvi*, *verbena*, tarragon, limonene, thymol, camphene), flavor enhancers, bitterness receptor site blockers, sensorial receptor site activators or stimulators, sugars and/or sugar substitutes (e.g., sucralose, acesulfame potassium, aspartame, saccharine, cyclamates, lactose, sucrose, glucose, fructose, sorbitol, or mannitol), and other additives such as charcoal, chlorophyll, minerals, botanicals, or breath freshening agents. They may be imitation, synthetic or natural ingredients or blends thereof. They may be in any suitable form, for example, liquid such as an oil, solid such as a powder, or gas.

[0081] In some embodiments, the flavor comprises menthol, spearmint and/or peppermint. In some embodiments, the flavor comprises flavor components of cucumber, blueberry, citrus fruits and/or redberry. In some embodiments, the flavor comprises eugenol. In some embodiments, the flavor comprises flavor components extracted from tobacco. In some embodiments, the flavor comprises flavor components extracted from *cannabis*.

[0082] In some embodiments, the flavor may comprise a sensate, which is intended to achieve a somatosensorial sensation, which are usually chemically induced and perceived by the stimulation of the fifth cranial nerve (trigeminal nerve), in addition to or in place of aroma or taste nerves, and these may include agents providing heating, cooling, tingling, numbing effect. A suitable heat effect agent may be, but is not limited to, vanillyl ethyl ether and a suitable cooling agent may be, but not limited to eucalyptol, WS-3.

[0083] In the figures described herein, like reference numerals are used to illustrate equivalent features, articles or components.

[0084] FIGS. 1 to 5 illustrate various articles 1a-1g for use as part of a non-combustible aerosol provision system. The articles can, for instance, be used with a non-combustible aerosol provision device 100 comprising a heater 101, according to embodiments (see FIGS. 7 to 11B). In the present example, and other examples described herein, the article can be a tobacco-heated product consumable.

[0085] Referring to FIG. 1, the article 1a comprises: a rod of aerosol generating material 2 comprising at least one aerosol forming material; a first tubular body 3 disposed downstream of the aerosol generating material 2, the first tubular body 3 comprising filamentary tow; and a mouth end section 20 disposed downstream of the first tubular body 3. The article 1a is configured such that when the article 1a is inserted into the non-combustible aerosol provision device 100, the minimum distance d between the heater 101 of the non-combustible aerosol provision device 100 and the first

tubular body 3 is at least about 3 mm. In the present example, the aerosol generating material is tobacco material as described herein.

[0086] The minimum distance d between the heater 101 of the non-combustible aerosol provision device 100 and the first tubular body prevents heat from the heater 101 damaging the filamentary tow of the first tubular body 3. In particular, the filamentary tow may be cellulose acetate tow stiffened with a plasticizer, as is known in the art. Heat from the heater 101 may cause the first tubular body 3 to shrink. This is avoided by providing a gap between the first tubular body 3 and the heater 101.

[0087] The minimum distance d may be 3 mm upwards. Preferably, the minimum distance d is about 3 mm up to about 18 mm, more preferably between about 3 mm and about 15 mm, such as between about 3 mm and about 12 mm, for instance between about 3 mm and about 10 mm and anything in between. Exemplified minimum distances d include 3 mm, 4 mm, 5 mm, 6 mm, 7 mm, 8 mm, 9 mm and 10 mm.

[0088] The article 1a comprises a mouthpiece section 20 at the mouth end of the article 1a.

[0089] In each embodiment, the article further comprises a wrapper 6 at least partially surrounding the aerosol generating material 2 and the first tubular body 3 to connect the aerosol generating material 2 to the first tubular body 3. The wrapper may extend along the full length of the article 1a to attach the mouth end section 20 also. Although illustrated as extending the full length of the article 1a, the wrapper may alternatively extend only partially along the length of the aerosol generating material 2, for instance extending over the aerosol generating material 2 by between 3 mm and 10 mm. The aerosol generating material may be wrapper in a wrapper 10, also referred herein as an additional wrapper 10.

[0090] The wrapper 6 may be a paper material comprising a citrate, such as sodium nitrate or potassium nitrate. In such examples, the wrapper 6 may have a citrate content of 2% by weight or less, or 1% by weight or less. This reduces charring of the wrapper 6 when the article 1a is heated in the non-combustible aerosol provision device 100.

[0091] The first tubular body 3 is configured to serve as a heat dissipater to reduce the phenomena of ‘hot puff’. ‘Hot puff’ is defined as aerosol delivered to the user at an uncomfortably high temperature. Hot puff may be exacerbated when a user draws aerosol through a heated article 1a at a high rate, reducing the time for heat in the aerosol to be dissipated. When inserted into a non-combustible aerosol provision device 100, the first tubular body 3 separates the mouth end section from the heater 101 to provide space for heat to dissipate before the aerosol reaches the mouth end section 20. Further, it shall be appreciated that heat will be conducted away from the aerosol and into the first tubular body 3 as the aerosol is drawn therethrough. In this way, the first tubular body 3 acts as a heat sink.

[0092] The first tubular body 3 preferably has a wall thickness of at least about 325 μm and up to about 2 mm, preferably between 500 μm and 1.5 mm and more preferably between 750 μm and 1 mm. In the present example, the first tubular body 3 has a wall thickness of about 1 mm. In alternative examples, the wall thickness can be between about 0.5 mm and about 3 mm, for instance between about 1 mm and about 2.5 mm, or about 2 mm. The ‘‘wall thickness’’ of the first tubular body 3 corresponds to the thickness of the wall of the first tubular body 3 in a radial

direction. This may be measured, for example, using a calliper. In some examples, where the wall thickness is non-uniform, the wall thickness is the minimum wall thickness of the tubular body 3.

[0093] In some embodiments, the thickness of the wall of the first tubular body 3 is at least 325 microns and, preferably, at least 400, 500, 600, 700, 800, 900 or 1000 microns. In some embodiments, the thickness of the wall of the first tubular body 3 is at least 1250 or 1500 microns.

[0094] In some embodiments, the thickness of the wall of the first tubular body 3 is less than 2000 microns and, preferably, less than 1500 microns.

[0095] The increased thickness of the wall of the first tubular body 3 means that it has a greater thermal mass, which has been found to help reduce the temperature of the aerosol passing through the first tubular body 3 and reduce the surface temperature of the mouth end section 20 at locations downstream of the first tubular body 3. This is thought to be because the greater thermal mass of the first tubular body 3 allows the first tubular body 3 to absorb more heat from the aerosol in comparison to a first tubular body 3 with a thinner wall thickness. The increased thickness of the first tubular body 3 also channels the aerosol centrally into the mouth end section 20 such that less heat from the aerosol is transferred to the outer portions of the mouth end section 20.

[0096] In some embodiments, the permeability of the material of the wall of the first tubular body 3 is at least 100 Coresta Units and, preferably, at least 500 or 1000 Coresta Units.

[0097] It has been found that the relatively high permeability of the first tubular body 3 increases the amount of heat that is transferred to the first tubular body 3 from the aerosol and thus reduces the temperature of the aerosol. The permeability of the first tubular body 3 has also been found to increase the amount of moisture that is transferred from the aerosol to the first tubular body 3, which has been found to improve the feel of the aerosol in the user's mouth. A high permeability of first tubular body 3 also makes it easier to cut ventilation holes into the first tubular body 3 using a laser, meaning that a lower power of laser can be used.

[0098] The first tubular body 3 may comprise a filamentary tow comprising filaments having a cross-section with an isoperimetric ratio L^2/A of 25 or less, 20 or less or 15 or less, where L is the length of the perimeter of the cross section and A is the area of the cross section. In other words, the filaments may comprise a substantially 'O' shaped cross section, or at least as close as it is possible to achieve. For a given denier per filament, filaments with a substantially 'O' shaped cross section have a lower surface area than other cross sectional shapes, such as 'Y' or 'X' shaped filaments. Therefore, the delivery of aerosol to the user is improved.

[0099] It shall be appreciated that aerosol drawn through the first tubular body 3 passes through both a central cavity 3a in the first tubular body 3 and also partly through the filaments of the first tubular body 3 itself. By providing filaments with a substantially 'o' shaped cross section, a greater proportion of aerosol will pass through the filament of the first tubular body 3 itself, increasing heat transfer to the first tubular body 3 yet further.

[0100] In some embodiments, the aerosol generating material 2 described herein is a first aerosol generating material 2 and the first tubular body 3 may comprise a second aerosol generating material. For example, the second

aerosol generating material may be disposed on an inner surface of the first tubular body 3.

[0101] The second aerosol generating material comprises at least one aerosol former material, and may also comprise at least one aerosol modifying agent, or other sensate material. The aerosol former material and/or aerosol-modifying agent can be any aerosol former material or aerosol modifying agent as described herein, or a combination thereof.

[0102] In use, as the aerosol generated from the first aerosol generating material 2 is drawn through the first tubular body 3, heat from the first aerosol may aerosolize the aerosol forming material of the second aerosol generating material, to form a second aerosol. The second aerosol may comprise a flavorant, which may be additional or complementary to the flavor of the first aerosol.

[0103] Providing a second aerosol generating material on the first tubular body 3 can result in generation of a second aerosol, which boosts or complements the flavor or visual appearance of the first aerosol.

[0104] The article 1a may further comprise at least one ventilation area 12 arranged to allow external air to flow into the article. In the illustrated embodiments, the ventilation area 12 comprises a row of ventilation apertures, or perforations, cut into the wrapper 6 and any other wrappers provided at the location of the ventilation area 12. The ventilation apertures may extend in a line around the circumference of the article 1a. The ventilation area 12 may comprise two or more rows of ventilation apertures. By providing a ventilation area 12, ambient air may be drawn into the article during use to further cool the aerosol.

[0105] In the illustrated embodiments, the at least one ventilation area 12 is arranged to provide external air into the cavity 3a of the first tubular body 3. To achieve this, the one or more rows of ventilation apertures extend around the circumference of the article over the first tubular body 3.

[0106] In one example, the ventilation area 12 comprises first and second parallel rows of perforations formed as laser perforations, at positions 17.925 mm and 18.625 mm respectively from the mouth end. These perforations pass through the wrapper 6, and other wrappers provided around the first tubular body, and through the first tubular body 3. In alternative embodiments, the ventilation can be provided at other locations.

[0107] Alternatively, the ventilation can be provided via a single row of perforations, for instance laser perforations, into the portion of the article 1a in which the first tubular body 3 is located. This has been found to result in improved aerosol formation, which is thought to result from the airflow through the perforations being more uniform than with multiple rows of perforations, for a given ventilation level.

[0108] It shall be appreciated that the exact location of the at least one ventilation area 12 is not essential. In another embodiment, the at least one ventilation area 12 is arranged to provide external air into the aerosol generating material 2. To achieve this, the one or more rows of ventilation apertures extend around the circumference of the article over the rod of aerosol generating material 2.

[0109] The level of ventilation provided by the at least one ventilation area 12 is within the range of 40% to 70% of the volume of aerosol generated by the aerosol generating

material **2** passing through the article **1a**, when the article **1a** is heated in the non-combustible aerosol provision device **100**.

[0110] Aerosol temperature has been found to generally increase with a drop in the ventilation level. However the relationship between aerosol temperature and ventilation level does not appear to be linear, with variations in ventilation, for instance due to manufacturing tolerances, having less impact at lower target ventilation levels. For instance, with a ventilation tolerance of $\pm 15\%$, for a target ventilation level of 75%, the aerosol temperature could increase by approximately 6° C. at the lower ventilation limit (60% ventilation). However, with a target ventilation level of 60% the aerosol temperature may only increase by approximately 3.5° C. at the lower vent limit (45% ventilation). The target ventilation level of the article can therefore be within the range 40% to 70%, for instance, 45% to 65%. The mean ventilation level of at least 20 articles can be between 40% and 70%, for instance between 45% and 70% or between 51% and 59%.

[0111] In some embodiments, an additional wrapper **10** at least partially surrounds the aerosol generating material **2**, between the aerosol generating material **2** and the wrapper **6**. In particular, during manufacture of the article, the aerosol generating material is first wrapped by additional wrapper **10** before being attached in combination with the other components of the article **1a** by wrapper **6**.

[0112] In some embodiments, the additional wrapper **10** surrounding the aerosol generating material has a high level of permeability, for example greater than about 1000 Coresta Units, or greater than about 1500 Coresta Units, or greater than about 2000 Coresta Units. The permeability of the additional wrapper **10** can be measured in accordance with ISO 2965:2009 concerning the determination of air permeability for materials used as cigarette papers, filter plug wrap and filter joining paper.

[0113] The additional wrapper **10** may be formed from a material with a high inherent level of permeability, an inherently porous material, or may be formed from a material with any level of inherent permeability where the final level of permeability is achieved by providing the additional wrapper **10** with a permeable zone or area. Providing a permeable additional wrapper **10** provides a route for air to enter the smoking article. The additional wrapper **10** can be provided with a permeability such that the amount of air entering through the rod of aerosol generating material **2** is relatively more than the amount of air entering the article **1a** through the ventilation area **12** in the mouthpiece. An article **1a** having this arrangement may produce a more flavorsome aerosol which may be more satisfactory to the user.

[0114] In the embodiment illustrated by FIG. 1, the article **1a** further comprises a second tubular body **5** disposed between the aerosol generating material **2** and the first tubular body **3**. The length of the second tubular body **5** is such that it extends away from the heater **101** of the non-combustible aerosol provision device **100** by at least the minimum distance *d* to provide the necessary separation between the first tubular body **3** and the heater.

[0115] The second tubular body **5** defines a cavity **5a** between the aerosol generating material **2** and the first tubular body **3**, wherein the length of the cavity **5a** is such that it extends away from the heater **101** of the non-combustible aerosol provision device **100** by at least about

3 mm when the article is inserted into the non-combustible aerosol provision device **100**.

[0116] The second tubular body **5** is formed from paper. Specifically, the second tubular body **5** comprises a paper tube **5** underlying the wrapper **6**. The paper tube provides additional rigidity to the article **1a** around the cavity **5a**.

[0117] Preferably, the second tubular body **5** has a wall thickness of at least 200 microns, at least 300 microns and/or a permeability of at least 100 Coresta units. By constructing the second tubular body **5** to have a permeability of at least 100 Coresta units, the second tubular body **5** takes up moisture from aerosol generated by the aerosol generating material **2** when the article **1a** is heated by the non-combustible aerosol provision device **100**. Furthermore, papers with permeability greater than 100 Coresta units are generally low weight and easier to work with during manufacturing.

[0118] In the embodiment illustrated by FIG. 2, the length of the rod of aerosol generating material **2** is such that it extends away from the heater **101** of the non-combustible aerosol provision device **100** by the minimum distance *d* when the article **1b** is inserted into the non-combustible aerosol provision device **100**. Therefore, the rod of aerosol generating material **2** provides the necessary separation between the first tubular body **3** and the heater without having to space the first tubular body **3** from the rod of aerosol generating material.

[0119] In an embodiment illustrated by FIG. 3, the first tubular body is separated from the aerosol generating material **2** such that, when the article **1c** is inserted into the non-combustible aerosol provision device **100**, the minimum distance *d* between the heater **101** of the non-combustible aerosol provision device **100** and the first tubular body **3** is maintained. The space between the aerosol generating material **2** and the first tubular body **3** defines a cavity **6a**.

[0120] In the embodiments illustrated by FIGS. 1 to 3, the mouth end section **20** comprises a third tubular body **22**. The third tubular body **22** defines the mouth end of the articles **1a-c**. The third tubular body **22** may comprise a tube of cellulose acetate stiffened with plasticizer. The third tubular body **22** defines a cavity **22a** in the mouth end section **20** that opens at the mouth end.

[0121] In some embodiments, it can be particularly advantageous to use a tubular body **22** having a length of greater than about 10 mm, for instance between about 10 mm and about 30 mm or between about 12 mm and about 25 mm. It has been found that a consumer's lips are likely to extend in some cases to about 12 mm from the mouth end of the article **1** when drawing aerosol through the article **1**, and therefore a tubular body **22** having a length of at least 10 mm or at least 12 mm means that most of the consumer's lips surround this element **4**.

[0122] The articles **1a-c** include a body of material **21**. The body of material **21** is wrapped in an additional wrapping material, such as a first plug wrap **23**. Preferably, the first plug wrap **23** has a basis weight of less than 50 gsm, more preferably between about 20 gsm and 40 gsm. Preferably, the first plug wrap **23** has a thickness of between 30 μm and 60 μm , more preferably between 35 μm and 45 μm . Preferably, the first plug wrap **23** is a non-porous plug wrap, for instance having a permeability of less than 100 Coresta units, for instance less than 50 Coresta units. However, in

other embodiments, the first plug wrap **23** can be a porous plug wrap, for instance having a permeability of greater than 200 Coresta units.

[0123] Preferably, the length of the body of material **21** is less than about 15 mm. More preferably, the length of the body of material **21** is less than about 10 mm. In addition, or as an alternative, the length of the body of material **21** is at least about 5 mm. Preferably, the length of the body of material **21** is at least about 6 mm. In some preferred embodiments, the length of the body of material **21** is from about 5 mm to about 15 mm, more preferably from about 6 mm to about 12 mm, even more preferably from about 8 mm to about 12 mm, most preferably about 8 mm, 9 mm or 10 mm. In the present example, the length of the body of material **21** is 10 mm.

[0124] In the present example, the body of material **21** is formed from filamentary tow. In the present example, the tow used in the body of material **21** has a denier per filament (d.p.f.) of 8.4 and a total denier of 21,000. Alternatively, the tow can, for instance, have a denier per filament (d.p.f.) of 9.5 and a total denier of 12,000. Alternatively, the tow can, for instance, have a denier per filament (d.p.f.) of 8 and a total denier of 15,000. In the present example, the tow comprises plasticized cellulose acetate tow. The plasticizer used in the tow comprises about 7% by weight of the tow. In the present example, the plasticizer is triacetin. In other examples, different materials can be used to form the body of material **21**. For instance, rather than tow, the body **21** can be formed from paper, for instance in a similar way to paper filters known for use in cigarettes. Alternatively, the body **21** can be formed from tows other than cellulose acetate, for instance polylactic acid (PLA), other materials described herein for filamentary tow or similar materials. The tow is preferably formed from cellulose acetate. The tow, whether formed from cellulose acetate or other materials, preferably has a d.p.f. of at least 5, more preferably at least 6 and still more preferably at least 7. These values of denier per filament provide a tow which has relatively coarse, thick fibers with a lower surface area which result in a lower pressure drop across the body of material **21** than tows having lower d.p.f. values. Preferably, to achieve a sufficiently uniform body of material **21**, the tow has a denier per filament of no more than 12 d.p.f., preferably no more than 11 d.p.f. and still more preferably no more than 10 d.p.f.

[0125] The total denier of the tow forming the body of material **21** is preferably at most 30,000, more preferably at most 28,000 and still more preferably at most 25,000. These values of total denier provide a tow which takes up a reduced proportion of the cross sectional area of the article **1** which results in a lower pressure drop across the article **1** than tows having higher total denier values. For appropriate firmness of the body of material **21**, the tow preferably has a total denier of at least 8,000 and more preferably at least 10,000. Preferably, the denier per filament is between 5 and 12 while the total denier is between 10,000 and 25,000. More preferably, the denier per filament is between 6 and 10 while the total denier is between 11,000 and 22,000. Preferably the cross-sectional shape of the filaments of tow are 'Y' shaped, although in other embodiments other shapes such as 'X' shaped or 'O' shaped filaments can be used, with the same d.p.f. and total denier values as provided herein. The tow may comprise filaments having a cross-section with an isoperimetric ratio of 25 or less, preferably 20 or less, and more preferably 15 or less. In some examples, the body of

material **21** may comprise an adsorbent material (e.g. charcoal) dispersed within the tow.

[0126] In some examples, the body of material **21** may comprise a capsule. The capsule can comprise a breakable capsule, for instance a capsule which has a solid, frangible shell surrounding a liquid payload. In some examples, a single capsule is used. The capsule is entirely embedded within the body of material **21**. In other words, the capsule is completely surrounded by the material forming the body. In other examples, a plurality of breakable capsules may be disposed within the body of material **21**, for instance 2, 3 or more breakable capsules. The length of the body of material **21** can be increased to accommodate the number of capsules required. In examples where a plurality of capsules is used, the individual capsules may be the same as each other, or may differ from one another in terms of size and/or capsule payload. In other examples, multiple bodies of material may be provided, with each body containing one or more capsules.

[0127] In some embodiments, a non-combustible aerosol provision system is provided comprising an aerosol-modifying component and a heater **101** which, in use, is operable to heat the aerosol generating material such that the aerosol generating material provides an aerosol. The aerosol-modifying component comprises first and second capsules. The first capsule is disposed in a first portion of the aerosol-modifying component and the second capsule is disposed in a second portion of the aerosol modifying component downstream of the first portion.

[0128] The first portion of the aerosol-modifying component is heated to a first temperature during operation of the heater **101** to generate the aerosol and the second portion is heated to a second temperature during operation of the heater to generate aerosol, wherein the second temperature is at least 4 degrees Celsius lower than the first temperature. Preferably, the second temperature is at least 5, 6, 7, 8, 9 or 10 degrees Celsius lower than the first temperature.

[0129] The aerosol-modifying component may comprise one or more components of the article. In some embodiments, the aerosol-modifying component comprises a body of material **21**, wherein the first and second capsules are disposed in the body of material **21**. The body of material may comprise cellulose acetate or paper. In another embodiment, the aerosol-modifying component comprises two bodies of material, wherein the first and second capsules are disposed in the first and second bodies respectively. In some embodiments, the aerosol-modifying component alternatively or additionally comprises one or more tubular elements upstream and/or downstream of the body or bodies of material. The aerosol-generating component may comprise the mouthpiece.

[0130] In some embodiments, the second capsule is spaced from the first capsule by a distance of at least 7 mm, measured as the distance between the center of the first and second capsules. Preferably, the second capsule is spaced from the first capsule by a distance of at least 8, 9 or 10 mm. It has been found that increasing the distance between the first and second capsules increases the difference between the first and second temperatures.

[0131] The first capsule comprises an aerosol-modifying agent. The second capsule comprises an aerosol modifying agent which may be the same or different as the aerosol modifying agent of the first capsule. In some embodiments, a user may selectively rupture the first and second capsules

by applying an external force to the aerosol-modifying component in order to release the aerosol modifying agent from each capsule.

[0132] The aerosol-modifying agent of the second capsule is heated to a lower temperature than the aerosol-modifying agent of the first capsule due to the difference between the first and second temperatures.

[0133] The aerosol-modifying agents of the first and second capsules can be selected based on this temperature difference. For instance, the first capsule may comprise a first aerosol modifying agent that has a lower vapor pressure than a second aerosol modifying agent of the second capsule. If the capsules were both heated to the same temperature, then the higher vapor pressure of the aerosol modifying agent of the second capsule would mean that a greater amount of the second aerosol modifying agent would be volatilized relative to the aerosol modifying agent of the first capsule. However, since the second capsule is heated to a lower temperature, this effect is less pronounced such that a more even amount of the aerosol modifying agents of the first and second capsules are volatilized upon breaking of the first and second capsules respectively.

[0134] In some embodiments, the first and second capsules have the same aerosol-modifying profiles, meaning that both capsules contain the same type of aerosol-modifying agent and in the same amount such that if both capsules were heated to the same temperature and broken then both capsules would cause the same modification of the aerosol. However, since the first capsule is heated to a higher temperature than the second capsule, more of the aerosol-modifying agent of the first capsule will be, for example, volatilized compared to the modifying agent of the second capsule and thus will cause a more pronounced modification of the aerosol than the second capsule. Therefore, despite both capsules being the same, which may make the aerosol modifying component easier and/or less expensive to manufacture, the user can decide whether to break the first capsule to cause a more pronounced modification of the aerosol, or the second capsule to cause a less pronounced modification of the aerosol, or both capsules to cause the greatest modification of the aerosol.

[0135] In some embodiments, the first and second capsules both comprise first and second aerosol modifying agents. The first aerosol-modifying agent has a lower vapor pressure than the second aerosol modifying agent. Thus, when the second capsule is broken, a greater proportion of the second aerosol-modifying agent will be vaporized relative to the first aerosol modifying agent in comparison to when the hotter first capsule is broken during use of the system to generate aerosol. Therefore, the same capsule can be used to generate different modifications of the aerosol based on the position of the capsule in the first or second portion of the aerosol-modifying component.

[0136] The capsule has a core-shell structure. In other words, the capsule comprises a shell encapsulating a liquid agent, for instance a flavorant or other agent, which can be any one of the flavorants or aerosol modifying agents described herein. The shell of the capsule can be ruptured by a user to release the flavorant or other agent into the body of material **21**. The first plug wrap **23** can comprise a barrier coating to make the material of the plug wrap substantially impermeable to the liquid payload of the capsule. Alternatively or in addition, the second plug wrap **23** and/or wrapping material **6** can comprise a barrier coating to make

the material of that plug wrap **23** and/or wrapping material **6** substantially impermeable to the liquid payload of the capsule.

[0137] In some examples, the capsule is spherical and has a diameter of about 3 mm. In other examples, other shapes and sizes of capsule can be used. The total weight of the capsule may be in the range about 10 mg to about 50 mg.

[0138] It is known to generate, for a given tow specification (such as 8.4Y21000), a tow capability curve which represents the pressure drop through a length of rod formed using the tow, for each of a range of tow weights. Parameters such as the rod length and circumference, wrapper thickness and tow plasticizer level are specified, and these are combined with the tow specification to generate the tow capability curve, which gives an indication of the pressure drop which would be provided by different tow weights between the minimum and maximum weights achievable using standard filter rod forming machinery. Such tow capability curves can be calculated, for instance, using software available from tow suppliers. It has been found that it is particularly advantageous to use a body of material **21**, which includes filamentary tow having a weight per mm of length of the body of material **21**, which is between about 10% and about 30% of the range between the minimum and maximum weights of a tow capability curve generated for the filamentary tow. This can provide an acceptable balance between providing enough tow weight to avoid shrinkage after the body **21** has been formed, providing an acceptable pressure drop, while also assisting with capsule placement within the tow, for capsules of the sizes described herein.

[0139] The third tubular body **22** is separated from the first tubular body **3** by the body of material **21**. The plug wrap **23** attaches the third tubular body **22** to the body of material **21**. In particular, during manufacture of the article, the third tubular body **22** is first attached to the body of material **21** by plug wrap **23** before being attached in combination with the other components of the article **1** by wrapper **6**.

[0140] It shall be appreciated that the third tubular body **22** is not essential and may be omitted. For example, in the article **1d** illustrated by FIG. 4, the mouth end of the mouth end section **20'** comprises the body of material **21** adjacent the first tubular body **3**.

[0141] In another embodiment illustrated by FIG. 4a, the mouth end section **20''** of the article **1e** comprises a body of material **21** separated from the first tubular body **3** by a fourth tubular body **24**.

[0142] In another embodiment illustrated by FIG. 4b, the mouth end section **20'''** of the article **1f** comprises a body of material **21** comprising an inner body **21a** and an outer body **21b**. The outer body **21b** is a tube that surrounds the inner body **21a**. The resistance to gaseous flow through the length of the inner body **21a** is less than a resistance to gaseous flow through the length of the outer body **21b**. This may be achieved by providing an outer body **21b** having a greater fibre density to the inner body **21a**.

[0143] In another embodiment illustrated in section by FIG. 5, the mouth end section **20''''** of the article **1g** comprises a body of material **21** with a non-circular cross section. In this embodiment, the sheet of additional wrapping material **23** extending between the body of material **21** and the wrapper **6** comprises a pattern of strength discontinuities. Said strength discontinuities result in non-uniformity in the curvature of at least a portion of said additional wrapping material **23** to give the body of material **21** its

non-circular cross section. In the illustrated embodiment, the additional wrapping material **23** and body of material **21** within the additional wrapping material **23** present a star shaped cross section.

[0144] In the tobacco material described herein, the tobacco material contains an aerosol forming material. In this context, an “aerosol forming material” is an agent that promotes the generation of an aerosol. An aerosol forming material may promote the generation of an aerosol by promoting an initial vaporization and/or the condensation of a gas to an inhalable solid and/or liquid aerosol. In some embodiments, an aerosol forming material may improve the delivery of flavor from the aerosol generating material. In general, any suitable aerosol forming material or agents may be included in the aerosol generating material of the invention, including those described herein. Other suitable aerosol forming materials include, but are not limited to: a polyol such as sorbitol, glycerol, and glycols like propylene glycol or triethylene glycol; a non-polyol such as monohydric alcohols, high boiling point hydrocarbons, acids such as lactic acid, glycerol derivatives, esters such as diacetin, triacetin, triethylene glycol diacetate, triethyl citrate or myristates including ethyl myristate and isopropyl myristate and aliphatic carboxylic acid esters such as methyl stearate, dimethyl dodecanedioate and dimethyl tetradecanedioate. In some embodiments, the aerosol forming material may be glycerol, propylene glycol, or a mixture of glycerol and propylene glycol. The total amount of glycerol, propylene glycol, or a mixture of glycerol and propylene glycol used may be in the range of between 10% and 30%, for instance between 15% and 25% of the tobacco material measured on a dry weight basis. Glycerol may be present in an amount of from 10 to 20% by weight of the tobacco material, for example 13 to 16% by weight of the composition, or about 14% or 15% by weight of the composition. Propylene glycol, if present, may be present in an amount of from 0.1 to 0.3% by weight of the composition.

[0145] The aerosol forming material may be included in any component, for example any tobacco component, of the tobacco material, and/or in the filler component, if present. Alternatively or additionally, the aerosol forming material may be added to the tobacco material separately. In either case, the total amount of the aerosol forming material in the tobacco material can be as defined herein.

[0146] A method of manufacturing an article for use with a non-combustible aerosol provision device **100** comprising a heater **101** will now be described with reference to FIG. 6. The method comprises:

[0147] the step S1 of providing an aerosol generating material **2** comprising at least one aerosol forming material;

[0148] the step S2 of disposing a first tubular body **3** downstream of the aerosol generating material, the tubular body **3** comprising filamentary tow; and

[0149] the step S3 of disposing a mouth end section **20** downstream of the tubular body. The article can be configured such that when the article is inserted into the non-combustible aerosol provision device, the minimum distance between the heater of the non-combustible aerosol provision device and the tubular body is at least about 3 mm.

[0150] FIG. 7 shows an example of a non-combustible aerosol provision device **100** comprising a heater **101** for generating aerosol from an aerosol generating medium/

material such as the aerosol generating material **2** of the articles described herein. In broad outline, the device **100** may be used to heat a replaceable article **110** comprising the aerosol-generating medium, for instance any of the articles described herein, to generate an aerosol or other inhalable medium which is inhaled by a user of the device **100**. The device **100** and replaceable article **110** together form a system.

[0151] The device **100** comprises a housing **102** (in the form of an outer cover) which surrounds and houses various components of the device **100**. The device **100** has an opening **104** in one end, through which the article **110** may be inserted for heating by a heater **101**, hereinafter referred to as the heating assembly. In use, the article **110** may be fully or partially inserted into the heating assembly where it may be heated by one or more components of the heater assembly.

[0152] The device **100** of this example comprises a first end member **106** which comprises a lid **108** which is moveable relative to the first end member **106** to close the opening **104** when no article **110** is in place. In FIG. 7, the lid **108** is shown in an open configuration, however the lid **108** may move into a closed configuration. For example, a user may cause the lid **108** to slide in the direction of arrow “B”.

[0153] The device **100** may also include a user-operable control element **112**, such as a button or switch, which operates the device **100** when pressed. For example, a user may turn on the device **100** by operating the switch **112**.

[0154] The device **100** may also comprise an electrical component, such as a socket/port **114**, which can receive a cable to charge a battery of the device **100**. For example, the socket **114** may be a charging port, such as a USB charging port.

[0155] FIG. 8 depicts the device **100** of FIG. 7 with the outer cover **102** removed and without an article **110** present. The device **100** defines a longitudinal axis **134**.

[0156] As shown in FIG. 8, the first end member **106** is arranged at one end of the device **100** and a second end member **116** is arranged at an opposite end of the device **100**. The first and second end members **106**, **116** together at least partially define end surfaces of the device **100**. For example, the bottom surface of the second end member **116** at least partially defines a bottom surface of the device **100**. Edges of the outer cover **102** may also define a portion of the end surfaces. In this example, the lid **108** also defines a portion of a top surface of the device **100**.

[0157] The end of the device closest to the opening **104** may be known as the proximal end (or mouth end) of the device **100** because, in use, it is closest to the mouth of the user. In use, a user inserts an article **110** into the opening **104**, operates the user control **112** to begin heating the aerosol generating material and draws on the aerosol generated in the device. This causes the aerosol to flow through the device **100** along a flow path towards the proximal end of the device **100**.

[0158] The other end of the device furthest away from the opening **104** may be known as the distal end of the device **100** because, in use, it is the end furthest away from the mouth of the user. As a user draws on the aerosol generated in the device, the aerosol flows away from the distal end of the device **100**.

[0159] The device **100** further comprises a power source **118**. The power source **118** may be, for example, a battery,

such as a rechargeable battery or a non-rechargeable battery. Examples of suitable batteries include, for example, a lithium battery (such as a lithium-ion battery), a nickel battery (such as a nickel—cadmium battery), and an alkaline battery. The battery is electrically coupled to the heating assembly to supply electrical power when required and under control of a controller (not shown) to heat the aerosol generating material. In this example, the battery is connected to a central support 120 which holds the battery 118 in place.

[0160] The device further comprises at least one electronics module 122. The electronics module 122 may comprise, for example, a printed circuit board (PCB). The PCB 122 may support at least one controller, such as a processor, and memory. The PCB 122 may also comprise one or more electrical tracks to electrically connect together various electronic components of the device 100. For example, the battery terminals may be electrically connected to the PCB 122 so that power can be distributed throughout the device 100. The socket 114 may also be electrically coupled to the battery via the electrical tracks.

[0161] In the example device 100, the heating assembly is an inductive heating assembly and comprises various components to heat the aerosol generating material of the article 110 via an inductive heating process. Induction heating is a process of heating an electrically conducting object (such as a susceptor) by electromagnetic induction. An induction heating assembly may comprise an inductive element, for example, one or more inductor coils, and a device for passing a varying electric current, such as an alternating electric current, through the inductive element. The varying electric current in the inductive element produces a varying magnetic field. The varying magnetic field penetrates a susceptor suitably positioned with respect to the inductive element, and generates eddy currents inside the susceptor. The susceptor has electrical resistance to the eddy currents, and hence the flow of the eddy currents against this resistance causes the susceptor to be heated by Joule heating. In cases where the susceptor comprises ferromagnetic material such as iron, nickel or cobalt, heat may also be generated by magnetic hysteresis losses in the susceptor, i.e. by the varying orientation of magnetic dipoles in the magnetic material as a result of their alignment with the varying magnetic field. In inductive heating, as compared to heating by conduction for example, heat is generated inside the susceptor, allowing for rapid heating. Further, there need not be any physical contact between the inductive heater and the susceptor, allowing for enhanced freedom in construction and application.

[0162] The induction heating assembly of the example device 100 comprises a susceptor arrangement 132 (herein referred to as “a susceptor”), a first inductor coil 124 and a second inductor coil 126. The first and second inductor coils 124, 126 are made from an electrically conducting material. In this example, the first and second inductor coils 124, 126 are made from Litz wire/cable which is wound in a helical fashion to provide helical inductor coils 124, 126. Litz wire comprises a plurality of individual wires which are individually insulated and are twisted together to form a single wire. Litz wires are designed to reduce the skin effect losses in a conductor. In the example device 100, the first and second inductor coils 124, 126 are made from copper Litz wire which has a rectangular cross section. In other examples the Litz wire can have other shape cross sections, such as circular.

[0163] The first inductor coil 124 is configured to generate a first varying magnetic field for heating a first section of the susceptor 132 and the second inductor coil 126 is configured to generate a second varying magnetic field for heating a second section of the susceptor 132. In this example, the first inductor coil 124 is adjacent to the second inductor coil 126 in a direction along the longitudinal axis 134 of the device 100 (that is, the first and second inductor coils 124, 126 do not overlap). The susceptor arrangement 132 may comprise a single susceptor, or two or more separate susceptors. Ends 130 of the first and second inductor coils 124, 126 can be connected to the PCB 122.

[0164] It will be appreciated that the first and second inductor coils 124, 126, in some examples, may have at least one characteristic different from each other. For example, the first inductor coil 124 may have at least one characteristic different from the second inductor coil 126. More specifically, in one example, the first inductor coil 124 may have a different value of inductance than the second inductor coil 126. In FIG. 8, the first and second inductor coils 124, 126 are of different lengths such that the first inductor coil 124 is wound over a smaller section of the susceptor 132 than the second inductor coil 126. Thus, the first inductor coil 124 may comprise a different number of turns than the second inductor coil 126 (assuming that the spacing between individual turns is substantially the same). In yet another example, the first inductor coil 124 may be made from a different material to the second inductor coil 126. In some examples, the first and second inductor coils 124, 126 may be substantially identical.

[0165] In this example, the first inductor coil 124 and the second inductor coil 126 are wound in opposite directions. This can be useful when the inductor coils are active at different times. For example, initially, the first inductor coil 124 may be operating to heat a first section/portion of the article 110, and at a later time, the second inductor coil 126 may be operating to heat a second section/portion of the article 110. Winding the coils in opposite directions helps reduce the current induced in the inactive coil when used in conjunction with a particular type of control circuit. In FIG. 8, the first inductor coil 124 is a right-hand helix and the second inductor coil 126 is a left-hand helix. However, in another embodiment, the inductor coils 124, 126 may be wound in the same direction, or the first inductor coil 124 may be a left-hand helix and the second inductor coil 126 may be a right-hand helix.

[0166] The susceptor 132 of this example is hollow and therefore defines a receptacle within which aerosol generating material is received. For example, the article 110 can be inserted into the susceptor 132. In this example the susceptor 120 is tubular, with a circular cross section.

[0167] The susceptor 132 may be made from one or more materials. Preferably the susceptor 132 comprises carbon steel having a coating of Nickel or Cobalt.

[0168] In some examples, the susceptor 132 may comprise at least two materials capable of being heated at two different frequencies for selective aerosolization of the at least two materials. For example, a first section of the susceptor 132 (which is heated by the first inductor coil 124) may comprise a first material, and a second section of the susceptor 132 which is heated by the second inductor coil 126 may comprise a second, different material. In another example, the first section may comprise first and second materials, where the first and second materials can be heated

differently based upon operation of the first inductor coil **124**. The first and second materials may be adjacent along an axis defined by the susceptor **132**, or may form different layers within the susceptor **132**. Similarly, the second section may comprise third and fourth materials, where the third and fourth materials can be heated differently based upon operation of the second inductor coil **126**. The third and fourth materials may be adjacent along an axis defined by the susceptor **132**, or may form different layers within the susceptor **132**. Third material may be the same as the first material, and the fourth material may be the same as the second material, for example. Alternatively, each of the materials may be different. The susceptor may comprise carbon steel or aluminum for example.

[0169] The device **100** of FIG. **8** further comprises an insulating member **128** which may be generally tubular and at least partially surround the susceptor **132**. The insulating member **128** may be constructed from any insulating material, such as plastic for example. In this particular example, the insulating member is constructed from polyether ether ketone (PEEK). The insulating member **128** may help insulate the various components of the device **100** from the heat generated in the susceptor **132**.

[0170] The insulating member **128** can also fully or partially support the first and second inductor coils **124**, **126**. For example, as shown in FIG. **8**, the first and second inductor coils **124**, **126** are positioned around the insulating member **128** and are in contact with a radially outward surface of the insulating member **128**. In some examples the insulating member **128** does not abut the first and second inductor coils **124**, **126**. For example, a small gap may be present between the outer surface of the insulating member **128** and the inner surface of the first and second inductor coils **124**, **126**.

[0171] In a specific example, the susceptor **132**, the insulating member **128**, and the first and second inductor coils **124**, **126** are coaxial around a central longitudinal axis of the susceptor **132**.

[0172] FIG. **9** shows a side view of device **100** in partial cross-section. The outer cover **102** is present in this example. The rectangular cross-sectional shape of the first and second inductor coils **124**, **126** is more clearly visible.

[0173] The device **100** further comprises a support **136** which engages one end of the susceptor **132** to hold the susceptor **132** in place. The support **136** is connected to the second end member **116**.

[0174] The device may also comprise a second printed circuit board **138** associated within the control element **112**.

[0175] The device **100** further comprises a second lid/cap **140** and a spring **142**, arranged towards the distal end of the device **100**. The spring **142** allows the second lid **140** to be opened, to provide access to the susceptor **132**. A user may open the second lid **140** to clean the susceptor **132** and/or the support **136**.

[0176] The device **100** further comprises an expansion chamber **144** which extends away from a proximal end of the susceptor **132** towards the opening **104** of the device. Located at least partially within the expansion chamber **144** is a retention clip **146** to abut and hold the article **110** when received within the device **100**. The expansion chamber **144** is connected to the end member **106**.

[0177] FIG. **10** is an exploded view of the device **100** of FIG. **9**, with the outer cover **102** omitted.

[0178] FIG. **11A** depicts a cross section of a portion of the device **100** of FIG. **9**. FIG. **11B** depicts a close-up of a region of FIG. **11A**. FIGS. **11A** and **11B** show the article **110** received within the susceptor **132**, where the article **110** is dimensioned so that the outer surface of the article **110** abuts the inner surface of the susceptor **132**. This ensures that the heating is most efficient. The article **110** of this example comprises aerosol generating material **110a**. The aerosol generating material **110a** is positioned within the susceptor **132**. The article **110** may also comprise other components such as a filter, wrapping materials and/or a cooling structure.

[0179] FIG. **11B** shows that the outer surface of the susceptor **132** is spaced apart from the inner surface of the inductor coils **124**, **126** by a distance **150**, measured in a direction perpendicular to a longitudinal axis **158** of the susceptor **132**. In one particular example, the distance **150** is about 3 mm to 4 mm, about 3-3.5 mm, or about 3.25 mm.

[0180] FIG. **11B** further shows that the outer surface of the insulating member **128** is spaced apart from the inner surface of the inductor coils **124**, **126** by a distance **152**, measured in a direction perpendicular to a longitudinal axis **158** of the susceptor **132**. In one particular example, the distance **152** is about 0.05 mm. In another example, the distance **152** is substantially 0 mm, such that the inductor coils **124**, **126** abut and touch the insulating member **128**.

[0181] In one example, the susceptor **132** has a wall thickness **154** of about 0.025 mm to 1 mm, or about 0.05 mm.

[0182] In one example, the susceptor **132** has a length of about 40 mm to 60 mm, about 40 mm to 45 mm, or about 44.5 mm.

[0183] In one example, the insulating member **128** has a wall thickness **156** of about 0.25 mm to 2 mm, 0.25 mm to 1 mm, or about 0.5 mm.

[0184] In use, any of the articles described herein can be inserted into a non-combustible aerosol provision device such as the device **100** described with reference to FIGS. **7** to **11**. At least a portion of the mouthpiece **20**, **20'**, **20''**, **20'''**, **20''''** of the article protrudes from the non-combustible aerosol provision device **100** and can be placed into a user's mouth. An aerosol is produced by heating the aerosol generating material **2** using the device **100**. The aerosol produced by the aerosol generating material **2** passes through the mouthpiece **20**, **20'**, **20''**, **20'''**, **20''''** to the user's mouth.

[0185] The various embodiments described herein are presented only to assist in understanding and teaching the claimed features. These embodiments are provided as a representative sample of embodiments only, and are not exhaustive and/or exclusive. It is to be understood that advantages, embodiments, examples, functions, features, structures, and/or other aspects described herein are not to be considered limitations on the scope of the invention as defined by the claims or limitations on equivalents to the claims, and that other embodiments may be utilized and modifications may be made without departing from the scope of the claimed invention. Various embodiments of the invention may suitably comprise, consist of, or consist essentially of, appropriate combinations of the disclosed elements, components, features, parts, steps, means, etc, other than those specifically described herein. In addition, this disclosure may include other inventions not presently claimed, but which may be claimed in future.

1. An article for use with a non-combustible aerosol provision device comprising a heater, the article comprising: an aerosol generating material comprising at least one aerosol forming material;

a first tubular body disposed downstream of the aerosol generating material, the first tubular body comprising filamentary tow; and

a mouth end section disposed downstream of the first tubular body,

wherein the article is configured such that when the article is inserted into the non-combustible aerosol provision device, the minimum distance between the heater of the non-combustible aerosol provision device and the first tubular body is at least about 3 mm.

2. An article according to claim 1, further comprising a second tubular body disposed between the aerosol generating material and the first tubular body, wherein the length of the second tubular body is such that it extends away from the heater of the non-combustible aerosol provision device by at least about 3 mm when the article is inserted into the non-combustible aerosol provision device.

3. An article according to claim 2, wherein the second tubular body is formed from paper.

4. An article according to claim 2, wherein the second tubular body has a wall thickness of at least 300 microns and/or a permeability of at least 100 Coresta units.

5. An article according to claim 1, wherein the length of the aerosol generating material is such that it extends away from the heater of the non-combustible aerosol provision device by at least about 3 mm when the article is inserted into the non-combustible aerosol provision device.

6. An article according to claim 1, further comprising a wrapper at least partially surrounding the aerosol generating material and the first tubular body.

7. An article according to claim 6, wherein the wrapper defines a cavity between the aerosol generating material and the first tubular body, wherein the length of the cavity is such that it extends away from the heater of the non-combustible aerosol provision device by at least about 3 mm when the article is inserted into the non-combustible aerosol provision device.

8. An article according to claim 6, wherein the wrapper has a citrate content of 1% by weight or less.

9. An article according to claim 1, wherein the first tubular body has a wall thickness between 0.5 mm and 2.5 mm.

10. An article according to claim 1, wherein the first tubular body has a length of at least 12 mm.

11. An article according to claim 1, wherein the filamentary tow of the first tubular body comprises filaments having a cross-section with an isoperimetric ratio of 25 or less.

12. An article according to claim 1, further comprising at least one ventilation area arranged to allow external air to flow into the article.

13. An article according to claim 12, wherein said at least one ventilation area is arranged to provide external air into the aerosol generating material.

14. An article according to claim 12, wherein said at least one ventilation area is arranged to provide external air into a cavity of the first tubular body.

15. An article according to claim 12, wherein said at least one ventilation area comprises a single row of ventilation apertures.

16. An article according to claim 12, wherein said at least one ventilation area comprises two or more rows of ventilation apertures.

17. An article according to claim 12, wherein the level of ventilation provided by said at least one ventilation area is within the range of 45% to 65% of the volume of aerosol generated by said non-combustible aerosol provision device passing through the article, or between 40% and 60% of the volume of aerosol generated by said non-combustible aerosol provision device passing through the article.

18. An article according to claim 1, wherein mouth end section comprises a third tubular body.

19. An article according to claim 18, wherein the third tubular body defines the mouth end of the article.

20. An article according to claim 18, wherein the third tubular body comprises a length of greater than about 10 mm or greater than about 12 mm.

21. An article according to claim 1, wherein the mouth end section comprises an inner body and an outer body, wherein a resistance to gaseous flow through the length of the inner body is less than a resistance to gaseous flow through the length of the outer body.

22. An article according to claim 1, further comprising a sheet material having a pattern of strength discontinuities resulting in non-uniformity in the curvature of at least a portion of said sheet material.

23. An article according to claim 1, wherein the first tubular body comprises a second aerosol generating material.

24. An article according to claim 1, wherein the aerosol generating material is wrapped by a wrapper having a level of permeability greater than about 2000 Coresta Units, and wherein the article comprises a downstream portion downstream of the aerosol generating material, comprising at least one ventilation area.

25. An article according to claim 1, wherein the mouth end section comprises a body of filamentary tow, wherein said filamentary tow of the body of filamentary tow comprises a weight per mm of length of the body which is between about 10% and about 30% of the range between the minimum and maximum weights of a tow capability curve generated for the filamentary tow.

26. A system comprising:

a non-combustible aerosol provision device comprising a heater; and

an article according to claim 1.

27. A method of manufacturing an article for use with a non-combustible aerosol provision device comprising a heater, the method comprising:

providing an aerosol generating material comprising at least one aerosol forming material; and

disposing a tubular body downstream of the aerosol generating material, the tubular body comprising filamentary tow;

disposing a mouth end section downstream of the tubular body; and

wherein the article is configured such that when the article is inserted into the non-combustible aerosol provision device, the minimum distance between the heater of the non-combustible aerosol provision device and the tubular body is at least 3 mm.