

(19) **DANMARK**

(10) **DK/EP 3192081 T3**



Patent- og
Varemærkestyrelsen

(12) **Oversættelse af
europæisk patentskrift**

-
- (51) Int.Cl.: **B 05 C 3/00 (2006.01)** **B 05 C 3/12 (2006.01)** **B 05 C 11/10 (2006.01)**
B 29 C 47/02 (2006.01) **B 29 C 47/20 (2006.01)** **H 01 B 13/06 (2006.01)**
- (45) Oversættelsen bekendtgjort den: **2019-06-11**
- (80) Dato for Den Europæiske Patentmyndigheds bekendtgørelse om meddelelse af patentet: **2019-03-13**
- (86) Europæisk ansøgning nr.: **15757567.1**
- (86) Europæisk indleveringsdag: **2015-09-01**
- (87) Den europæiske ansøgnings publiceringsdag: **2017-07-19**
- (86) International ansøgning nr.: **GB2015052519**
- (87) Internationalt publikationsnr.: **WO2016038335**
- (30) Prioritet: **2014-09-12 RU 2014137032** **2014-09-24 RU 2014138561**
2014-12-19 GB 201422745
- (84) Designerede stater: **AL AT BE BG CH CY CZ DE DK EE ES FI FR GB GR HR HU IE IS IT LI LT LU LV MC MK MT NL NO PL PT RO RS SE SI SK SM TR**
- (73) Patenthaver: **Asterope Ltd., Office 5A, Ealing House, 33 Hanger Lane, London W5 3HJ, Storbritannien**
- (72) Opfinder: **VEGLIA, Filippo Gionata Diego, Via Sabaudia 15 bis, I-10133 Torino, Italien**
DEGASPERI, Piero, Via Marighetto 78, I-38123 Trento, Italien
TAIARIOL, Francesco, Piazza Diaz 1, I-10090 San Giusto Canavese, Italien
- (74) Fuldmægtig i Danmark: **Plougmann Vingtoft A/S, Strandvejen 70, 2900 Hellerup, Danmark**
- (54) Benævnelse: **FREMGANGSMÅDE TIL TRÅDCOATING**
- (56) Fremdragne publikationer:
US-A- 4 505 222
US-A- 4 601 918
US-A- 4 733 630
US-A- 5 358 570

DESCRIPTION

Field

[0001] The field of the present invention is the coating of wires. More particularly, embodiments of the invention improve on known industrial techniques for coating wires by avoiding the use of solvents as the primary agent for applying a coating to a wire.

Background

[0002] There are many applications that require metal wires with a plastic outer coating. The coating of a wire has functional purpose. For example, the plastic coating may be necessary to electrically insulate the wire. Such a coating may be required to withstand large temperatures as are experienced in applications such as electromagnets, transformers, motors and speakers. Other functional effects of a coating include increasing the corrosion resistance of the wire and a coating also provides a layer of protection between the wire and any items that the wire is attached to. This functionality may be required for applications such as wires for fencing, construction, agriculture and packaging. The coating can also be used to associate a wire with a colour. This has the advantages of clearly distinguishing the purpose of a wire, such as the different wires of a household plug or the wires connected to positive and negative battery terminals, or the properties of a wire, such as its resistance or type.

[0003] The process of applying a coating to a wire is an important part of its manufacture. The industrial manufacture of coated wire requires large quantities of coated wire to be produced quickly and efficiently.

[0004] Known industrial processes for applying a plastic, i.e. polymer, coating to a wire first dissolve the polymer in a solvent. The polymer is a polymeric material. The solvent solution is applied to the wire when the wire is being passed through an extrusion die. The wire is then subsequently heated within an oven, at a temperature of 700°C or higher. This causes the solvent to evaporate and leaves behind a coating of the polymer on the wire.

[0005] Although this method is the industry standard, there are a number of inherent problems with this approach. As well as the solvent being expensive, the solvents used for dissolving the polymer are carcinogenic and highly polluting. It is therefore necessary to treat the fumes produced when evaporating solvent in the heating oven before the fumes are released into the atmosphere. The process is also energy intensive and the costs involved are high. Known extrusion devices are also limited in the accuracy and uniformity of the coating they provide. Wires therefore need to be recoated a large number of times, typically 8 to 20 times, by multiple passes through the solvent based coating apparatus and oven to ensure a coating of the required thickness is achieved. It is also difficult to pause or stop the coating process once

the process has begun. Manufacturers are therefore required to continuously produce coated wire in long runs. The method is also a delicate process. If the heating is performed too quickly, the evaporation of the solvents causes blisters on the wire and thereby reduces the quality of the coating.

[0006] There are no known alternative techniques for coating wires that are suitable for producing coated wire on an industrial scale.

[0007] Various solvent free techniques for coating wires have been experimented with for very low levels of production.

[0008] Electrostatically coating a wire by a powder has also been tried. However, this results in the coating being applied unevenly and can only be applied on large rectangular sections of metal.

[0009] Known techniques that have used a hot bath of thermosetting materials with low levels of solvents have not proved to be a viable alternative to the above-described solvent based techniques. The instability of the resins is a problem and it is not known how to provide a coating on a wire with good technical specifications. Attempts at using thermoplastics have also resulted in the coatings being both too thick and with a thickness that is difficult to control.

[0010] US4549421B describes an apparatus and method for pressurising a wire in order to reduce its thickness. By passing the wire through a reservoir of molten thermoplastic material the wire is also coated. However, the disclosed technique inherently reduces the diameter of the wire due to a pressure differential that is created and the technique cannot be used to only apply one or more layers of coating to a wire without also reducing the diameter of the wire. The disclosed technique also experiences the above-identified problems of the coating being too thick and the thickness being difficult to control. Accordingly, the disclosed technique is not viable for effective industrial production of wire.

[0011] Accordingly, a number of problems are experienced by known processes for coating wires and it is not known how to provide a technique for coating a wire on an industrial scale that does not use solvents as the primary agent for applying the coating to the wire.

[0012] US 4 505 222 A discloses background art.

US 4 604 918 A discloses background art.

US 5 358 570 A discloses background art.

US 4 733 630 A discloses background art.

Summary of Invention

[0013] According to a first aspect of the invention, there is provided a coating apparatus for applying a coating material to a wire according to claim 1.

[0014] Preferably, a number of heating elements are provided around the injection channel and are arranged and controllable to heat at least some coating material in the injection channel to at least a first temperature such that the at least some coating material heated to the at least first temperature is in a state that is able to flow down the length of the injection channel.

[0015] Preferably, a number of heating elements are provided around the coating chamber that are arranged and controllable to further heat at least some coating material to at least a second temperature, higher than the first temperature, in the coating chamber, such that the coating material has said desired viscosity at the second temperature so that the coating material can be applied to the wire.

Preferably, the second temperature is lower than the thermosetting temperature of the coating material.

Preferably, the apparatus further comprises a pressuriser that is configured to pressurise the contents of the injection channel and coating chamber, the applied pressure causing the coating material to flow down the injection channel. Preferably, the injection channel comprises a first cylindrical section at the first end of the channel and a second cylindrical section at the second end of the channel, wherein the diameter of the first cylindrical section is greater than the second cylindrical section.

Preferably, the volume of the second cylindrical section is less than the volume of the first cylindrical section.

Preferably, the number of heating elements provided around the injection channel are arranged and controllable to heat the contents of the second cylindrical section to a higher temperature than the contents of the first cylindrical section but to a lower temperature than the second temperature.

Preferably, the pressuriser is a piston that is moveable along the length of the first cylindrical section of the injection channel.

[0016] Preferably, the wire travels through the coating chamber along the longitudinal axis of the central section.

Preferably, the longitudinal axis of the central section of the coating chamber is perpendicular to the longitudinal axis of the injection channel.

Preferably, the nozzle is detachable from the central section of the coating chamber.

Preferably, the first temperature is in the range 40°C to 120°C.

Preferably, the number of heating elements provided around the injection channel are arranged and controllable to heat the contents of the first cylindrical section to a temperature in the range 40°C to 80°C and the contents of the second cylindrical section to a temperature in the range 80°C to 120°C.

Preferably, the second temperature is in the range 120°C to 220°C.

Preferably, the pressuriser is controlled such that the pressure in the coating chamber is in the range 5MPa to 100MPa.

Preferably, the pressuriser is controlled to maintain a constant pressure in the coating chamber when the coating apparatus applies a layer of coating material to the wire.

[0017] Preferably, the coating material is a thermosetting polymer, the coating material comprising one or more of polyester, epoxy-polyester mixture, polyesterimide, polyesterimide and amideimide mixture, polyethylene, polyethylenimine, polyurethane, polyamide, epoxy, polyamide-imide, polyvinyl formal and thermosetting additives.

[0018] According to a second aspect of the invention there is provided a coating system comprising the coating apparatus according to the first aspect of the invention, an oven, a cooling chamber and a control system; wherein: the coating apparatus is arranged to receive wire and to apply a layer of coating material, that is a thermosetting material, to the received wire; the oven is arranged to receive wire output from the coating apparatus and to heat the wire to a temperature at which the applied coating material sets; the cooling chamber is arranged to receive wire output from the oven and to cool the wire such that the wire output from the cooling chamber can be wound or fed back into the coating apparatus for a further layer of coating material to be applied; and the control system is configured to control the heating elements in the coating apparatus, the temperature of the oven and the speed of the wire through the coating apparatus, oven and cooling chamber.

[0019] Preferably, the control system is configured to control the pressure applied by the pressuriser of the coating apparatus.

[0020] Preferably, the control system is controlled to maintain a constant pressure in the coating chamber of the coating apparatus when the coating apparatus applies a layer of coating material to the wire.

[0021] Preferably, the control system is arranged to receive information identifying the type of wire to be coated and the type of coating material to be used; and the control system is configured to determine the temperatures that the coating apparatus and oven are to be controlled to, and, the pressure applied by the pressuriser, in dependence on the received information.

[0022] Preferably, the control system is configured to control the first temperature in the control apparatus to be in the range 40°C to 120°C.

[0023] Preferably, the control system is configured to control the one or more heating elements provided around the injection channel to heat the contents of the first cylindrical section to a temperature in the range 40°C to 80°C and the contents of the second cylindrical section to a temperature in the range 80°C to 120°C.

[0024] Preferably, the control system is configured to control the second temperature in the control apparatus to be in the range 120°C to 220°C.

Preferably, the control system is configured to control the pressuriser such that the pressure in the coating chamber is in the range 5MPa to 100MPa. Preferably, the control system is configured to control the oven to heat the wire to a temperature in the range 300°C to 400°C.

Preferably, the coating material is a thermosetting polymer, the coating material comprising one or more of polyester, polyesterimide, polyetherimide and amideimide mixture, epoxy-polyester mixture, epoxy polyethylene, polyethylenimine, polyurethane, polyamide, polyamideimide, polyvinyl formal and thermosetting additives.

[0025] According to a third aspect of the invention there is provided a method of applying coating material to a wire comprising: providing a fluid path for channelling a thermosetting coating material; and progressively raising the temperature of the coating material as the coating material travels along the fluid path, such that the coating material is at a desired viscosity at the end of the fluid path for applying the coating material to a wire, wherein the fluid path is provided by the coating apparatus according to the first aspect of the invention.

[0026] Preferably, the method according to the third aspect of the invention comprising; supplying coating material, that is a thermosetting material, to the injection channel of the coating apparatus; heating the coating material in the injection channel to a first temperature such that the coating material flows into the coating chamber of the coating apparatus; heating the coating material in the coating chamber to a second temperature, higher than the first temperature, such that the coating material has an appropriate viscosity for being applied to a wire, wherein the second temperature is lower than the temperature at which the thermosetting material sets; and feeding wire through the coating chamber of the coating apparatus so as to apply the coating material to the wire.

[0027] Preferably, the method further comprising pressurising the coating material in the coating chamber prior to feeding wire through the coating chamber; and maintaining pressure throughout the coating process.

[0028] Preferably, the method wherein the first temperature is in the range 40°C to 120°C.

[0029] Preferably, the method wherein the second temperature is in the range 120°C to 220°C.

[0030] Preferably, the method wherein the pressure in the coating chamber is in the range 5MPa to 100MPa.

[0031] According to a fourth aspect of the invention a method in a coating system for applying a coating material to a wire, the method comprising feeding wire through the coating system according to the second aspect of the invention, the method comprising applying a layer of thermosetting polymer material to a wire by feeding the wire through the system.

[0032] Preferably, the method further comprising: determining the thickness of the coating applied to a wire that has been output from the cooling chamber of the coating system; and determining to feed the wire through the coating system again if the thickness of the coating is less than a desired thickness and/or if the coating does not have a desired uniformity of thickness such that the wire is repeatedly fed through the coating system until the wire has a

desired coating thickness and/or uniformity of thickness; and determining to end the coating process if the coating has a desired thickness and/or uniformity of thickness.

Description of the Drawings

[0033]

Figure 1 shows a cross section through a wire coating apparatus according to an embodiment of the invention.

Figure 2 shows a cross section through a wire coating apparatus according to an embodiment of the invention.

Figure 3 shows a cross section through a wire coating apparatus according to an embodiment of the invention.

Figure 4 shows a coating system for use with thermosetting coating materials according to an embodiment of the invention.

Figure 5 shows how the coating apparatus may be implemented in the coating system.

Figure 6 shows a flowchart of a method of applying a coating material to a wire according to an embodiment of the invention.

Detailed Description

[0034] Embodiments of the present invention provide a method, apparatus and system for coating a wire. Embodiments provide a wire coating technique that is suitable for the industrial production of coated wire and overcomes at least some of the problems experienced by known industrial production techniques.

[0035] Embodiments may be used to apply a coating to any type of wire. The wire may comprise any type of metal for use as wire. Preferably, the wire is made of copper, aluminium, or steel. The type of wire will depend on the application of the wire. Copper and aluminium wire is typically used for electrical applications such as a winding of an electromagnet. Steel wire is typically used for applications such as construction and packing. To aid adherence of the coating material to the wire, the wire is preferably thoroughly cleaned of all impurities prior to a coating process. In particular, for copper wire, the copper has preferably been annealed prior to the coating process.

[0036] The coating is a plastic material. Preferably, the applied coating is a thermosetting polymer material. The specific type of thermosetting material that is used may depend on the

type of metal that the wire is made of and/or the desired properties of the coating. Prior to being fed into a wire coating apparatus 100, the coating may be a powder, liquid, solid pellets, chips or cartridges or have other forms that are generally known for paints and enamels.

[0037] Embodiments provide a coating apparatus 100 that receives a wire, that may be uncoated or already have one or more layers of coating applied. The coating apparatus 100 applies an outer coating of a thermosetting material to the received wire 105. The temperatures and pressures within the device are controlled to provide a relatively small coating chamber comprising coating material at an appropriate viscosity for applying to a wire 105 but below the thermosetting temperature of the coating material. The coating is applied to the wire by passing the wire through the coating chamber. The wire is then fed to an oven 401 in which it is heated to a temperature at which the thermosetting coating material sets. The wire is then passed through a cooling chamber 402. If it is necessary to increase the thickness of the coating of the wire 105, the wire 105 is re-fed through the coating apparatus 100 and other parts of the system as many times as required. The number of passes through the system required is typically one to four.

[0038] Advantageously, embodiments provide an industrial process for applying a coating to a wire 105 that is easier, safer and cheaper than known techniques that require the use of solvents as the primary agent for applying a plastic coating to a wire. By accurately controlling the temperatures throughout the coating apparatus 100, molten thermosetting material is directly applied to a wire. Embodiments are also more efficient than known techniques because the required temperatures are lower. The oven 401 for heating the wire 105 can also be smaller as it is not required to extract and process the fumes of evaporating solvents. The process according to embodiments can also be easily and accurately controlled. The coated wires manufactured according to embodiments have equivalent functionality to coated wires generated according to known techniques.

[0039] An embodiment of a coating apparatus 100 for applying the coating to a wire 105 is shown in Figures 1 and 2.

[0040] Figures 1 and 2 show cross-sections through the coating apparatus 100. Figure 1 is an end on view along the axis of wire 105 that is passed through the coating apparatus 100. Figure 2 is a side on view of the apparatus showing a perpendicular cross-section to that in Figure 1.

[0041] The coating apparatus 100 comprises an injection channel 107 for receiving coating material and feeding the coating material to a chamber where the coating material is applied to a wire 105. The injection channel 107 comprises an inlet portion 104 through which coating material is fed into the apparatus. The injection channel 107 comprises a reservoir of coating material. The top of the injection channel 107 is an upper cylindrical section 101. The bottom of the upper cylindrical section 101 tapers conically and at its narrower end continues as the lower cylindrical section 102, that has a smaller diameter than the upper cylindrical section 101. The bottom end of the lower cylindrical section 102 connects into a coating chamber 103.

The interior of the injection channel 107 and the interior of the coating chamber 103 are in fluid communication with each other such that the injection channel 107 is a feed for supplying coating material to the coating chamber 103.

[0042] Provided within the upper cylindrical section 101 of the injection channel 107 is a piston 106. The piston 106 can move along the upper cylindrical section 101 of the injection channel 107. The movement of the piston 106 along the injection channel 107 towards the coating chamber 103 has the effect of pressurising coating material in the injection channel 107. Present, although not shown in Figures 1 and 2, is a drive mechanism for moving the piston 106 along the upper cylindrical section 101. The drive mechanism may be hydraulic and is preferably automatically controlled.

[0043] The central section of the coating chamber 103 is a cylinder, the axis of which is located perpendicularly to the axis of the injection channel 107. Wire 105 for coating is passed through the coating chamber 103, along the axis of the cylindrical central section of the coating chamber 103. As shown in Figure 2, the end of the coating chamber 103 that receives the wire feed has a seal, preferably made of a polymeric material, at the inlet port where the wire 105 enters the coating chamber 103. Preferably the seal is fixed in place by a fixing element located on the external surface of the coating apparatus 100. During a coating operation, the coating apparatus 100 is therefore hermetically sealed and the contents of the coating chamber 103 are prevented from escaping through the inlet port. The other end of the coating chamber 103 comprises a coating nozzle 108. The wire 105 feed exits the coating chamber 103 through the coating nozzle 108.

[0044] The coating nozzle 108 is formed with its shape in the coating chamber 103 being a cone that narrows towards the outlet port of the wire 105 from the coating chamber 103. The coating nozzle 108 may be made integral with the rest of the coating chamber 103. Preferably, the coating nozzle 108 is a separable unit that is connectable to the rest of the coating chamber 103, for example by a thread or screw, however any method of attachment that can be conceived could be used. This allows coating nozzles with different diameters of outlet port to be used, as is appropriate for generating different diameters of coated wire 105. Coating nozzle 108 in Figure 2 is shown with preferable proportions and to a preferable scale. In one embodiment a nozzle outlet port diameter of $0.980\text{mm} \pm 0.005\text{mm}$ is used with an opening angle of 10° to 20° of the cone. However alternative nozzle geometries can be envisaged. The conical shape to the nozzle has the advantageous effect of generating hydrodynamic forces that aid the application of coating material within the coating chamber 103 to wire 105 that is being passed through the nozzle. The hydrodynamic forces automatically centre the wire 105 in the middle of the nozzle and this improves the uniformity of the applied coating. The nozzle geometry also supports the use of high wire feed speeds and the stress on the wire 105 is low. The different opening angle geometries of the nozzle enable different wire speeds to be achieved as the opening angle defines the applied shear forces. There is no direct physical contact between the nozzle and a wire 105 that is being coated and this improves the durability of the nozzle and prevents damage to the wire 105. The thickness of the applied coating depends on the diameter of the outlet port from the nozzle. For each operation of a coating

process, a nozzle design can be chosen that results in a desired coating thickness. The nozzle can be replaced with another nozzle with a different opening angle and/or outlet port diameter between different passes through the apparatus after passing through the coating oven. Alternatively the wire could be passed through a series of nozzles during one coating pass. The different nozzles may be of the same dimensions or may have differing dimensions. Advantageously, through the choice of the nozzle, a coating thickness as small as 15 microns is possible as well as thicker coatings.

[0045] The coating apparatus 100 also comprises at least one pressure sensor so that the pressure within the coating apparatus 100 during a coating operation can be determined.

[0046] The coating apparatus provides a fluid path that the thermosetting coating material passes through. During this process the temperature of the coating material is progressively raised, such that it is at the desired viscosity at the end of the fluid path for applying the coating material to a wire. In one specific embodiment the fluid path may be formed of the injection channel 107 and the coating chamber 103. The temperature of the coating material is progressively raised along the fluid path by a number of controllable heating elements.

[0047] Figure 3 shows three temperature zones within the coating apparatus 100. Temperature Zone 1, TZ1, comprises the upper cylindrical section 101 of the injection channel 107. Temperature Zone 2, TZ2, comprises the lower cylindrical section 102 of the injection channel 107. Temperature Zone 3, TZ3, comprises the coating chamber 103. Each temperature zone has a different temperature profile. It should be noted that the shown locations of the temperature zones are approximate. The temperature zones indicate different regions within the apparatus in which at least some, and preferably most, of the coating material in the region is heated to within a temperature range associated with the temperature zone. The desired temperature ranges within each temperature zone will depend on the specific coating material being used.

[0048] The coating apparatus 100 also comprises a plurality of heating elements 109. The effect of the heaters is to heat different parts of the apparatus to different temperatures. The heating elements 109 can be inserted into holes within the metal casing of the apparatus, with a means of fixing 110. The heating elements are preferably evenly distributed throughout the coating apparatus 100 to ensure heat transfer from the metal to the coating material is uniform. Typically these heating elements 109 can be co-axial or radial to the chamber geometry. In one embodiment the heating elements in TZ1 can be co-axial with the injection channel 107, radial with the lower cylindrical section 102 in TZ2, and radial with the coating chamber 103 in TZ3. Preferably, 4 or 6 heating elements are arranged at regular intervals to ensure uniform heating; however any number of heating elements with any arrangement could be used. The heating elements are preferably electrical resistances. However, any type of heating element as known in the art may be used. The heating elements typically have powers of 70 to 200W. The heating elements are typically small cylinders, 6.5mm in diameter and about 40-60mm long, however any other geometry that can be envisaged could be used.

[0049] The coating apparatus 100 also comprises a plurality of temperature sensors 111 to allow accurate control of the temperatures throughout the coating apparatus 100. The temperature sensors can be thermometers, temperature probes or any other means of measuring temperatures. This control can be by varying the power output of the heating elements 109 to regulate the temperature. As shown in Figures 1 and 2 each temperature zone comprises one temperature sensor 111, however in certain embodiments more than one temperature sensor in each temperature zone could be included. Temperature sensors 111 are inserted within a hole in the metal casing with the temperature sensitive part of the temperature sensor as close to the coating material as possible. In certain embodiments the temperature sensor can be located to measure in the centre of the thermal zone. The temperature of the metal casing close to the coating material gives a good estimate of the temperature of the coating material as the metal casing is in contact with the coating material, transferring the heat from the heating elements to the coating material. The accuracy of the temperature measurement will improve as the temperatures in the coating apparatus reach a steady state after a coating operation being started, so that the measured temperatures are an accurate measure of the temperature of the coating material.

[0050] The metal casing ensures that uniform heating of the coating material is maintained within each thermal zone. This is ensured by the mass of the metal casing being a lot larger than the mass of the coating material, and the slow flow rate of the coating material within each temperature zone, thus the temperature gradients between the metal casing and coating material should be small during steady state operation. Temperature gradients will be particularly small in TZ3, where the coating chamber 103 is preferably made of a high conductivity alloy such as copper-beryllium to minimise the temperature differences as the polymer nears the coating nozzle 108. The external surface of the coating chamber 103 is preferably covered with insulating material to help maintain the internal temperature of the coating chamber 103 and to improve the safety of the coating apparatus 100.

[0051] Although not shown in Figures 1 to 3, each of the temperature zones preferably has a layer of thermal insulation provided between the metal parts used to construct the different temperatures zones within the coating apparatus 100. This reduces the heat transmission through the body parts of the coating apparatus 100 and therefore helps to maintain the different temperatures of the temperature zones within the coating apparatus 100.

[0052] At the point of application of the coating material to a wire 105, which occurs in TZ3, the coating material needs to be at a viscosity appropriate for application to the wire 105, the viscosity being dependent of the temperature and pressure of the coating material. The purpose of the different temperature zones is to provide a sufficient amount of coating material at the desired viscosity, i.e. temperature and pressure, for applying to a wire 105 in the coating chamber 103, the coating material having been progressively heated by the different zones to the required temperature in TZ3. The coating material will be at its lowest viscosity state at the point of application of coating to the wire.

[0053] Attachment between the different components of the apparatus is achieved by bolts

112. The bolts 112 used are designed to withstand the pressure and force generated within the injection channel 107 by the piston when in operation. Dowel pins 113 are functionally used to keep perfect alignment of the injection channel 107 with the rest of the apparatus.

[0054] The coating material is fed into the coating apparatus 100 through the inlet portion 104. The coating material is received in the upper cylindrical section 101 of the injection chamber in TZ1. The coating material is then heated within TZ1 to a temperature at which the coating material is in a rubbery state and able to flow when pressurised by the piston 106.

[0055] The piston 106 is then actuated so that it pressurises the coating material within the upper cylindrical section 101. The coating material is pressurised by the piston 106 to the pressure at which it is desired to apply the coating material to the wire 105. Once this pressure is reached, the piston 106 does not pressurise the coating material further but is controlled to maintain the pressure within the injection channel 107, and coating chamber 103, constantly at the desired pressure for applying the coating material to the wire 105.

[0056] The effect of heating and pressurising the coating material in TZ1 is to ensure that the coating material is in a state in which it flows from the upper cylindrical section 101 through the tapered conical section and into the lower cylindrical section 102 in TZ2. The coating material is preferably heated to be in a rubbery state rather than a liquid state. The diameter and length of the lower cylindrical section 102 are less than those of the upper cylindrical section 101 and the volume of coating material in the lower cylindrical section 102 is therefore a lot less than that in the upper cylindrical section 101. In TZ2, the coating material is heated to a higher temperature than it was in TZ1 and its viscosity therefore decreases.

[0057] The coating material flows from the lower cylindrical section 102 into the coating chamber 103 in TZ3. The amount of coating material in the coating chamber 103 is very small due to the low volume of the coating chamber 103. In TZ3, the coating material is heated to a higher temperature. Preferably, the coating material remains in a rubbery state in TZ2 and, in response to being heated further in TZ3, the viscosity of the coating material in TZ3 decreases to a desired level for applying the coating material to a wire 105. The coating material may be a liquid in TZ3. Preferably, the maximum temperature in TZ3 is sufficient to liquefy thermosetting coating materials but controlled to be below the temperature at which curing of the thermosetting material occurs.

[0058] During a coating operation, wire 105 is fed through the coating chamber 103 with coating material therein being at an appropriate viscosity for applying to the wire 105. The conical shape of the coating nozzle 108 results in hydrodynamic forces being generated within the coating nozzle 108 when the wire 105 is fed through the coating nozzle 108. Advantageously, this results in very effective application of the coating material to the wire 105.

[0059] The wire 105 output from the coating apparatus 100 therefore has a thin layer of coating material applied to it by the coating apparatus 100. Advantageously, the coating operation can be performed with a high wire feed speed and the application of the layer to the

wire 105 is substantially uniform.

[0060] As the coating material flows along the injection tube and into the coating chamber 103 in response to the pressure from the piston 106 and, if the coating apparatus 100 is located vertically, due to the force of gravity, the piston 106 moves along the upper cylindrical section 101 towards the coating chamber 103 to maintain the desired pressure.

[0061] The effect of heating the coating material in a plurality of temperature zones, with the amount of coating material in TZ3 being less than that in TZ2, and the amount of coating material in TZ2 being less than that in TZ1, is that only a very small amount of coating material for applying to a wire 105 is at the correct temperature and pressure for this. Advantageously, the coating operations are easy to pause or stop since most of the coating material is not at the temperature at which it is least viscous. It is easy to remove coating material from the coating apparatus 100 if it is in a rubbery or solid state and so stopping a coating process does not result in the coating material clogging up the coating apparatus 100. Thermosetting coating materials are also not heated to the temperature that causes them to set as so they do not irreversibly harden within the apparatus.

[0062] The temperature zones TZ1 and TZ2 advantageously ensure that the heating elements for TZ3 are easily able to heat the coating material that flows into the coating chamber 103 to replace coating material that has been applied to a wire 105 to the required temperature in TZ3 because the replacement coating material has already been heated.

[0063] The different thermal zones within the coating chamber 103 are controlled to be at stable temperatures. Advantageously, the thermal zones slowly bring the coating material to a temperature where its viscosity is the lowest but below the temperature at which polymerization begins. The gradual increase in the temperature of the coating material occurs as the coating material progresses through the apparatus.

[0064] Figure 4 shows a coating system for use with thermosetting coating materials according to embodiments. The system comprises the coating apparatus 100 according to the above-described embodiments, an oven 401, a cooling chamber 402 and a control system 403.

[0065] Figure 5 shows how the coating apparatus 100 may be implemented in the coating system.

[0066] During a wire coating operation, wire 105 is fed into the coating apparatus 100 that applies a layer of coating material, that is a thermosetting material, to the wire 105. In the presently described embodiment, the wire 105 input to the coating apparatus 100 is uncoated wire 105. The wire 105 output from the coating apparatus 100 is fed into the oven 401. The oven 401, which may be an annealing oven 401 or curing oven 401, heats the coating material to a temperature at which the thermosetting material sets thereby hardening the applied layer of coating material on the wire 105. The setting is caused by polymerisation of the thermosetting material as cross links are formed.

[0067] The wire 105 is then fed into a cooling chamber 402 where it is cooled to a temperature at which it either be wound, or fed back into the coating apparatus 100.

[0068] If the coating on the wire 105 has the desired thickness, the coated wire 105 is ready for use. It would typically be wound on a large drum at this stage.

[0069] If a thicker coating on the wire 105 is desired then the coated wire 105 is fed back into the coating apparatus 100 and the process of applying a layer of thermosetting polymer to the wire 105, heating the wire 105 to a temperature that causes the newly applied thermosetting polymer to set and then cooling the wire 105 is repeated as many times as required. Preferably, a thin coating, that may be 15 microns thick, is applied two to four times as the multiple applications improve the uniformity of the coating thickness. Additional passes through the apparatus strengthens the coating and improves its mechanical characteristics.

[0070] One specific embodiment of this invention is in the coating of copper wire for use as magnet wire. Copper wire of a uniform thickness of 1 mm can be coated using a coating material comprised of a mix of polyvinylformal, bisphenol epoxy, curing agents. Temperature ranges of the thermal zones preferable for this coating process are TZ1 40 to 80°C, TZ2 80 to 120°C, and TZ3 120 to 220°C. For example, the control system may control heating elements to 60°C in TZ1, 100°C in TZ2 and 170°C in TZ3. Wire coating speeds of 25 m/min are achievable with this particular polymer. Preferably, at least two passes through the apparatus are made and three or four passes are preferable to better achieve a uniform wire coating thickness. Coating thickness of between 15 to 45 microns can be achieved.

[0071] In a further embodiment of this invention coating is applied to steel wire. Steel wire with a thickness of 0.96 mm is coated with a polyester polymer (mix 70% polyester, 30% epoxy). Temperature ranges of the thermal zones preferable for this coating process are TZ1 40 to 60°C, TZ2 60 to 77.5°C, and TZ3 77.5 to 95°C. For example, the control system may control heating elements to 50°C in TZ1, 70°C in TZ2 and 85°C in TZ3. In this embodiment coating speeds of 75 m/min can be reached, with a coating of 15 to 45 microns achieved in a single pass through the apparatus.

[0072] The control system 403 automatically controls the entire wire coating process. The control system 403 receives the user input of the properties of the wire 105 to be coated and the type, and properties (in particular thickness), of the coating material to be applied to the wire 105. The control system 403 then determines the required temperatures of the temperature zones within the coating apparatus 100, the required pressure within the coating apparatus 100, the required temperature of the oven 401 and the required wire feed speed in dependence of the properties of the wire 105 and/or coating material. The control system 403 then controls the coating apparatus 100 so that the temperature zones within it are heated to the required temperatures, controls the drive mechanism of the piston 106 to apply the desired pressure within the coating apparatus 100, controls the heaters of the oven 401 so that the oven 401 is at the required temperature and then controls a wire feeder to feed the wire 105

through the coating system at the required speed. The control system 403 receives feedback of the actual wire feed speed, temperatures and pressures throughout the coating system and uses the feedback information to accurately control all of these parameters throughout the coating system.

[0073] Wire coating speeds range between 30 to 100 m/min, with typical working speeds of 50, 75 and 100 m/min. Wire speeds depend upon the nature of the wire being coated, for instance diameters, materials, and the coating material, for instance its viscosity. In some implementations it is preferable to operate the coating system with a lower wire feed speed than the maximum achievable as this ensures that the wire is in the curing oven for longer. The oven can therefore be operated at a lower temperature than that required for higher wire feed speeds and this decreases the energy requirements.

[0074] A wide range of coating materials and wire 105 types are compatible with the coating system. The control system 403 is able to easily adapt the temperatures, pressures and wire feed speeds used to appropriate levels given the specific materials being used and the desired properties of the manufactured coated wire 105.

[0075] Although not shown in Figure 4, the coating system would also comprise devices for feeding wire 105 through the system, winding wire 105 that has been coated etc. These devices and their implementation would be known to a person skilled in the art.

[0076] The coating material could be any of a large number of thermosetting polymers. The thermosetting polymers may comprise any of polyester, epoxy-polyester mixture, polyethylene, polyethylenimine, polyurethane, polyamide, polyamide-imide, a thermosetting polyvinyl formal compound, epoxy, polyesterimide, and other materials. The coating material may be a mixture of any of these polymers as well as with other substances, in particular thermosetting additives. For example, a mixture comprising 60% polyvinyl formal and 40% thermosetting additive, or polyesterimide and amideimide mixture, may be used.

[0077] Suitable such polymer materials are known and available from at least ELANTAS (<http://www.elantas.com/elantas-italia/products/electro-insulating-enamels-primary-insulation.html>, as viewed on 20 November 2014).

[0078] Coating materials that are already known for use in solvent based wire coating techniques can be used in embodiments.

[0079] The form of the coating material could be any of a powder, liquid, solid pellets, chips or cartridges or other forms that are generally known for paints and enamels.

[0080] The desired thermal profiles of the different temperature zones depend upon the polymer material being used, with the minimum viscosity achieved at different temperatures for different polymers.

[0081] For one specific embodiment of the disclosed invention for coating copper wire with coating material comprising a mix of polyvinylformal, bisphenol epoxy, curing agents:

In TZ1, the temperature of most of the coating material would typically be heated to temperature in the range of 40 to 80°C.

In TZ2, the temperature of most of the coating material would typically be heated to temperature in the range of 80 to 120°C.

In TZ3, the temperature of most of the coating material would typically be heated to temperature in the range of 120 to 220°C.

[0082] In a second embodiment of the disclosed invention for coating steel wire with a coating material comprising a mixture of 70% polyester, 30% epoxy:

In TZ1, the temperature of most of the coating material would typically be heated to temperature of 50°C.

In TZ2, the temperature of most of the coating material would typically be heated to temperature of 70°C.

In TZ3, the temperature of most of the coating material would typically be heated to temperature of 80°C.

[0083] The pressure within the coating chamber 103 during a coating operation is preferably in the range of 5MPa to 100MPa.

[0084] The temperature of the oven 401 that heats the wire 105 to the temperature at which the thermosetting material sets is typically in the range 250 to 350 or 400 °C. The oven temperature depends upon the speed of the wire, as to reach the thermosetting temperature faster moving wire will require to be heated quicker, due to less time in the oven. Preferably, the heating is at atmospheric pressure.

[0085] The coating process according to embodiments is highly suited to the industrial production of coated wire 105. Embodiments allow a large quantity of coated wire 105 to be quickly produced in an inexpensive manner that avoids the problems of known solvent based techniques for coating wire 105. Embodiments also require lower temperatures than solvent based techniques and energy efficiency is also improved.

[0086] Advantageously, embodiments are able to apply a thin coating to a wire 105 with good accuracy and uniformity of the coating thickness. The thickness of a wire 105 is controllable since a coated wire 105 can be passed through the coating system if a thicker coating is required. The use of thermosetting materials is possible due to the accurate temperature

control throughout the apparatus preventing the setting of the material within the apparatus. Thermosetting materials are a higher quality coating than thermoplastics and perform better in high temperature applications.

[0087] Another advantage is that the system according to embodiments is highly adaptable and supports the use of a wide range of temperatures, pressures, wire feed speeds and coating material thicknesses. Embodiments are therefore suitable for applying a wide range of coating materials to a wide range of wire types.

[0088] Figure 6 is a flowchart of a method of applying a coating material to a wire according to an embodiment.

[0089] In step 601, the process begins.

[0090] In step 603, a fluid path is provided for channelling a thermosetting coating material.

[0091] In step 605, the temperature of the coating material is progressively raised as the coating material travels along the fluid path, such that the coating material is at a desired viscosity at the end of the fluid path for applying the coating material to a wire.

[0092] In step 607, the process ends.

[0093] A further embodiment of a method of applying a coating material to a wire comprises; a coating material, that is a thermosetting material, is supplied to the injection channel of a coating apparatus. The coating material in the injection channel is heated to a first temperature such that the coating material flows into the coating chamber of the coating apparatus. The coating material in the coating chamber is heated to a second temperature, higher than the first temperature, such that the coating material has an appropriate viscosity for being applied to a wire, wherein the second temperature is lower than the temperature at which the thermosetting material sets. Wire is fed through the coating chamber of the coating apparatus so as to apply the coating material to the wire.

[0094] Embodiments of the invention also include numerous modifications and variations to the above-described embodiments.

[0095] In the above-described embodiments, it is necessary for the injection channel 107 to either hold enough coating material for coating all of the wire 105 during a wire coating operation, or for a wire coating operation to be stopped when the coating material in the injection channel 107 has been used up, the piston 106 withdrawn so that more coating material can be fed into the apparatus, the coating material to be heated and pressurised again and then the coating operation restarted. In an alternative embodiment of the invention, the coating apparatus 100 comprises two injection channels and pistons in parallel with each other, with both of the injection channels arranged to feed coating material into the same

coating chamber 103. A first injection channel could be used during a wire coating operation. When the coating material in the first injection channel had all been used, the coating operation continues using a second injection channel. The first injection channel could be refilled whilst the second injection channel was being used. Advantageously, a coating operation can be run continuously without being stopped when the coating material in one of the injection channels runs out.

[0096] In the above-described embodiments, the coating apparatus 100 is described as having three temperature zones. This is a particularly preferable number of temperature zones for effective operation. However, embodiments also include coating apparatuses with two temperature zones or more than three temperature zones.

[0097] The feeding of the coating material into the injection channel 107 can be performed either manually or by an automatic feeding device.

[0098] In the above-described embodiments, a piston 106 is used to pressurise the coating material in the injection channel 107. In an alternative embodiment, an extrusion screw mechanism is used instead of a piston 106. This has the advantage of mixing the coating material in the injection channel 107, and achieving a better uniformity of flow of coating material in the coating chamber 103. The orientation of the screw or piston, or any other pressurising means, can be as shown in the figures, perpendicular to the coating chamber. Alternative orientations are conceivable with the pressurising means co-axial with the wire, or at any perceivable angle, such as but not limited to 30° and 120°. At different orientations the pressure required to keep a constant flow of coating material changes, with a lower pressure required at smaller angles. In the embodiment comprising a piston co-axial to the wire the piston comprises a hole to allow the wire to feed through.

[0099] The wire 105 being coated would typically have a circular cross-section. However, embodiments are able to apply a coating to wires of any cross-sectional shape. For example, the wire 105 being coated may have a rectangular cross-section as is preferred for the wiring of an electromagnet. The shape of the nozzle may be chosen such that the outlet port of the coating chamber 103 has a corresponding shape to the cross-section of the wire 105.

[0100] The lower cylindrical section 102 of the injection channel 107 may comprise a mixing device for mixing the coating material passed there through. This is preferable if the coating material comprises a mixture of substances. Such mixing devices are well known in the art.

[0101] Preferably the coating system comprises a device for automatically measuring the thickness of coated wire 105 that is output from the cooling chamber 402. The device would then automatically determine if one or more further passes through the coating system were required in order to achieve a desired wire 105 thickness.

[0102] Preferably the coating system also comprises a device for automatically measuring the thickness of wire 105, that may already have a coating, prior to input to the coating apparatus

100. The thickness of each applied layer to a wire 105 by the coating apparatus 100 could then be determined.

[0103] Preferably the coating system also comprises a device for automatically determining the uniformity of the thickness of wire 105 that is output from the cooling chamber 402. The performance of the coating system can then be monitored and any erroneous operation quickly detected.

[0104] The piston 106 may have a hydraulic drive mechanism. Preferably the drive mechanism comprises hydraulic dampers that decrease oscillations in the pressure induced by the continuous impulses of the hydraulic pump rotation. The driving force is therefore maintained substantially at a desired level and the pressure within the coating apparatus 100 accurately held at a desired level.

[0105] In the above-described embodiments, the injection channel 107 comprises cylindrical sections with circular cross sections. Although this is a preferable configuration, embodiments also include the injection channel 107 having alternative cross sectional shapes, such as hexagonal or square.

[0106] The coating apparatus 100 may also include one or more exit valves in the coating chamber 103 and/or injection channel 107 to aid the removal of the coating material after a coating operation.

The flowcharts and description thereof herein should not be understood to prescribe a fixed order of performing the method steps described therein. Rather, the method steps may be performed in any order that is practicable. Although the present invention has been described in connection with specific exemplary embodiments, it should be understood that various changes, substitutions, and alterations apparent to those skilled in the art can be made to the disclosed embodiments without departing scope of the invention as set forth in the appended claims.

REFERENCES CITED IN THE DESCRIPTION

This list of references cited by the applicant is for the reader's convenience only. It does not form part of the European patent document. Even though great care has been taken in compiling the references, errors or omissions cannot be excluded and the EPO disclaims all liability in this regard.

Patent documents cited in the description

- [US4549421B \[0010\]](#)

- US4505222A [0012]
- US4604918A [0012]
- US5358570A [0012]
- US4733630A [0012]

Non-patent literature cited in the description

- ELANTAS, 2014, [0077]

Patentkrav**1.** Coatingapparat (100) omfattende:

et coatingkammer (103) til at påføre et termohærdende coatingmateriale til en tråd (105), der passerer gennem coatingkammeret (103);

5 en aflang indsprøjtningskanal (107) til at modtage coatingmaterialeinput til coatingapparatet (100) ved en første ende af indsprøjtningskanalen (107) og at forsyne det modtagne coatingmateriale til coatingkammeret (103), der er indrettet ved en anden ende af indsprøjtningskanalen (107);

10 et antal af varmeelementer (109), der kan styres til at progressivt hæve temperaturen af coatingmaterialet, når coatingmaterialet strømmer gennem coatingapparatet (100) for at opnå en ønsket viskositet af coatingmaterialet inden i coatingkammeret (103); **kendetegnet ved at** coatingkammeret (103) har en indløbsåbning hvorigennem tråd (105) går ind i coatingkammeret (103), en udløbsåbning hvorigennem tråd (105) går

15 ud af coatingkammeret (103), og et cylindrisk afsnit mellem indløbsåbningen og udløbsåbningen til at modtage coatingmateriale fra indsprøjtningskanalen (107); og

hvor enden af coatingkammeret (103), der omfatter udløbsåbningen er en dyse (108), der tilspidser konisk fra en en maksimum diameter ved

20 forbindelsen med det cylindriske afsnit til en minimum diameter ved udløbsåbningen.

2. Apparat (100) ifølge krav 1, hvor et antal af varmeelementer (109) er tilvejebragt rundt om indsprøjtningskanalen (107) og, i anvendelse, varmer

25 mindst noget coatingmateriale i indsprøjtningskanalen (107) til mindst en første temperatur, så det mindst noget coatingmateriale, der varmes til den mindst første temperatur, er i en tilstand, så det er i stand til at strømme ned af længden af indsprøjtningskanalen (107).

30 **3.** Apparat (100) ifølge krav 2, hvor et antal af varmeelementer (109) er tilvejebragt rundt om coatingkammeret (103) og, i anvendelse, yderligere varmer mindst noget coatingmateriale til mindst en anden temperatur, højere end den første temperatur, i coatingkammeret (103), således at coatingmaterialet har nævnte ønskede viskositet ved den anden temperatur, så coatingmaterialet kan

påføres til tråden (105).

4. Apparat (100) ifølge krav 3, hvor, i anvendelse, den anden temperatur er lavere end den termohærdende temperatur af coatingmaterialet.

5

5. Apparat (100) ifølge krav 1, yderligere omfattende en trykholder, der er konfigureret til at sætte indholdet af indsprøjtningsskanalen (107) og coatingkammeret (103) under tryk, idet det påførte tryk forårsager, at coatingmaterialet strømmer ned af indsprøjtningsskanalen (107).

10

6. Apparat (100) ifølge et hvilket som helst af kravene 1 til 3, hvor indsprøjtningsskanalen (107) omfatter et første cylindrisk indsprøjtningsskanalafsnit (101) ved den første ende af kanalen og et andet cylindrisk indsprøjtningsskanalafsnit (102) ved den anden ende af kanalen, hvor diameteren af det første cylindriske indsprøjtningsskanalafsnit (101) er større end det andet cylindriske indsprøjtningsskanalafsnit (102), og fortrinsvis volumen af det andet cylindriske indsprøjtningsskanalafsnit (102) er mindre end volumen af det første cylindriske indsprøjtningsskanalafsnit (101).

15

7. Apparat (100) ifølge krav 6, når krav 6 er afhængigt af krav 3, hvor antallet af varmeelementer (109) tilvejebragt rundt om indsprøjtningsskanalen (107) er indrettet og kan styres til at varme indholdet af det andet cylindriske indsprøjtningsskanalafsnit (102) til en højere temperatur end indholdet af det første cylindriske indsprøjtningsskanalafsnit (101), men til en lavere temperatur end den anden temperatur.

25

8. Apparat (100) ifølge krav 6, eller et hvilket som helst krav afhængigt deraf, når krav 6 er afhængigt af krav 5, hvor trykholderen er et stempel (106), der er bevægeligt langs længden af det første cylindriske indsprøjtningsskanalafsnit (101) af indsprøjtningsskanalen (107).

30

9. Apparat (100) ifølge krav 1, hvor tråden (105) løber gennem coatingkammeret (103) langs den langsgående akse af det cylindriske afsnit, og/eller hvor den langsgående akse af det cylindriske afsnit af coatingkammeret (103) er vinkelret

på den langsgående akse af indsprøjtningsskanalen (107).

10. Apparat (100) ifølge krav 2 eller et hvilket som helst krav afhængigt deraf, hvor den første temperatur er i området 40°C til 120°C.

5

11. Apparat (100) ifølge krav 7 eller et hvilket som helst krav afhængigt deraf, hvor antallet af varmeelementer (109) tilvejebragt rundt om indsprøjtningsskanalen (107), i anvendelse, varmer indholdet af det første cylindriske indsprøjtningsskanalafsnit (101) til en temperatur i området 40°C til 80°C, og indholdet af det andet cylindriske indsprøjtningsskanalafsnit (102) til en temperatur i området 80°C til 120°C.

10

12. Apparat (100) ifølge krav 3 eller et hvilket som helst krav afhængigt deraf, hvor den anden temperatur er i området fra 120°C til 220°C.

15

13. Apparat (100) ifølge krav 5 eller et hvilket som helst krav afhængigt deraf, hvor trykholderen er styret til at fastholde et konstant tryk i coatingkammeret (103), når coatingapparatet (100) påfører et lag af coatingmateriale til tråden (105).

20

14. Coatingsystem omfattende coatingapparatet (100) ifølge et hvilket som helst foregående krav, en ovn (401), et kølekammer (402) og et styringssystem (403); hvor:

25

coatingapparatet (100) er indrettet til at modtage tråd (105) og til at påføre et lag af coatingmateriale, der er et termohærdende materiale, til den modtagne tråd (105);

ovnen (401) er anbragt til at modtage tråd (105)-output fra coatingapparatet (100) og til at varme tråden (105) til en temperatur ved hvilken det påførte coatingmateriale hærder;

30

kølekammeret (402) er indrettet til at modtage tråd (105)-output fra ovnen (401) og til at køle tråden (105), således at tråd (105)-outputet fra kølekammeret (402) kan vikles eller føres tilbage til coatingapparatet (100) for at et yderligere lag af coatingmateriale kan påføres; og

35

styringssystemet (403) er konfigureret til at styre varmeelementerne (109) i coatingapparatet (100), temperaturen af ovnen (401) og hastigheden af

tråden (105) gennem coatingapparatet (100), ovnen (401) og kølekammeret (402).

- 15.** Fremgangsmåde til at påføre coatingmateriale til en tråd (105) omfattende:
- 5 at tilvejebringe en væskevej til at kanalisere et termohærdende coatingmateriale; og
- progressivt at hæve temperaturen af coatingmaterialet, når coatingmaterialet gennemløber langs væskevejen, således at coatingmaterialet er ved en ønsket viskositet ved enden af væskevejen for
- 10 at påføre coatingmaterialet til en tråd (105), **kendetegnet ved at** væskevejen er tilvejebragt af coatingapparatet (100) ifølge et hvilket som helst af kravene 1 til 13.

DRAWINGS

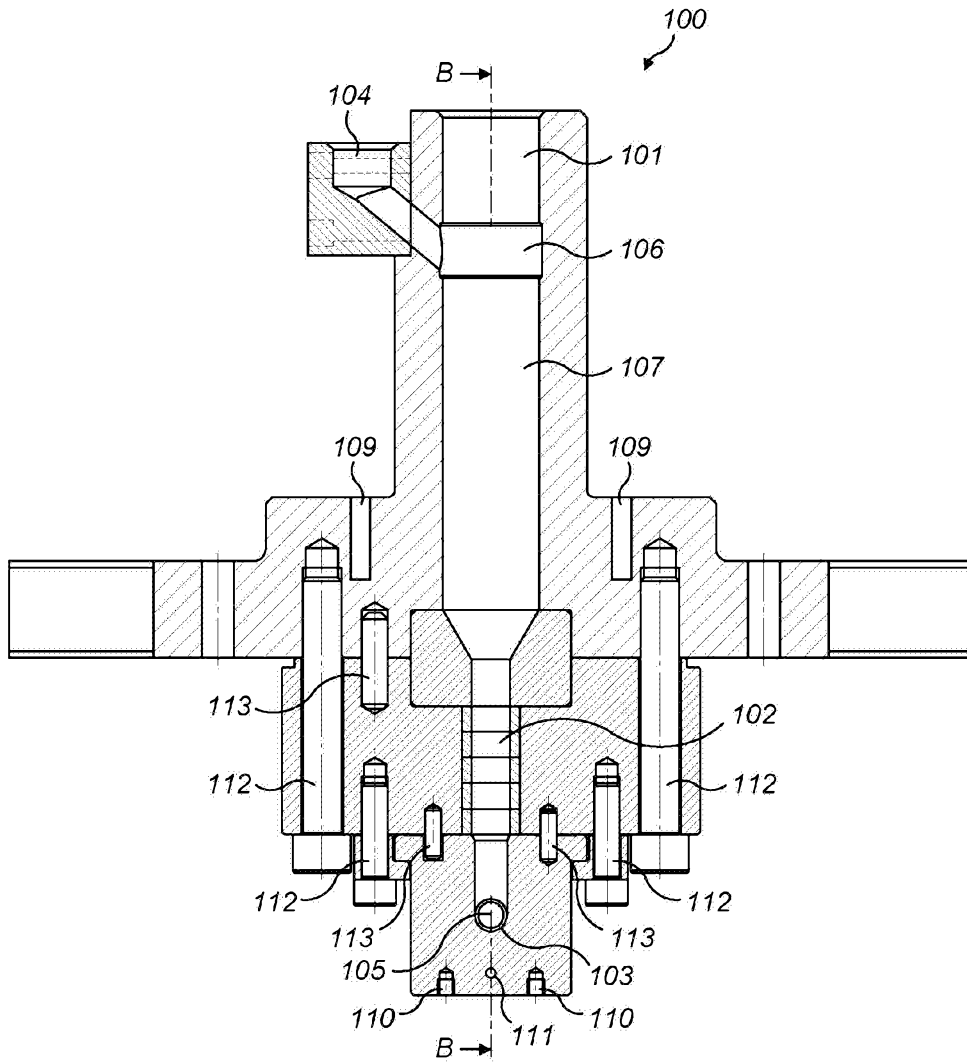

FIG. 1

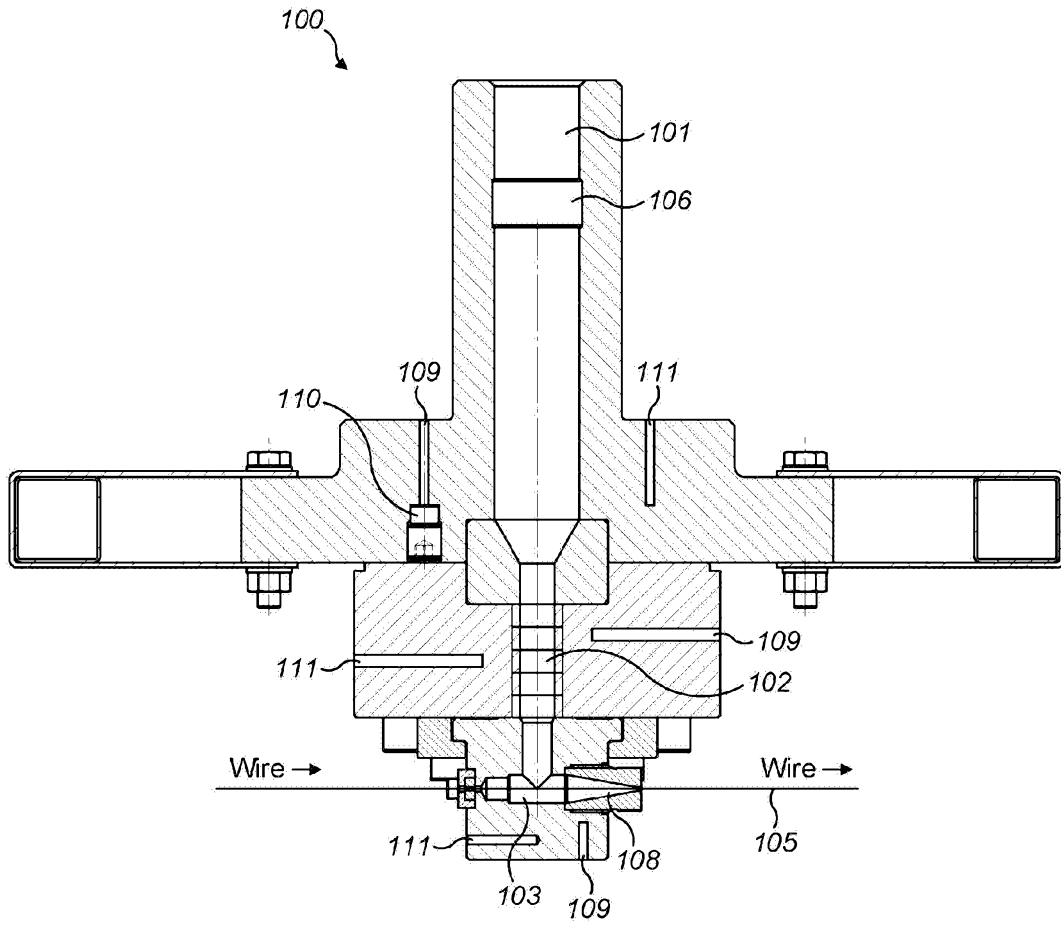

FIG. 2

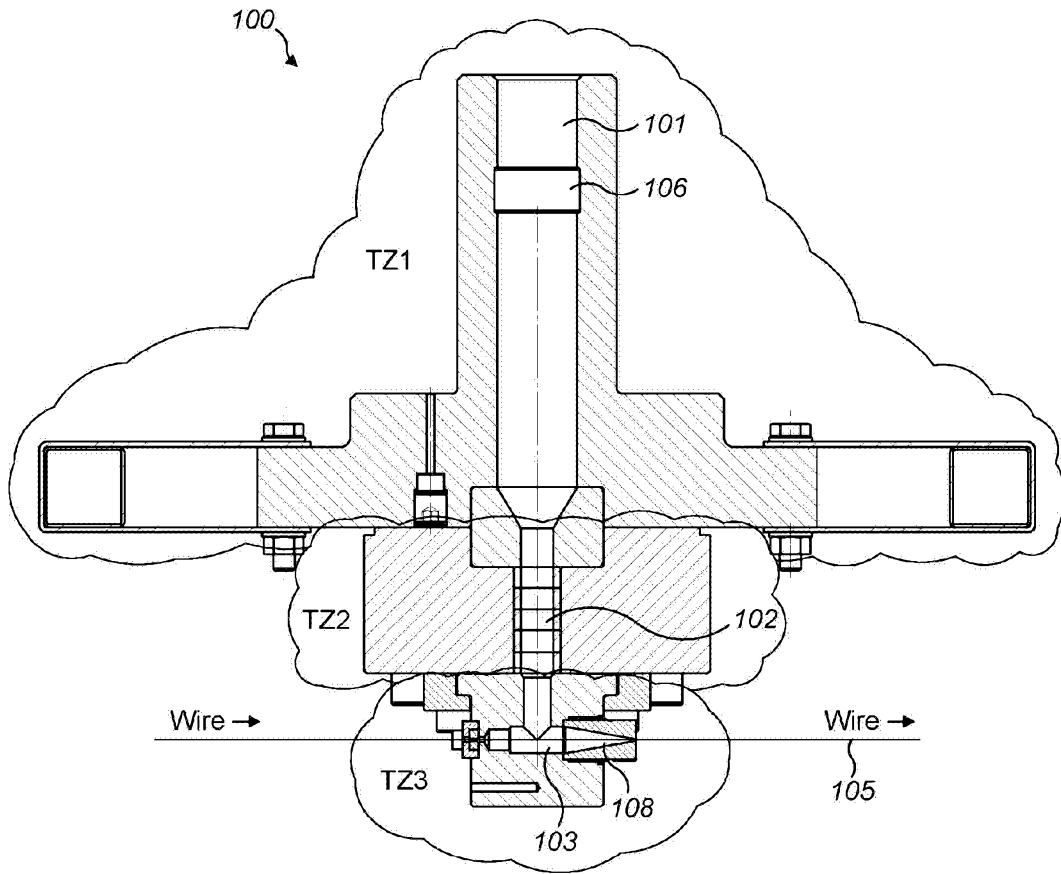

FIG. 3

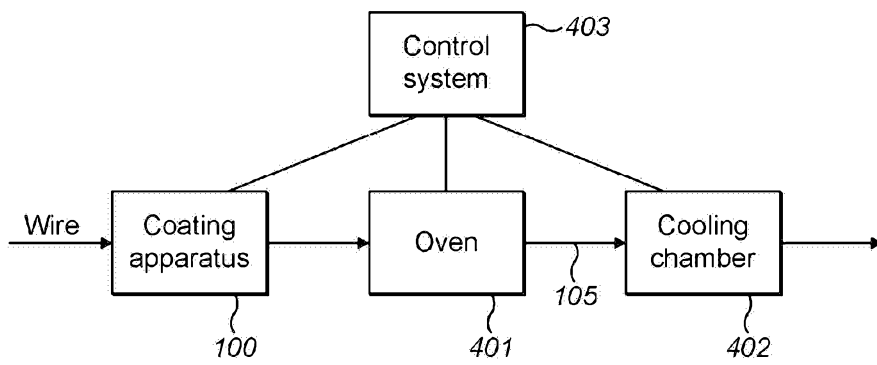

FIG. 4

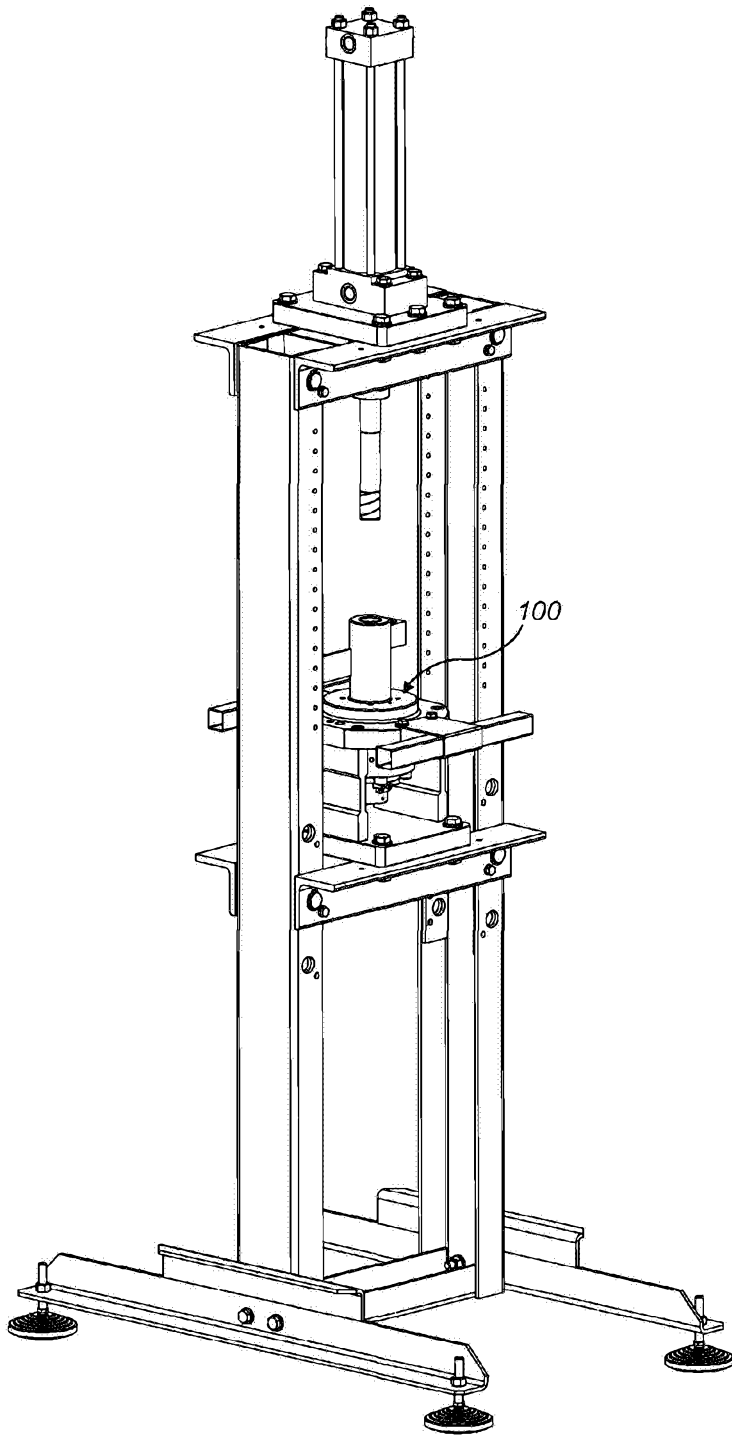
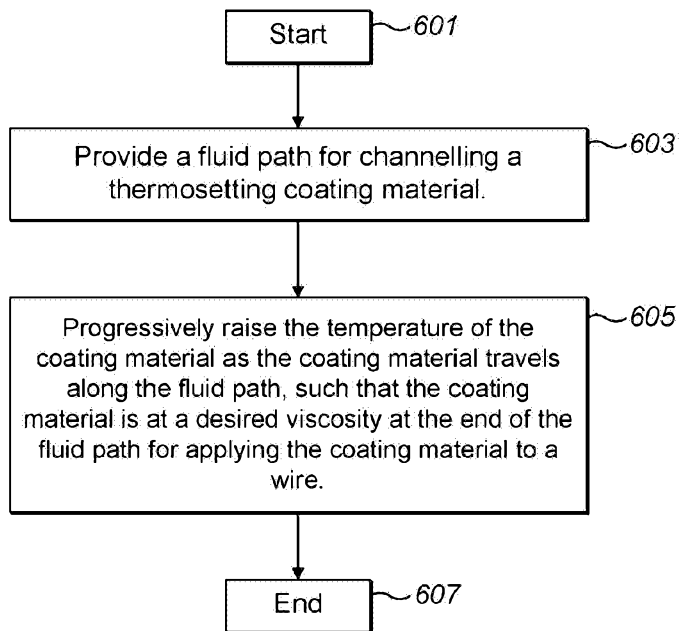

FIG. 5

**FIG. 6**