

T. BENT.
Cooking Stove.

No. 3,613.

Patented June. 5, 1844.

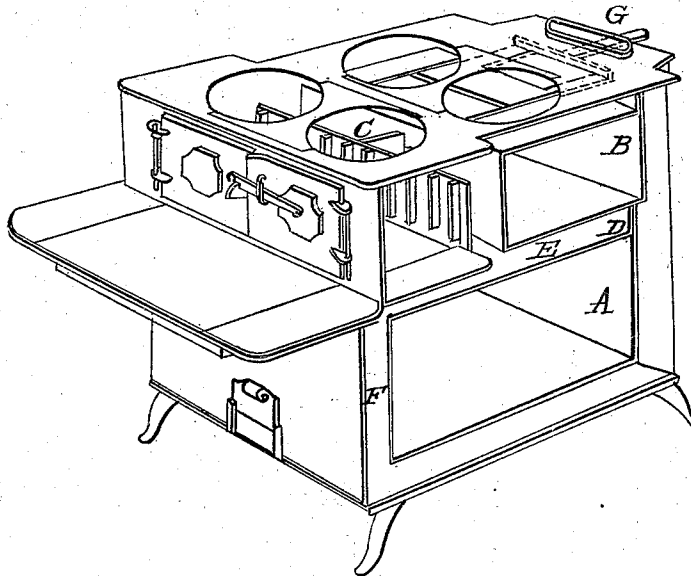

UNITED STATES PATENT OFFICE.

THOMAS BENT, OF NEW YORK, N. Y., ASSIGNOR TO WM. & R. P. RESOR, OF CINCINNATI, OHIO.

COOKING-STOVE.

Specification of Letters Patent No. 3,613, dated June 5, 1844.

To all whom it may concern:

Be it known that I, THOMAS BENT, late of Cincinnati, in the county of Hamilton and State of Ohio, now of the city and county of New York, have made a new and useful Improvement in the Manner of Constructing Double-Oven Cooking-Stoves; and I do hereby declare that the following is a full and exact description thereof.

10 In my stove there are two ovens, one of them situated above the other. The lower oven with its flues, occupies the whole space between the front and back plates of the stove, and the upper oven occupies that part
15 of the stove which is immediately in the rear of the fire chamber. In these respects my stove resembles several others that have been previously constructed; but it differs from all those which have come under my
20 examination in the arrangement of the flues by which said oven are heated; there not being any portion of the draft of heated air from the fire chamber allowed to pass between the bottom of the upper, and the
25 top of the lower oven, the space between them, which in other stoves that are similar to this in the location of the ovens, constitutes a flue space, being in my stove used as a heated air chamber only, the draft being
30 prevented from passing through it by means of a partition closing it at its rear end. By this arrangement it has been found that the bottom of the lower oven is more perfectly heated than in other double oven stoves;
35 while the air chamber is perfectly effective in heating that of the upper.

The accompanying drawing represents my stove with one of its sides removed for the purpose of showing the arrangement of the
40 flues.

A, is the lower, and B, the upper oven. C, is the back plate of the fire chamber, over

which the draft from the fire passes; and descending in the flue-space between this and the lower oven it comes into contact 45 with the upper plate of the latter; but it does not pass between the two ovens, there being a partition at D, which closes the space E, so as to prevent all draft through it, while it is still left as a receptacle for 50 heated air. The draft from the space at the back of the fire chamber in consequence of the foregoing arrangement is forward, immediately under said chamber, then down through the space F, and under the lower 55 oven, to the rear end of the stove, and up to the exit pipe G.

There is a damper, shown by dotted lines, which is situated within the space between the upper plate of the stove, and the top 60 oven plate, by means of which a direct draft from the fire chamber to the exit pipe may be established; and this is to be done when the fire is first lighted, or when the ovens 65 are not to be used. This damper does not differ in its form or action from such as are in common use.

Having thus fully described the manner in which I construct my cooking stove, what I claim therein as new, and desire to secure 70 by Letters Patent, is—

The manner in which the flue spaces therein are arranged and governed, so as to convert that part which is usually employed as a flue space between the two ovens, into a 75 heated air space, by means of the permanent partition D. The whole arrangement of the flues and their combination with the other parts being such as is herein described and represented.

THOMAS BENT.

Witnesses:

A. WRIGHT,
AMHERST WRIGHT, Jr.