

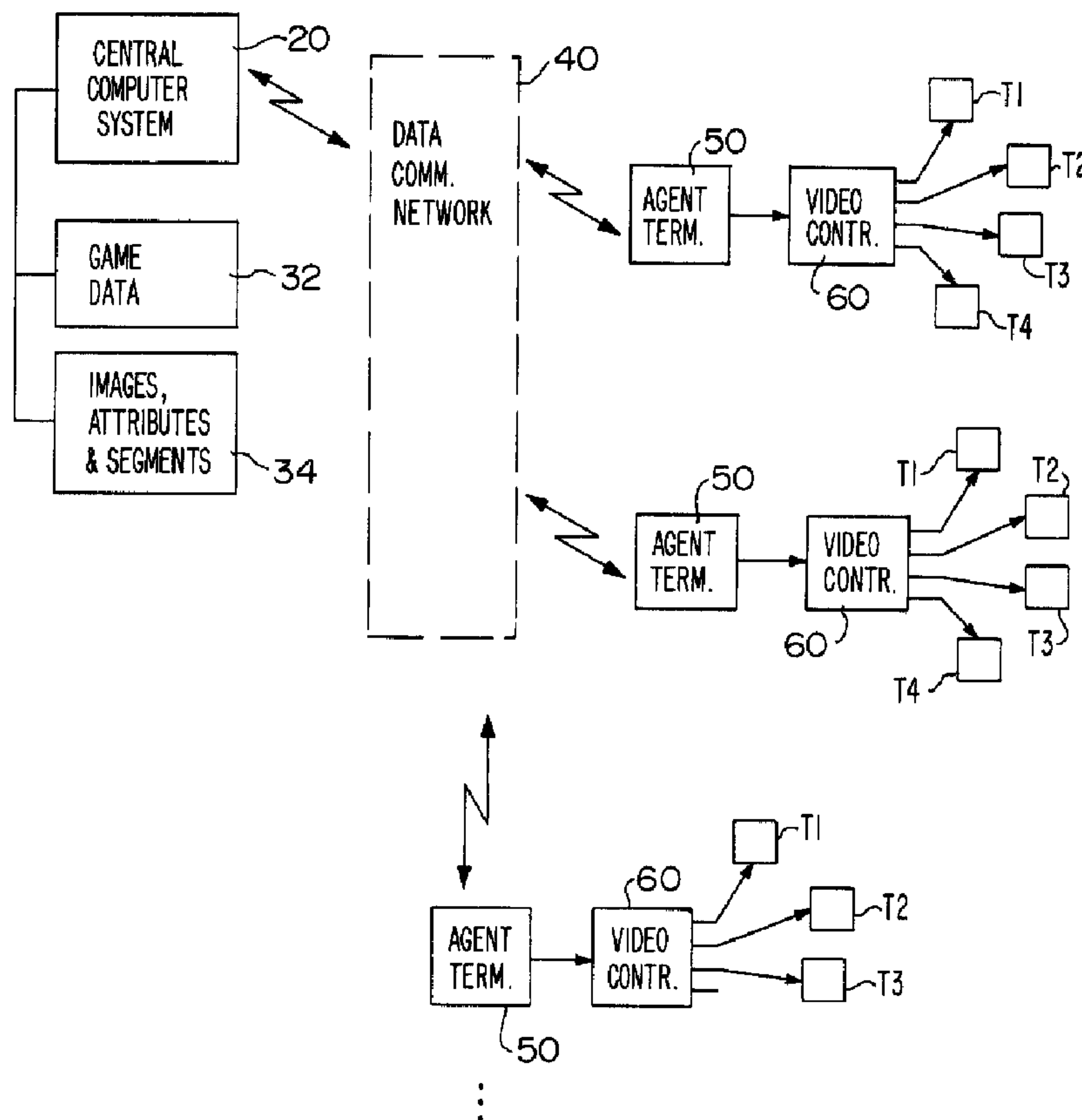

(22) Date de dépôt/Filing Date: 1992/06/26
 (41) Mise à la disp. pub./Open to Public Insp.: 1992/12/29
 (45) Date de délivrance/Issue Date: 2003/01/28
 (30) Priorité/Priority: 1991/06/28 (722,918) US

(51) Cl.Int.⁵/Int.Cl.⁵ G09G 5/36
 (72) Inventeurs/Inventors:
 WASTI, HAMID A., US;
 MEYERS, KRISTIN R., US
 (73) Propriétaire/Owner:
 GTECH CORPORATION, US
 (74) Agent: ROBIC

(54) Titre : CONTROLEUR D'AFFICHAGE VIDEO COULEUR POUR JEUX A JOUEURS MULTIPLES
 (54) Title: COLOR VIDEO DISPLAY CONTROLLER FOR MULTI-PLAYER GAMING SYSTEMS



(57) Abrégé/Abstract:

A display controller includes a digital processor adapted for data communication with a central computer, for controllably downloading alphanumeric data and one or both of image attribute data and complete or partial screen images to be displayed on unmodified standard commercial television receivers. Data memory and program memory are coupled to the digital

(57) Abrégé(suite)/Abstract(continued):

processor, which stores image formatting data or complete images. Programmable logic circuits are coupled to the data output of the digital processor, and in conjunction with the digital processor convert the attributes presented on the data output of the digital processor into a pixel data field wherein each pixel is encoded to one of a number of available color combinations. A color palette converts the pixel field into RGB data. A video encoder takes the RGB data and modulates a subcarrier signal to provide a composite video output. The display controller is preferably part of a networked gaming system with a central computer system managing entry validation and/or selection or crediting of winning entries in a wagering game having numerous players. Distributed agent terminals in data communication with the central computer system manage input of player data and issue of player entries as point of sale terminals under supervisory control of the central computer. A plurality of standard commercial television receivers are coupled respectively to the video buffers, and simultaneously display the image in conjunction with the respective agent terminals, thereby displaying game data to numerous players at retail locations.

COLOR VIDEO DISPLAY CONTROLLER FOR MULTI-PLAYER GAMING SYSTEMS

Abstract of the Disclosure

5 A display controller includes a digital processor adapted for data communication with a central computer, for controllably downloading alphanumeric data and one or both of image attribute data and complete or partial screen images to be displayed on unmodified standard commercial television receivers. Data memory and program memory are coupled to the digital processor, which stores image formatting data or complete images. Programmable logic circuits are coupled to the data output of the digital processor, and in conjunction with the digital processor convert the attributes presented on the data output of the digital processor into a pixel data field wherein each pixel is encoded to one of a number of available color combinations. A color palette converts the pixel field into RGB data. A video encoder takes the RGB data and modulates a subcarrier signal to provide a composite video output. The display controller is preferably part of a networked gaming system with a central computer system managing entry validation and/or selection or crediting of winning entries in a wagering game having numerous players. Distributed agent terminals in data communication with the central computer system manage input of player data and issue of player entries as point of sale terminals under supervisory control of the central computer. A plurality of standard commercial television receivers are coupled respectively to the video buffers, and simultaneously display the image in conjunction with the respective agent terminals, thereby displaying game data to numerous players at retail locations.

10

15

20

25

COLOR VIDEO DISPLAY CONTROLLER FOR MULTI-PLAYER GAMING SYSTEMS

Background of the Invention1. Field of the Invention

The invention relates to the field of video displays, especially those included in wagering game systems associated with retail lottery agent terminals. The invention provides a display system wherein a data processor controls the generation of a composite video signal from image data and/or image attribute data coupled to modify a signal transmitted to a plurality of standard commercial television receivers which need not be modified. Means are included for formatting and displaying changeable graphic screens, and alphanumeric data and graphical image segments such as logos and messages over backgrounds, enabling a whole or partial image or series of images to be displayed on a number of large screen television receiver displays at a fraction of the cost of a computer video monitor.

2. Prior Art

Computer systems adapted to display data on one or more video monitors are known. Typical video monitors for computer systems are relatively high performance devices as compared to commercial televisions. High speed or high capacity interfaces for converting high resolution binary pixel data to RGB or composite video signals are needed, and the deflection circuits are generally adapted for a higher degree of resolution and convergence than is necessary for display of moving scenes of the type broadcast by commercial television stations.

Resolution and convergence demands are relatively greater for larger displays, and video monitors for computer systems therefore are normally small. Although it is possible to provide a large format video monitor for a computer system, the added complexity of the circuitry is such that the display is prohibitively expensive for many uses. For example, the cost of a sixteen inch video monitor may be approximately equal to the cost of a sixteen inch commercial television receiver. However, a nineteen inch video monitor may cost three times as much as a nineteen inch commercial television receiver, and a twenty-five inch video

monitor may cost as much as ten times as much as the same size of commercial television receiver.

A typical video monitor for computer data is coupled to a workstation, and displays information to the operator of the workstation. In such an environment there is no need for a large format display, and in fact a large display can be less comfortable for viewing by the operator sitting in front of the display than a smaller one because the larger display may require the viewer to turn his or her head. It is known, however, to provide a composite video output, and optionally a radio frequency modulator, for coupling the display output of a computer to a commercial television receiver. This arrangement is typically for low end home computers, wherein the computer controls the display for operating a video game or the like on a home television. Such devices are arranged to drive a single commercial television with a pre-formatted, stored display field, often including the display of movable elements (sometimes called sprites) under control of the computer and its operator. Although given sufficient data capacity the video game can store a plurality of images such as the individual playing backgrounds through which the player advances in the video game, the display fields themselves are not changeable and simply form a background for the movable elements. Furthermore, there is no need to employ more than one display device because the operator of the computer (e.g., player of the video game) can only look at one display at a time.

A different form of display system is known in connection with data displays to be viewed simultaneously by a number of viewers at various locations. Such systems are well known, for example, in connection with display of flight information in airport terminals. The data displayed is limited to columnar displays of alphanumeric characters according to digital data received from a central computer system. Characters are displayed by each display monitor according to the data which is transmitted to the display terminal. There is no capability of variably formatting a video signal for a plurality of commercial television receivers coupled to a local controller which generates a composite video signal in

a changeable manner.

Certain games, such as keno, are played using some form of display sign or the like for keeping a number of viewers apprised of the progress of the game. In keno, players choose a predetermined number of play entry numbers from a series of available entries in a lot, and then a series of numbers are drawn one at a time to determine winners. Players whose entries match a certain number of those drawn are winners. Similarly, in lotto games, winning is determined by matching a predetermined number of successively drawn numbers. Prompt and wide display of the numbers drawn to determine the winners is an important aspect of these and other games, is exciting for the players, and encourages players to enter. It is known to provide an electronic sign having lights to designate numbers drawn in a keno game, and lottery agencies frequently televise the drawing of lotto numbers. Of course a fixed sign is not at all variable in format, and a television program is not variable in format under control of a local video controller.

Another example of a display system used in connection with games involves display of bowling information on overhead displays. The display in this case is also unchangeably formatted in the form of a background grid delineating the players and frames. Each lane or pair of lanes has interactive input means for its single display terminal, located above the respective bowling lane.

It would be advantageous to provide a display system which can truly be formatted under computer control for display of data to a plurality of viewers. For use by lottery agents, a video controller for this purpose should be controllable at least partly by the lottery central computer and in order to be cost effective as well as accessible to numerous players the controller must be arranged to operate a plurality of commercial television receivers. By providing a display system which can incorporate not only alphanumeric data and stored backgrounds, but also can reformat sections of the display, for example to include graphical images such as logos and to reposition alphanumeric data in the reformatted image, a versatile display arrangement is provided.

2072480

4

The simultaneous display of alphanumeric data, graphical segments and backgrounds is particularly applicable to a wagering system, wherein the display keeps the players apprised of information respecting the game, allows controlled display of not only successive games of one type or successive display formats relating to a game, but also can display a progression from a game using one display format and relating to one set of data, to a game using a completely different format and relating to a different set of data.

Summary of the invention

It is an object of the invention to provide a versatile and inexpensive display controller for operation of a plurality of standard commercial television receivers displaying changeable and reformattable information.

It is also an object of the invention to incorporate in a multiple viewer display system the ability to handle logos and similar graphical segments, and specifically digitized images, displayed in changeable format under computer control.

It is another object of the invention to enable at least limited animation in an image displayed in such a multiple viewer arrangement.

It is another object of the invention to provide driving means for a plurality of standard commercial television receivers, especially with large screen displays, for use by the customers of a retail gaming operation in monitoring the progress of one or more wagering games.

It is a further object of the invention to provide a terminal device for coupling in data communication with a central lottery computer system, and with a lottery agent terminal, operable under control of the central computer system and the agent terminal to format and generate in composite video a mixed display of data at the initiation of one of the central computer system and the agent terminal, for displaying to a plurality of lottery players information of interest to the players in connection with at least one lottery game in progress.

According to the present invention, there is provided a display controller, comprising:

a digital processor having means for data communication with an external system, operable to supply encoded data to the digital processor, the data relating to an image to be

5a

displayed under control of the digital processor;

data memory means and program memory means coupled to the digital processor, the data memory means including random
5 access memory for storage of information defining a plurality of attributes of an image to be displayed, under control of the digital processor, and the digital processor being operable to convert said attributes to image data;

a control logic circuit coupled to the digital processor,
10 operable to feed said image data into means for storing a pixel field;

video encoder means coupled to the control logic circuit, for converting the pixel field into a composite video output;

a plurality of video buffers coupled to the composite
15 video output of the video encoder means, operable to transmit video information in a standard commercial television format; and

a plurality of standard commercial television receivers coupled respectively to the video buffers, and operable to
20 display said image.

Preferably, the display controller includes a digital processor adapted for data communication with a central computer, for controllably downloading alphanumeric data and one or both of image attribute data and complete or partial
25 screen images to be displayed on unmodified standard commercial television receivers. Data memory and program memory are coupled to the digital processor, which stores image formatting data or complete images. Programmable logic arrays are coupled to the data output of the digital
30 processor, and in conjunction with the digital processor convert the attributes

presented on the data output of the digital processor into a pixel data field wherein each pixel is encoded to one of a number of available color combinations. A color palette converts the pixel field into RGB data. A video encoder takes the RGB data and modulates a subcarrier signal to provide a composite video output. The display controller is preferably part of a networked gaming system with a central computer system managing entry validation and/or selection or crediting of winning entries in a wagering game having numerous players. Distributed agent terminals in data communication with the central computer system manage input of player data and issue of player entries as point of sale terminals under supervisory control of the central computer. A plurality of standard commercial television receivers are coupled respectively to the video buffers, and simultaneously display the image in conjunction with the respective agent terminals, thereby displaying game data to numerous players at retail locations.

The display controller is advantageously embodied using programmable logic arrays for coupling control and data signals from the digital processor to the memory elements, serial communication interface elements for communication with the central computer via the agent terminal, video encoder and the like. Whereas the logic arrays are programmable the controller is readily set up and readily converted to a desired mode of operation, for example for providing programmed sequences of displays, setting up for use of PAL or NTSC television receivers, etc., and accordingly is quite versatile. However, the controller requires a small number of components, and in conjunction with standard unmodified television receivers provides an inexpensive and effective display system which is particularly useful for application to networked wagering games such as lotto, keno and the like.

Brief Description of the Drawings

There are shown in the drawings exemplary embodiments of the invention as presently preferred. It should be understood that the invention is not limited to the illustrated embodiments, in accordance with the disclosure and claims as a whole. In the drawings,

Fig. 1 is schematic diagram illustrating the components of the video controller according to the invention and their interconnection signal paths and busses; and,

Fig. 2 is a block diagram of a networked wagering system according to the invention, including a central computer and a plurality of agent terminals including customer display means.

Detailed Description of the Preferred Embodiments

The video controller 60 of the invention, as shown in Fig. 1, includes a digital processor U1, for example Motorola microcomputer model MC68HC000, in data communication with a communications network via serial communications controller U7, and adapted to control generation of image signals to be displayed on a plurality of unmodified commercial television receivers T1-T4 via their composite video or antenna inputs. The digital processor or CPU U1 is driven by clock circuit Y1, which has a crystal oscillator defining an instruction cycle of 8MHz or $0.12\mu\text{s}$. CPU U1 is coupled to a 23 bit address bus B_A and to a 16 bit data bus B_D , for memory addressing and data exchange with a system read only memory U4 and random access memory U2. The controller requires 64K of RAM and 128K of ROM, and is capable of supporting up to 256K of RAM and ROM using this number of address bus lines. The RAM U2 is shown as a single block, but according to the preferred embodiment includes two 64K RAM ICs. Model numbers of specific integrated circuits of a preferred embodiment of the invention are shown throughout Fig. 1.

Two programmable logic arrays U5 and U6 are coupled to CPU U1 and to the system memories U2 and U4 for decoding CPU signals to enable bus data transfers and other functions, as well as to signal the CPU U1 at its inputs. Programmable logic array U5 is arranged to decode signals to generate interrupts to CPU U1, such as an interrupt generated from an end-of-frame or similar signal from the serial communications controller U7, etc., and provides bus error signals in the event of an attempt to access an invalid address. Logic array U5 generates chip enable signals for selecting ROM U4 or one of the individual chips of RAM U2, and also for selecting a read function for memories U2 or U4 or a write function for memory U2. These functions are selected based on outputs of CPU U1 during bus cycles defined by the outputs of CPU U1. Additionally, logic array U5 is arranged to check for acknowledge signals on the bus in response to data transfers for all elements coupled to the system busses except the video RAM U13, which is discussed hereinafter.

ROM U4 contains programmed instructions to be executed by CPU U1, and can contain data value constants and the like. Preferably, ROM U4 also stores constants to be downloaded into additional elements of video controller 60 upon initiation of the system, for example for programming Xilinx field programmable gate array U20, which generates timing and control signals for operating the video RAM U13, video encoder U21, color palette U19 and data latch U17. It is also possible to arrange to have the programming for the Xilinx programmable array U20 varied during operation under control of CPU U1 and/or to obtain coding for such elements by downloading from a remote location along the serial communications link of serial controller U7, buffer U11 and communications port P1.

In addition to addressing the system memories U2 and U4, CPU U1 uses the system address bus B_A to address the serial communication controller U7 and the Xilinx programmable array U20. By reading and writing appropriate data to the address and data busses B_A and B_D , and in conjunction with control signals from programmable arrays U5 and U6, the CPU U1 coordinates operation of controller 60.

The system ROM U4 and RAM U2 can be used to store instructions respecting images to be displayed on the television receivers T1-T4, and in particular to store data representing attributes of certain of the images to be displayed. Additionally, controller 60 is arranged to receive data from the communication network including additional and/or alternative attributes to be displayed by controller 60, as well as entire image fields or segments of image fields to be inserted into the image otherwise defined by stored attribute data.

Communications along the serial communication path of serial controller U7, buffer U11 and port P5 are bidirectional. Programmable logic array U8 stores an identification code unique to the particular controller 60, such as a serial number, for use by a remote central computer communicating with the controller 60. Data received at controller 60 along the communication path can include an encoded identification code for comparison with the code stored in logic array U8, thus allowing the remote computer to

address individual controllers 60 in this manner. Alternatively, the identification code can be transmitted to the remote computer together with acknowledgement of a transmission or with other data, allowing the remote computer uniquely to determine the source of a transmission it receives on communication channels open to a plurality of controllers 60. In a network including such identification it is not necessary for all the controllers to be identical or to be operated identically because the remote computer can tailor transmissions to the controller, and interpret transmissions received from the controller, in accordance with data stored at the remote computer relating to the character of the controller or the establishment in which it is located.

The serial communications controller U7 is coupled to buffer U11, which is bidirectionally operable to interface between TTL levels on the controller side of buffer U11, and standard communications formats at the communication port P5, coupled to the communication network. Although various buffers are possible for providing such an interface, the preferred embodiment uses input and output sections for buffer U11 which convert between TTL and RS422 standards. One of the inputs to serial communications controller U7, generated by the presence or absence of jumper E1, selects whether the controller is set for processing images according to the NTSC format or the PAL format, allowing incoming frame information to be decoded accordingly, and prompting CPU U1 upon initiation to download to the Xilinx programmable array the correct program.

Data for display as received over the serial communication link or as generated wholly or partly by CPU from image attribute data stored in memory elements U2 and/or U4 is coupled from the system data bus B_D to video RAM U13 under addressing control of the Xilinx programmable array U20. The Xilinx circuit handles generation of video control signals and acts as a bus master for the video address bus B_{VA} and video data bus B_{VD} . A video timing section of the programmable array U20 generates sequential pixel addresses for video RAM U13, and horizontal and vertical sync and blanking pulses for video encoder U21.

The programmable array U20 is coupled to a phase locked loop U23, responsive to the output of colorburst clock U26, for defining the video clock at four times the video subcarrier frequency determined by the burst clock. It is also possible to generate a video clock at four times the video frequency, coupled to programmable array U20, and to count down the video subcarrier frequency from the video clock using a counter in programmable array U20. Pixel addressing is handled by the programmable array U20 and is multiplexed with the system address bus B_A for time shared access to the video data with CPU U1. In particular, an internal counter in the programmable array U20 addresses the next pixel address via video address bus B_{VA} for two successive cycles of the video clock, and then system address bus B_A determines the video address for the next six video clock cycles. At the end of the two cycle period the pixel data is latched in the buffers that feed the pixel information through to the color palette U19.

The system clock Y1 and the burst clock U26 are asynchronous. Programmable logic circuits U5 and U6, which control interrupts and bus arbitration, will force digital processor U1 into a wait state if processor U1 attempts to access the video RAM outside of the predetermined time divisions allotted to it. Data transfer proceeds during the next cycle of time divisions allotted to processor U1.

During the six cycles of the video clock wherein the system address bus addresses the video data, the CPU U1 can manipulate the data in video RAM U13 in the same manner as it manipulates the system memory U2, and thus can effect changes in the image to be displayed. For example, image attributes stored in RAM U2, ROM U4 or downloaded along the serial communication path, such as the address or position and nature of lines, figures, alphanumeric characters and the like to be inserted into the display, can be decoded and entered into the video RAM data. Alternatively, a full frame or a segment of a full frame such as a logo or other image segment can be entered into the video RAM under control of CPU U1. Access of CPU U1 to video RAM U13 is quick enough to accomplish at least minimal animation in the image displayed. The particulars

of the data entered in video RAM U13 by CPU U1 can be received from the serial communication link of controller U7 and stored in system RAM U2, or can be generated by programmed operations of CPU U1 in response to binary data received, stored routines in ROM U4, etc.

The illustrated embodiment is arranged to generate NTSC composite video signals. The timing of NTSC and PAL video signals is different, and the programming of the Xilinx programmable array can be arranged to accommodate either format. The Xilinx coding for operation of programmable array U20 is downloaded from system memory by the CPU U1 upon startup, for example from ROM U4. Jumper E1 on the circuit card sets a particular board for operation in the PAL or NTSC format such that CPU loads programmable array U20 appropriately. The jumper can also to effect other differences in the character and timing of the video signals for producing an NTSC or PAL output.

Color palette U19 includes a look up table addressed by the pixel data and by the programmable array U20. Under control of the programmable array U20 the color palette U19 decodes the four bit pixel data to select a particular proportion of each of the red, blue and green outputs, and to produce analog levels on the RGB outputs coupled to the video encoder U21. Whereas there are four bits available to each pixel, one of sixteen distinct colors can be selected at any one time. However, the correspondence of the sixteen possible pixel data values with a larger number of available color proportions stored in color palette U19 can be changed, providing additional selectable color proportions. The programmable array varies the RGB data associated with a given pixel data value by modifying addressing in the look up table as often as every horizontal video scan line. In this manner the sixteen pixel data values are remapped to allow many combinations of colors of pixels in the display.

The look up table in the color palette can be downloaded from the video RAM U13, from data received on the serial communication link, or can be loaded from static memory from system RAM U2 or system ROM U4. The look up table can contain, for example, sixteen 12-bit color lookup registers, each containing a definition of a

distinct combination of red, blue and green color levels, allowing selection of any of 4,096 available colors. Of course the number of available colors can be changed by varying the number of available color definition bits. The red, blue and green data values each are each coupled, for example, to a four bit digital to analog converter in the color palette circuit U19, thereby providing sixteen discrete levels of intensity for each particular color or 4,096 (16^3) distinct possibilities.

The RGB analog levels are coupled to video encoder U21, which modulates the subcarrier signal with the analog data from the color palette RGB outputs and with the synchronizing pulses generated by programmable array U20, thus generating a composite video signal which is readily displayed on an unmodified commercial television receiver T1-T4. A plurality of video buffers, comprising follower amplifiers and impedance matching circuits, separately drive the signals at the output ports P1-P4. While an indefinite number of video buffers and television receivers could be included, four have been shown for purposes of illustration.

Whereas the output of the circuit according to the invention is generated in a standard composite video format, the television receivers T1-T4 normally can be simply plugged into the signal lines coupled to output ports P1-P4, using standard coaxial cable. In the event that one or more of the television monitors lacks a composite video input, an RF modulator can be inserted between the output port and the antenna input of the respective receiver, such that the video signal can be decoded and displayed using the same circuits which otherwise process commercial television signals.

Fig. 2 illustrates the application of the invention to a gaming network of the type run by many state lottery commissions. A central lottery computer 20 in data communication with distributed agent terminals 50 over a data communication network 40 manages the sale of player entries to customers. The agent terminals are basically point of sale terminals, but may have various functions such as reading of marked entry forms, reading of issued tickets for comparing them to winning ticket data, etc. The central lottery computer typically handles entry validation

functions by storing information relating to individual entries sold, for later comparison with the information on issued entries which are presented by the customers as winners. The central computer is coupled to a game data memory means 32 for storage of this information.

According to the invention the central computer also has additional memory capacity for storage of images, encoded attributes of images, or partial screen segments of images which can readily be downloaded to the agent terminals 50 over the data communication network. Some or all of the agent terminals in the data communication network are coupled to video controllers 60, which in accordance with the foregoing description are coupled to standard commercial television receivers located at or near the location of the agent terminals, for displaying game data to customers. The agent terminals may communicate with the communication port P5 of a display controller according to the invention, or may incorporate a display controller coupled to a communication port already provided in the agent terminal for bidirectional transmission of game data. The agent terminals simply pass received image data, image attribute data or image segment data to the respective video controller. Additionally, the agent terminals can add command data to the data received from the central computer 20, for example allowing the agent to select the sequence of available screens which the video controller 60 will display.

The gaming system of the invention is particularly useful in certain forms of games, but is also generally useful as a means for conveying game information and promotional information to customers. In connection with a keno game or the like, a large number of players may be interested in the same game at the same time. For example as successive winning entries are drawn in a keno game the players wish to compare the winning numbers with their list of entry numbers. The invention allows a plurality of television receivers to be distributed around the agent terminal location. The image screens displayed can be modified by CPU U1 to update them by insertion of additional winning numbers as they

are drawn. The image screens can readily accommodate segments such as logos, late breaking news, photographs or artwork on the game or other subjects added to a basic presentation, and/or variation of the basic presentation to keep it interesting. The variations can include animation, blinking and/or dynamic transformation of colors, etc. These characteristics are available without substantial expense due to the use of a commercial television receiver as the ultimate display means.

The invention having been disclosed in connection with exemplary embodiments and particular circuits, variations on the embodiments or circuits will now become apparent to persons skilled in the art. Whereas the invention is subject to such variations within the scope and spirit of the invention and its reasonable equivalents, reference should be made to the appended claims rather than the foregoing specification to assess the scope of the invention in which exclusive rights are claimed.

I claim:

1. A display controller, comprising:

a digital processor having means for data communication with an external system, operable to supply encoded data to the digital processor, the data relating to an image to be displayed under control of the digital processor;

data memory means and program memory means coupled to the digital processor, the data memory means including random access memory for storage of information defining a plurality of attributes of an image to be displayed, under control of the digital processor, and the digital processor being operable to convert said attributes to image data;

a control logic circuit coupled to the digital processor, operable to feed said image data into means for storing a pixel field;

video encoder means coupled to the control logic circuit, for converting the pixel field into a composite video output;

a plurality of video buffers coupled to the composite video output of the video encoder means, operable to transmit video information in a standard commercial television format; and,

a plurality of standard commercial television receivers coupled respectively to the video buffers, and operable to display said image.

2. The display controller according to claim 1, further comprising a color palette circuit coupled to the control logic circuit and the video encoder means, data in said pixel field identifying distinct color combinations defined by the color palette, for conversion by the video encoder means.

3. The display controller according to claim 2, wherein the data in the pixel field encodes a smaller number of distinct color combinations than are available in the color palette, and wherein the control logic circuit is operable to remap correspondence of the data in the pixel field to said distinct color combinations of the color palette.

4. The display controller according to claim 3, further comprising a burst clock generator operable to provide a color subcarrier signal, and wherein the color palette includes digital to analog conversion means for producing red, blue and green output signals, and the video encoder means includes a modulator operable to modulate the color subcarrier signal with the red, blue and green output signals.

5. The display controller according to claim 1, further comprising a video RAM for storage of data in the pixel field, and wherein the video RAM is multiplexed for time shared access by the control logic circuit, for feeding the data in the pixel field to the video encoder means, and by the digital processor, for modifying data in the video RAM.

6. The display controller according to claim 5, wherein the control logic circuit controls access to the video RAM, and further comprising a video clock generator for the control logic circuit and a system clock generator for the digital processor, access to the video RAM by the digital processor being available during predetermined time divisions of the video clock generator.

7. The display controller according to claim 6, further comprising a color subcarrier generator for generating a color burst frequency signal, and wherein the video clock generator is coupled to the color subcarrier generator and is operable to provide a video clock signal at a multiple of the color burst frequency signal.

8. The display controller according to claim 7, wherein the color subcarrier generator and the system clock generator are asynchronous, and further comprising bus control means forcing the digital processor into a wait state upon access to the video RAM attempted outside of the predetermined time divisions.

9. The display controller according to claim 1, further

comprising a system address bus, a system data bus, a video address bus and a video data bus, and wherein the system address bus is coupled to the data memory means, program memory means and control logic circuit for selecting operations under control of the digital processor, and the video address bus and video data bus are coupled to the control logic circuit for feeding pixel data to the video encoder means.

10. The display controller according to claim 9, further comprising a video RAM coupled between the control logic circuit and the video encoder means, and wherein the control logic circuit is arranged for time shared access of the digital processor to pixel data in the video RAM, for modifying an image to be displayed.

11. The display controller according to claim 10, wherein the digital processor is operable to download to the video RAM at least segments of the image to be displayed.

12. The display controller according to claim 11, wherein the digital processor is also operable to modify the image to be displayed according to at least one routine selected by said attributes.

13. The display controller according to claim 11, further comprising a serial communication controller coupled to the digital processor for data communication with a remote computer, and wherein the digital processor is operable to receive from the serial communication controller and to insert into the image to be displayed at least one of alphanumeric characters, display segments and full displays.

14. The display controller according to claim 9, further comprising a serial communication controller coupled to the digital processor via the system address bus and the system data bus, and wherein the digital processor is operable to receive from the

serial communication controller and to insert into an image to be displayed at least one of alphanumeric characters, display segments and full displays.

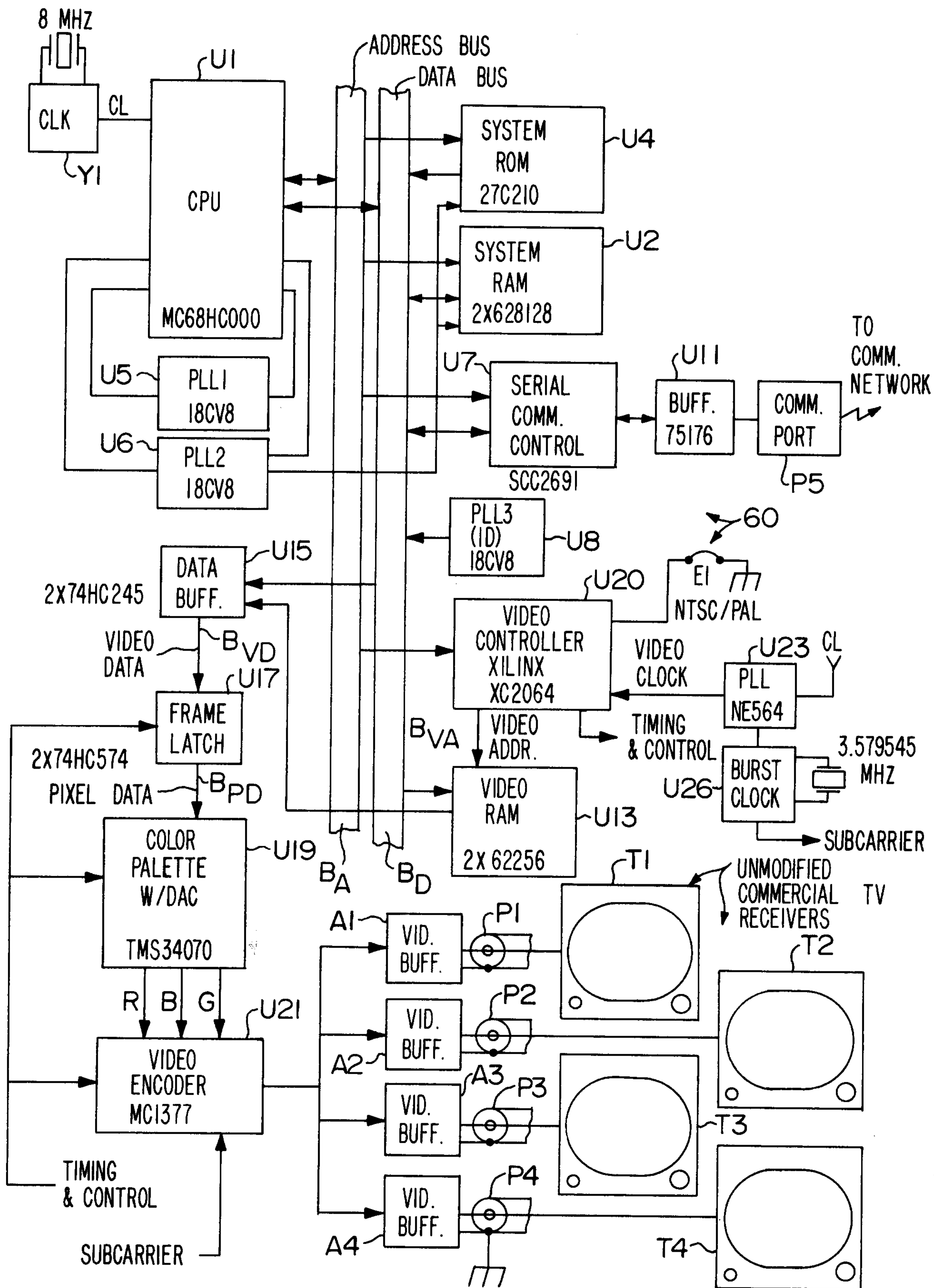

FIG. 1

