

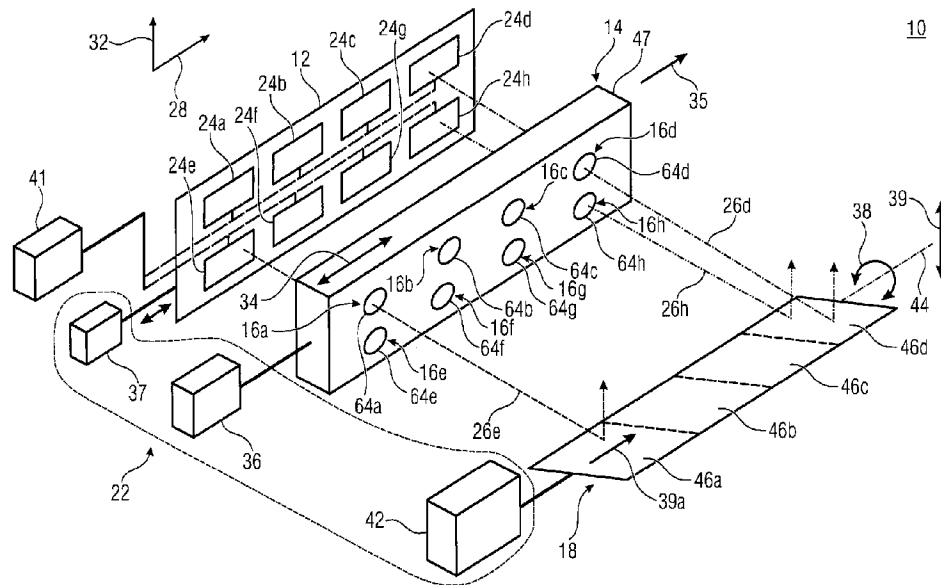

(86) Date de dépôt PCT/PCT Filing Date: 2018/03/01
 (87) Date publication PCT/PCT Publication Date: 2018/09/13
 (45) Date de délivrance/Issue Date: 2022/02/15
 (85) Entrée phase nationale/National Entry: 2019/09/09
 (86) N° demande PCT/PCT Application No.: EP 2018/054997
 (87) N° publication PCT/PCT Publication No.: 2018/162304
 (30) Priorité/Priority: 2017/03/10 (DE10 2017 204 035.1)

(51) Cl.Int./Int.Cl. *G02B 27/64* (2006.01),
G02B 13/00 (2006.01), *H04N 5/232* (2006.01)
 (72) Inventeurs/Inventors:
WIPPERMANN, FRANK, DE;
DUPARRE, JACQUES, DE
 (73) Propriétaire/Owner:
FRAUNHOFER-GESELLSCHAFT ZUR FOERDERUNG
DER ANGEWANDTEN FORSCHUNG E.V., DE
 (74) Agent: SMART & BIGGAR LLP

(54) Titre : DISPOSITIF DE REPRODUCTION MULTIOUVERTURE, SYSTEME DE REPRODUCTION ET PROCEDE DE FOURNITURE D'UN DISPOSITIF DE REPRODUCTION MULTI-OUVERTURE
 (54) Title: MULTI-APERTURE IMAGING DEVICE, IMAGING SYSTEM AND METHOD FOR MAKING AVAILABLE A MULTI-APERTURE IMAGING DEVICE



(57) **Abrégé/Abstract:**

A multi-aperture imaging device includes an image sensor and an array of optical channels, wherein each optical channel includes an optic for projecting a partial field of view of a total field of view on an image sensor area of the image sensor. The multi-aperture imaging device includes a beam-deflecting means for deflecting an optical path of the optical channels, and an optical image stabilizer for the image stabilization along a first image axis by generating a first translational relative movement between the image sensor and the array and the beam-deflecting means and for the image stabilization along a second image axis by generating a second relative movement between the image sensor, the array and the beam-deflecting means. The device includes an electronic image stabilizer for the image stabilization of a first optical channel of the array along the first and the second image axis.

Multi-aperture imaging device, imaging system and method for making available a multi-aperture imaging device

Abstract

5

A multi-aperture imaging device includes an image sensor and an array of optical channels, wherein each optical channel includes an optic for projecting a partial field of view of a total field of view on an image sensor area of the image sensor. The multi-aperture imaging device includes a beam-deflecting means for deflecting an optical path of the optical channels, and an optical image stabilizer for the image stabilization along a first image axis by generating a first translational relative movement between the image sensor and the array and the beam-deflecting means and for the image stabilization along a second image axis by generating a second relative movement between the image sensor, the array and the beam-deflecting means. The device includes an electronic image stabilizer for the image stabilization of a first optical channel of the array along the first and the second image axis.

10

15

Multi-aperture imaging device, imaging system and method for making available a multi-aperture imaging device

5 Description

The present invention relates to a multi-aperture imaging device, an imaging system and a method of providing a multi-aperture imaging device. The present invention further relates to multi-aperture imaging systems having a linear channel arrangement and a small or very small size.

Conventional cameras have an imaging channel that images the entire object field. The cameras have adaptive components that enable a relative lateral, two-dimensional displacement between an objective and an image sensor for realizing an optical image-stabilization function. Multi-aperture imaging systems having a linear channel arrangement consist of several imaging channels that each only capture a part of the object and that contain a deflecting mirror.

It would be desirable to have concepts for multi-channel capturing of object areas or fields of view that enable a compact realization.

Thus, it is the object of the present invention to provide a multi-aperture imaging device and a method of providing a multi-aperture imaging device that enables a compact realization, i.e., having a small installation space, with a high image quality.

One finding of the present invention is to have realized that the above object may be solved by the fact that an optical image stabilization of an image captured by the multi-aperture imaging device may be obtained by a relative movement between the image sensor, an array of optical channels and a beam-deflecting means so that existing components may be used, which enables a compact structure and provides a high image quality. Any deviations between optical channels are additionally balanced by an electronic image stabilizer so that the channel-global optical image stabilization is improved by an electronic correction that is different between optical channels.

According to an embodiment, a multi-aperture imaging device includes an image sensor, an array of optical channels, a beam-deflecting means and an optical image stabilizer. Each optical channel of the array of optical channels includes an optic for projecting a partial field of view of a total field of view on an image sensor area of the image sensor. The beam-deflecting means is configured to deflect an optical path of the optical channels. The optical image stabilizer is configured to provide an image stabilization along a first image axis by generating a first relative movement between the image sensor, the array and the beam-deflecting means, and an image stabilization along a second image axis by generating a second relative movement between the image sensor, the array and the beam-deflecting means. The multi-aperture imaging device includes an electronic image stabilizer for the image stabilization of a first optical channel of the array along the first and the second image axes.

In one embodiment, there is provided a multi-aperture imaging device comprising: an image sensor; an array of optical channels, each optical channel including an optic for projecting a partial field of view of a total field of view on an image sensor area of the image sensor; a beam-deflecting means for deflecting an optical path of the optical channels; and an optical image stabilizer for the image stabilization along a first image axis by generating a first relative movement between the image sensor, the array and the beam-deflecting means and for the image stabilization along a second image axis by generating a second relative movement between the image sensor, the array and the beam-deflecting means; an electronic image stabilizer for the image stabilization along a first optical channel of the array along the first and the second image axis; further implemented for at least one of: wherein the optical image stabilizer is configured to execute the optical image stabilization such that the optical image stabilization for an image of a first of the partial fields of view as reference image is as exact as possible, wherein the electronic image stabilizer is configured to stabilize an image of a second partial field of view based on the reference image of the optical image stabilizer; wherein the optical image stabilizer is configured to stabilize an image of the imaged partial field of view of a reference channel of the optical channels, and wherein the electronic image stabilizer is configured to execute, by means of channel-individual image evaluation of the movement of image details, an image stabilization in a channel-individual manner for optical channels that differ from the reference channel, wherein the multi-aperture imaging device is configured to stabilize the reference channel exclusively in an optical manner; wherein the optical image stabilizer is configured to stabilize an image of the imaged partial field of view of a reference channel of the optical channels, and wherein the

electronic image stabilizer is configured to execute an image stabilization in a channel-individual manner and differently from each other for optical channels that differ from the reference channel, wherein the multi-aperture imaging device is configured to stabilize the reference channel exclusively in an optical manner; wherein the electronic image stabilizer is configured to execute, by means of channel-individual image evaluation of the movement of image details, an image stabilization for each optical channel in a channel-individual manner in order to correct channel-individual imaging errors; wherein the electronic image stabilizer is configured to execute an image stabilization for each optical channel in a channel-individual manner and differently from each other in order to correct channel-individual imaging errors; wherein the electronic image stabilizer is configured to execute the channel-individual electronic image stabilization in each channel according to a determined functional connection that describes the channel-individual imaging error as a function of a respective focal length of optics of the optical channel and of the relative movements between the image sensor, the array and the beam-deflecting means; or wherein the electronic image stabilizer is configured to identify, in a first partial image of a first partial field of view and in a second image of a second partial field of view, a matching feature, and to provide the electronic image stabilization based on a comparison of movements of the feature in the first and the second image.

In another embodiment, there is provided a method of providing a multi-aperture imaging device, comprising: providing an image sensor; providing an array of optical channels such that each optical channel includes an optic for projecting a partial field of view of a total field of view on an image sensor area of the image sensor; arranging a beam-deflecting means for deflecting an optical path of the optical channels; and arranging an optical image stabilizer for the image stabilization along a first image axis by generating a first relative movement between the image sensor, the array and the beam-deflecting means and for the image stabilization along a second image axis by generating a second relative movement between the image sensor, the array and the beam-deflecting means; arranging an electronic image stabilizer for the image stabilization of a first optical channel of the array along the first and the second image axis; such that at least one of the optical image stabilizer is configured to execute the optical image stabilization such that the optical image stabilization for an image of a first of the partial fields of view as reference image is as exact as possible, such that the electronic image stabilizer is configured to stabilize an image of a second partial field of view based on the reference image of the optical image stabilizer; the optical image stabilizer is configured to stabilize an image of the imaged partial field

of view of a reference channel of the optical channels, and such that the electronic image stabilizer is configured to execute, by means of channel-individual image evaluation of the movement of image details, an image stabilization in a channel-individual manner for optical channels that differ from the reference channel, such that the multi-aperture imaging device is configured to stabilize the reference channel exclusively in an optical manner; the optical image stabilizer is configured to stabilize an image of the imaged partial field of view of a reference channel of the optical channels, and such that the electronic image stabilizer is configured to execute an image stabilization in a channel-individual manner and differently from each other for optical channels that differ from the reference channel, such that the multi-aperture imaging device is configured to stabilize the reference channel exclusively in an optical manner; the electronic image stabilizer is configured to execute, by means of channel-individual image evaluation of the movement of image details, an image stabilization for each optical channel in a channel-individual manner in order to correct channel-individual imaging errors; the electronic image stabilizer is configured to execute an image stabilization for each optical channel in a channel-individual manner and differently from each other in order to correct channel-individual imaging errors; such that the electronic image stabilizer is configured to execute the channel-individual electronic image stabilization in each channel according to a determined functional connection that describes the channel-individual imaging error as a function of a respective focal length of optics of the optical channel and of the relative movements between the image sensor, the array and the beam-deflecting means; or such that the electronic image stabilizer is configured to identify, in a first partial image of a first partial field of view and in a second image of a second partial field of view, a matching feature, and to provide the electronic image stabilization based on a comparison of movements of the feature in the first and the second image.

Further embodiments relate to an imaging system and a method of providing a multi-aperture imaging device.

Preferred embodiments of the present invention are subsequently described with reference to the accompanying drawings, in which:

Fig. 1a shows a schematic view of a multi-aperture imaging device according to an embodiment;

Fig. 1b shows a schematic view of a multi-aperture imaging device according to an embodiment, wherein an actuator is connected to an image sensor;

5 Fig. 2a shows a schematic side-sectional view of a further multi-aperture imaging device according to an embodiment;

Fig. 2b shows a schematic side-sectional view of the multi-aperture imaging device of Fig. 2a;

- Fig. 3 shows a schematic top view of a multi-aperture imaging device, wherein a beam-deflecting means includes various beam-deflecting elements, according to an embodiment;
- 5
- Fig. 4a shows a schematic perspective view of a multi-aperture imaging device having optical channels that are arranged in a single-line manner, according to an embodiment;
- 10
- Fig. 4b shows a schematic illustration of a total field of view according to an embodiment, e.g., as may be captured with a multi-aperture imaging device described herein;
- Fig. 4c shows a schematic perspective illustration of the multi-aperture imaging device of Fig. 4a, which is used as a basis for describing an advantageous implementation of a combination of the optical image stabilization and the electronic image stabilization;
- 15
- Fig. 5a shows a schematic illustration of a beam-deflecting means that is formed as an array of facets according to an embodiment;
- 20
- Fig. 5b shows a schematic view of the beam-deflecting means according to an embodiment, wherein, as compared to the illustration in Fig. 5a, facets comprise a different sorting;
- 25
- Figs. 6a-f show advantageous implementations of a beam-deflecting means according to embodiments;
- Fig. 7 shows a schematic perspective illustration of an imaging system according to an embodiment;
- 30
- Fig. 8 shows a schematic perspective view of a portable device including two multi-aperture imaging devices, according to an embodiment;

Fig. 9 shows a schematic structure including a first multi-aperture imaging device and a second multi-aperture imaging device having a mutual image sensor, a mutual array and a mutual beam-deflecting unit;

5 Figs. 10a-e show schematic illustrations of an implementation of the electronic image stabilizer according to an embodiment; and

Fig. 11 shows a schematic illustration of a method according to an embodiment of providing a multi-aperture imaging device.

10
Before embodiments of the present invention will subsequently be explained in detail with reference to the drawings, it shall be pointed out that identical, functionally identical and operatively identical elements, objects and/or structures are provided in the different figures with identical reference numerals so that the description of these elements in different embodiments is interchangeable and/or mutually applicable.

Fig. 1a shows a schematic view of a multi-aperture imaging device 10 according to an embodiment. The multi-aperture imaging device 10 includes an image sensor 12, an array 14 of optical channels 16a-h, a beam-deflecting means 18 and an optical image stabilizer 22. Each
20 optical channel 16a-h includes an optic 64a-h for projecting a partial field of view of a total field of view on an image sensor area 24a-h of the image sensor 12. Optical channels may be understood as a progression of optical paths. The optical paths may be influenced by the optic 64a-h that is arranged in the array 14, e.g., by scattering or concentration. The individual optical channels may each form a complete imaging optic and may each comprise at least one optical
25 component, or optic, such as a refractive, diffractive or hybrid lens, and may image a section of the total object entirely captured with the multi-aperture imaging device. This means that one, several or all of the optics 64a-h may also be combinations of optical elements. An aperture diaphragm may be arranged with respect to one, several or all of the optical channels.

30 For example, the image sensor areas 24a-h may each be formed of a chip that includes a corresponding pixel array, wherein the image sensor areas may be mounted on a mutual substrate, or a mutual circuit carrier, such as a mutual circuit board or a mutual flex board. Alternatively, it would obviously also be possible that the image sensor areas 24a-h may each be formed of a part of a mutual pixel array that continuously extends across the image sensor

areas 24a-h, wherein the mutual pixel array is formed, e.g., on a single chip. For example, only the pixel values of the mutual pixel array are read out in the image sensor areas 24a-h. Various combinations of these alternatives are obviously also possible, e.g., the presence of a chip for two or more channels and a further chip for other channels or the like. In the case of several chips of the image sensor 12, e.g., these may be mounted on one or several circuit boards or circuit carriers, e.g., all together or in groups or the like. Furthermore, possible is also a solution that uses a single chip that comprises several individual pixel fields. Alternative embodiments comprise several chips that, in turn, comprise individual pixel fields.

10 The beam-deflecting means 18 is configured to deflect an optical path 26 of the optical channels 16a-h. The image stabilizer 22 is configured to enable an optical image stabilization along a first image axis 28 and along a second image axis 32 based on a relative movement between the image sensor 12, the array 14 and the deflecting means 18. The first image axis 28 and the second image axis 32 may be affected by an arrangement or orientation of the image sensor areas 24a-h and/or the image sensor 12. According to an embodiment, the image axes 28 and 32 are arranged perpendicular to each other and/or coincide with extension directions of pixels of the image sensor areas 24a-d. Alternatively or additionally, the image axes 28 and 32 may indicate an orientation along which a partial field of view or the total field of view is sampled or captured. Simply put, the image axes 28 and 32 may be a first and a second direction, respectively, in an image captured by the multi-aperture imaging device 10. For example, the image axes 28 and 32 comprise an angle of $\neq 0^\circ$ with respect to each other, e.g., the same are arranged perpendicular to each other in the space.

Optical image stabilization may be advantageous when, during a capturing process during which partial fields of view or the total field of view are captured, the multi-aperture imaging device 10 is moved with respect to the object area whose field of view is captured. The optical image stabilizer 22 may be configured to at least partially counteract this movement in order to reduce or to prevent shaking of the image. For the optical image stabilization along the image axis 28, the optical image stabilizer 22 may be configured to generate a first relative movement 34 between the image sensor 12, the array 14 and the beam-deflecting means 18. For the optical image stabilization along the image axis 32, the optical image stabilizer 22 is configured to generate a second relative movement between the image sensor 12, the array 14 and the beam-deflecting means 18. For the first relative movement 34, the optical image stabilizer 22 may include an actuator 36 and/or an actuator 37 for generating the relative movement 34 by

- 6 -

displacing the array 14 and/or the image sensor 12 along the image axis 28. In other words, although the actuator 36 is illustrated such that the same displaces or moves the array 14 in a translational manner, the actuator 36, according to further embodiments, may alternatively or additionally be connected to the image sensor 12 and may be configured to move the image sensor 12 relative to the array 14. Alternatively or additionally, the optical image stabilizer may include an actuator 42 that is configured to generate a translational movement 39a of the beam-deflecting means 18 along the image axis 28. In this case, the optical image stabilizer 22 is configured such that the same executes the movements of the actuators 36, 37 and/or 42 so that the relative movement 34 is created between the image sensor 12, the array 14 and the beam-deflecting means 18. This means that, although in Fig. 1a the relative movement 34 is illustrated at the array 14, alternatively or additionally, other components may be moved. The relative movement 34 may be executed in parallel to a line extension direction 35 and perpendicularly to the optical paths 26. However, it may be advantageous to set the array 14 in motion with respect to the image sensor 12 in a translational manner in order to, e.g., mechanically stress an electric interconnection of the image sensor 12 with respect to further components as little as possible or not at all.

For generating the second relative movement, the optical image stabilizer 22 may be configured to generate or enable a rotational movement 38 of the beam-deflecting means 18 and/or to provide a translational relative movement between the image sensor 12 and the array 14 along the image axis 32 and/or a translational relative movement between the array 14 and the beam-deflecting means 18, wherein the actuators 36, 37 and/or 42 may be arranged for this purpose. For generating the rotational movement 38, the optical image stabilizer 22 may, e.g., include the actuator 42 that is configured to generate the rotational movement 38. Alternatively, the optical image stabilizer 22 may be configured to generate a translational movement 39b along the image axis 32 using the actuator 42. Based on the first relative movement 34 and/or 39a, an optical image stabilization may be obtained along an image direction parallel thereto, e.g., along or opposite to the image axis 28. Based on the second relative movement 38 and/or 39b, an optical image stabilization may be obtained along an image direction that is arranged perpendicular to a rotation axis 44 of the rotational movement 38 in a main side plane of the image sensor 12, e.g., along the image axis 32. A main side may be understood to be a side that comprises a large or the largest dimension compared to other sides. Alternatively or additionally, a focusing means such as described in connection with Fig. 3 may be arranged, which is configured to change a focus of the multi-aperture imaging device. Although

- 7 -

implementing the optical stabilizer 22 such that the same controls the first and the second relative movement as translational relative movements is possible for obtaining the optical image stabilization, implementing the second relative movement as a rotational movement 38 may be advantageous since, in this case, a translational movement of components along the second image axis 32 may be avoided. This direction may be parallel to a thickness direction of the multi-aperture imaging device 10, which, according to several embodiments, is to be kept as small as possible. Such an object may be achieved by the rotational movement.

Simply put, instead of a translational movement perpendicular to the relative movement 34, the rotational movement 38 may be used in order to obtain the optical image stabilization along the second image axis 32. This makes it possible to save installation space for enabling the translational relative movement perpendicular to the relative movement 34. For example, the translational relative movement may be arranged perpendicular to a thickness direction of the device so that the device may be implemented with a small thickness, i.e., in a thin manner. This offers particular advantages in the field of mobile devices, as these may be implemented with a flat housing.

The multi-aperture imaging device 10 comprises an electronic image stabilizer 41 that is configured to electronically stabilize the partial images that are projected on the image sensor areas 24a-h, that is, by manipulating the image data. For this purpose, different methods may be used individually or in combination, e.g., electronic vibration reducing (e-VR), Coolpix S4, Anti-Shake-DSP and/or Advanced Shake Reduction (ASR). The electronic image stabilizer 41 is configured to stabilize a first partial image of the image sensor areas 24a-h of a first optical channel 16a-h of the array 14 to a first extent. Furthermore, the electronic image stabilizer 41 may be configured to additionally stabilize a second partial image of the image sensor areas 24a-h of a second optical channel 16a-h of the array 14 to a second extent that differs from the first extent, i.e., in a channel-individual manner. In this case, the extent relates to an image correction that is executed along the first and the second image axis 28 and 32, wherein rotations around image axes and the like are also included in this case.

In implementations, the electronic image stabilizer 41 is configured to execute the electronic image stabilization in a channel-individual manner for each optical channel, i.e., for each of the partial images of the image sensor areas 24a-h. With this, different aberrations or even channel-individual aberrations may be corrected for the first and the second optical channel 16a-h.

The optics 64a-h of the optical channels may each comprise different optical characteristics. For example, a different optical characteristic is obtained by manufacturing tolerances so that the optics 64a-h differ from each other in a tolerance range of at most $\pm 10\%$, at most $\pm 5\%$ or at most $\pm 3\%$ with respect to one or several optical characteristics such as focal length, field of view angle, optical diameter or the like.

It was recognized that, in the context of optical characteristics of the optics 64a-h that differ in a manufacturing-related manner, an optical image stabilization by a relative movement between the image sensor 12, the optic 64a-h of the respective optical channel and the beam-deflecting means 18 lead to the fact that the images in the image sensor areas 24a-d change in a different manner. This is at least partly due to the fact that the mechanical movement for achieving an optical image stabilization that is executed in the same manner for all optical channels, i.e., in a channel-global manner, leads to a different change of the optical path through the optics 64a-h. Now, the different optical characteristics affect the images of the image sensor areas 24a-h differently or even channel-individually. In other words, different image displacements per channel at relative movements between the beam-deflecting unit and/or the array and/or the image sensor affecting all channels in the same manner result in particular from the different focal lengths of the channels. This may be reduced, i.e., at least partially balanced out or compensated, by the electronic image stabilization that is combined with the optical image stabilization. This is to be highlighted based on the optical characteristic of focal length. With two different values of the optical focal length in optics that are directed to the same total field of view, the relative movement in the context of the optical image stabilization leads to the fact that the view axis and/or view direction of the optical channels are equally changed. Due to the different focal lengths in the optics 64a-h, however, the partial images in the image sensor areas 24a-h move differently, which may lead to a high computational effort or even to aberrations when joining the partial images, i.e. when performing the stitching.

For example, the array 14 may comprise a carrier 47 through which the optical channels 16a-h extend. For this, for example, the carrier 47 may be configured to be opaque and may comprise transparent areas for the optical channels 16a-h. Inside of or adjacent to the transparent areas and/or at end areas of the same, the optics 64a-h of the optical channels 16a-h may be arranged. Alternatively or additionally, the carrier 47 may be formed to be a transparent, and may, e.g., comprise a polymer material and/or a glass material. The optics (lenses) 64a-h that

influence the projection of the respective partial field of view of the total field of view on the respective image sensor area 24a-h of the image sensor may be arranged at a surface of the carrier 47.

- 5 For example, the actuators 36 and/or 42 may be formed as a pneumatic actuator, a hydraulic actuator, a piezoelectric actuator, a direct-current motor, a stepper motor, a thermally-actuated actuator, an electrostatic actuator, an electrostrictive actuator, a magnetostrictive actuator or a moving coil drive.
- 10 For example, the beam-deflecting means 18 may be formed to be reflecting at least in areas. For example, the beam-deflecting means 18 may include areas or beam-deflecting elements 46a-d that are configured to deflect the optical paths 26 such that the deflected optical paths comprise different angles and capture different partial fields of view of a total field of view. The different angles may be created by the beam-deflecting means 18 and/or the optics 64a-h of the
- 15 optical channels 16a-h. For example, the areas 46a-d may be formed as facets of a facet mirror. The facets may comprise different inclinations with respect to the array 14. This may enable a deflection, influence, drive and/or scattering of the optical paths 26 towards differently arranged partial fields of view. Alternatively, the beam-deflecting means 18 may be configured as a surface that is configured to be reflecting on one side or on two sides, e.g., as a mirror. This
- 20 surface may be formed to be plane, or continuously curved in portions or plane, and/or discontinuously curved in portions or plane. A deflection of the optical paths 26 may alternatively or additionally be obtained by means of the optics 64a-h of the optical channels 16a-h.

In other words, a relative movement for the optical image stabilization causes the same

25 mechanical deflection in all channels of the multi-aperture camera. However, the obtained image displacement that defines the actual mechanism of action of the optical image stabilization additionally depends on the focal length of the imaging optic of each channel. Thus, it is one recognition that, additionally to the optical image stabilization that is globally executed for all channels in the same manner, a channel-individual electronic image stabilization is

30 introduced. The beam-deflecting means may be used both for deflecting the view direction and also for the optical image stabilization.

The beam-deflecting means may be plane across the area of all channels, may comprise a continuous or discontinuous profile and/or may partially be plane, i.e., faceted, wherein the

- 10 -

transitions between individual continuous or discontinuous profiles may additionally comprise local maskings for reducing the reflectivity or may comprise mechanical structures in order to reduce aberrations and/or to enable a stiffening of the structure so that aberrations that are induced by movement and/or that are thermally induced may be at a minimum.

5

Switching between the first position and the second position of the beam-deflecting means may occur along the rotation axis 44 in a translational manner. A movement along the rotation axis 44 may be executed in a continuous or discontinuous manner, e.g., in a bi-stable or multi-stable manner. For example, this may be understood as position-discrete positions between which the beam-deflecting means 18 is moved. For example, single-stable, bi-stable or multi-stable positions may be obtained by implementing the actuator 42 or another actuator as a stepper motor. For example, if the beam-deflecting means 18 is configured to be moved back and forth between two positions, e.g., one of the positions may be an idle position of the actuator or may be based thereon. For example, the actuator may be configured to execute the translational movement with respect to a spring force that applies a counterforce when reaching the respective other position, which moves the beam-deflecting means back to its starting position upon removing the force of the actuator. This means that a stable position may also be obtained in areas of a force diagram which do not comprise a local force minimum. For example, this may be a force maximum. Alternatively or additionally, a stable position may be obtained based on magnetic or mechanical forces between the beam-deflecting means 18 and a neighboring housing or substrate. This means that the actuator 42 or the other actuator may be configured for moving the beam-deflecting means in a translational manner in order to move the beam-deflecting means into a bi-stable or multi-stable position. Alternatively, simple mechanical stops may be provided for bi-stable arrangements of the positions, which define two end positions between which a position switch takes place in the defined end positions.

Fig. 1b shows a schematic view of a multi-aperture imaging device 10' according to an embodiment. With respect to the multi-aperture imaging device 10, the multi-aperture imaging device 10' is modified in that the actuator 36 is mechanically connected to the image sensor 12 and configured to move the image sensor 12 relative to the array 14. The relative movement 34 may be executed in parallel to the line extension direction 35 and perpendicularly to the optical paths 26.

30

- 11 -

Fig. 2 a shows a schematic side-sectional view of a multi-aperture imaging device 20 according to an embodiment. For example, the multi-aperture imaging device 20 may modify the multi-aperture imaging device 10 in that the actuators 36 and/or 42 are arranged such that the same are arranged at least partially between two planes 52a and 52b that are spanned by sides 53a and 53b of a cuboid 55. The sides 53a and 53b of the cuboid 55 may be oriented in parallel to each other and in parallel to the line extension direction of the array and of a part of the optical path of the optical channels between the image sensor and the beam-deflecting means. The volume of the cuboid 55 is at a minimum and still includes the image sensor 12, the array 14 and the beam-deflecting means 18 as well as their operational movements. Optical channels of the array 14 comprise an optic 64 that may be formed to be the same for each optical channel or that may be different.

A volume of the multi-aperture imaging device may comprise a low or minimal installation space between the planes 52a and 52b. An installation space of the multi-aperture imaging device may be large or arbitrarily large along the lateral sides or the extension directions of the planes 52a and/or 52b. For example, the volume of the virtual cuboid is affected by an arrangement of the image sensor 12, the single-line array 14 and the beam-deflecting means, wherein the arrangement of these components according to the embodiments described herein may be carried out such that the installation space of these components along the direction perpendicular to the planes and therefore also the distance between the planes 52a and 52b with respect to each other become low or a minimum. Implementing the multi-aperture imaging device as thinly as possible is desired particularly in the area of mobile applications, e.g., for mobile telephones or tablets. With respect to other arrangements of the components, the volume and/or the distance of other sides of the virtual cuboid may be increased.

The virtual cuboid 55 is illustrated by dotted lines. The planes 52a and 52b may include two sides of the virtual cuboid 55 or may be spanned thereby. A thickness direction 57 of the multi-aperture imaging device 20 may be arranged to be normal to the planes 52a and/or 52b and/or parallel to the y direction.

The image sensor 12, the array 14 and the beam-deflecting means 18 may be arranged such that a perpendicular distance between the planes 52a and 52b along the thickness direction 57 is at a minimum, which may be referred to as a height of the cuboid for reasons of simplification but without having a limiting effect, wherein a miniaturization of the volume, i.e., the other

- 12 -

dimensions of the cuboid, may be omitted. An expansion of the cuboid 55 along the direction 57 may be a minimum and may essentially be predefined by the expansion of the optical components of the imaging channels, i.e., the array 14, the image sensor 12 and the beam-deflecting means 18, along the direction 57.

5

A volume of the multi-aperture imaging device may comprise a low or minimal installation space between the planes 52a and 52b. An installation space of the multi-aperture imaging device may be large or arbitrarily large along the lateral sides or the extension directions of the planes 52a and/or 52b. For example, the volume of the virtual cuboid is affected by an arrangement of
10 the image sensor 12, the single-line array 14 and the beam-deflecting means, wherein the arrangement of these components according to the embodiments described herein may be carried out such that the installation space of these components along the direction perpendicular to the planes and therefore also the distance between the planes 52a and 52b with respect to each other become low or a minimum. With respect to other arrangements of the
15 components, the volume and/or the distance of other sides of the virtual cuboid may be increased.

The actuators, e.g., the actuator 36 and/or 42, of the multi-aperture imaging device may comprise a dimension or expansion in parallel to the direction 57. A percentage of not more
20 than 50%, not more than 30% or not more than 10% of the dimension of the actuator or the actuators may, starting from an area between the planes 52a and 52b, extend beyond the plane 52a and/or 52b or extend out of the area. This means, that the actuators extend beyond the plane 52a and/or 52b not more than in an insignificant manner. According to embodiments, the actuators do not extend beyond the planes 52a and 52b. In this case, it is advantageous that an
25 expansion of the multi-aperture imaging device 10 along the thickness direction, or direction 57, is not increased by the actuators.

The image stabilizer 22 and/or the actuators 36 and/or 42 may comprise a dimension or expansion in parallel to the thickness direction 57. A percentage of not more than 50%, not
30 more than 30% or not more than 10% of the dimension may, starting from an area between the planes 52a and 52b, extend beyond the plane 52a and/or 52b or extend out of the area, e.g., as is illustrated for the actuator 42', which indicates an offset arrangement of the actuator 42. This means that the actuators 36 and/or 42 extend beyond the plane 52a and/or 52b not more than in an insignificant manner. According to embodiments, the actuators 36 and/or 42 do not extend

- 13 -

beyond the planes 52a and 52b. In this case, it is advantageous that an expansion of the multi-aperture imaging device 20 along the thickness direction 57 is not increased by the actuators 36 and/or 42.

5 Although terms such as up, down, left, right, front or back are used herein for reasons of a better clarity, these are not intended to have any limiting effect. It is understood that these terms are mutually exchangeable based on a rotation or tilt in the space. For example, starting from the image sensor 12 towards the beam-deflecting means 18, the x direction may be understood to be the front or to be forward. For example, a positive y direction may be understood to be up.
10 An area along the positive or negative z direction away from or spaced apart from the image sensor 12, the array 14 and/or the beam-deflecting means 18 may be understood to be next to the respective component. Simply put, the image stabilizer may at least include one actuator 36 and/or 42. The at least one actuator 36 and/or 42 may be arranged in the plane 48 or between the planes 52a and 52b, respectively.

15
In other words, the actuators 36 and/or 42 may be arranged in front of, behind or next to the image sensor 12, the array 14 and/or the beam-deflecting means 18. According to embodiments, the actuators 36 and 42 are arranged outside of the area between the planes 52a and 52b with a maximum extent of 50%, 30% or 10%. This means that the at least one actuator
20 36 and/or the image stabilizer 22 along the thickness direction 57 perpendicular to the plane 48 extends out of the plane, or the area between the maximum dimensions 52a-52b, by not more than 50% of the dimension of the actuator 36 and/or 42 of the image stabilizer along the thickness direction 57. This enables a small dimension of the multi-aperture imaging device 20 along the thickness direction 57.

25
Fig. 2b shows a schematic side-sectional view of the multi-aperture imaging device 20, wherein the optical paths 26 and 26' indicate different view directions of the multi-aperture imaging device 20. The multi-aperture imaging device may be configured to change a tilt of the beam-deflecting means by an angle α so that different main sides of the beam-deflecting means 18
30 are arranged facing the array 14 in an alternating manner. The multi-aperture imaging device 20 may include an actuator that is configured to tilt the beam-deflecting means 18 around the rotation axis 44. For example, the actuator may be configured to move the beam-deflecting means 18 into a first position in which the beam-deflecting means 18 deflects the optical path 26 of the optical channels of the array 14 into the positive y direction. For this, in the first position,

- 14 -

the beam-deflecting means 18 may, e.g., comprise an angle α of $> 0^\circ$ and $< 90^\circ$, of at least 10° and not more than 80° or of at least 30° and not more than 50° , e.g., 45° . The actuator may be configured to deflect the beam-deflecting means in a second position in such a way around the rotation axis 44 that the beam-deflecting means 18 deflects the optical path of the optical channels of the array 14 towards the negative y direction, as is illustrated by the optical path 26' and the dotted illustration of the beam-deflecting means 18. For example, the beam-deflecting means 18 may be configured to be reflecting on both sides so that, in the first position, a first optical path 26 or 26', respectively, is deflected or reflected. According to an advantageous implementation, the multi-aperture imaging device 20 is configured to execute a switch between the first position and the second position such that, between the two positions, an auxiliary side is associated to the array 14 but such that an orientation according to which a main side entirely faces the array 14 is avoided. This may also be understood such that, during a switch between the first and the second operation states or positions by the rotational movement, a surface normal 51a of the first main side and a second surface normal 51b of the second main side comprise at each point in time an angle γ_1 and γ_2 of at least 10° with respect to a direction towards the image sensor and, if applicable, parallel to a surface normal of the image sensor 12. In this way, it may be avoided that one of the angles γ_1 and γ_2 is 0° or 180° , which could indicate a large or approximately maximum expansion of the beam-deflecting means 18 along the thickness direction.

Fig. 3 shows a schematic top view of a multi-aperture imaging device 30 according to an embodiment. Compared to the multi-aperture imaging device 10 and/or 20, the multi-aperture imaging device 30 may be modified such that the multi-aperture imaging device 30 includes a focusing means 54 that is configured to change a focus of the multi-aperture imaging device 30. This may be carried out based on a variable distance 56 between the image sensor 12 and the array 14, as is illustrated by the distance 56'.

The focusing means 54 may include an actuator 58 that is configured, upon an actuation, to be deformed and/or to provide a relative movement between the image sensor 12 and the array 14. This is exemplarily illustrated for the multi-aperture imaging device 30 such that the actuator 58 is configured to displace the array 14 along the positive and/or the negative x direction with respect to the image sensor 12. For example, the array 14 may be supported at one side such that, based upon an actuation of the actuator 58, it is moved along a positive or negative x direction and essentially remains unmoved along a positive and/or negative z direction. An

- 15 -

additional movement along the positive and/or negative z direction for an optical image stabilization may be obtained, e.g., based on an actuation of the actuator 36. According to further embodiments, the actuator 58 and/or the focusing means 54 is configured to obtain the relative movement between the image sensor 12 and the array 14 along the x axis based on a translational displacement of the image sensor 12 with respect to the array 14. According to further embodiments, the image sensor 12 and the array 14 may be moved. According to further embodiments, the focusing means 54 may comprise at least one further actuator. For example, a first actuator and a second actuator may be arranged at two opposing areas of the array 14 so that, upon an actuation of the actuators, a requirement for a support of the moveable array 14 (alternatively or additionally to the image sensor 12) is reduced. Additionally, the actuator 58 or a further actuator may be configured to keep a distance between the single-line array 14 and the beam-deflecting means 18 essentially or, even when not using an additional actuator, exactly constant, i.e., to move the beam-deflecting means 18 to such an extent as the signal-line array 14. The focusing means 54 may be configured to enable an autofocus function by a relative translational movement (focusing movement) between the image sensor 12 and the array 14 along a surface normal of the image sensor 12. In this case, the beam-deflecting means 18 may be moved simultaneously to the focusing movement by a corresponding constructive implementation or a usage of the actuator 42 or of a further actuator. This means that a distance between the array 14 and the beam-deflecting means remains unchanged and/or that the beam-deflecting means 18 is moved in a simultaneous or time-offset manner to a same or comparable extent as the focusing movement so that, at least at a point in time of capturing the field of view by the multi-aperture imaging device, the distance is unchanged compared to a distance before changing the focus. This may be carried out such that the beam-deflecting means 18 is moved together with the actuator 42, i.e., simultaneously, so that a distance between the array 14 and the beam-deflecting means remains constant or is compensated. This means that a distance between the array 14 and the beam-deflecting means 18 may remain unchanged and/or that the beam-deflecting means 18 may be moved in a simultaneous or time-offset manner to a same or comparable extent as the focusing movement so that, at least at a point in time of capturing the field of view by the multi-aperture imaging device, the distance between the array 14 and the beam-deflecting means 18 is unchanged compared to a distance before changing the focus. Alternatively, the beam-deflecting means 18 may be idle or may be excluded from the autofocus movement.

- 16 -

For example, the actuator 58 may be implemented as a piezoelectric actuator such as a bending bar (e.g., a bimorph, a trimorph or the like). Alternatively or additionally, the focusing means 54 may include a moving coil drive, a pneumatic actuator, a hydraulic actuator, a direct current motor, a stepper motor, an actuator or a bending bar that may be thermally actuated, an electrostatic actuator, an electrostrictive and/or an magnetostrictive drive.

As described in connection with the image stabilizer and an arrangement of the same in the plane 48 and/or in an area between the plane 52a and 52b, the at least one actuator 58 of the focusing means 54 may at least partially be arranged between the planes 52a and 52b. Alternatively or additionally, the at least one actuator 58 may be arranged in a plane in which the image sensor 12, the array 14 and the beam-deflecting means 18 are arranged. For example, the actuator 58 of the focusing means 54 along the thickness direction 57 perpendicular to the plane 48, in which the image sensor 12, the array 14 and the beam-deflecting means 18 are arranged, may extend out of the area between the planes 52a and 52b by not more than 50% of the dimension of the actuator 58 of the focusing means 54 along the thickness direction 57. According to embodiments, the actuator extends out of the area between the planes 52a and 52b by not more than 30%. According to another embodiment, the actuator 54 extends out of the area by not more than 10% or is located entirely inside of the area. This means that, along the thickness direction 57, no additional installation space needs are required for the focusing means 54, which is advantageous. For example, if the array 14 comprises a transparent substrate (carrier) 62 having lenses 64a-d arranged thereat, a dimension of the array 14 and, if applicable, of the multi-aperture imaging device 30 along the thickness direction 57 may be small or a minimum. With reference to Fig. 2a, this may indicate that the cuboid 55 comprises a small thickness along the direction 57 or that the thickness is unaffected by the substrate 62. The substrate 62 may be passed by the optical paths that are used for imaging in the individual optical channels. The optical channels of the multi-aperture imaging device may traverse the substrate 62 between the beam-deflecting means 18 and an image sensor 12.

For example, the lenses 64a-d may be liquid lenses, i.e., an actuator may be configured to drive the lenses 64a-d. Liquid lenses may be configured to adjust and to vary individually per channel the refractive power and, therefore, the local length and the image position.

Fig 4a shows a schematic perspective view of a multi-aperture imaging device 40 according to an embodiment. For example, compared to the multi-aperture imaging device 10, the array 14 is

- 17 -

configured in a single-line manner, which means that all optical channels 16a-d may be arranged along a line extension direction of the array 14 in a single line. The term single-line may also indicate an absence of further lines. A single-line implementation of the array 14 enables a small dimension of the array and, possibly, of the multi-aperture imaging device 40 along the thickness direction 57. The optical image stabilizer includes actuators 36a and 36b that together form the actuator 36, which means that an actuator described herein may also be implemented by several actuators or control elements, and/or several actuators may be combined to a mutual actuator.

10 The multi-aperture imaging device 40 may be configured to, based on the beam-deflecting means 18, capture fields of view in different directions. For example, the beam-deflecting means may comprise a first position Pos1 and a second position Pos2. Based on a translational or rotational movement, the beam-deflecting means may be switchable between the first position Pos1 and the second position Pos2. For example, the beam-deflecting means 18 may be
15 moved along the line extension direction z of the single-line array 14 in a translational manner, e.g., as is indicated by a translational movement 66. For example, the translational movement 66 may essentially be arranged in parallel to a line extension direction 65 along which the at least one line of the array 14 is arranged. For example, the translational movement may be used in order to place different facets in front of the optics of the optical channels 16a-d in order
20 to obtain different view directions of the multi-aperture imaging device 40. The beam-deflecting means 18 may be configured to deflect, in the first position Pos1, the optical paths 26a-d in a first direction, e.g., at least partially in a positive y direction. The beam-deflecting means 18 may be configured to direct, in the second position Pos2, the optical paths 26a-d, i.e., of each optical channel 16a-d, in a different direction, e.g., at least partially along the negative y direction. For
25 example, the actuator 42 may be configured to move, based on a movement of the beam-deflecting means 18 along the movement direction 66, the beam-deflecting means 18 from the first position Pos1 to the second position Pos2. The actuator 42 may be configured to overlap the translational movement along the movement direction 66 with the rotational movement 38. Alternatively, the multi-aperture imaging device 40 may also include a further actuator that is
30 configured to move the beam-deflecting means along the movement direction 66 or opposite thereto.

As is described in connection with Fig. 2b, the actuator 42 may be configured to obtain the first and/or the second position of the beam-deflecting means 18 based on a rotation of the same.

- 18 -

The movement between the first position Pos1 and the second position Pos2 may be overlapped with the rotational movement 38 both for a rotational movement for switching between the positions and also for the translational movement along the direction 66.

5 Fig. 4b shows a schematic illustration of a total field of view 70, e.g., as may be captured with a multi-aperture imaging device as previously described, e.g., the multi-aperture imaging device 10, 20, 30 or 40, wherein, e.g., the multi-aperture imaging device 10 may subdivide the total field of view 70 into a larger or smaller number of partial fields of view 72a-d. The optical paths of the optical channels of the multi-aperture imaging devices may be directed to different partial
10 fields of view 72a-d, wherein a partial field of view 72a-d may be associated to each optical channel. For example, the partial fields of view 72a-d overlap with each other in order to enable joining individual partial images into a total image. If the multi-aperture imaging device comprises a number of optical channels that is different from four, the total field of view 70 may comprise a number of partial fields of view that is different from four. Alternatively or additionally,
15 at least one partial field of view 72a-d may be captured by a second or a larger number of optical channels of a larger number of modules (multi-aperture imaging devices) in order to implement stereo cameras, trio cameras, quartet cameras in order to be able to capture three-dimensional object data therewith. The modules may be implemented individually or as a linked system and may be arranged at any location in a housing of the multi-aperture imaging device.
20 The images of the different modules that together form the stereo cameras, trio cameras, quartet cameras may be displaced by fractions of a pixel and may be configured to implement methods of the super resolution. A number of optical channels and/or a number of multi-aperture imaging devices and/or a number of partial fields of view is, e.g., arbitrary and may comprise a number of at least two, at least three, at least four, at least ten, at least 20 or any
25 higher value. The optical channels of the further line may also capture respective overlapping partial areas and may together cover the total field of view. This enables obtaining a stereo structure, trio structure, quartet structure, etc. of array cameras that consist of channels that partially overlap and that cover the total field of view in their partial grouping.

30 Fig. 4c is a schematic perspective illustration of the multi-aperture imaging device 40, based on which an advantageous implementation of a combination of the optical image stabilization and the electronic image stabilization is explained. The optical image stabilizer 22 includes actuators 36a, 36b and 42, wherein the actuators 36a and 36b are configured to obtain the optical image stabilization of the images of the partial fields of view in the image sensor areas 24a to 24d by

- 19 -

displacing the array 14 along the line extension direction 65. Furthermore, e.g., the optical image stabilizer is configured to obtain an optical image stabilization along the image axis 32 by the rotational movement 38. For example, the optics 64a-d of the array 14 comprise a focal length f_1 to f_4 that are different from each other in a tolerance range of not more than 10%, not more than 5% or not more than 3%. The channel-global rotational movement 38 together with the different focal lengths f_1 to f_4 leads to a different displacement 69_1 to 69_4 of the images in the image sensor areas 24a-d. This means that the optical image stabilizer 22 achieves different effects in the images due to the channel-global rotational movement 38 so that at least one, several or all images deviate from a theoretical aberration-free state. The optical image stabilizer 22 may be configured to globally minimize the deviations of all images, however, which may lead to the fact that aberrations are created in each of the images. Alternatively, the optical image stabilizer 22 may be configured to select a reference image in one of the image sensor areas 22 and to execute the control of the actuator 42 such that the image in the reference image or in the reference channel is as accurate as possible, which may also be referred to as aberration-free. This means that, due to the channel-global optical image stabilization, a channel may be kept aberration-free with respect to the affected image direction, while the other channels deviate from this reference image due to the different focal lengths f_1 to f_4 . In other words, a channel is corrected with the mechanically realized optical image stabilizer which has the same effect for all channels, however, which does not keep all channels stable. These further channels are additionally corrected with the electronic image stabilizer.

The electronic image stabilizer 41 may be configured to execute a channel-individual electronic image stabilization in each channel according to a determined functional connection that depends on the relative movements between the image sensor 12, the array 14 and the beam-deflecting means 18. The electronic image stabilizer 41 may be configured to stabilize each image individually. For this, the electronic image stabilizer 41 may use global values, e.g., the camera movement or the like, in order to increase the optical quality of the images. It is particularly advantageous if the electronic image stabilizer 41 is configured to execute an electronic image correction starting from a reference image of the optical image stabilizer 22. The different focal lengths may provide the functional connection between the different changes in the images by the optical image stabilization preferably in a linear form, e.g., in the form of:

$$\text{aberration} = f(f_i, \text{relative movement}),$$

- 20 -

which means that the aberration may be illustrated globally or with respect to the reference channel as a function of the focal length or of focal length differences and the executed relative movement for changing the view direction or for the optical image stabilization. The electronic image stabilizer 41 may link an extent or a relative movement between the image sensor 12, the array 14 and the beam-deflecting means 18 with the focal lengths f_1 to f_4 or focal length differences with respect to the reference channel in order to obtain reliable information about the electronic image stabilization to be executed, and in order to create the functional connection and/or to use the same. The necessary data of the optical characteristics and/or of the functional connection may be obtained during a calibration. The alignment of images with respect to each other for determining a displacement of one image with respect to another image may also be carried by determining a matching feature in the images of the partial fields of view, e.g., edge progressions, objects sizes or the like. For example, this may be identified by the electronic image sensor 41 that may further be configured to provide the electronic image stabilization based on a comparison of movements of the features in the first and the second image. Thus, the channel-individual electronic image stabilization may be carried out by a channel-individual image evaluation of the movement of image details.

Alternatively or additionally to a comparison in different images, a comparison of the feature may also be carried out in the same image, in particular with respect to two captured images or frames that are temporally spaced apart. The optical image stabilizer 41 may be configured to identify a matching feature in the corresponding partial image at a first point in time and at a second point in time, and to provide the electronic image stabilization based on a comparison of movements of the feature in the first image. For example, the comparison may indicate a displacement by which the feature has been displaced by the relative movement and by which the image is to be displaced back in order to at least partially correct the aberration.

The optical image stabilizer may be used in order to stabilize an image of the imaged partial field of view of a reference channel such as the image in the image sensor area 24a. For example, the electronic image stabilizer 41 is configured to execute an image stabilization for optical channels different from the reference channel, which project on the image sensor areas 24b, 24c and 24d in a channel-individual manner. The multi-aperture imaging device may be configured to stabilize the reference channel exclusively in an optical manner. This means that in an implementation, a sufficiently good image stabilization may be achieved in a reference channel by solely using the mechanically achieved optical image stabilization. For the other

- 21 -

channels, an electronic image stabilization is additionally carried out in order to partially or entirely compensate the above-described effect of an insufficient optical image stabilization due to focal length differences, wherein the electronic stabilization is carried out individually in each channel.

5

According to a further embodiment, it is further possible that each channel of the multi-aperture imaging device comprises an individual electronic image stabilization. The electronic image stabilization individually carried out for each channel of the multi-aperture imaging device may be carried out such that a determined functional connection between the image displacements
10 to be realized in the individual channels is used. For example, the displacement along the direction 32 in a channel is 1.1 times, 1.007 times, 1.3 times or 2 times or 5 times the displacement along the direction 32 in another image. Furthermore, this channel-individual functional connection may depend on the relative movements between the beam-deflecting unit and/or the array and/or the image sensor, wherein the same may be linear or may correspond
15 to an angular function that projects a rotation angle of the beam-deflecting means on an extent of the electronic image stabilization along the image direction. An identical connection may be achieved for the direction 28 with the same or with different values.

For all embodiments, it is true that the realized relative movements may be captured by
20 corresponding additional sensors such as gyroscopes and the like, or may be derived from the captured image data of one, several or all channels. This data or information may be used for the optical and/or electronic image stabilization, which means that, e.g., the multi-aperture imaging device is configured to receive a sensor signal from a sensor, and to evaluate the sensor signal with respect to an information that is correlated with a relative movement between
25 the multi-aperture imaging device and the object, and to execute a control of the optical and/or electronic image stabilizer using this information.

The optical image stabilizer may be configured to obtain the optical image stabilization along the image axes 28 and 32 by moving various components, e.g., the array 14, for the stabilization
30 along the direction 28 and the rotation 38 of the beam-deflecting means for the stabilization along the direction 32. In both cases, differences in the optics 64a-d have an effect. The previous discussions with respect to the electronic image stabilization may be implemented for both relative movements. In particular, viewing the directions 28 and 32 separately enables a consideration of various deviations between the optics 64a-d along the directions 28 and 32.

Embodiments described herein may use a mutual image axis 28 and/or 32 for the partial images in the image sensor areas 24a-d. Alternatively, the directions may differ and may be converted into each other.

5

Fig. 5a shows a schematic illustration of a beam-deflecting means 18 that is formed as an array of facets 46a-h. For example, if the beam-deflecting means 18 is positioned in the first position, the facets 46a-d indicated with numbers 1, 2, 3 and 4, respectively, may deflect optical paths of four optical channels in a first direction. If the beam-deflecting means 18 comprises the second position, the optical path of each optical channel may be deflected in the second direction based on the facets 46e-h, as is indicated by numbers 1', 2', 3' and 4', respectively. For example, the facets 46a-d and 46e-h may be referred to as being arranged in blocks. A distance 88 that essentially corresponds to an extension length of the number of the optical channels along the line extension direction 65 may be covered for the translational movement of the beam-deflecting means 18 along the translational direction 66. According to the embodiment of Fig. 4a, e.g., this is an expansion of four optical channels along the line extension direction 65. According to a further embodiment, the number of beam-deflecting elements may differ from a multiple of the optical channels. At least one beam-deflecting element may be configured or arranged in a position of the beam-deflecting means in order to deflect optical paths of at least two optical channels.

10
15
20

Fig. 5b shows a schematic view of the beam-deflecting means 18, wherein the facets 46a-g comprise a different order in comparison to the illustration in Fig. 5a. The beam-deflecting means illustrated in Fig. 5b comprises an alternating arrangement of the optical channels 46a-g for each optical channel, as is indicated by the order 1, 1', 2, 2', 3, 3', 4 and 4'. This enables a distance 88' along which the beam-deflecting means 18 is moved in order to be switched between the first position and the second position. Compared to the distance 88 of Fig. 5a, the distance 88' may be small. For example, the distance 88' may essentially correspond to the distance in between two neighboring optical channels of the array 14. For example, two optical channels may comprise a distance or a gap with respect to each other that essentially at least corresponds to a dimension of a facet along the movement direction 65. The distance 88' may also be different from this, e.g., if a beam-deflecting element is configured or arranged in a position of the beam-deflecting means in order to deflect optical paths of at least two optical channels.

25
30

Advantageous implementations of the beam-deflecting means 18 are described based on Fig. 6a-f. The implementations show a number of advantages that may be executed individually or in any combinations, however, these are not intended to have a limiting effect.

5

Fig. 6a shows a schematic side-sectional view of a beam-deflecting element 172 that may be used as one of the beam-deflecting areas 46 in beam-deflecting means described herein. The beam-deflecting element 172 may be operable for one, a plurality or all of the optical channels 16a-d and may comprise a polygonal chain-like cross-section. Although a triangular cross-section is shown, it may be any other polygon. Alternatively or additionally, the cross-section may also comprise at least one curved surface, wherein a plane configuration at least in portions may be advantageous, in particular in reflecting surfaces, in order to avoid aberrations. The two main sides 174a and 174b may be inclined towards each other by an angle δ . The angle δ may comprise a value between 1° and 89° , preferably comprises a value between 5° and 60° , and particularly preferably comprises a value between 10° and 30° . Thus, the main sides 174a and 174b are preferably arranged to be inclined with respect to each other at an angle of not more than 60° .

For example, the beam-deflecting element 172 comprises a first side 174a, a second side 174b and a third side 174c. At least two sides, such as the sides 174a and 174b, are configured to be reflective so that the beam-deflecting element 172 is configured to be reflective on two sides. The sides 174a and 174b may be main sides of the beam-deflecting element 172, i.e., sides with a surface that is larger than the side 174c.

In other words, the beam-deflecting element 172 may be formed to be wedge-shaped and to be reflective on two sides. A further surface that is, however, substantially smaller than the surface 174c may be arranged opposite to the surface 174c, i.e., between the surfaces 174a and 174b. In other words, the wedge that is formed by the surfaces 174a, 174b and 174c does not arbitrarily taper, but is provided with a surface at the pointed side and is therefore dull.

30

Fig. 6b shows a schematic side-sectional view of the beam-deflecting element 172, wherein a suspension or a displacement axis 176 of the beam-deflecting element 172 is described. The displacement axis 176 around which the beam-deflecting element 172 may be movable in the beam-deflecting means 18 in a rotational and/or translational manner may be displaced

- 24 -

eccentrically with respect to a surface center of gravity 178 of the cross-section. Alternatively, the surface center of gravity may also be a point that describes half of the dimension of the beam-deflecting element 172 along a thickness direction 182 and along a direction 184 perpendicular thereto.

5

The main side 174a may comprise a surface normal 175a, while the main side 174b may comprise a surface normal 175b. If a rotational movement around the displacement axis 176 is used in order to switch between the first position and the second position of the beam-deflecting means, the rotational movement of the beam-deflecting means may be executed such that an orientation according to which one of the main sides 174a and 174b entirely faces the array 14 is avoided between the two positions, as is described in connection with Fig. 2b. This may also be understood such that, during a change between the first and the second operational state or position by the rotational movement, the surface normal 175a and the surface normal 175b of the second main side may comprise at each point in time an angle which is denoted in Fig. 2b as angle γ_1 and γ_2 of at least 10° with respect to a direction towards the image sensor and, if applicable, in parallel to a surface normal of the image sensor. With this, it may be avoided that one of the angles is 0° or 180° , which may represent a large or approximately maximum expansion of the beam-deflecting means along the thickness direction.

20 For example, the displacement axis 176 may be unchanged along a thickness direction 182 and may comprise any offset in a direction perpendicular thereto. Alternatively, an offset along the thickness direction 182 is also conceivable. For example, the displacement may be carried out such that, upon a rotation of the beam-deflecting element 172 around the displacement axis 176, a larger actuator travel is obtained than upon a rotation around the surface center of gravity 178. In this way, due to the displacement of the displacement axis 176, the distance around which the edge between the sides 174a and 174b is moved upon a rotation may increase at the same rotation angle compared with a rotation around the surface center of gravity 178. Preferably, the beam-deflecting element 172 is arranged such that the edge, i.e., the pointed side of the wedge-shaped cross-section, between the sides 174a and 174b faces the image sensor. Thus, due to small rotational movements, a different side 174a or 174b, respectively, may deflect the optical path of the optical channels. This makes it clear that the rotation may be executed such that a space requirement of the beam-deflecting means is small along the thickness direction 182 since a movement of the beam-deflecting element 172 in a way that a main side is perpendicular to the image sensor is not required.

30

The side 174c may also be referred to as secondary side or rear side. Several beam-deflecting elements may be connected to each other in such a way that a connecting element is arranged at the side 174c or extends through the cross-section of the beam-deflecting elements, i.e., is arranged in the interior of the beam-deflecting elements, e.g., in the area of the displacement axis 176. In particular, the holding element may be arranged such that the same does not extend beyond the beam-deflecting elements 172 along the direction 182 or solely to a small extent, i.e., not more than 50 %, not more than 30 % or not more than 10 %, so that the holding element does not increase or determine the expansion of the total structure along the direction 182. Alternatively, the expansion in the thickness direction 182 may be determined by the lenses of the optical channels, i.e., the same comprise the dimension defining the minimum of the thickness.

The beam-deflecting element 172 may be formed of glass, ceramics, glass ceramics, plastics, metal or any combination of these materials and/or further materials.

In other words, the beam-deflecting element 172 may be arranged such that the tip, i.e., the edge between the main sides 174a and 174b points towards the image sensor. Holding the beam-deflecting elements may be carried out such that it is solely carried out at the rear side or in the interior of the beam-deflecting elements, i.e., the main sides are not covered. A mutual holding or connecting element may extend across the rear side 174c. The rotation axis of the beam-deflecting element 172 may be arranged eccentrically.

Fig. 6c shows a schematic perspective view of a multi-aperture imaging device 190 including an image sensor 12 and a single-line array 14 of optical channels 16a-d arranged next to each other. The beam-deflecting means 18 includes a number of beam-deflecting elements 172a-d that may correspond to the number of optical channels. Alternatively, a smaller number of beam-deflecting elements may be arranged, e.g., if at least one beam-deflecting element is used by two optical channels. Alternatively, a larger number may also be arranged, e.g., if switching the deflecting direction of the beam-deflecting means 18 is carried out by a translational movement, as is described in connection with Figs. 5a and 5b. Each beam-deflecting element 172a-d may be associated with an optical channel 16a-d. The beam-deflecting elements 172a-d may be formed as a multitude of elements 172. Alternatively, at

least two, several or all beam-deflecting elements 172a-d may be formed integrally with each other.

5 Fig. 6d shows a schematic side-sectional view of the beam-deflecting element 172 having a cross section formed as a free-form surface. In this way, the side 174c may comprise a recess 186 that enables fixing a holding element, wherein the recess 186 may also be formed as a projecting element, e.g., a spring of a tongue-spring system. The cross section further comprises a fourth side 174d comprising a smaller surface expansion than the main sides 174a and 174b and connecting the same with each other.

10 Fig. 6e shows a schematic side-sectional view of a first beam-deflecting element 172a and a second beam-deflecting element 172b that is located behind the former in the illustration direction. The recesses 186a and 186b may be arranged such that the same are essentially congruent so that an arrangement of a connecting element in the recesses is possible.

15 Fig. 6f shows a schematic perspective view of a beam-deflecting means 18, e.g., including four beam-deflecting elements 172a-d that are connected with a connecting element 188. The connecting element may be usable in order to be movable by an actuator in a translational and/or rotational manner. The connecting element 188 may be configured to be integral and may extend across an extension direction, e.g., the y direction, at or in the beam-deflecting elements 172a-d. Alternatively, the connecting element 188 may solely be connected with at least one side of the beam-deflecting means 18, e.g., if the beam-deflecting elements 172a-d are formed to be integral. Alternatively, a connection to an actuator and/or a connection of the beam-deflecting elements 172a-d may also be carried out in any other way, e.g., by means of
20
25 adhesion, blasting or soldering.

Fig. 7 shows a schematic perspective illustration of an imaging system 60 according to an embodiment. The imaging system 60 includes the multi-aperture imaging device 10. According to further embodiments, alternatively or additionally to the multi-aperture imaging device 10, the imaging system 60 includes at least one multi-aperture imaging device 10', 20, 30, 40. The imaging system 60 includes a flat housing 92. The flat housing 92 includes a first expansion 94a along a first housing direction a. The flat housing 92 further includes a second expansion 94b along a second housing direction b and a third expansion 94c along a third housing direction c. For example, the housing direction a may be arranged in parallel to the thickness direction 57 in

- 27 -

the space. The expansion 94a of the flat housing 92 along the housing direction a may be understood as the smallest dimension of the flat housing 92. Compared to the smallest expansion, the other expansions 94b and/or 94c along the other housing directions b and c, respectively, may comprise a size of at least three times, a size of at least five times or a size of
5 at least seven times, in comparison to the expansion 94a along the housing direction a. Simply put, the expansion 94a may be smaller than, significantly smaller than or, if applicable, smaller by a magnitude than the other expansions 94b and 94c along the other housing directions b and c, respectively.

10 The flat housing 92 may include one or several diaphragms 96a-b through which the optical path 26 and/or 26' may be deflected, e.g., based on the beam-deflecting means of the multi-aperture imaging device 10. For example, the diaphragms may be electrochromic diaphragms and/or may be arranged in an area of the display.

15 The imaging system 60 may be configured as a portable device. For example, the imaging system 60 may be a portable communication means such as a mobile telephone or a so-called smartphone, a tablet computer or a portable music playing device. The imaging system 60 may be implemented as a screen, e.g., to be used in a navigation system, multimedia system or television system. Alternatively or additionally, the imaging system 60 may also be arranged
20 behind reflecting surfaces such as a mirror.

In the field of mobile communication devices, an arrangement of a multi-aperture imaging device 10, 10', 20, 30 and/or 40 may be advantageous since, based on the arrangement of the components along the long housing sides 94b and/or 94c, an expansion of the multi-aperture
25 imaging device along the housing direction 94a may be small so that the imaging system 60 may comprise a small expansion 94a. In other words, a relative two-dimensional lateral movement of the image sensor and the objective that causes a two-dimensional angle change of the field of view in conventional systems (corresponds to scanning) may be replaced by a one-dimensional change of the view direction and a rotational movement. A one-dimensional
30 change of the view direction may be carried out by changing the orientation of the mirror (beam-deflecting means) with respect to the optical axis (line extension direction) of the imaging channels by bringing the rotatably supported mirror into another orientation, wherein the rotation axis of the mirror may extend perpendicularly and/or almost perpendicularly to the optical axes of the imaging channels. For adapting the view direction perpendicularly to the above-described

- 28 -

direction, the image sensor and/or the array objective (array of the optical channels) may be laterally moved towards each other. Due to the interplay of both movements, a two-dimensional optical image stabilization may be achieved.

- 5 In order to enable a small installation height, the components (e.g., actuators) and sub-systems such as an image processor that are arranged for realizing the movement, may be arranged, if applicable, exclusively next to, in front of and/or behind the installation space defined by the imaging optical path, i.e., arranged between the planes 52a and 52b, and according to
10 embodiments, may not be arranged above or below the same. This enables a spatial separation of movement units (actuators) for the optical image stabilization. By this, a decrease of the number of necessary components may be obtained, and, thus, a manufacturing price of camera systems may be low, and a significant decrease of the installation height may be achieved in comparison to conventional structures. With reference to Fig. 2a, a difference to known systems may be the fact that the lenses (optics) of the optical channels may essentially define the
15 distance between the planes 52a and 52b. This enables a small installation height of the device, which is advantageous. In conventional systems, a main plane of the lenses is parallel to the planes 52a and 52b, whereas the main plane of the optics of the array is arranged orthogonally thereto.
- 20 Fig. 8 shows a schematic perspective view of a device 80 including a housing 72 and a first multi-aperture imaging device 10a and a second multi-aperture imaging device 10b arranged in the housing 72. The device 80 is configured to at least partially capture the total field of view 70, e.g., in the overlapping area of the capturing areas, in a stereoscopic manner with the multi-aperture imaging devices. For example, the total field of view 70 is arranged at a main side 74b
25 of the housing, which faces away from the main side 74a. For example, the multi-aperture imaging devices 10a and 10b may capture the total field of view 70 through transparent areas 68a and 68c, respectively, wherein diaphragms 78a and 78c arranged in the main side 74b are at least partially transparent. Diaphragms 78b and 78d arranged in the main side 74a may at least partially optically close the transparent areas 68b and 68d, respectively, so that an extent
30 of stray light from a side facing the main side 74a, which may falsify the captured images of the multi-aperture imaging devices 10a and/or 10b, is at least reduced. Although the multi-aperture imaging devices 10a and 10b are illustrated to be arranged spatially spaced apart from each other, the multi-aperture imaging devices 10a and 10b may also be arranged to be spatially adjacent or to be combined. For example, the single-line arrays of the imaging devices 10a and

- 29 -

10b may be arranged next to each other or in parallel to each other. The single-line arrays may form lines with respect to each other, wherein each multi-aperture imaging device 10a and 10b comprises a single-line array. The imaging devices 10a and 10b may comprise a mutual beam-deflecting means and/or a mutual carrier 62 and/or a mutual image sensor 12. Alternatively or
5 additionally to the multi-aperture imaging device 10a and/or 10b, at least the multi-aperture imaging device 10, 10', 20, 30 and/or 40 may be arranged. Such mutual elements, e.g., the beam-deflecting means or the array, may be used by a mutual optical image stabilizer, e.g., since a movement of the beam-deflecting means may function as an optical image stabilization for optical channels of several modules. Accordingly, the optical image stabilizer may also be
10 mutually implemented for several modules and/or a mutual reference channel may be used for several modules.

The transparent areas 68a-d may additionally comprise a switchable diaphragm 78a-d that covers the optical structure in case the same is not used. The diaphragm 78a-d may include a
15 mechanically moved part. The movement of the mechanically moved part may be carried out by using an actuator, e.g., as is described for the actuators 36 and 45. Alternatively or additionally, the diaphragm 78a-d may be electrically drivable and may include an electrochromic layer or an electrochromic layer series, i.e., may be formed as an electrochromic diaphragm.

20 Fig. 9 shows a schematic structure including a first multi-aperture imaging device 10a and a second multi-aperture imaging device 10b, e.g., as may be arranged in the imaging system 80. The arrays 14a and 14b are formed in a single-line manner and form a mutual line. The image sensors 12a and 12b may be mounted on a mutual substrate and/or on a mutual circuit carrier such as a mutual circuit board or a mutual flex board. Alternatively, the image sensors 12a and
25 12b may also include substrates that are different from each other. Obviously, various combinations of these alternatives are also possible, e.g., multi-aperture imaging devices including a mutual image sensor, a mutual array and/or a mutual beam-deflecting means 18 as well as further multi-aperture imaging devices comprising separate components. A mutual image sensor, a mutual array and/or a mutual beam-deflecting means are advantageous in that
30 a movement of a respective component may be obtained with a high precision by driving a lower number of actuators, and a synchronization between actuators may be reduced or avoided. Furthermore, a high thermal stability may be obtained. Alternatively or additionally, other and/or different multi-aperture imaging devices 10, 10', 20, 30 and/or 40 may comprise a mutual array, a mutual image sensor and/or a mutual beam-deflecting means.

Fig. 10a is a schematic illustration of an initial situation of an implementation of the electronic image stabilization, e.g., as may be obtained by the imaging systems described herein, wherein the implementations with respect to the electronic image stabilization may also refer to individual multi-aperture imaging devices without having a limiting effect. In the embodiment described, the imaging system uses a mutual optical image stabilizer and a mutual electronic image stabilizer. Each module exemplarily comprises two optical channels 16a and 16b, and 16c and 16d, respectively, in order to image the total field of view with an object 71. Without having a limiting effect, the images 73a and 73b of the optical channels 16a and 16b in the associated image sensor areas are referred to as left image 75a and the images 73c and 73d of the optical channels 16c and 16d are referred to as right image of a stereoscopic capturing of the object 71.

Fig. 10a shows an aberration-free state in which the object 71 is projected on the image sensor areas in order to obtain the images 73a-d. The images 73a and 73b may be combined by the multi-aperture imaging device to a left total image 77a, e.g., by means of a stitching. The images 73c and 73d may be combined in a similar manner by the multi-aperture imaging device to a right total image 77b so that stereoscopic information with respect to the object 71 may be determined through the two total images 75a and 75b.

Now, Fig. 10b shows the case of Fig. 10a, in which a relative movement of the imaging system with respect to the object 71 leads to a changed relative position of the object 71, which is illustrated by the object 71'. For example, this may be a movement of the object 71 and/or shaking of the imaging system. When neglecting image corrections, the relative movement now leads to a changed image position of the image of the object 71 in the image sensor areas, which is illustrated by the dotted lines of the images 73'a-d.

Now, obtaining images 77a and 77b that are illustrated in Fig. 10a, i.e., aberration-compensated images, is what is strived for. A compensation of the shaking, i.e., a best possible image stabilization, is what is strived for. Deviations in the optics of the optical channels are not taken into account in this consideration.

Fig. 10c shows the basis for the optical image stabilization in the images under the unchanged assumption that a purely optical image stabilization of all optical channels that comprise

- 31 -

identical optical parameters, i.e., that comprise an identical focal length, leads to a best possible image stabilization. The displacement of the object 71 is illustrated by an arrow 79 that points in a positive direction 28 and in a negative direction 32. By generating the relative movement between the image sensor, the array and the beam-deflecting means by the optical image stabilizer, it is achieved that the images 73'a-d and, therefore, the total images 77a and 77b are displaced along opposing directions 82a-d and 84a-b, respectively, wherein, when operating, the displacement of the object according to Fig. 10b and also the compensation according to Fig. 10c are carried out in a timely manner in order to avoid the creation of the illustrated offset. The directions represented by the arrows 84a-d and 77a-b are arranged opposite to the arrow 79 in the space, e.g., at significant points in the respective partial image, e.g., an eye or corner of the mouth, e.g., which indicates edges in the image.

Now, Fig. 10d illustrates obtained partial images 73''a-d after the optical image stabilization and under consideration of the actual deviations in the optical characteristics. For example, the optical image stabilization is executed such that the image 73a is corrected in a best possible manner, which means that the optically-stabilized image 73''a corresponds to the aberration-free image 73a, at least in a tolerance range that indicates the possibilities of the optical image stabilizer.

Due to the deviations in the optical characteristics, the image stabilization in the optical channel 16a now has different effects in the channels 16b-d, which means that the deviations in the optical characteristics cause, e.g., that the arrows 82a-d indicating the displacement of the images based on the optical stabilization may be different with respect to the length and/or the direction.

This is notable in the joined images 77 that are formed from the corrected images 73''a and 73''b, and 73''c and 73''d, respectively. The divergence in the displacement back due to the optical image stabilization leads to the fact that the partial images fall apart, which may cause errors when stitching. For example, this is illustrated by the separated partial images 73''c and 73''d in connection with the total image 77b, or by the partial image 73''b in the total image 77a, which is spaced apart from the partial image 73''a that is correctly stabilized. In other words, aberrations occur when joining the image since there is an image position in all channels that is not entirely compensated.

- 32 -

In the images of the channels 16b-c, Fig. 10e shows the optical image stabilization, which is indicated by the images 73''b-d, that is performed with respect to the reference channel 16a. By electronic image stabilization in the channels 16b-d away from the channel 16a, their deviations with respect to the optical image stabilization in the optical channel 16a are at least partially compensated so that aberration-reduced or even aberration-free images 77''a and 77''b may be obtained, which may correspond to the images 77a and 77b, respectively. This means that partially-compensated image locations are obtained through the optical image stabilization and compensated image positions are obtained through the additional electronic image stabilization. The extent of the electronic image stabilization may be carried out by the electronic image stabilizer using the functional connection between the optical channels 16a-d. Alternatively or additionally, the electronic image stabilizer, e.g., the image stabilizer 41, may be configured to determine the extent of the displacement in the images, e.g., when considering a matching feature in two frames that are temporally different from each other or that succeed each other.

Fig. 11 shows a schematic flow diagram of a method 1100 for providing a multi-aperture imaging device. Step 1110 comprises providing an image sensor. Step 1120 comprises providing an array of optical channels so that each optical channel includes an optic for projecting a partial field of view of a total field of view on an image sensor area of the image sensor. Step 1130 comprises arranging a beam-deflecting means for deflecting an optical path of the optical channels. Step 1140 comprises arranging an optical image stabilizer for the image stabilization along a first image axis by generating a first relative movement between the image sensor, the array and the beam-deflecting means and for the image stabilization along a second image axis by generating a second relative movement between the image sensor, the array and the beam-deflecting means. Step 1150 comprises arranging an electronic image stabilizer for the image stabilization of a first optical channel of the array along the first and the second image axis.

Embodiments described herein enable multi-aperture imaging systems having a linear channel arrangement, i.e., in a single line or in multiple lines along a line extension direction, having an optical image stabilization using a single-axis translational movement between an image sensor and an imaging optic, and a single-axis rotational movement of a beam-deflecting mirror array.

Although embodiments described above have been described such that a number of four optical channels or a multitude thereof is arranged, multi-aperture imaging devices according to further

- 33 -

embodiments may include any number of optical channels, e.g., at least two, at least three, at least four, at least ten or a higher number of optical channels may be arranged.

5 Although above-described embodiments have been described such that the optical image stabilizer 22 includes the actuator 36 and the actuator 42, according to further embodiments, the actuators 36 and 42 may also be configured as a mutual actuator. For example, a movement generated by the actuator may be directed on to the image sensor 12, the optical array 14 and/or the beam-deflecting means 18 by means of a force converter and/or distance converter (transmission) in order to obtain a respective movement. Alternatively or additionally, one or
10 several components may also be moved by several actuators, e.g., as is described in connection with the multi-aperture imaging device 40.

For example, the image sensor may be configured as a complementary metal-oxide-semiconductor (CMOS) or as a technology different thereto. The optical channels of a
15 respective array may be understood such that the same define an area in which an optical path that is directed onto a respective image sensor area is optically changed. Thus, an optical path associated with an image sensor area may travel through the optical channel of the array.

It has been pointed out above that the optical paths and/or the optical axes may be directed,
20 starting from the beam-deflecting means, in different directions. This may be obtained by directing the optical paths, during a deflection at the beam-deflecting means and/or by the optics, in a manner that deviates from a parallelism with respect to each other. The optical paths and/or the optical axes may deviate from a parallelism before and/or without a beam-deflection. In the following, this fact is described in that the channels may be provided with a type of pre-
25 divergence. With this pre-divergence of the optical axes, it would be possible, e.g., that not all facets inclinations of facets of the beam-deflecting means differ from each other, but that some groups of channels, e.g., have the facets with the same inclination or are directed thereto. The latter may be formed as a single piece and/or continuously merging into each other, i.e., as a facet that is assigned to this group of channels neighboring in the line extension direction. The
30 divergence of the optical axes of these channels could then come from the divergence of these optical axes, as it is obtained by a lateral offset between optical centers of the optics of the optical channels and image sensor areas of the channels. For example, the pre-divergence could be limited to one plane. For example, the optical axes could extend in a common plane before and/or without a beam-deflection, however, extending in a divergent manner in this

- 34 -

plane, and the facets solely causing an additional divergence in the other transversal plane, i.e., the same are all inclined in parallel to the line extension direction and differently with respect to the above-mentioned mutual plane of the optical axes, wherein, in turn, several facets may have the same inclination and/or could be mutually associated with a group of channels whose optical axes already differ, e.g., in pairs in the above-mentioned mutual plane of the optical axes before and/or without a beam-deflection. Simply put, the optics may enable a (pre-) divergence of the optical paths along a first (image) direction and the beam-deflecting means may enable a divergence of the optical paths along a second (image) direction.

10 For example, the above-mentioned possibly present pre-divergence may be achieved by placing the optical centers of the optics on a straight line along the line extension direction, while the centers of the image center areas are arranged to deviate from the projection of the optical centers along the normal of the plane of the image sensor areas onto points on a straight line in the image sensor plane, e.g., at points that deviate from the points on the above-mentioned straight line in the image sensor plane in a channel-individual manner along the line extension direction and/or along the direction perpendicular both to the line extension direction and also to the image sensor normal. Alternatively, a pre-divergence may be achieved by placing the centers of the image sensors on a straight line along the line extension direction, while the centers of the optics are arranged to deviate from the projection of the optical centers of the image sensors along the normal of the plane of the optical centers of the optics onto points on a straight line in the optic center plane, e.g., at points that deviate from the points on the above-mentioned straight line in the optic center plane in a channel-individual manner along the line extension direction and/or along the direction perpendicular both to the line extension direction and also to the normal of the optic center plane. It is preferred that the above-mentioned channel-individual deviation from the respective projection extends solely in the line extension direction, i.e., that the optical axes are solely located in a mutual plane and are provided with a pre-divergence. The optical centers and also the image sensor area centers are then each located on a straight line parallel to the line extension direction, however, having different intermediate distances. In contrast, a lateral offset between lenses and image sensors in a lateral direction perpendicular to the line extension direction led to an increase in the installation height. A purely in-plane offset in the line extension direction does not change the installation height, however, as a result there may possibly be fewer facets and/or the facets only comprise a tilt in an angle orientation, which simplifies the structure. Thus, e.g., neighboring optical channels may each comprise optical axes that extend in the same plane, that each squint with

- 35 -

respect to each other, i.e., that are provided with a pre-divergence. A facet may be arranged with respect to a group of optical channels, may solely be inclined in a direction and may be parallel to the line extension direction.

5 Furthermore, it could be provided that some optical channels are associated to the same partial field of view, e.g., for the purpose of super resolution or to increase the resolution with which the corresponding partial field of view is scanned by means of these channels. Before a beam-deflection, the optical channel in such a group would then extend in parallel and would be deflected by a facet on a partial field of view. Advantageously, pixel images of the image sensor
10 of a channel of a group would be located in an intermediate position between images of the pixels of the image sensor of a different channel of this group.

For example, without the purpose of super resolution, however, solely for the purpose of stereoscopy, an implementation would also be conceivable, in which a group of immediately
15 neighboring channels in the line extension direction cover the total field of view entirely with their partial fields of view and that a further group of immediately neighboring channels entirely cover the total field of view on their part.

Thus, the above embodiments may be implemented in form of a multi-aperture imaging device
20 and/or an imaging system including such a multi-aperture imaging device, namely with a single line channel arrangement, wherein each channel transmits a partial field of view of a total field of view and the partial fields of view partially overlap. A structure having several such multi-aperture imaging devices for stereo structures, trio structures, quartet structures, etc., for the capturing 3D images is possible. The plurality of modules may be implemented as a joined line.
25 The joined line could use identical actuators and a mutual beam-deflecting element. One or several amplifying substrates possibly present in the optical path could extend across the entire line that may form a stereo structure, trio structure, quattro structure. Methods of super resolution may be used, wherein several channels image the same partial image areas. The optical axes may also extend in a divergent manner without a beam-deflecting device so that
30 fewer facets are required on the beam-deflecting unit. Then, the facets advantageously include only one angle component. The image sensor may be a single piece, may comprise only one joined pixel matrix or several discontinuous pixel matrices. The image sensor may be composed of many partial sensors, e.g., that are arranged next to each other on a circuit board. An

- 36 -

autofocus drive may be implemented such that the beam-deflecting element is moved synchronously with the optics or such that the same is idle.

5 Even though some aspects have been described within the context of a device, it is understood that said aspects also represent a description of the corresponding method, so that a block or a structural component of a device is also to be understood as a corresponding method step or as a feature of a method step. By analogy therewith, aspects that have been described within the context of or as a method step also represent a description of a corresponding block or detail or feature of a corresponding device

10 The above-described embodiments merely represent an illustration of the principles of the present invention. It is understood that other persons skilled in the art will appreciate modifications and variations of the arrangements and details described herein. This is why it is intended that the invention be limited only by the scope of the following claims rather than by the specific details that have been presented herein by means of the description and the discussion of the embodiments.

15

Claims

1. Multi-aperture imaging device comprising:

5 an image sensor;

an array of optical channels, each optical channel including an optic for projecting a partial field of view of a total field of view on an image sensor area of the image sensor;

10 a beam-deflecting means for deflecting an optical path of the optical channels; and

an optical image stabilizer for the image stabilization along a first image axis by generating a first relative movement between the image sensor, the array and the beam-deflecting means and for the image stabilization along a second image axis by
15 generating a second relative movement between the image sensor, the array and the beam-deflecting means;

an electronic image stabilizer for the image stabilization along a first optical channel of the array along the first and the second image axis; further implemented for at least one
20 of:

wherein the optical image stabilizer is configured to execute the optical image stabilization such that the optical image stabilization for an image of a first of the partial fields of view as reference image is as exact as possible, wherein the electronic image
25 stabilizer is configured to stabilize an image of a second partial field of view based on the reference image of the optical image stabilizer;

wherein the optical image stabilizer is configured to stabilize an image of the imaged partial field of view of a reference channel of the optical channels, and wherein the
30 electronic image stabilizer is configured to execute, by means of channel-individual image evaluation of the movement of image details, an image stabilization in a channel-individual manner for optical channels that differ from the reference channel, wherein the multi-aperture imaging device is configured to stabilize the reference channel exclusively in an optical manner;

5 wherein the optical image stabilizer is configured to stabilize an image of the imaged partial field of view of a reference channel of the optical channels, and wherein the electronic image stabilizer is configured to execute an image stabilization in a channel- individual manner and differently from each other for optical channels that differ from the reference channel, wherein the multi-aperture imaging device is configured to stabilize the reference channel exclusively in an optical manner;

10 wherein the electronic image stabilizer is configured to execute, by means of channel- individual image evaluation of the movement of image details, an image stabilization for each optical channel in a channel- individual manner in order to correct channel- individual imaging errors;

15 wherein the electronic image stabilizer is configured to execute an image stabilization for each optical channel in a channel- individual manner and differently from each other in order to correct channel- individual imaging errors; wherein the electronic image stabilizer is configured to execute the channel- individual electronic image stabilization in each channel according to a determined functional connection that describes the channel- individual imaging error as a function of a respective focal length of optics of
20 the optical channel and of the relative movements between the image sensor, the array and the beam- deflecting means; or wherein the electronic image stabilizer is configured to identify, in a first partial image of a first partial field of view and in a second image of a second partial field of view, a matching feature, and to provide the electronic image stabilization based on a comparison of movements of the feature in the first and the
25 second image.

2. Multi-aperture imaging device according to claim 1, wherein the electronic image stabilizer is configured to stabilize the first optical channel and the second optical channel relative to a reference channel of the optical channels and/or by means of
30 channel- individual image evaluation of the movement of image details in a channel- individual manner and differently from each other along the first and the second image axis.

3. Multi-aperture imaging device according to any one of claims 1 or 2, wherein the
electronical image stabilizer is configured to execute, by means of channel-individual
image evaluation of the movement of image details, an image stabilization for each
5 optical channel in a channel-individual manner in order to correct channel-individual
imaging errors; or wherein the electronic image stabilizer is configured to execute an
image stabilization for each optical channel in a channel-individual manner and
differently from each other in order to correct channel-individual imaging errors; wherein
the channel-individual electronic image stabilization is executed by means of channel-
individual image evaluation of the movement of image details in the images of the partial
10 fields of view.
4. Multi-aperture imaging device according to any one of claims 1 to 3, wherein the
electronical image stabilizer is configured to execute, by means of channel-individual
image evaluation of the movement of image details, an image stabilization for each
15 optical channel in a channel-individual manner in order to correct channel-individual
imaging errors; or wherein the electronic image stabilizer is configured to execute an
image stabilization for each optical channel in a channel-individual manner and
differently from each other in order to correct channel-individual imaging errors; wherein
the electronic image stabilizer is configured to execute the channel-individual electronic
20 image stabilization in each channel according to a determined functional connection
that describes the channel-individual imaging error as a function of a respective focal
length of optics of the optical channel and of the relative movements between the image
sensor, the array and the beam-deflecting means.
- 25 5. Multi-aperture imaging device according to claim 4, wherein the functional connection
is a linear function.
6. Multi-aperture imaging device according to any one of claim 4 or 5, wherein the optical
image stabilizer is configured to provide the optical image stabilization along one of the
30 image directions based on a rotational movement of the beam-deflecting means,
wherein the functional connection is an angle function that projects a rotation angle of
the rotational movement of the beam-deflecting means on an extent of the electronic
image stabilization along the image direction.

7. Multi-aperture imaging device according to any one of claims 1 to 6, wherein the
electronical image stabilizer is configured to execute, by means of channel-individual
image evaluation of the movement of image details, an image stabilization for each
optical channel in a channel-individual manner in order to correct channel-individual
5 imaging errors; or wherein the electronic image stabilizer is configured to execute an
image stabilization for each optical channel in a channel-individual manner and
differently from each other in order to correct channel-individual imaging errors; wherein
the electronic image stabilizer is configured to identify in a first partial image of a first
partial field of view at a first point in time and at a second point in time, a matching
10 feature, and to provide the electronic image stabilization based on a comparison of
movements of the feature in the first image.
8. Multi-aperture imaging device according to any one of claims 1 to 7, wherein the focal
lengths of optics of different optical channels differ and a movement of beam-deflecting
15 means leads to differing changes of the projections on the image sensor areas, wherein
the electronic image stabilizer is configured to compensate differences between the
different changes of the projections by means of a channel-individual image stabilization
including a channel-individual image evaluation of the movement of image details.
- 20 9. Multi-aperture imaging device according to any one of claims 1 to 8, wherein the focal
lengths of optics of different optical channels differ, and a movement of the beam-
deflecting means leads to differing changes of the projections on the image sensor
areas, wherein the electronic image stabilizer is configured to compensate differences
between the different changes of the projections by means of a channel-individual and
25 differing image stabilization.
10. Multi-aperture imaging device according to any one of claims 1 to 9, wherein a first optic
that is associated with a first optical channel and a second optic that is associated with
a second optical channel are formed in the same manner in a tolerance range of not
30 more than 10%.
11. Multi-aperture imaging device according to any one of claims 1 to 10, wherein the first
relative movement includes at least one of a translational relative movement between
the image sensor and the array, a translational relative movement between the image

sensor and the beam-deflecting means and a translational relative movement between the array and the beam-deflecting means, and wherein the second relative movement includes at least one of a rotational movement of the beam-deflecting means, a translational relative movement between the image sensor and the array and a translational relative movement between the array and the beam-deflecting means.

5

12. Multi-aperture imaging device according to any one of claims 1 to 11, wherein the optical image stabilizer includes at least one actuator and is arranged such that it is at least partially arranged between two planes that are spanned by sides of a cuboid, wherein the sides of the cuboid are orientated in parallel to each other and to a line extension direction of the array and a part of the optical path of the optical channels between the image sensor and the optics, and the same has a minimal volume but still includes the image sensors and the array.

10

13. Multi-aperture imaging device according to claim 12, wherein the optical image stabilizer extends out of an area between the planes by not more than 50%.

15

14. Multi-aperture imaging device according to any one of claims 1 to 13, wherein the beam-deflecting means comprises a first main side and a second main side and is configured to, in a first operational state, direct optical paths of the optical channels in a first view direction of the multi-aperture imaging device with the first main side, and, in a second operational state, direct optical paths of the optical channels in a second view direction of the multi-aperture imaging device with the second main side.

20

15. Multi-aperture imaging device according to claim 14, wherein the first main side and the second main side are arranged to be inclined to each other at an angle of not more than 60°.

25

16. Multi-aperture imaging device according to any one of claim 14 or 15, configured to execute a switch between the first and the second operational state by a rotational movement, wherein, during the rotational movement, a first surface normal of the first main side and a second surface normal of the second main side comprise at each point in time an angle of at least 10° with respect to a direction towards the image sensor.

30

17. Multi-aperture imaging device according to any one of claims 1 to 16, configured to receive a sensor signal from a sensor, and to evaluate the sensor signal with respect to an information that correlates to a relative movement between the multi-aperture imaging device and the object, and to execute a control of the optical or electronic image stabilizer using the information.
- 5
18. Imaging system having a first and a second multi-aperture imaging device according to any one of claims 1 to 17, configured to capture a total field of view at least partially in a stereoscopic manner.
- 10
19. Method of providing a multi-aperture imaging device, comprising:
- providing an image sensor;
- 15 providing an array of optical channels such that each optical channel includes an optic for projecting a partial field of view of a total field of view on an image sensor area of the image sensor;
- arranging a beam-deflecting means for deflecting an optical path of the optical channels;
- 20 and
- arranging an optical image stabilizer for the image stabilization along a first image axis by generating a first relative movement between the image sensor, the array and the beam-deflecting means and for the image stabilization along a second image axis by
- 25 generating a second relative movement between the image sensor, the array and the beam-deflecting means;
- arranging an electronic image stabilizer for the image stabilization of a first optical channel of the array along the first and the second image axis; such that at least one of
- 30 the optical image stabilizer is configured to execute the optical image stabilization such that the optical image stabilization for an image of a first of the partial fields of view as reference image is as exact as possible, such that the electronic image stabilizer is

configured to stabilize an image of a second partial field of view based on the reference image of the optical image stabilizer;

5 the optical image stabilizer is configured to stabilize an image of the imaged partial field of view of a reference channel of the optical channels, and such that the electronic image stabilizer is configured to execute, by means of channel-individual image evaluation of the movement of image details, an image stabilization in a channel-individual manner for optical channels that differ from the reference channel, such that the multi-aperture imaging device is configured to stabilize the reference channel
10 exclusively in an optical manner;

the optical image stabilizer is configured to stabilize an image of the imaged partial field of view of a reference channel of the optical channels, and such that the electronic image stabilizer is configured to execute an image stabilization in a channel-individual
15 manner and differently from each other for optical channels that differ from the reference channel, such that the multi-aperture imaging device is configured to stabilize the reference channel exclusively in an optical manner;

the electronic image stabilizer is configured to execute, by means of channel-individual image evaluation of the movement of image details, an image stabilization for each optical channel in a channel-individual manner in order to correct channel-individual imaging errors;
20

the electronic image stabilizer is configured to execute an image stabilization for each optical channel in a channel-individual manner and differently from each other in order to correct channel-individual imaging errors; such that the electronic image stabilizer is configured to execute the channel-individual electronic image stabilization in each channel according to a determined functional connection that describes the channel-individual imaging error as a function of a respective focal length of optics of the optical channel and of the relative movements between the image sensor, the array and the beam-deflecting means; or such that the electronic image stabilizer is configured to identify, in a first partial image of a first partial field of view and in a second image of a second partial field of view, a matching feature, and to provide the electronic image
25
30

stabilization based on a comparison of movements of the feature in the first and the second image.

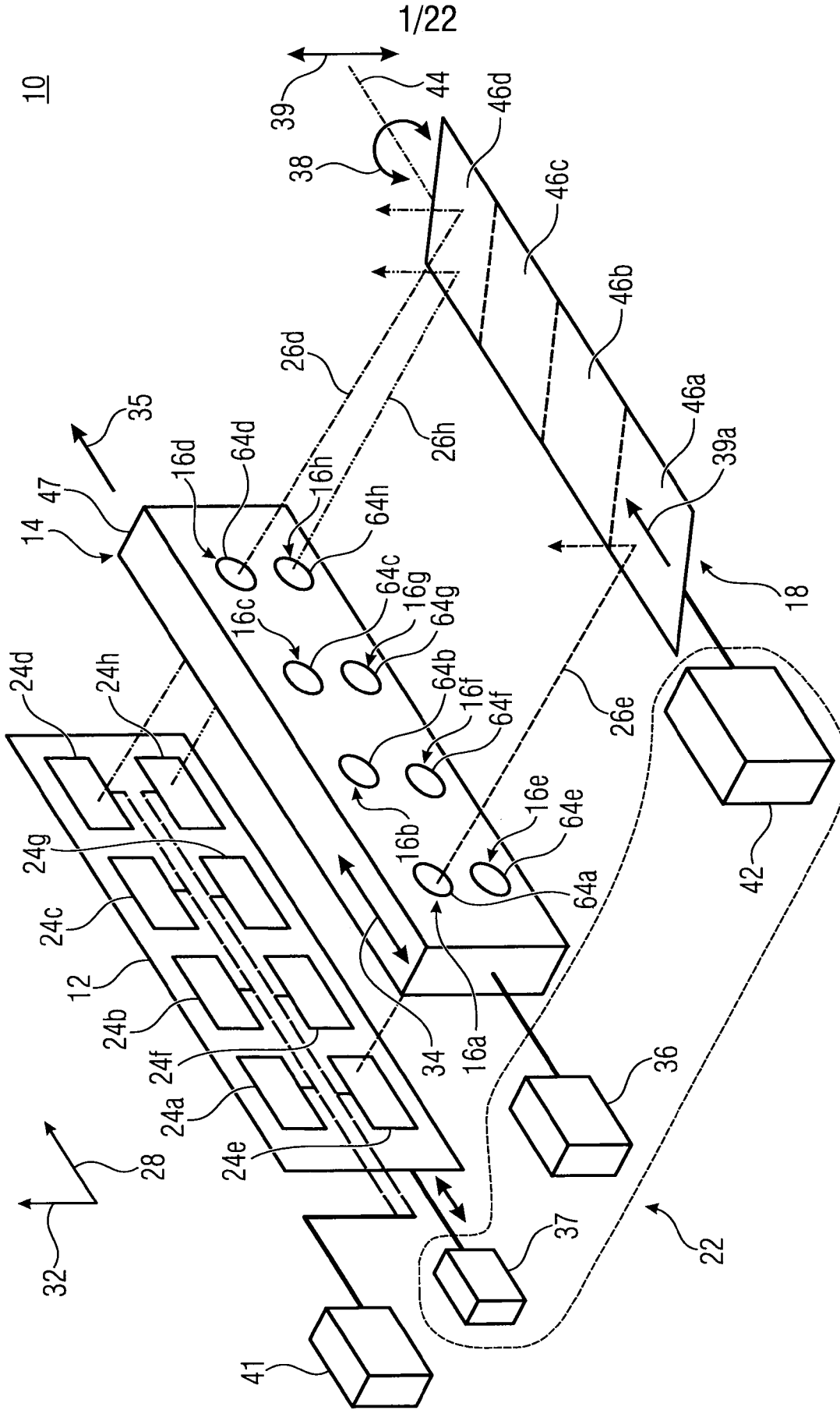

Fig. 1a

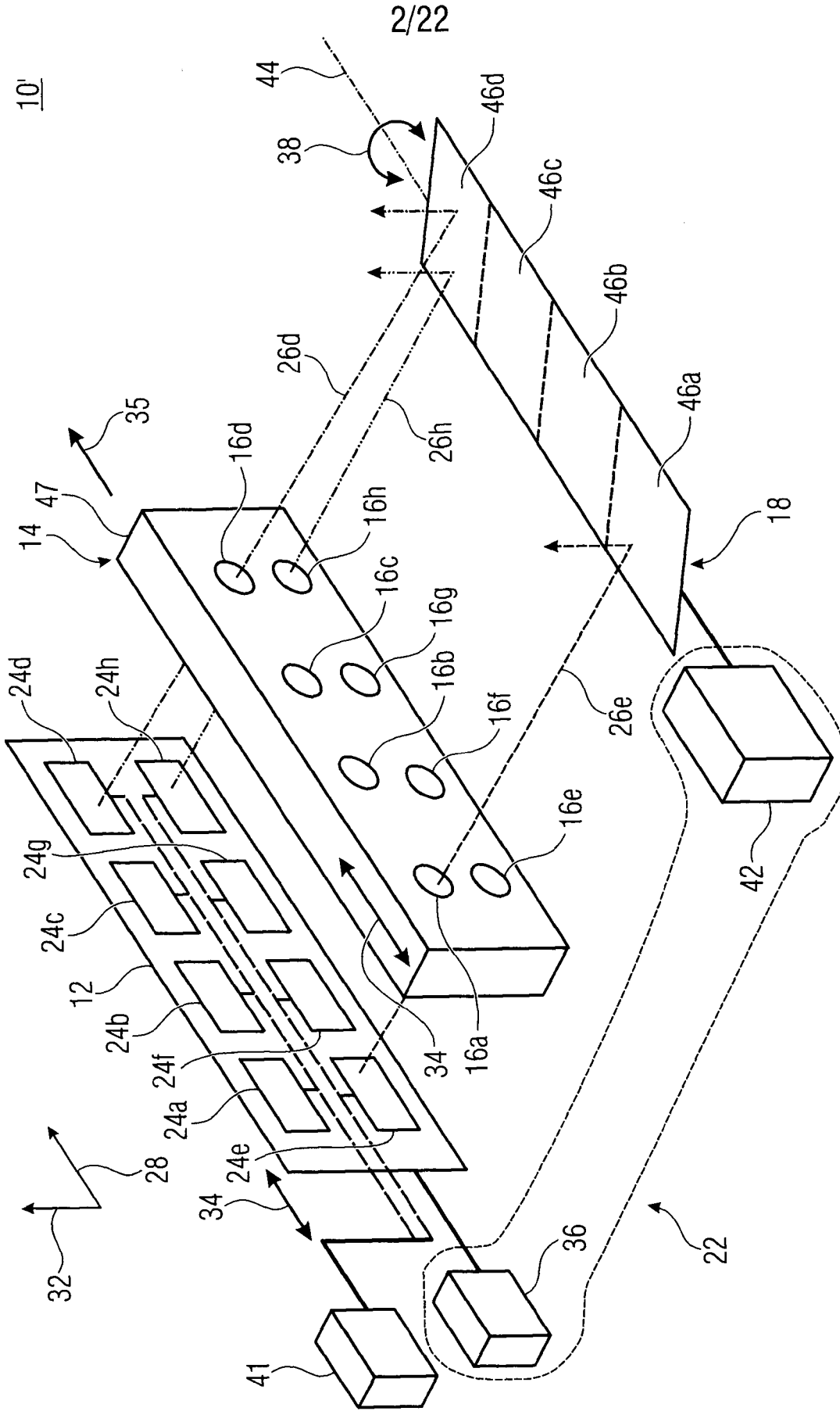

Fig. 1b

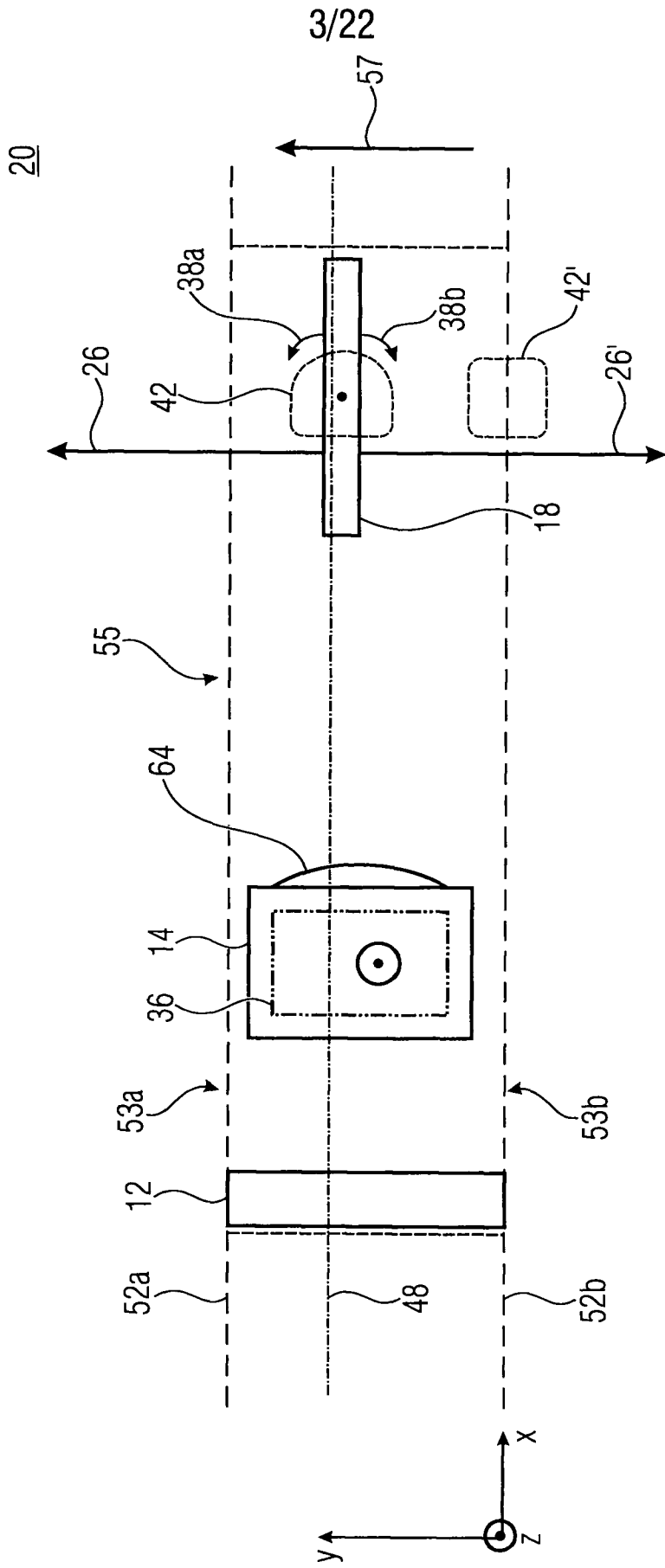

Fig. 2a

20

4/22

20

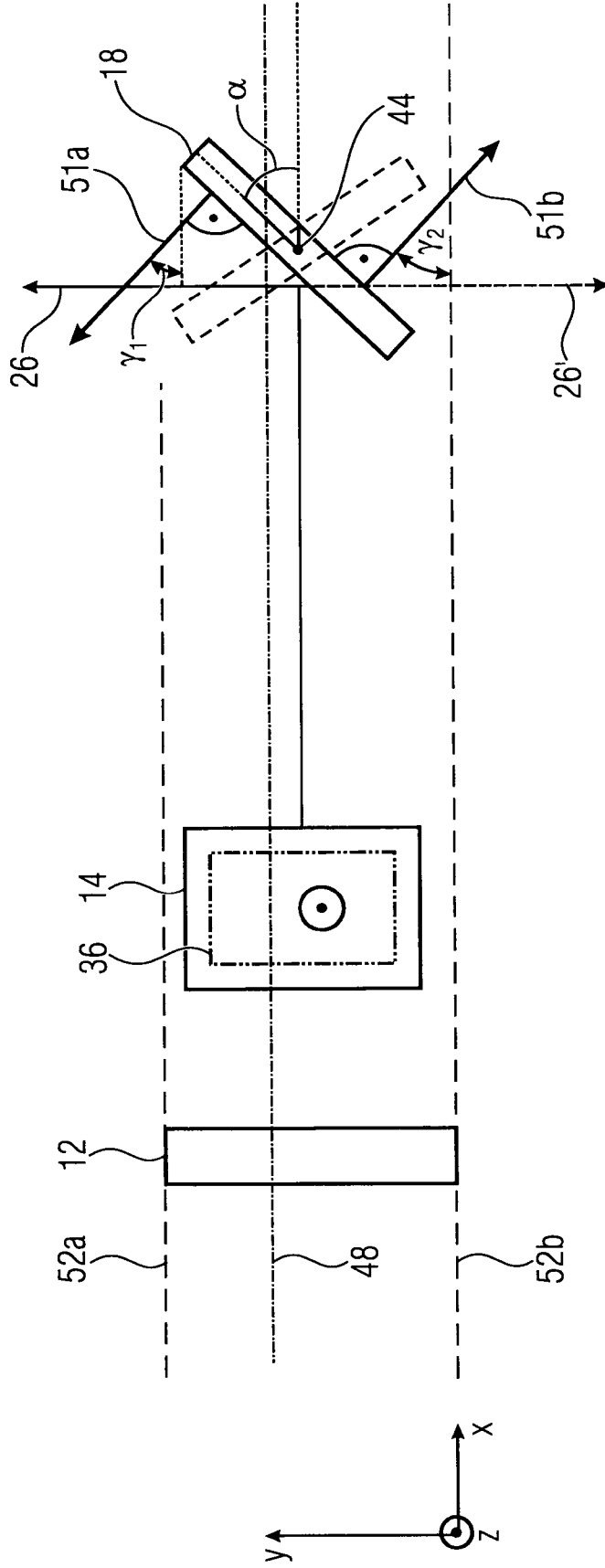

Fig. 2b

5/22

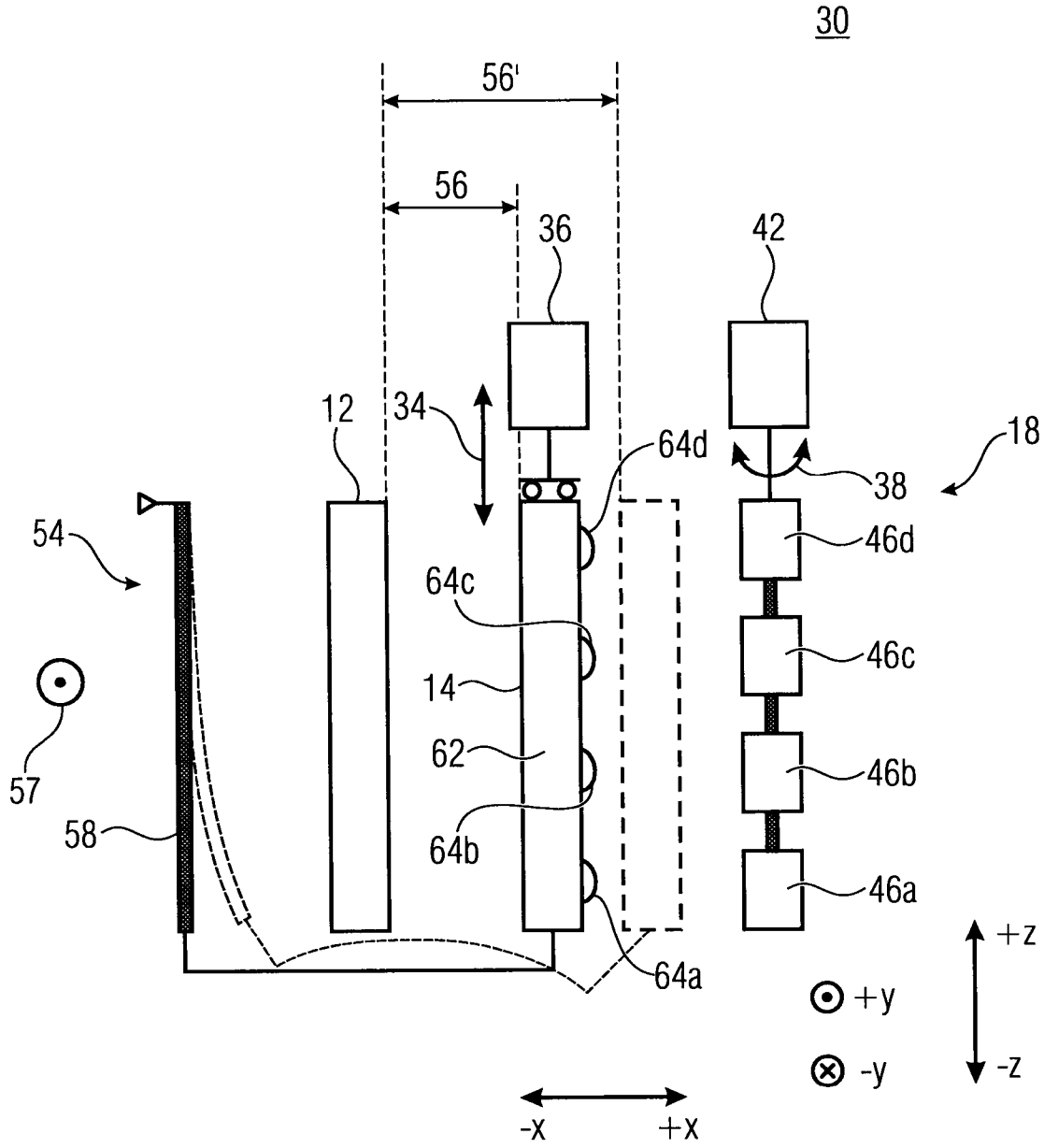

Fig. 3

6/22

40

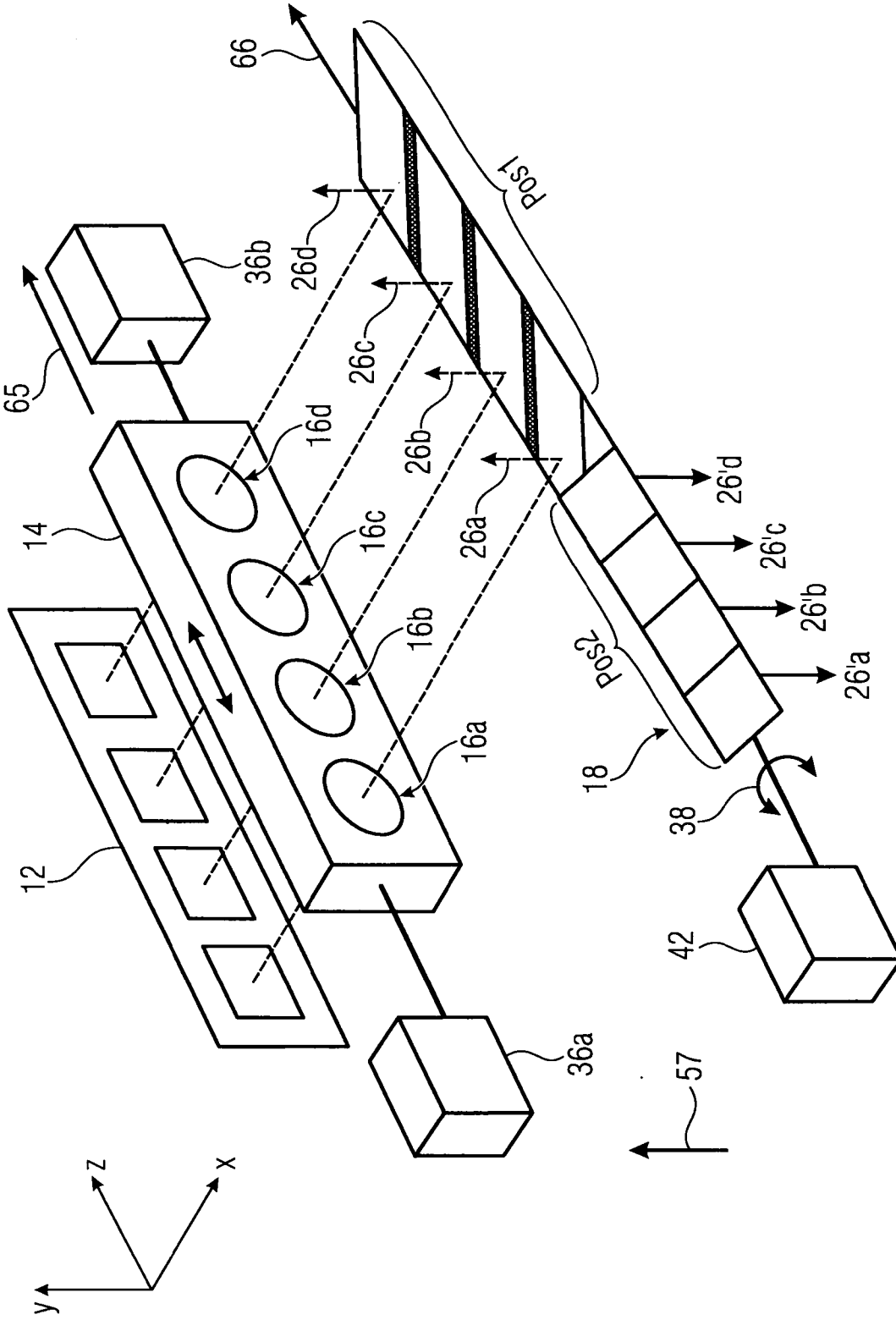

Fig. 4a

7/22

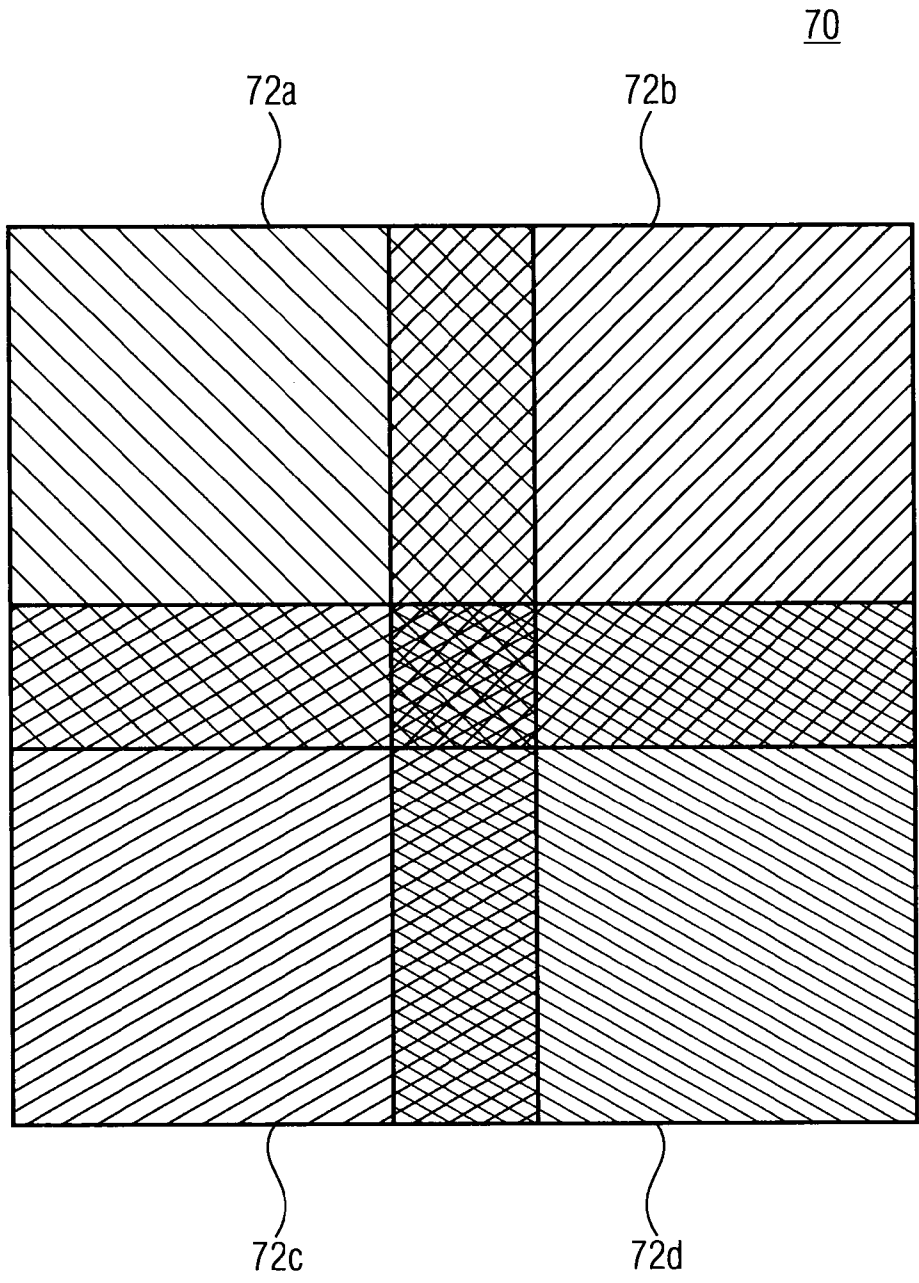

Fig. 4b

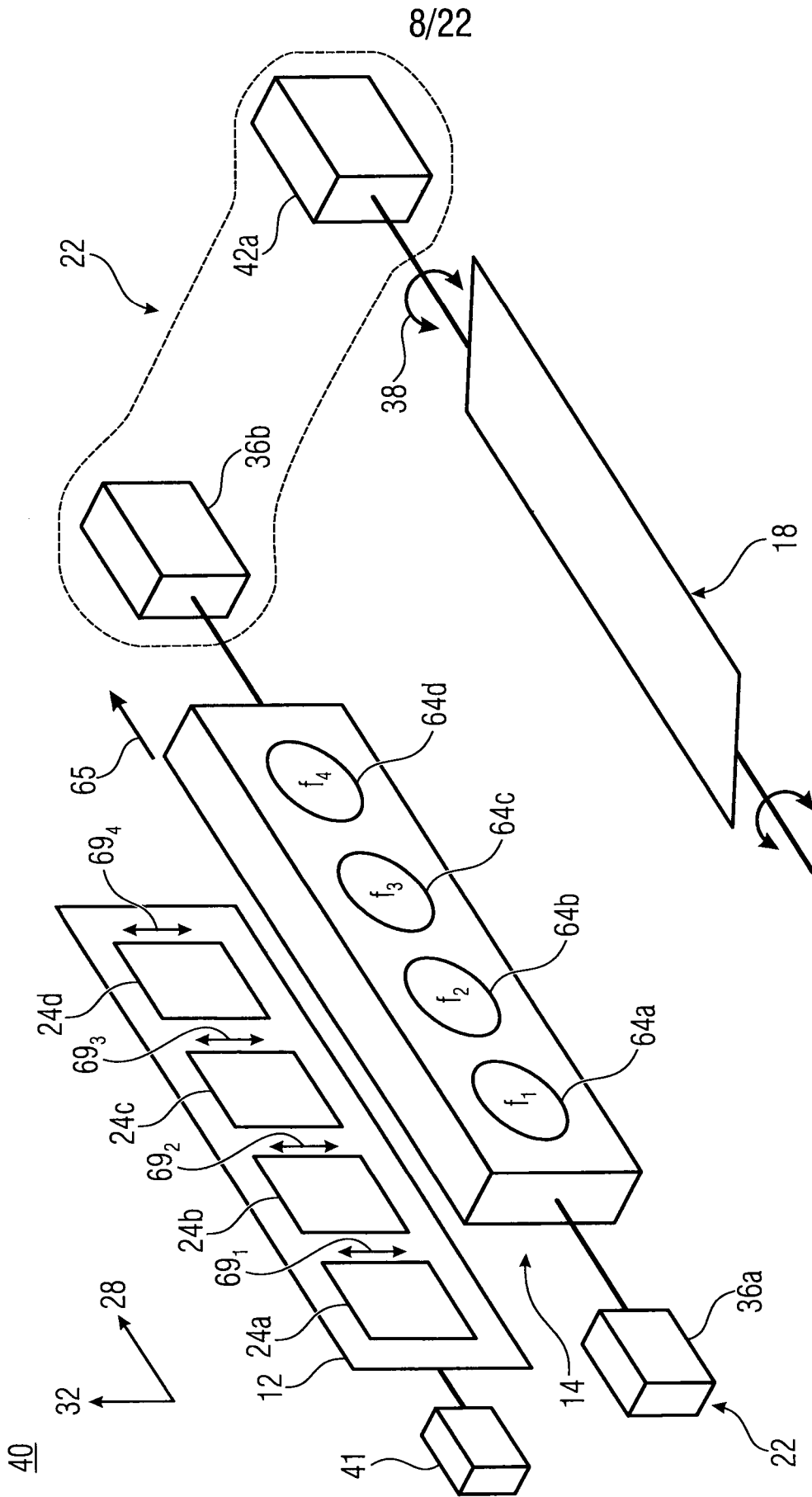
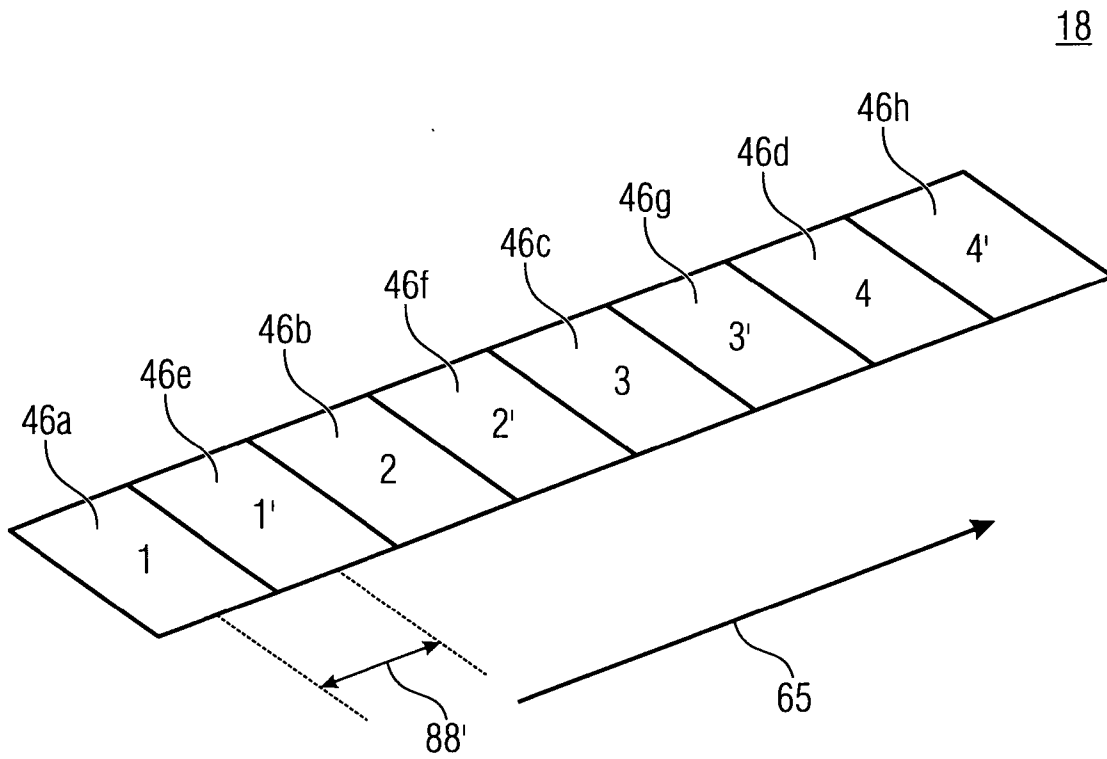
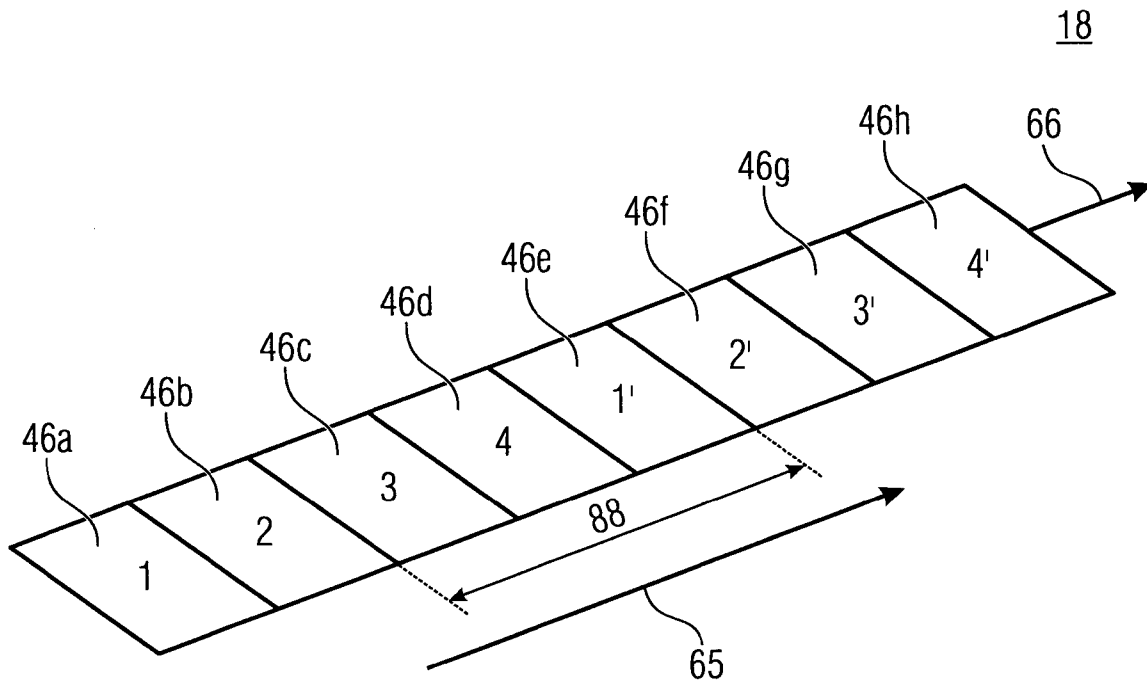

Fig. 4C

9/22



10/22

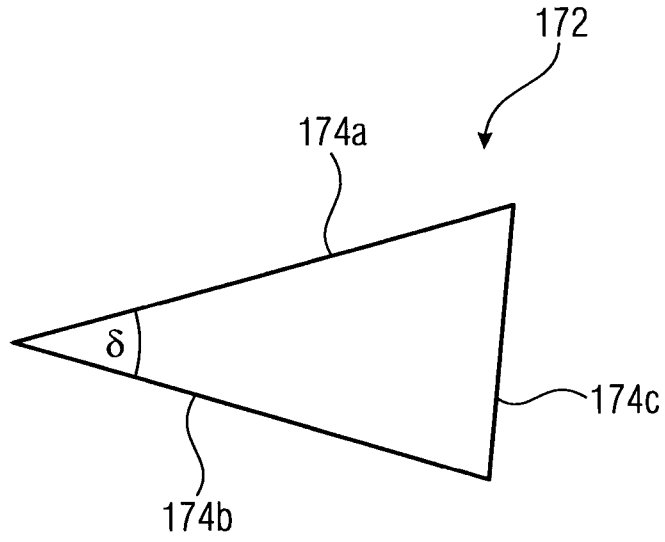

Fig. 6a

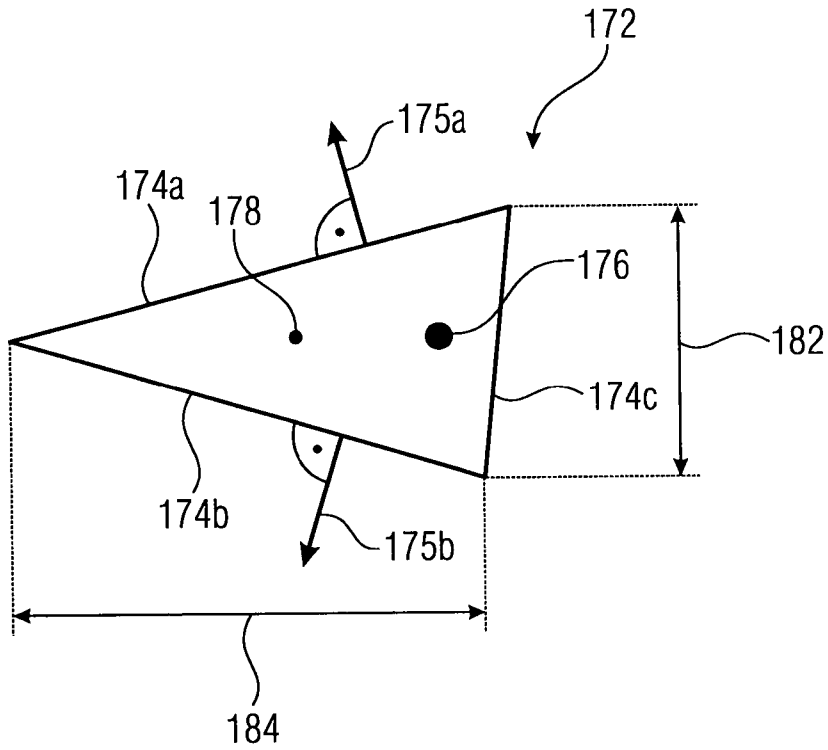

Fig. 6b

11/22

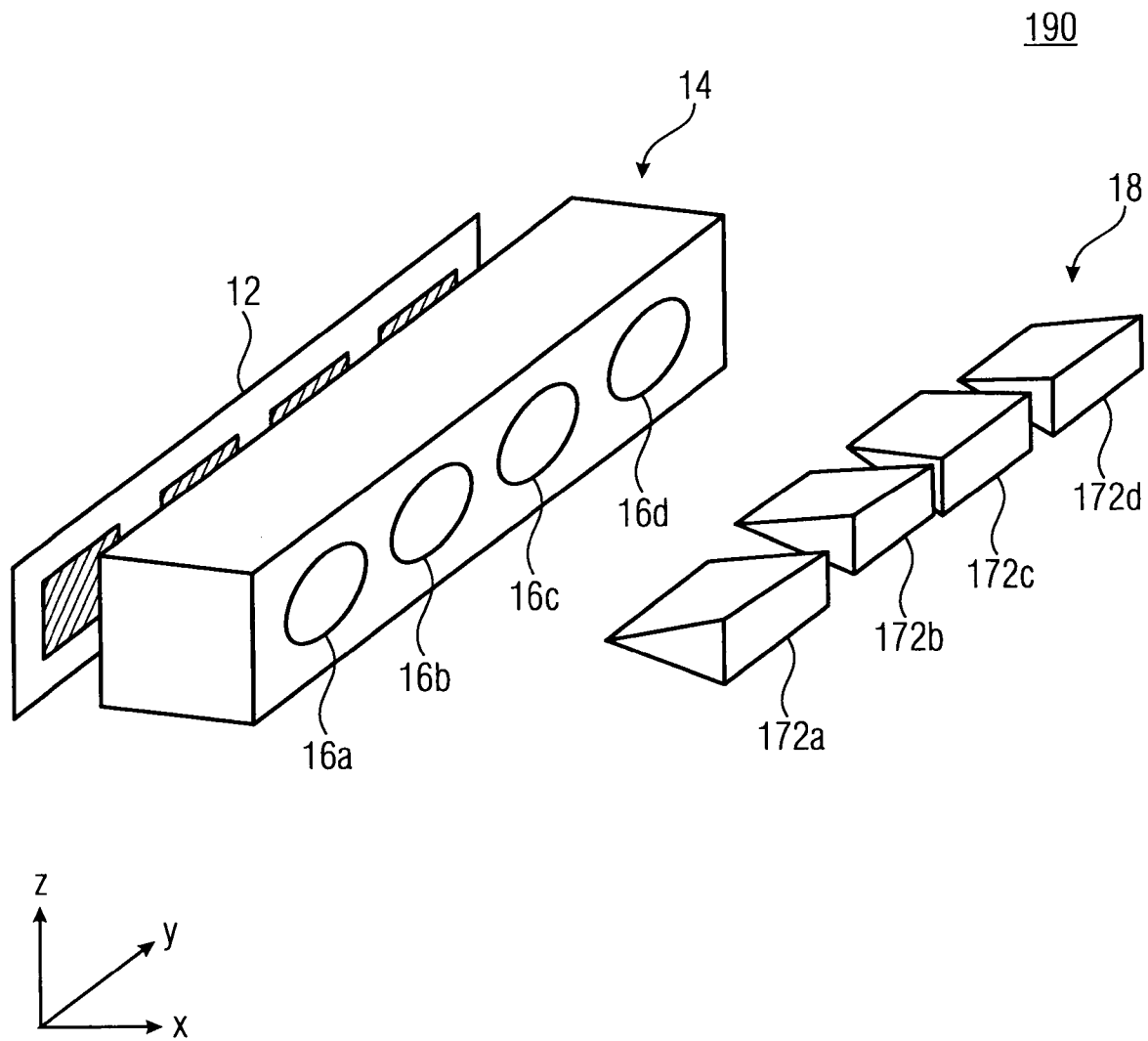

Fig. 6c

12/22

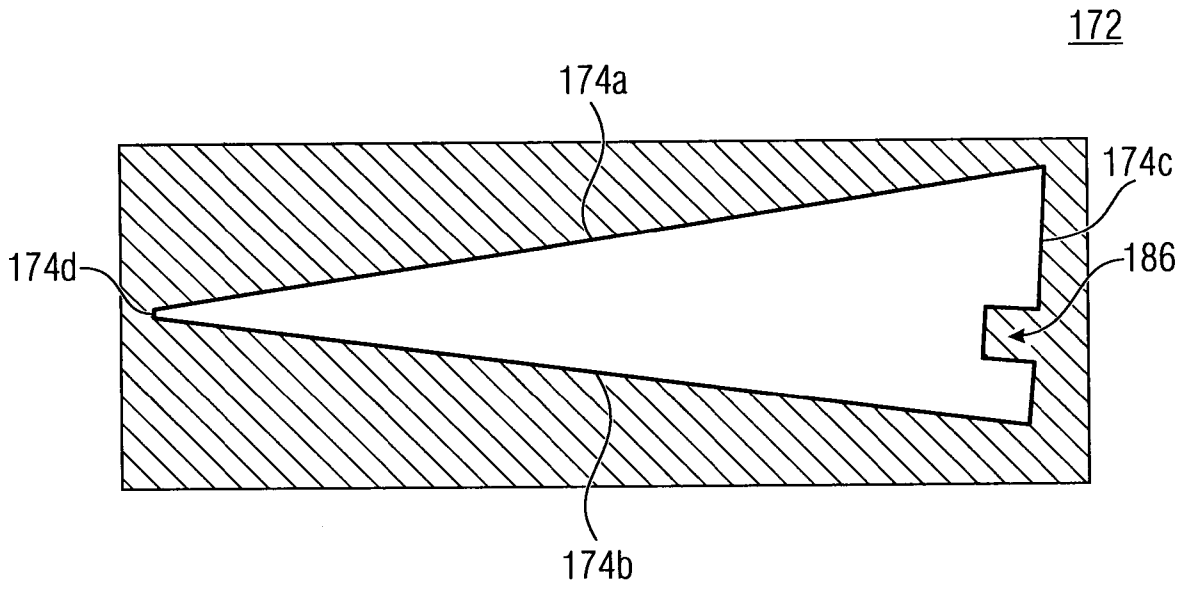

Fig. 6d

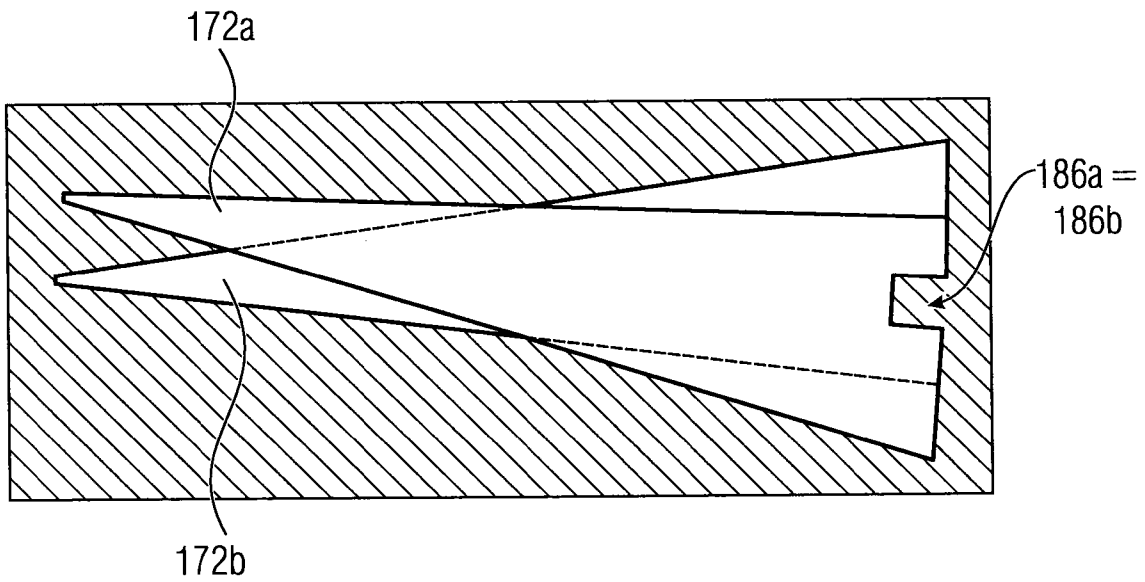

Fig. 6e

18

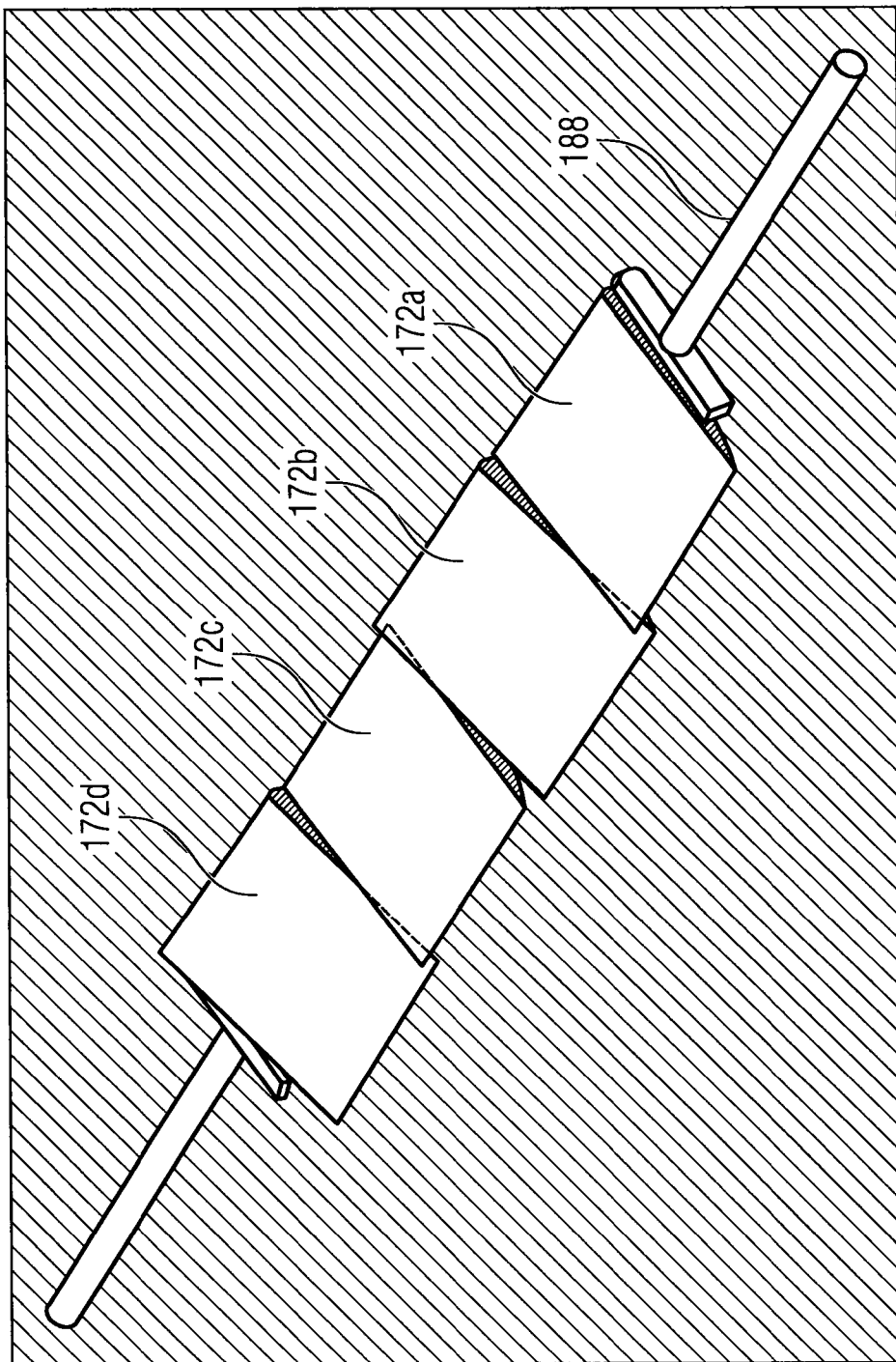

Fig. 6f

14/22

60

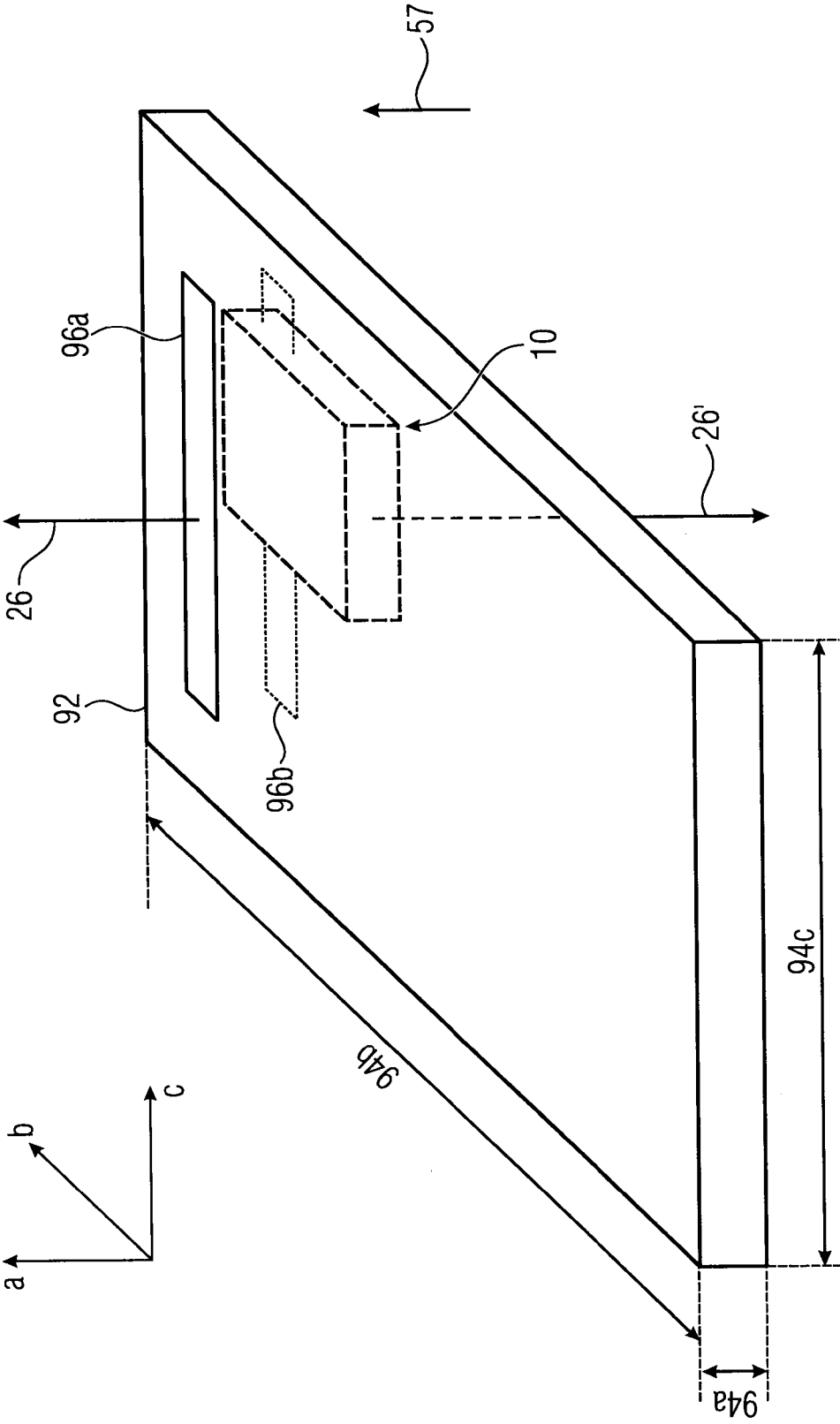

Fig. 7

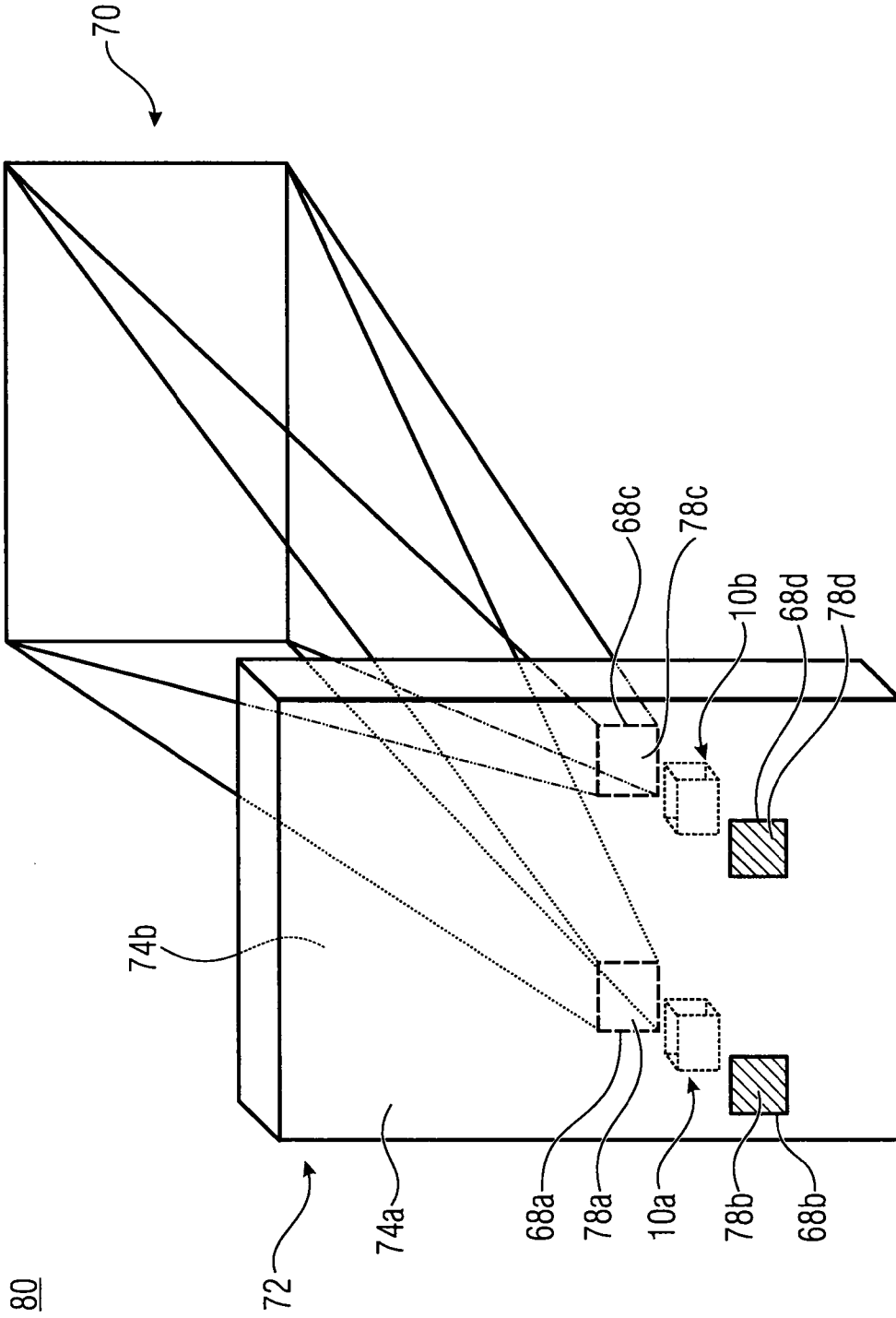

Fig. 8

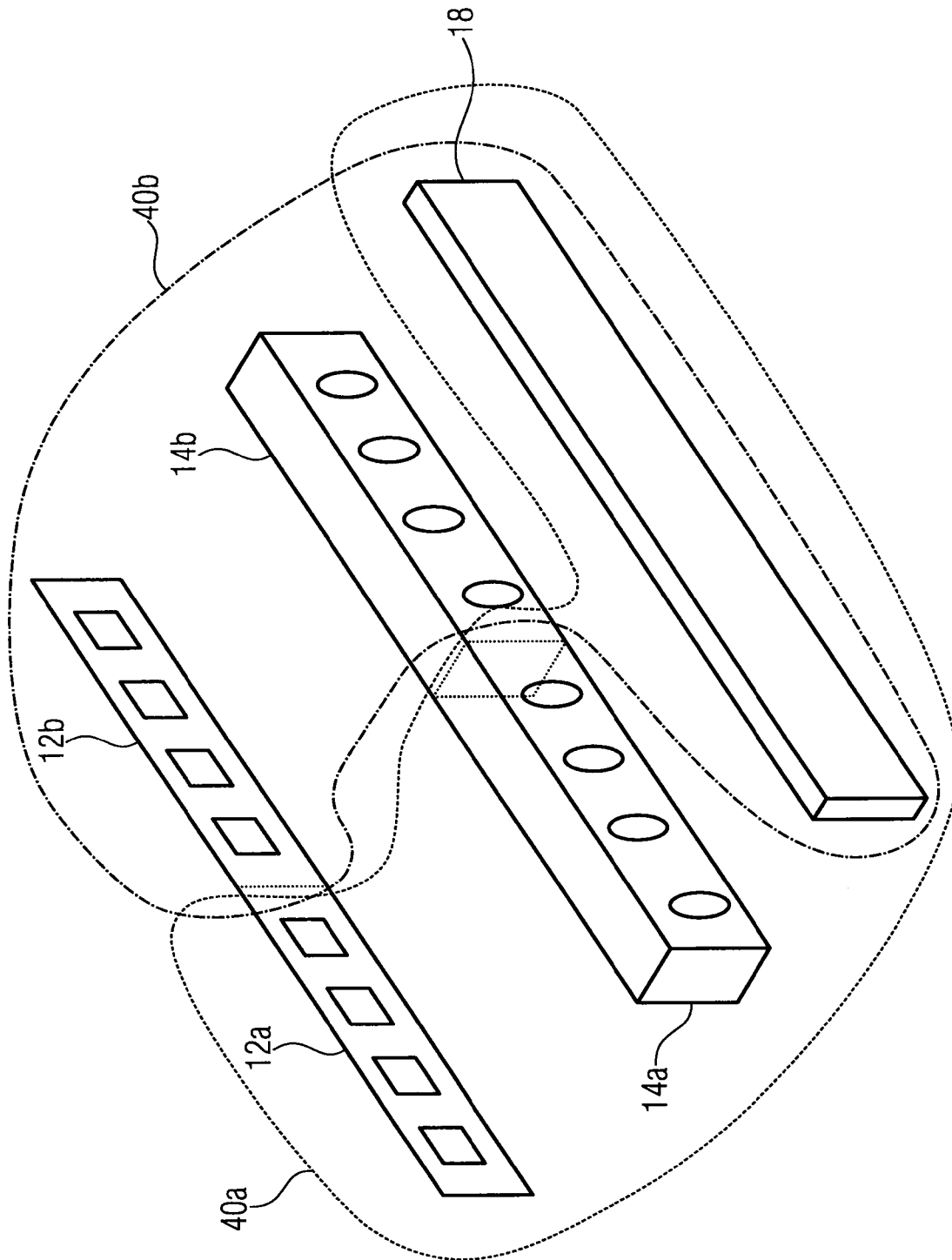

Fig. 9

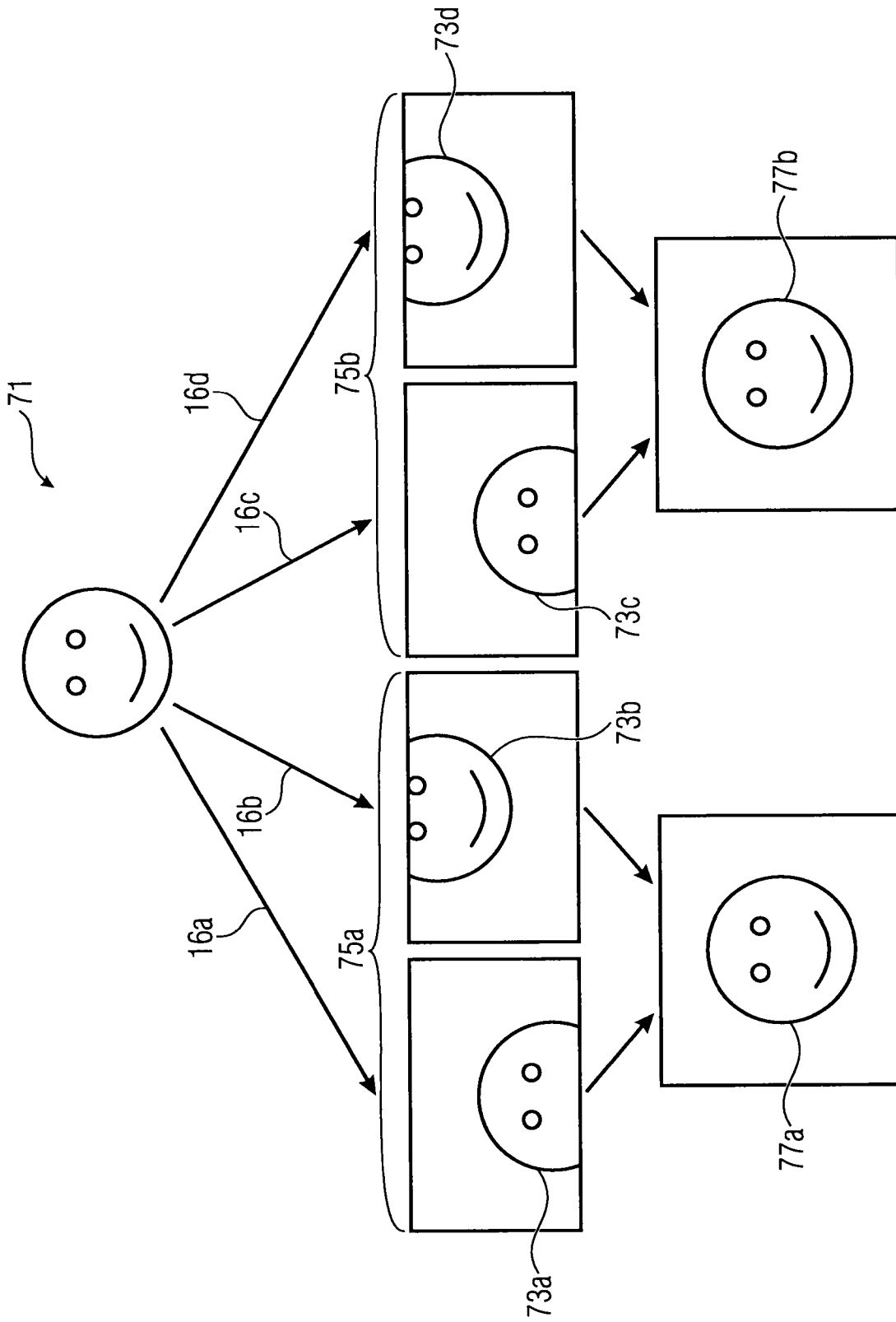

Fig. 10a

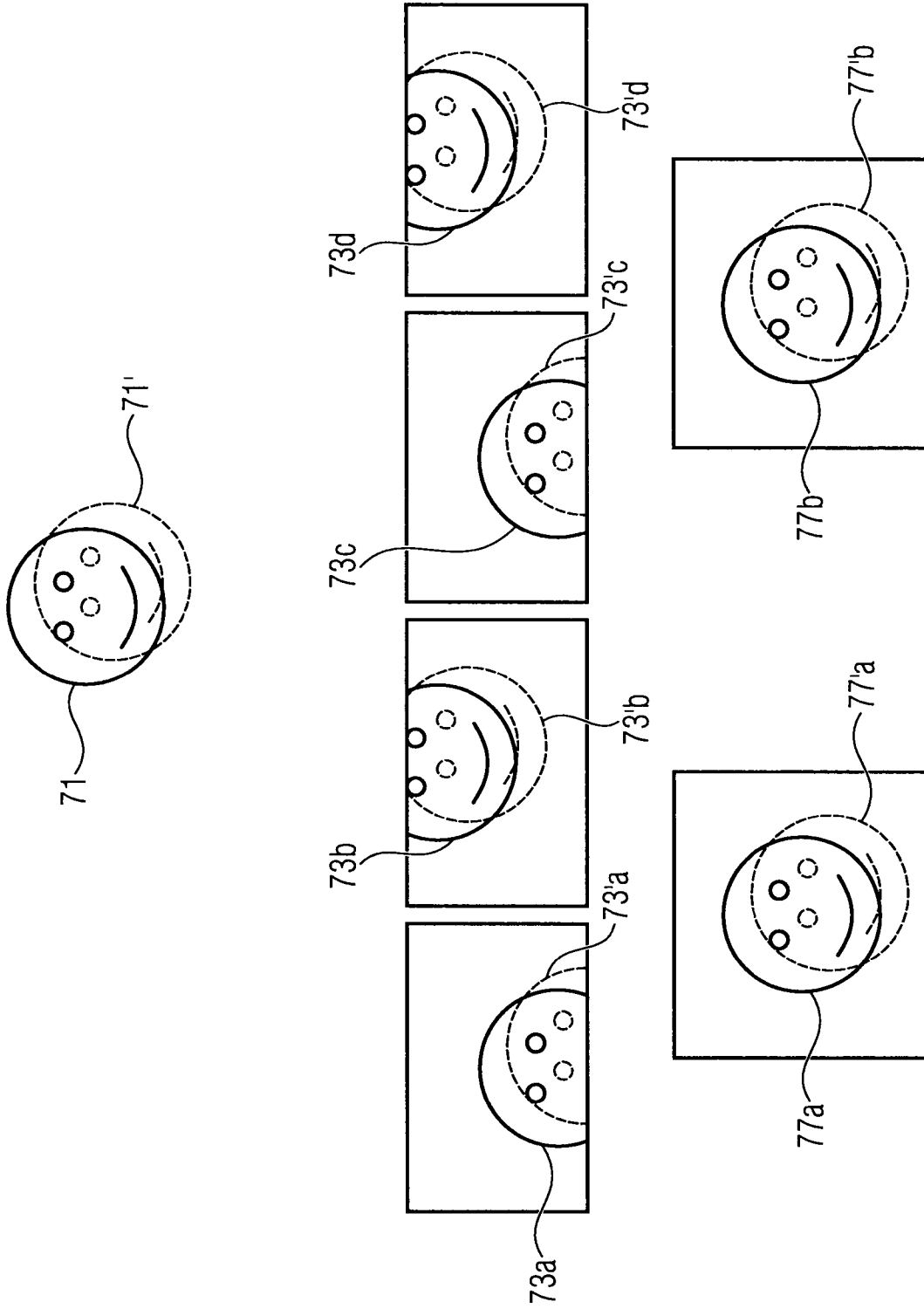

Fig. 10b

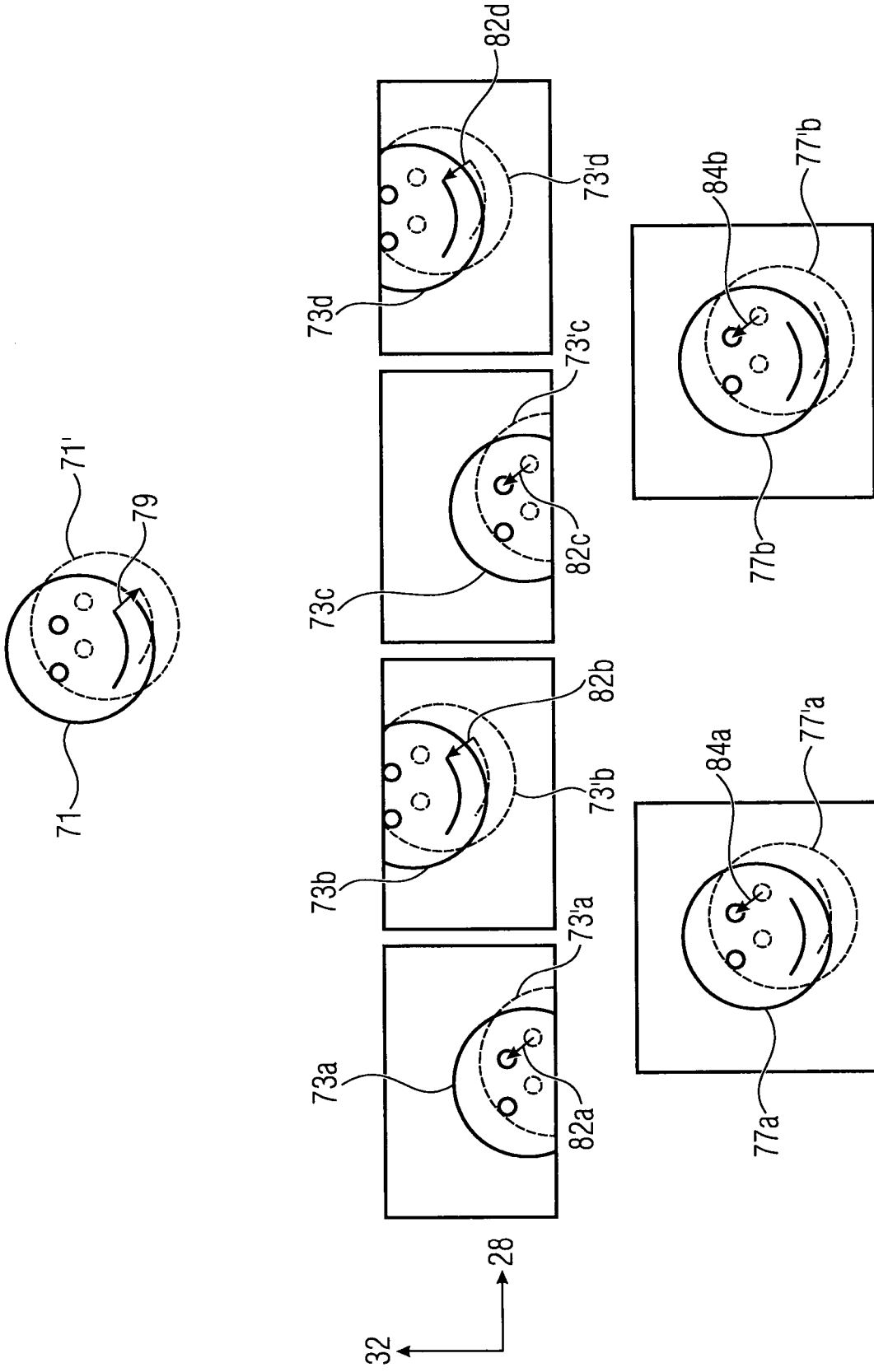

Fig. 10c

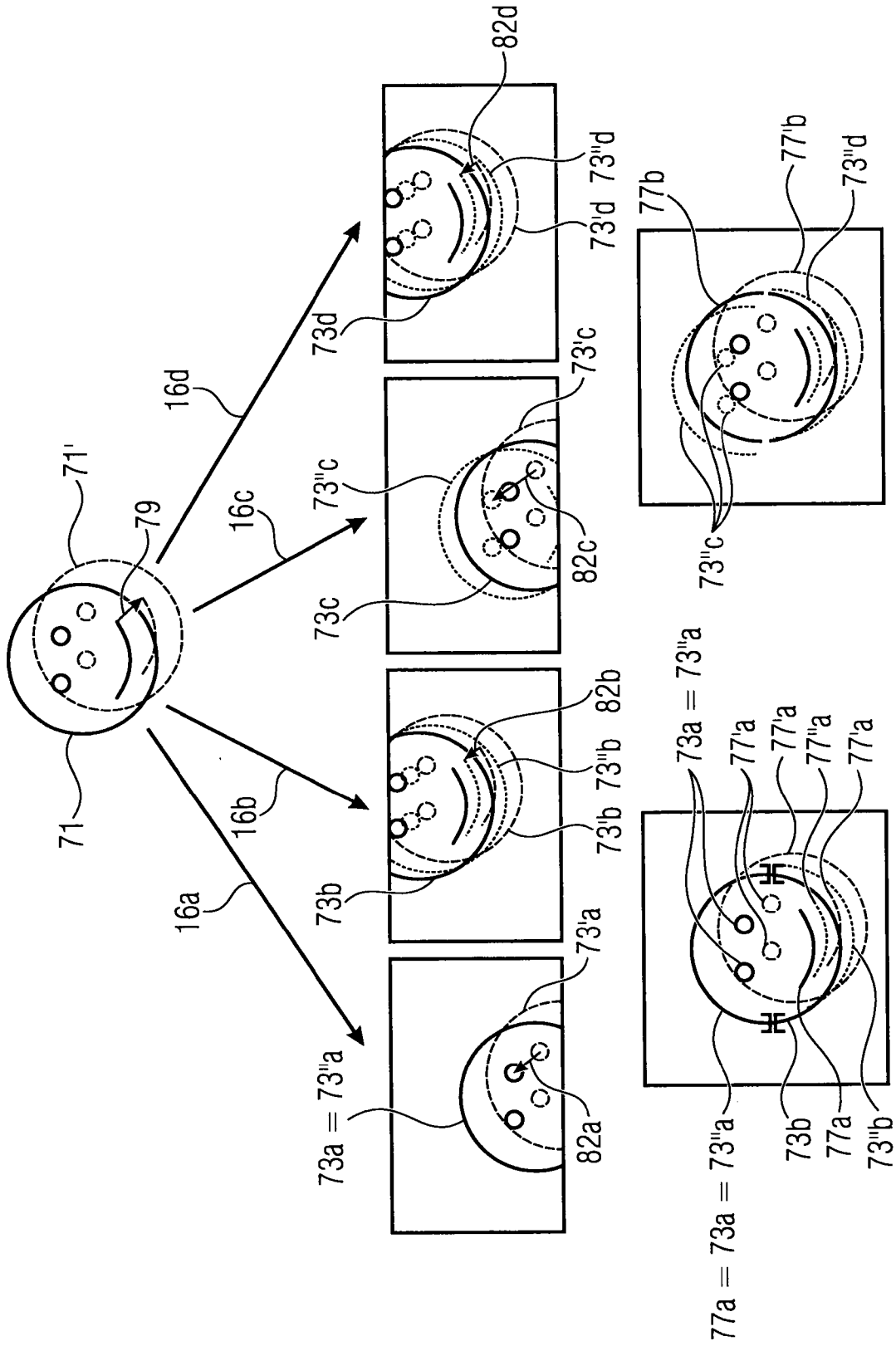

Fig. 10d

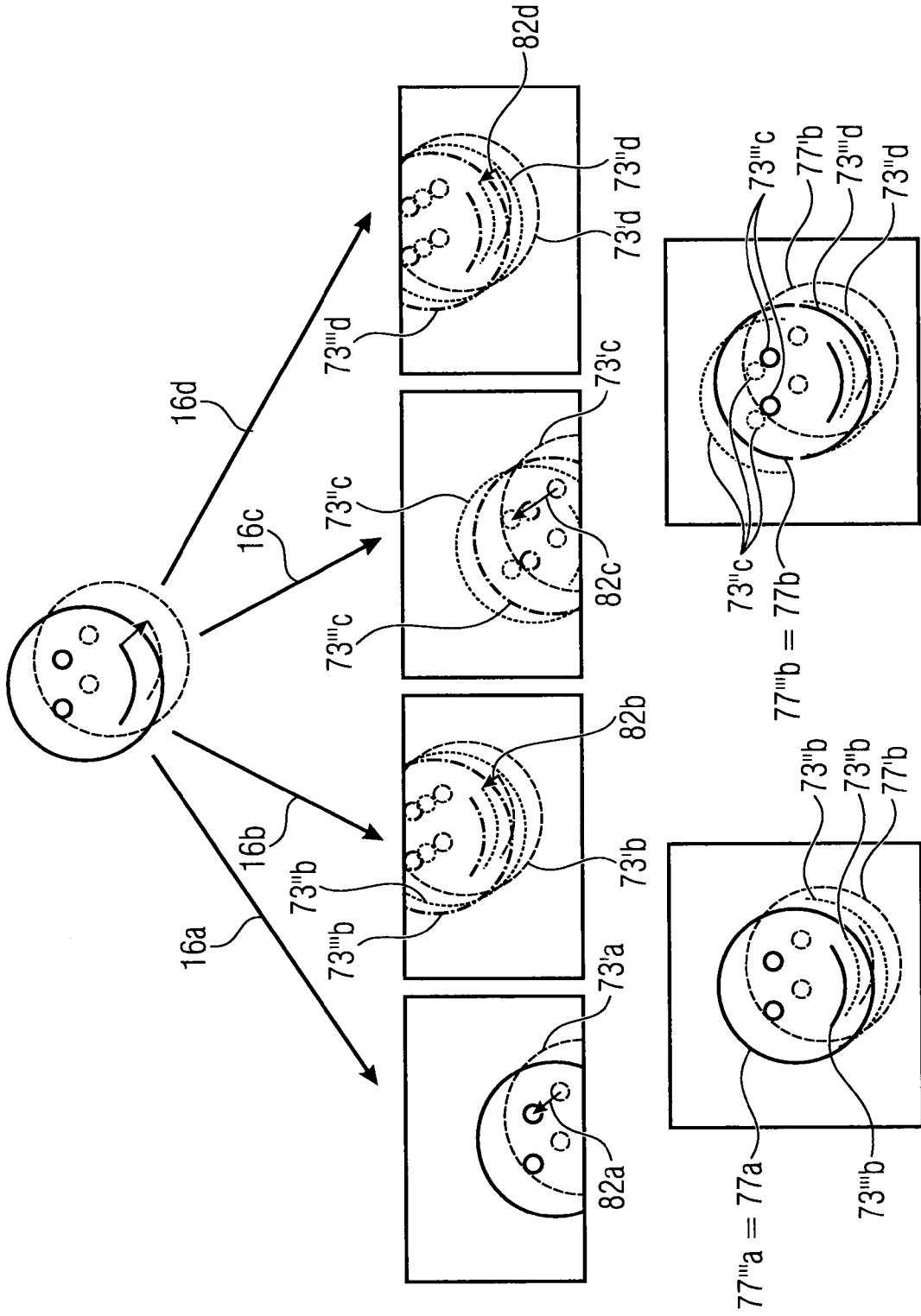

Fig. 10e

22/22

1100

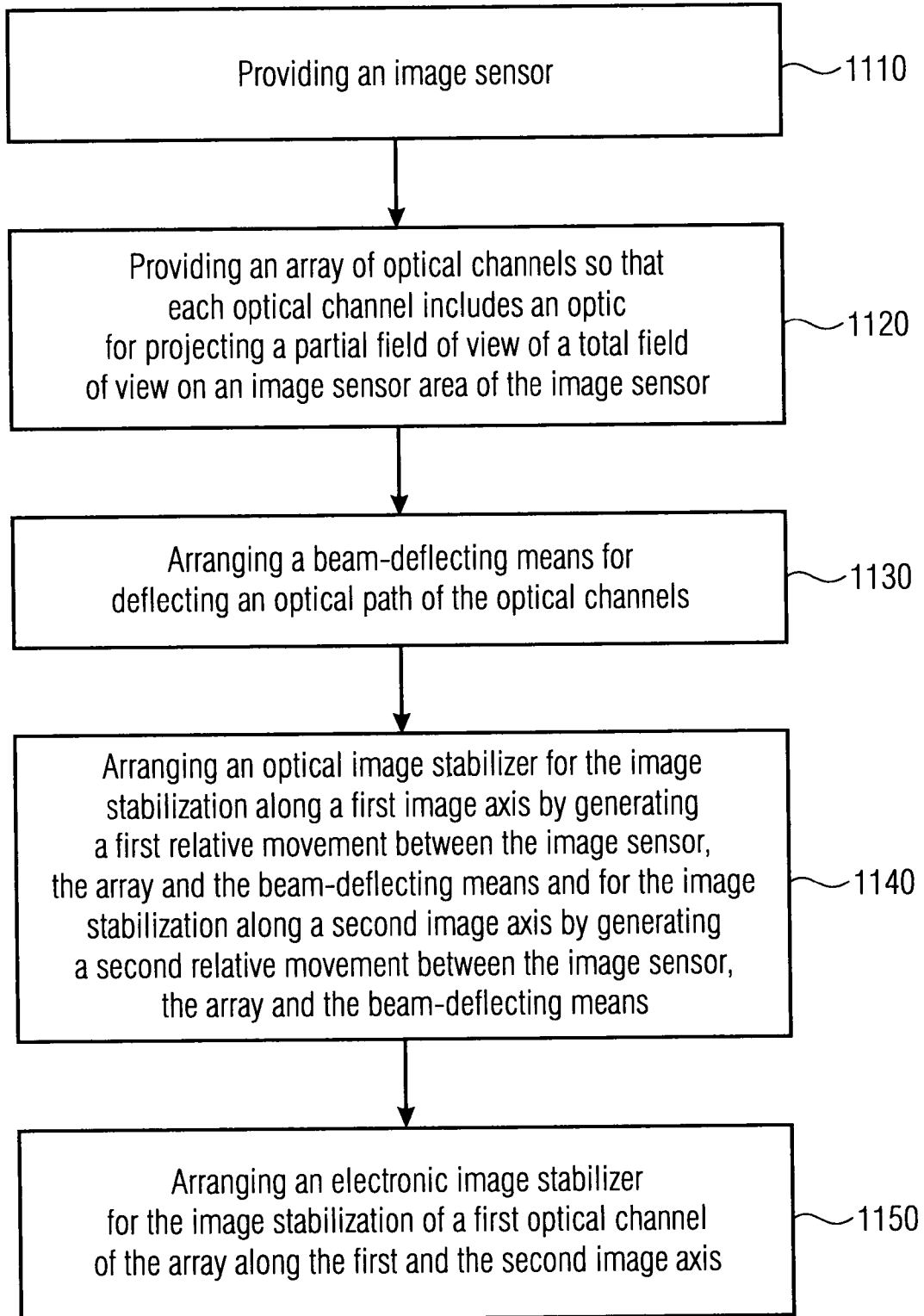

Fig. 11

