

Feb. 7, 1928.

E. R. WINSLOW

1,658,149

MOVING PICTURE MACHINE ATTACHMENT

Filed Aug. 17, 1926

2 Sheets-Sheet 2

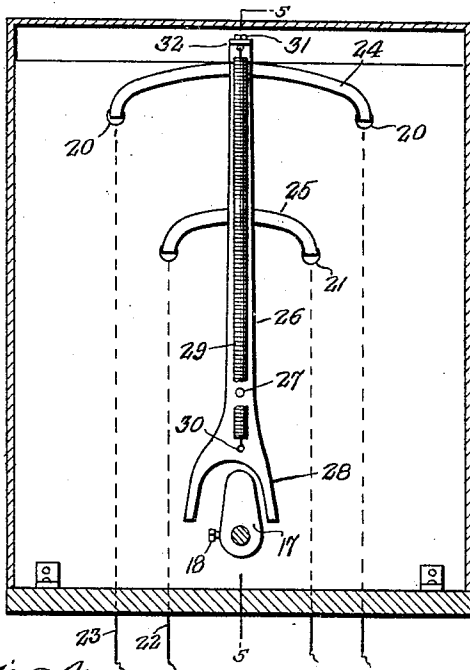

Fig. 4.

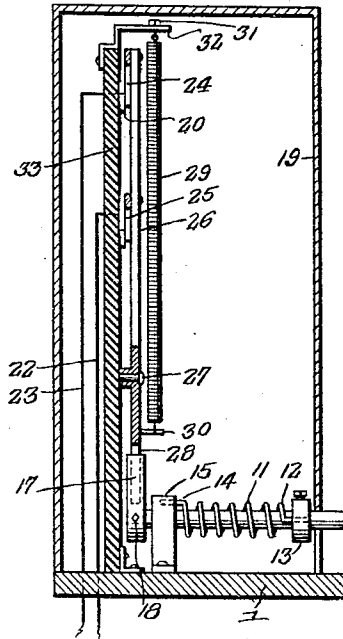

Fig. 5.

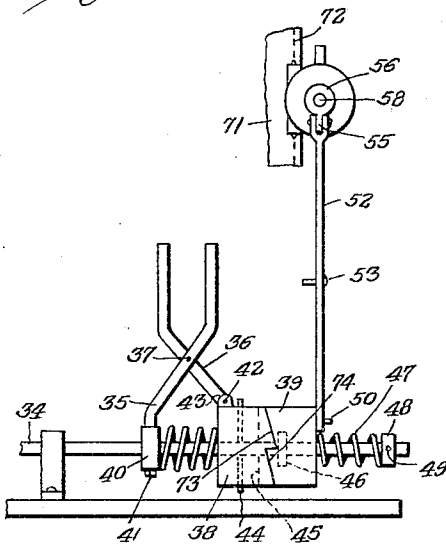

Fig. 7.

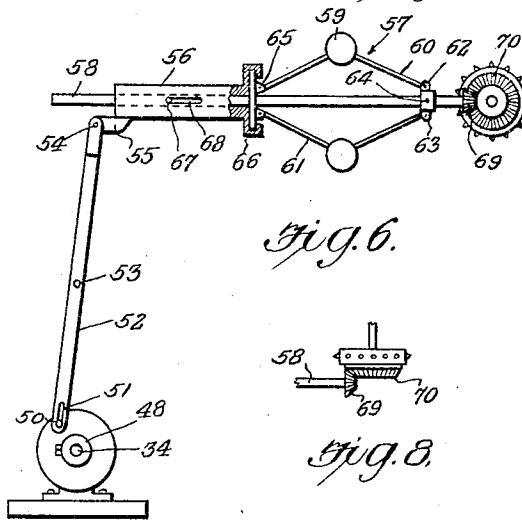

Fig. 6.

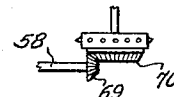

Fig. 8.

INVENTOR.
E. R. Winslow,

BY *[Signature]*
ATTORNEY.

UNITED STATES PATENT OFFICE.

ELBERT R. WINSLOW, OF GIBBON, NEBRASKA.

MOVING-PICTURE-MACHINE ATTACHMENT.

Application filed August 17, 1926. Serial No. 129,318.

The invention relates to a moving picture machine attachment.

The object of the present invention is to provide for moving picture machines a simple practical and efficient attachment of strong, durable and comparatively inexpensive construction, adapted to be readily applied to moving picture machines and capable of preventing ignition of films used in moving picture machines and fires resulting from the ignition of films.

The catching fire of films is nearly always due to the film breaking while the pictures are being projected and a part of the film stopping in the light of the lamp house. This light is very strong and will fire a film in a few seconds if the light is not shut off or the film removed. It is therefore an object of the present invention to provide a device adapted to operate automatically on the instant of breakage of a film to open the machine circuit and the light circuit and instantly stop the machine and shut off the light, and thereby effectually prevent any ignition of the film resulting from the breakage of a film while the pictures are being projected.

With these and other objects in view, the invention consists in the construction and novel combination and arrangement of parts hereinafter fully described, illustrated in the accompanying drawings and pointed out in the claims hereto appended, it being understood that various changes in the form, proportion and minor details of construction, within the scope of the claims, may be resorted to without departing from the spirit or sacrificing any of the advantages of the invention.

In the drawings:

Figure 1 is a side elevation of a moving picture machine attachment constructed in accordance with this invention.

Fig. 2 is an end elevation of the same.

Fig. 3 is a horizontal sectional view taken substantially on the line 3—3 of Fig. 1.

Fig. 4 is a vertical sectional view on the line 4—4 of Fig. 1.

Fig. 5 is a vertical sectional view taken substantially on the line 5—5 of Fig. 4.

Fig. 6 is a side elevation illustrating another form of the film controlling mechanism.

Fig. 7 is an end view of the mechanism shown in Fig. 6.

Fig. 8 is a plan view illustrating the ar-

rangement of the film actuated sprocket roller.

In the accompanying drawings, in which are illustrated the preferred embodiments of the invention, and referring particularly to Figs. 1 to 5, inclusive, of the same, the moving picture machine attachment comprises in its construction a base 1 consisting of a suitable plate adapted to be arranged on the moving picture machine and provided at the bottom with a clamp 2 for engaging the said machine. The clamp is shown provided with a clamping screw 3 arranged in spaced relation with the lower face of the base and adapted to be readily adjusted into and out of engagement with a portion of the machine. Any other form of clamp, however, may of course be employed, as will be readily understood. The base is provided with spaced bearings 4 in which is journaled a horizontal rock shaft 5 having adjustably mounted on its front end an arm 6 carrying a film engaging roller 7. The arm 6 is provided at its lower end with a sleeve 8 which is secured to the front end of the rock shaft 5 by a screw 9 or other suitable fastening device. The arm 6 is equipped at its upper end with a suitable spindle 10 extending horizontally from the arm and having mounted on it the film engaging roller 7. The roller 7 is yieldably maintained in engagement with the film by means of a coiled spring 11 disposed on the inner or rear end of the rock shaft 5 and secured at the end 12 to an adjustable collar 13 and at its other end 14 to a bearing 15 of the base 1 of the attachment. The collar 13 is adjusted by means of a set screw 16 to place the spring under the desired tension. The roller 7 is adapted to rotate to permit the film to travel over it with a minimum amount of friction, and the coiled spring is adapted in the event of the breakage of the film to cooperate with the arm 6 and cause a partial cooperation of the rock shaft 5 sufficient to oscillate a switch controlling arm 17 adjustably mounted on the inner or rear end of the rock shaft 5. The partial rotation of the rock shaft and the oscillation of the switch controlling arm 17 are adapted to operate the switch mechanism hereinafter described for cutting off the current to the machine and to the light of the lamp house, and thereby effectually preventing ignition of the film in the event of breakage of the film. The switch operating arm 17 is se-

cured to the rock shaft 5 by means of a set screw 18 for enabling the arm to be properly positioned with relation to the switch mechanism, and in practice either or both of the adjustments of the arms of the rock shaft may be employed.

The switch mechanism is arranged within a switch casing 19 suitably mounted upon the base at one end thereof and provided with the spaced contacts 20 and 21, to which extend electric wires 22 and 23. The wires 22 constitute a portion of the motor circuit for operating the machine, and the wires 23 constitute a portion of the light circuit of the lamp house, but of course the circuits may be reversed. The spaced contacts 20 and 21 constitute breaks in the machine circuit and in the light circuit, and when the machine is in operation these breaks are bridged by curved conductor bars 24 and 25, which are carried by a movable switch lever 26. The switch lever, which is pivoted at 27 by a pin or other suitable pivot, is constructed of suitable insulating material and the conductor bars are arched or curved so as to clear the contacts when the switch lever is swung by the rock shaft due to the breaking of a film. The switch lever is pivoted intermediate of its ends and the conductor bars 24 and 25 constitute arms extending laterally from the upper portion of the switch lever. The lower arm of the switch lever is forked to form a yoke 28 which provides two spaced sides and the intervening space between the sides of the yoke receives the arm 17 of the rock shaft, which is adapted to actuate the switch lever to move the conductor bars away from the contacts. In order to provide a quick throw of the switch in the operation of the same by the rock shaft, a vertical coiled spring 29 is connected at its lower end to a pin or projection 30 of the lower arm of the rock shaft and at its upper end to an eye-bolt 31 of a bracket 32 fixed to the support 33 upon which the switch lever and the contacts 20 and 21 are mounted. The support is constructed of suitable insulating material and the bracket 32 is arranged at the top thereof and projects therefrom in alignment with the pivot 27, so that the spring will maintain its position when the lever is on a dead center. As the lower end of the spring is connected with a lever below the pivot 27 any movement of the lever from its vertical position will carry the lower portion of the spring to one side of the dead center and the spring will act to produce a continued movement and quick throw of the lever so that the switch will be positively operated to open the machine and lamp circuits and instantly shut off the light and the current to the motor of the machine so that there will be no liability of a broken film igniting by being exposed to the light of the lamp house. When the cur-

rent is cut off from the machine and the light of the lamp house by reason of the breakage of a film, the manually operable switches with which the machine is equipped for controlling the motor and the light are opened and the switch mechanism of the present attachment may then be reset and the film fixed before the current is turned on by the manually operable switches. The device will then be in condition for automatic operation in the event of another breakage of the film. In the form of the invention illustrated in Figs. 1 to 5 inclusive the arm extends upwardly at one side of the film and in order to enable the attachment to be applied to moving picture machines where the arrangement of the arm as shown in Fig. 2 might not be convenient, the form of the invention illustrated in Figs. 6, 7 and 8 is provided.

In the form of the invention illustrated in Figs. 6, 7 and 8, the rock shaft 34 is similar to the rock shaft 5 and extends to the switch casing 19 and is provided with the switch operating arm heretofore disclosed, and as this construction is clearly illustrated in Figs. 1 to 5 inclusive of the drawings it is omitted from Figs. 6, 7 and 8 to avoid duplicating the illustrations of the switch mechanism. The rock shaft 34 is equipped at its front end with a laterally swinging arm composed of the crossed levers 35 and 36 which are pivoted at 37, the outer arms of the levers 35 and 36 being spaced and forming spaced handles which are adapted to be grasped by the operator for withdrawing a slidable clutch section 38 out of engagement with a clutch section 39. The lever 35 is secured at its inner or lower end to a collar 40 which is adjustably mounted on the shaft 34 by a set screw 41 and the lever 36 is secured at the lower end by a pivot 42 to a lug or ear 43 of the slidable clutch section 38. A spring is interposed between the collar 40 and the slidable clutch section normally in engagement with the clutch section 39. The collar 40 is adapted to be adjusted to control the tension of the spring. The slidable clutch section is connected with the shaft 34 by a pin or key 44 which pierces the shaft and operates in a longitudinal slot 45 of the slidable clutch section 38. The shaft 34 is provided with a fixed collar 46 which is engaged by the clutch section 39, a coiled spring 47 being interposed between the clutch section 39 and an adjustable collar 48 secured to the shaft 34 by a set screw 49. The clutch section 39 is loose on the shaft and is maintained in engagement with the collar 46 by the spring 47, the collar 46 limiting the movement of the clutch section 39. The clutch sections are in the form of sleeves and the clutch section 39, which is cylindrical, is provided with an eccentric pin 50 operating in the slot 51 of a lever 52 pivoted

intermediate of its ends at 53 to provide opposite arms, one arm being connected with the clutch section 39 and the other arm being connected by a pivot 54 to an ear or lug 55 of a slidable sleeve 56 of a film controlled governor 57. The governor 57, which is of ordinary construction, is mounted on a horizontal shaft 58 and it consists of opposite weights 59 and springs 60 and 61. The springs 60 and 61 are secured at one end at 62 to a collar 63 adjustably fixed to the shaft 58 by a set screw 64. The other ends of the springs are secured at 65 to the head 66 of the slidable sleeve 56. The weights 59 are suitably secured to the springs 60 and 61 intermediate of the ends thereof and the said weights are thrown outward by centrifugal force when the shaft 58 is rotated. Various other forms of governors may of course be used. The sleeve 56 is slidably mounted on the shaft 58 by means of a pin 67 piercing the shaft 58 and operating in a slot 68 of the sleeve.

The shaft 58 is provided at its front end with a pinion 69 which meshes with a gear 70 of a sprocket roller 71 provided at its ends with sprocket teeth 72 which are adapted to engage the apertures at opposite sides of the film. When the film is in motion the sprocket roller 71 will be rotated and rotary motion will be communicated to the shaft by the gears 69 and 70 and the governor will assume the position illustrated in Fig. 6 of the drawings, with the weights thrown outward through centrifugal force. Should the film break, the shaft 58 will rapidly reduce in speed and the weights will move inwardly through the action of the springs which are parted and distended from their normal position by the operation of the weights under the action of centrifugal force. This inward movement of the springs of the weights will slide the sleeve 56 longitudinally of the shaft 58 and will oscillate the lever and partially rotate the cylindrical section of the governor. In practice the clutch and the switch will be set when the governor is at rest and the outward movement of the weights will partially rotate the section 39 of the clutch, which will ratchet over the clutch section 38. The clutch sections are provided at their engaging faces with ratchet teeth 73 and 74 and the teeth are arranged as shown in Fig. 7 to permit this operation. When, however, the weights move inwardly the ratchet teeth will interlock and the shaft 34 will be rocked and the switch operated to move the conductor bars away from the contacts 20 and 21 and thereby open the machine and light circuits in the manner heretofore described.

What I claim is:

1. A moving picture machine attachment

comprising means for mounting the attachment on a moving picture machine, a switch mechanism having spaced contacts arranged in pairs at different elevations and forming breaks in the circuits of the machine and light of the lamp house, said switch being provided with a laterally movable switch member normally arranged on a dead center and adapted to move to one side of the same and having laterally projecting conductor bars arranged to bridge the contacts and close the said circuits, and film controlled mechanism for actuating the movable switch member when the film breaks.

2. A moving picture machine attachment comprising means for mounting the attachment on a moving picture machine, a switch mechanism having spaced contacts arranged in pairs at different elevations and forming breaks in the circuits of the machine and light of the lamp house, said switch having a pivoted switch lever normally arranged in an upright position on the dead center and provided with laterally projecting conductors arranged to bridge the said contacts, film controlled mechanism including a rock shaft movable when the film breaks and having an arm arranged to actuate the switch lever to move the same off the dead center for opening the switch, and means connected with the lever and normally inactive to actuate the same and arranged to be carried into position for actuating the lever when the latter is moved off dead center.

3. A moving picture machine attachment comprising means for mounting the attachment on a moving picture machine, a switch mechanism having spaced contacts arranged in pairs at different elevations and forming breaks in the circuits of the machine and light of the lamp house, said switch having a pivoted switch lever normally arranged in an upright position on a dead center and provided with laterally projecting conductors arranged to bridge the said contacts, said switch lever being also provided with a forked arm, and film controlled mechanism including a rock shaft movable when the film breaks and provided with an arm operating in the forked arm of the switch lever and adapted to actuate the switch lever to move the same off dead center to open the switch.

4. A moving picture machine attachment comprising means for mounting the attachment on a moving picture machine, a switch mechanism having spaced contacts arranged in pairs at different elevations and forming breaks in the circuits of the machine and light of the lamp house, said switch having a pivoted switch lever normally arranged in an upright position on the dead center provided with laterally projecting conductors arranged to bridge the said contacts, a spring extending longitudinally of the switch le-

ver and connected therewith and mounted centrally with respect to the same, said spring being normally arranged on a dead center inactive to move the lever in either direction and adapted to be carried over the dead center by a movement of the switch lever to an active position to provide a quick action of the switch, and film controlled mechanism including a rock shaft movable when the film breaks and provided with means for oscillating the switch lever.

5. A moving picture machine attachment comprising means for mounting the attachment on a moving picture machine, a switch mechanism having spaced contacts arranged in pairs and forming breaks in the circuits of the machine and light of the lamp house, said switch mechanism being provided with a switch lever normally arranged on a dead center and having conductors arranged to bridge the contacts, and film controlled mechanism including a rock shaft having an arm arranged to actuate the switch lever to move the latter off dead center and an arm connected with the rock shaft and normally maintained in an upright position and arranged to swing downward when the film breaks.

6. A moving picture machine attachment comprising means for mounting the attachment on a moving picture machine, a switch mechanism having spaced contacts arranged in pairs and forming breaks in the circuits of the machine and light of the lamp house, said switch mechanism being provided with a switch lever normally arranged on a dead center having conductors arranged to bridge the contacts, and film controlled mechanism including a rock shaft having an arm arranged to actuate the switch lever to move the latter off dead center and an arm connected with the rock shaft and provided with a roller arranged to bear against the film whereby the arm is normally supported in an upright position and is caused to fall when the film breaks.

7. A moving picture machine attachment comprising film controlled mechanism including a rock shaft having an arm normally maintained in an upright position by the film, switch mechanism having spaced contacts adapted to be included in the circuits of the machine and the lamp thereof, said switch being provided with a movable switch lever normally arranged on a dead center and having conductors arranged to

bridge the said contacts, and means carried by the rock shaft for operating the switch lever to move the same off dead center.

8. A moving picture machine attachment comprising film controlled mechanism including a rock shaft having an arm normally maintained in an upright position by the film, switch mechanism having spaced contacts adapted to be included in the circuits of the machine and the lamp thereof, said switch being provided with a movable switch lever normally arranged on a dead center and having conductors arranged to bridge the said contacts, means carried by the rock shaft for operating the switch lever to move the latter off dead center, and an adjustable spring connected with the rock shaft and cooperating with the arm for rotating the rock shaft, said spring being adjustable to reduce the pressure of the arm against the film.

9. A motion picture attachment comprising means for mounting the attachment on a picture machine, a switch mechanism having spaced contacts arranged in pairs at different elevations and at different distances apart and forming breaks in the circuit of the machine and the light of the lamp house, said switch mechanism having a pivoted switch lever normally arranged in an upright position on a dead center between the spaced contacts and provided with laterally extending conductor bars of different lengths arranged to bridge the said contacts, the pivot of the lever being located intermediate of the ends thereof and the lower end of the lever being provided with a depending fork, an upright spring extending longitudinally of the lever and connected therewith and normally arranged in an inactive position on a dead center and arranged to actuate the lever when moved off dead center, and film controlled mechanism including a rock shaft provided at one end with an arm extending into the fork of the lever and adapted to move the latter off dead center, a film engaging arm mounted on the rock shaft and an adjustable coiled spring disposed on the rock shaft and connected therewith to vary the pressure of the arm on the film and adapted to reduce the pressure and friction on the film.

In testimony whereof I have hereunto set my hand.

ELBERT R. WINSLOW.