

J. Du BOIS. Machine for Ripping, Surfacing, and Matching Lumber.

No. 200,992.

Patented March 5, 1878.

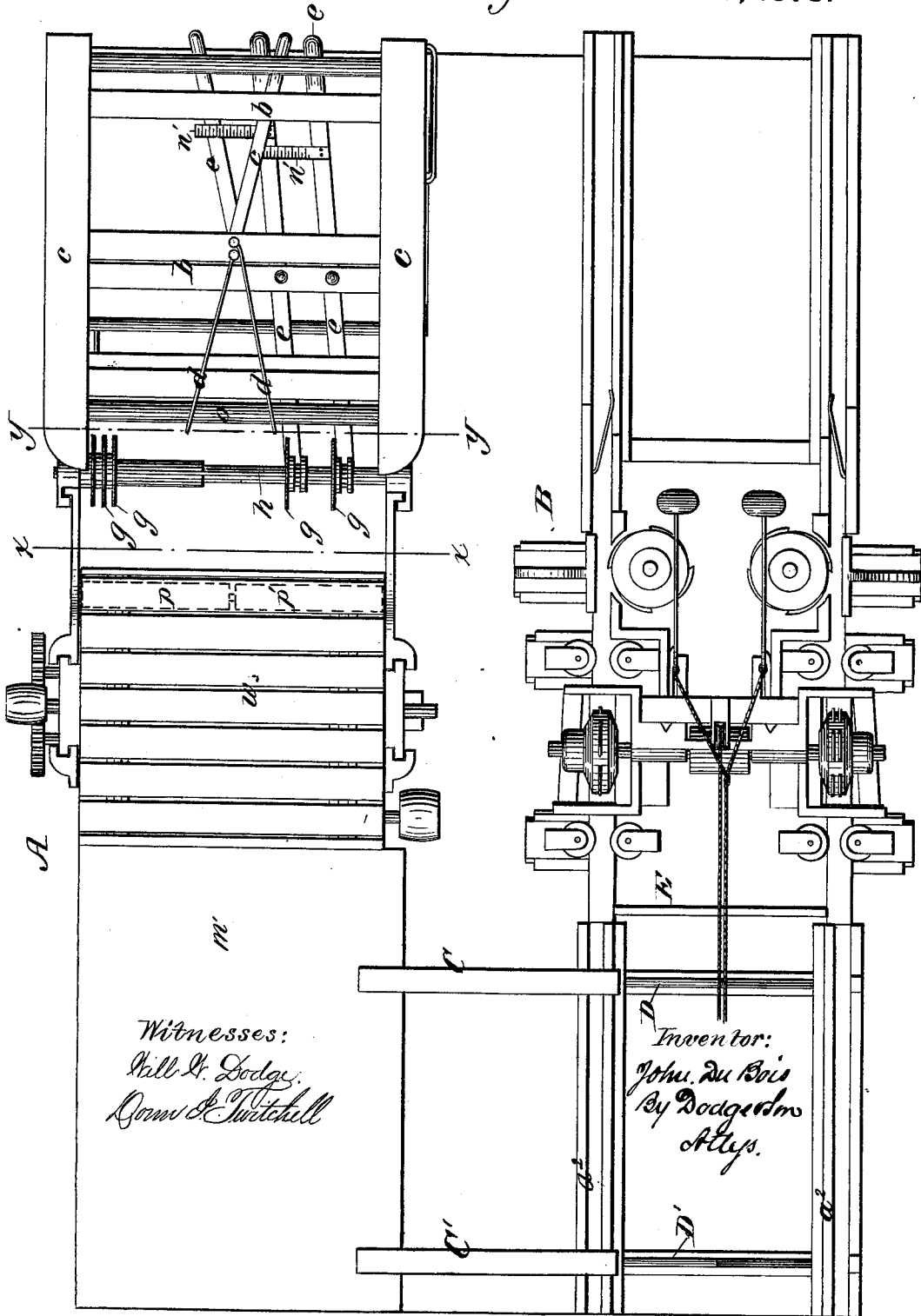

Witnesses:
 Will H. Dodge,
 Rowland T. Mitchell

Inventor:
 John Du Bois
 By Dodger & Co
 Atty.

J. Du BOIS. Machine for Ripping, Surfacing, and Matching Lumber.

No. 200,992

Patented March 5, 1878.

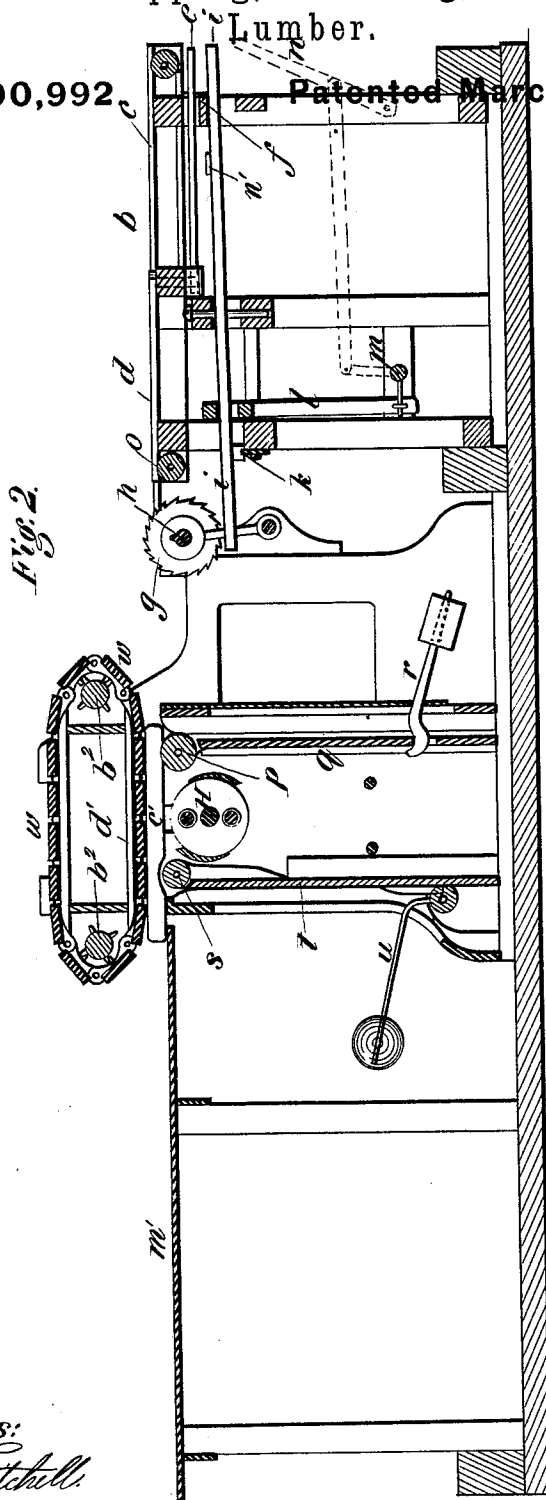

Fig. 2.

Witnesses:
John P. Twitchell.
Will H. Dodge.

Inventor:
John Du Bois
By Dodge & Sm.
Attys.

J. Du BOIS.
Machine for Ripping, Surfacing, and Matching
Lumber.

No. 200,992.

Patented March 5, 1878.

Fig. 3.

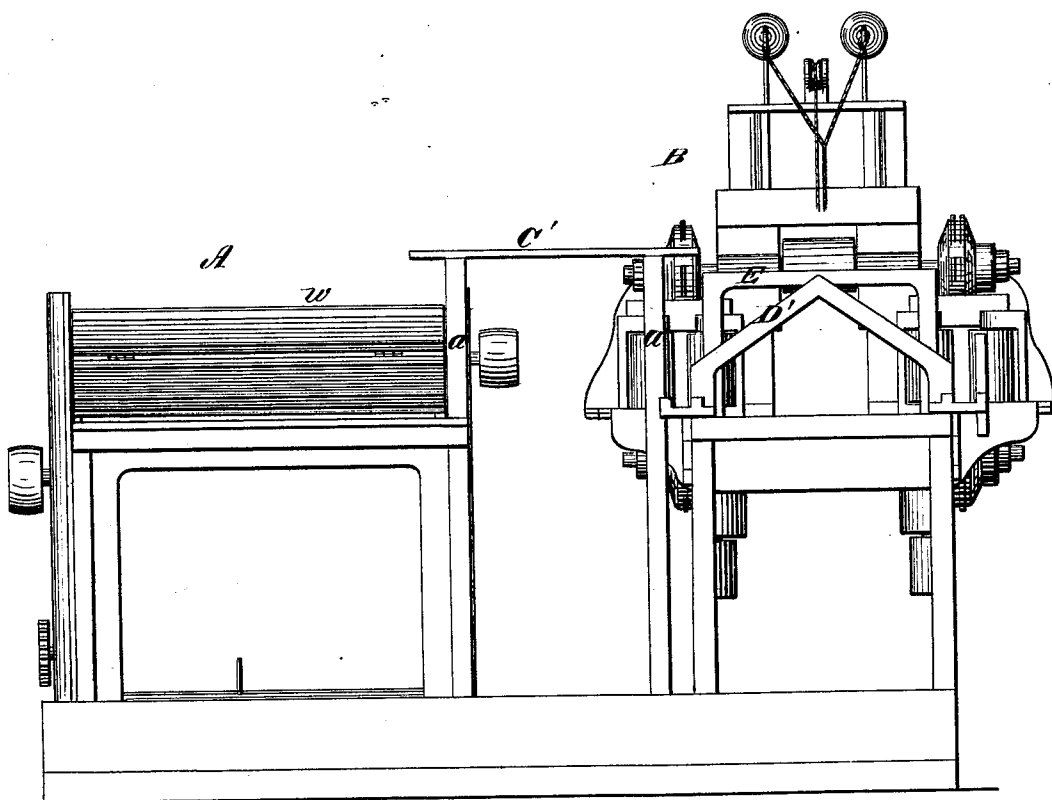

Witnesses:
Samuel P. Twitchell
Hill H. Dodge.

Inventor:
John Du Bois.
By Dodge & Son
Attys.

J. Du BOIS.
Machine for Ripping, Surfacing, and Matching
Lumber.

No. 200,992.

Patented March 5, 1878.

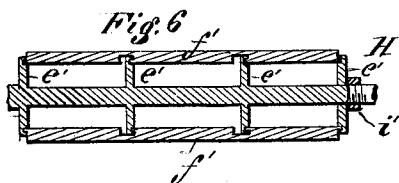
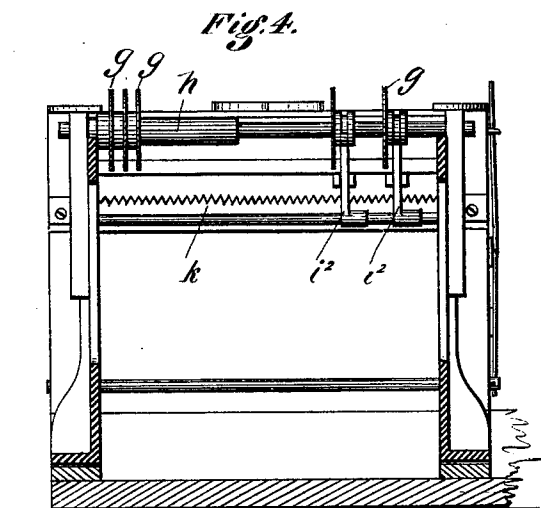
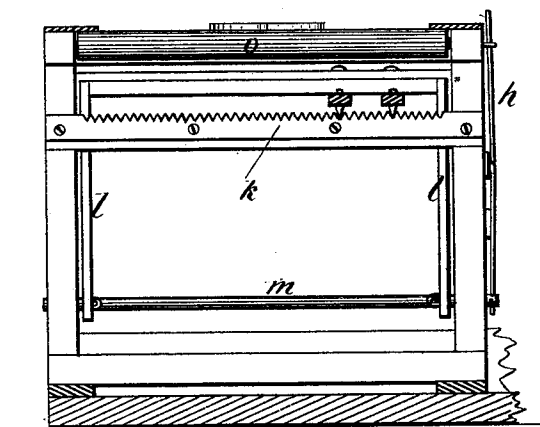
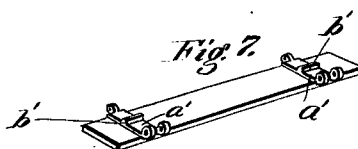

Fig. 5.



Witnesses:

Sam J. Twitchell.
Will H. Dodge

Inventor:

John Du Bois
By Dodge & Co.
Atlys.

UNITED STATES PATENT OFFICE.

JOHN DU BOIS, OF WILLIAMSPORT, PENNSYLVANIA.

IMPROVEMENT IN MACHINES FOR RIPPING, SURFACING, AND MATCHING LUMBER.

Specification forming part of Letters Patent No. **200,992**, dated March 5, 1878; application filed April 12, 1877.

To all whom it may concern:

Be it known that I, JOHN DU BOIS, of Williamsport, in the county of Lycoming and State of Pennsylvania, have invented certain Improvements in Machinery for Ripping, Surfacing, and Matching Lumber, of which the following is a specification:

My invention relates to improvements in the construction and arrangement of machinery designed for the production of flooring and wainscoting material, molding, and other similar narrow strips which require to be matched and surfaced or otherwise worked on three or four faces; and the invention has for its object to avoid the necessity for a great portion of the manual labor now required, and to increase the production of the material.

Hitherto in the manufacture of the class of materials mentioned it has been customary to rip the wide rough boards by means of a circular saw into strips of the required width, one strip being produced at a time, and to pass these strips subsequently through a machine in which they were surfaced and tongued and grooved one at a time. This method of operation required the labor of two men to rip and lay down the strips, and a third to pass them through the surfacing and matching machine. The ripping-saw could produce the strips more rapidly than the matcher and surfer could dispose of them, and hence the material accumulated and required extra handling, and the ripping-saw required to stand idle a portion of the time, or else the labor of a fourth man and the employment of a second surfacing-machine were required to dispose of the strips.

Now, my invention is designed to dispense with a large portion of the manual labor, to avoid the extra handling of the strips, and to increase the production, while decreasing the number of operatives; and to this end the invention consists in the employment of a machine adapted to produce and surface a number of strips at once, in connection with a duplex matching-machine and intermediate supports, arranged in such relation thereto that a single attendant may feed the strips, two at a time, from the first machine to the second, by which latter they are disposed of with great

rapidity, and as fast as they are produced and surfaced by the first machine.

The invention also consists in the construction and arrangement of intermediate supports and inclined guides to assist the attendant in feeding the matching-machine; in various features of novelty in the ripping and surfacing machine, whereby it is adapted for surfacing two boards of different thicknesses at the same time, and for producing strips of any given width at will; and in minor details, which will be hereinafter fully described.

Figure 1 is a top-plan view of my complete apparatus; Fig. 2, a longitudinal vertical section through the ripping and surfacing machine; Fig. 3, an end elevation of the complete apparatus, showing the devices by which the feeding of the strips from the first to the second machine is effected; Fig. 4, a cross-section of the surfacer and ripper on the line *xx*; Fig. 5, a similar section on the line *yy*; Fig. 6, a longitudinal central section of the surfacing head or cutter; Fig. 7, a perspective view of one of the bars or slats of the endless pressure-bed of the surfacer.

A represents the machine by which the rough boards are divided into strips and the latter surfaced or planed, the machine being provided with a series of laterally-adjustable saws to divide the wide material into strips of the required width, and with a single long surfacing or planing head and two short independent presser-rolls, whereby the machine is adapted for splitting and surfacing two boards of different thicknesses at the same time. B represents a duplex matching-machine, forming the subject of a separate application bearing even date herewith, provided on opposite sides with two pairs of cutter-heads by which two boards or strips have their edges tongued and grooved at the same time independently of each other. The saws of the first machine and the cutters of the matching-machine are capable of adjustment to certain fixed and definite points to correspond with each other, so that the strips produced will be of the standard widths known and required in the market.

The matching-machine B is arranged at the side of and parallel with the ripping and surfacing machine, with its front or receiving end

of the matching-machine adjacent to the rear or delivery end of the ripping-machine, as shown, so that as the surfaced strips are delivered from the first machine, the attendant, standing at its rear end, can take them two at a time, one in each hand, and, swinging their ends over, pass them through the matching-machine.

The passage of the strips from one machine to the other may be accomplished by resting the strips on the end of the first machine as a fulcrum, and bearing down on their outer ends, and the same time swinging them around at the inner ends to the second machine; but instead of the above it is preferred to arrange between the two machines, on uprights *a*, two cross-bars or rests, *C C'*, upon which to rest the surfaced strips as they are delivered from the first machine, and to mount on the second machine, near the cutter-heads, a horizontal rest, *E*, and in front of the latter, at a suitable distance apart, two supports or guides, *D D'*, inclining from the center downward toward each side of the machine. When the parts are thus arranged the attendant places the strips as they are delivered from the first machine upon the supports *C C'*, and then, holding a strip at its end in each hand, he swings their forward ends, the ends nearest the cutters of the matching-heads, over upon the rest *E*, and then, still holding the rear ends of both strips in his hands, he swings them over in line with the front ends. At this point it will be seen the two strips extend lengthwise of the matching-machine parallel with each other, with their forward ends resting on the support *E*, and their rear ends sustained by the hands of the attendant, who immediately draws them back off from the support *E* and releases them, so that they fall upon opposite sides of the inclined supports *D*, down which they slide to opposite sides of the machine, in line with the two pairs of matching-heads, into which they are pushed.

The peculiar construction and arrangement of supports described above are considered the best for ordinary use; but it is manifest that they may be modified in form and arrangement, provided they are adapted to sustain the strips and facilitate the operation of feeding them from the first to the second machine in the manner described. For example, the rests *D D'*, or either of them, may be flattened at the middle, so that the strips will remain thereon until moved outward onto the inclined sides or ends. By thus flattening the rest *D'* it may be made to serve, in addition to its primary function, that of the rest *E*, which may then be omitted. By flattening the middle of the rest *D* it will be adapted to retain the ends of the strips laid thereon until they are separated and permitted to slide down to enter the machine, and thus the attendant will be relieved from the labor of holding the rear ends of the strips while they are resting on the supports awaiting their turn to enter the matcher.

Longitudinal grooved guides *a*² are arranged on the sides of the machine *B*, to catch the strips at the lower ends of the inclined guides and direct them between the matching-heads. While the two strips are passing through the matching-machine the attendant brings two more into position to succeed them, and so on repeatedly, the construction and arrangement of the machines, and the manner in which the work is divided between them, enabling one attendant to feed the duplex matcher with ease, and to surface and match more than double the amount of lumber that he can under the ordinary mode of operation, and also avoiding the usual accumulation of the strips at the delivery end of the ripping-machine, and the consequent extra labor of laying them down and taking them up.

It is obvious that the saving of time and increase in production are owing not only to the use of the series of ripping-saws and the duplex matching-machine, but also to the fact that the ripping-machine surfaces the strips, in consequence of which the matching-machine may be driven at a far greater speed than when it is compelled, as usual, to surface the strips also. The special arrangement of the two special machines in relation to each other, and the employment of the intermediate supports and the inclined dividing-guides, also facilitates the operation, and enables the attendant to handle the strips with a rapidity and ease that would otherwise be impossible.

In practice, I find that two men operating with the machines constructed and arranged on my plan, as above described, can rip, surface, and match from forty to sixty thousand feet of lumber per day, according to the character of the wood and the width of the strips.

Having thus described the general construction and operation of the two machines, I will now describe more in detail the machine for ripping and surfacing.

The machine consists, first, of a horizontal bed or frame, *b*, on which to place the rough boards, provided on opposite sides with guides *c*, and at its middle with arms *d*, to bear against the inner edges of the boards and press them outward against the side guides, two boards being fed into the machine at the same time. The presser-arms *d*, which are made somewhat elastic, are attached at their inner ends to short vertical shafts, provided with hand-levers *e*, which extend out in front of the machine, so that the attendant grasping their ends may readily adjust the presser-arms, independently of each other, to suit the widths of the boards which may be introduced. For the purpose of locking the levers and presser-arms a rack-bar, *f*, is mounted in the main frame, as shown. At the inner end of the front frame there are mounted on a transverse shaft, *h*, a series of circular ripping-saws, *g*, the saws being attached to hubs or collars, prevented by a spline from turning on the shaft, but at the same time free to slide side-wise thereon. Each saw-carrying hub or col-

lar is provided with a circumferential groove, and in the frame there are mounted a series of independent horizontal hand-levers, *i*, the inner ends of which are engaged with studs or arms seated in the grooved hubs, as shown, so that by moving said levers the saws may be moved independently of each other on the shaft, and the spaces between them varied to produce strips of any required width or widths.

For the purpose of locking the levers and saws in position, I mount below the levers a stationary transverse rack-bar, *K*, as shown in Figs. 2 and 5, and pass the ends of the levers through a horizontal slot in a vertically-moving frame or gate, *l*, which latter is raised and lowered by means of arms on a transverse rock-shaft, *m*, which is in turn connected by an arm and pitman with an upright hand-lever, *n*, mounted on the side of the machine. When the lever is thrown in one direction it raises the gate and lifts the levers out of the rack, leaving them free to move the saws; but after the adjustment has been made, the reverse movement of the lever causes the gate to force the horizontal levers *i* down into the rack, and thereby locks them and the saws in position. The notches or teeth in the rack to receive the levers are arranged at certain graduated distances apart, in order that the saws may produce the strips of the graduated widths known in the market and to the trade, as before mentioned.

For the purpose of facilitating the adjustment of the saws, the horizontal levers and notches in the rack-bars are made of a ∇ form, so that after the levers are in about the positions required the gate will force them home into the notches and bring them to the exact positions required.

In order that the saws may be raised and lowered, as the thickness of the lumber may require, their shaft or arbor is mounted in a vertically-sliding shoe or support attached to the main frame, and secured by suitable devices, such as screws, bolts, or pins. To facilitate the vertical adjustment of the saw shaft or arbor, and insure an equal adjustment of its two ends, I propose to provide its supporting-shoe with a shaft carrying two pinions engaging in stationary racks on opposite sides of the main frame.

For the purpose of supporting the boards as they pass to the saws, and avoiding the friction, a transverse roller, *o*, is mounted in the main frame in advance of the saws, as shown. Behind the saws I mount, in bearings on the main frame, a transverse rotary surfacing or planing head, *H*, extending entirely across the machine, and serving to dress the under side of all the strips at once as they pass backward from the saws. The construction of this head may be varied; but I prefer to use the peculiar head represented in the drawings, and which will be hereinafter explained in detail.

In advance of the surfacing-head I arrange

in line with each other two press-rolls, *p p'*, each extending half-way across the machine. These rolls are mounted in bearings in the upper ends of two independent vertically-sliding frames, *g*, which are mounted in the main frame, and urged upward by weighted levers *r*, so that the two rolls are pushed upward independently of each other against the under sides of the two boards fed into opposite sides of the machine, each board receiving the pressure of one roll. By thus arranging the two press-rolls the two boards are held independently of each other, and thus boards of unequal thickness, which are very frequent, may be held independently while passing the cutter-head. Behind the surfacing head or cutter I mount a supporting-roll, *s*, in a vertically-sliding frame, *t*, which latter is urged upward by a weighted arm, *u*, as shown. The roll *s*, bearing against the under planed surface of the strips, sustains and guides them with accuracy and smoothness, and causes the machine to produce a much smoother and better surface than can be attained in machines in which the guiding or supporting rolls, to regulate the cutting action, travel on the rough unfinished back of the wood.

The downward pressure of the strips upon the cutter is produced by means of an endless revolving bed, *w*, composed of transverse metal slats, hinged together and mounted on carrying-pulleys *b²* on transverse shafts, as shown in Figs. 1 and 2. The shafts which carry the bed are mounted in a vertically-adjustable frame, sliding in guides in the main frame.

As shown in Fig. 7, each bar or slat of the endless bed is cast complete in one piece, with two transverse ribs, *a¹*, the ends of which are fashioned into ears, to receive the pivot-pins by which the slats are united. Each rib *a¹* is provided with a middle tooth, *b¹*, on the inside, to receive the pressure of teeth formed on the supporting-pulleys.

I do not claim, broadly, a slat for planer-beds having ears by which to connect it with the adjacent slats, being aware that slats of this character are old. My slats, however, differ from those hitherto in use, in that each one has double ears on one side and single ears on the other, so that all the slats used are duplicates of each other, and may all be cast from the same pattern; and also in that they have the inside middle teeth *b¹* arranged in the manner shown. The slatted beds hitherto employed had their slats provided alternately with single and double connecting lugs or ears, requiring the use of two different patterns and two different sets of tools in their manufacture, and greatly increasing their cost.

The driving-wheels *b²* have their teeth arranged to ride under the middle of each slat, in the manner shown in Fig. 2, so that, in passing around the end, the slats rock or tip upon the ends of the teeth easily and smoothly,

the action being specially beneficial in connection with the passage of the slats between the guides upon which their ends slide.

The teeth of pulleys b^2 , as shown in Fig. 2, bear under the middle of the ribs a^1 and against the teeth b^1 in such manner as to sustain and advance the bed, the pulleys being driven in any suitable manner.

The ends of the slats slide between and are guided and supported by rigid guide-bars c' below them and similar guides d' above them, as shown in Fig. 2. The under guides c' support the ends of the slats as they assume a horizontal position on the strips, and prevent their corners or edges from dropping below the face of the bed and indenting or marking the strips. When the material used is surfaced on the back, this prevention of its being marked by the slats is an important feature.

The surfacing or cutting head consists, as shown in Figs. 2 and 6, of a shaft provided, at suitable distances apart, with circular disks or clamping-heads, e' , and of a series of knives or cutters, f' , secured thereto. The disks are provided with annular concentric grooves in their side faces, one in each disk, and the cutters are provided with lips which enter and are held by the grooves, as shown. The lips held by the two end disks are formed on the ends of the knives; but the lips of the middle disks, which sustain the knives at their middle, are formed at the side of grooves cut in the inside faces of the knives, as shown.

The disk at one end is movable lengthwise of the shaft, and is forced up against the end of the knives by a nut, v' , mounted on a screw-thread on the shaft. The annular groove in the movable disk is in the side facing the other disks, all of which have their grooves in the sides facing the movable disk, so that the forcing up of the latter by the nut forces the lips of all the cutters firmly into the annular grooves, and secures them rigidly in place.

Thus, it will be seen the single nut serves to secure the cutters in place, and to release them all, when desired, doing away with the labor, expense, and danger incident to the use of the numerous fastening-bolts hitherto employed.

The knives are made with outer surfaces curved in the arc of a circle, and are exact counterparts of each other, so that, when ground to the same length and applied to the grooved disks, they must all cut in the same plane.

The use of two grooved disks or heads to secure the ends of the cutters in the manner shown forms the subject of a separate application, hitherto filed by me, and constitutes no part of the present invention.

The construction of this cutter-head will be made the subject of a separate application, and therefore forms no part of the present patent.

Behind the cutter-head the machine has a

bed or table, m' , on which the strips are delivered with their under faces dressed, and from which they are passed in the manner hereinbefore described to the second machine.

In order that the ripping-saws may be quickly and accurately adjusted to produce strips of any particular width desired, I provide the adjusting-levers e each with a graduated arm or indicator, n' , extending across the next lever of the series, as shown. By means of these indicators the distance between the levers may be instantly ascertained, and adjusted to produce the required spaces between the saws. It will be observed, on referring to Fig. 2, that the space below the cutter-head is inclosed or boxed up in such manner as to form a flue or chamber to receive the chips and shavings, and through which all dust and dirt may be drawn off through an exhaust-fan, saving the attendants from annoyance, and preventing chips from passing between the rolls and the wood.

It will be observed that this closed chamber or trunk bears a special relation to the surfacing-cylinder arranged to dress the under side of the lumber, the position of the parts being such that the chips and shavings produced by the action of the cylinder are compelled to enter the chamber, in which they are retained.

I am aware that it has been proposed to attach segmental saw-blades to a surfacing-head, in order to adapt it for both surfacing and ripping boards; and therefore I do not claim, broadly, a machine capable of performing said two operations.

Having thus described my invention, what I claim is—

1. In combination with a ripping and surfacing machine and a duplex matching-machine, intermediate devices, substantially such as shown and described, to facilitate the feeding of the strips from the first machine to the second.

2. The rests C C', D D', and E, arranged in connection with the ripping and surfacing and the matching machines, substantially as shown and described.

3. The combination, substantially as shown and described, of a multiple ripping and surfacing machine, a duplex matching-machine, and devices constructed and arranged substantially as shown to enable a single attendant to feed two strips at a time from the first machine to the second, as set forth.

4. A machine for ripping and surfacing lumber, consisting of a series of laterally-adjustable ripping-saws mounted on a common shaft, a separate independent surfacing head or cylinder, and feeding devices, substantially such as shown, adapted to pass the boards to the saw and surfer successively.

5. The combination, in one machine, of the series of saws and their adjusting-levers, the surfacing-cylinder H, and endless bed w , arranged for joint operation on the lumber, as described.

6. In combination with the surfacing head

or cutter, extending entirely across the machine, the two independent press-rolls $p p'$, arranged substantially as shown, whereby the machine is adapted for surfacing simultaneously two boards or strips of different thicknesses.

7. In combination with the series of ripping-saws, the guides c and the two arms d , with their levers C and the rack-bar f , substantially as shown.

8. In combination with the laterally-adjustable saws g and their adjusting-levers i , the rack-bar k and the adjustable gate l , as shown.

9. In combination with the endless slatted bed, having single central teeth b^1 under the ends of each slat, the driving pulleys or wheels b^2 , having their teeth arranged to act singly and centrally under the ends of the slats against the teeth b^1 , in the manner shown.

10. In combination with the laterally-ad-

justable saws and their adjusting-levers i , the indicator arms or plates, attached to the levers as shown.

11. In a wood planing or surfacing machine, the combination of an endless slatted bed, w , and supporting wheels or rolls, with fixed guides c' , arranged to receive and sustain the ends of the slats on their front faces, as shown and described, for the purpose of preventing the corners of the slats from marking the lumber.

12. In combination with the bed w and wheels b^2 , constructed in the peculiar manner shown, the fixed guides c' and d' , arranged to bear on the front and rear sides of the slats, as shown.

JOHN DU BOIS.

Witnesses:

P. T. DODGE,
W. C. DODGE.