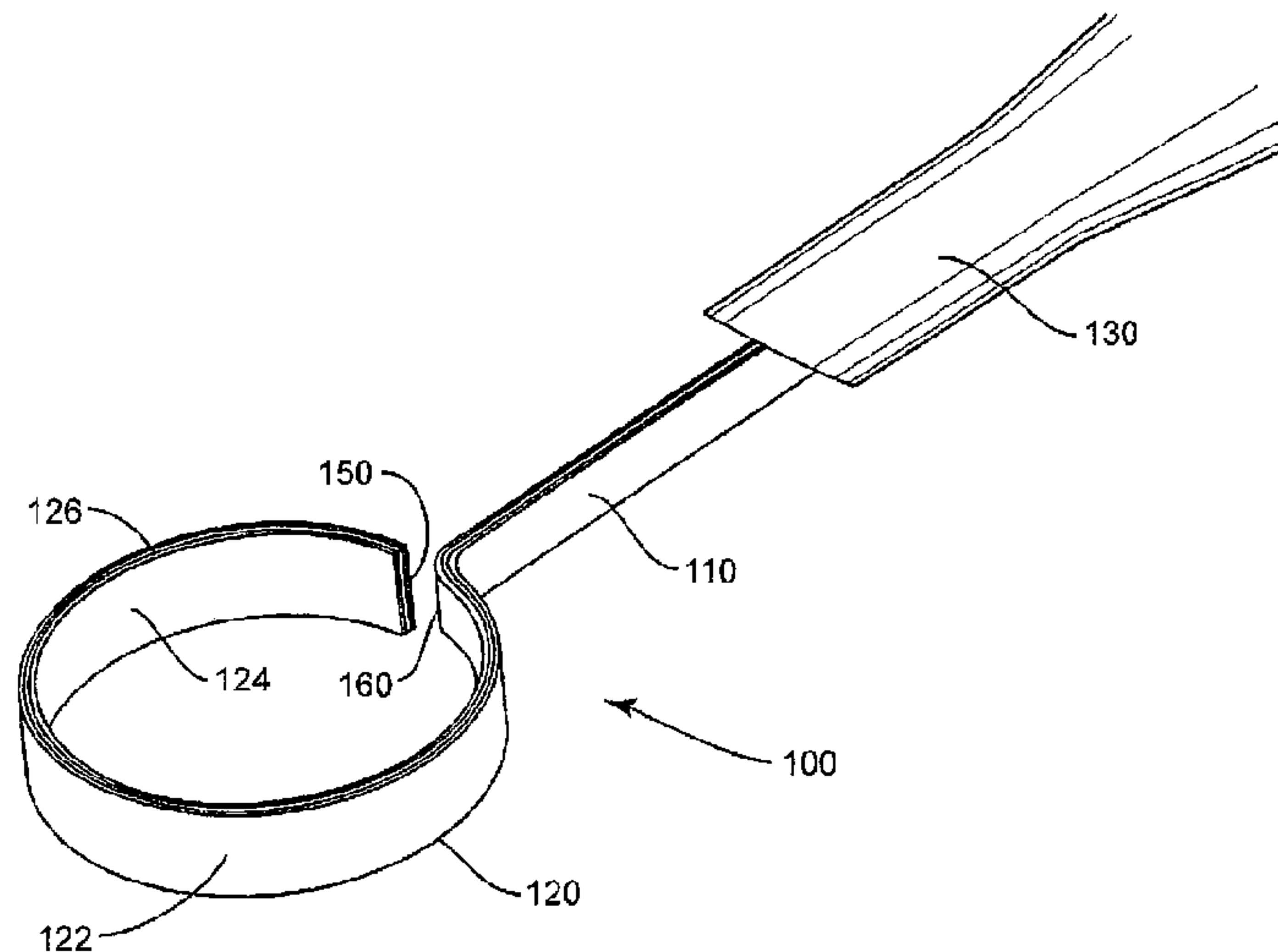




(86) Date de dépôt PCT/PCT Filing Date: 2010/01/07  
 (87) Date publication PCT/PCT Publication Date: 2010/07/15  
 (45) Date de délivrance/Issue Date: 2017/06/20  
 (85) Entrée phase nationale/National Entry: 2011/06/22  
 (86) N° demande PCT/PCT Application No.: US 2010/020295  
 (87) N° publication PCT/PCT Publication No.: 2010/080859  
 (30) Priorité/Priority: 2009/01/12 (US12/351,898)

(51) Cl.Int./Int.Cl. *A61F 9/007* (2006.01)  
 (72) Inventeurs/Inventors:  
 BOUKHNY, MIKHAIL, US;  
 CHON, JAMES, US  
 (73) Propriétaire/Owner:  
 ALCON RESEARCH, LTD., US  
 (74) Agent: KIRBY EADES GALE BAKER

(54) Titre : DISPOSITIF DE CAPSULORHEXIS A ELECTRODES BIPOLAIRES ESCAMOTABLES  
 (54) Title: CAPSULARHEXIS DEVICE WITH RETRACTABLE BIPOLAR ELECTRODES



(57) Abrégé/Abstract:

A capsularhexis device includes a loop-shaped cutting portion formed from flexible, superelastic metal strips separated by an insulating layer, and configured so that the cutting portion may be retracted into a tubular insertion cartridge for insertion into and removal from the eye, and extended from the insertion cartridge for the capsularhexis procedure. In its extended configuration, the cutting portion forms a cutting loop such that a free end of the cutting loop is proximate a connecting end of the cutting loop, with the connecting end joined to a shaft portion. The shaft portion extends into the insertion capsule, and is used to move the cutting portion in and out of the insertion cartridge.

(12) INTERNATIONAL APPLICATION PUBLISHED UNDER THE PATENT COOPERATION TREATY (PCT)

(19) World Intellectual Property Organization  
International Bureau(43) International Publication Date  
15 July 2010 (15.07.2010)(10) International Publication Number  
**WO 2010/080859 A1**

(51) International Patent Classification:

A61F 9/007 (2006.01)

(21) International Application Number:

PCT/US2010/020295

(22) International Filing Date:

7 January 2010 (07.01.2010)

(25) Filing Language:

English

(26) Publication Language:

English

(30) Priority Data:

12/351,898 12 January 2009 (12.01.2009) US

(71) Applicant (for all designated States except US): **ALCON RESEARCH, LTD.** [US/US]; 6201 South Freeway, Fort Worth, TX 76134 (US).

(72) Inventors; and

(75) Inventors/Applicants (for US only): **BOUKHNY, Mikhail** [US/US]; 28356 Chat Drive, Laguna Niguel, CA 92677 (US). **CHON, James** [US/US]; 115 W. Yale Loop, Irvine, CA 92604 (US).(74) Agents: **BASSINGER, Kenneth, D.** et al.; 6201 South Freeway, TB4-8, Fort Worth, TX 76134 (US).

(81) Designated States (unless otherwise indicated, for every kind of national protection available): AE, AG, AL, AM,

AO, AT, AU, AZ, BA, BB, BG, BH, BR, BW, BY, BZ, CA, CH, CL, CN, CO, CR, CU, CZ, DE, DK, DM, DO, DZ, EC, EE, EG, ES, FI, GB, GD, GE, GH, GM, GT, HN, HR, HU, ID, IL, IN, IS, JP, KE, KG, KM, KN, KP, KR, KZ, LA, LC, LK, LR, LS, LT, LU, LY, MA, MD, ME, MG, MK, MN, MW, MX, MY, MZ, NA, NG, NI, NO, NZ, OM, PE, PG, PH, PL, PT, RO, RS, RU, SC, SD, SE, SG, SK, SL, SM, ST, SV, SY, TH, TJ, TM, TN, TR, TT, TZ, UA, UG, US, UZ, VC, VN, ZA, ZM, ZW.

(84) Designated States (unless otherwise indicated, for every kind of regional protection available): ARIPO (BW, GH, GM, KE, LS, MW, MZ, NA, SD, SL, SZ, TZ, UG, ZM, ZW), Eurasian (AM, AZ, BY, KG, KZ, MD, RU, TJ, TM), European (AT, BE, BG, CH, CY, CZ, DE, DK, EE, ES, FI, FR, GB, GR, HR, HU, IE, IS, IT, LT, LU, LV, MC, MK, MT, NL, NO, PL, PT, RO, SE, SI, SK, SM, TR), OAPI (BF, BJ, CF, CG, CI, CM, GA, GN, GQ, GW, ML, MR, NE, SN, TD, TG).

Published:

- with international search report (Art. 21(3))
- before the expiration of the time limit for amending the claims and to be republished in the event of receipt of amendments (Rule 48.2(h))

(54) Title: CAPSULARHEXIS DEVICE WITH RETRACTABLE BIPOLAR ELECTRODES

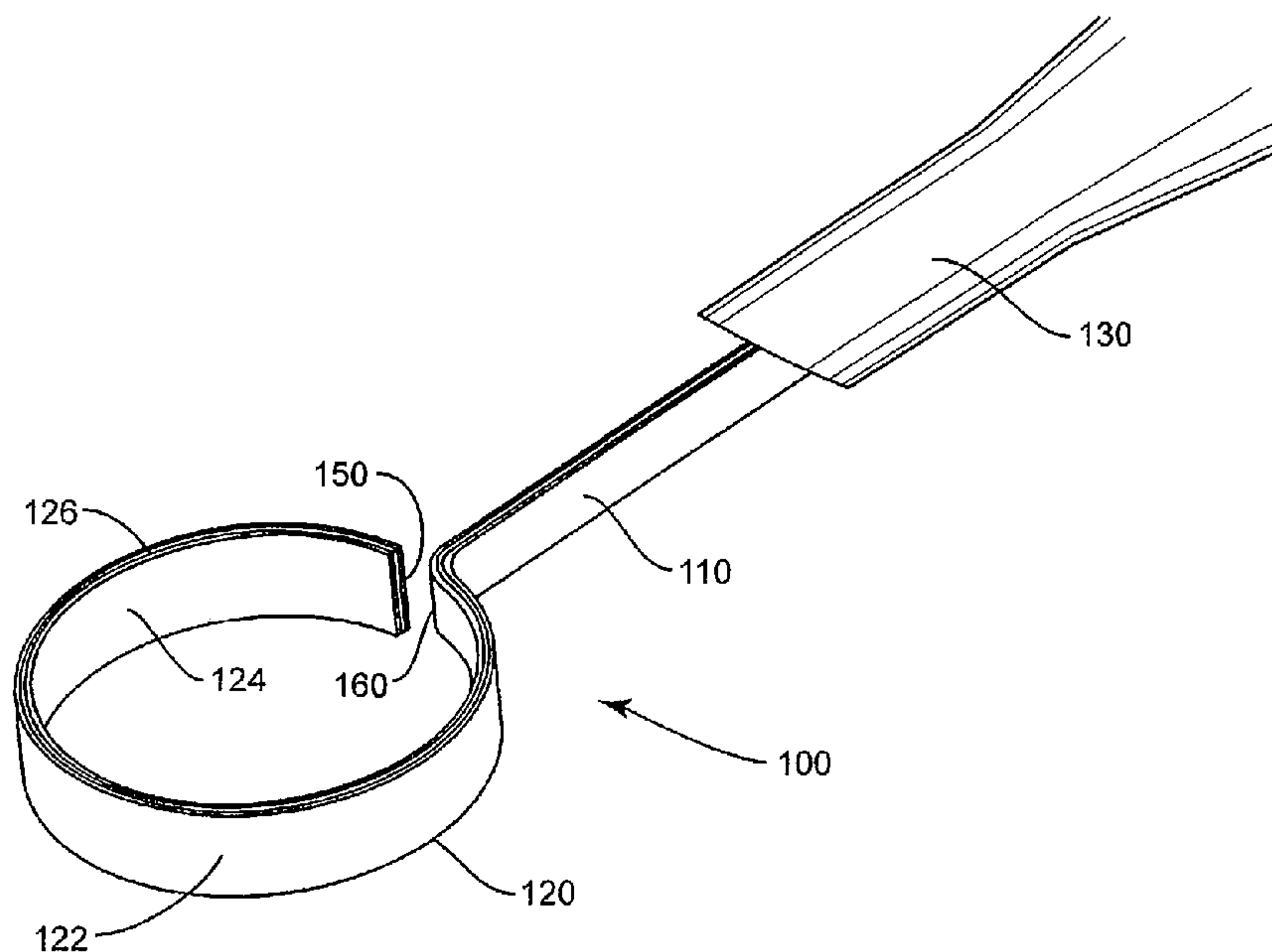


FIG. 1

(57) Abstract: A capsularhexis device includes a loop-shaped cutting portion formed from flexible, superelastic metal strips separated by an insulating layer, and configured so that the cutting portion may be retracted into a tubular insertion cartridge for insertion into and removal from the eye, and extended from the insertion cartridge for the capsularhexis procedure. In its extended configuration, the cutting portion forms a cutting loop such that a free end of the cutting loop is proximate a connecting end of the cutting loop, with the connecting end joined to a shaft portion. The shaft portion extends into the insertion capsule, and is used to move the cutting portion in and out of the insertion cartridge.

WO 2010/080859 A1

## CAPSULARHEXIS DEVICE WITH RETRACTABLE BIPOLAR ELECTRODES

### TECHNICAL FIELD

5           The present invention relates generally to the field of cataract surgery and more particularly to methods and apparatus for performing a capsularhexis.

### BACKGROUND

10           An accepted treatment for the treatment of cataracts is surgical removal of the lens and replacement of the lens function by an artificial intraocular lens (IOL). In the United States, the majority of cataractous lenses are removed by a surgical technique called phacoemulsification. Prior to removing the cataractous lens, an opening, or rhexis, must be made in the anterior capsule. During phacoemulsification, there is a great deal of tension on the cut edges of the anterior capsularhexis while the lens nucleus is emulsified. Accordingly, a continuous cut or  
15           tear (rhexis), without "tags," is a critical step in a safe and effective phacoemulsification procedure.

20           If the capsule is opened with numerous small capsular tears, the small tags that remain can lead to radial capsular tears which may extend into the posterior capsule. Such a radial tear constitutes a complication since it destabilizes the lens for further cataract removal and safe intraocular lens placement within the lens capsule later in the operation. Further, if the posterior capsule is punctured then the vitreous may gain access to the anterior chamber of the eye. If this happens, the vitreous  
25           must be removed by an additional procedure with special instruments. The loss of vitreous is also associated with an increased rate of subsequent retinal detachment and/or infection within the eye. Importantly, these complications are potentially blinding.

30           Conventional equipment used for phacoemulsification includes an ultrasonically driven handpiece with an attached cutting tip. In some of these handpieces, the operative part is a centrally located, hollow resonating bar or horn directly attached to a set of piezoelectric crystals. The crystals supply ultrasonic vibration for driving both the horn and the attached cutting tip during  
35           phacoemulsification.

          Prior art devices and methods used for the capsularhexis procedure require a great deal of skill on the part of the surgeon to produce a continuous curvilinear

capsular opening. This is due to the extreme difficulty in controlling the path of the cutting tip of the device. For example, a typical procedure begins with a capsular incision made with a cystotome, e.g., a cutting tip as described above. This incision is then coaxed into a circular or oval shape by pushing the leading edge of the incision in the capsule, using the cystotome as a wedge rather than in a cutting fashion. Alternatively, the initial capsular incision may be torn into a circular shape by grasping the leading edge with fine caliber forceps and advancing the cut. Either of these approaches involves a very challenging maneuver and the tearing motion can sometimes lead to an undesirable tear of the capsule toward the back of the lens, even in the most experienced hands.

Moreover, even if a smooth capsular opening without tags is ultimately produced, the size and/or position of the capsular opening may present a problem. For instance, a capsular opening that is too small can impede the safe removal of the lens nucleus and cortex and prevent proper intraocular lens insertion into the lens capsule. The additional stresses necessary to accomplish the operation with a small or misplaced capsular opening put the eye at risk for zonular and capsular breakage. Either of these complications will likely increase the length and complexity of the operation and may result in vitreous loss.

A continuous, properly positioned, and circular opening is thus highly desirable because it results in: (1) a significant reduction in radial tears and tags within the anterior capsule, (2) capsule integrity necessary for proper centering of a lens prosthesis; (3) safe and effective hydrodissection; and (4) safe use of capsular procedures on patients having poorly visualized capsules and/or small pupil openings. In addition, the capsularhexis should be properly dimensioned relative to the diameter of the IOL being implanted in order to reduce the chances of a secondary cataract, also called posterior capsule opacification ("PCO") and for use with proposed accommodative IOLs designs. Therefore, there is a continuing need for an improved device for performing an anterior chamber capsularhexis.

## SUMMARY

Various embodiments of the present invention provide apparatus and corresponding methods of use for performing capsularhexis. In several embodiments, a capsularhexis device includes a loop-shaped cutting portion formed from flexible, superelastic metal strips separated by an insulating layer, and configured so that the cutting portion may be retracted into a tubular insertion cartridge for insertion into and removal from the eye, and extended from the insertion

cartridge for the capsularhexis procedure. In its extended configuration, the cutting portion forms a cutting loop such that a free end of the cutting loop is proximate a connecting end of the cutting loop, with the connecting end joined to a shaft portion. The shaft portion extends into the insertion capsule, and is used to move the cutting portion in and out of the  
5 insertion cartridge.

Certain exemplary embodiments can provide a capsularhexis device, comprising: a tubular insertion cartridge having a proximal end for engagement to a handpiece and a distal end for insertion into an eye; a shaft portion configured for longitudinal translation within the tubular insertion cartridge and comprising first and second electrical leads for  
10 electrical connection to an external power source; and a cutting portion having a connecting end, joined to the shaft portion, and a free end, the cutting portion comprising first and second superelastic electrode layers separated by an electrically insulating layer and electrically connected to the first and second electrical leads, respectively; wherein the capsularhexis device has an extended configuration, in which the cutting portion is external  
15 to the tubular insertion cartridge and forms a cutting loop with a gap in a periphery of the cutting loop, and a retracted configuration, in which the cutting portion is contained substantially within the insertion cartridge such that the connecting end is farther from the distal end of the insertion cartridge than a remainder of the cutting portion; wherein the first and second superelastic electrode layers comprise first and second elongated superelastic  
20 strips, each having a length approximately equal to or greater than the perimeter of the cutting loop, a thickness, and a height; and wherein the first and second superelastic strips sandwich the insulation layer for at least a portion of the length and height of the superelastic strips.

Accordingly, an exemplary embodiment of a capsularhexis device according to  
25 some embodiments of the present invention includes a tubular insertion cartridge having a proximal end for engagement to a handpiece and a distal end for insertion into an eye, a shaft portion configured for longitudinal translation within the tubular insertion cartridge and comprising first and second electrical leads for electrical connection to an external power source, and a cutting portion having a connecting end, joined to the shaft portion, and a  
30 free end. The cutting portion comprises first and second superelastic electrode layers separated by an electrically insulating layer and electrically connected to the first and

second electrical leads, respectively. The cutting portion is formed so that the capsularhexis device of this embodiment has an extended configuration, in which the cutting portion is external to the tubular insertion cartridge and forms a cutting loop with the free end proximate the connecting end and separated from the connecting end by a gap in the periphery of the cutting loop, as well as a retracted configuration, in which the cutting portion is contained substantially within the insertion cartridge such that the connecting end is farther from the distal end of the insertion cartridge than the remainder of the cutting portion.

In some embodiments, the superelastic electrode layers of the device's cutting portion are formed from a nickel titanium alloy. In these and other embodiments, the first and second superelastic electrode layers may comprise first and second elongated superelastic strips, each having a length approximately equal to the perimeter of the cutting loop, a thickness, and a height that exceeds the thickness, and be configured so that the first and second superelastic strips sandwich the insulation layer for at least a portion of the length and height of the superelastic strips. The electrically insulating layer may be formed from any suitable matter, including those materials commonly known as Parylene.

An exemplary method for utilizing a capsularhexis device, according to some embodiments of the invention, begins with the positioning of one end of a tubular insertion cartridge in or near the anterior chamber of an eye, the tubular insertion cartridge containing (a) at least a portion of a shaft configured for longitudinal translation within the tubular insertion cartridge and comprising first and second

electrical leads for electrical connection to an external power source, and (b) substantially all of a cutting portion having a connecting end, joined to the shaft, and a free end, the cutting portion comprising first and second superelastic electrode layers separated by an electrically insulating layer and electrically connected to the first and second electrical leads. When the tip of the insertion cartridge is initially positioned in or near the eye, the cutting portion is in a retracted configuration such that the connecting end is farther from the distal end of the insertion cartridge than the remainder of the cutting portion. Using a handle that rigidly engages at least a portion of the shaft, the cutting portion is ejected from the tubular insertion cartridge, into the anterior chamber, so that the cutting portion forms a cutting loop with the free end proximate the connecting end and separated from the connecting end by a gap in the periphery of the cutting loop.

After the cutting loop is positioned in contact with the anterior lens capsule of the eye, a high-frequency electrical current is activated, causing the cutting portion to burn the lens capsule along the cutting loop. The cutting portion is then retracted into the tubular insertion cartridge, using the handle, before removal of the distal end of the tubular insertion cartridge from the eye.

Of course, those skilled in the art will appreciate that the present invention is not limited to the above features, advantages, contexts or examples, and will recognize additional features and advantages upon reading the following detailed description and upon viewing the accompanying drawings.

## **BRIEF DESCRIPTION OF THE DRAWINGS**

Figure 1 is a perspective view of an exemplary capsularhexis device.

Figure 2 illustrates the capsularhexis device of Figure 1, with the device's cutting portion partially retracted into a tubular insertion cartridge.

Figure 3 is a cross-sectional view of an exemplary capsularhexis device retracted into a tubular insertion cartridge.

Figure 4 is a cross sectional view of the cutting portion of an exemplary capsularhexis device.

Figures 5A-5D illustrate the insertion and removal of a capsularhexis device during cataract surgery.

Figure 6 is a process flow diagram illustrating an exemplary method for utilizing a capsularhexis device.

#### DETAILED DESCRIPTION

5 Various embodiments of the present invention provide apparatus and corresponding methods of use for performing capsularhexis. In particular, the present invention relates to a surgical instrument, a so-called capsularhexis device, which may be positioned within the anterior chamber of an eye through a small incision to perform capsularhexis, or capsulotomy. This procedure facilitates phacoemulsification of a cataractous lens and  
10 insertion of an artificial intraocular lens (IOL).

United States Patent Application Publication No. 2006/0100617 (US 10/984,383 filed November 9, 2010, published May 11, 2006) describes a capsularhexis device comprising a circular, flexible ring made of an elastomer or an acrylic or thermoplastic material. Embedded  
15 within each of various embodiments of this flexible ring is either a resistance-heating element or a pair of bipolar electrodes, which are energized according to known techniques to produce localized heating on the anterior capsule, so as to define a weakened boundary for an easy detachment of the portion of the capsule within the circular ring.

20 According to several embodiments of the present invention, the flexible ring structure is replaced with a loop-shaped cutting portion formed from flexible, superelastic metal strips separated by an insulating layer, and configured so that the cutting portion may be retracted into a tubular insertion cartridge for insertion into and removal from the eye. A perspective view of one such embodiment is provided in Figure 1, which shows a capsularhexis device  
25 100 comprising a shaft portion 110, a cutting portion 120, and a tubular insertion cartridge 130. In the view pictured in Figure 1, the capsularhexis device is in an extended configuration such that the cutting portion forms a cutting loop with the free end 150 of the cutting loop proximate a connecting end 160 of the cutting loop, with the connecting end joined to the shaft portion 110.

30 Because the cutting loop is not continuous, but has a small peripheral gap between the free end 150 and the connecting 160 of the cutting portion, the cutting portion can be retracted into the tubular insertion cartridge 130. In the retracted configuration, the distal end of the insertion cartridge, which has a much smaller cross-sectional profile than the extended  
35 cutting loop, can be inserted into a very small incision in the eye, e.g., an incision less than 2 millimeters in length.



This retracted configuration is illustrated in Figure 2, in which the cutting portion 120 has been almost entirely retracted into the insertion cartridge 130, with only a small portion of the cutting portion 120 protruding from the distal end of the tubular insertion cartridge. Figure 3 provides a cross-sectional view of an exemplary capsularhexis device in a fully retracted configuration; in this view the cutting portion 120 has been retracted, using the shaft portion 120 and a handle 130 that rigidly engages the shaft portion 120, and is completely contained within the tubular insertion cartridge 130. In this configuration, the free end 150 of the cutting portion is near the distal end of the insertion cartridge 130, and the connecting end 160 is retracted deep into the cartridge, so that the connecting end 160 is farther from the distal end of the insertion cartridge than the remainder of the cutting portion.

The cutting portion 120 regains its loop shape upon extension from the insertion cartridge 130 because it is formed from materials having superelastic properties. Referring once more to Figure 1, the cutting portion 120 of the pictured capsularhexis device 100 includes two superelastic electrode layers 122 and 124, which are separated by a thin, electrically insulating layer 126 (which may be any suitable material such as Parylene). In particular, the electrode layers 122 and 124 may be formed from a nickel titanium alloy, commonly known as Nitinol, which exhibits superelastic and shape memory properties. Because it is superelastic (which term is intended herein as a synonym for the somewhat more technically precise term "pseudoelastic"), an object made from Nitinol can withstand a significant amount of deformation when a load is applied and return to its original shape when the load is removed. (Those skilled in the art will appreciate that this property is distinct from, although related to, "shape memory", which refers to a property exhibited by some materials in which an object that is deformed while below the material's transformation temperature returns to its former shape when warmed to above the transformation temperature. Nitinol exhibits both properties; superelasticity is exhibited above the transformation temperature.) Accordingly, a cutting portion 120 formed from Nitinol electrodes in the extended, loop-shaped configuration of Figure 1 (e.g., by forming appropriately dimensioned strips into the desired shape and heat-treating at a temperature in the 500°C range) can be deformed into the retracted configuration pictured in Figures 2 and 3, and return to its previous loop shape when extended again.

Because Nitinol is also electrically conductive, the Nitinol layers can serve as bipolar electrodes for applying a high-frequency electrical current to the lens capsule. The current is supplied to the electrodes 122 and 124 through electrical leads

passing through the shaft portion 110 for electrical connection to an external power source (not shown). In Figure 1, the layers that form the electrodes 122 and 124 continue through the visible portion of the shaft portion 110, thus serving as electrical leads for supplying the high-frequency current to the cutting portion 120. In some  
5 embodiments, the Nitinol layers may extend throughout the shaft portion, with an electrical connector, soldered wire leads, or the like, attached to the far end of the shaft portion for supplying the high-frequency current from the external power source. In others, the Nitinol layers may be terminated at various points along the shaft portion, and connected to conventional wire leads, metallic strips of another  
10 electrically conductive material, or the like.

Figure 4 shows a cross-sectional view of the cutting portion 120 applied against a portion of the anterior capsule 410 of an eye. The electrodes 122 and 124 define the boundaries of the portion of the lens capsule that is cauterized by the high-  
15 frequency current when the electrodes are energized. When applied against the anterior lens capsule 410, the spacing between the electrodes 124 and 126 defines a gap across which the high-frequency current flows when the electrodes are energized, burning the intervening lens capsule tissue and weakening it, so that a roughly circular portion of the lens capsule can be easily removed, using forceps.  
20 The basic principles of such electro-surgery, which may involve, for example, frequencies of greater than 100 kHz, are well known to those skilled to the art; accordingly, the details of such procedures, which are not necessary to a complete understanding of the present invention, are not provided herein.

25 Those skilled in the art will appreciate that other materials that are electrically conductive and superelastic may be used instead of Nitinol in some embodiments of the invention. Those skilled in the art will further appreciate that the general shape and/or cross-section of the cutting portion 120 and shaft 110 may vary from that pictured in Figures 1-4. For instance, the embodiment pictured in these figures  
30 includes a cutting portion formed from elongated superelastic strips with rectangular cross sections that sandwich a very thin electrically insulating layer 126, with each strip having a length approximately equal to the perimeter of the of the cutting loop, a relatively small thickness, compared to the diameter of the loop, and a height that is several times the thickness. Other embodiments might employ one or more strips  
35 having height and thickness dimensions that are closer to being equal. In these or other embodiments, one or more of the planar surfaces of Figures 1-2 might be rounded instead. Although a circular capsularhexis is generally preferred, to reduce the possibility of undesirable tearing when the cut portion of the lens is removed, the

cutting loop formed by the cutting portion 120 need not be perfectly circular. Similarly, when the device is in its extended configuration the gap in the periphery of the cutting loop between the free end 150 and the connecting end 160 of the cutting portion 120 should preferably be relatively small, compared to the overall dimensions of the loop, or even touching (e.g., separated only by an insulating layer). However, larger gaps may be acceptable, in some embodiments.

The details of the tubular insertion cartridge 130 and the handle 310 may also from one embodiment to another. In the embodiment pictured in Figure 3, handle 310 is a flat or cylindrical tube that rigidly engages a portion of the shaft section. Handle 310 may thus be used to insert the cutting portion 120 into the eye during the capsularhexis procedure and to retract the cutting portion 120 afterwards, as will be discussed in further detail below. The handle 310, which may be made from an inexpensive material such as a thermoplastic, may also contain electrical connectors and/or connecting wires so that the cutting portion 120 may be selectively connected to a high-frequency power source for the capsularhexis procedure. In some embodiments, the handle 310, shaft portion 110, and cutting portion 120 form a disposable unit that can be selectively connected during use to a handpiece or other apparatus that can supply electrical current; in other embodiments the assembly comprising the handle 310, shaft portion 110, and cutting portion 120 may be cleaned and re-used several times.

Similarly, the insertion cartridge 130 in some embodiments is a disposable polymeric component, while in other embodiments the insertion cartridge 130 may be re-usable and/or may be an integral part of a re-usable capsularhexis handpiece. In any case, the tubular insertion cartridge 130 is generally adapted to accommodate a longitudinally translating shaft portion 110 and a retracted cutting portion 120, as shown in Figure 3, so that the cutting portion 120 may be extended from the distal end of the tubular insertion cartridge 130, into the anterior chamber of an eye, for the capsularhexis procedure. The proximal end of the insertion cartridge engages with the rest of a capsularhexis handpiece, accommodating longitudinal translation of the shaft portion 110 and/or handle 310, to eject and retract the cutting portion 120. Although a mechanism for moving the handle 310 is not shown in Figure 3, those skilled in the art will appreciate that various manual mechanisms (e.g., a tab extending from the handle) or automated mechanisms (e.g., a motorized linear actuator) are possible.

Figures 5A – 5D illustrate the insertion of the cutting portion 120 into an eye 510, using an insertion cartridge 130. Prior to the procedure, the cutting portion 120 has been withdrawn into the insertion cartridge, so that the cutting portion 120 is contained entirely within the cartridge 130. Thus, the leading tip of the apparatus can  
5 be inserted into the anterior chamber 520 of the eye 510, as shown in Figure 5A, through a small incision.

Using handle 310, the retracted cutting portion 120 is pushed through the cartridge 130, as shown in Figure 5B, until it is completely within the anterior  
10 chamber 520, as shown in Figure 5C. When ejected from the insertion cartridge 130 into its extended configuration, the cutting portion 120 regains its pre-determined shape, i.e., forming a cutting loop, as shown in Figure 5C, and is then positioned against the capsule 530. The cutting portion 120 is then energized, e.g., with a short pulse or series of pulses of high-frequency current. As discussed above, this  
15 energizing of the bipolar electrodes sears the capsule 530, effectively creating a smooth continuous cut on the capsule. The cutting portion 120 may then be retracted into the insertion cartridge 130, as shown in Figure 5D, and then removed from the eye 510. The cut portion of the capsule is then readily removed using a conventional surgical instrument, such as forceps.

20

With the above-described device configurations in mind, those skilled in the art will appreciate that Figure 6 illustrates a method for utilizing a capsularhexis device according to some embodiments of the present invention. The illustrated procedure begins with the positioning of an insertion cartridge into the eye, as  
25 illustrated at block 610, and the extension of the cutting portion 120 into the anterior chamber of the eye, as shown at block 620. Because the cutting portion 120 described herein is effectively collapsed when in its retracted configuration, the insertion cartridge 130 may be dimensioned to fit through an incision that is considerably smaller than the expanded diameter of the cutting loop formed by the  
30 extended cutting portion 120.

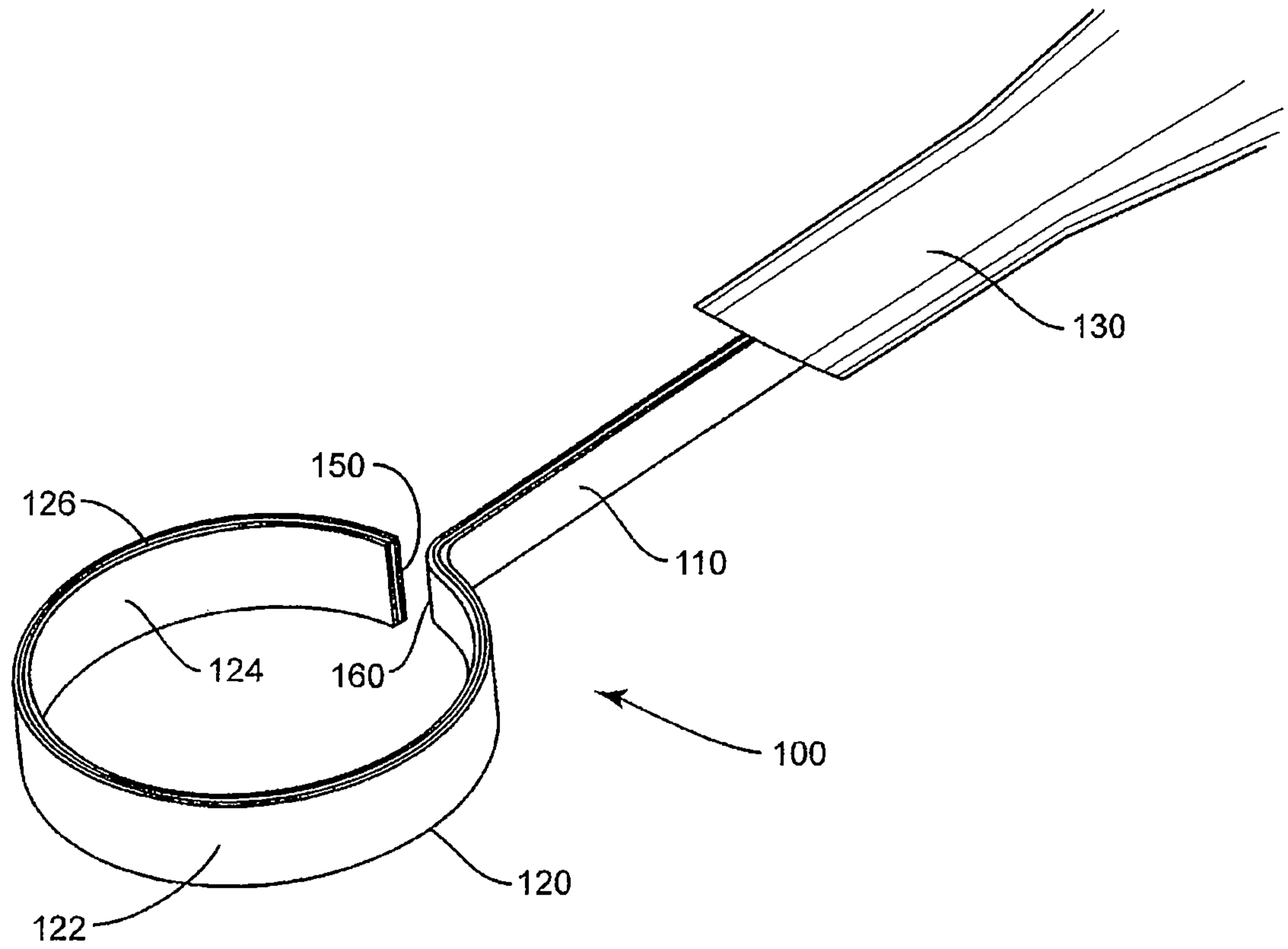
Once the cutting portion 120 is ejected into the eye, the cutting loop may be positioned against the anterior lens capsule, as shown at block 630. After the cutting loop is correctly positioned against the capsule, it is energized by the application of  
35 high-frequency electrical current, as shown at block 640, so that the lens capsule is “burned” along the curve formed by the cutting loop. Once the burning of the capsule is complete, the cutting portion 120 may be retracted into the insertion cartridge, as shown at block 650, and removed from the eye, as shown at block 660.

The preceding description of various embodiments of a capsularhexis device and methods for utilizing a capsularhexis device was given for purposes of illustration and example. Those skilled in the art will appreciate, of course, that the present invention may be carried out in other ways than those specifically set forth herein  
5 without departing from essential characteristics of the invention. The present embodiments are thus to be considered in all respects as illustrative and not restrictive, and all changes coming within the meaning and equivalency range of the appended claims are intended to be embraced therein.

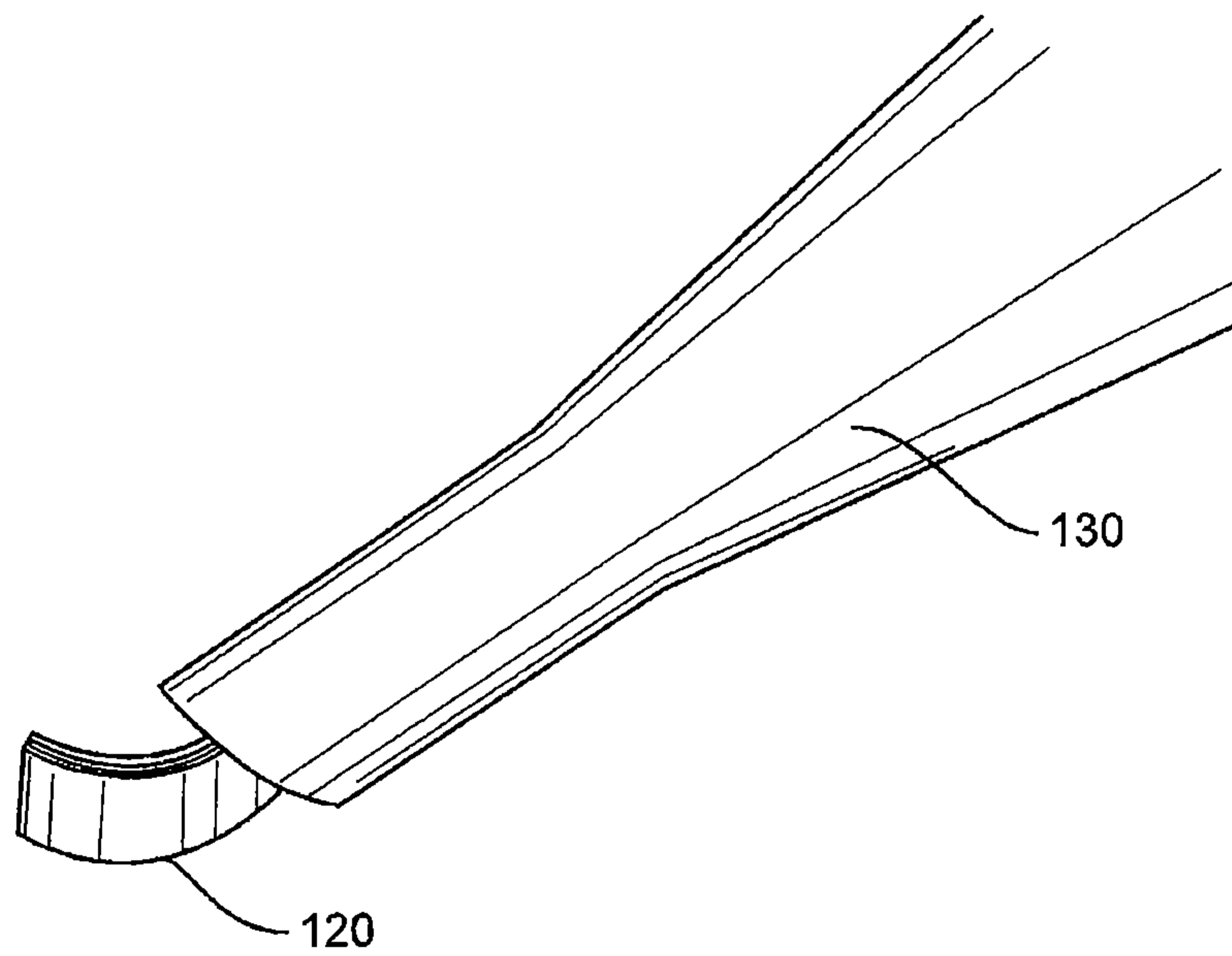
## CLAIMS

1. A capsularhexis device, comprising:
- 5 a tubular insertion cartridge having a proximal end for engagement to a handpiece and a distal end for insertion into an eye;
- a shaft portion configured for longitudinal translation within the tubular insertion cartridge and comprising first and second electrical leads for electrical connection to an external power source; and
- 10 a cutting portion having a connecting end, joined to the shaft portion, and a free end, the cutting portion comprising first and second superelastic electrode layers separated by an electrically insulating layer and electrically connected to the first and second electrical leads, respectively;
- wherein the capsularhexis device has an extended configuration, in which the cutting portion is external to the tubular insertion cartridge and forms a cutting loop with a gap in a periphery of the cutting loop, and a retracted configuration, in which the cutting portion is contained substantially within the insertion cartridge such that the connecting end is farther from the distal end of the insertion cartridge than a remainder of the cutting portion;
- 15 wherein the first and second superelastic electrode layers comprise first and second elongated superelastic strips, each having a length approximately equal to or greater than the perimeter of the cutting loop, a thickness, and a height; and
- wherein the first and second superelastic strips sandwich the insulation layer for at least a portion of the length and height of the superelastic strips.
- 20
2. The capsularhexis device of claim 1, wherein the superelastic electrode layers are formed from a nickel titanium alloy.
3. The capsularhexis device of claim 1, wherein the height of the first and second superelastic electrode layers exceeds the thickness of the first and second superelastic electrode layers.
- 25
- 30

4. The capsularhexis device of claim 1, wherein the distal end of the tubular insertion cartridge is configured to be inserted into an incision less than 2 millimeters in length when the capsularhexis device is in the retracted configuration.
- 5 5. The capsularhexis device of claim 1, wherein the first and second superelastic electrode layers are configured to cauterize a lens capsule of the eye by applying a high-frequency electrical current.
6. The capsularhexis device of claim 1, wherein the first superelastic electrode  
10 layer has a rectangular cross section.
7. The capsularhexis device of claim 1, wherein the height of the first and second superelastic electrode layers approximately equals the thickness of the first and second superelastic electrode layers.  
15
8. The capsularhexis device of claim 1, wherein the cutting loop is approximately circular.
9. The capsularhexis device of claim 1, wherein the gap in the periphery of the  
20 cutting loop is spanned by an insulating layer.
10. The capsularhexis device of claim 1, wherein the cutting loop is configured to be placed against an anterior lens capsule in the eye.

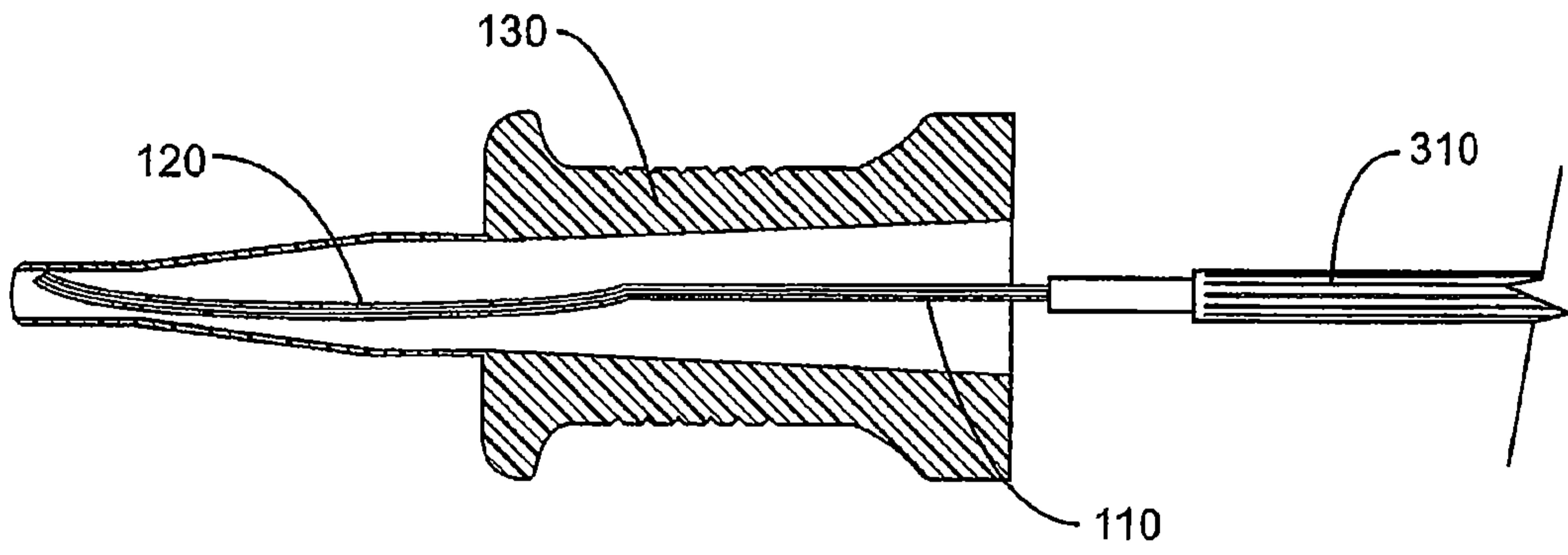


**FIG. 1**

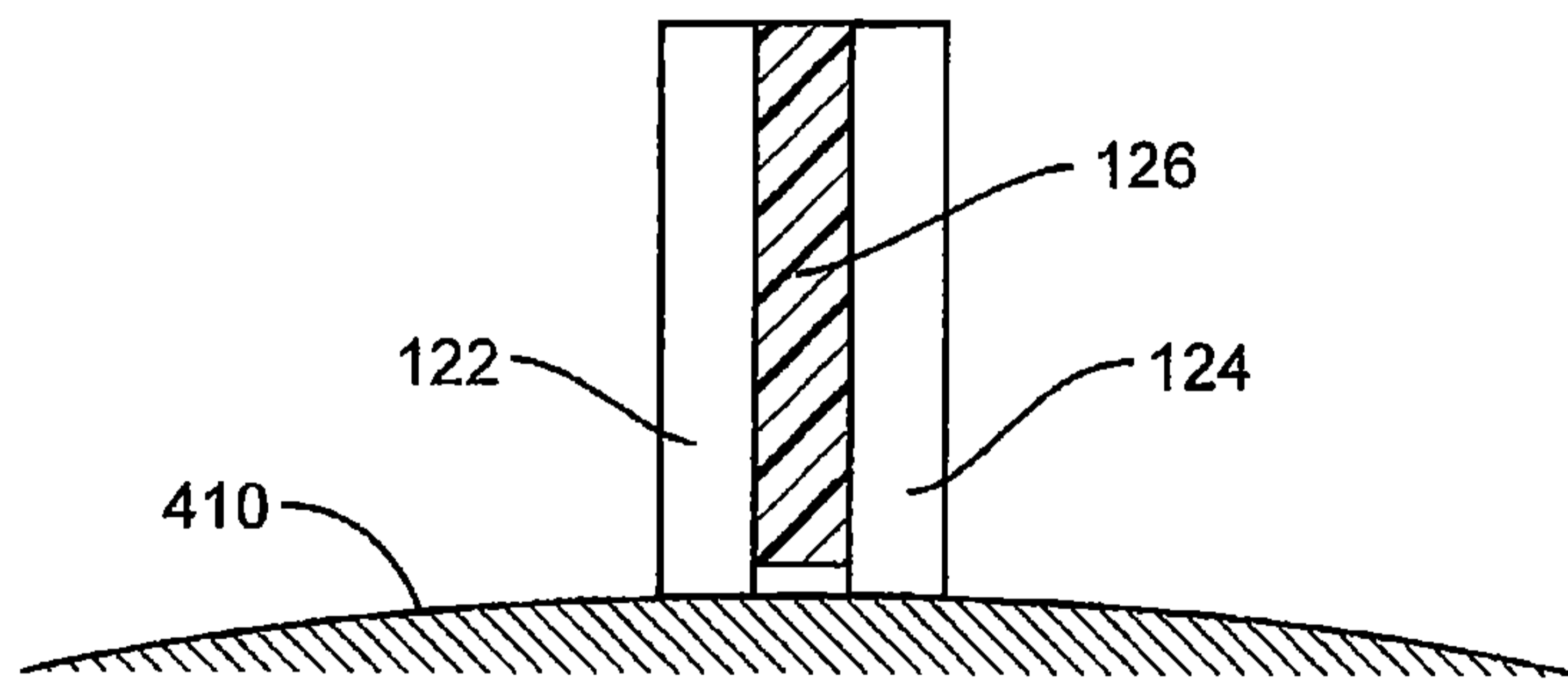


**FIG. 2**

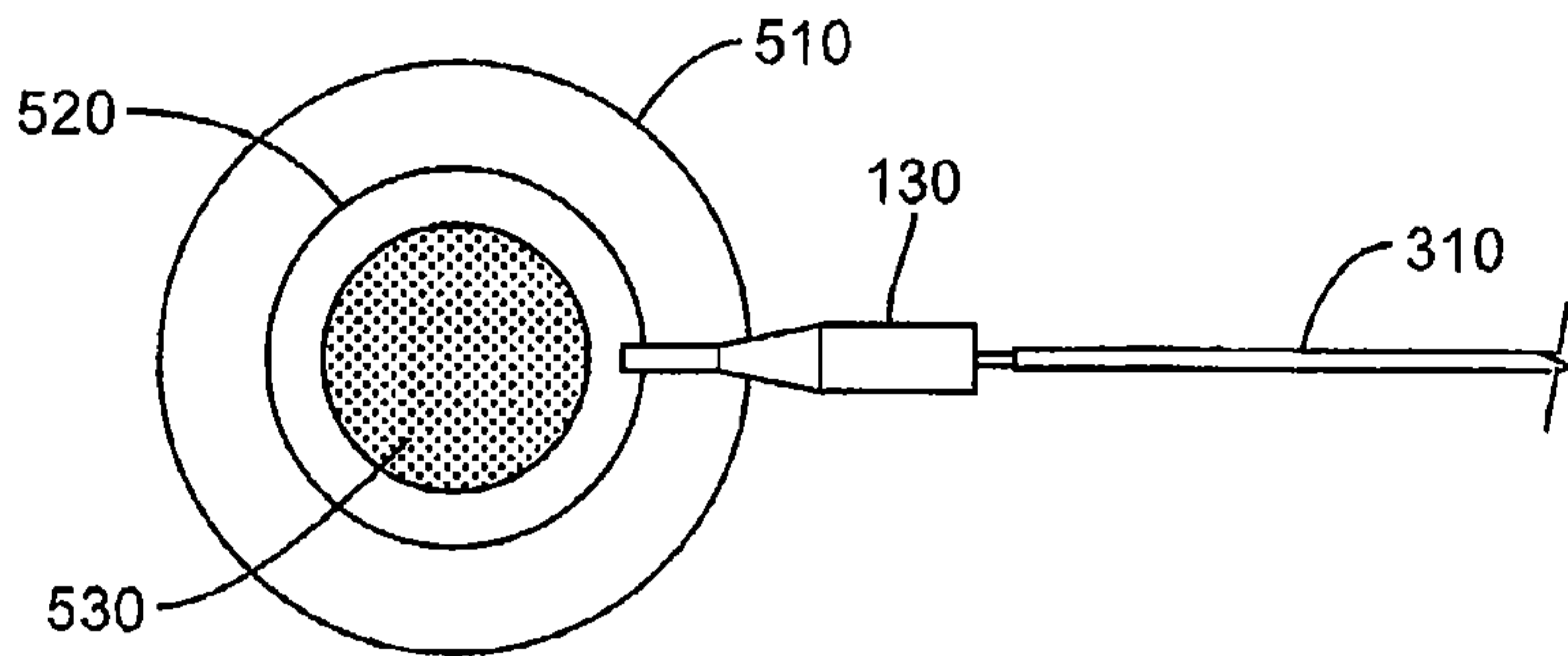




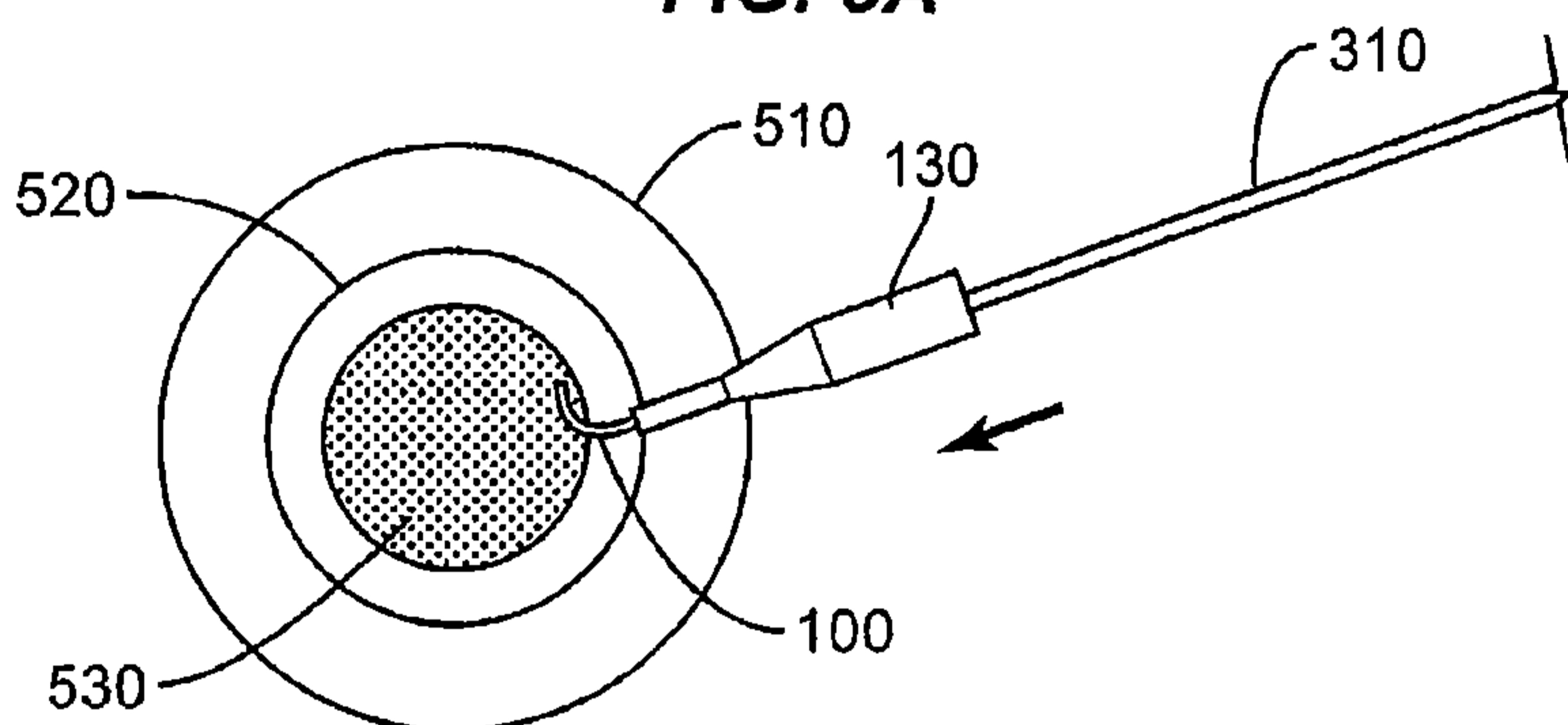
**FIG. 3**



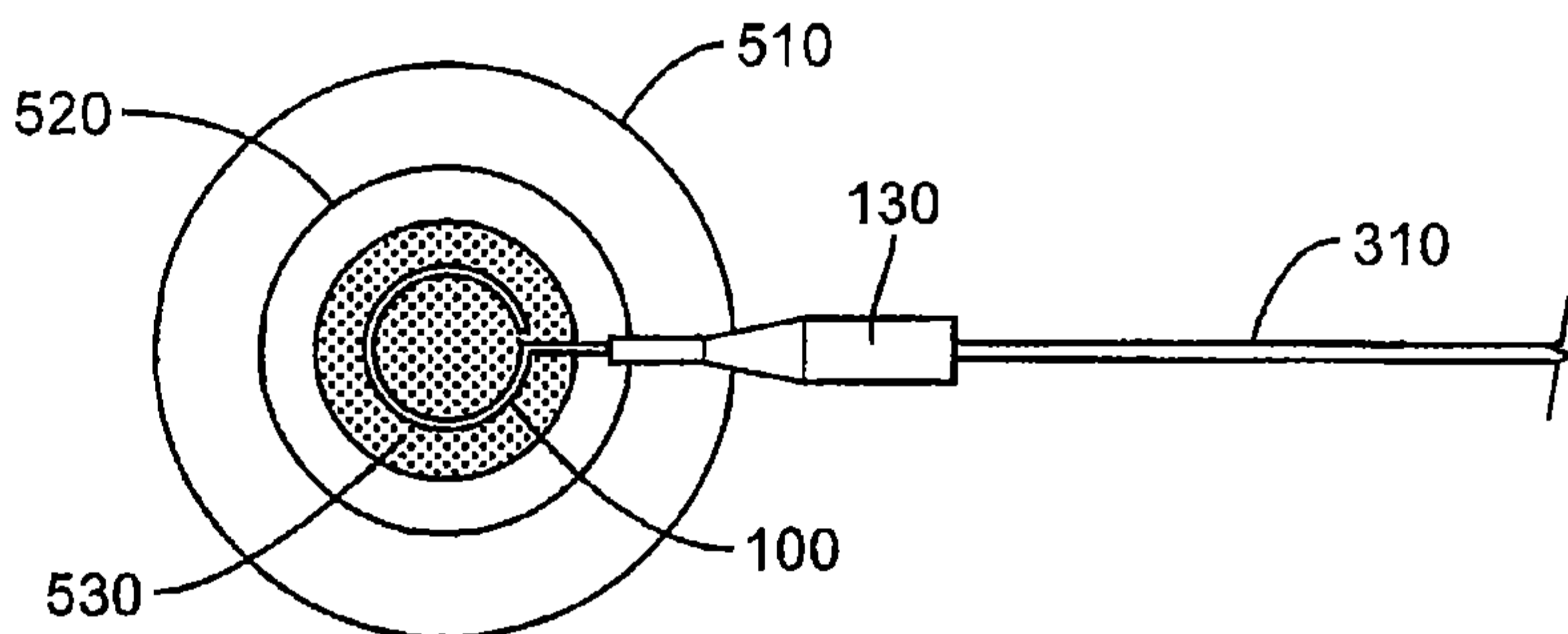
**FIG. 4**



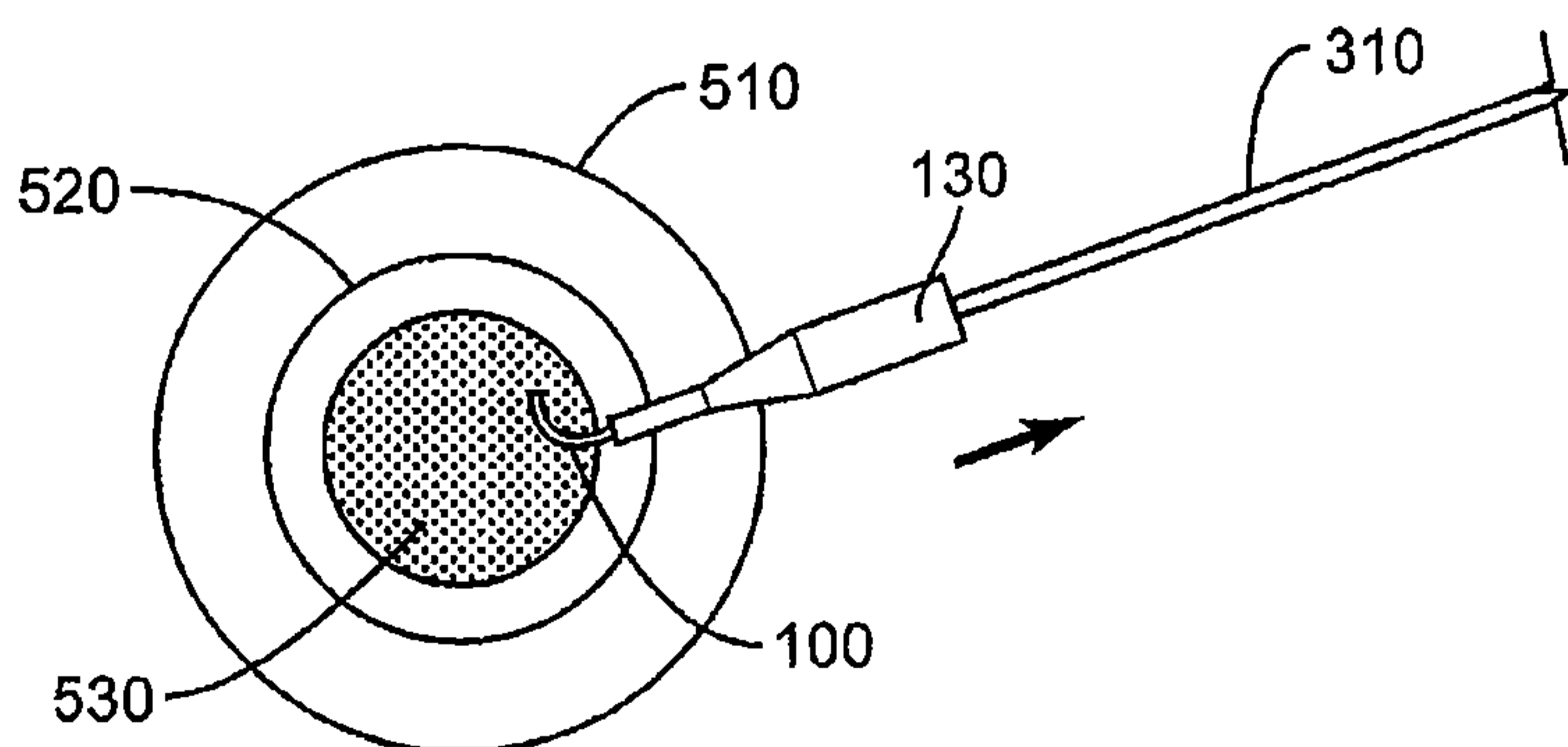
**FIG. 5A**



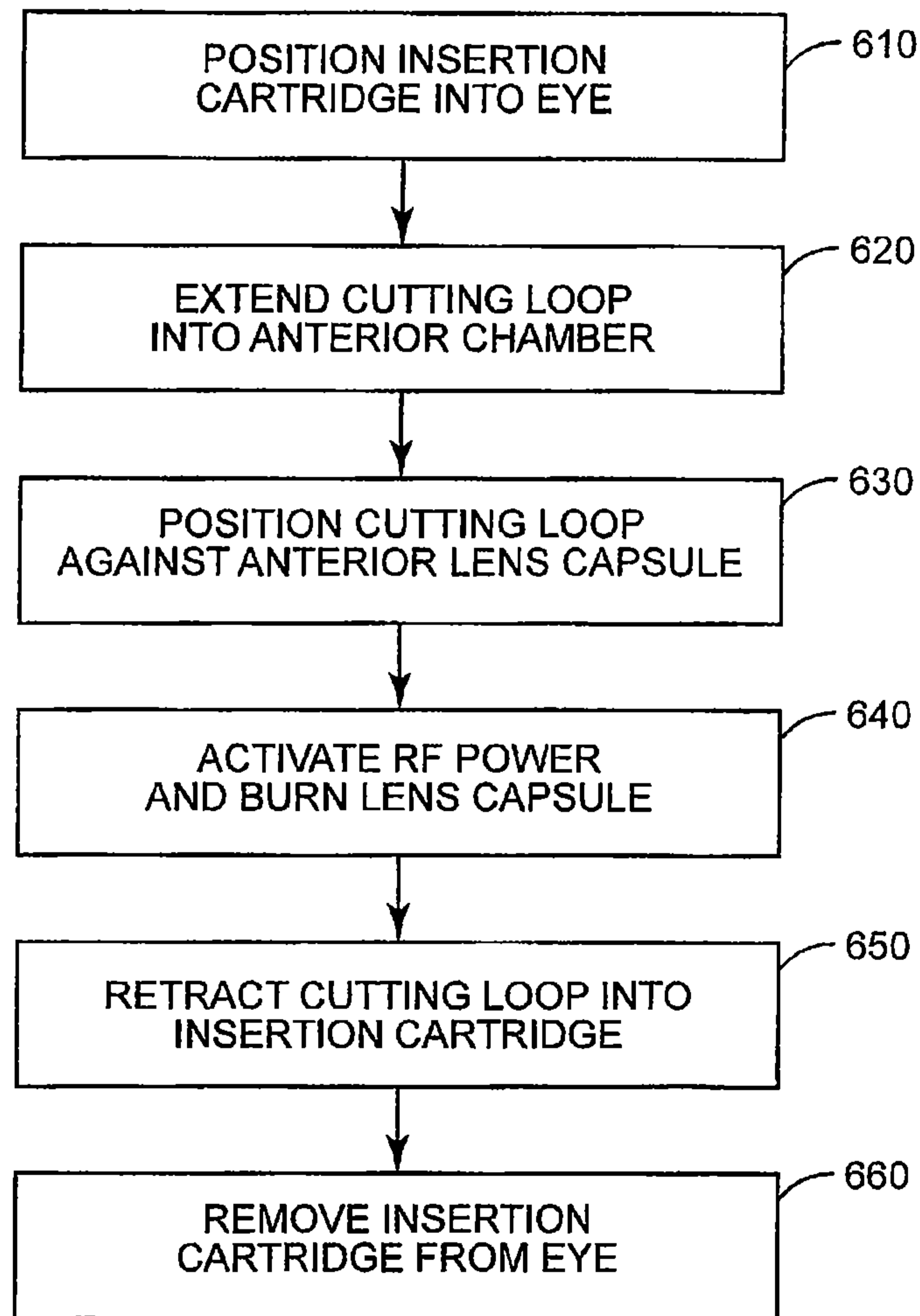
**FIG. 5B**



**FIG. 5C**



**FIG. 5D**

**FIG. 6**

