



- (51) **International Patent Classification:**
F01D 11/16 (2006.01) F02C 7/28 (2006.01)
F01D 11/20 (2006.01)
- (21) **International Application Number:**
PCT/US2014/032199
- (22) **International Filing Date:**
28 March 2014 (28.03.2014)
- (25) **Filing Language:** English
- (26) **Publication Language:** English
- (30) **Priority Data:**
61/806,248 28 March 2013 (28.03.2013) US
- (71) **Applicant: UNITED TECHNOLOGIES CORPORATION** [US/US]; 1 Financial Plaza, Hartford, CT 06101 (US).
- (72) **Inventor: POWELL, Brad;** 49 Pepperbush Lane, Guilford, CT 06437 (US).
- (74) **Agent: O'SHEA, Patrick, J.;** O'Shea Getz P.C. c/o CPA Global, P.O. Box 52050, Minneapolis, MN 55402 (US).
- (81) **Designated States** (unless otherwise indicated, for every kind of national protection available): AE, AG, AL, AM, AO, AT, AU, AZ, BA, BB, BG, BH, BN, BR, BW, BY,

BZ, CA, CH, CL, CN, CO, CR, CU, CZ, DE, DK, DM, DO, DZ, EC, EE, EG, ES, FI, GB, GD, GE, GH, GM, GT, HN, HR, HU, ID, IL, IN, IR, IS, JP, KE, KG, KN, KP, KR, KZ, LA, LC, LK, LR, LS, LT, LU, LY, MA, MD, ME, MG, MK, MN, MW, MX, MY, MZ, NA, NG, NI, NO, NZ, OM, PA, PE, PG, PH, PL, PT, QA, RO, RS, RU, RW, SA, SC, SD, SE, SG, SK, SL, SM, ST, SV, SY, TH, TJ, TM, TN, TR, TT, TZ, UA, UG, US, UZ, VC, VN, ZA, ZM, ZW.

- (84) **Designated States** (unless otherwise indicated, for every kind of regional protection available): ARIPO (BW, GH, GM, KE, LR, LS, MW, MZ, NA, RW, SD, SL, SZ, TZ, UG, ZM, ZW), Eurasian (AM, AZ, BY, KG, KZ, RU, TJ, TM), European (AL, AT, BE, BG, CH, CY, CZ, DE, DK, EE, ES, FI, FR, GB, GR, HR, HU, IE, IS, IT, LT, LU, LV, MC, MK, MT, NL, NO, PL, PT, RO, RS, SE, SI, SK, SM, TR), OAPI (BF, BJ, CF, CG, CI, CM, GA, GN, GQ, GW, KM, ML, MR, NE, SN, TD, TG).

Published:

- with international search report (Art. 21(3))
- before the expiration of the time limit for amending the claims and to be republished in the event of receipt of amendments (Rule 48.2(h))

(54) **Title:** MOVABLE AIR SEAL FOR GAS TURBINE ENGINE

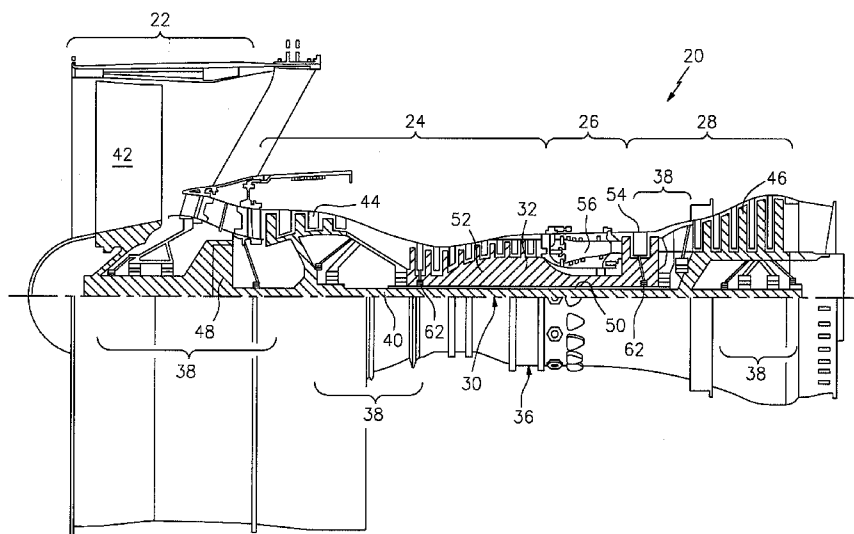

FIG. 1

(57) **Abstract:** A blade tip clearance control system for an engine case of a gas turbine engine according to one disclosed non-limiting embodiment of the present disclosure includes an air seal segment within the engine case. A drive link extends through the engine case, the drive link mounted to the air seal segment.



MOVABLE AIR SEAL FOR GAS TURBINE ENGINE

This application claims priority to U.S. Patent Appln. No. 61/806,248 filed March 28, 2013.

5

BACKGROUND

[0001] The present disclosure relates to a gas turbine engine and, more particularly, to a blade tip clearance control system therefor.

[0002] Gas turbine engines, such as those that power modern commercial and military aircraft, generally include a compressor to pressurize an airflow, a combustor for burning a hydrocarbon fuel in the presence of the pressurized air, and a turbine to extract energy from the resultant combustion gases.

[0003] The compressor and turbine sections include rotatable blade and stationary vane arrays. Within an engine case structure, the radial outermost tips of each blade array are positioned in close proximity to a shroud assembly. Outer air seals of the shroud assembly are located adjacent to the blade tips such that a radial tip clearance is defined therebetween.

[0004] During engine operation, the thermal environment in the engine varies and may cause thermal expansion or contraction. Such thermal expansion or contraction may not occur uniformly in magnitude or rate such that the radial tip clearance varies.

[0005] The radial tip clearance is typically designed so that the blade tips do not rub under high powered operations such as take-off when the blade disk and blades expand as a result of thermal expansion and centrifugal loads. When engine power is reduced to the cruise condition, the radial tip clearance increases.

[0006] To facilitate engine performance, at least some engines include a blade tip clearance control system to maintain a close radial tip clearance.

SUMMARY

[0007] A blade tip clearance control system for an engine case of a gas turbine engine according to one disclosed non-limiting embodiment of the present disclosure includes an air seal segment within the engine case. A drive link extends through the engine case, the drive link mounted to the air seal segment.

[0008] In a further embodiment of the present disclosure, the drive link is mounted to the air seal segment at multiple points.

[0009] In a further embodiment of any of the foregoing embodiments of the present disclosure, the drive link is mounted to the air seal segment with a multiple fasteners.

[0010] In a further embodiment of any of the foregoing embodiments of the present disclosure the drive link is mounted to the air through bosses in the engine case.

[0011] A further embodiment of any of the foregoing embodiments of the present disclosure further comprises a spring arrangement between the drive link and the engine case.

[0012] In a further embodiment of any of the foregoing embodiments of the present disclosure, the spring arrangement is at least partially located within a pocket in the drive link.

[0013] A further embodiment of any of the foregoing embodiments of the present disclosure includes a continuous band that surrounds the engine case and is retained to the drive link through an attachment bracket.

[0014] In a further embodiment of any of the foregoing embodiments of the present disclosure, the continuous band slides through the attachment bracket.

[0015] A further embodiment of any of the foregoing embodiments of the present disclosure includes a split band that surrounds the engine case and is retained to the drive link through an attachment bracket.

[0016] In a further embodiment of any of the foregoing embodiments of the present disclosure, the split band slides through the attachment bracket.

[0017] A further embodiment of any of the foregoing embodiments of the present disclosure includes a split band that surrounds the engine case and is retained to the drive link through an attachment bracket.

[0018] A further embodiment of any of the foregoing embodiments of the present disclosure includes a control tube that surrounds the engine case and is retained to the drive link through an attachment bracket.

[0019] A further embodiment of any of the foregoing embodiments of the present disclosure includes a fitting in communication with the control tube to receive a secondary airflow into the control tube.

[0020] A further embodiment of any of the foregoing embodiments of the present disclosure includes a heating element in communication with the control tube to receive a secondary airflow into the control tube.

[0021] A gas turbine engine according to another disclosed non-limiting embodiment of the present disclosure includes a multiple of air seal segments inside an engine case. A multiple of drive links mounted outside the engine case, each of the multiple of drive links mounted to one of the multiple of air seal segments.

[0022] In a further embodiment of any of the foregoing embodiments of the present disclosure, the multiple of drive links are passively actuated.

[0023] In a further embodiment of any of the foregoing embodiments of the present disclosure, the multiple of drive links are actively actuated.

5 [0024] A method for blade tip clearance control of a gas turbine engine, according to another disclosed non-limiting embodiment of the present disclosure includes providing a load transfer capability that converts loads on a drive link outside an engine case to a multiple of points on an air seal segment inside the engine case.

10 [0025] A further embodiment of any of the foregoing embodiments of the present disclosure includes passively providing the load transfer capability.

[0026] A further embodiment of any of the foregoing embodiments of the present disclosure includes actively providing the load transfer capability.

15 [0027] The foregoing features and elements may be combined in various combinations without exclusivity, unless expressly indicated otherwise. These features and elements as well as the operation of the invention will become more apparent in light of the following description and the accompanying drawings. It should be understood, however, the following description and drawings are intended to be exemplary in nature and non-limiting.

BRIEF DESCRIPTION OF THE DRAWINGS

20 [0028] Various features will become apparent to those skilled in the art from the following detailed description of the disclosed non-limiting embodiment. The drawings that accompany the detailed description can be briefly described as follows:

[0029] Figure 1 is a schematic cross-section of one example aero gas turbine engine;

[0030] Figure 2 is an is an enlarged partial sectional schematic view of a portion of a clearance control system according to one disclosed non-limiting embodiment;

5 [0031] Figure 3 is an enlarged partial sectional schematic view of a portion of a clearance control system and rotor therein;

[0032] Figure 4 is an enlarged partial sectional schematic view of one segment of the clearance control system;

10 [0033] Figure 5 is an enlarged partial sectional schematic view of a portion of the clearance control system;

[0034] Figure 6 is an enlarged partial sectional schematic view of a portion of a clearance control system according to another disclosed non-limiting embodiment;

[0035] Figure 7 is a schematic view of the clearance control system of Figure 6 in a first position;

15 [0036] Figure 8 is a partial sectional view of a clearance control system according to another disclosed non-limiting embodiment;

[0037] Figure 9 is an enlarged partial sectional schematic view of a portion of a clearance control system according to another disclosed non-limiting embodiment;

20 [0038] Figure 10 is an partial sectional schematic view of a portion of a clearance control system according to another disclosed non-limiting embodiment;

[0039] Figure 11 is an enlarged partial lateral sectional schematic view of the clearance control system of Figure 10;

[0040] Figure 12 is a partial sectional schematic view of a portion of a clearance control system according to another disclosed non-limiting embodiment; and

[0041] Figure 13 is a partial sectional schematic view of a portion of a clearance control system according to one disclosed non-limiting embodiment.

5

DETAILED DESCRIPTION

[0042] Figure 1 schematically illustrates a gas turbine engine 20. The gas turbine engine 20 is disclosed herein as a two-spool turbo fan that generally incorporates a fan section 22, a compressor section 24, a combustor section 26 and a turbine section 28. Alternative engines might include an augmentor section (not shown) among other systems or features. The fan section 22 drives air along a bypass flowpath while the compressor section 24 drives air along a core flowpath for compression and communication into the combustor section 26 then expansion through the turbine section 28. Although depicted as a turbofan in the disclosed non-limiting embodiment, it should be appreciated that the concepts described herein are not limited to use with turbofans as the teachings may be applied to other types of turbine engines such as a turbojets, turboshafts, industrial gas turbines, and three-spool (plus fan) turbofans wherein an intermediate spool includes an intermediate pressure compressor ("IPC") between a Low Pressure Compressor ("LPC") and a High Pressure Compressor ("HPC"), and an intermediate pressure turbine ("IPT") between the high pressure turbine ("HPT") and the Low pressure Turbine ("LPT").

10
15
20

[0043] The engine 20 generally includes a low spool 30 and a high spool 32 mounted for rotation about an engine central longitudinal axis A relative to an engine static

structure 36 via several bearing structures 38. The low spool 30 generally includes an inner shaft 40 that interconnects a fan 42, a low pressure compressor 44 (“LPC”) and a low pressure turbine 46 (“LPT”). The inner shaft 40 drives the fan 42 directly or through a geared architecture 48 to drive the fan 42 at a lower speed than the low spool 30. An exemplary
5 reduction transmission is an epicyclic transmission, namely a planetary or star gear system.

[0044] The high spool 32 includes an outer shaft 50 that interconnects a high pressure compressor 52 (“HPC”) and high pressure turbine 54 (“HPT”). A combustor 56 is arranged between the high pressure compressor 52 and the high pressure turbine 54. The inner shaft 40 and the outer shaft 50 are concentric and rotate about the engine central longitudinal
10 axis “A” which is collinear with their longitudinal axes.

[0045] Core airflow is compressed by the LPC 44 then the HPC 52, mixed with the fuel and burned in the combustor 56, then expanded over the HPT 54 and the LPT 46. The turbines 54, 46 rotationally drive the respective low spool 30 and high spool 32 in response to the expansion. The main engine shafts 40, 50 are supported at a plurality of points by bearing
15 structures 38 within the static structure 36. It should be appreciated that various bearing structures 38 at various locations may alternatively or additionally be provided.

[0046] In one non-limiting example, the gas turbine engine 20 is a high-bypass geared aircraft engine. In a further example, the gas turbine engine 20 bypass ratio is greater than about six (6:1). The geared architecture 48 can include an epicyclic gear train, such as a
20 planetary gear system or other gear system. The example epicyclic gear train has a gear reduction ratio of greater than about 2.3, and in another example is greater than about 2.5:1. The geared turbofan enables operation of the low spool 30 at higher speeds which can increase

the operational efficiency of the low pressure compressor 44 and low pressure turbine 46 and render increased pressure in a fewer number of stages.

[0047] A pressure ratio associated with the low pressure turbine 46 is pressure measured prior to the inlet of the low pressure turbine 46 as related to the pressure at the outlet of the low pressure turbine 46 prior to an exhaust nozzle of the gas turbine engine 20. In one non-limiting embodiment, the bypass ratio of the gas turbine engine 20 is greater than about ten (10:1), the fan diameter is significantly larger than that of the low pressure compressor 44, and the low pressure turbine 46 has a pressure ratio that is greater than about five (5:1). It should be appreciated, however, that the above parameters are only exemplary of one embodiment of a geared architecture engine and that the present disclosure is applicable to other gas turbine engines including direct drive turbofans.

[0048] In one embodiment, a significant amount of thrust is provided by the bypass flow path due to the high bypass ratio. The fan section 22 of the gas turbine engine 20 is designed for a particular flight condition - typically cruise at about 0.8 Mach and about 35,000 feet. This flight condition, with the gas turbine engine 20 at its best fuel consumption, is also known as bucket cruise Thrust Specific Fuel Consumption (TSFC). TSFC is an industry standard parameter of fuel consumption per unit of thrust.

[0049] Fan Pressure Ratio is the pressure ratio across a blade of the fan section 22 without the use of a Fan Exit Guide Vane system. The low Fan Pressure Ratio according to one non-limiting embodiment of the example gas turbine engine 20 is less than 1.45. Low Corrected Fan Tip Speed is the actual fan tip speed divided by an industry standard temperature correction of $(\text{"T"} / 518.7)^{0.5}$ in which "T" represents the ambient temperature in

degrees Rankine. The Low Corrected Fan Tip Speed according to one non-limiting embodiment of the example gas turbine engine 20 is less than about 1150 fps (351 m/s).

[0050] With reference to Figure 2, a blade tip clearance control system 58 includes a movable air seal system 60 that operates to control blade clearances inside a compressor section 24 and/or turbine section 28 (Figure 3). The movable air seal system 60 may be arranged around each or particular stages within the gas turbine engine 20. That is, each rotor stage may have an associated movable air seal system 60 of the blade tip clearance control system 58.

[0051] Each movable air seal system 60 may be subdivided into a multiple of segments 62, each with a respective air seal segment 64, a drive link 66 and a spring arrangement 68. It should be appreciated that various other components may alternatively or additionally be provided.

[0052] With reference to Figure 4, each respective air seal segment 64 in one disclosed non-limiting embodiment extends about thirty-six (36) degrees within a slot 70 of an engine case 72.—It should be appreciated that any number of segments may be utilized wherein the segment angle is approximately $360^\circ / n$, where “n” is the number of segments. Each air seal segment 64 may be manufactured of a metal body with an abradable material on the inner radial surface, and include a groove 74 on one lateral edge 76 and a tab 78 on the other lateral edge 80 such that the array of the arcuate air seal segments 64 may expand and contract, yet maintain an air seal there between. That is, the array of the arcuate air seal segments 64 is movable to define an air seal of variable effective diameter. (i.e. “effective” in the sense that outward radial movement of the segments produces a slightly non-circular profile)

[0053] With reference to Figure 2, each air seal segment 64 mates up rigidly to a respective drive link 66 by two guide studs 86 on the drive link 66. The guide studs 86 pass through respective holes in the bosses 84 of the engine case 72. Fasteners 82 pass through holes in the guide studs 86 of the drive link 66 to mate with respective threads in the air seal segment 64. The air seal segment 64 is thereby rigidly connected to the drive link 66 at the two locations where the guide studs 86 mate up with the air seal segment 64. The axes of the guide studs 86 and the holes in the bosses 84 are all parallel so as to allow radial inward and outward movement of each air segment 64 in tandem with the drive link 66. It should be appreciated that more than two parallel guide studs 86 and bosses 84 may be used to provide an even greater degree of support of the air seal segment 64. Seals may additionally be located, for example, between the bosses 84 and guide studs 86 to prevent airflow there through to both thermally and aerodynamically isolate the drive link 66 outside the case 72.

[0054] With continued reference to Figure 2, the spring arrangement 68 may be located within pockets 88 in each drive link 66 (Figure 4) to react against an outer surface 90 of the engine case 72. The spring arrangement 68 biases the respective air seal segment 64 outward with respect to the engine central longitudinal axis A. That is, the spring arrangement 68 permits a unidirectional load actuation technique wherein the return stroke is by spring action. Each drive link 66 may alternatively be used without spring arrangement 68 in cases where the load actuation technique provides two-way load transfer. Although coil springs are illustrated in the disclosed non-limiting embodiment, it should be appreciated that various bias members may alternatively or additionally be provided as the spring arrangement 68, e.g., wave springs, leaf springs, Belleville washers, etc.

[0055] With continued reference to Figure 2, each drive link 66 is located on the outer surface 90 of the engine case 72 and is thereby fully isolated from conditions inside the compressor and/or turbine section, i.e. no thermal or aerodynamic interactions. Each drive link 66 operates to provide a load transfer capability that converts radial loads at a single point on the drive link 66 to multiple parallel points on the air seal segment 64. That is, the drive link 66 connects rigidly to the air seal segment 64 at two or more parallel locations via the fasteners 82, bosses 84 and guide studs 86 that provide mechanical support for the respective drive link 66 and air seal segment 64 set.

[0056] With reference to Figure 5, in one disclosed non-limiting embodiment, the blade tip clearance control system 58 further includes an actuator 92 that operates in response to a control 94. It should be appreciated that various other components such as sensors, actuators and other subsystems may be utilized herewith.

[0057] The control 94 generally includes a control module that executes seal movement logic. The control module typically includes a processor, a memory, and an interface. The processor may be any type of known microprocessor having desired performance characteristics. The memory may be any computer readable medium which stores data and control algorithms such as logic as described herein. The interface facilitates communication with other components such as a capacitive sensor or other gap sensor, and the actuator 92. The functions of the logic are disclosed in terms of functional block diagrams, and it should be understood by those skilled in the art with the benefit of this disclosure that these functions may be enacted in either dedicated hardware circuitry or programmed software routines capable of execution in a microprocessor based electronics control embodiment. In

one non-limiting embodiment, the control module may be a portion of a flight control computer, a portion of a Full Authority Digital Engine Control (FADEC), a stand-alone unit or other system.

[0058] The actuator 92 may include a mechanical, electrical, hydraulic and/or
5 pneumatic drive that operates to contract and expand the movable air seal system 60 in response to a control 94. That is, the actuator 92 may include various positionable members.

[0059] In one disclosed non-limiting embodiment, the actuator 92 is coupled to a continuous band 96 that surrounds the drive links 66 and is retained to each by an attachment bracket 98. The attachment bracket 98 may be generally rectilinear to receive the continuous
10 band 96 therethrough. That is, the attachment bracket 98 permits the continuous band 96 to slide therethrough. The continuous band 96 is, for example, a flexible metal belt that may be selectively fixed to move each drive link 66. It should be appreciated that may alternatively include a series of smaller belts or members hinged at one or more locations.

[0060] With reference to Figure 6, one or more linear drive inputs 100 are
15 selectively driven by the actuator 92 to place the continuous band 96 in tension and thereby compress the drive links 66. That is, the linear drive inputs 100 are driven toward the engine central longitudinal axis A to flex the continuous band 96 to eliminate slack, overcome the spring arrangement 68 and compress the drive links 66 to contract the array of air seal segments 64 (Figure 7). The array of air seal segments 64 thereby provides a smaller inner
20 diameter to reduce the radial tip clearance relative to the rotating blade tips. Release of the linear drive input 100 or extension away from the engine central longitudinal axis A permits the spring arrangement 68 to extend the drive links 66 and expand the array of air seal

segments 64. The array of air seal segments 64 thereby provides a larger effective inner diameter to increase the radial tip clearance relative to the rotating blade tips.

[0061] With reference to Figure 8, in another disclosed non-limiting embodiment, the actuator 92 is coupled to multiple continuous bands 96 to actuate multiple stages
5 simultaneously. It should be appreciated that multiple actuators 92 may additionally be provided.

[0062] With reference to Figure 9, in another disclosed non-limited embodiment, a split band 102 which is retained similarly to the continuous band by attachment brackets 98
10 may be driven to tension by an actuator 92 which applies load in a tangential manner at attachment points 104 and 106.

[0063] With reference to Figure 10, in another disclosed non-limiting embodiment, a control tube 110 surrounds the drive links 66 and is retained to each by an attachment bracket
15 112. The control tube 110 may be rectilinear in cross-section and manufactured of a metallic or non-metallic alloy (Figure 11). It should be appreciated that various shapes may alternatively be provided.

[0064] The control tube 110 expands and contracts as a function of the local ambient temperature around the engine case 72. As a practical matter, the control tube 110 is
20 isolated, both thermally and aerodynamically, from the conditions inside the compressor section 24 and/or turbine section 28. By material selection of the control tube 110, passive clearance control operations utilize the temperature differential inside and outside the control tube 110 to expand and contract the array of air seal segments 64 to thereby control the radial tip clearance relative the rotating blade tips.

[0065] With reference to Figure 11, mechanical stops 114 (illustrated schematically) may interact with the array of air seal segments 64 and/or the drive links 66 so as to precisely index the expansion and contraction. In this manner, local temperature conditions around the engine case are harnessed to passively control blade clearances. For an example 18" (457mm) compressor, the typical radial displacement of the array of air seal segments 64 is about 0.015" (15 mils; 0.38mm). The array of air seal segments 64 are precisely movable between the mechanical stops 114 which can be set to a predetermined distance, for example, 0.010" (10 mils; 0.25mm) for a relatively small compressors and 0.040" (40 mils; 1mm) for a relatively large compressor. The displacement gap is, at least partially, a function of the engine core size and the dynamic conditions of a particular application.

[0066] With reference to Figure 12, in another disclosed non-limiting embodiment, a control tube 116 may include a fitting 118 that receives a secondary airflow from upstream, downstream and/or ambient air sources 120. By control of the temperature of air, and the injection and release of the air from the control tube 116, active clearance control operations that utilize the temperature differential inside and outside the control tube 116 varies the radial tip clearance. It should be appreciated that fluids other than air may alternatively be utilized. The fluid may be exhausted at an exit fitting, or by one or more exit holes in the control tube 116.

[0067] With reference to Figure 13, in another disclosed non-limiting embodiment, a control tube 122 may be exposed one or more to embedded heating elements 124 which selectively heat the control tube 122 to expand the control tube 122 when the heating element 124 is energized via power input pins 126. When the heating element is de-energized the

control tube 122 contracts and thereby controls radial tip clearance. The control tube 122 may alternatively or additionally include fittings for various fluids and/or be manufactured of various thermally or electrically variable materials.

5 [0068] The movable air seal system 60 provides thermal and aerodynamic isolation from the engine interior; converts radial movement to parallel motion at two or more points on each segment of the air seal; is fully scalable to larger or small engine cores; and numerous actuation techniques may be utilized.

10 [0069] The use of the terms "a" and "an" and "the" and similar references in the context of description (especially in the context of the following claims) are to be construed to cover both the singular and the plural, unless otherwise indicated herein or specifically contradicted by context. The modifier "about" used in connection with a quantity is inclusive of the stated value and has the meaning dictated by the context (e.g., it includes the degree of error associated with measurement of the particular quantity). All ranges disclosed herein are inclusive of the endpoints, and the endpoints are independently combinable with each other. It should be appreciated that relative positional terms such as "forward," "aft," "upper," "lower," "above," "below," and the like are with reference to the normal operational attitude of the vehicle and should not be considered otherwise limiting.

20 [0070] Although the different non-limiting embodiments have specific illustrated components, the embodiments of this invention are not limited to those particular combinations. It is possible to use some of the components or features from any of the non-limiting embodiments in combination with features or components from any of the other non-limiting embodiments.

[0071] It should be appreciated that like reference numerals identify corresponding or similar elements throughout the several drawings. It should also be appreciated that although a particular component arrangement is disclosed in the illustrated embodiment, other arrangements will benefit herefrom.

5 [0072] The foregoing description is exemplary rather than defined by the limitations within. Various non-limiting embodiments are disclosed herein, however, one of ordinary skill in the art would recognize that various modifications and variations in light of the above teachings will fall within the scope of the appended claims. It is therefore to be appreciated that within the scope of the appended claims, the disclosure may be practiced other
10 than as specifically described. For that reason the appended claims should be studied to determine true scope and content.

CLAIMS

What is claimed is:

1. A blade tip clearance control system for an engine case of a gas turbine engine
5 comprising:
an air seal segment within the engine case; and
a drive link that extends through the engine case, said drive link mounted to said air seal
segment.
- 10 2. The blade tip clearance control system as recited in claim 1, wherein said drive
link is mounted to said air seal segment at multiple points.
3. The blade tip clearance control system as recited in claim 1, wherein said drive
link is mounted to said air seal segment with a multiple fasteners.
- 15 4. The blade tip clearance control system as recited in claim 1, wherein said drive
link is mounted to said air through bosses in the engine case.
5. The blade tip clearance control system as recited in claim 1, further comprising
20 spring arrangement between said drive link and the engine case.

6. The blade tip clearance control system as recited in claim 5, wherein said spring arrangement is at least partially located within a pocket in said drive link.

7. The blade tip clearance control system as recited in claim 1, further comprising a
5 continuous band that surrounds the engine case and is retained to the drive link through an attachment bracket.

8. The blade tip clearance control system as recited in claim 7, wherein said continuous band slides through said attachment bracket.

10

9. The blade tip clearance control system as recited in claim 1, further comprising a split band that surrounds the engine case and is retained to the drive link through an attachment bracket.

15

10. The blade tip clearance control system as recited in claim 9, wherein said split band slides through said attachment bracket.

20

11. The blade tip clearance control system as recited in claim 1, further comprising a split band that surrounds the engine case and is retained to the drive link through an attachment bracket.

12. The blade tip clearance control system as recited in claim 1, further comprising a control tube that surrounds the engine case and is retained to the drive link through an attachment bracket.

5 13. The blade tip clearance control system as recited in claim 12, further comprising a fitting in communication with said control tube to receive a secondary airflow into said control tube.

10 14. The blade tip clearance control system as recited in claim 12, further comprising a heating element in communication with said control tube to receive a secondary airflow into said control tube.

15. A gas turbine engine comprising:

an engine case;

15 a multiple of air seal segments inside said engine case; and

a multiple of drive links mounted outside said engine case, each of said multiple of drive links mounted to one of said multiple of air seal segments.

20 16. The blade tip clearance control system as recited in claim 15, wherein said multiple of drive links are passively actuated.

17. The blade tip clearance control system as recited in claim 15, wherein said multiple of drive links are actively actuated.

5 18. A method for blade tip clearance control of a gas turbine engine, comprising:
providing a load transfer capability that converts loads on a drive link outside an engine case to a multiple of points on an air seal segment inside the engine case.

10 19. The method as recited in claim 18, further comprising:
passively providing the load transfer capability.

20. The method as recited in claim 18, further comprising:
actively providing the load transfer capability.

15

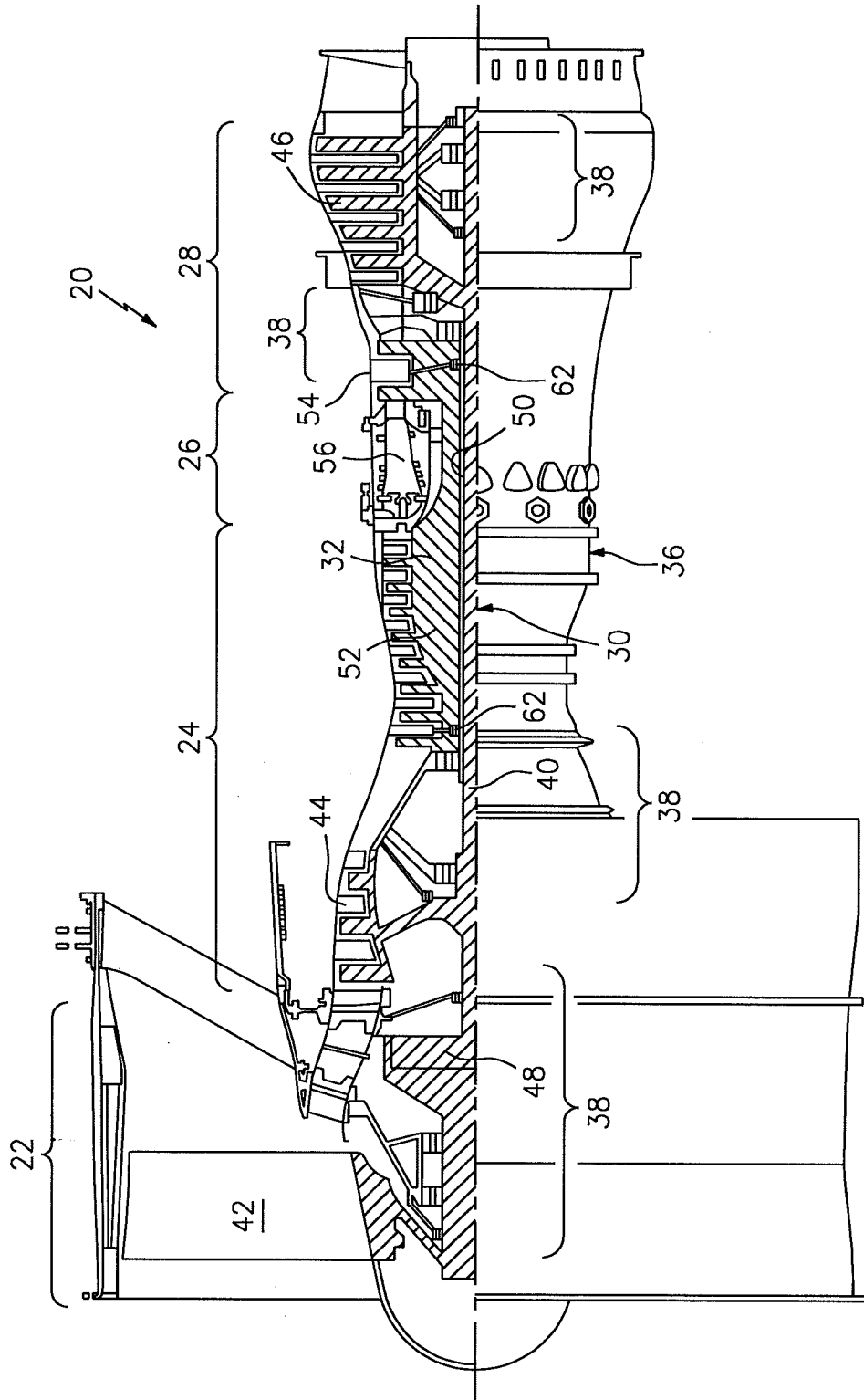

FIG. 1

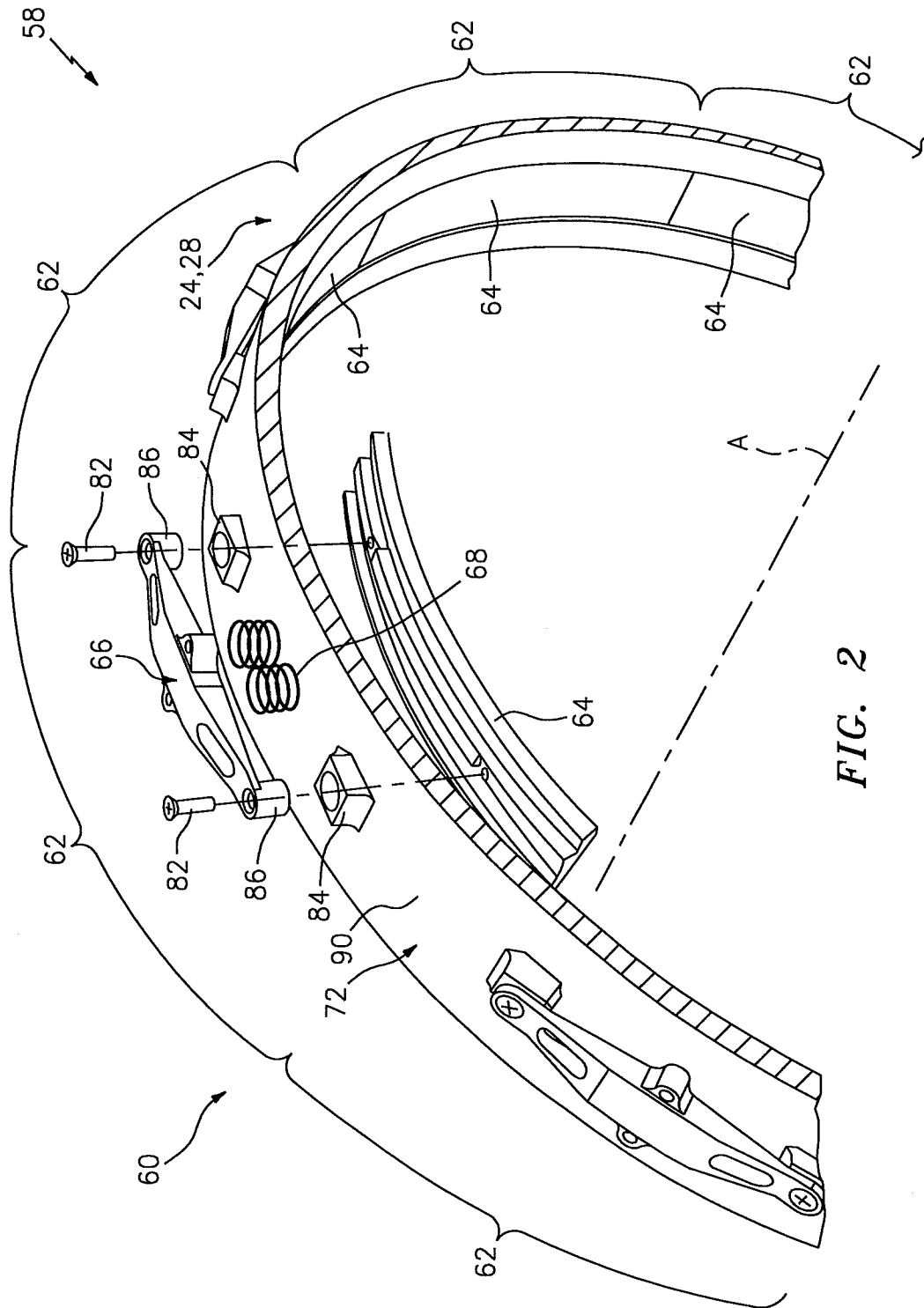

FIG. 2

3/13

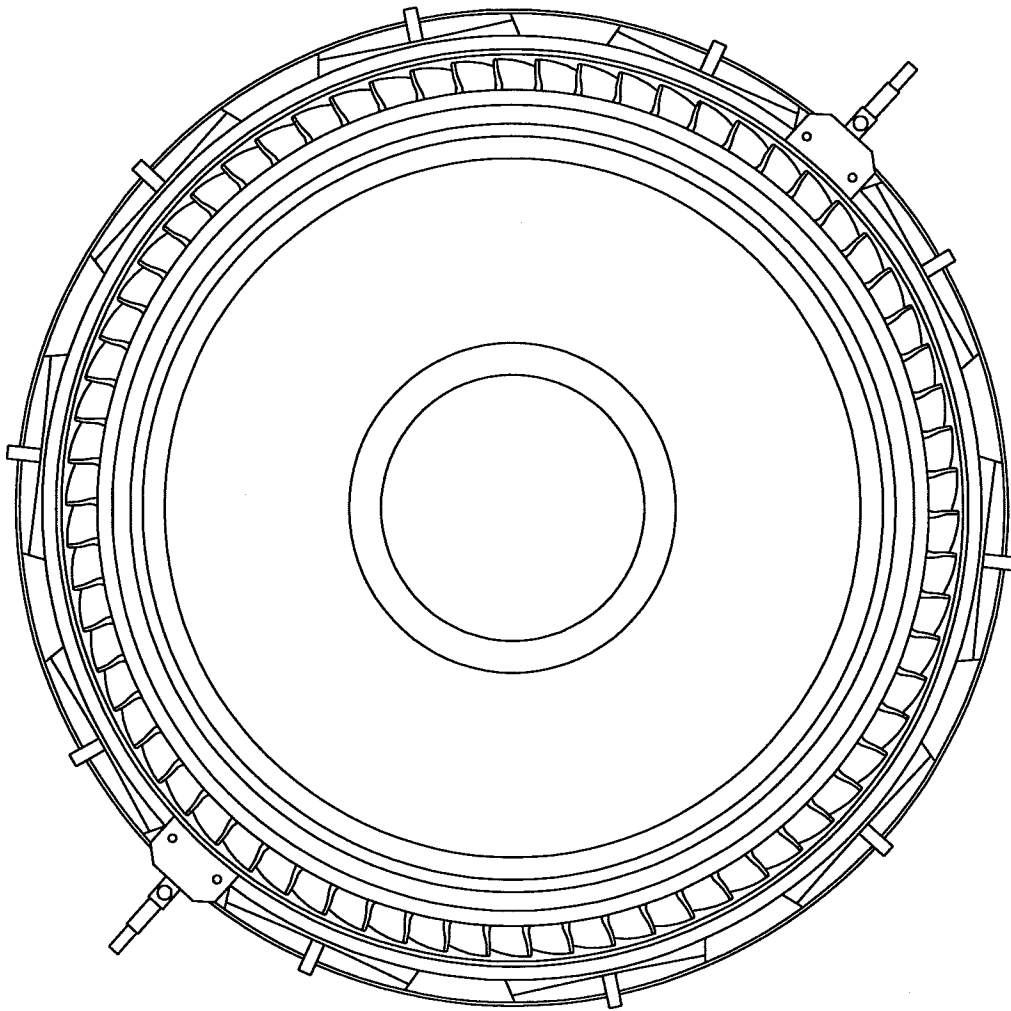

FIG. 3

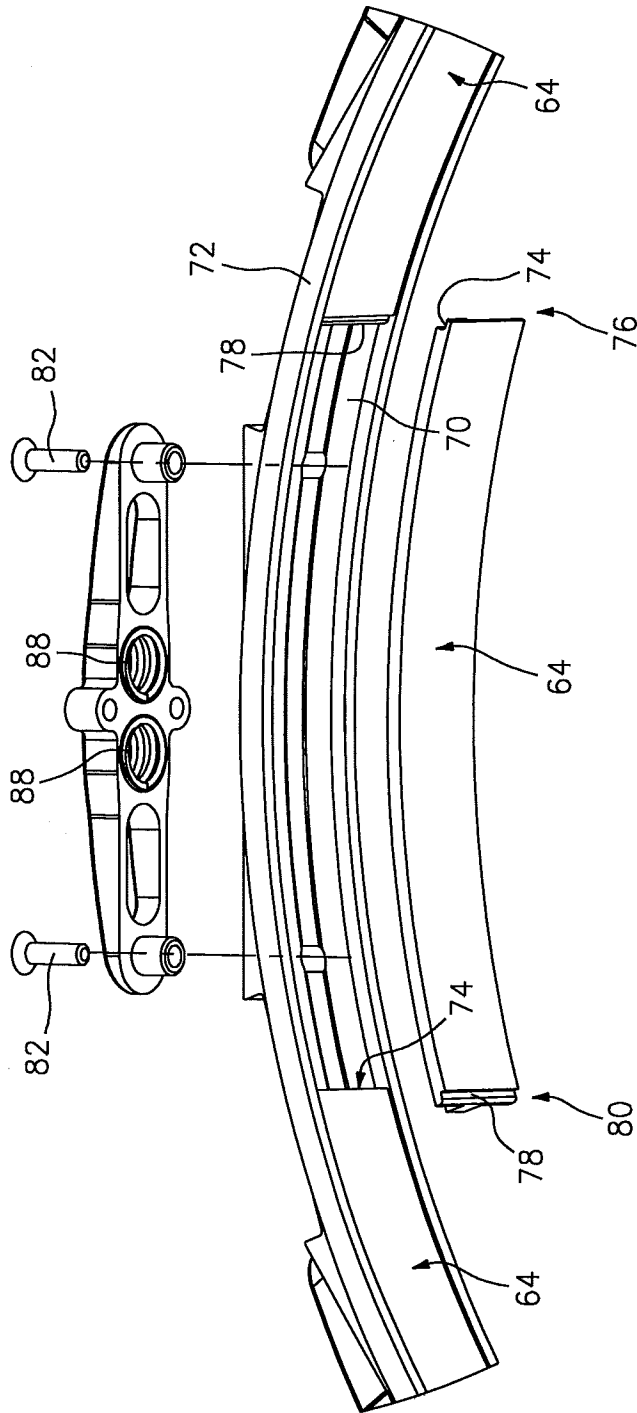

FIG. 4

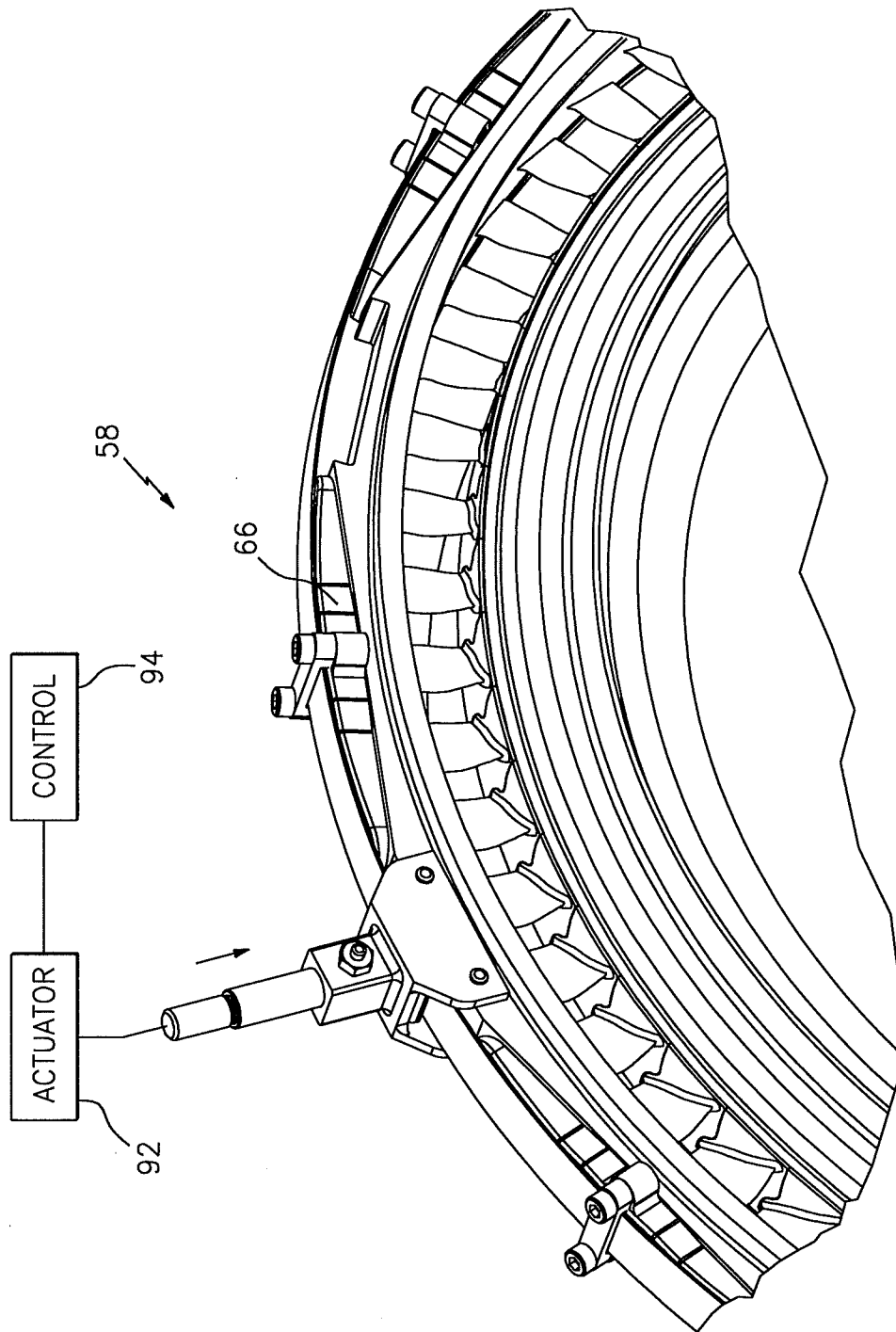

FIG. 5

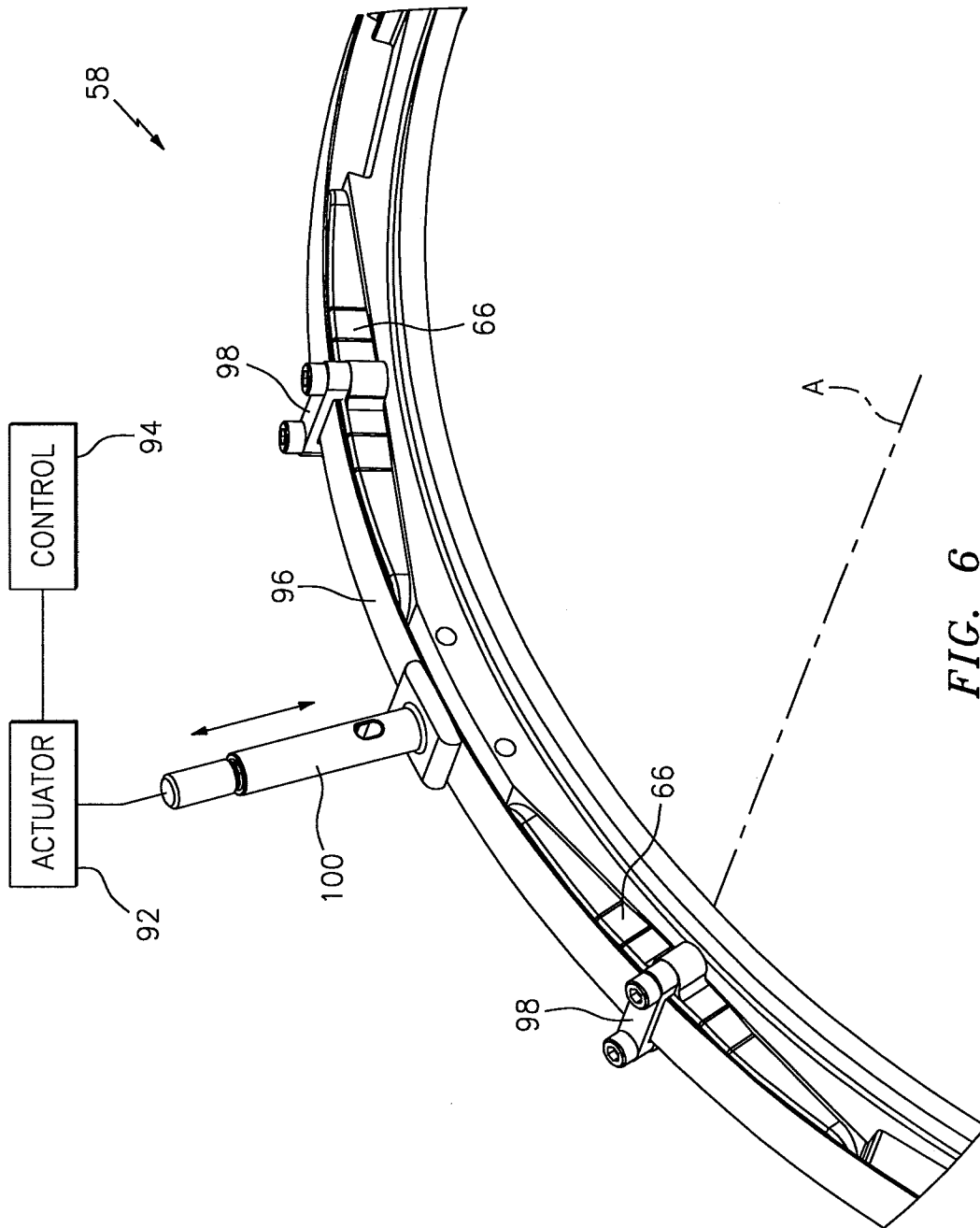

FIG. 6

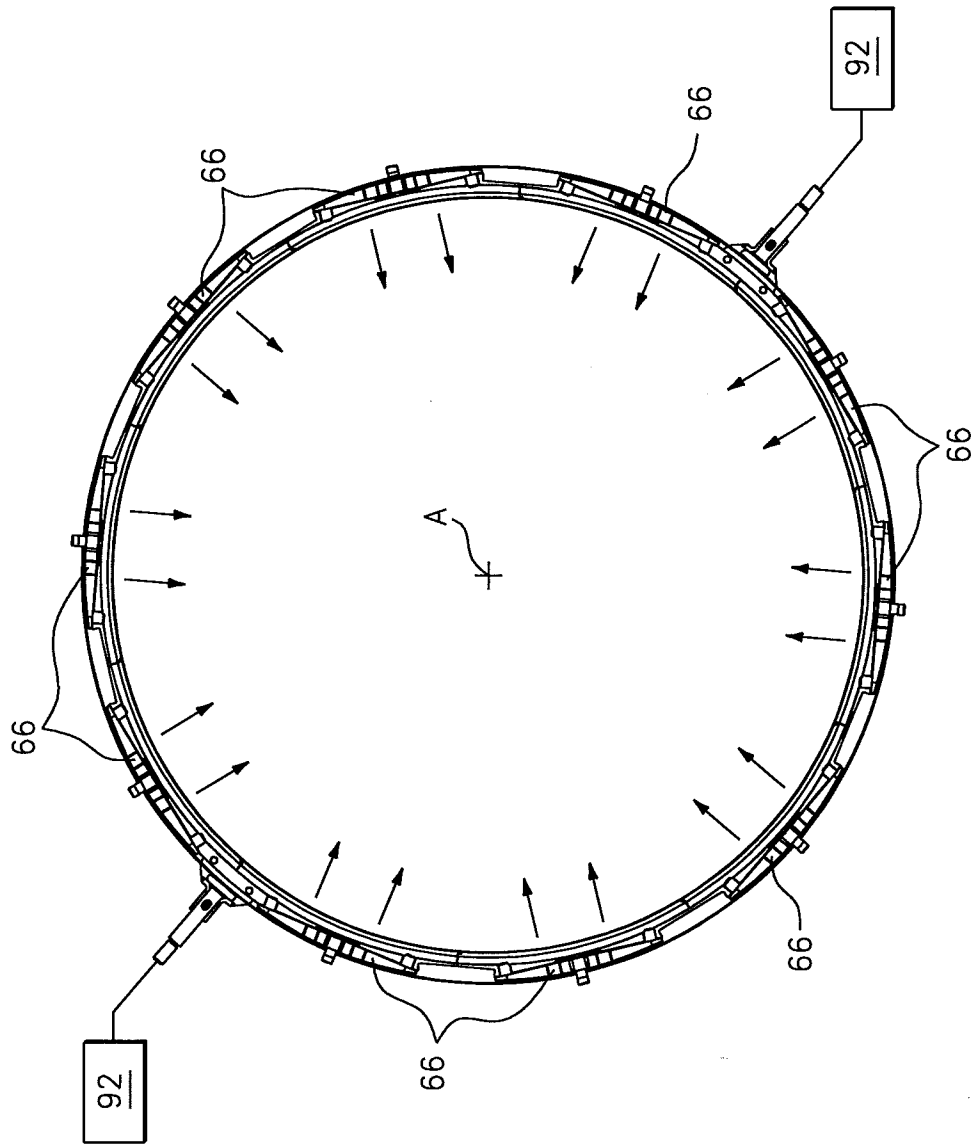

FIG. 7

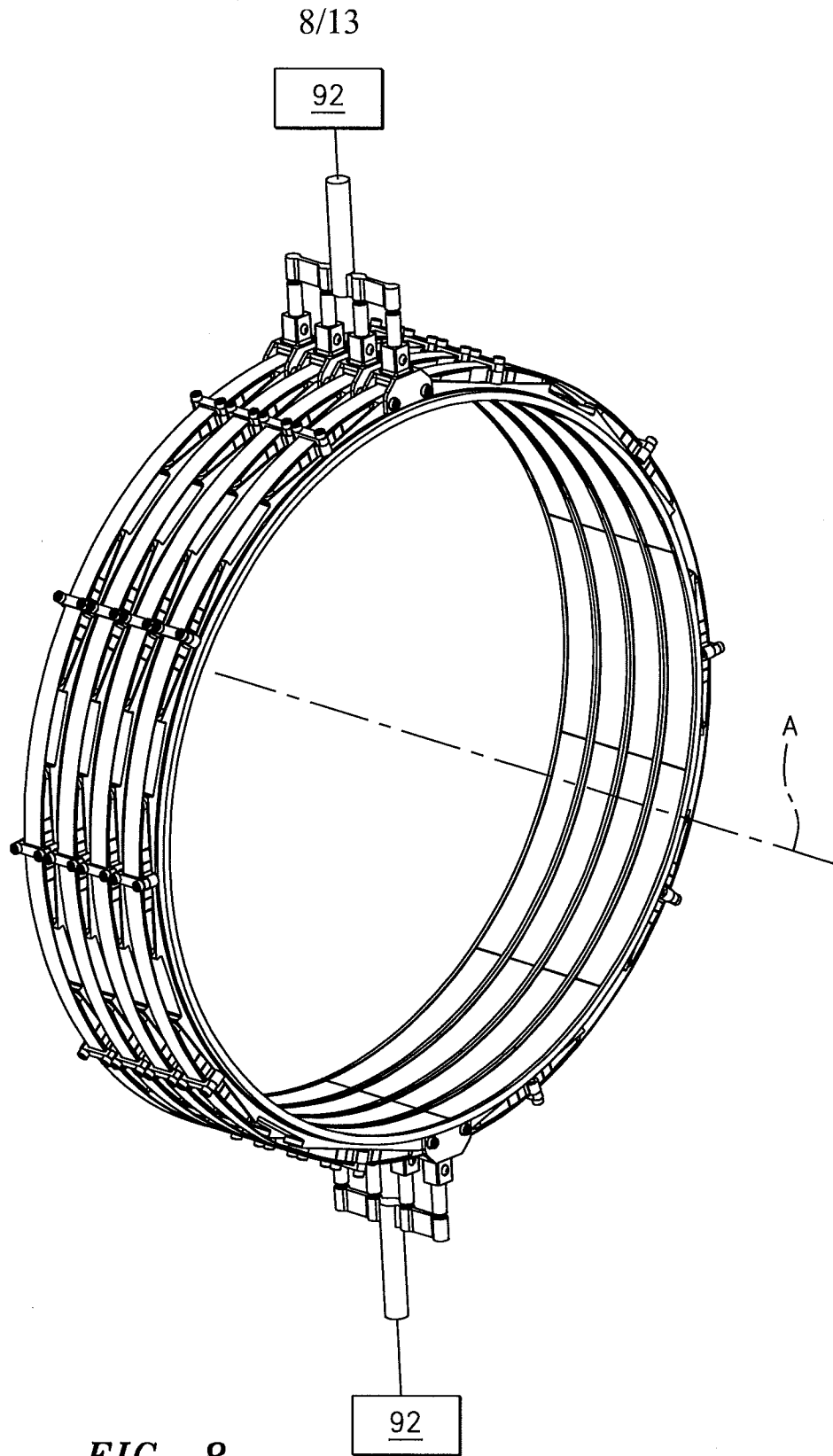

FIG. 8

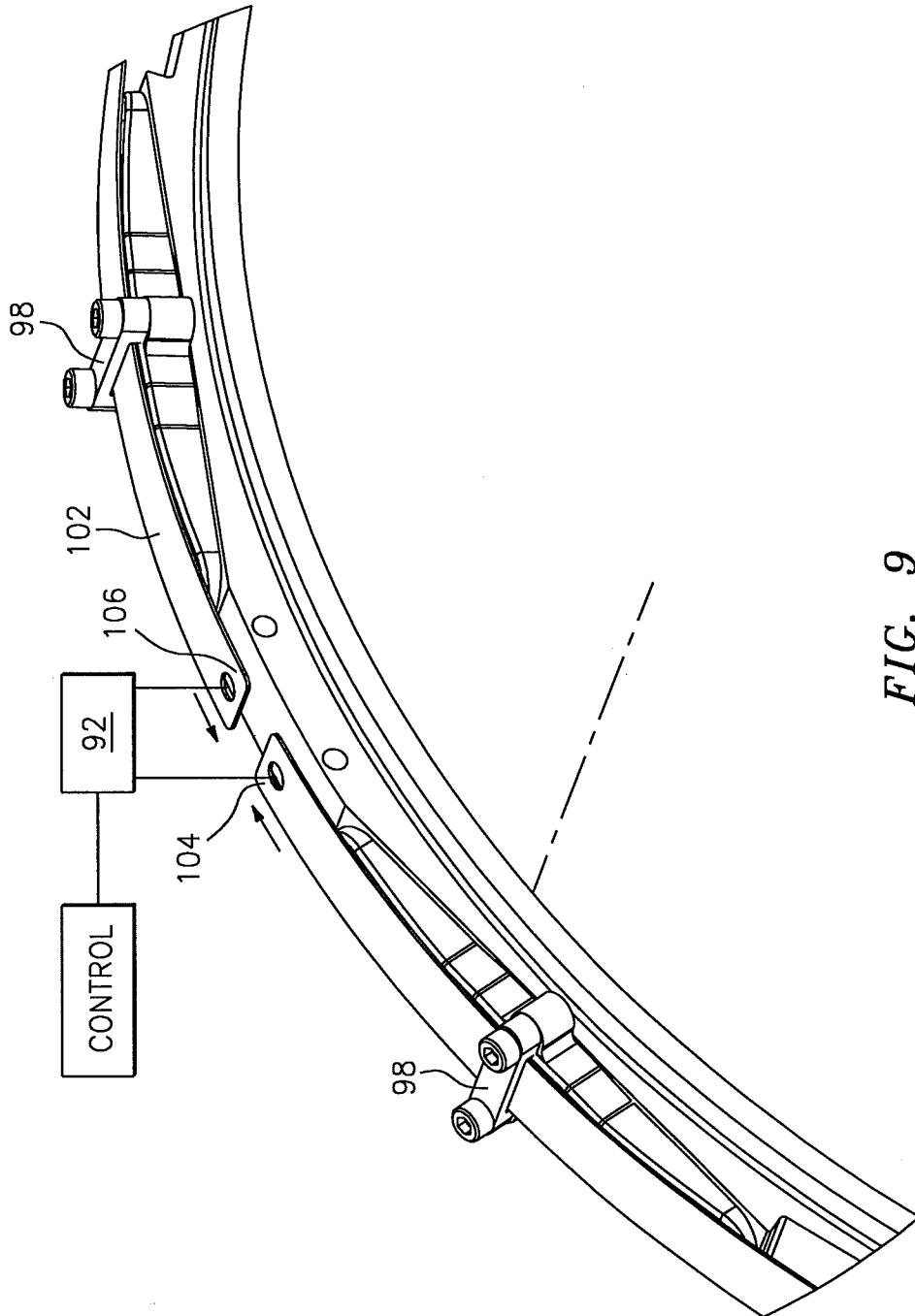

FIG. 9

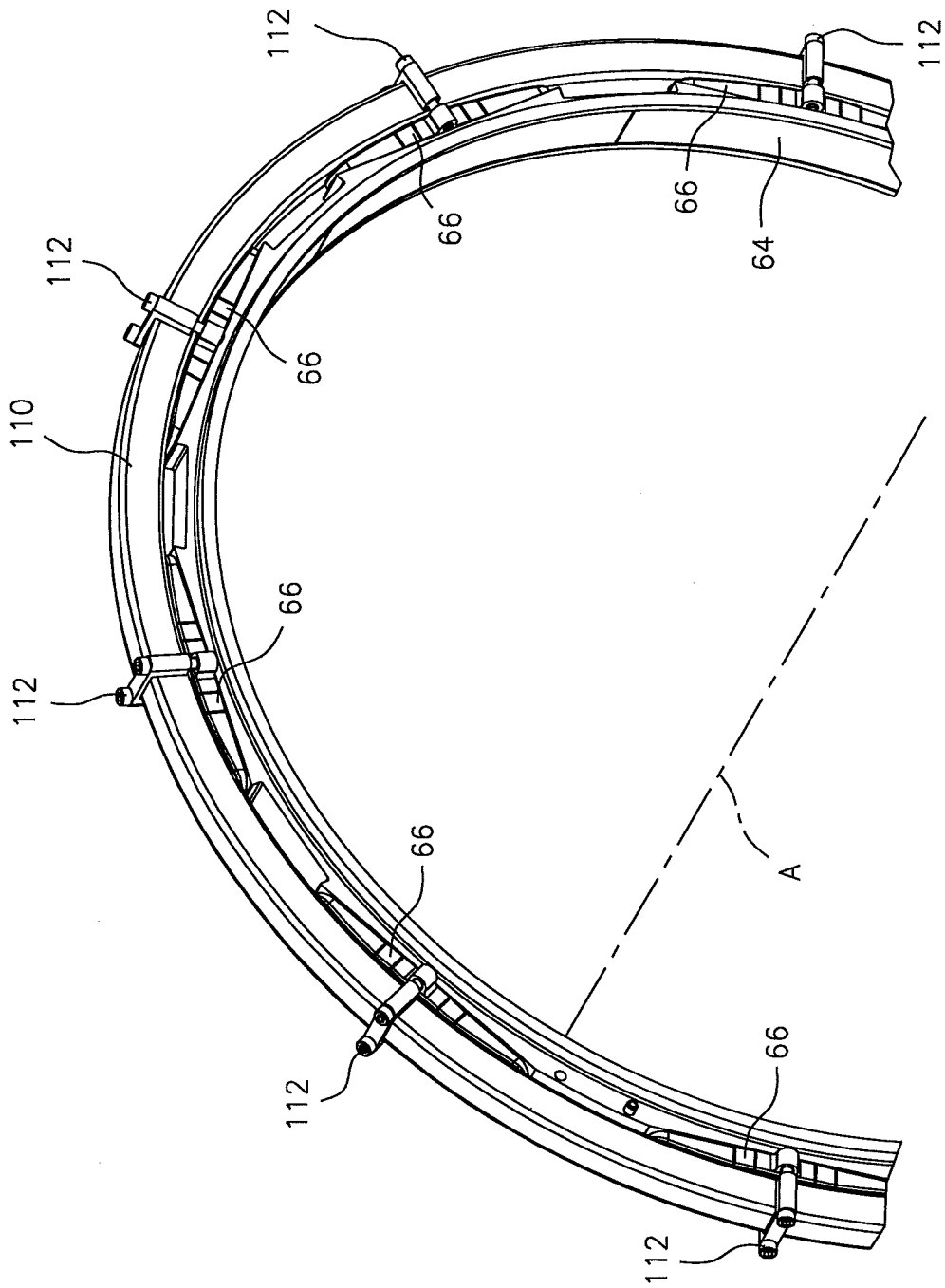

FIG. 10

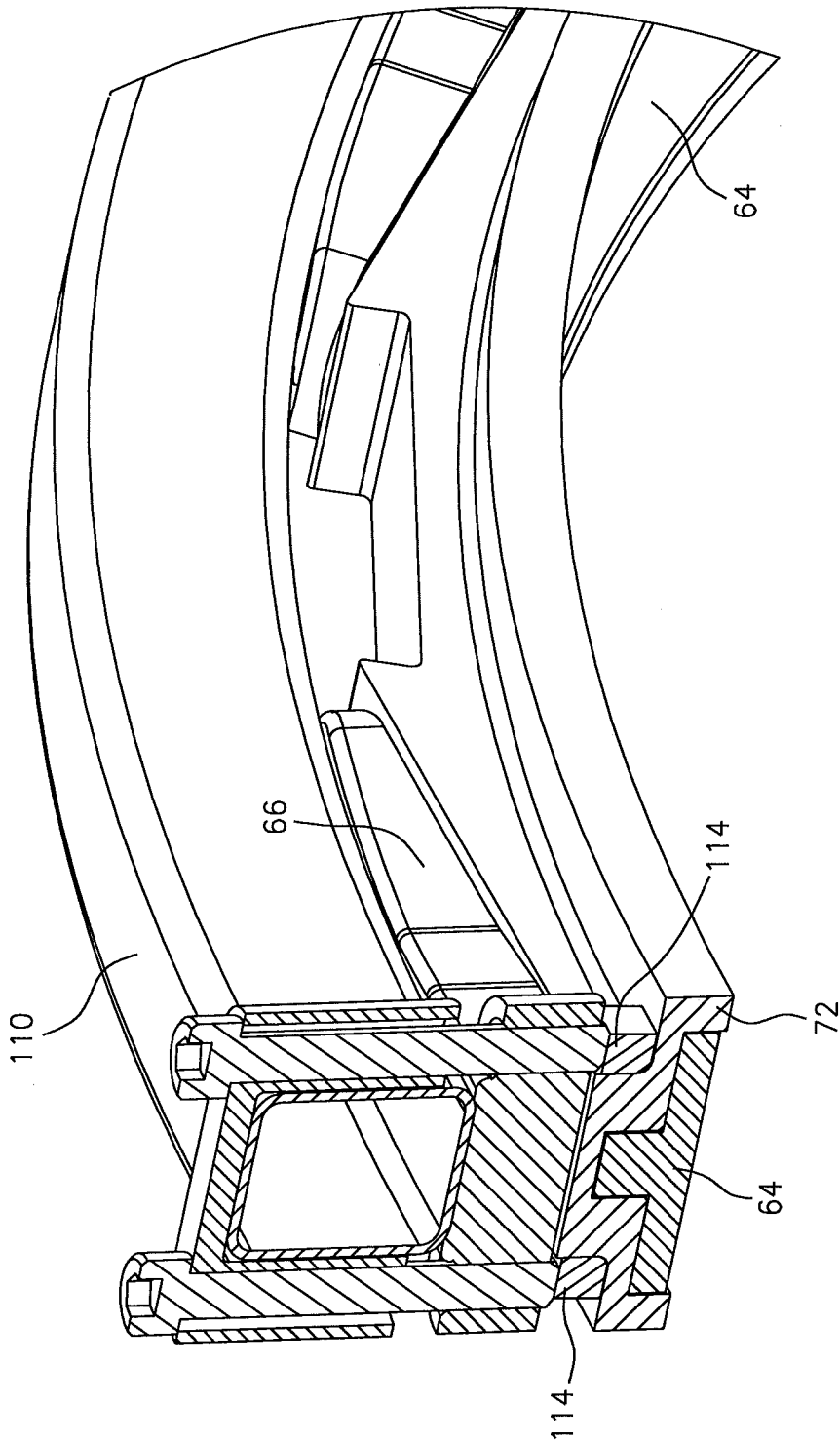

FIG. 11

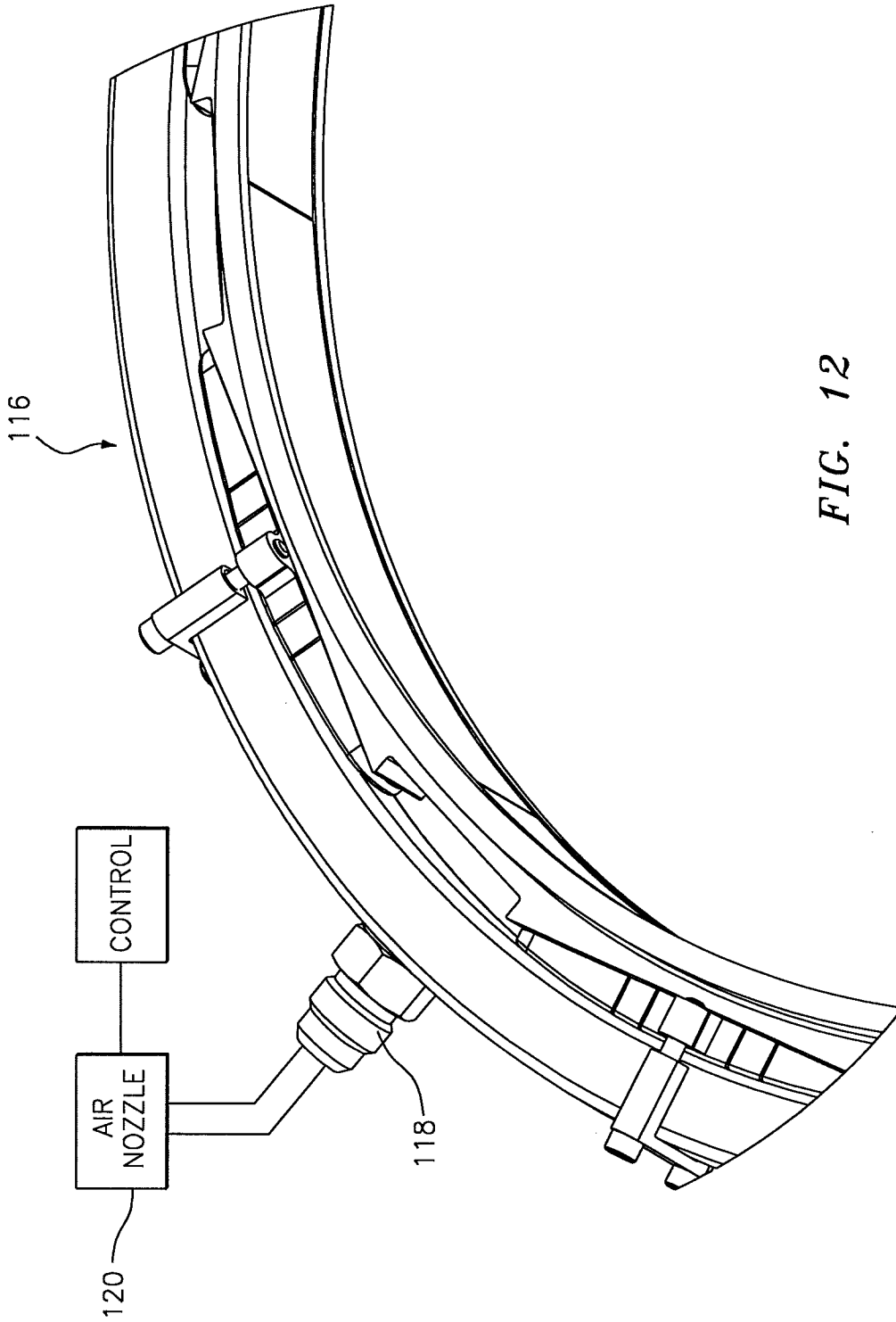

FIG. 12

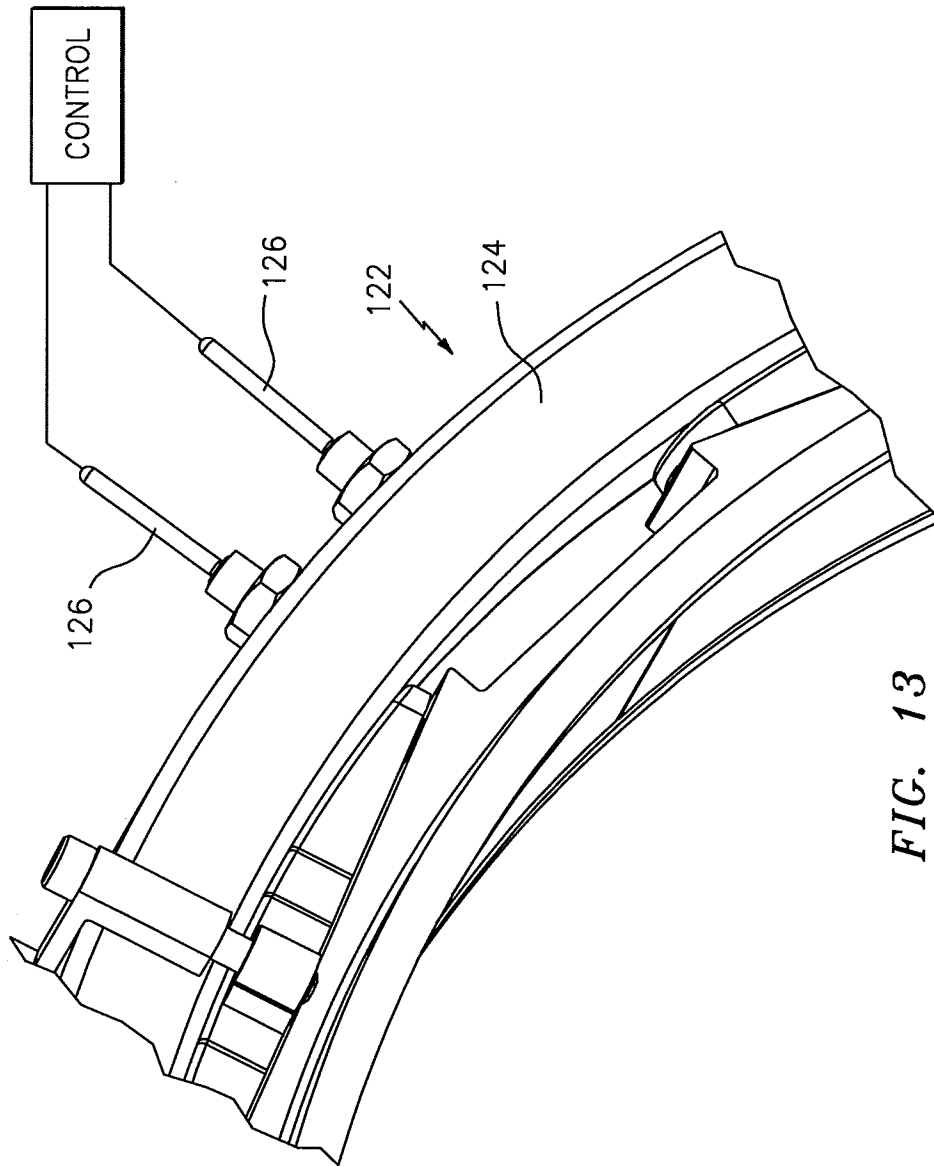

FIG. 13

A. CLASSIFICATION OF SUBJECT MATTER**F01D 11/16(2006.01)i, F01D 11/20(2006.01)i, F02C 7/28(2006.01)i**

According to International Patent Classification (IPC) or to both national classification and IPC

B. FIELDS SEARCHED

Minimum documentation searched (classification system followed by classification symbols)

F01D 11/16; F01D 11/08; F01D 11/20; F01D 11/22; F01D 5/20; F02C 7/28

Documentation searched other than minimum documentation to the extent that such documents are included in the fields searched

Korean utility models and applications for utility models

Japanese utility models and applications for utility models

Electronic data base consulted during the international search (name of data base and, where practicable, search terms used)

eKOMPASS(KIPO internal) & Keywords:turbine engine, blade tip clearance, control, actuate, link, and case

C. DOCUMENTS CONSIDERED TO BE RELEVANT

Category*	Citation of document, with indication, where appropriate, of the relevant passages	Relevant to claim No.
Y	US 5,096,375 A (CLOKALLO, JOHN J.) 17 March 1992 See abstract; column 1, lines 42-44, column 5, line 8 - column 7, line 18; and figures 5-8,12,13.	1-6,15-20
A		7-14
Y	US 5,018,942 A (CLOKALLO et al.) 28 May 1991 See abstract; column 5, line 16 - column 6, line 11; and figures 5-8.	1-6,15-20
A	US 5,056,988 A (CORSMEIER et al.) 15 October 1991 See abstract; column 5, line 60 - column 6, line 17; and figures 5-10.	1-20
A	US 2012-0063884 A1 (KLINGELS, HERMANN) 15 March 2012 See abstract; paragraphs [0068],[0069]; and figures 2-12.	1-20
A	US 5,545,007 A (MARTIN, ANTHONY N.) 13 August 1996 See abstract; column 3, line 48 - column 4, line 30; and figures 1,2.	1-20

 Further documents are listed in the continuation of Box C. See patent family annex.

* Special categories of cited documents:

"A" document defining the general state of the art which is not considered to be of particular relevance

"E" earlier application or patent but published on or after the international filing date

"L" document which may throw doubts on priority claim(s) or which is cited to establish the publication date of another citation or other special reason (as specified)

"O" document referring to an oral disclosure, use, exhibition or other means

"P" document published prior to the international filing date but later than the priority date claimed

"T" later document published after the international filing date or priority date and not in conflict with the application but cited to understand the principle or theory underlying the invention

"X" document of particular relevance; the claimed invention cannot be considered novel or cannot be considered to involve an inventive step when the document is taken alone

"Y" document of particular relevance; the claimed invention cannot be considered to involve an inventive step when the document is combined with one or more other such documents, such combination being obvious to a person skilled in the art

"&" document member of the same patent family

Date of the actual completion of the international search

14 August 2014 (14.08.2014)

Date of mailing of the international search report

14 August 2014 (14.08.2014)

Name and mailing address of the ISA/KR

International Application Division
Korean Intellectual Property Office
189 Cheongsu-ro, Seo-gu, Daejeon Metropolitan City, 302-701,
Republic of Korea

Facsimile No. +82-42-472-7140

Authorized officer

HAN, Joong Sub

Telephone No. +82-42-481-5606

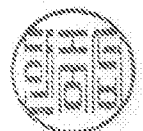

INTERNATIONAL SEARCH REPORT

Information on patent family members

International application No.

PCT/US2014/032199

Patent document cited in search report	Publication date	Patent family member(s)	Publication date
US 5096375 A	17/03/1992	CA 2021104 A1	09/03/1991
		DE 4028329 A1	21/03/1991
		FR 2651832 A1	15/03/1991
		GB 2235731 A	13/03/1991
		GB 9019573 D0	24/10/1990
		IT 1246440 B	18/11/1994
		IT 9021365 A1	09/03/1991
		IT 9021365 D0	03/09/1990
		JP 03-141803 A	17/06/1991
US 5018942 A	28/05/1991	CA 2021085 A1	09/03/1991
		DE 4028330 A1	21/03/1991
		FR 2651830 A1	15/03/1991
		GB 2235732 A	13/03/1991
		GB 9019575 D0	24/10/1990
		IT 1243005 B	23/05/1994
		IT 9021362 A1	09/03/1991
		IT 9021362 D0	03/09/1990
		JP 03-141802 A	17/06/1991
US 5056988 A	15/10/1991	CA 2034405 A1	13/08/1991
		DE 4031477 A1	14/08/1991
		FR 2658242 A1	16/08/1991
		GB 2240818 A	14/08/1991
		GB 9022100 D0	21/11/1990
		IT 1243833 B	28/06/1994
		IT 9021736 A1	13/08/1991
		IT 9021736 D0	12/10/1990
		JP 03-242402 A	29/10/1991
US 2012-0063884 A1	15/03/2012	DE 102009023061 A1	02/12/2010
		EP 2435665 A2	04/04/2012
		EP 2435665 B1	13/02/2013
		US 8678742 B2	25/03/2014
		WO 2010-136018 A2	02/12/2010
		WO 2010-136018 A3	24/02/2011
US 5545007 A	13/08/1996	WO 96-17156 A1	06/06/1996