

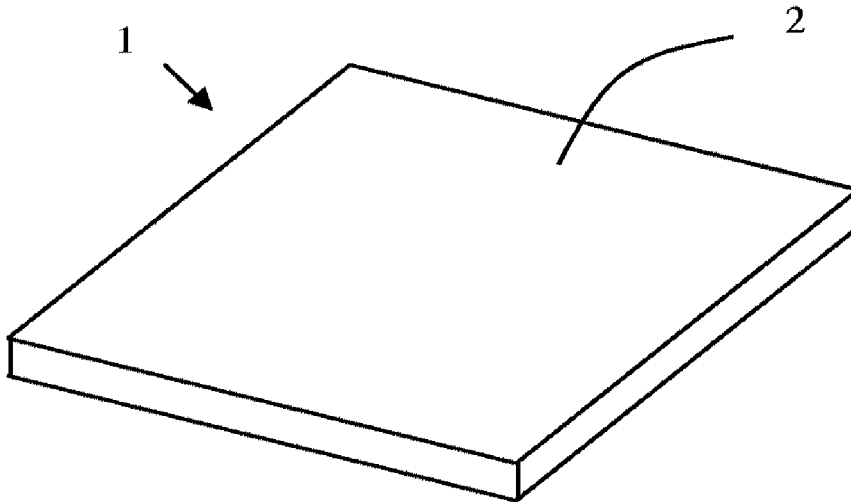

(86) **Date de dépôt PCT/PCT Filing Date:** 2016/09/09
(87) **Date publication PCT/PCT Publication Date:** 2017/03/16
(45) **Date de délivrance/Issue Date:** 2023/12/19
(85) **Entrée phase nationale/National Entry:** 2018/03/09
(86) **N° demande PCT/PCT Application No.:** EP 2016/071378
(87) **N° publication PCT/PCT Publication No.:** 2017/042372
(30) **Priorité/Priority:** 2015/09/11 (EP15020158.0)

(51) **Cl.Int./Int.Cl. E04B 9/00** (2006.01),
E04B 9/04 (2006.01)
(72) **Inventeur/Inventor:**
MOSIADZ, MACIEJ GRZEGORZ, PL
(73) **Propriétaire/Owner:**
ROCKWOOL A/S, DK
(74) **Agent:** MBM INTELLECTUAL PROPERTY AGENCY

(54) **Titre : PANNEAU ACOUSTIQUE**
(54) **Title: ACOUSTIC PANEL**



(57) **Abrégé/Abstract:**

Acoustic panels, grids for acoustic panels, suspended ceiling systems and a method for producing an acoustic panel, especially a man-made vitreous fibre (MMVF) panel, having a first major face and an opposite second major face, with the first major face comprising a facing with a surface coating. To provide high light reflection the coating comprises microspheres.

(12) INTERNATIONAL APPLICATION PUBLISHED UNDER THE PATENT COOPERATION TREATY (PCT)

(19) World Intellectual Property
Organization
International Bureau(10) International Publication Number
WO 2017/042372 A1(43) International Publication Date
16 March 2017 (16.03.2017)

- (51) **International Patent Classification:**
E04B 9/00 (2006.01) *E04B 9/04* (2006.01)
- (21) **International Application Number:**
PCT/EP2016/071378
- (22) **International Filing Date:**
9 September 2016 (09.09.2016)
- (25) **Filing Language:** English
- (26) **Publication Language:** English
- (30) **Priority Data:**
15020158.0 11 September 2015 (11.09.2015) EP
- (71) **Applicant:** ROCKWOOL INTERNATIONAL A/S
[DK/DK]; 584 Hovedgaden, DK-2640 Hedehusene (DK).
- (72) **Inventor:** MOSIADZ, Maciej Grzegorz; Krokusowa 12,
65-012 Zielona Gora (PL).
- (74) **Agent:** SAMUELS, Lucy Alice; The Broadgate Tower, 20
Primrose Street, London Greater London EC2A 2ES (GB).
- (81) **Designated States** (*unless otherwise indicated, for every
kind of national protection available*): AE, AG, AL, AM,

AO, AT, AU, AZ, BA, BB, BG, BH, BN, BR, BW, BY,
BZ, CA, CH, CL, CN, CO, CR, CU, CZ, DE, DK, DM,
DO, DZ, EC, EE, EG, ES, FI, GB, GD, GE, GH, GM, GT,
HN, HR, HU, ID, IL, IN, IR, IS, JP, KE, KG, KN, KP, KR,
KW, KZ, LA, LC, LK, LR, LS, LU, LY, MA, MD, ME,
MG, MK, MN, MW, MX, MY, MZ, NA, NG, NI, NO, NZ,
OM, PA, PE, PG, PH, PL, PT, QA, RO, RS, RU, RW, SA,
SC, SD, SE, SG, SK, SL, SM, ST, SV, SY, TH, TJ, TM,
TN, TR, TT, TZ, UA, UG, US, UZ, VC, VN, ZA, ZM,
ZW.

- (84) **Designated States** (*unless otherwise indicated, for every
kind of regional protection available*): ARIPO (BW, GH,
GM, KE, LR, LS, MW, MZ, NA, RW, SD, SL, ST, SZ,
TZ, UG, ZM, ZW), Eurasian (AM, AZ, BY, KG, KZ, RU,
TJ, TM), European (AL, AT, BE, BG, CH, CY, CZ, DE,
DK, EE, ES, FI, FR, GB, GR, HR, HU, IE, IS, IT, LT, LU,
LV, MC, MK, MT, NL, NO, PL, PT, RO, RS, SE, SI, SK,
SM, TR), OAPI (BF, BJ, CF, CG, CI, CM, GA, GN, GQ,
GW, KM, ML, MR, NE, SN, TD, TG).

Published:

— with international search report (Art. 21(3))

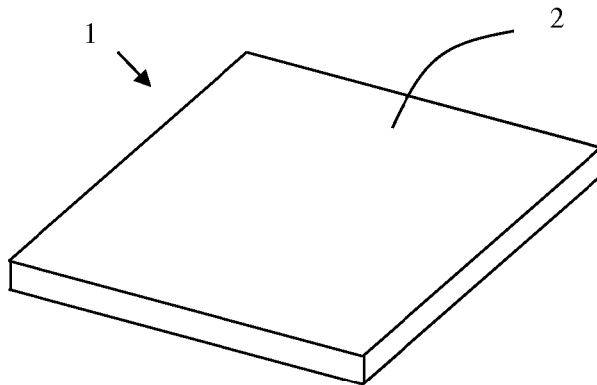
(54) **Title:** ACOUSTIC PANEL

(57) **Abstract:** Acoustic panels, grids for acoustic panels, suspended ceiling systems and a method for producing an acoustic panel, especially a man-made vitreous fibre (MMVF) panel, having a first major face and an opposite second major face, with the first major face comprising a facing with a surface coating. To provide high light reflection the coating comprises microspheres.

Fig. 1

Acoustic panel

The invention relates to acoustic panels, grids for acoustic panels, suspended ceiling systems and a method for producing an acoustic panel, especially a
5 man-made vitreous fibre (MMVF) panel, having a first major face and an opposite second major face, with the first major face comprising a facing with a surface coating.

Acoustic correction is an important part of creating good indoor environments,
10 and this is of increasing concern, e.g. in open plan offices, schools and hospitals. Noise is a disturbing factor, which may have a negative influence on health and productivity. Acoustic panels can be used to achieve high level of acoustical comfort.

15 However in some cases acoustic panels are left out of consideration because the present panels have a surface, which is less than optimum in terms of light reflection.

US2007/0277948 A1 discloses an acoustical tile that includes a core and a
20 surface treatment.

US3908059 discloses a ceiling tile that has a decorative face produced by applying a binder and a vast plurality of minute expandable plastic particles to patterned areas of the tile face and then applying heat to expand the particles
25 and/or dry the binder.

According to a first aspect of the present invention it is an object to provide an acoustic panel with a high light reflection and still having acoustic performance.

30 This object is achieved by the surface coating comprising microspheres.

The microspheres may be made of silica, ceramics or glass. Choice of material for the microspheres may be influenced by cost, demand for strength or processing equipment.

- 5 The diameter of the microspheres may be chosen to fit the purpose, depending on the demands on e.g. acoustics, ease of cleaning, cost, whiteness, processing equipment etc. As an example the average diameter may be in the interval 10-200 μm , for example 10-120 μm , such as 15-70 μm . Generally a lower average diameter may give a more smooth texture, whereas a higher average diameter may reduce gloss. Microspheres with a relatively high average diameter may be more fragile and put constraints on the process equipment.

15 The microspheres provide high light reflection. The effect is comparable with a "bath foam effect"; although the bubbles are colourless, the surface curvature assures a white appearance. In some embodiments the effect may be further enhanced by adding pigment to the microspheres. Alternatively or supplementary the microspheres may have a surface coating or surface treatment.

20 A further advantage is that the microspheres hide the structure of the surface. Often front facings are directional in that e.g. fibres of the facing are predominantly directed in one direction, and this can often be seen in prior art panels. This means that the installer installing the panels must be careful to align all panels making up e.g. a suspended ceiling in the same direction. This is time consuming, and hence adds to the cost of the final ceiling. If adjacent panels are not aligned to have the same direction, it may have a negative effect on the aesthetics of the room.

30 Furthermore the microspheres are found to make the surface coating of the surface more robust, thereby making the surface coating more easy to clean.

According to an embodiment, the facing is a non-woven or a felt having an air permeability of 400-900 $\text{l/m}^2/\text{s}$. Air permeability in this range is found to provide a

good compromise between a closed surface with optimum visual quality in terms of smoothness, light reflection etc and an open surface to provide acoustic performance, in particular sound absorption. The facing may be based on glass fibres, which have a favourable reaction to fire, whereas in other cases the
5 facing may be based on for example plastic fibres to provide a softer facing, or a combination of plastic fibres and glass fibres. The facing may include a pigment or dye to provide the colour wanted, e.g. to provide a white facing with an L-value of at least 95.

10 An aspect of the invention relates to a suspended ceiling grid comprising a surface coating on surfaces visible in the installed state of the suspended ceiling. The surface coating comprises microspheres, which have the effect that the light reflection of the grid surfaces is comparable with the light reflection of the panels. Further it is found that the microspheres make the coated surface
15 more robust and thus easier to clean.

A further aspect of the invention relates to a suspended ceiling system comprising an acoustic panel as defined above and a grid as outlined above.

20 Another aspect of the invention relates to a method for producing an acoustic panel comprising the steps of providing an acoustic panel, especially a MMVF panel, attaching a front facing to a first major face of the panel, applying a surface coating on the front facing, the surface coating comprises microspheres, and that prior to applying the surface coating, the surface coating is conditioned
25 to have a viscosity of 20-40s DIN CUP4.

This specific viscosity range is found to provide a suitable compromise of ease of application of the surface coating, good coverage of the surface, while providing a coating, which will not be too detrimental on the acoustic properties
30 of the panels, especially with regard to sound absorption. In some cases a more narrow range of 28-38s DIN CUP4 may be appropriate.

The microspheres are typically balls of ceramics, glass or silica with vacuum or air filled, and hence the microspheres are relatively light (generally e.g. 0.2 kg/dm³). Due to the light weight of such microspheres, there is a tendency that the microspheres will migrate to the top of a tank containing the coating. Hence
5 the surface coating is conditioned e.g. by mixing or stirring to have a homogeneous viscosity in tank, e.g. with a maximum variation in viscosity of 10% in the coating.

According to an embodiment the surface coating is applied using a low viscosity
10 coating technique, such as using rollers, brushes, spray nozzles or curtain coating.

The invention will be described in the following by way of example with reference to the drawings in which:

15

Figure 1 is a sketch of a panel,

Figure 2 is a close-up photo of a coated surface,

20

Figure 3 is a photo of a coated surface,

Figure 4 is a sketch showing the principles in room acoustics, and

25

Figure 5 is a sketch showing the principles in sound absorption of acoustic panels.

In the sketch of figure 1 is seen a panel (1) having a first major face (2) and an opposite second major face. The first major face (2) is provided with a facing, such as a non-woven or felt.

30

Microspheres (3) of the coating can be seen in the close-up photo of figure 2. As can be seen a number of the microspheres are situated in the surface providing

the optical effect and giving a high light reflection and robustness of the surface coating.

5 Figure 3 is a photo of the surface of the panel, and it can be seen that the coating covers the surface in a way to conceal any directional nature of the facing or subsurface. Further it can be seen that the surface is highly irregular and matt. Irregularity of the surface and the existence of small pinholes in the surface coating safeguards the acoustic performance of the panel.

10 In the sketch of figure 4 is illustrated how the acoustic performance of a room is influenced by external sound sources, and further by sound in the room reflected by the floor, walls and ceiling.

15 Figure 5 shows how incident sound may be absorbed in an acoustic panel if the incident sound is allowed to penetrate into the panel through the first major face (2), whereas some of the sound may be reflected back into the room.

Scrub testing

20 A test to determine wet-scrub resistance of coated ceiling panels was carried out. Test samples were 430 x 110 x 6 mm panels of MMVF with a facing and coating including microspheres. The test was performed on an Erichsen scrub resistance tester in compliance with PN-EN ISO 11998:2007 requirements, however a soft PU sponge and not a brush, was used as a scrub body. The appearance of the coatings was assessed after 100, 200 and 500 cycles. Rating
25 scale 1-5 was used to describe test results (1 = Best, 5 = Worst):

- Class 1 – minute changes visible,
- Class 2 – small thickness loss overall entire surface, no clearances to the surface, visible gloss loss, minute runs,
- Class 3 – visible thickness loss and clearances to the surface, significant
30 gloss changes and runs,
- Class 4 – significant loss of a coating thickness and in some areas a panel surface becomes visible,
- Class 5 – the panel surface damages (up to 100%).

As can be seen in the table below the sample showed excellent scrub resistance.

Sample	Results after 100 scrub cycles		Results after 200 scrub cycles		Results after 500 scrub cycles	
	Appearance	Quality class	Appearance	Quality class	Appearance	Quality Class
Acoustic panel	No changes	1	Shine, minute thickness loss	2	Shine, minute thickness loss	2

5 Table 4

Sound absorption test

A sample measuring 1200x600x20 mm was tested for sound absorption according to BS EN ISO 354:2003 with very favourable results. Sound absorption coefficient of $\alpha_w=1.00$ was reached (Class A), calculated to EN ISO 11654:1997 and NRC 0.95 calculated to ASTM C 423-01.

10

Light reflection testing

Measurement of light reflection of a sample of a panel provided with a coating with microspheres was performed. Spectral reflection was measured using a Perkin-Elmer Lambda 900 spectrophotometer equipped with an integrating sphere, geometry 8°/d. Reflection values, including and excluding specular components, was measured in steps of 5 nm from 380 up to and including 780 nm. From the results the X, Y, Z, x, y and L*, a* and b* coordinates were derived for a light source D65 and an observer of 10° (ISO 7724).

15

20

Additionally diffusivity measurements were executed with calibration in “including specular component” modus, while the actual measurement were executed in the “excluding specular components” modus. By doing so the amount of diffuse reflected light compared to the total amount of reflected light is measured.

25

Gloss was measured using a BYK-trigloss multiangle gloss measuring device. This device projects a light beam onto the sample's surface and measures the intensity of the specular reflected light. The angle can be chosen 20°, 60° or 85°. The intensity of the reflected light beam is expressed in gloss units.

5

Sample, acoustic panel	L*
Reflection, including specular gloss, average	94.91
Reflection, excluding specular gloss, average	94.57

Table 1

Sample, acoustic panel	L*/L* incl gloss (%)
Diffuse reflection, average	99.78

Table 2

Sample, acoustic panel	Gloss (gloss units)
Measuring angle	Average
20°	1.2
60°	1.7
85°	0.2

10 Table 3

Diffusivity is very high, and the very high diffusivity is confirmed by the results of the gloss measurements, which show extremely low values.

15 With the high light reflection and low gloss the panels provide more light in a room equipped with the panels, and thereby the cost of lighting may be reduced, and further the living conditions are improved with a positive influence on the mood and productivity of people in the room.

THE EMBODIMENTS OF THE INVENTION FOR WHICH AN EXCLUSIVE PROPERTY OR PRIVILEGE IS CLAIMED ARE DEFINED AS FOLLOWS:

- 5 1. A man-made vitreous fibre (MMVF) acoustic panel, having a first major face and an opposite second major face, with the first major face comprising a facing with a surface coating, characterized in that the surface coating comprises microspheres, wherein the average diameter of the microspheres is in the interval of 10-200 μm , wherein the facing is a non-woven or a felt having an air permeability of 400-900 $\text{l/m}^2/\text{s}$.
- 10 2. Acoustic panel according to claim 1, wherein the microspheres are made of silica, ceramic or glass.
3. Acoustic panel according to claim 1 or 2, wherein the average diameter of the microspheres is in the interval of 10-120 μm .
4. Acoustic panel according to claim 3, wherein the average diameter of the
15 microspheres is in the interval of 15-70 μm .
5. Acoustic panel according to any one of claims 1 to 4, wherein the panel is a MMVF panel having a density in the range of 40-150 kg/m^2 .
6. Acoustic panel according to claim 5, wherein the panel is a MMVF panel having a density in the range of 60-130 kg/m^2 .
- 20 7. Acoustic panel according to any one of claims 1 to 6, wherein the facing is based on glass fibres.
8. Suspended ceiling system comprising
 - a. a plurality of MMVF acoustic panels as defined in claim 1, each having a first major face and an opposite second major face, with the first major
25 face comprising a facing; and
 - b. a grid;wherein the suspended ceiling comprises a surface coating on surfaces visible in the installed state of the suspended ceiling, characterized in that the surface coating comprises microspheres, wherein the average diameter
30 of the microspheres is in the interval of 10-200 μm , and in that the facing is a non-woven or a felt having an air permeability of 400-900 $\text{l/m}^2/\text{s}$.
9. Suspended ceiling system according to claim 8, wherein the average diameter of the microspheres is in the interval of 10-120 μm .

10. Suspended ceiling system according to claim 8, wherein the average diameter of the microspheres is in the interval of 15-70 μm .
11. Method for producing a man-made vitreous fibre (MMVF) acoustic panel comprising the steps of:
 - 5 providing a MMVF panel,
attaching a front facing to a first major face of the panel, wherein the facing is a non-woven or a felt having an air permeability of 400-900 $\text{l/m}^2/\text{s}$, and
applying a surface coating on the front facing,
characterized in that the surface coating comprises microspheres having an
10 average diameter in the interval of 10-200 μm , and that prior to applying the surface coating, the surface coating is conditioned to have a viscosity of 20-40s DIN CUP4.
 12. Method according to claim 11, wherein the surface coating is applied using a low viscosity coating technique.
 - 15 13. Method according to claim 12, wherein the low viscosity coating technique comprises using rollers, brushes, spray nozzles or curtain coating.

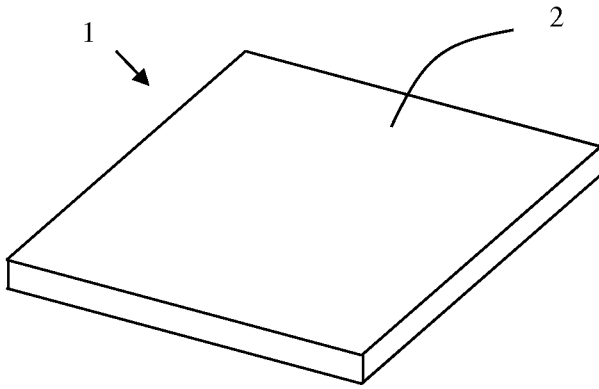

Fig. 1

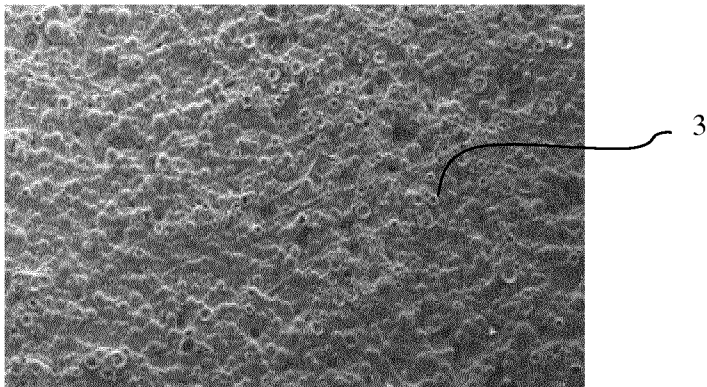

Fig. 2



Fig. 3

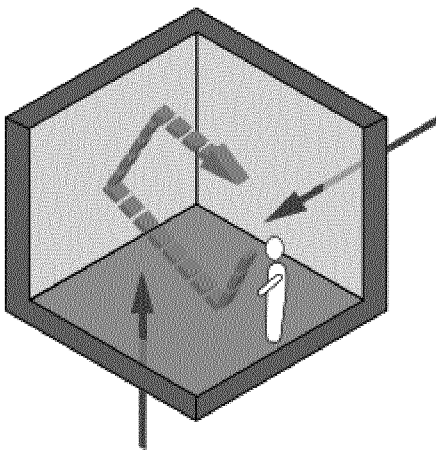

Fig. 4

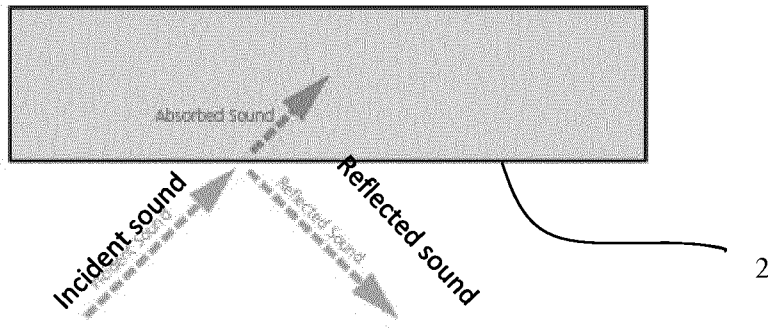

Fig. 5

