

May 31, 1938.

F. MEYER

2,119,284

SHAVING MECHANISM

Filed March 29, 1938

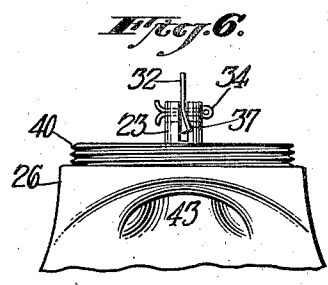
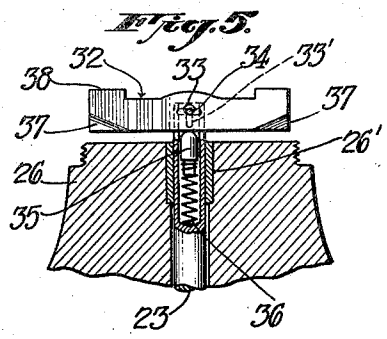
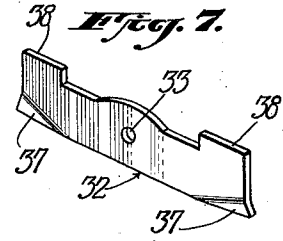
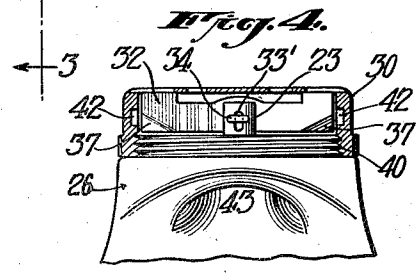
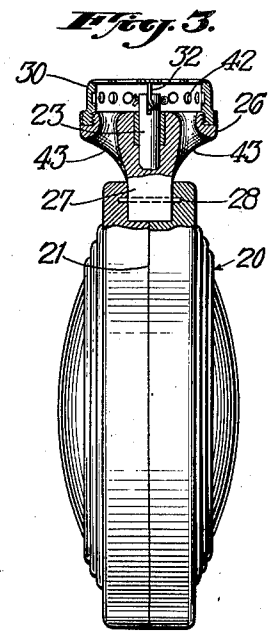
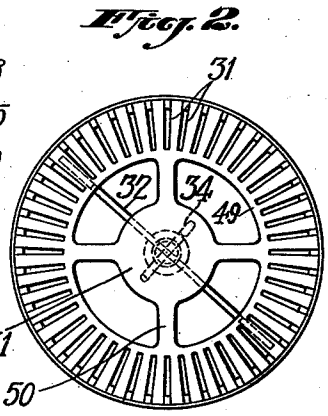
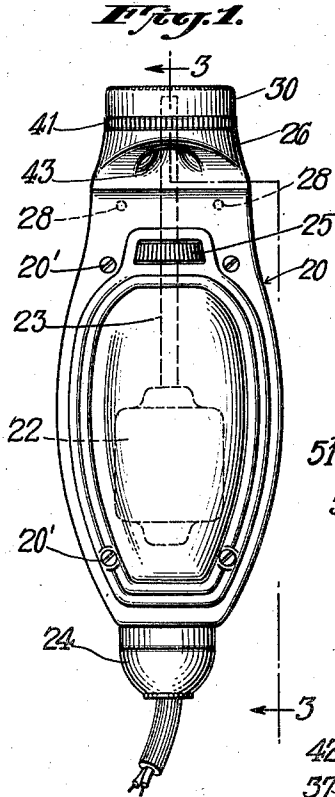

INVENTOR  
**FREDERICK MEYER.**  
BY  
*Ward, Crosby & Neal*  
ATTORNEYS

# UNITED STATES PATENT OFFICE

2,119,284

## SHAVING MECHANISM

Frederick Meyer, Union, N. J., assignor to Art Metal Works, Inc., Newark, N. J., a corporation of New Jersey

Application March 29, 1938, Serial No. 198,734

5 Claims. (Cl. 30-43)

This invention relates to shaving mechanisms, more particularly of a type wherein an apertured guard member is pressed against and moved over the surface to be shaved, with a power-driven cutting element operating within or beneath such guard to shave off the stubble as it protrudes through the apertures.

While a shaving mechanism was proposed many years ago of a type having a circular apertured guard to be pressed into contact with the face, and having a rotary cutting element bearing against the interior surface of such guard, such devices have not enjoyed any substantial practical use. The present invention in its preferred form, while relating more particularly to mechanisms of this general character, has for its objects the elimination of certain difficulties heretofore encountered with this type of device, and the provision of a simple, durable shaving mechanism with which one may very quickly obtain an unusually smooth shave without danger of abrasion or injury to the skin.

Various further and more specific objects, features and advantages will clearly appear from the detailed description given below, taken in connection with the accompanying drawing which forms a part of this specification and illustrates merely by way of example, certain preferred forms of the invention. The invention consists in such novel features, arrangements and combinations of parts as may be shown and described in connection with the devices herein disclosed.

In the drawing, Fig. 1 is a side elevational view of one form of shaving device embodying the invention;

Fig. 2 is an end view showing the form of the guard and its relationship to the cutter in the device;

Fig. 3 is a view taken substantially along the line 3-3 of Fig. 1;

Fig. 4 is an enlarged sectional view of the head portion of the device;

Fig. 5 is an enlarged sectional view showing further details within the head portion of the device and with the guard removed;

Fig. 6 is another enlarged view of the head portion of the device with the guard removed; and

Fig. 7 is a perspective view showing the cutter member of the device.

Referring now to the drawing in further detail, the device may comprise a handle and casing portion 20 preferably formed of suitable rigid insulation material such as a phenol-formaldehyde condensation product. This handle may be

split along a longitudinally extending plane as at 21 (Fig. 3) and may be made hollow for receiving a suitable electrical motor as indicated at 22, having a shaft 23 extending axially of the handle and upwardly into the head portion of the device. Suitable plug and socket electrical power connecting means as at 24 for the motor, may be provided at the lower end of the handle.

The shaft 23 may be provided with a knurled wheel as at 25 protruding through an aperture formed in one of the halves of the casing portion near the head of the device, whereby in case the motor is not self-starting, it may be readily started by moving one's finger over such knurled wheel.

The head portion of the device may comprise a rigid casting 26 serving as an enclosure for the upper end of the shaft 23, and support for the guard, as hereinafter described. This casting may have a lower portion of generally rectangular shape as 27 terminating in a tongue portion adapted to be received within a corresponding groove formed in the upper ends of the adjoining complementary halves of the handle. Two or more small pins as at 28 may extend through the portion 27 and for a short distance into the adjacent portions of the handles for securing the casting 26 against removal, except when the halves of the handle are separated. The handle portions may be removably secured together with the motor and shaft therein as by the use of suitable screws as at 29.

A circular guard member 30 may be secured to the upper end of the support 26. The outer surface of the guard member 30 for contacting with the skin to be shaved may be substantially flat and of extremely thin relatively rigid sheet-like material formed with numerous apertures such as radially extending slots 31 at its peripheral areas, these slots being of sufficient width to properly admit the stubble, but just insufficient to permit the skin to enter and be injured by the cutter. As shown, the slots may extend to the very periphery of the guard member 30, thus providing open-ended slots (see Fig. 1) permitting free entrance of the stubble when the guard is moved over the skin to be shaved. In order to strengthen the guard at the inner ends of the radially extending slots, such inner ends may be closed by a continuous narrow annular area as at 49. The central area of the guard may be left largely open or if desired, as shown, four or more radially extending arms or braces as at 50 may extend from the annular area 49 to a central rigid area 51. The area 51 will serve

to cover the central area of the cutter member to prevent the skin from contacting therewith.

A rotatable cutting member 32 may be mounted within said guard member so as to be concealed, covered and protected thereby. The cutter member may be apertured as at 33 at its mid-portion so as to be pivotally mounted on a cutter pin or the like 34, extending transversely through a slot 33' in the upper end of the shaft 23 (Figs. 4 to 6). The upper end of the shaft 23 may be split as shown to receive the cutter member 32, and also provided with a small longitudinally extending cylindrical aperture for slidably receiving a small pin 35 having a rounded upper end bearing against the cutter member and having its lower end yieldably supported as by a spiral spring 36. This arrangement is such that the cutter member is yieldably pressed against the inside surface of the guard with a substantially uniform pressure throughout the length of its cutting edges 38. The spring 36 is preferably received within the end of the shaft 23 (Fig. 5) so that the spring which may preferably be quite delicate and highly yieldable, is housed and protected by the walls of the shaft against being interfered with by the cutting. Also the spring in this position permits of a compact arrangement of a longer spring than would be possible if the spring were outside the shaft where it would interfere with the shaft bearings unless the device were unduly elongated. As shown, the upper end of the shaft 23 may be mounted within a small cylindrical brass or bronze bearing piece as at 26', fixed within the casting 26.

The cutting element 32 may be suitably shaped to provide a fan action for purposes hereinafter more fully explained, as well as to strengthen the construction. For example, the lower outer corners 37 of the cutting element may be bent in opposite directions respectively from the plane of the remainder of the cutting element, i. e., in a direction so as to produce a downward draft of air.

The guard member may be detachably secured to the casting 26 with a threaded engagement as indicated at 40. The outer lower edge of the guard member may be knurled as at 41 to facilitate screwing the guard member into place or removal thereof.

While the active portion of the guard member is preferably made as thin as possible of sheet-like material comprising, for example, hard tool steel of preferably uniform thickness, the outer supporting ring for the guard member is preferably made considerably thicker so as to form a rigid support strengthening the guard against flexure or breakage. The inner surface of the cylindrical portion of the guard member may be partially cut away as by the use of perforations as at 42, enabling the cuttings to more freely pass from the upper edge of the cutter downwardly and out through apertures as at 43 formed at the base of the cylindrical portion of the head of the device and adjacent the sides of the rectangular portion 27.

The rotary form of cutter in the preferred form of this invention eliminates the necessity for any reciprocating, vibratory or oscillating parts, as well as avoiding cam mechanisms and the like. Hence unpleasant chattering or vibration of the device against the hand and face of the user are avoided, as are also troubles due to friction, heating and wearing of cam surfaces and the like. In short, the construction pro-

vides a compact smoothly rotating shaft and cutter structure of exceptional simplicity and durability.

While the revolving cutting element as shown may comprise a rigid element of hardened steel insuring long wear with efficient cutting, the pivotal and yieldable support by which it is affixed to the shaft, insures that both arms of the cutter will uniformly bear against the inside guard surface even though the cutter edges and guard may not be perfectly machined or in exact axial alignment as assembled. At the same time, if one of the arms of the cutter should encounter an unusual obstruction projecting through an aperture, such arm will be free to yield somewhat due to the spring support of the cutter without jamming or unduly slowing the motor.

The formation of the cutter arms with angular or bent lower corner portions, gives to the cutter a fan action for expelling the cuttings through apertures 43, thus preventing the cuttings from passing back through the apertures and smearing over the skin. This is particularly advantageous in case the skin is covered with perspiration, which would otherwise cause the cut hair to adhere to a troublesome degree. The fan action also provides a draft of cooling air through the head of the mechanism at such times as the guard apertures or portions thereof are uncovered. When substantially all of the guard apertures are covered by the skin, the fan action tends to provide a suction effect promoting the entrance of the stubble areas into the slots.

This application is a continuation in part of applicant's copending application Ser. No. 189,554, filed February 9, 1938.

While the invention has been described in detail with respect to particular preferred examples, it will be understood by those skilled in the art after understanding the invention, that various changes and further modifications may be made without departing from the spirit and scope of the invention, and it is intended therefore in the appended claims to cover all such changes and modifications.

What is claimed as new and desired to be secured by Letters Patent is:

1. Shaving mechanism including a power-driven rotatable shaft, a cutter member having a cutting edge extending generally radially from an end of said shaft, said member being fixed to rotate with said shaft by a pivot member, the axis of said pivot member also extending radially of the shaft but transversely of said edge, and an apertured guard member having an interior surface extending transversely with respect to said end of said shaft and comprising a surface of revolution against which said edge bears.

2. Shaving mechanism including a power-driven rotatable shaft, a cutter member having cutting edges extending generally radially to each side of an end of said shaft, said member being fixed to rotate with said shaft by a pivot member permitting pivotal movement of said cutter member about axes transverse to said shaft, and an apertured guard member extending generally at right angles to said shaft having an interior surface comprising a surface of revolution against which said edges bear.

3. Shaving mechanism including a power-driven rotatable shaft, a cutter member having cutting edges extending generally radially to each side of an end of said shaft, said member being fixed to rotate with said shaft by a pivot member

5 permitting pivotal movement of said cutter member about axes transverse to said shaft, an apertured guard member having an interior surface extending transversely with respect to said end of said shaft and comprising a surface of revolution, and spring means causing said cutting edges to bear against said surface.

10 4. Shaving mechanism including a power-driven rotatable shaft, a cutter member having a cutting edge extending generally radially from an end of said shaft, said member being fixed to rotate with said shaft by pivotal means, the axis of said pivotal means also extending radially of the shaft but transversely of said edge, an apertured guard member having an interior surface comprising a surface of revolution against which  
15 said edge bears, and spring means within the end

of said shaft causing said edge to bear against said surface.

5 5. Shaving mechanism including a power-driven rotatable shaft, supporting means surrounding said shaft, a circular guard member fixed to said means and adapted to be pressed against the skin to be shaved and with the shaft directed endwise toward the skin, and cutter means within said guard, said supporting means including a portion of a generally rectangular cross section merging into a generally cylindrical portion extending longitudinally of said shaft for receiving said circular guard, an outlet opening for the escape of cuttings from within the guard, being formed at the base of said cylindrical portion and adjacent a side of the rectangular portion.  
10  
15

FREDERICK MEYER.