



(51) International Patent Classification:

E21B 17/01 (2006.01) *E21B 23/08* (2006.01)
E21B 4/06 (2006.01)

(21) International Application Number:

PCT/US20 13/040076

(22) International Filing Date:

8 May 2013 (08.05.2013)

(25) Filing Language:

English

(26) Publication Language:

English

(71) Applicant: **HALLIBURTON ENERGY SERVICES, INC.** [US/US]; 10200 Bellaire Blvd., Houston, Texas 77072 (US).

(72) Inventors: **GAWSKI, Victor**; Moss Side Farm, Whitecaims, Aberdeenshire United Kingdom AB23 8XA (GB). **SNYDER, John Kenneth**; 18603 Duke Lake Drive, Spring, Texas 77388 (US).

(74) Agent: **RIPPAMONTI, Russell N.**; Fish & Richardson P.C., P. O. Box 1022, Minneapolis, Minnesota 55440-1022 (US).

(81) Designated States (*unless otherwise indicated, for every kind of national protection available*): AE, AG, AL, AM, AO, AT, AU, AZ, BA, BB, BG, BH, BN, BR, BW, BY, BZ, CA, CH, CL, CN, CO, CR, CU, CZ, DE, DK, DM, DO, DZ, EC, EE, EG, ES, FI, GB, GD, GE, GH, GM, GT, HN, HR, HU, ID, IL, IN, IS, JP, KE, KG, KM, KN, KP, KR, KZ, LA, LC, LK, LR, LS, LT, LU, LY, MA, MD, ME, MG, MK, MN, MW, MX, MY, MZ, NA, NG, NI, NO, NZ, OM, PA, PE, PG, PH, PL, PT, QA, RO, RS, RU, RW, SC, SD, SE, SG, SK, SL, SM, ST, SV, SY, TH, TJ, TM, TN, TR, TT, TZ, UA, UG, US, UZ, VC, VN, ZA, ZM, ZW.

(84) Designated States (*unless otherwise indicated, for every kind of regional protection available*): ARIPO (BW, GH, GM, KE, LR, LS, MW, MZ, NA, RW, SD, SL, SZ, TZ, UG, ZM, ZW), Eurasian (AM, AZ, BY, KG, KZ, RU, TJ, TM), European (AL, AT, BE, BG, CH, CY, CZ, DE, DK, EE, ES, FI, FR, GB, GR, HR, HU, IE, IS, IT, LT, LU, LV,

[Continued on nextpage]

(54) Title: INSULATED CONDUCTOR FOR DOWNHOLE DRILLING

(57) Abstract: A downhole drilling tool includes a tubular housing having a first longitudinal end and a second longitudinal end, and a stator disposed in the tubular housing, said stator defining an internal cavity passing there through. The stator includes at least a first protective electrically insulated layer, a second protective electrically insulated layer, and an electrically conductive layer disposed between the first and second protective layers. The electrically conductive layer coupled at a first end to a first electrical device and coupled at a second end to a second electrical device. A rotor is operatively positioned in the internal cavity to cooperate the stator. In some implementations, the stator may provide electrical connectivity through the stator without significantly impacting the physical operational integrity of the drilling tool components.

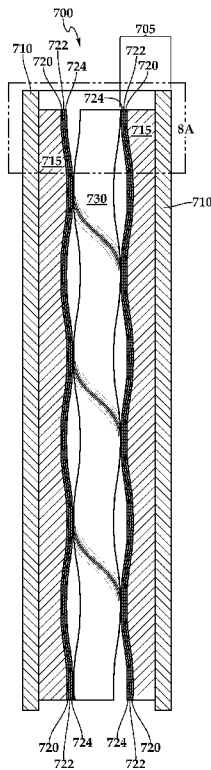

Fig. 8

WO2014/182293 A1

MC, MK, MT, NL, NO, PL, PT, RO, RS, SE, SI, SK, **Published:**
SM, TR), OAPI (BF, BJ, CF, CG, CI, CM, GA, GN, GQ, — *with international search report (Art. 21(3))*
GW, ML, MR, NE, SN, TD, TG).

Insulated Conductor for Downhole Drilling Equipment

TECHNICAL FIELD

[0001] The present disclosure relates to systems, assemblies, and methods for conducting electrical power to and through downhole tools attached to a drill string.

BACKGROUND

[0002] Progressing cavity motors, also known as Moineau-type motors having a rotor that rotates within a stator using pressurized drilling fluid, have been used in wellbore drilling applications for many years. Some Moineau-type pumps and motors used in wellbore drilling include stators which have a polymer lining applied to the bore of the housing. Pressurized drilling fluid (e.g., drilling mud) is typically driven into the motor and into a cavity between the rotor and the stator lining, which generates rotation of the rotor and a resulting torque can be produced. The resulting torque is typically used to drive a working tool, such as a drill bit, to cut material.

DESCRIPTION OF DRAWINGS

[0003] FIG. 1 is a schematic illustration of a drilling rig and downhole equipment disposed in a wellbore.

[0004] FIG 2A illustrates a side view of an example downhole drilling assembly including a downhole drilling tool with portions of a tubular housing cut away for illustrating internal features of the downhole drilling motor.

[0005] FIG. 2B is a cross-sectional view of a stator and rotor of a downhole drilling tool operatively positioned in a cavity defined by a stator disposed in the tubular housing.

[0006] FIGs. 3A-3C are cross-sectional views of an example stator that includes an insulated conductor.

[0007] Figs 3D and 3E are cross sectional views of another implementation of an example stator disposed in a tubular housing.

[0008] FIGs. 4A-4F illustrate example configurations of some implementations of stator and rotor lobes

[0009] FIG. 5 is a cross-sectional view of another example stator that includes a substantially straight insulated conductive strip.

[0010] FIGs. 6A-6B are cross-sectional views of an example stator that includes multiple insulated conductors.

[0011] FIG. 7 illustrates a conceptual example implementation of a stator that includes an insulated conductor.

[0012] FIGs. 8 and 8A are cross-sectional side views of a stator and rotor of a downhole drilling motor.

[0013] FIG. 9A is a cross-sectional view of an example sectional stator of a downhole drilling motor.

[0014] FIG. 9B is an end view of an example stator section.

[001 5] FIG. 10 is an end view of another example stator section.

[001 6] FIG. 11 is a flow diagram of an example process for using a stator that includes an insulated conductor

DETAILED DESCRIPTION

[0017] Referring to FIG. 1, in general, a drilling rig 10 located at or above the surface 12 rotates a drill string 20 disposed in the wellbore below the surface. The drill string typically includes drill pipe 22 and drill collars 24 that are rotated and transfer torque down the borehole to a drill bit 50 or other downhole equipment 40 (referred to generally as the "tool string") attached to a distal end of the drill string. The surface equipment 14 on the drilling rig rotates the drill string 20 and the drill bit 50 as it bores into the Earth's crust 25 to form a wellbore 60.

[001 8] In various implementations, the drill string includes a Moineau motor and the tool string 40 includes equipment that uses electrical power to operate (e.g., motors), equipment that is configured to receive electrical signals (e.g., actuators), and/or equipment that is configured to transmit electrical signals (e.g., sensors) to and/or from electrical equipment 55 located at the surface 12. The electrical equipment 55 is electrically connected to the drill string 20 by at least one electrical conductor 57. Rotation of the drill string 20 and components within the drill string 20, as well as the harsh environment of the wellbore 60, can lead to breakage of conventional electrical conductors. Such breakage results in additional work and expense needed to identify the location of the fault, to retrieve

the corresponding section of the drill string, and to repair the damage, in addition to the costs associated with the resulting downtime

[0019] Progressing cavity motors, such as those used in downhole drilling and pump assemblies, typically include a stator defining cavity and a rotor that is sized and configured to rotate within the cavity when pressurized fluid is applied to the cavity. FIG. 2A illustrates an example drilling assembly 50 disposed in the wellbore 60. In some implementations, the drilling assembly 50 can be the drill string 20. The distal end of the drilling assembly 50 includes the tool string 40 driven by a downhole motor 100 connected to the drill bit 50. The downhole motor 100 generally includes a tubular housing 102, which is typically formed of steel and encloses a power unit 104. The power unit 104 includes a stator 120 and a rotor 122. Referring to FIG. 2B, the stator 120 includes multiple (e.g., five) lobes, the rotor always has one less lobe than the stator 124 defining a cavity 134. The stator 120 can have two or more lobes. See exemplary configurations in FIGs. 4A to 4F.

[0020] The rotor 122 is operatively positioned in the cavity 134 to cooperate with the stator lobes 124. Applying fluid pressure to the cavity 134 typically causes the rotor 122 to rotate within the stator 120 in cooperation with the lobes 124. For example, referring to FIGs. 2A and 2B, pressurized drilling fluid 90 (e.g., drilling mud) can be introduced at an upper end of the power unit 104 and forced down through the cavity 134. As a result of the pressurized drilling fluid 90 flowing through the cavity 134, the rotor 122 rotates which causes the drill bit 136 to rotate and cut

away material from the formation. From the cavity 134, the drilling fluid 90 is expelled at the lower end and then subsequently exhausted from the motor then the drill bit 50.

[0021] During a drilling operation, the drilling fluid 90 is pumped down the interior of the drill string 20 (shown broken away) attached to downhole drilling motor 100. The drilling fluid 90 enters cavity 134 having a pressure that is imposed on the drilling fluid by pumps (e.g., pumps at the surface). The pressurized drilling fluid entering cavity 134, in cooperation with the geometry of the stator 120 and the rotor 122, causes the rotor 122 to turn to allow the drilling fluid 90 to pass through the motor 100. The drilling fluid 90 subsequently exits through ports (e.g., jets) in the drill bit 50 and travels upward through an annulus 130 between the drill string 20 and the wellbore 60 and is received at the surface where it is captured and pumped down the drill string 20 again.

[0022] These downhole drilling motors fall into a general category referred to as Moineau-type motors. Some conventional Moineau-type pumps and motors include stators that have stator contact surface formed of a rubber or polymer material bonded to the steel housing. However, in the dynamic loading conditions typically involved in downhole drilling applications, substantial heat can be generated in the stator and the rotor. Since rubber is generally not a good heat conductor, thermal energy is typically accumulated in the components that are made of rubber (e.g., the stator). This thermal energy accumulation can lead to thermal degradation and,

therefore, can lead to damage of the rubber components and to separation of the rubber components

[0023] Additionally, in some cases, the drilling fluid to be pumped through the motor is a material that includes hydrocarbons. For example, oil-based or diesel-based drilling fluids can be used which are known to typically deteriorate rubber. Such deterioration can be exacerbated by the accumulation of thermal energy. Water and water based fluids can present a problem for rubber components in drilling applications.

[0024] For optimum performance of the drilling motor, there is typically a certain required mating fit (e.g., clearance or interference) between the rubber parts of the stator and the rotor. When the rubber swells, not only the efficiency of the motor is affected but also the rubber is susceptible to damage because of reduced clearance or increased interference between the rotor and the stator.

[0025] Contact between the stator and the rotor during use causes these components to wear (i.e., the rubber portion of the stator or the rotor), which results in the mating fit between the stator and the rotor to change. In some cases, the rotor or the stator can absorb components of the drilling fluid and swell, which can result in the clearance getting smaller, causing portions of the rotor or stator to wear and break off. This is generally known as chunking. In some cases, the chunking of the material can result in significant pressure loss so that the power unit is no longer able to produce suitable power levels to continue the drilling operation. Additionally or alternatively, in some cases, chemical components in the

drilling fluid used can degrade the rotor or the stator and cause the mating fit between them to change. Since the efficient operation of the power unit typically depends on the desired mating fit (e.g., a small amount of clearance or interference), the stator and/or the rotor can be adjusted during equipment maintenance operations at surface to maintain the desired spacing as these components wear during use.

[0026] In some implementations, the tool string 40 includes electrical elements such as motors, actuators and sensors that are in electrical communication with electrical equipment 55 located at the surface 12. The previously discussed downhole conditions can be highly adverse to conventional electrical conductors, such as insulated wires, as such conductors may interfere with the mechanical operation of the drill string 20 or may be susceptible to breakage, erosion, corrosion, or other damage when exposed to the conditions experienced during drilling operations. In order to provide power to such electrical elements, the drill string 20 and/or elements of the tool string 40 include electrically conductive elements that will be discussed in the descriptions of FIGs. 3-1 1.

[0027] FIGs. 3A-3C are cross-sectional views of an example stator 300 of a downhole drilling tool (e.g., a downhole motor 300) that includes an insulated conductive layer 320. In some implementations, the stator 300 can be part of the drill string 20 of FIG. 1 or the stator 120 of FIGs. 2A-2B.

[0028] In some implementations the insulated conductors disclosed herein may be used to pass one or more electrical conductors through housings and around drive shafts of other downhole drilling tools such as RSS

steerable tools, turbines, anti-stall tools and downhole electric power generators. In other implementations, the insulated conductors may be passed through downhole reciprocating tools such as jars and anti-stall tools.

[0029] In general, when used with components such as the bores of downhole motor stator housings, the insulated conductive layer 320 can take the form of a circumferential layer, a semi circumferential layer, a thin straight strip, a spiral strip, or any other appropriate conductive layer which is insulated, geometrically unobtrusive (e.g., thin in wall section, with good adhesion), and does not negatively affect stator elastomer bonding or geometry integrity.

[0030] The stator 300 includes a tubular housing 310 which is typically formed of steel. The insulated conductive layer 320 is included substantially adjacent to an inner surface of the tubular housing 310. The insulated conductive layer 320 may be formed as a circumferential layer, a semi circumferential layer, a thin straight strip, a spiral strip, or any other appropriate conductive layer. In some implementations, the insulated conductive layer 320 may conform to the geometry of the inner surface of the tubular housing 310.

[0031] Referring now to FIG. 3C, a section of the stator 300 is shown in greater detail. The insulated conductive layer 320 includes a conductive sub-layer 322, an insulating sub-layer 324a, and an insulating sub-layer 324b. The conductive sub-layer 322 is formed of an electrically conductive material that is molded, extruded, sprayed, or otherwise formed to

substantially comply with the geometry of the inner surface of the tubular housing 310. The insulating sub-layers 324a, 324b provide electrical insulation between the conductive sub-layer 322 and other adjacent layers (e.g., the tubular housing 310) and/or from other conductive layers as will be discussed in the descriptions of FIGs. 4A-4B and 5. In some implementations, the insulating sub-layers 324a, 324b may be molded, sprayed, or otherwise formed using polymers or non-electrically conductive metallic materials to an electrically insulating sleeve substantially adjacent to the conductive sub-layer 322. In general, the conductive sub-layer 322 is sandwiched between the insulating sub-layer 324a and the insulating sub-layer 324b. The insulating sub-layers 324a, 324b may be applied to the full circular bore or the full outer surface of the tubular housing 310, or may be applied to discrete areas, with the conductive sub-layer 322 placed between the insulated areas. In some embodiments, the conductive sub-layer 322 can be formed or assembled as a series of insulated conductive rings or cylindrical sub-sections along the inner surface of the tubular housing 310.

[0032] In some embodiments, the insulating sub-layer 324b can be a protective layer provided radially between the conductive sub-layer 322 and the bore of the tubular stator 300. The insulating sub-layer 324b can protect the conductive sub-layer 322 from the erosive and abrasive conditions that may be present within the bore, e.g., wear from contact with a rotor or shaft, wear and erosion from mud or other fluid flows, chemical degradation due to substances carried by drilling mud or fluid

flows. In some embodiments, the insulating sub-layer 324b can be molded, sprayed, or otherwise take the form of a protective sleeve. In some embodiments, the insulating sub-layer 324b may implement nanoparticle technology, and/or may be thin, e.g., a fraction of a millimeter, to several millimeters thick. In some embodiments, the insulating sub-layer 324b may provide anti-erosion, anti-abrasion properties, and/or electrical insulating properties.

[0033] In some implementations, the width, thickness, and material used as the conductive sub-layer 322 may be selected based on the amount of data or power that is expected to be transmitted through it. In some implementations, the conductive material, geometry, and/or location of the conductive sub-layer 322 may be selected to allow for the bending, compressing, and/or stretching of the drilling tubulars as is experienced in a downhole drilling environment.

[0034] Figures 3D and 3E illustrate alternative stator geometry for the insulating sub layer 324b.

[0035] FIGs. 4A to 4F illustrate example configurations of additional example embodiments of stator and rotor lobes. FIG. 4A is a cross-sectional end view 1100a of an example stator 1105a that includes an example tubular housing 1110a, an example elastomer layer 1115a, an example conductive sub-layer 1122a, an example insulating layer 1124a, and an example rotor 1130a. FIG. 4B shows a cross-sectional end view 1100b of an example stator 1105b that includes an example tubular housing 1110b, an example elastomer layer 1115b, an example

conductive sub-layer 1122b, an example insulating layer 1124b, and an example rotor 1130b. FIG. 4C shows a cross-sectional end view 1100c of an example stator 1105c that includes an example tubular housing 1110c, an example elastomer layer 1115c, an example conductive sub-layer 1122c, an example insulating layer 1124c, and an example rotor 1130c. FIG. 4D shows a cross-sectional end view 1100d of an example stator 1105d that includes an example tubular housing 1110d, an example elastomer layer 1115d, an example conductive sub-layer 1122d, an example insulating layer 1124d, and an example rotor 1130d. FIG. 4E shows a cross-sectional end view 1100e of an example stator 1105e that includes an example tubular housing 1110e, an example elastomer layer 1115e, an example conductive sub-layer 1122e, an example insulating layer 1124e, and an example rotor 1130e. FIG. 4F shows a cross-sectional end view 1100f of an example stator 1105f that includes an example tubular housing 1110f, an example elastomer layer 1115f, an example conductive sub-layer 1122f, an example insulating layer 1124f, and an example rotor 1130f.

[0036] FIG. 5 is a view of another example stator 500 that includes a substantially straight insulated conductive strip. In the illustrated example, the stator 500 includes a tubular housing 510 and a conductive strip layer 522. Although one conductive strip layer is described in this example, in some embodiments, two, three, four, or any other appropriate number of conductive strip layers may be used.

[0037] The conductive strip layer 522 is arranged substantially parallel to the longitudinal geometry of the inner surface of the insulating sub-layer 524a. The conductive strip layer 522 is electrically insulated from the tubular housing 510 by the insulating sub-layer 524a, and is electrically insulated from the bore of the stator 500 by an insulating sub-layer 524b. The conductive strip layer may take a helical form in the bore of the housing or may be of other regular or irregular geometry.

[0038] FIGs. 6A - 6B are cross-sectional views of an example stator 400 that includes multiple insulated conductors. In the illustrated example, the stator 400 includes a tubular housing 410 and two conductive layers 422a and 422b. Although two conductive layers are described in this example, in some embodiments, three, four, or any other appropriate number of conductive layers may be used.

[0039] The conductive layers 422a-422b are concentric layers formed to substantially conform to the geometry of the inner surface of the tubular housing 410. The conductive layer 420a is separated from the tubular housing 410 by an insulating sub-layer 424a. The conductive layers 422a-422b are separated by the insulating sub-layers 424b of FIG. 3C, and the conductive layer 422b is electrically insulated from the bore of the stator 400 by an insulating sub-layer 424c.

[0040] FIG. 7 illustrates a conceptual example implementation 800 of the example stator 300. In the illustrated example, a first electrical device (electrical power or data generator) 810 is electrically connected to a second electrical device (electrical power consumer or data receiver) 820

by the conductive sub-layer 322 of the stator 300. The first and second electrical devices 810, 820 may be, for example, an electricity generating dynamo and electro-mechanical actuator (e.g. a downhole drilling component such as an adjustable gauge stabilizer, traction device or a packer), or a digital data transmitter and digital data acquisition component. Each electrical device 810, 820 may include electronic components such as logic circuits, integrated circuits, and memory, optionally governed by firmware or other computer usable code for electronically controlling operation of the electrical devices 810, 820. The first electrical device 810 is connected to the conductive sub-layer 322 at a first end 830 of the stator 300, and the second electrical device 820 is connected to the conductive sub-layer 322 at a second end 840 of the stator 300. The conductive sub-layer 322 provides an electrical pathway between the first end 830 and the second end 840 of the stator 300, to facilitate electrical communication between the first electrical device 810 and the second electrical device 820. The insulating sub-layers 324a, 324b provide electrical insulation for the conductive sub-layer 322. In some implementations, the first electrical device 810 and/or the second electrical device 820 can be a source of electrical energy, a consumer of electrical energy, a passive or active component receiving an electrical signal (e.g. data signal), an electrical ground, or combinations of these and/or other appropriate electrical components. The electric current being conducted from electrical device 810 through a first electrical end conductor 811 to the conductive sub layer 322 may include an electrical

signal being transmitted and/or electrical power being conducted. For example, the first electrical device 810 can provide an electrical signal via a first end conductor 811 to the first end 830, and the signal can be transmitted along the conductive sub-layer 322 to the second end 840 or alternatively instead of a signal, electrical power may be conducted through the conductive sub layer and used to power a device in the tool string. Electric current is received from the electrically conductive layer at a second end 840 and may be transmitted via a second end conductor 821 . For example, the second electrical device 820 is connected via second end conductor 821 to the conductive sub-layer 322 to receive the signal that has been transmitted from the first electrical device 810 or alternatively receive the electrical power conducted through the conductive layer. It will be appreciated that a signal or power may be transmitted in either direction through the conductive layer. It will be appreciated that the electrical end conductor 811 and 821 may be any conductive device (e.g. a simple wire or a male/female type electrical coupler).

[0041] The implementation 800 can provide efficient and reliable electronic power and/or data transmission through downhole tools and/or drill strings. Power and/or data can be conducted through insulated conducting sleeves, e.g., the conductive sub-layer 322 and the insulating sub-layers 324a, 324b, which can form a solid part of drilling equipment cylindrical tubular components such as the stator 300. In some implementations, the stator 300 may provide electrical connectivity without significantly impacting the physical operational integrity of the drilling equipment

components, e.g., the cross-sectional geometry of the stator 300 may not be significantly impacted by the inclusion of the conductive sub-layer 322 and the insulating sub-layers 324a, 324b. In some implementations, adverse drilling fluid erosion, corrosion, vibration, and/or shock loading effects on the conductor may be reduced. For example, the flow of fluid through the bore of the stator 300 may be substantially unaffected by the presence of the conductive sub-layer 322 and the insulating sub-layers 324a, 324b, since the bore of the stator 300 can be formed with an inner surface geometry that is similar to stators not having insulated conducting sleeves, such as the example drill string 20 of FIGs. 2A-2B.

[0042] FIGs 8 and 8A are cross-sectional side views of an example stator 705 and example rotor 730 of an example downhole drilling motor 700. The stator 705 includes a tubular housing 710 (e.g. metal housing). In some embodiments, an additional helically lobed metal insert 715 is inserted into housing 710 or a helical lobe form is produced directly on the bore of housing 710. Then an insulated layer 720 is first applied to the inner surface of insert 720 or alternatively to the bore of the housing 710, then the conductor layer 722 is applied and then the elastomer sub layer 724 is applied. Fig 8A is an enlarged portion of Fig 8 and illustrates these applied layers.

[0043] The conductive sub-layer 722 is formed along the complex inner surface of the insulated layer 720 which is applied to the metal insert layer 715 (or alternatively the bore of the housing 210). In some embodiments, the conductive sub-layer 722 may be an electrically conductive sleeve or

strip that is inserted or otherwise applied to the inner surface of the elastomer layer 715. In some embodiments, the conductive sub-layer 722 may be a fluid or particulate compound that is sprayed, coated, or otherwise deposited upon the inner surface of the metal insert layer 715.

[0044] The insulating sub-layer 724 is formed along the concentric inward surface of the conductive sub-layer 722. The insulating sub-layer 724 may be polymeric and therefore deformable when the rotor is rotated inside the stator assembly. The insulating sub-layer 724 can protect the conductive sub-layer 722 from the erosive and abrasive conditions that may be present within the bore, e.g., wear from contact with the rotor 730, wear from mud or other fluid flows, chemical degradation due to substances carried by mud or fluid flows. In some embodiments, the insulating sub-layer 724 can be molded, sprayed, or otherwise take the form of a protective sleeve. In some embodiments, the insulating sub-layer 724 may implement nano-particle technology, and/or may be thin, e.g., a fraction of a millimeter to several millimeters thick. In some embodiments, the insulating sub-layer 724 may provide anti-erosion, anti-abrasion properties, and/or electrical insulating properties.

[0045] In some embodiments, the elastomer layer 720 applied to metal layer 715 can provide electrical insulation. For example, the elastomer layer 720 applied on metal layer 715 may also perform the function of an insulating sub-layer between the conductive sub-layer 722 and the tubular housing 710.

[0046] FIG. 9A is a cross-sectional view of an example sectional stator 1500. The stator 1500 includes a tubular housing 1510 and a collection of stator sections 1570. As shown in FIG. 9B, each stator section 1570 of the stator 1500 includes a metal insert layer 1522. In some embodiments, the insert layer 1522 can be an elastomer layer.

[0047] A conductive sub-section 1526a and a conductive sub-section 1526b are formed within a portion of the insert layer 1522. In some embodiments, the conductive sub-sections 1526a, 1526b may be electrically conductive sleeves or plugs that are inserted or otherwise applied to sub-sections of the insert layer 1522.

[0048] In some embodiments, the insert layer 1522 can provide electrical insulation. For example, the insert layer 1522 may also perform the function of an insulating sub-layer between the conductive sub-sections 1526a, 1526b and the tubular housing 1510.

[0049] Referring again to FIG. 9A, the stator 1500 includes a collection of the stator sections 1570, arranged as a lateral stack or row transverse to the longitudinal axis of the stator 1500 along the interior of the tubular housing 1510. The stator sections 1570 are oriented such that the conductive sub-sections 1526a, 1526b substantially align and make electrical contact with each other to provide insulated electrically conductive paths along the length of the stator 1500.

[0050] In some embodiments, the conductive sub-sections 1526a, 1526b may be replaced by open, e.g., unfilled, sub-sections. For example, the stator sections 1570 can be oriented such that the open sub-sections

substantially align and form a bore along the length of the stator 1500. In some embodiments, one or more conductive wires or laminated conductive sleeves may be passed through the bore formed by the open sub-sections.

[0051] FIG. 10 is an end view of another example stator section 1670 of an example stator 1600. In some implementations, the stator section 1670 may be used in place of the stator sections 1570 of FIG. 12A. The stator section 1670 includes a metal insert layer 1622. In some embodiments, the insert layer 1622 can be the elastomer layer. In some applications the disc or plate type stacked metal inserts 1622 are steel. They have an internal lobed geometry to which a thin layer of elastomer 1624 is applied. In other implementations, an insulated layer will first be applied to the internal lobed profile of the stacked metal inserts 1622, then there is a conductor layer or strip, then there is a final elastomer layer (the final layer being similar to the currently applied thin elastomer layer on stators).

[0052] A conductive sub-section 1626a and a conductive sub-section 1626b are formed within a portion of the elastomer layer 1622. In some embodiments, the conductive sub-sections 1626a, 1626b may be electrically conductive sleeves or plugs that are inserted or otherwise applied to sub-sections of the elastomer layer 1622.

[0053] In some embodiments, the conductive sub-sections 1626a, 1626b can include one or more electrically insulating and/or conductive sub-layers. For example the conductive sub-sections 1626a, 1626b may each include an electrically conductive sub-layer surrounded by an electrically

insulating sub-layer, e.g., to prevent the electrically conductive sub-layer from shorting out to the tubular housing 1610. In some embodiments, the conductive sub-sections 1626a, 1626b may be replaced by open, e.g., unfilled, sub-sections. For example, one or more electrical conductors may be passed through the open subsections to provide an electrical signal path along the length of the stator 1600

[0054] In some implementations, the stators 300, 400, 500, 600, 705, 905, 1005 and/or 1105a-1 105f may be used in conjunction with existing threaded connection conductor couplings, e.g., ring type couplings which fit between a pin connection nose and a box connection bore back upon tubular component assembly, to permit electronic signal and data to travel between components located along a drill string

[0055] FIG. 11 is a flow diagram of an example process 1200 for using a stator that includes an insulated conductor. In some implementations, the process 1200 may describe and/or be performed by any of the example stators 300, 400, 500, 600, 705, 905, 1005 and/or 1105a-1 105f.

[0056] At 1205, an outer housing is provided. For example, in the example of FIG. 3A to 3F, the tubular housing 310 is provided.

[0057] At 1210, a first protective layer is provided. For example, the insulating sub-layer 324a is formed as an inwardly concentric layer upon the tubular housing 310.

[0058] At 1215, an electrically conductive layer is provided. For example, the conductive sub-layer 322 is formed along the interior surface of the insulating sub-layer 324a.

[0059] At 1220, a second protective layer is provided. For example, the insulating sub-layer 324b is formed as an inwardly concentric layer upon the conductive sub-layer 322.

[0060] At 1225, electric current is applied to the electrically conductive layer at a first end. For example, electrical power from the first electrical device 810 is applied to the conductive sub-layer 322 at the first end 830.

[0061] At 1230, electric current is flowed along the electrically conductive layer. The electric current may include an electrical signal being transmitted and/or an electrical power being conducted. For example, the first electrical device 810 can provide an electrical signal to the first end 830, and the signal can be transmitted along the conductive sub-layer 322 to the second end 840 or alternatively instead of a signal, electrical power may be conducted through the conductive sub layer and used to power a device in the tool string (see Fig 7 and text describing Fig 7).

[0062] At 1235, electric current is received from the electrically conductive layer at a second end. For example, the second electrical device 820 is connected to the conductive sub-layer 322 to receive the signal that has been transmitted from the first electrical device 810 or alternatively receive the electrical power conducted through the conductive layer. It will be appreciated that a signal may be transmitted in either directions through

the conductive layer and electrical power may be transmitted in either direction through the conductive layer (see Fig 7 and text describing Fig 7) [0063] Although a few implementations have been described in detail above, other modifications are possible. For example, the logic flows depicted in the figures do not require the particular order shown, or sequential order, to achieve desirable results. In addition, other steps may be provided, or steps may be eliminated, from the described flows, and other components may be added to, or removed from, the described systems. Accordingly, other implementations are within the scope of the following claims.

WHAT IS CLAIMED IS:

1. A downhole drilling tool for well drilling operations, the downhole drilling tool comprising:

a tubular housing having a first longitudinal end and a second longitudinal end;

a stator disposed in the tubular housing, said stator defining an internal cavity passing there through, wherein the stator includes a first protective electrically insulated layer, a second protective electrically insulated layer, and at least one electrically conductive layer disposed between the first and second protective layers, said electrically conductive layer electrically coupled at a first end to a first electrical end conductor disposed proximal to the first longitudinal end of the tubular housing and electrically coupled at a second end to a second electrical end conductor disposed proximal to the second longitudinal end of the tubular housing; and

a rotor operatively positioned in the internal cavity to cooperate with the stator.

2. The tool of claim 1 wherein the first electric end conductor is electrically coupled to a first electrical device comprising an electric power generator and the second end conductor is electrically coupled to a second electrical device that comprises an electrical power consumer.

3. The tool of claim 1 wherein the first electric end conductor is electrically coupled to a first electrical device comprising a data generating device and

the second end conductor is electrically coupled to a second electrical device that comprises a data receiver.

4. The tool of any of claims 1 to 3 wherein the first end conductor is in electronic communication with the second end conductor via the at least one conductive layer disposed in the stator.

5. The tool of claim 1 wherein a signal from a first device received at the first end conductor is transmitted to the second end conductor via the at least one conductive layer disposed in the stator.

6. The tool of claim 1 wherein a signal from a second device is received at the second end conductor and is transmitted to the first end conductor layer via the at least one conductive layer disposed in the stator.

7. The tool of claim 1 wherein an electrical current received at the first end conductor is conducted to the second end conductor via at least one conductive layer disposed in the stator.

8. The tool of claim 1 wherein an electric current received at the second end conductor is conducted to the first end conductor via the at least one conductive layer disposed in the stator.

9. The tool of any of claims 1 to 8, wherein the first protective electrically insulated layer is disposed along an inner surface of the tubular housing, the electrically conductive layer is disposed along an inner surface of the

first protective layer, and the second protective electrically insulated layer is disposed along an inner surface of the electrically conductive layer.

10. The tool of claims 1 to 9, wherein at least one of the first protective electrically insulated layer and the second protective electrically insulated layer is electrically non-conductive.

11. The tool of any of claims 1 to 10, wherein the electrically conductive layer comprises a first electrically conductive layer and said tool further comprises a second electrically conductive layer that is electrically insulated from the first electrically conductive layer.

12. The tool of claim 11, wherein the second electrically conductive layer is disposed along an inner surface of the second protective layer, and a third protective electrically insulated layer is disposed along an inner surface of the second electrically conductive layer.

13. The tool of any of claims 1 to 12, wherein the inner surface of the first protective electrically insulated layer comprises a curved inner surface with a circumference, and the electrically conductive layer is disposed about less than the entire circumference of the curved inner surface of the first protective layer.

14. The tool of any of claims 1 to 13 wherein the electrically conductive layer is disposed in a strip generally parallel to a longitudinal axis of the housing.

15. The tool of any of claims 1 to 13 wherein the electrically conductive layer is disposed a helical arrangement in the bore of the housing.
16. The tool of claim 11, wherein the second electrically conductive layer is disposed parallel to the first electrically conductive layer.
17. The tool of any of claims 1 to 13, wherein the stator further comprises a plurality of lateral layers of stator sections including at least one conductive subsection in each layer, said conductive sub section aligned with a conductive subsection in an adjacent stator section and each said conductive sub section is coupled electrically to an adjacent conductive sub section.
18. The tool of claim 17 wherein the conductive sub section comprises a conductive sleeve disposed in the conductive sub section.
19. The tool of claim 18 wherein the conductive sub section comprises a conductive plug disposed in the conductive sub section.
20. The tool of any of claims 1 to 8, wherein the stator further comprises a plurality of lateral layers of stator sections including at least one opening in each layer, said opening aligned with an opening in an adjacent stator section to form a continuous passage through the stator.
21. The tool of claim 20 wherein an electrical conductor is disposed in the continuous passage in the stator.

22. The tool of any of claims 1 to 8 wherein the stator further comprises an insert layer disposed longitudinally and adjacent to an interior surface of the tubular housing.

23. The tool of claims 22 wherein the insert layer is metallic.

24. The tool of claim 22 wherein the insert layer is formed from a polymeric material.

25. The tool of claim 22 wherein the insert layer is formed integrally with the tubular housing to form a bore to which the first protective layer is applied.

26. A method of conducting electricity in a well drilling operation, the method comprising:

providing a downhole drilling tool, the tool including:

a tubular housing having a first longitudinal end and a second longitudinal end,

a stator disposed in the tubular housing, said stator defining an internal cavity passing there through, wherein the stator includes a first protective electrically insulated layer, a second protective electrically insulated layer, and an electrically conductive layer disposed between the first and second protective electrically insulated layers, said electrically conductive layer coupled at a first end to a first electrical end conductor disposed proximal to the first longitudinal end of the tubular housing and

coupled at a second end to a second electrical end conductor disposed proximal to the second longitudinal end of the tubular housing, and

a rotor operatively positioned in the internal cavity to cooperate the stator;

providing electrical current to the conductive layer to the first electrical end conductor located proximal to the first longitudinal end;

conducting the electrical current along the conductive layer from the first longitudinal end of the housing to the second longitudinal end of the housing; and

receiving the electrical current from the conductive layer at the second electrical end conductor located proximal to the second longitudinal end of the housing.

27. The method of claim 26 further comprising electrically coupling to the first electrical end conductor a first electrical device comprising an electrical power generator and electrically coupling to the second end conductor a second electrical device comprising a power consumer.

28. The method of claim 26 further comprising electrically coupling to the first electrical end conductor a first electrical device comprising a data generator and coupling to the second end conductor a second electrical device comprising a data receiver.

29. The method of claim 26 wherein providing the electrical current at the first end conductor comprises providing a signal from a first device and receiving electrical current at the second end conductor comprises

receiving the signal from the first device, and said method further comprises transmitting the signal from the second end conductor to a second device.

30. The method of claim 26 wherein providing the electrical current at the first end conductor comprises providing electrical power and receiving electrical current at the second end comprises receiving electrical power, and said method further comprises conducting the electrical power from the second end conductor to a device using the electrical power.

31. The method of claim 26 further including reversing the flow of electrical current and providing electrical current at the second conductor, conducting the electrical current along the conductive layer, and receiving electric current at the first end conductor.

32. A downhole drilling tool for well drilling operations, the downhole drilling tool comprising:

a tubular housing having a first longitudinal end and a second longitudinal end; and

a rotatable or reciprocating member disposed in the tubular housing, said rotatable or reciprocating member and said housing defining an internal cavity, wherein the housing includes a first protective electrically insulated layer, a second protective electrically insulated layer, and an electrically conductive layer disposed between the first and second protective layers, said electrically conductive layer electrically coupled at a

first end to a first electrical end conductor disposed proximal to the first longitudinal end of the tubular housing and electrically coupled at a second end to a second electrical end conductor disposed proximal to the second longitudinal end of the tubular housing.

33. The tool of claim 32 wherein the first electric end conductor is electrically coupled to a first electrical device comprising an electric power generator and the second end conductor is electrically coupled to a second electrical device that comprises an electrical power consumer.

34. The tool of claim 32 wherein the first electric end conductor is electrically coupled to a first electrical device comprising a data generating device and the second end conductor is electrically coupled to a second electrical device that comprises a data receiver.

35. The tool of any of claims 32 to 34 wherein the first end conductor is in electronic communication with the second end conductor via the at least one conductive layer disposed in the stator.

36. The tool of claim 32 wherein a signal from a first device received at the first end conductor is transmitted to the second end conductor via the at least one conductive layer disposed in the stator.

37. The tool of claim 32 wherein a signal from a second device is received at the second end conductor and is transmitted to the first end conductor layer via the at least one conductive layer disposed in the stator.

38. The tool of claim 32 wherein an electrical current received at the first end conductor is conducted to the second end conductor via at least one conductive layer disposed in the stator.

39. The tool of claim 32 wherein an electric current received at the second end conductor is conducted to the first end conductor via the at least one conductive layer disposed in the stator.

40. A method of conducting electricity in a well drilling operation, the method comprising:

providing a downhole drilling tool, the tool including

a tubular housing having a first longitudinal end and a second longitudinal end; and

wherein the housing includes a first protective electrically insulated layer, a second protective electrically insulated layer, and an electrically conductive layer disposed between the first and second protective layers, said electrically conductive layer coupled at a first end to a first electrical end conductor put disposed proximal to the first longitudinal end of the tubular housing and coupled at a second end to a second electrical end conductor disposed proximal to the second longitudinal end of the tubular housing;

providing electrical current to the conductive layer at the first electrical end conductor located proximal to the first longitudinal end;

conducting the electrical current along the conductive layer from the first longitudinal end of the housing to the second longitudinal end of the

housing; and

receiving the electrical current from the conductive layer at the second electrical end conductor located proximal to the second longitudinal end of the housing.

41. The method of claim 40 further comprising electrically coupling to the first electrical end conductor a first electrical device comprising an electrical power generator and electrically coupling at the second end conductor a second electrical device comprising a power consumer.

42. The method of claim 40 further comprising electrically coupling to the first electrical end conductor a first electrical device comprising a data generator and electrically coupling at the second end conductor a second electrical device comprising a data receiver

43. The method of claim 40 wherein providing the electrical current at the first end conductor comprises providing a signal from a first device and receiving electrical current at the second end conductor comprises receiving the signal from the first device, and said method further comprises transmitting the signal from the second end conductor to a second device.

44. The method of claim 40 wherein providing the electrical current at the first end conductor comprises providing electrical power and receiving electrical current at the second end comprises receiving electrical power,

and said method further comprises conducting the electrical power from the second end conductor to a device using the electrical power.

45. The method of claim 40 further including reversing the flow of electrical current and providing electrical current at the second conductor, conducting the electrical current along the conductive layer, and receiving electric current at the first end conductor.

46. The tool of any of claims 1-9 wherein the inner surface of the tubular housing is cylindrical.

47. The tool of any of claims 1-9 wherein the inner surface of the tubular housing is geometrically complex.

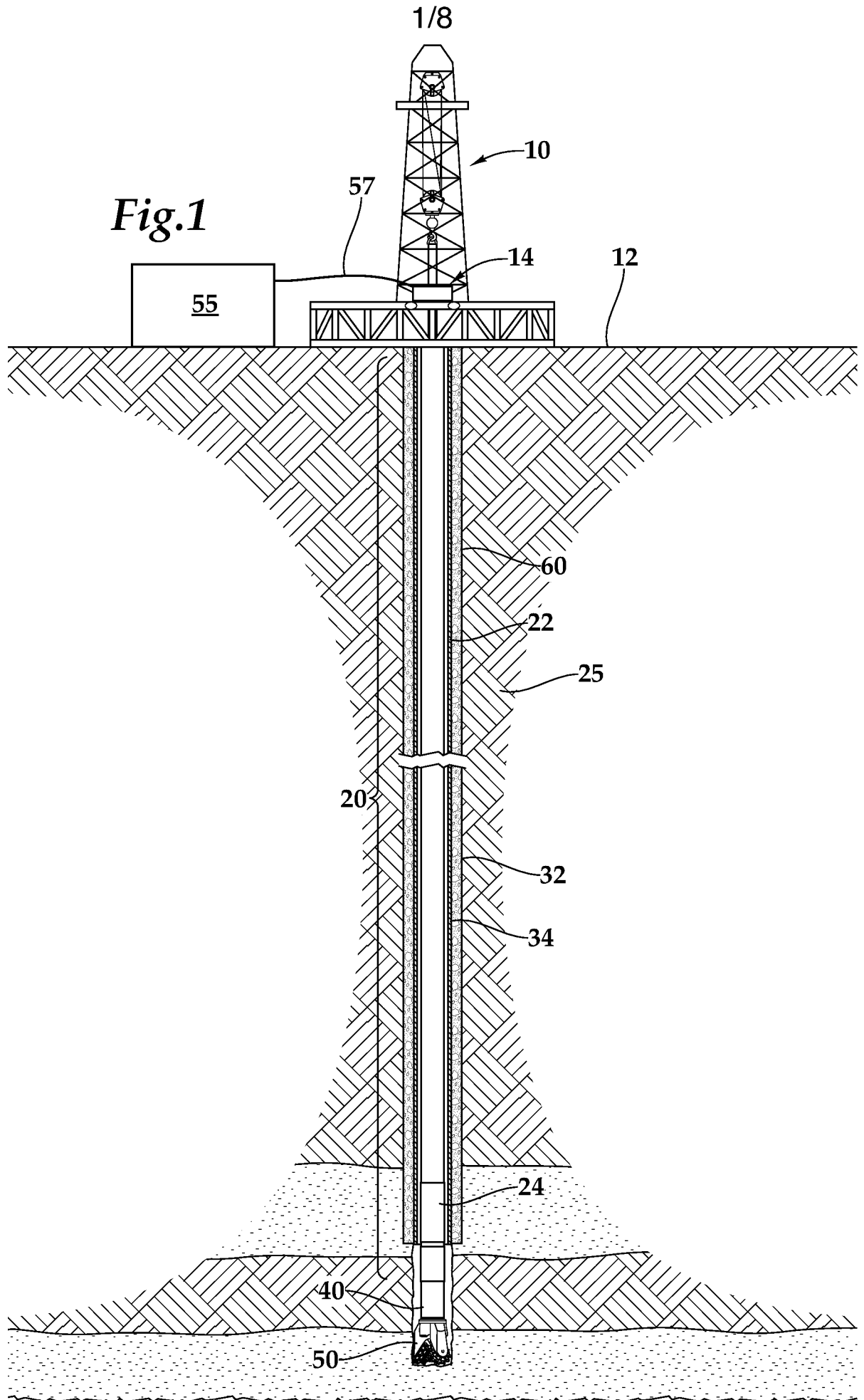

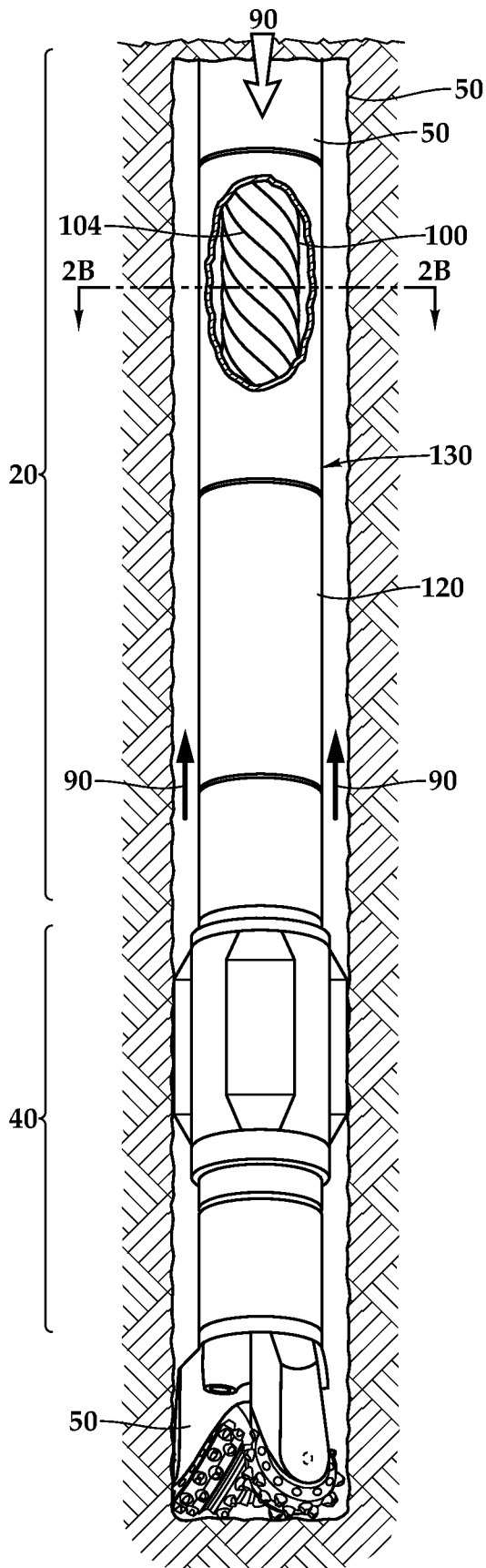

Fig.2A

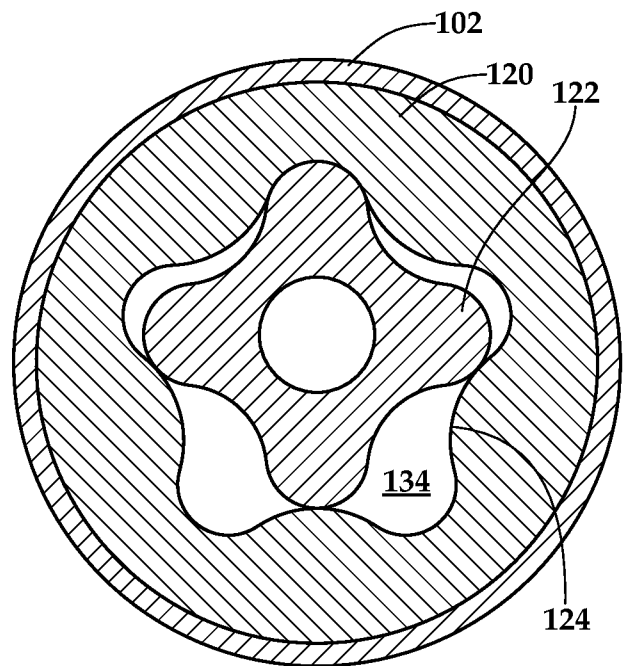

Fig.2B

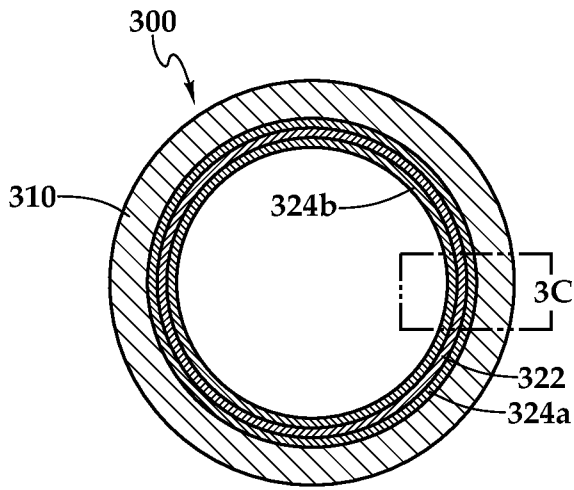

Fig.3A

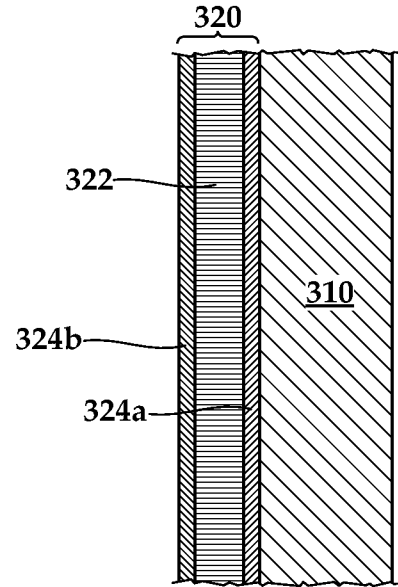

Fig.3C

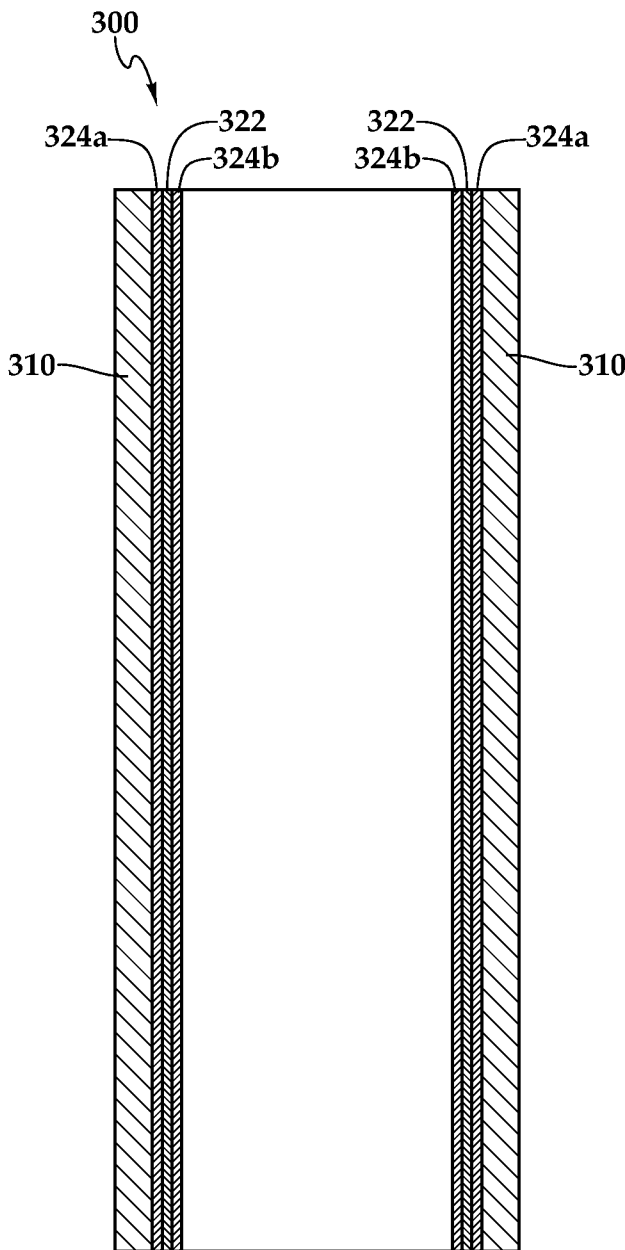

Fig.3B

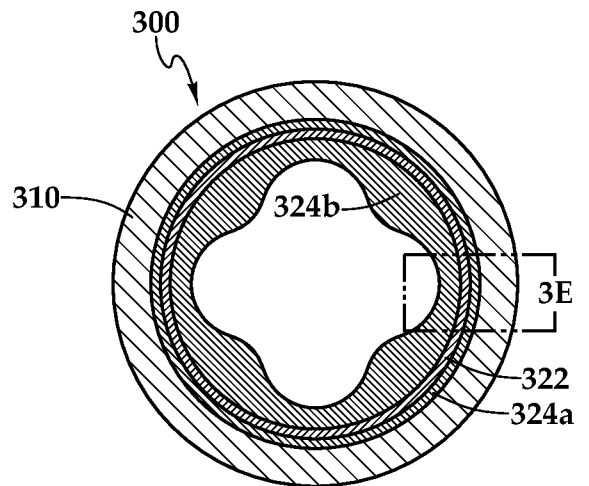

Fig.3D

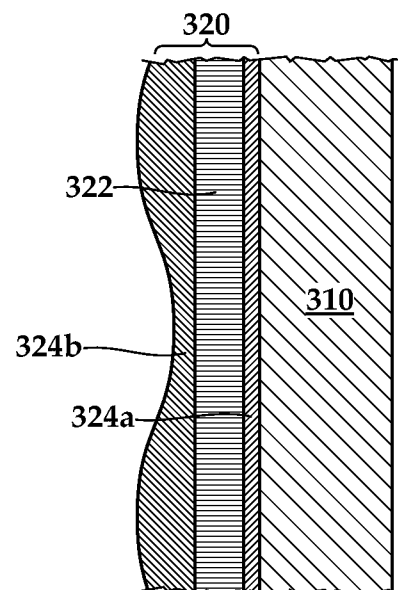

Fig.3E

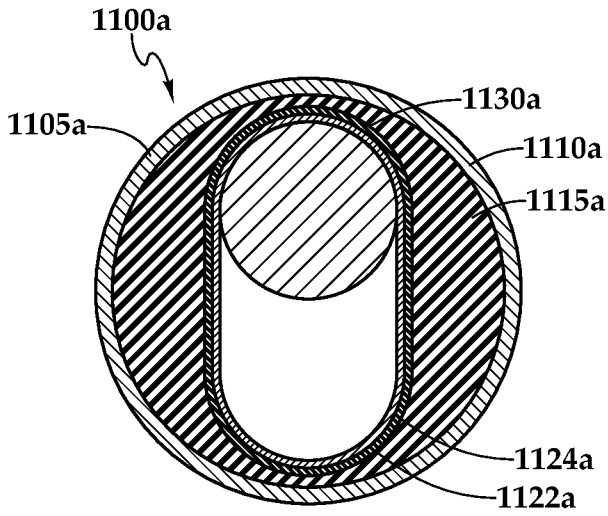

Fig. 4A

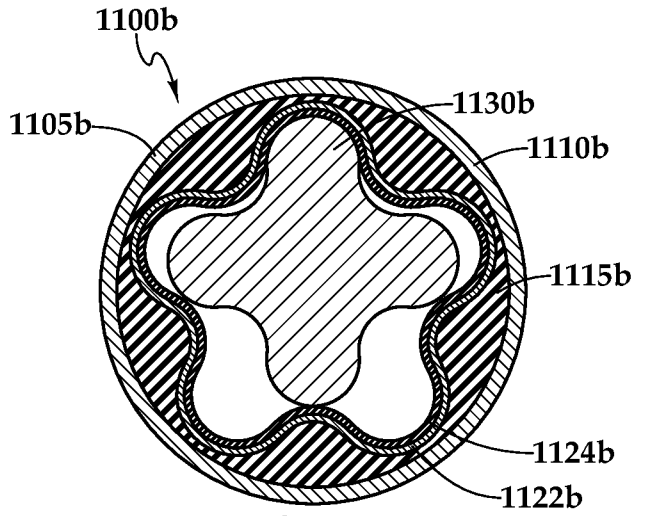

Fig. 4B

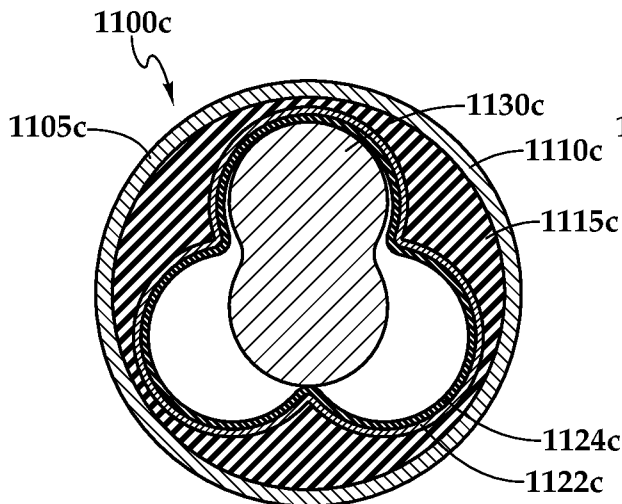

Fig. 4C

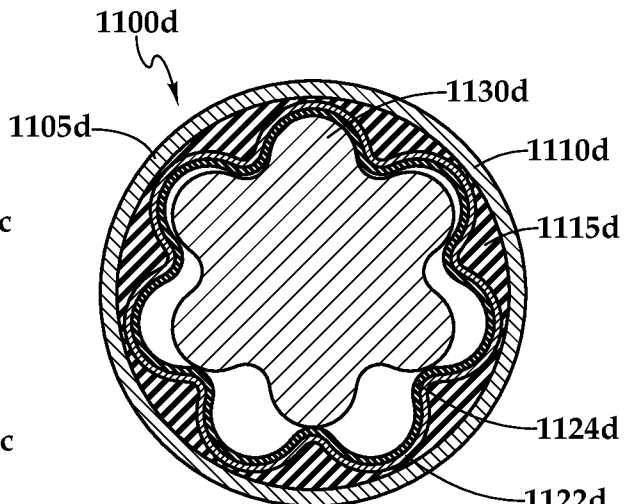

Fig. 4D

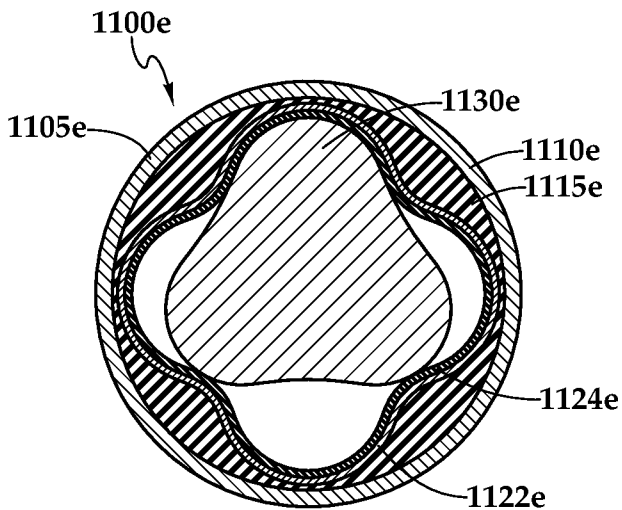

Fig. 4E

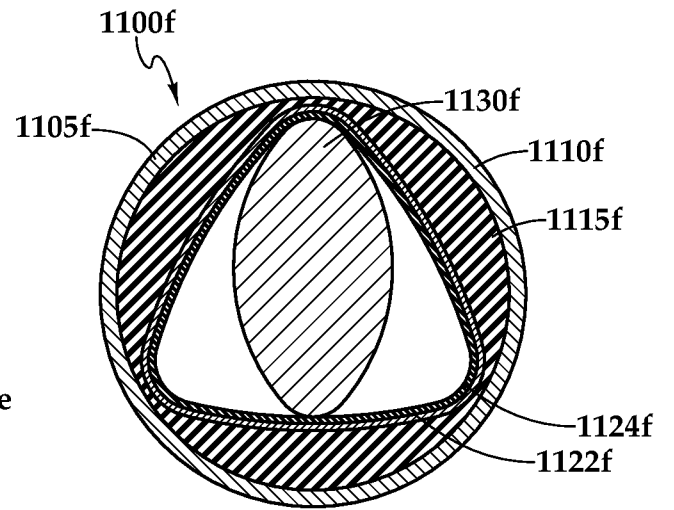

Fig. 4F

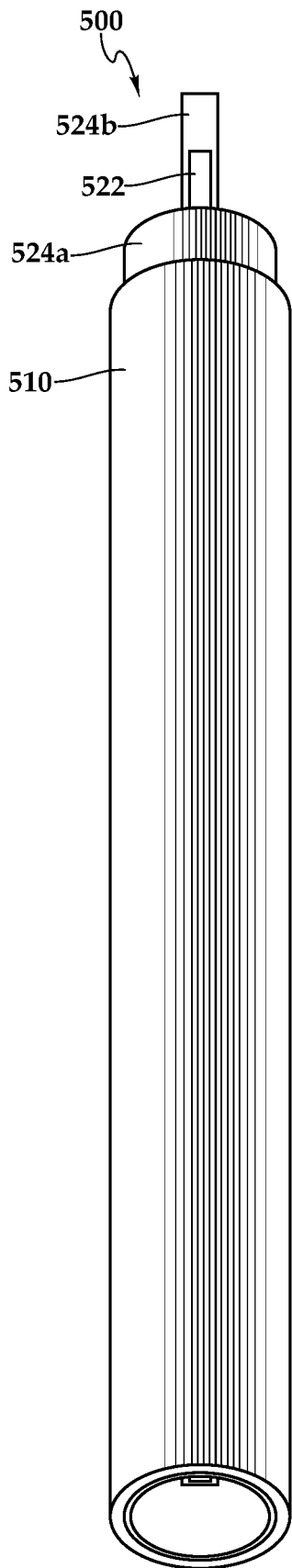

Fig. 5

5/8

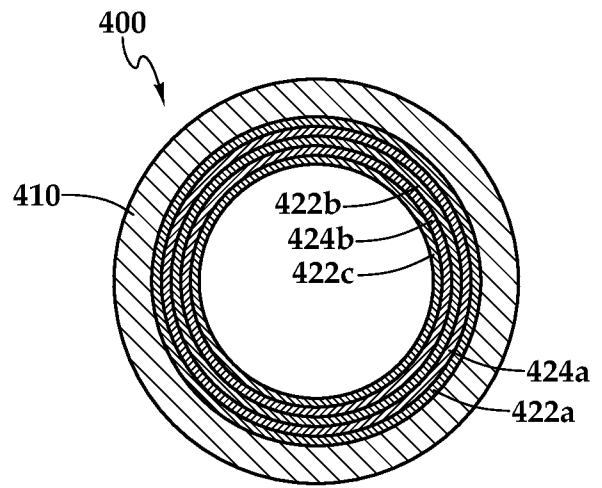

Fig. 6A

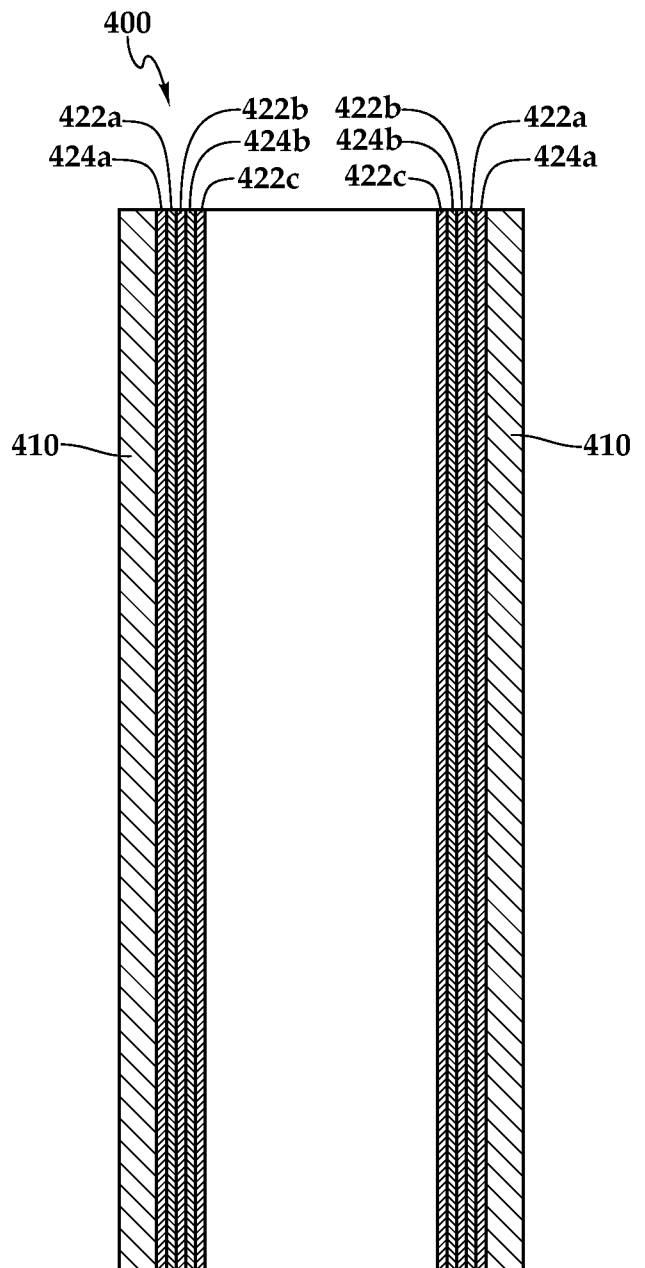

Fig. 6B

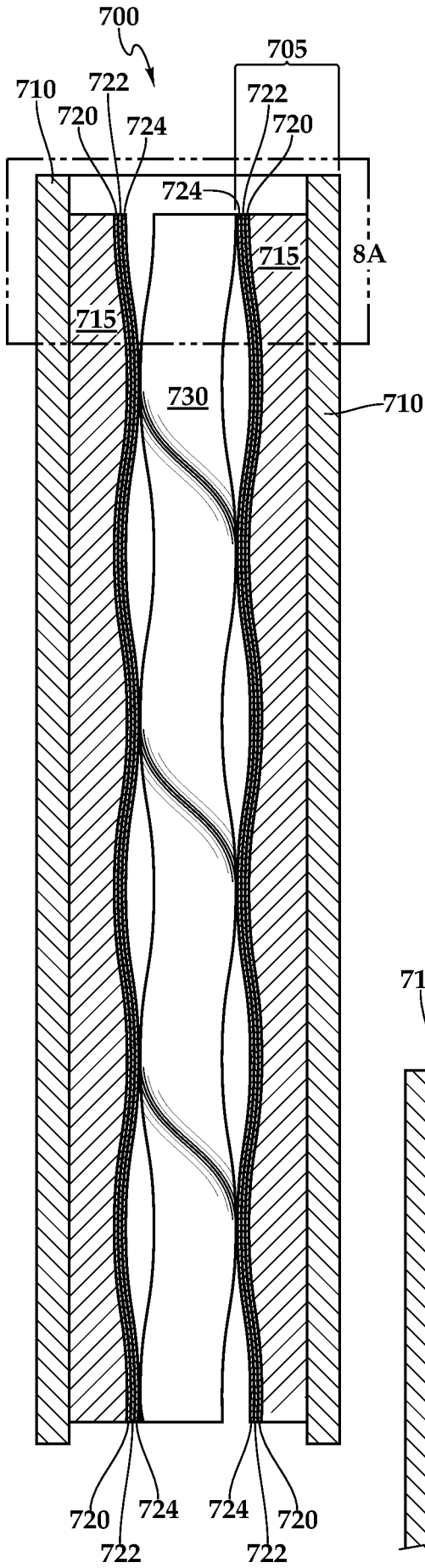

Fig. 8

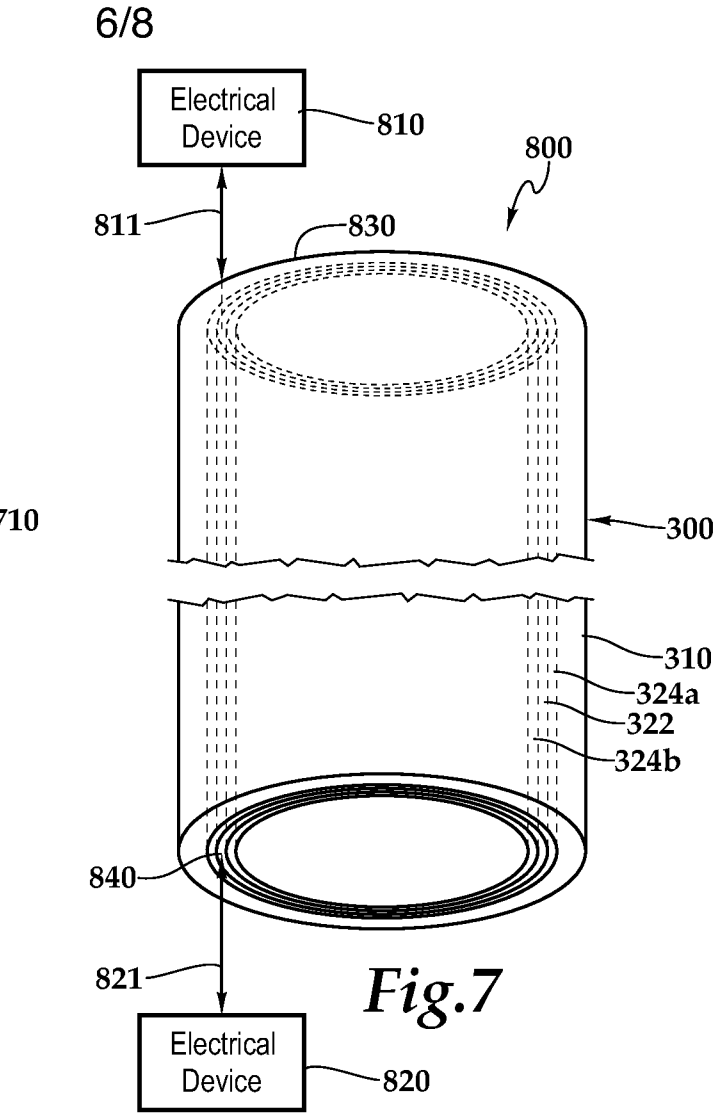

Fig. 7

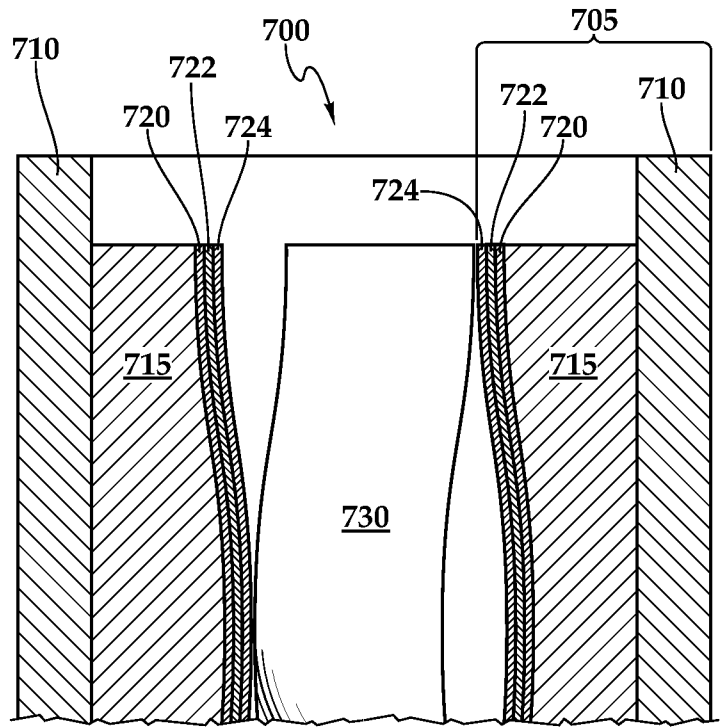

Fig. 8A

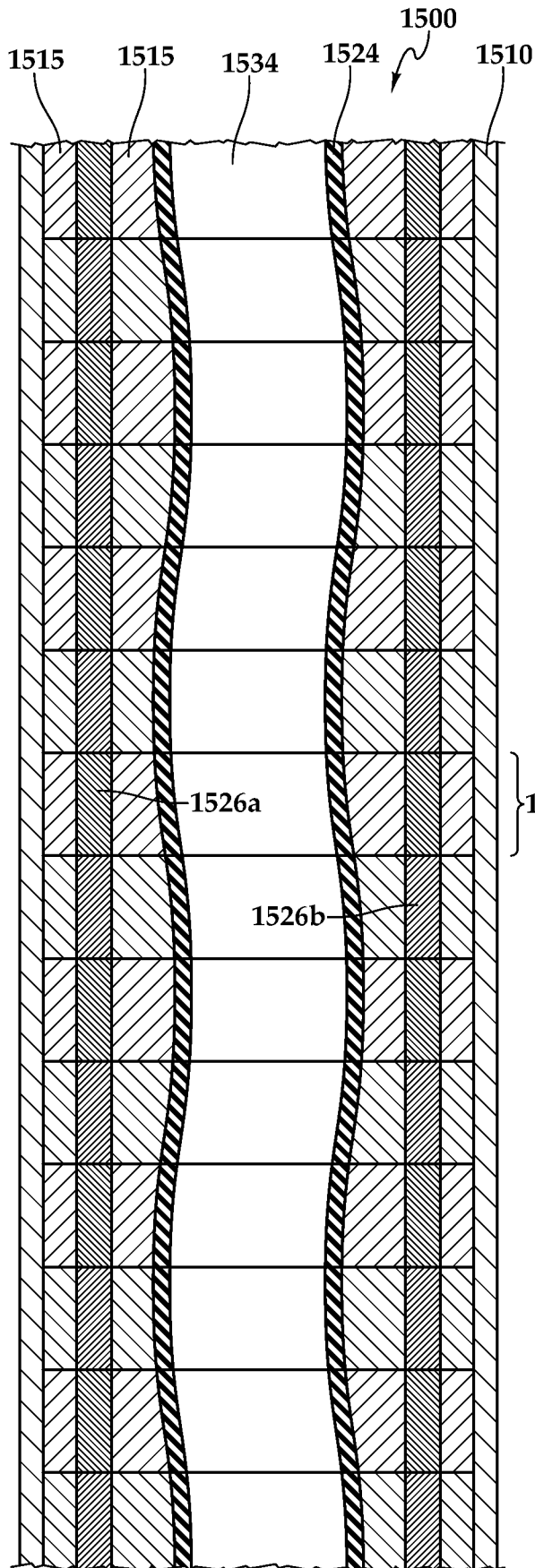

Fig.9A

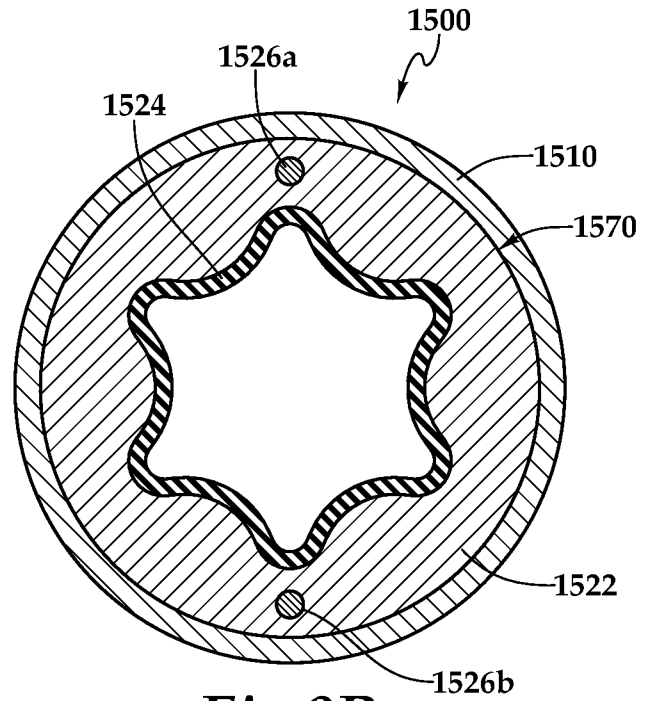

Fig.9B

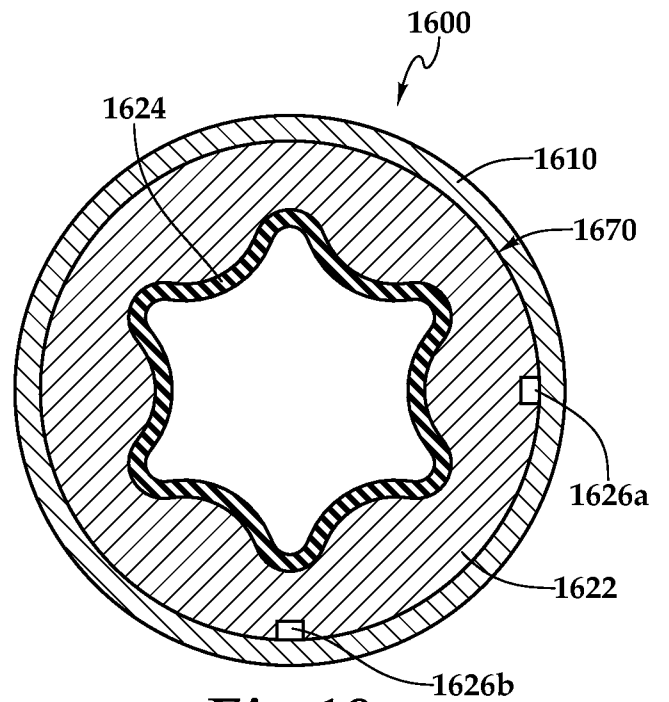

Fig.10

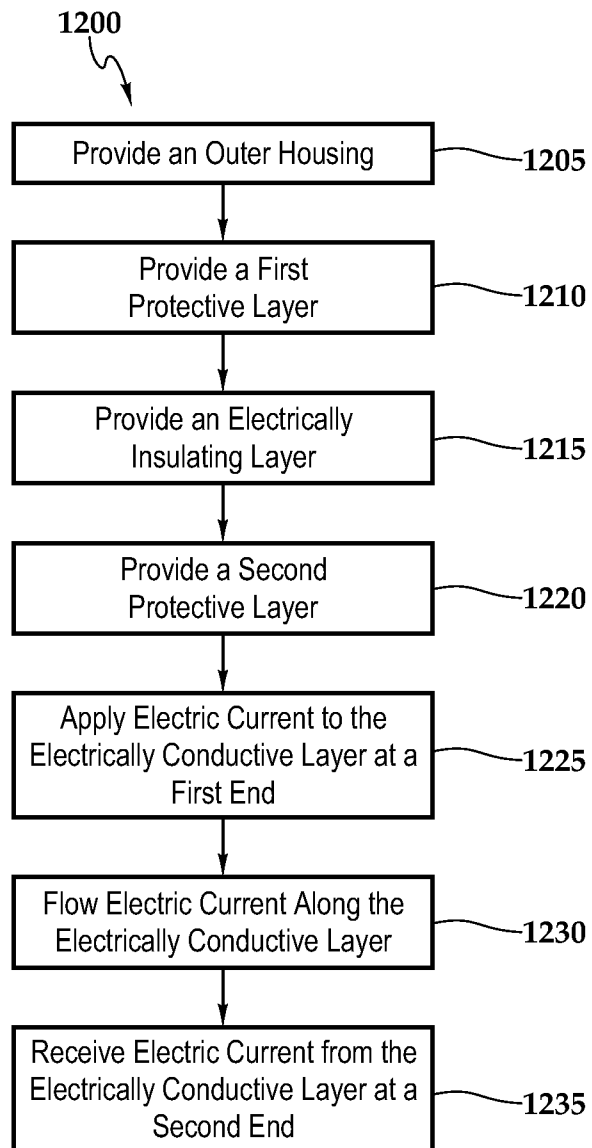

Fig.11

INTERNATIONAL SEARCH REPORT

International application No.
PCT/US20 13/040076**A. CLASSIFICATION OF SUBJECT MATTER****E21B 17/01(2006.01)i, E21B 4/06(2006.01)i, E21B 23/08(2006.01)i**

According to International Patent Classification (IPC) or to both national classification and IPC

B. FIELDS SEARCHED

Minimum documentation searched (classification system followed by classification symbols)

E21B 17/01; E21B 4/02; E21B 33/10; E21B 17/10; E21B 7/08; FOIC 1/107; B24D 18/00; F04C 29/02; E21B 4/06; E21B 23/08

Documentation searched other than minimum documentation to the extent that such documents are included in the fields searched
Korean utility models and applications for utility models
Japanese utility models and applications for utility modelsElectronic data base consulted during the international search (name of data base and, where practicable, search terms used)
eKOMPASS(KIPO internal) & keywords: stator, rotor, electrical insulation, conductive, and layer**C. DOCUMENTS CONSIDERED TO BE RELEVANT**

Category *	Citation of document, with indication, where appropriate, of the relevant passages	Relevant to claim No.
A	us 2009-0152009 AI (SLAY et al.) 18 June 2009 See abstr act , paragraph [0052] , and figure 1.	1-47
A	us 2006-0086536 AI (BOYLE et al.) 27 April 2006 See abstr act , paragraphs [0030]- [0031] , and figure 1.	1-47
A	us 2012-0018227 AI (PUZZ et al.) 26 January 2012 See abstr act , paragraphs [0027]- [0029] , and figures 1A-1B.	1-47
A	us 2012-0024632 AI (JOHN, HENDRIK) 02 February 2012 See abstr act , paragraphs [0011]- [0012] , and figure 1.	1-47
A	us 2013-0048384 AI (JARVIS et al.) 28 February 2013 See abstr act , paragraphs [0004]- [0006] , and figures 1-3 .	1-47



Further documents are listed in the continuation of Box C.



See patent family annex.

* Special categories of cited documents:

"A" document defining the general state of the art which is not considered to be of particular relevance

"E" earlier application or patent but published on or after the international filing date

"L" document which may throw doubts on priority claim(s) or which is cited to establish the publication date of another citation or other special reason (as specified)

"O" document referring to an oral disclosure, use, exhibition or other means

"P" document published prior to the international filing date but later than the priority date claimed

"T" later document published after the international filing date or priority date and not in conflict with the application but cited to understand the principle or theory underlying the invention

"X" document of particular relevance; the claimed invention cannot be considered novel or cannot be considered to involve an inventive step when the document is taken alone

"Y" document of particular relevance; the claimed invention cannot be considered to involve an inventive step when the document is combined with one or more other such documents, such combination being obvious to a person skilled in the art

"&" document member of the same patent family

Date of the actual completion of the international search

22 January 2014 (22.01.2014)

Date of mailing of the international search report

22 January 2014 (22.01.2014)

Name and mailing address of the ISA/KR

Korean Intellectual Property Office
189 Cheongsu-ro, Seo-gu, Daejeon Metropolitan City,
302_701 > Republic of Korea

Facsimile No. +82-42-472-7140

Authorized officer

LEE, Jong Kyung

Telephone No. +82-42-481-3360

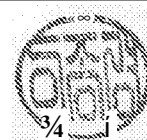

INTERNATIONAL SEARCH REPORT

Information on patent family members

International application No.

PCT/US2013/040076

Patent document cited in search report	Publication date	Patent family member(s)	Publication date
US 2009-0152009 AI	18/06/2009	AU 2008-343949 AI EP 2252768 A2 MX 2010006839 A US 2010-0038142 AI WO 2009-085112 A2 WO 2009-085112 A3	09/07/2009 24/11/2010 11/08/2010 18/02/2010 09/07/2009 27/08/2009
US 2006-0086536 AI	27/04/2006	CA 2524681 AI CA 2524681 C GB 0521808 DO GB 2419619 A NO 20054955 A NO 20054955 DO US 7168510 B2	27/04/2006 13/10/2009 07/12/2005 03/05/2006 28/04/2006 25/10/2005 30/01/2007
US 2012-0018227 AI	26/01/2012	CA 2806231 AI DE 112011102466 T5 GB 201301058 DO GB 2497215 A NO 20130138 A WO 2012-012754 AI	26/01/2012 25/04/2013 06/03/2013 05/06/2013 08/02/2013 26/01/2012
US 2012-0024632 AI	02/02/2012	CA 2806109 AI DE 112011102497 T5 GB 201301278 DO GB 2496541 A NO 20130119 A WO 2012-015927 A2 WO 2012-015927 A3	02/02/2012 29/05/2013 06/03/2013 15/05/2013 20/02/2013 02/02/2012 05/04/2012
US 2013-0048384 AI	28/02/2013	EP 2640921 A2 US 2012-0132470 AI WO 2012-068522 A2 WO 2012-068522 A3	25/09/2013 31/05/2012 24/05/2012 04/10/2012