

Oct. 25, 1949.

P. F. PETERSEN

2,486,060

EXPANSION VALVE

Filed Jan. 20, 1947

FIG 1

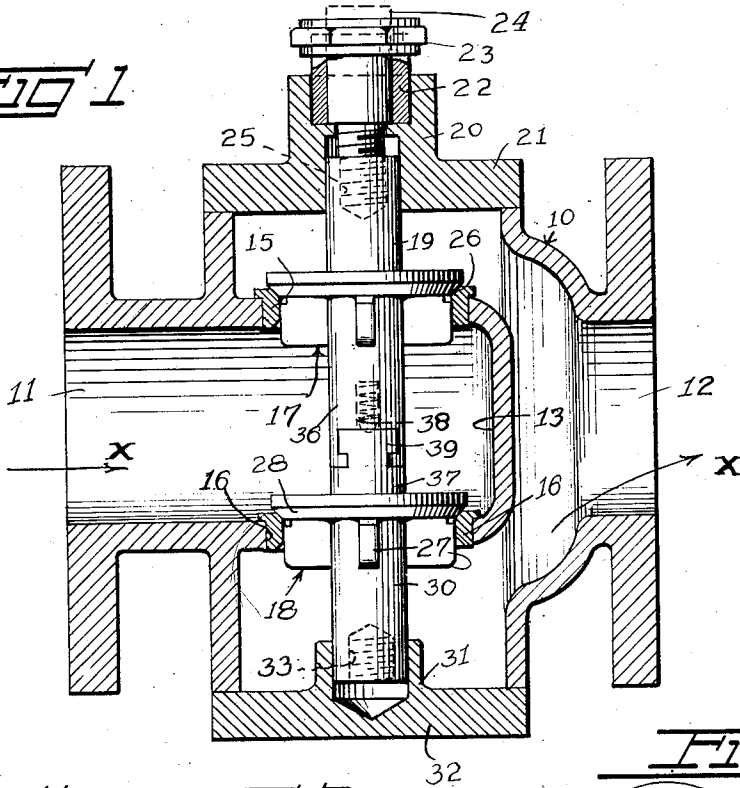

FIG 2

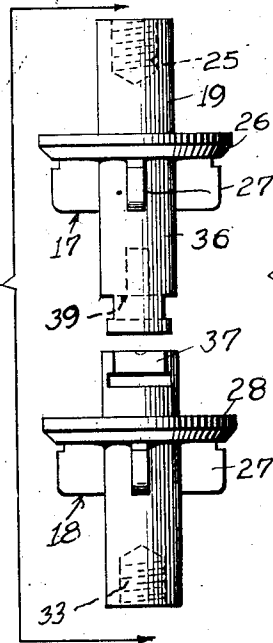

FIG 3

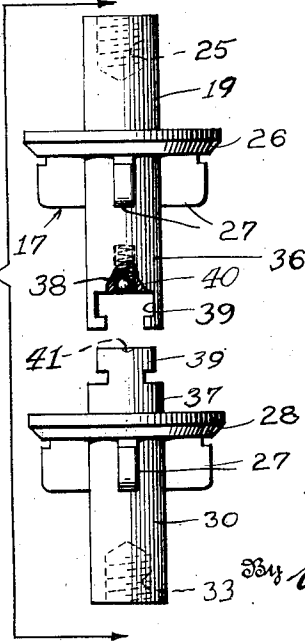

FIG 4

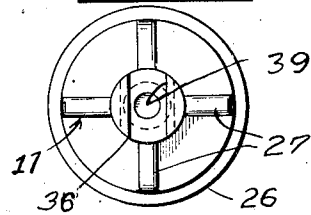
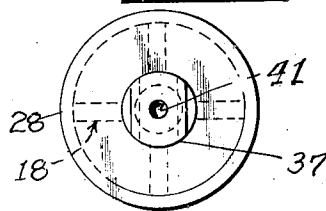

FIG 5



Inventor

Peter F. Petersen

By Wilfred Lawson

Attorney

UNITED STATES PATENT OFFICE

2,486,060

EXPANSION VALVE

Peter F. Petersen, Los Angeles, Calif.

Application January 20, 1947, Serial No. 723,067

3 Claims. (Cl. 251-82)

1

My invention relates to an expansion valve which is equally applicable to different kinds of fluids such as oil, water, gas and steam and this expansion valve can be made to fit any type double port valves. It is so constructed that it can give lift, and is none spinning and none chattering, when adjusted for correct flow of fluid. It can be made of any kind of suitable metal or plastic material. The valve will be used for reducing purposes as well as for back pressure.

One embodiment of this invention is illustrated in the drawing, wherein like numerals denote the same details in the different views.

Figure 1 is a vertical, sectional view of the valve body with double piston head seated therein;

Figure 2 is a side elevation of a double piston head with the two halves separated;

Figure 3 is a front elevation of the double piston head seen from the right side of Figure 2;

Figure 4 is a bottom plan view of the upper piston head;

Figure 5 is a top plan view of the bottom head of the double piston.

Numeral 10 denotes the valve body or casing having an injection port 11 for steam or other fluids and in alinement therewith an exhaust port 12. Between the two ports is formed a valve chamber 13, which communicates with both ports thru the top valve seat 15, and the bottom seat 16, each provided with suitable packing for the two valve heads 17 and 18.

The upper valve head 17 has a short shank 19 slidable in the boss 20 and projecting upwardly into a cap 21 secured in the usual manner as by bolts, on the top of the casing.

In said boss is inserted a sleeve 22 closed by a nut 23, for guiding the piston rod 24, for reciprocation of the piston top head 17 to which it is secured by threads as at 25.

The top head 17 has a round disk 26, with tapered bottom surfaces fitting accurately in the seat 15. From the cylindrical lower portion below the round disk project flat radial wings 27 which engage in corresponding grooves in the casing 10 in order to keep the top head 17 from turning.

The lower head 18 is provided with similar wings 27, having the same function, and which are located below the round, beveled disk 28, which engage in the seat 16, also having a suitable packing. This head 18 terminates on its under side with a shank 30, which engages in a boss 31 in the bottom cap 32. This shank 30 is also threaded as at 33, in the same manner, as the shank 19 on the top head 17. This for the

2

purpose, that the two heads may be exchanged if the valve is to be reversed for back pressure, instead of for reducing pressure as it is now arranged in Figure 1, where the fluid inlet is at the left end 11. In any event the piston rod 24 is threaded for attachment in either one of the shanks 19, or 30, but the caps have to be turned upside down, when exchanged.

Between the valve heads are shown two stems 36, 37, one on each valve head 17, 18. These stems terminate with an interengaging dove-tail 39, for holding the heads together. A small amount of play is provided between them and a compression spring 38 is carried in a recess in the top head stem 38 acting against a small ball 40, resting in a small recess 41 in the stem of the bottom head. In this manner a yielding connection is provided to insure constant seating of the two heads, even after wear occurs between the heads and their seats. This also prevents all chattering between the parts and the guide wings eliminate any spinning.

When this double valve is used for reducing pressure, the flow is from the left at 11 of Figure 1, and out to the right at 12, as indicated by arrows X. When used for back pressure the flow enters at 12 and leaves at 11.

It is to be understood that the invention as herein disclosed may be varied from the details described and shown without departure from the spirit of the subjoined claims.

I claim:

1. An expansion valve comprising a pair of valve heads joined in axial alignment, a casing for said valve heads, an inner chamber with a fluid inlet, an outer chamber with a fluid outlet in said casing, spaced coaxial seats for said heads between said chambers, said casing having opposite coaxial apertures of sufficient diameter to permit the placing of the heads on their seats from either of two directions, a cap provided for each aperture, means for securely fastening the caps to close said apertures, each head having a shank, a guide in each cap to slidably receive the shank of the adjacent head, a piston rod carried in a bearing in one of said caps, a threaded extension on the end of the rod, and each shank having a threaded socket adapted to receive said extension when the shank is in the guide of the said one of the caps.

2. A reversible valve comprising a casing having an inner chamber, a port forming a communication between the same and the outside of the casing and an outer chamber, and a port forming a communication between the same and the

3

outside of the casing, two spaced coaxial valve seats within the casing between said chambers, a pair of valve heads adapted to position on said seats, each of the heads having a stem, a coupling means between the stems of the two heads, each of the heads further having a shank upon the opposite end from the stem, each of said shanks having a threaded socket in the end thereof, said casing further having oppositely positioned coaxial openings coaxial with said seats, a cap removably positioned over each of said openings, one of said caps having a guide adapted to slidably receive a shank, the other cap having a corresponding guide for the reception of the other shank and extending through the cap, a bearing in the guide of the said other cap at the outer end of the guide, a piston rod slidably engaged in said bearing and a threaded shank extending axially from the inner end of the piston rod and adapted for selective threaded engagement in the threaded sockets of said valve shanks, the said caps being reversible for closing the casing openings.

3. A reversible valve of the character stated in claim 2 in which the connection between the

4

ends of the valve stems comprises a dove-tail formed across the end of one stem and a dove-tail slot formed across the end of the other stem to receive the dove-tail, the slot being formed to permit the dove-tail to have slight movement therein axially of the stems, one of the stems having a bore therein, a spring housed in said bore, and means interposed between the outer end of the spring and the end of the adjacent stem forming a bearing.

PETER F. PETERSEN.

REFERENCES CITED

The following references are of record in the file of this patent:

UNITED STATES PATENTS

Number	Name	Date
640,222	Price	Jan. 2, 1900
820,917	Culler	May 15, 1906
1,575,771	King	Mar. 9, 1926
2,019,193	Mueller	Oct. 29, 1935
2,184,793	Clench	Dec. 26, 1939