

April 9, 1929.

I. C. JORDAN

1,708,507

COAL PUSHER

Filed May 5, 1926

3 Sheets-Sheet 1

Fig. 1.

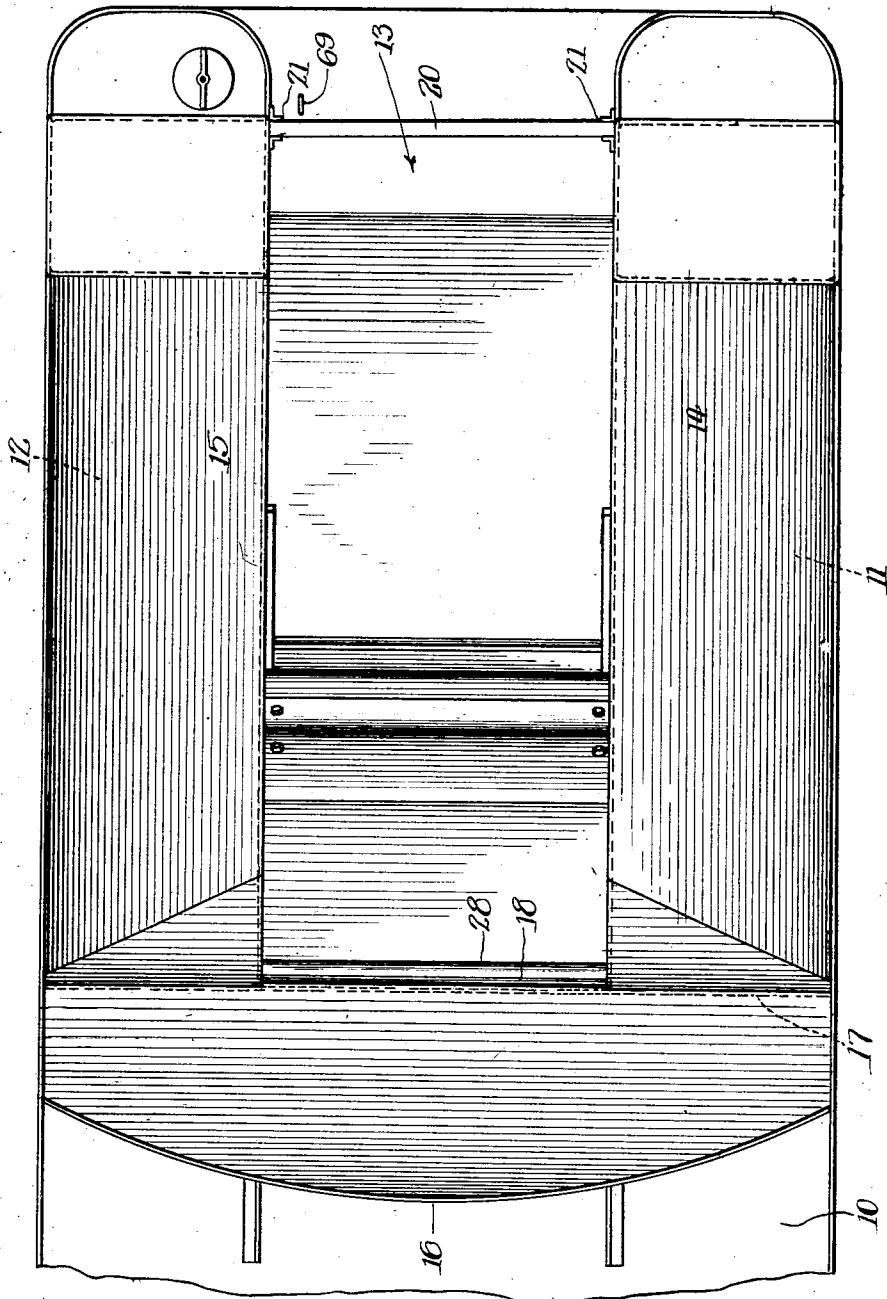

Inventor:
Ira C. Jordan,
By *Abundant, Parker & Carlson*
Attys.

April 9, 1929.

I. C. JORDAN

1,708,507

COAL PUSHER

Filed May 5, 1926

3 Sheets-Sheet 2

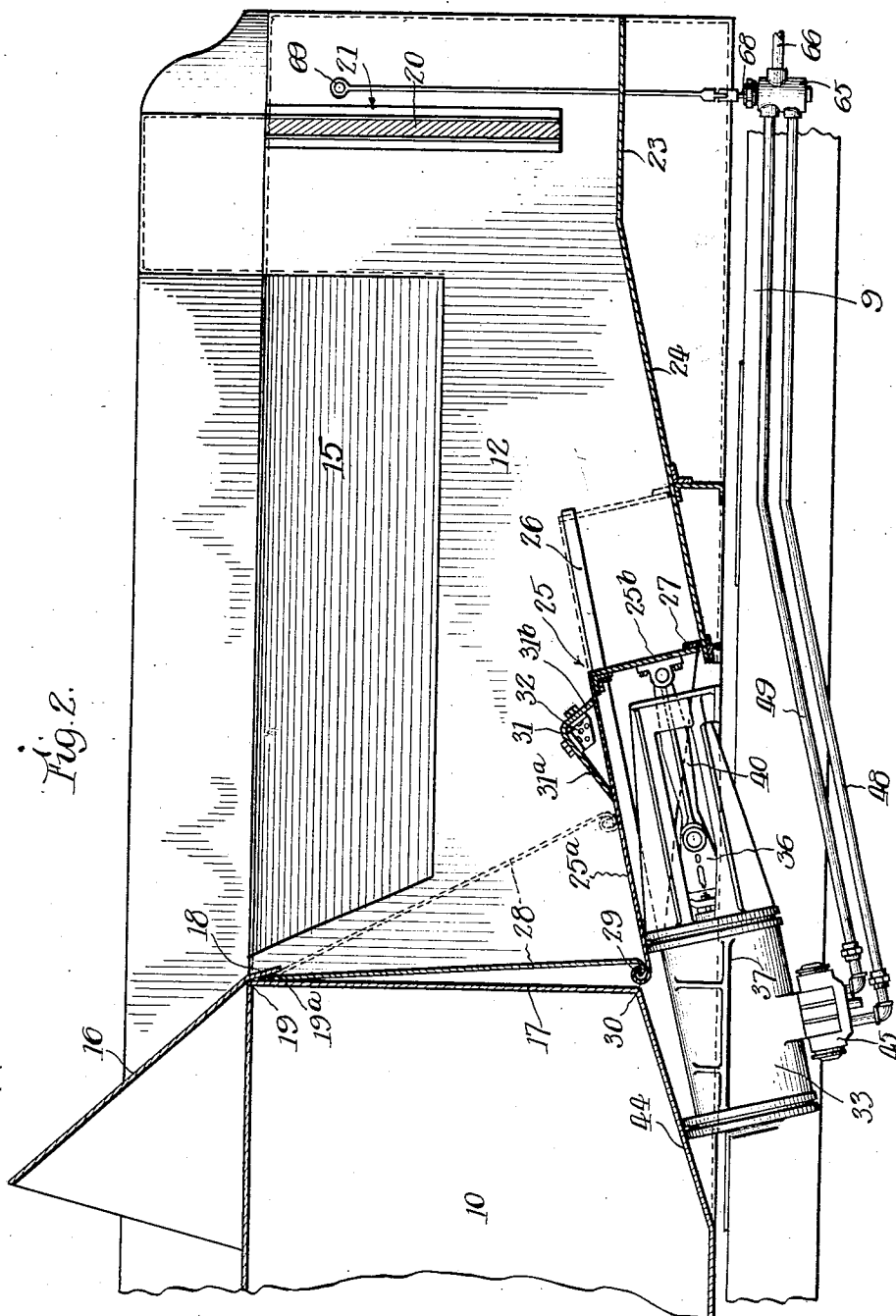

Fig. 2.

Inventor:
Ira C. Jordan,
By *Chas. H. Parker & Co.*
Attys

April 9, 1929.

I. C. JORDAN
COAL PUSHER

1,708,507

Filed May 5, 1926

3 Sheets—Sheet 3

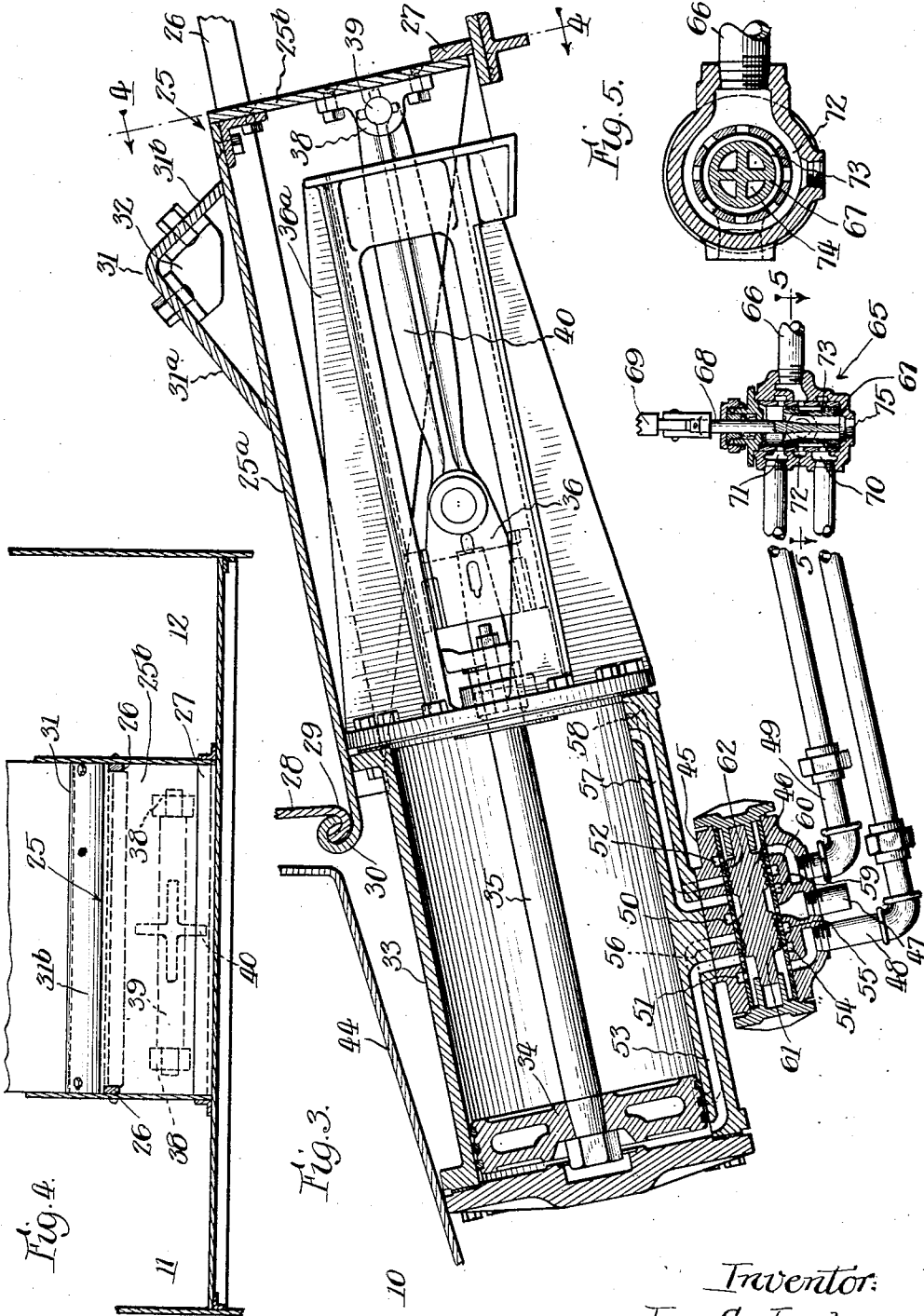

Inventor:
Ira C. Jordan,
By *Chindahl, Parker & Carlson*
Attys

UNITED STATES PATENT OFFICE.

IRA C. JORDAN, OF CHICAGO, ILLINOIS.

COAL PUSHER.

Application filed May 5, 1926. Serial No. 106,996.

This invention relates to coal pushers for locomotive tenders and the like.

In tenders especially it is very desirable that the coal be always available at the forward portion of the coal pit irrespective of the amount of coal remaining in the bin. It is furthermore desirable that the coal be taken from the bin in a well mixed condition, that is, a uniform amount of lumps and slack should be used throughout the entire emptying operation. Because of the vibrations of the tender the slack settles to the bottom and the lumps tend to remain on top. Ordinarily removal of the coal from the bottom of the pit first uses slack leaving the lumps for the last. When coal pushers are used to feed coal forwardly only from the bottom of the bin this situation is not remedied, the slack being removed first as is the case without coal pushers. It is therefore one object of the present invention to provide a mechanism which feeds coal forwardly from the entire rear portion of the pit.

Another object is to provide a coal pusher of a double acting character including in combination with a reciprocating plunger operating along the floor of the tender pit, a swinging plate or apron operating in the upper rear portion of the pit to feed the coal to the plunger.

Another object of the invention is to provide a coal pusher having the actuating mechanism therefor so located as to occupy a minimum amount of the space available for water and coal storage purposes, and so as to be readily accessible for cleaning and repair.

Still another object is to provide a pusher actuating mechanism readily controllable for motion in either direction from any position.

In the accompanying drawings there is shown a coal pusher embodying the principles of the present invention as it is preferably applied to the coal pit of a coal tender. It is to be understood, however, that the invention is not limited to such application nor is it limited to the precise form disclosed in the drawings and hereinafter more fully described. It is further understood that the invention is susceptible to such modifications and to alternative constructions as fall within the scope of the appended claims.

In the drawings Figure 1 shows a coal pit as provided by a locomotive tender.

Fig. 2 is a vertical cross section of the tender of Fig. 1 showing the coal pusher.

Fig. 3 is an enlarged view of the coal pusher showing in detail the controlling valve mechanisms.

Fig. 4 is a front view of the coal pusher taken in the plane of line 4—4 of Fig. 3.

Fig. 5 is a cross section of the hand controlled valve of Fig. 3 taken on the line 5—5 thereof.

Referring now to Figs. 1 and 2 of the drawings, I have shown a locomotive tender having a frame portion generally designated 9. On the frame rearwardly of the tender is a water tank 10 which extends along the sides of the tender at 11 and 12 thereby defining the side walls and rear wall of a rectangular coal pit 13. The tops of the side tank portions 11 and 12 slope inwardly and downwardly as shown at 14 and 15. An inclined plate 16 slopes upwardly and rearwardly from the top of the vertical wall 17 partitioning the tank 10 and coal pit 13. The end of plate 16 has an overhanging lip 18 covering the edge 19 of the water tank thereby forming an inverted pocket 19^a along said edge for a purpose which will presently appear.

The coal pit 13 has at its forward end the usual removable gate 20 held in guides 21. The floor of the pit is level at the gate 20 as indicated at 23, and within the pit is preferably rearwardly and downwardly inclined as indicated at 24.

At the lower rear portion of the coal pit is a plunger 25 arranged to reciprocate along the floor for the entire width of the pit. In the present instance the plunger is formed as a substantially right angular structure comprising a top plate 25^a, preferably arranged parallel with the floor, and a front plate 25^b, preferably perpendicular to the floor. Runners or guides 26 are provided on the side walls between the side tank portions 11 and 12, these guides or tracks being parallel to the floor 24, and therefore in the present instance inclined to the horizontal. A wearing plate or strip 27 is mounted on the bottom of the front plate 25^b to slide over the floor 24. By this construction, it will be observed, the usually employed cast metal trough or slideway is dispensed with. Such a trough is objectionable on account of the tendency of moisture to collect between it and the sheet metal structure, resulting in corrosion.

Swingably mounted in the rear portion of the pit above the reciprocating plunger 25, 26 is a plate or apron 28 constituting in effect a movable rear wall which is operatively associated with the reciprocating plunger so as to advance the coal forwardly over substantially the entire rear area of the pit. The upper end of the plate 28 is arranged in the present instance to enter the inverted pocket 19^a which thus forms a pivotal socket for the plate. The plate at the lower edge is so associated with the top plate 25^a of the plunger 25 that the two are movable together. In the present instance the parts are interlocked by a hinged joint formed by interengaging hooks 29 and 30.

It will be observed that the rear edge of the pit floor 24 terminates a substantial distance forwardly of the rear end of the pit, thus forming an opening in the lower rear portion of the pit through which the pusher operating mechanism may pass. This opening is closed by the pusher and the movable rear wall in all positions of the parts.

Above the plunger plate 25^a there is provided a stationary retaining means operating to prevent the coal advanced by the swinging plate 28 from being carried backward in the retraction of the pusher. In the present instance this means is in the form of an inverted V-shaped member 31 having a long upwardly sloping rear side 31^a and a short downwardly sloping forward side 31^b. Suitable brackets 32 on the side walls support the clearing means fixedly in the pit and in sliding contact with the top plate 25^a of the plunger 25.

Various mechanisms may be used for actuating the pusher but a fluid pressure actuated device is preferred. Thus I provide upon the frame 9 of the tender at the rear of the coal pit, and preferably somewhat under the main water tank 10, a cylinder 33 having the usual piston 34, rod 35 and cross head 36. The cylinder and associated parts are inclined in a direction parallel with the floor 24, and the cross head is guided in a similarly inclined guide structure 36^a extending forwardly from the cylinder. An integral ledge or rib 37 is formed on the cylinder block 33 for securing the same to the top of the tender frame members 9.

Preferably a pivotal link connection is used between the plunger 25 and the cross head 36. Thus, inside the space formed by the plates 25^a and 25^b of the plunger 25, the front plate 25^b is formed with spaced bearing lugs 38 for journaling the trunnions 39 of a link 40. The rear end of the link is pivoted to the sliding cross head 36.

In placing the cylinder in inclined position under the forward end of the water tank 10, it is only necessary to encroach slightly upon the water tank space. Thus,

the water tank has an inclined bottom wall 44. This arrangement of the parts is preferred to provide a maximum space for coal and water and to position the parts of the pusher so that inspection and repair are facilitated. When the parts are enclosed, as formerly, moisture collects and damage is incurred through rust and corrosion. It will be noted that the inclination of the floor is an important factor which permits the cylinder to be located considerably below the floor level of the tender and below the top level of the tender frame. In this position the parts become readily accessible from the under side.

On the lower side of the cylinder there is provided a slide valve mechanism for the actuating fluid. This comprises a tubular valve casing 45 with a double headed piston plunger 46 therein. A fluid exhaust connection 47 is positioned between two fluid admission connections 48 and 49. An annular exhaust chamber 50 in the valve casing surrounds the piston. Left and right annular admission chambers 51 and 52 also surround the piston within the valve casing, these three chambers being respectively associated with the connections 47, 48 and 49. The left end of the cylinder is connected by a passageway 53 to the left one of two other annular chambers 54 and 55 located between the similar chambers 50 and 51. Chamber 55 is connected by a passageway 56 leading into the cylinder. The end of passageway 56 is so positioned that it is covered and uncovered by the piston head 34 moving to and from the extreme rear end of its stroke. Similarly, the right hand end of the cylinder 33 is connected by similar passageways 57 and 58 which are respectively connected to annular chambers 59 and 60, thereby to make similar both ends of the cylinder and the valve. The piston 46 has one head 61 arranged when in its extreme right hand position to permit fluid admission via connection 48, chamber 51, chamber 54, passage 53, and to permit exhaust via chamber 57, chamber 59, chamber 50 and connection 47. The other head 62 duplicates head 61 and at this position closes the admission through the valve between admission pressure chambers 52 and 60. Each head on the plunger acts to move the valve piston on the application of pressure from either end.

The manual controlling valve structure for pressure fluid as herein employed is designated generally as 65. The fluid lines 48 and 49 above described are connected into the valve structure 65 to which leads also a fluid supply pipe 66 connected to either steam, water or air as desired. Within the valve there is a reciprocal plunger 67 serving as a valve member. The plunger is operatively controlled by means of an outside

extension thereof 68 well packed in the valve casing. A control handle 69 is connected to the plunger extension 68 and is preferably located on the tender at the forward portion of the coal pit or in front of the gate. Within the valve casing there are ported annular chambers 70, 71 and 72 which communicate with the pipe connections 48, 49 and 66 respectively. The plunger 67 is recessed by forming an annular channel 73 therein leaving the ends of the plunger to act as piston heads. The plunger is so designed that the heads serve to cut off communication from the inlet to either outlet or both outlets. In Fig. 3 the plunger is shown at its lowermost position admitting fluid to the lower pipe 48 and cutting off fluid from the upper pipe 49. Plunger 67 is desirably provided with holes 74 through the center which permit release of pressure in the cut-off line by communicating with the atmosphere through a hole 75 in the end of the valve casing. By positioning the plunger at the upper portion of the valve casing (Fig. 3) the fluid is admitted to pipe 49 and the pressure in pipe 48 is released through the valve casing port 75. By positioning the valve plunger 67 midway of its two end positions the piston heads serve to cut off the ported chambers 70 and 71 from communication with the live pressure chamber 72.

Assuming that the coal pit is filled, with the pusher in the rear or full line position, the operation is as follows: The hand valve 69 is operated in a direction to admit fluid pressure such as steam to the pipe 48, so as to move the piston 34 forwardly. Accordingly, coal is advanced by the swinging plate 28 from the upper rear portion of the pit, and coal in front of the plunger 25 is fed forwardly for use. Thereupon this hand valve is operated to admit fluid pressure to the pipe connection 49 whereby to move the piston 43 rearwardly and retract the pusher. Retraction of the plunger 25 carries with it the rear plate 28. The retainer member 31 in this operation prevents the coal advanced by the plate 28 from moving rearwardly, and thus causes a considerable amount of coal to drop to the floor of the pit in front of the retracted plunger 25. The operator now again moves the handle 69 in the other direction to advance the pusher as above set forth. By this means the coal in the tender is fed toward the gate and is taken in part from the top of the supply, fed downwardly, and then forwardly toward the gate. This results in feeding forwardly a uniform mixture of lump and slack coal.

I claim as my invention:

1. In a locomotive tender a coal pit having a floor upwardly inclined from the rear, a tender frame upon which said coal pit floor is supported, a coal pusher slidable along the inclined floor, a fluid pressure cyl-

inder axially parallel with the floor and located in part below the top level of the tender frame, a piston operable in said cylinder to move the coal pusher, and fluid pressure control means for said cylinder.

2. In a locomotive tender a coal pit having a floor upwardly inclined from the rear, a tender frame upon which said coal pit floor is supported, a coal pusher slidable along the inclined floor, a fluid pressure cylinder axially parallel with the floor and located in part below the top level of the tender frame, a piston operable in said cylinder to move the coal pusher, and fluid pressure control means for said cylinder, said means including fluid admission connections for each end of the cylinder and an automatic slide valve mechanism adapted to respond to the pressure of fluid admitted through said connections to control the admission to and exhaust from said cylinder.

3. In combination a coal pusher for the bottom of a coal pit, and means on the side walls of the pit operating to slidably support the coal pusher for movement in parallel relation to the floor whereby to prevent a wearing action of the pusher on the floor of the pit.

4. A coal pusher for a coal pit having parallel side walls comprising, in combination, a reciprocatory structure having a top plate substantially parallel with the floor of the pit, and a front plate substantially perpendicular to the floor of the pit, and means upon the side walls and parallel to the floor operatively engaging with the sides of the pusher so as to slidably support the pusher.

5. A coal pusher for a coal pit comprising, in combination, a reciprocatory member operative at the rear of the coal pit along the floor, a plate set against the rear wall of the coal pit, the lower edge of said plate being associated with the reciprocatory member so as to be carried thereby to swing the plate whereby the coal is moved forwardly by the plate and also carried by the reciprocatory member.

6. In combination, a coal carrier and pusher arranged to advance along the floor of a coal pit, and a retaining means fixed in the pit over the pusher, said means at the rear side presenting a long sloping face to the coal carried on the upper side of the pusher and on the forward side presenting an abrupt clearing face to remove coal from the top of the pusher on retraction of the pusher.

7. In combination, a coal carrier and pusher arranged to move along the floor of the coal pit and a retaining means fixed in the pit over the pusher, said means permitting coal being carried by the pusher to pass by the retaining means and being adapted to scrape the coal from the top of the pusher on retraction of the pusher.

8. In combination, a reciprocatory coal pusher, fluid pressure operated means for reciprocating said pusher, said means comprising a piston and cylinder, a slide valve associated with said cylinder to control the admission to and exhaust from both ends of the cylinder, and a hand control two-way fluid valve connected to said slide valve for admitting fluid to either end of the cylinder.

9. In combination, a coal pit having a portion of the rear wall arranged to swing inwardly and upwardly and having a floor upwardly inclined from the rear, and a hand controlled coal pusher reciprocable along the floor and adapted to swing the wall.

10. In combination, a coal pit having an upright rear wall portion arranged to swing forwardly and a hand controlled reciprocable coal pusher operatively associated with the lower portion of said rear wall to move it.

11. In combination, a coal pit having a portion of the rear wall arranged to move forwardly, and a manually controllable reciprocatory coal pusher movable over the floor of the pit arranged to move the wall.

12. In combination with a locomotive tender having a water tank and a coal pit having an inclined floor, of a reciprocable coal pusher arranged to move coal upwardly over the inclined floor, and actuating means for the pusher located beneath said tank.

13. In a locomotive tender, a coal pit having a rear wall and a bottom wall terminating at a point spaced forwardly from the rear wall, a coal pusher slidable along the bottom wall, a fluid pressure cylinder beneath the rear wall, and a piston operable in said cylinder and operatively connected with said pusher, said rear wall being movable with the coal pusher, and the coal pusher and said rear wall serving to close the lower rear portion of the pit.

14. In a locomotive tender, a coal pit formed with an opening at its lower rear end, a coal pusher movable along the floor of the pit, means movable through said opening and operating to move the pusher along the bottom of the pit, and a swinging wall coacting with the pusher to close said opening.

15. In a locomotive tender, a coal pit formed with an opening at its lower rear end, a reciprocable member movable through said opening, and means compris-

ing a reciprocable member and a swinging wall coacting to close said opening in the operation of said member to effect the movement of coal forwardly in the pit.

16. In a locomotive tender, a coal pit having an opening formed in its lower rear portion, a coal pusher movable over the bottom of the pit and being located in its rearmost position so as to close said opening, said pit having a rear wall the lower edge of which is operatively connected with the coal pusher so as to move with it, and means for securing the upper edge of said movable wall adapted to permit the latter to move with the coal pusher.

17. In a locomotive tender having a water tank including opposite elongated side portions and a coal pit formed between said side portions, a coal pusher mounted for movement within the pit in parallel relation to the bottom wall thereof, means mounted directly on the inner side walls of the tank with which said pusher directly engages and slidably carrying the entire weight of the pusher, and power means for operating said pusher.

18. In a locomotive tender having a water tank with a main portion located rearwardly of the tender and side portions extending forwardly and forming a coal pit therebetween, said pit having a bottom wall inclined upwardly and forwardly, a coal pusher movable over said wall, a fluid pressure cylinder beneath the main portion of the tank having its axis substantially parallel with the inclined floor of the pit, a piston in said cylinder operatively connected with the coal pusher, and means for controlling the flow of pressure fluid to the cylinder to operate the pusher.

19. In a locomotive tender, a coal pit having a coal pusher reciprocable over the bottom of the pit, means for reciprocating the coal pusher, means positioned above the coal pusher and operable in one forward stroke of the pusher to advance a quantity of coal to a point beyond the front end of the pusher when in its rearmost position and means operating to hold the coal in its advanced position, whereby in the return movement of the pusher, coal thus advanced becomes deposited in front of the pusher.

In testimony whereof, I have hereunto affixed my signature.

IRA C. JORDAN.