



US 20070062898A1

(19) **United States**

(12) **Patent Application Publication**  
**Choi**

(10) **Pub. No.: US 2007/0062898 A1**

(43) **Pub. Date: Mar. 22, 2007**

(54) **PREFABRICATING RACK FRAME**

(30) **Foreign Application Priority Data**

(75) Inventor: **Cheon Soon Choi**, Chungcheongbuk-do  
(KR)

Apr. 14, 2003 (KR) ..... 10-2003-0023502

Apr. 13, 2004 (KR) ..... 10-2004-0025202

**Publication Classification**

Correspondence Address:  
**SHERIDAN ROSS PC**  
**1560 BROADWAY**  
**SUITE 1200**  
**DENVER, CO 80202**

(51) **Int. Cl.**  
**A47B 43/00** (2006.01)

(52) **U.S. Cl.** ..... **211/192; 211/187**

(57) **ABSTRACT**

(73) Assignee: **TEKNOA INDUSTRIAL INC.**, Seoul  
(KR)

The prefabricating rack frame are comprised of a column and a cross member. The column have plural slots along a longitudinal direction at an even interval, and the cross member have a pair of hooks to be inserted into respective slot, and a location restrictor is formed between the upper and the lower hook and bent rectangular to the hook, and tightly contracted on the outer surface of the column. The cross member further has a pit and a reinforcement rib; the pit is formed at the outer corner where each longitudinal end of the cross member meets the foot of the location restrictor; and a reinforcement rib is provided at the inner corner of the location restrictor and its configuration counterposes to that of the pit.

(21) Appl. No.: **10/553,313**

(22) PCT Filed: **Apr. 14, 2004**

(86) PCT No.: **PCT/KR04/00867**

§ 371(c)(1),  
(2), (4) Date: **Jun. 15, 2006**

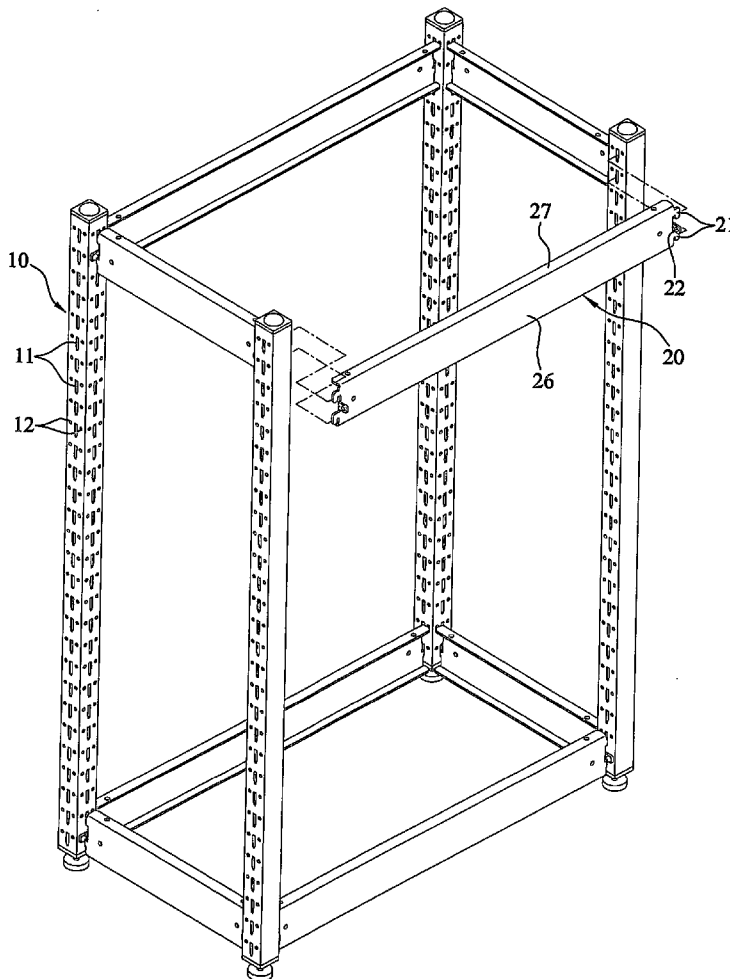
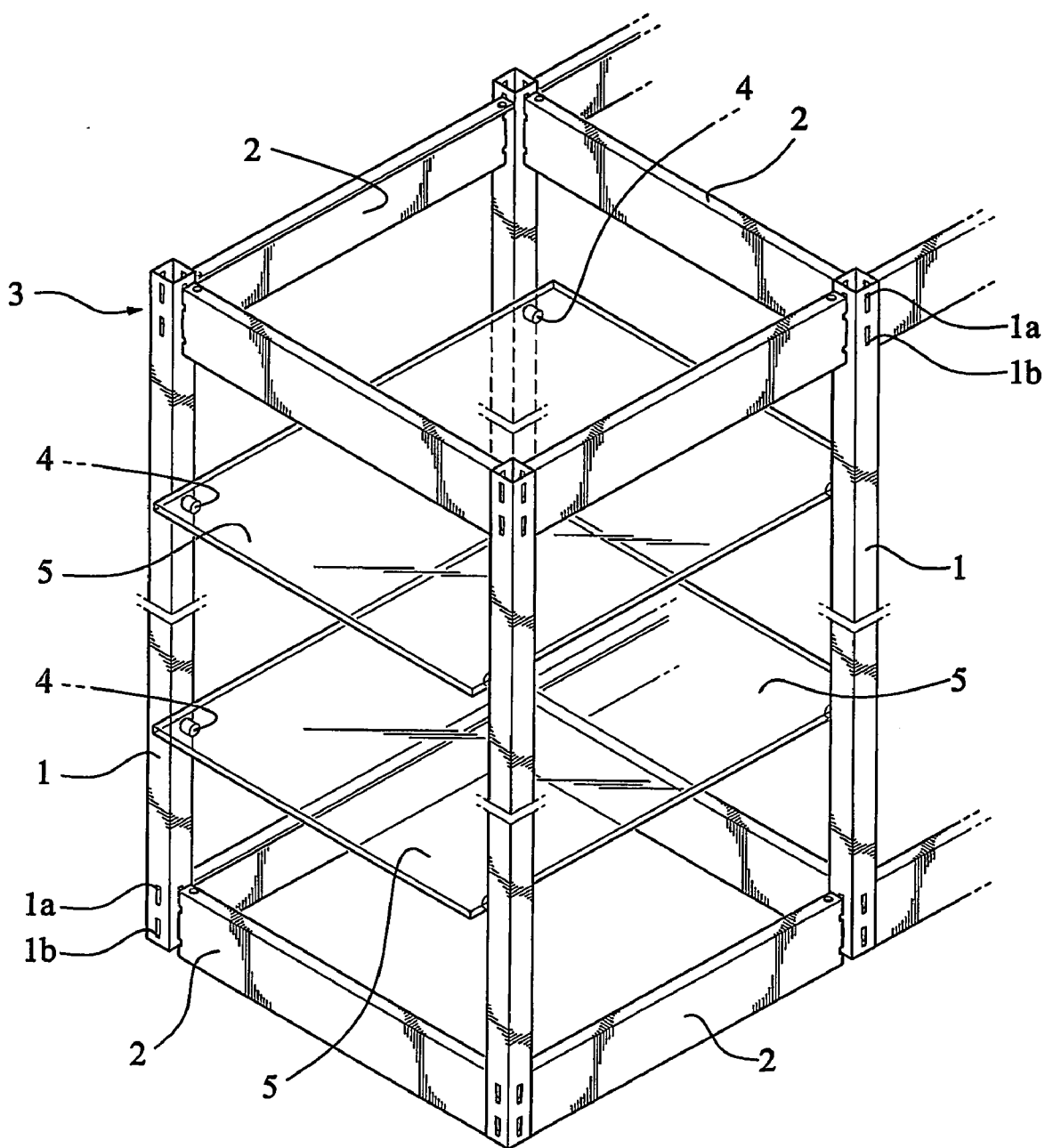
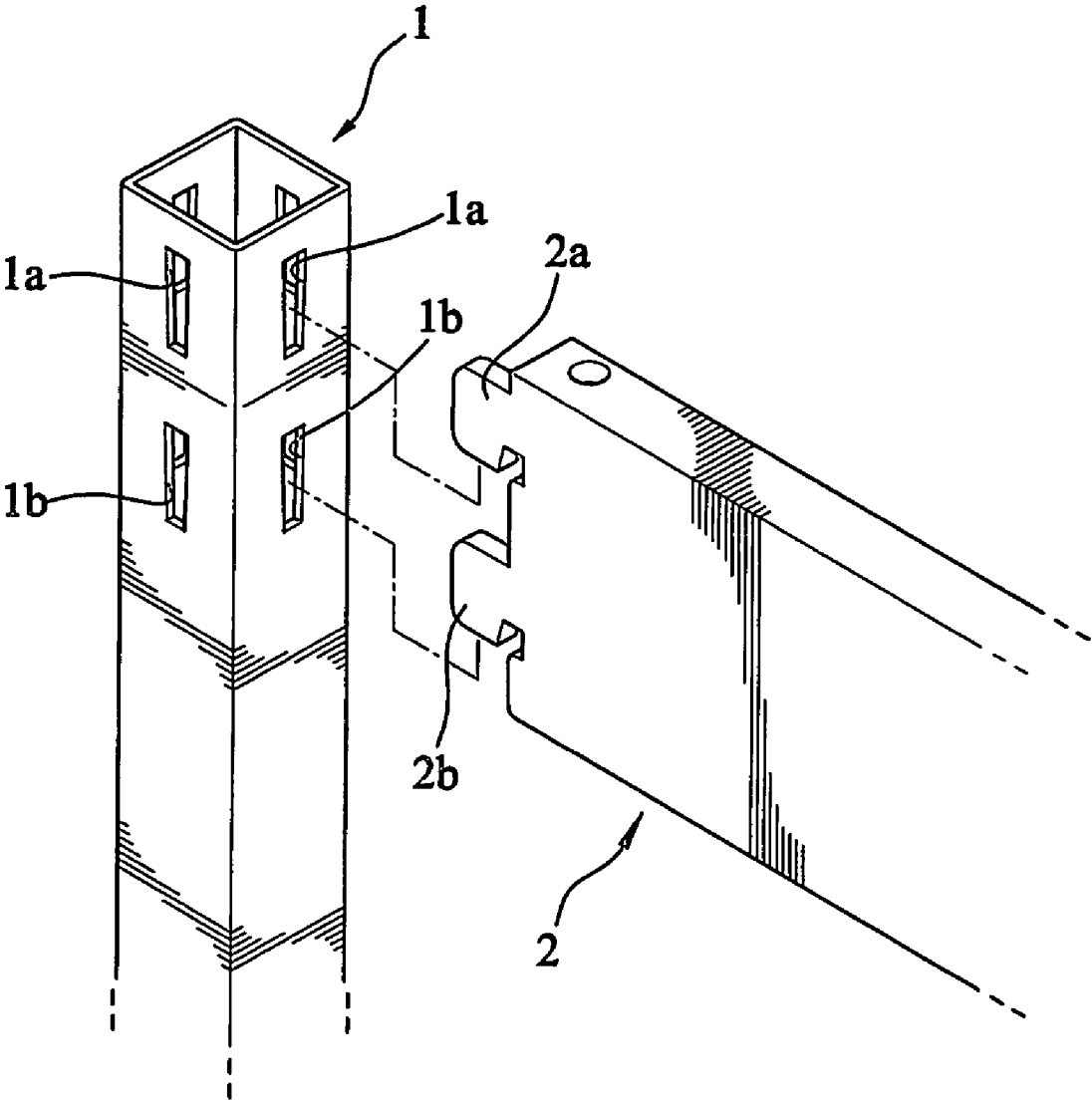

FIG. 1  
- PRIOR ART -



**FIG. 2**  
**- PRIOR ART -**



**FIG. 3**  
**- PRIOR ART -**

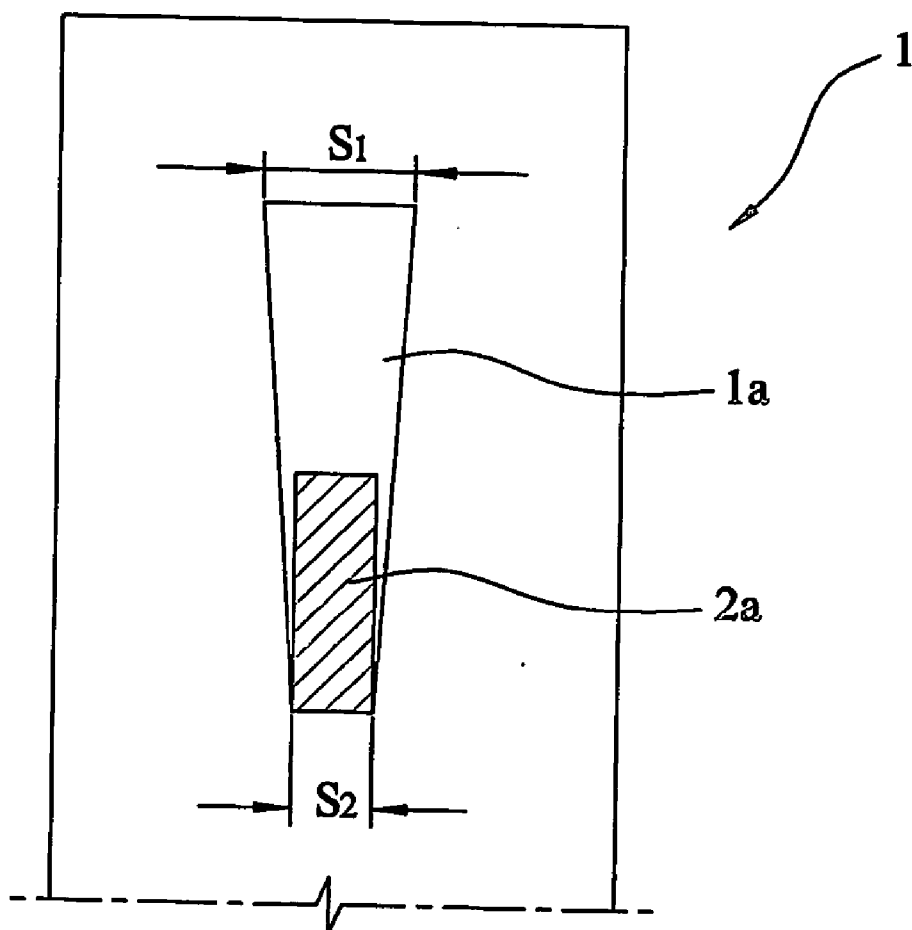

FIG. 4

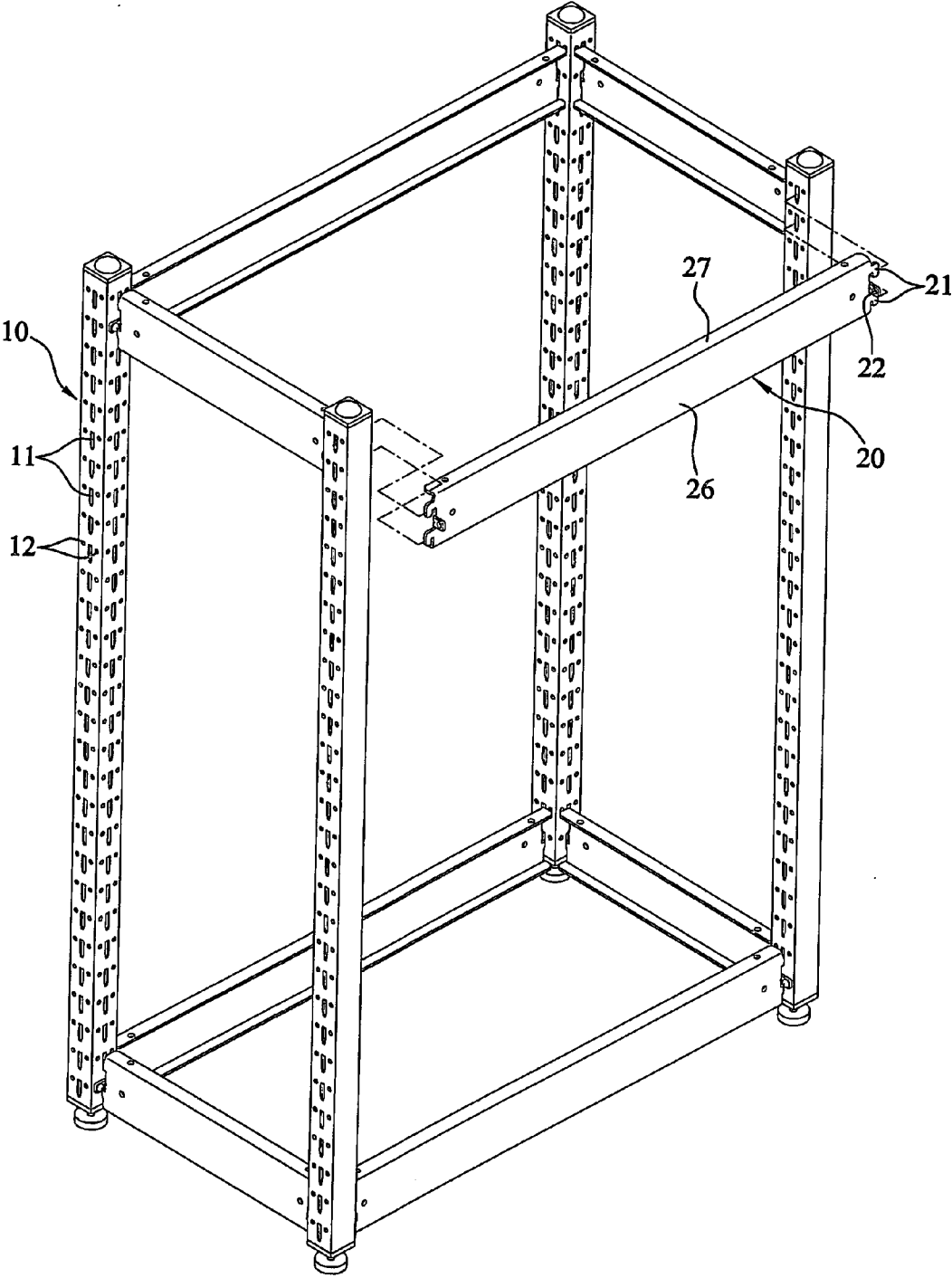

FIG. 5

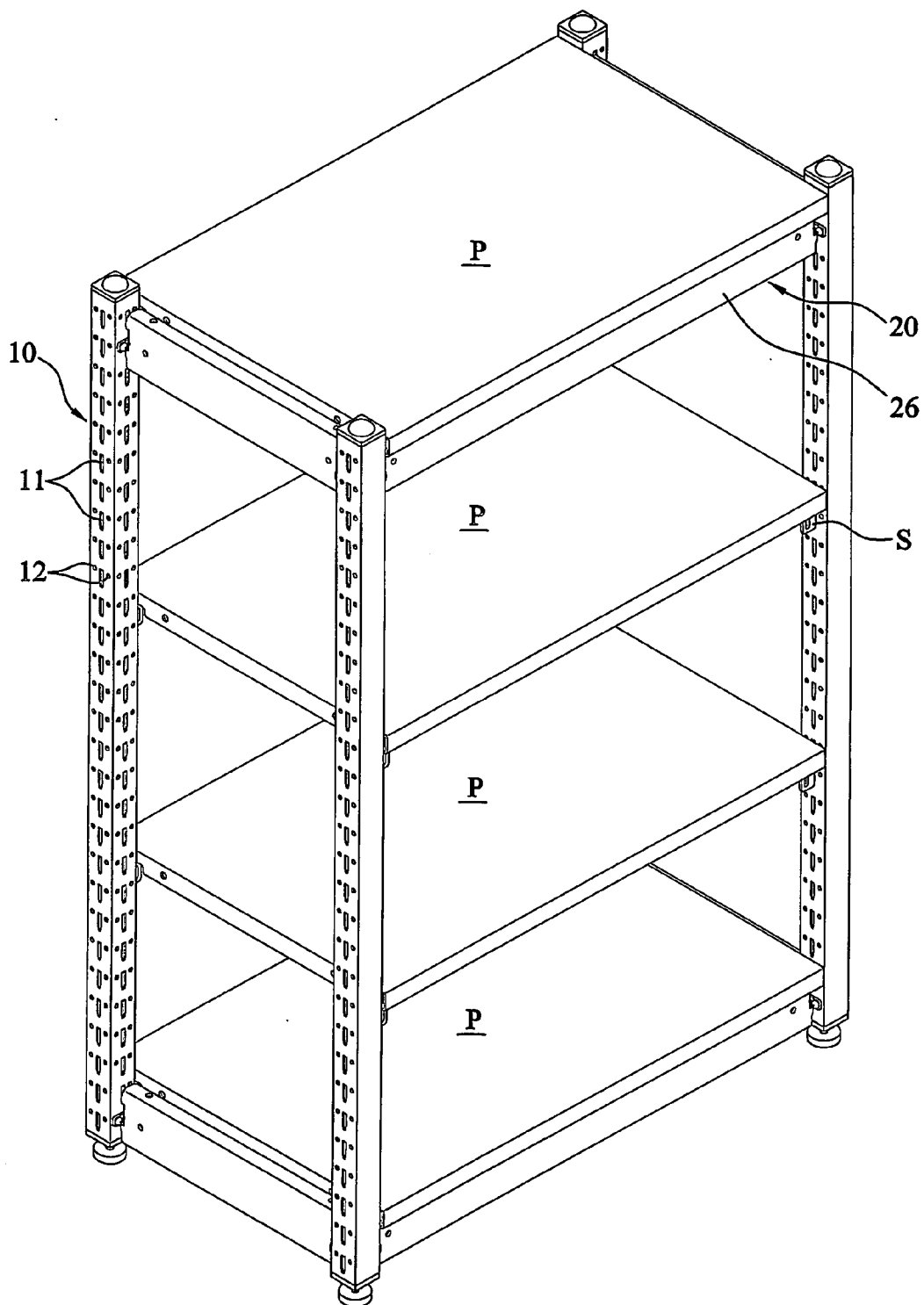

FIG. 6

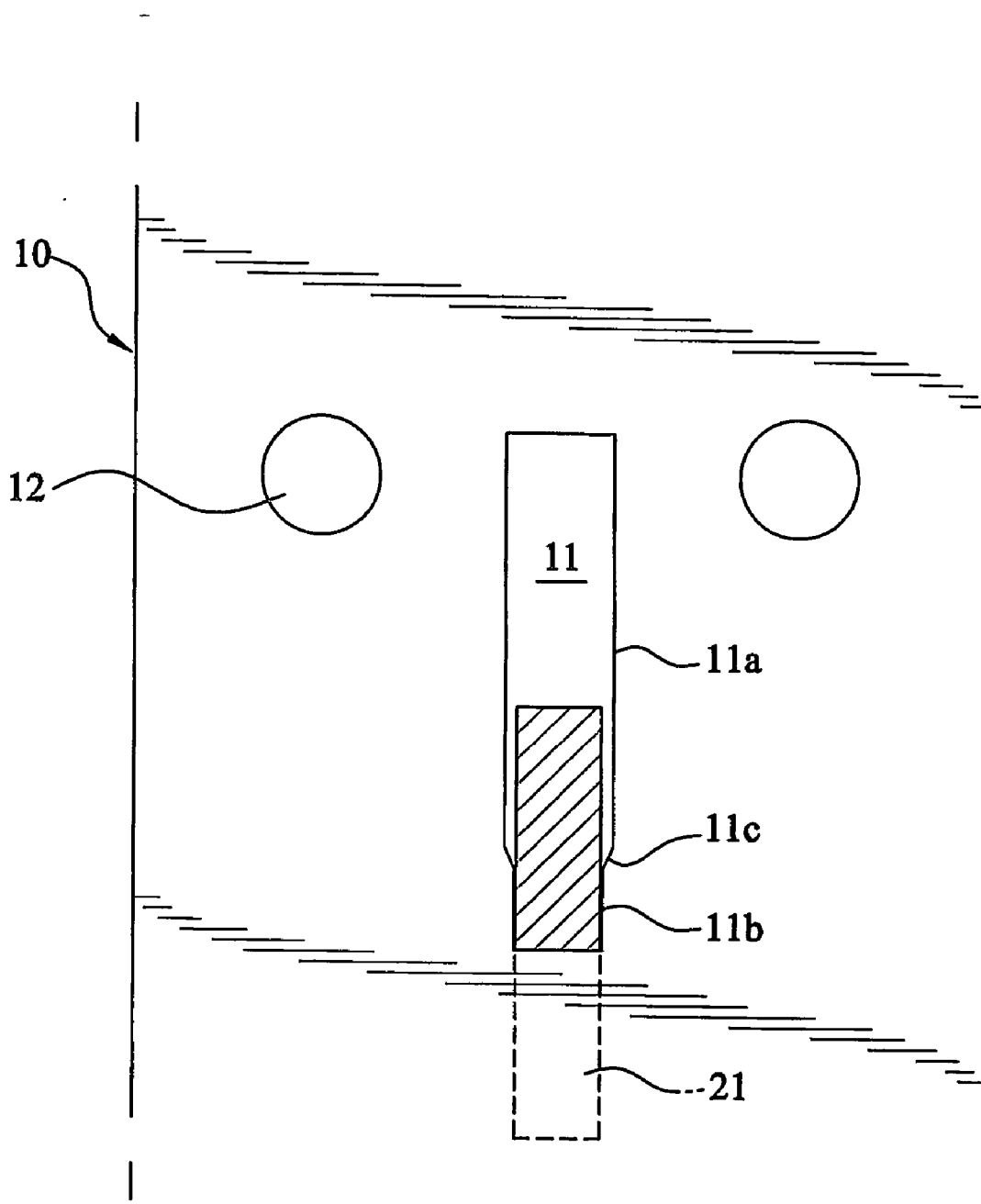

FIG. 7

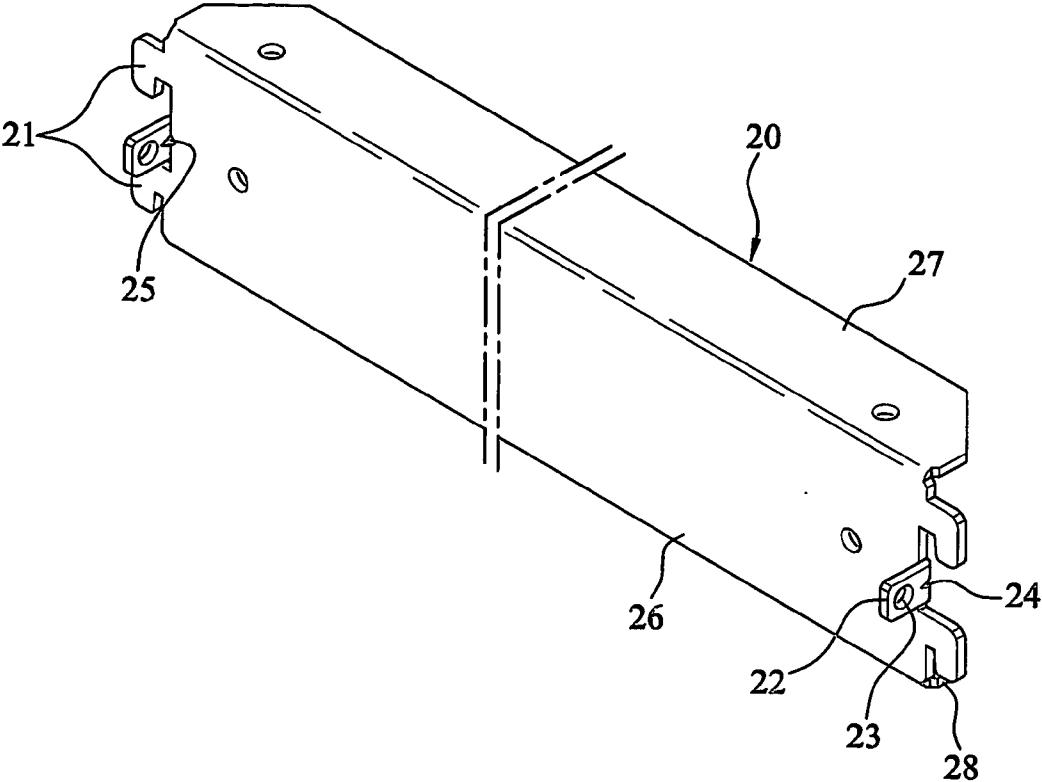

FIG. 8

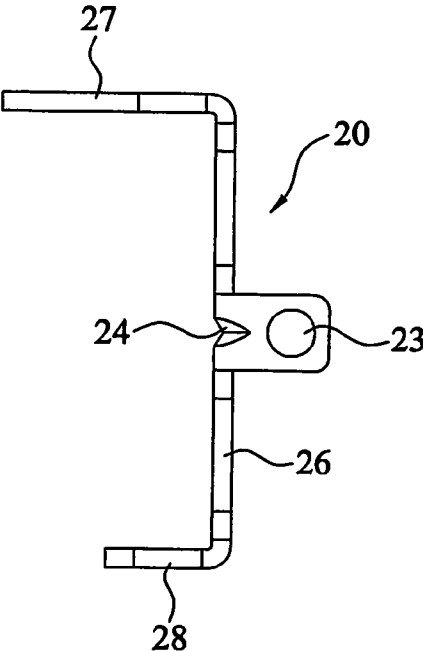



FIG. 9

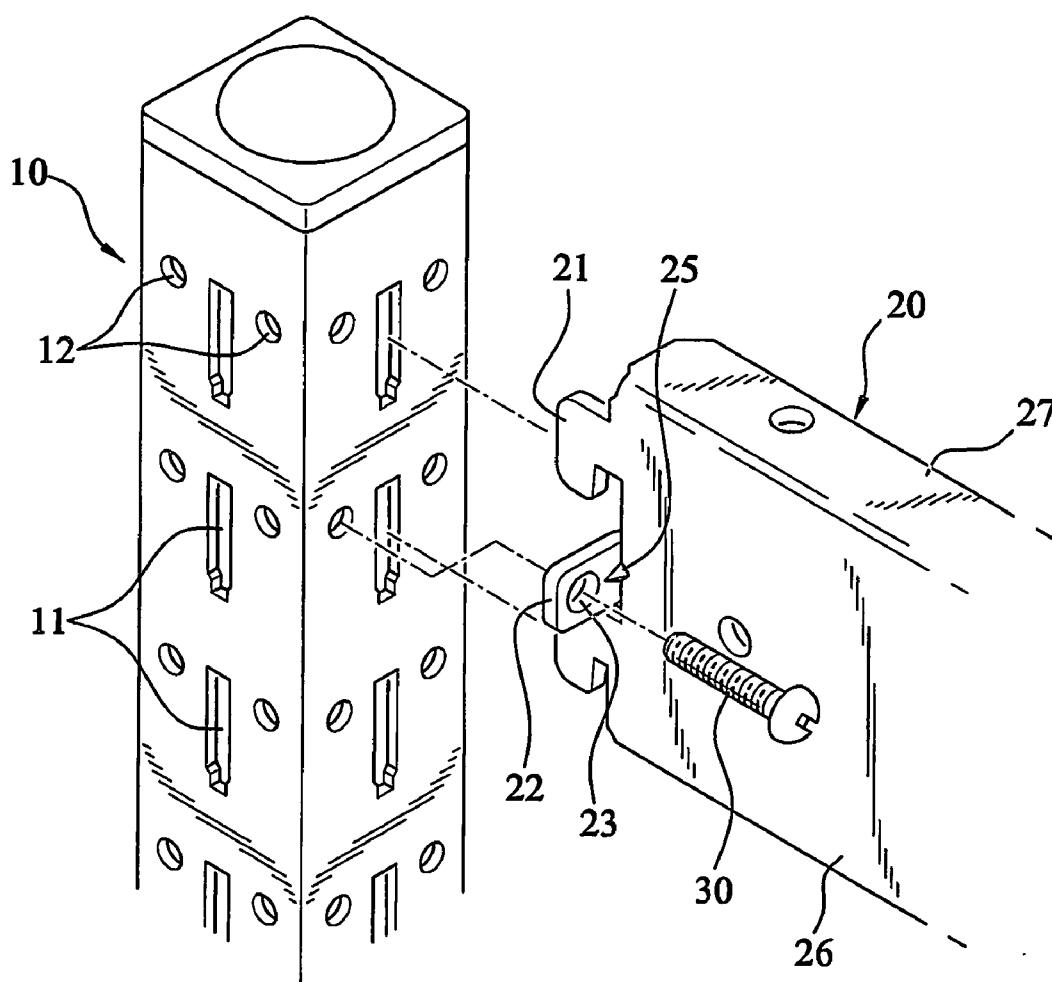

FIG. 10

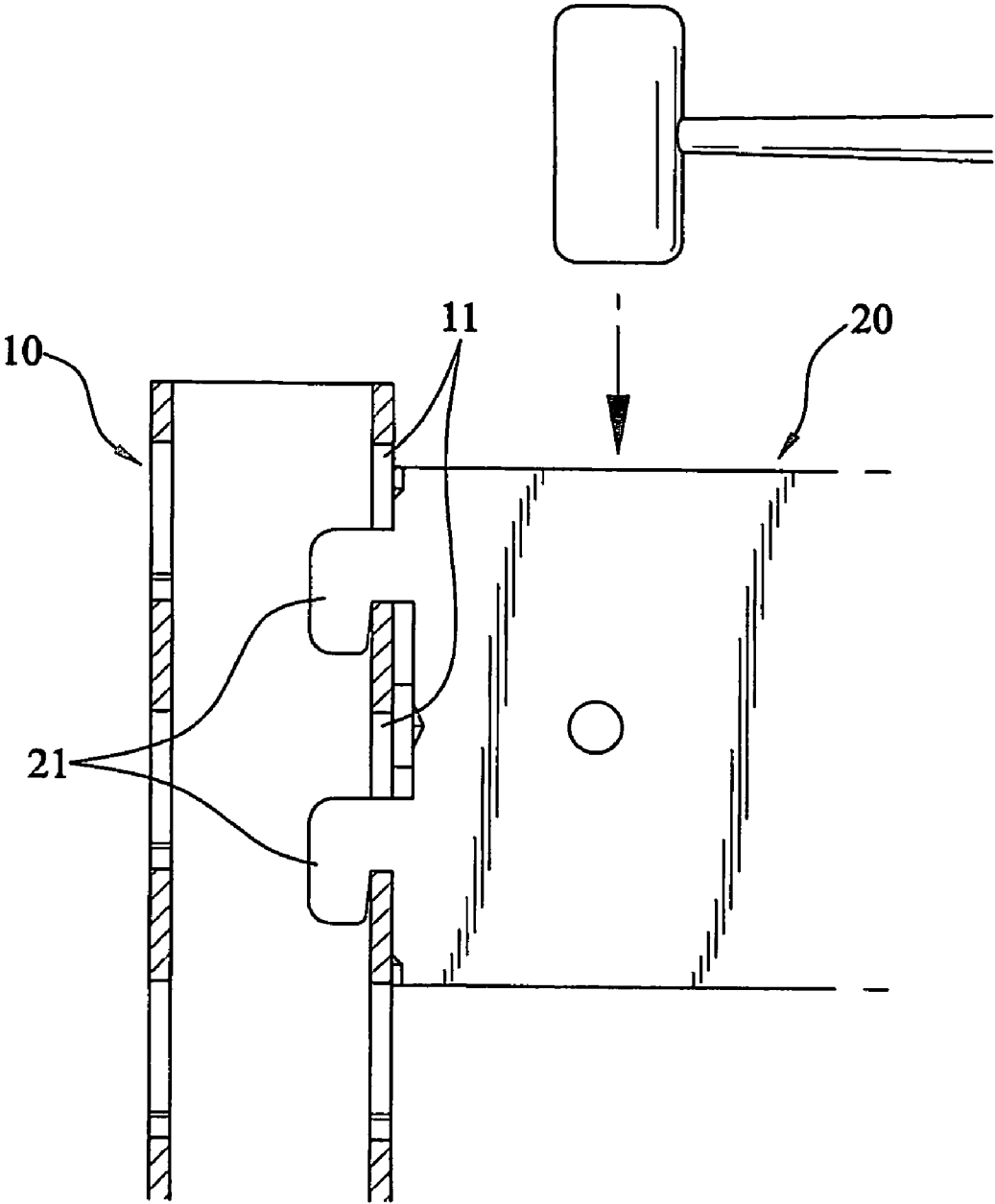



FIG. 12

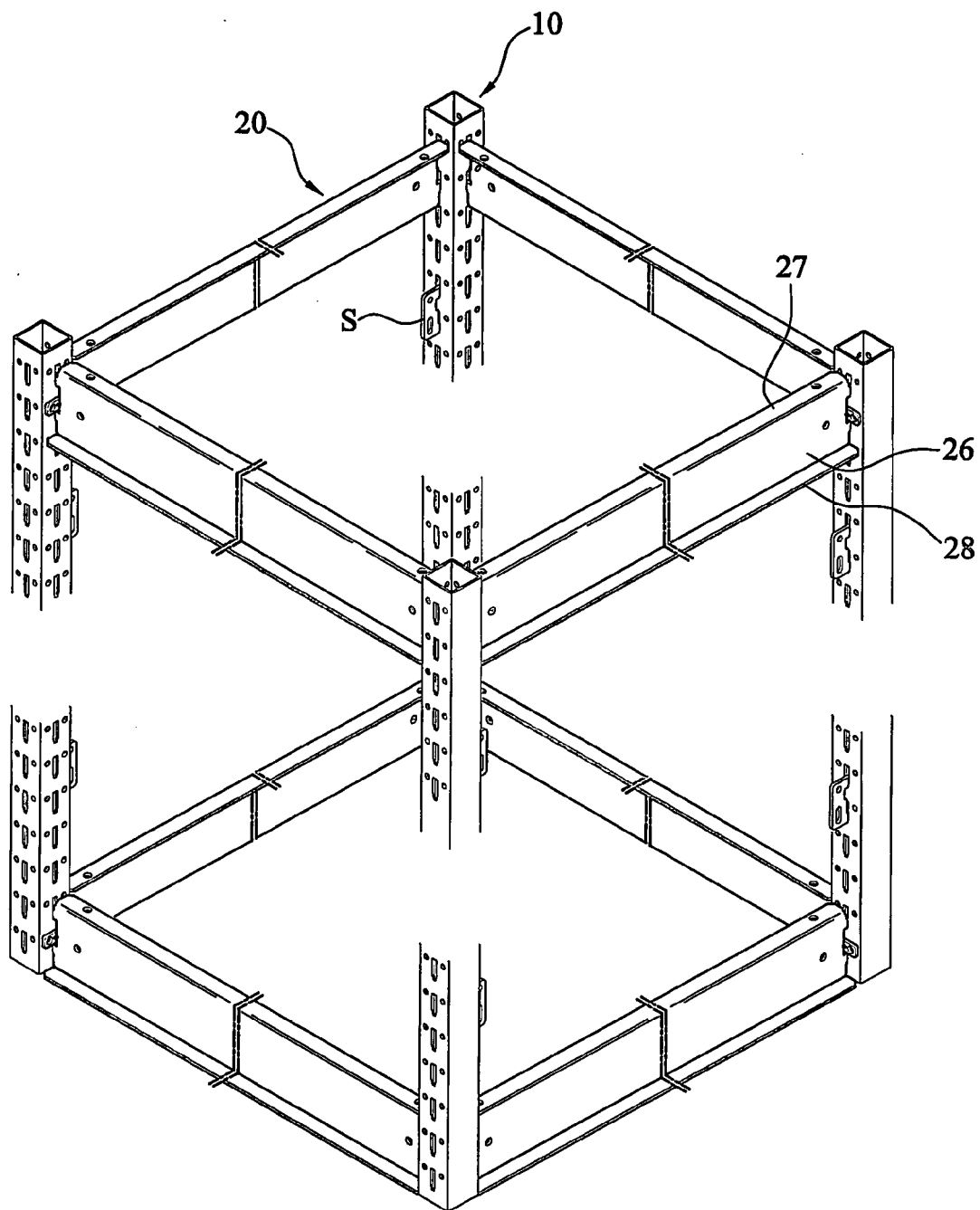

FIG. 13

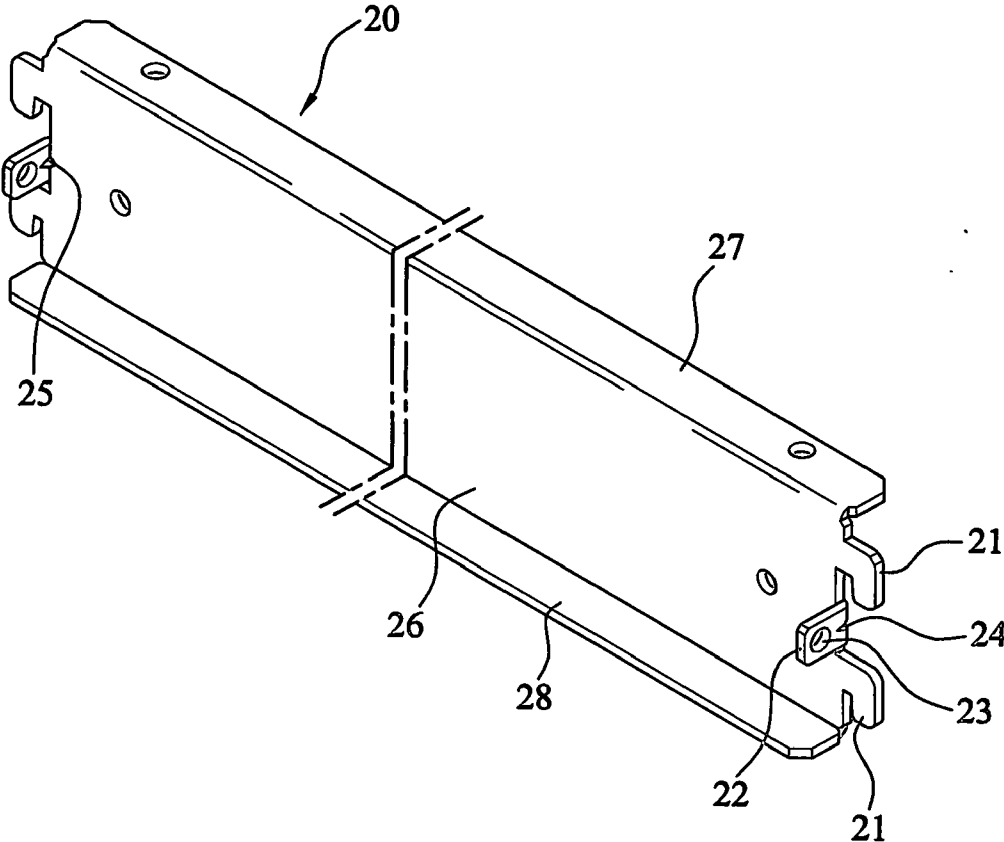

FIG. 14

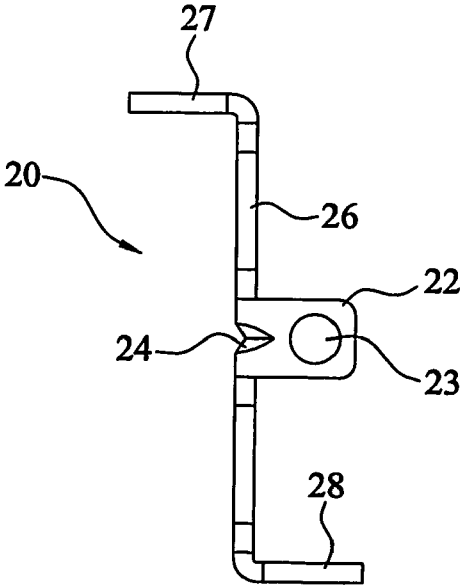

FIG. 15

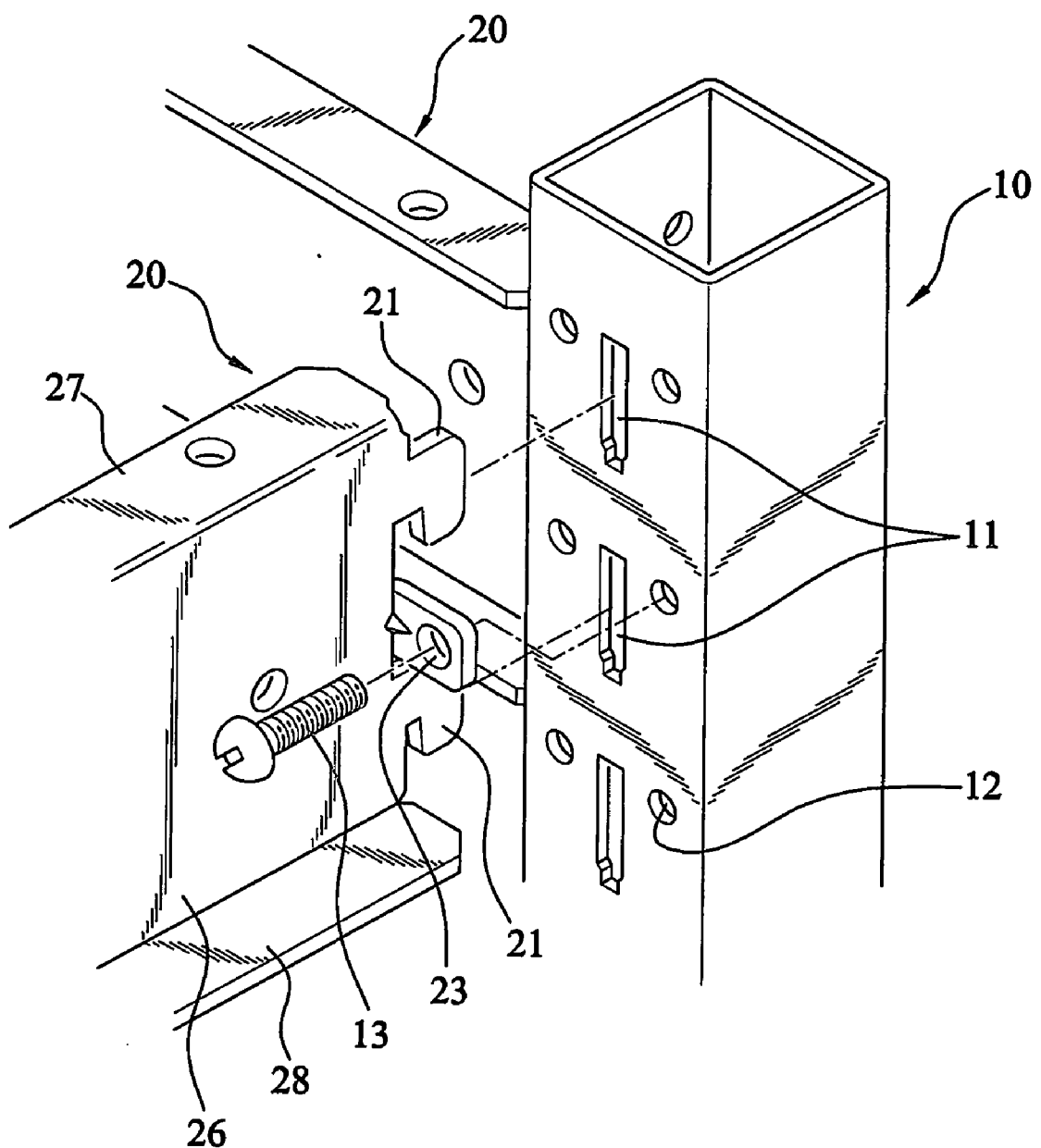

FIG. 16

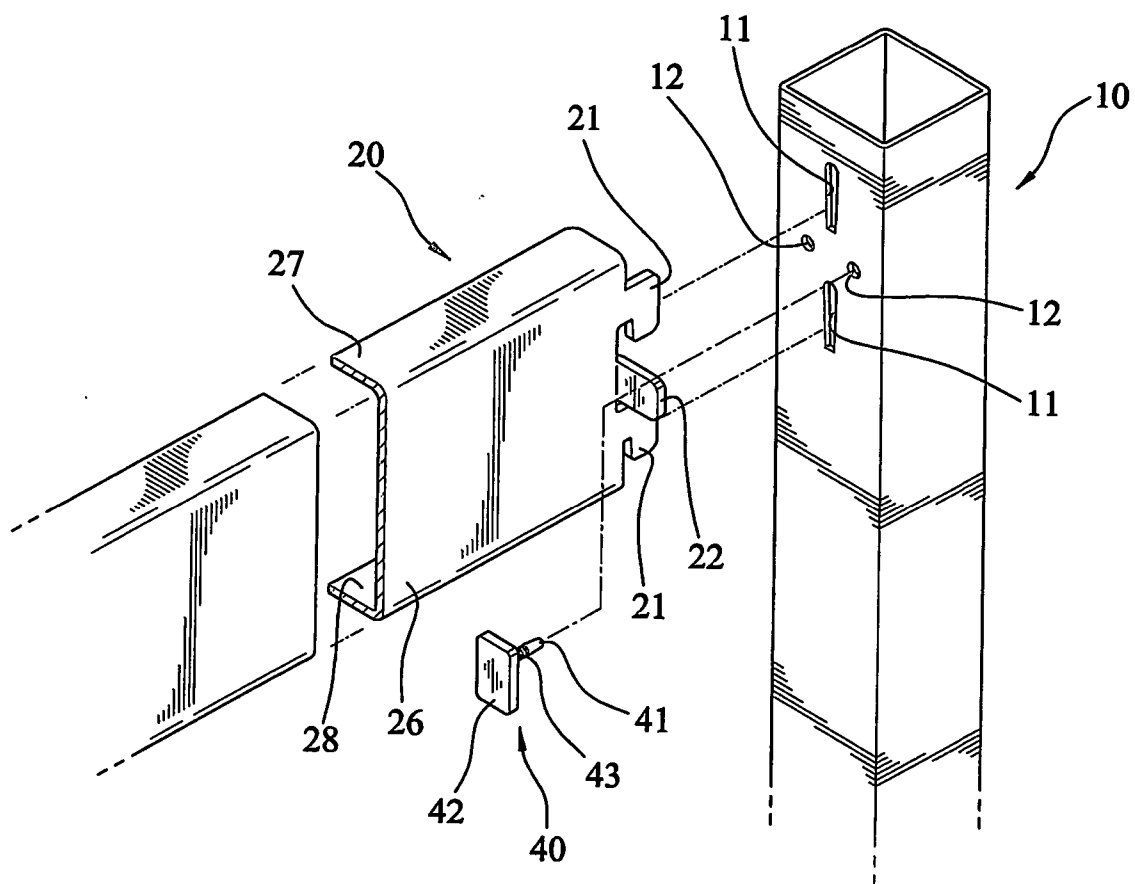

FIG. 17

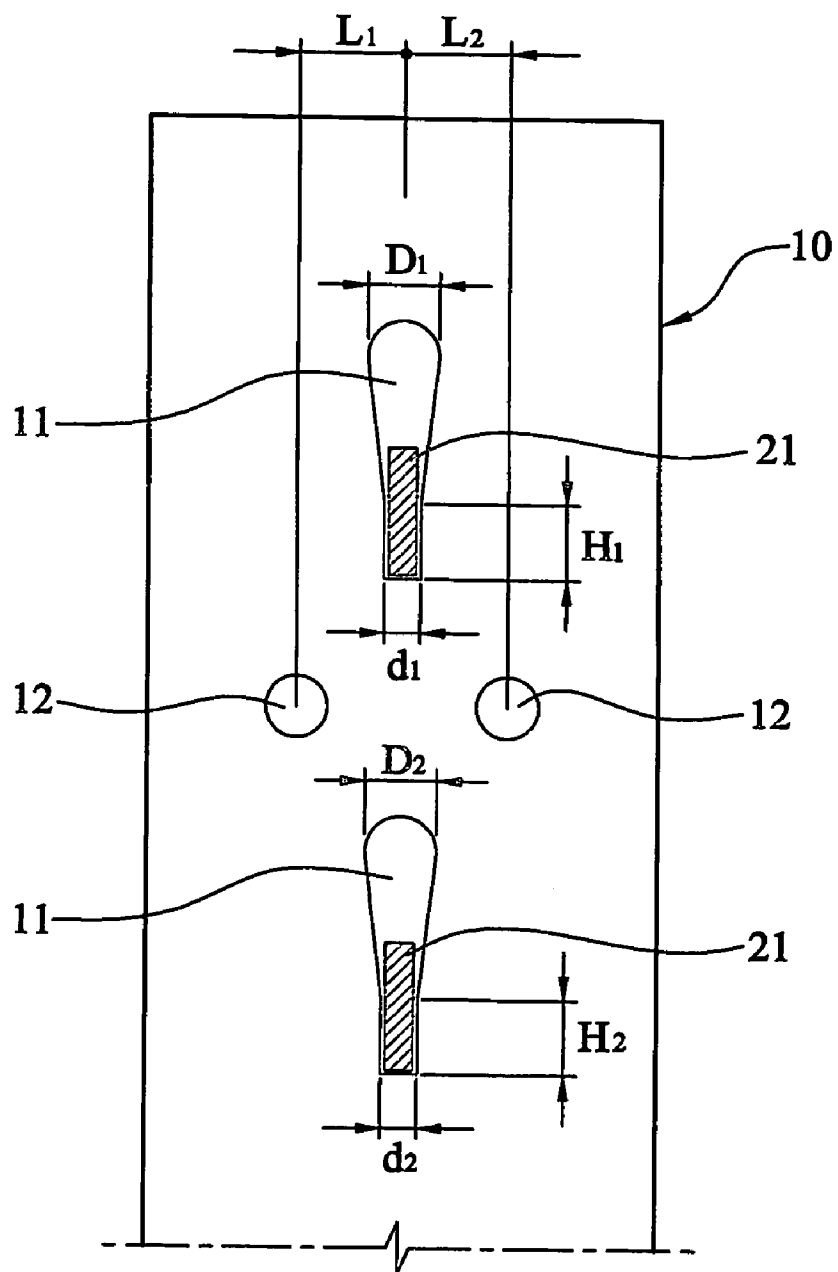



FIG. 18

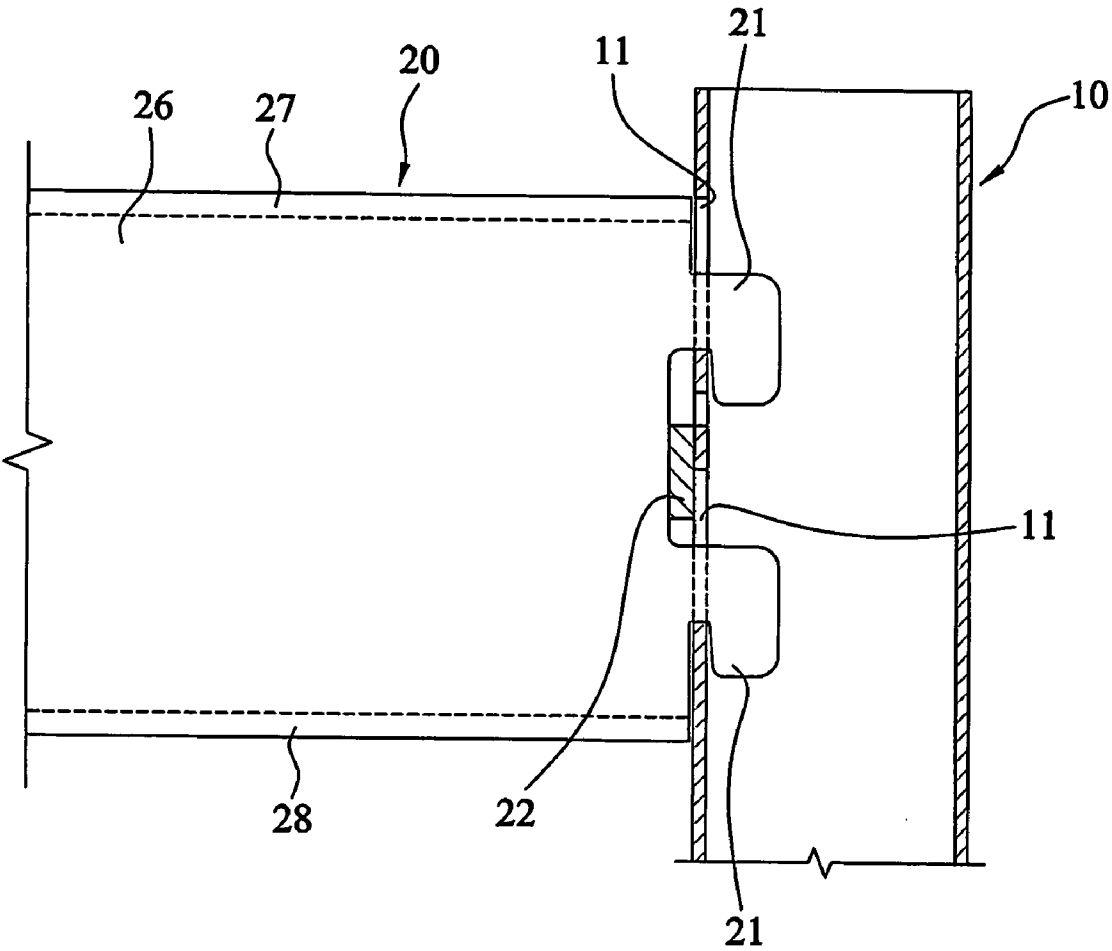

FIG. 19

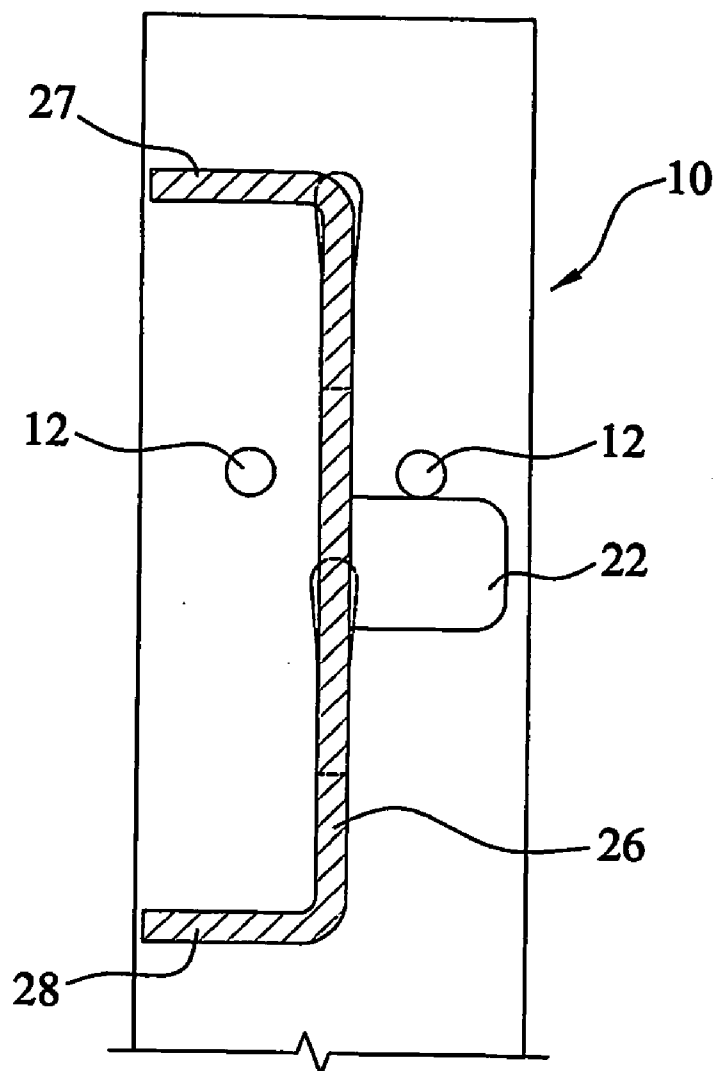

FIG. 20

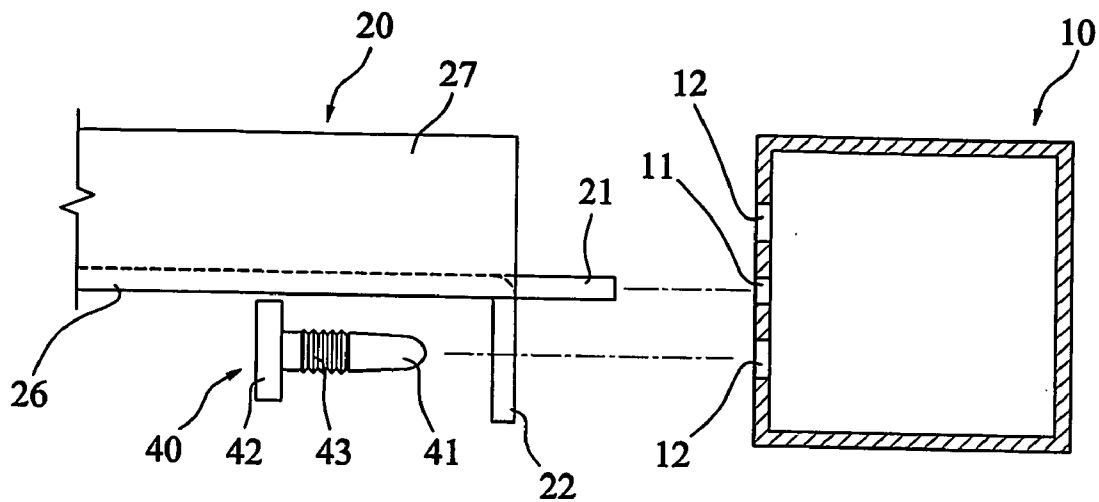

FIG. 21

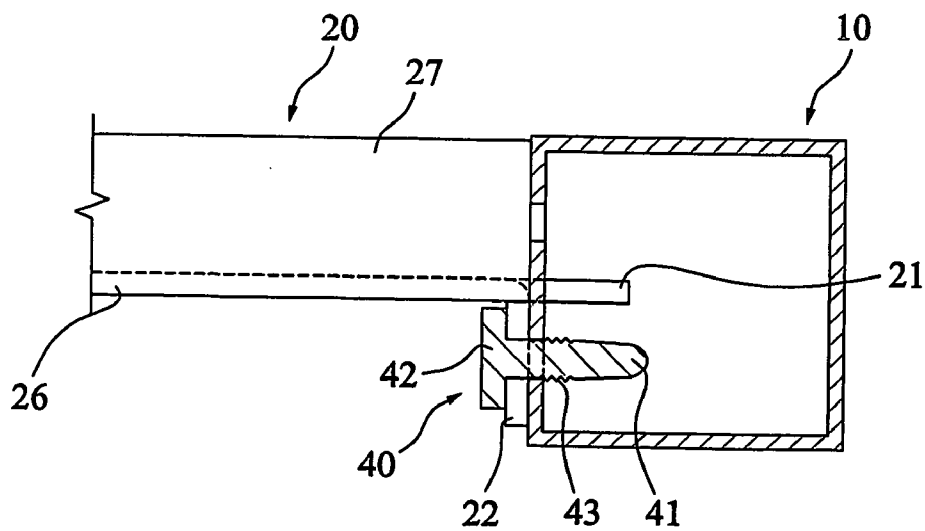

FIG. 22

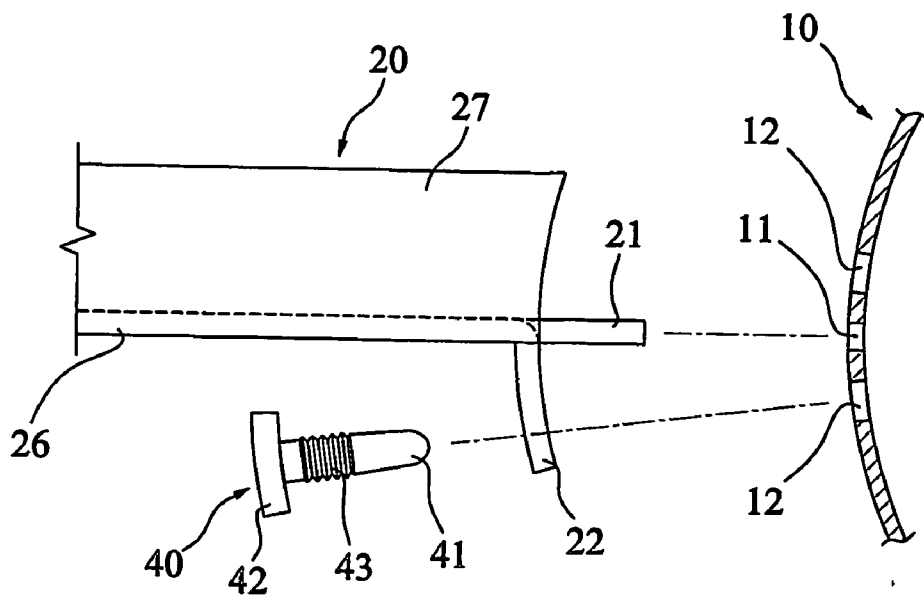
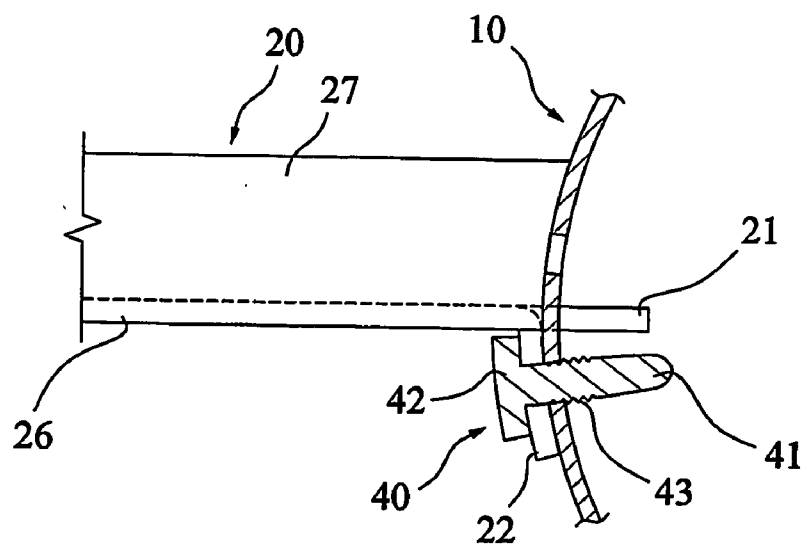

FIG. 23



## PREFABRICATING RACK FRAME

### TECHNICAL FIELD

[0001] This invention relates to a prefabricating rack frame that can be installed at a store, warehouse, or a library, and on which different types of goods can be placed. The invention, specially, relates to the prefabricating rack frame that is made of only a column and a cross member without additional components, therefore, shakes can be prevented and structural stability can be attained.

### BACKGROUND ART

[0002] Most shelves can be used for storing or displaying goods at any types of mart or warehouse. The shelf has a structure in which several plates are stacked at a predetermined interval, and was prefabricated for facility of portage, assembly and disassembly.

[0003] Generally, to establish a prefabricating rack, an angle having plural slots can be cut at a predetermined length, and can be fastened by bolts and nuts through the bracket attached to the angle, thus making a shelf frame. A shelf, made of thin steel or wood plate, is placed on the horizontal angle.

[0004] However, such a prefabricating shelf needs plural bolts and nuts to lead troublesome in assembly and disassembly and needs lots of work time. This brings cost increase.

[0005] Furthermore, angles can be distorted by load of goods placed on the shelf after long-term usage. That causes plenty of problems such as an ugly appearance and instability.

[0006] Considering the above problems, an example of the rack frame enabling assembly without special fastening means is disclosed in the Korean Utility Model Publication No. 20-1996-0009841.

[0007] The conventional art is comprised of a column having parallel plural slots and a cross member being assembled with the column. A hook formed at the cross member is inserted into the slots of the column, and the cross member is pressed down, thus completing the assembly between the column and the cross member.

[0008] This technology has the advantage of easy assembly and disassembly since no additional fastening means is required.

[0009] However, the conventional art needs to have a gap between the hook and the slot when the hook is inserted into the slot, because it would lead to a difficult assembly if there was no gap. The gap causes a shaking of the cross member fitted into the column, and it brings structural instability of the prefabricating rack.

[0010] Considering the above problems, the inventor has proposed a prefabricating rack frame in the Korean Open-laid Patent No. 2002-0089286(2002.11.29), in which a cross member is assembled in a force fit with a column to prevent a shake of the rack frame. The rack frame 3 is comprised of plural columns 1 and plural cross members 2, by which rectangular frame is shaped as shown in FIG. 1. A shelf supporter 4 is provided at the column at a predetermined

height, and a glass shelf 5 is placed on the shelf supporter 4, thereby supporting plural glass shelves 5.

[0011] Furthermore, as shown in FIGS. 2 and 3, in each of the hooks 2a, 2b formed at the cross member 2, an inner end of the hook is inclined outward along a direction from top to bottom of the hook. Each hook 2a, 2b fits into each slot 1a, 1b so as to obtain the rigid assembly force. The slot 1a, 1b has a trapezoid, in which the lower side  $S_2$  is smaller than the upper side  $S_1$ . The assembly force of the side surface of each hook 2a, 2b can be increased, which prevents the forward/backward and the right/left shake.

[0012] However, in this structure, the hook 2a, 2b is point-contacted on a very partial lower portion of the column 1, which causes problems of low assembly force.

[0013] Moreover, in the case of the frequent assembly or disassembly of the column 1 and the cross member 2, wear occurs between the slot 1a, 1b and the hook 2a, 2b. That lessens the assembly force, which brings concern about the forward/backward and the right/left shake.

### DISCLOSURE OF INVENTION

[0014] Accordingly, the present invention has been made keeping in mind the above problems occurring in the prior art, and an object of the present invention is to provide a prefabricating rack frame in which the column is fixed with the cross member utilizing minimum fastening means, thus attaining simple and fast assembly and disassembly. The coupling portion of both column and cross member has reinforcement, which causes more rigid assembly force than any prior art and secures the isolation of a shaking of forward/backward, right/left direction and the structural stability, and also shows a satisfactory appearance.

[0015] In order to accomplish those and these objects, the present invention has characteristic in which; a prefabricating rack frame comprises a column made of a steel square tube, a cross member made of a bent steel plate, by which a square is formed, and multiple shelf plates are placed. The prefabricating rack frame is comprised of; the column having plural slots along a longitudinal direction at an even interval; and the cross member having a pair of hooks to be inserted into respective slot, and a location restrictor formed between the upper and the lower hook and bent rectangular to the hook, and tightly contracted on the outer surface of the column.

[0016] Further, it has another characteristic in that the slot is comprised of an upper portion having enough room for the hook to be inserted and having vertical side which is parallel to each other; a lower portion having narrower width than that of the upper portion and which is force-fitted into the hook, and having vertical side which is parallel to each other; and a slant portion formed between the upper portion and the lower portion.

[0017] Further, it has another characteristic in that the slot has an inverse trapezoid shape in which a distance of the upper area is longer than that of the lower area, and has respective parallel portion that is measured from the bottom of each slot, and the hook is force-fitted into the parallel portion.

[0018] Further, it has another characteristic in that the column has a pair of round openings formed at each right

and left of the slot in a parallel way, the location restrictor has a hole at the center thereof and the hole overlaps any of the round openings, in which a screw is inserted to any round opening through the hole.

[0019] Further, it has another characteristic in that a pair of round openings is formed near the slot of the column, the column further has a fixing pin that is comprised of a pin member inserted into any one of the round openings, and a head formed at an end of the pin member that is contacted at the location restrictor of the cross member.

[0020] Further, it has another characteristic in that an inner vertical end of the hook is inclined outward along a direction from top to bottom, and when each hook fits into each slot, the inner vertical end of the hook contrasoes the outer side of the location restrictor against the wall of the column so as to squash.

[0021] Further, it has another characteristic in that the cross member is comprised of a vertical web having the hook and the location restrictor at each longitudinal of the vertical web, and an upper/lower horizontal flange formed at the upper/lower vertical end of the vertical web and bent perpendicular to the vertical web and opposite to the extending direction of the location restrictor.

#### DESCRIPTION OF DRAWING

[0022] The above and other objects, features and other advantages of the present invention will be more clearly understood from the following detailed description taken in conjunction with the accompanying drawings, in which:

[0023] FIG. 1 is schematic views illustrating a configuration of a conventional prefabricating rack frame;

[0024] FIGS. 2 and 3 are views illustrating assembly process of a column and a cross member of FIG. 1;

[0025] FIG. 4 is a perspective view showing an assembly of a column and a cross member according to a first embodiment of the present invention;

[0026] FIG. 5 is a perspective view showing an assembly of a prefabricating rack frame, on which a shelf is placed;

[0027] FIG. 6 is a front view of a slot of the column according to first/second embodiment;

[0028] FIGS. 7 and 8 are a perspective view and a side sectional view of the cross member according to a first embodiment, respectively,

[0029] FIG. 9 is a perspective view showing an assembly of a column and a cross member according to a fourth embodiment;

[0030] FIGS. 10 and 11 are a side sectional view and a top plan view showing an assembly of a column and a cross member of FIG. 9, respectively,

[0031] FIG. 12 is a perspective view showing an assembly of a column and a cross member according to a second embodiment of the present invention;

[0032] FIGS. 13 and 14 are a perspective view and a side sectional view of the cross member according to a second embodiment, respectively;

[0033] FIG. 15 is a perspective view showing an assembly of a column and a cross member according to a second embodiment;

[0034] FIG. 16 is a perspective view showing an assembly of a column and a cross member according to a third embodiment;

[0035] FIG. 17 is a front view of a slot of the column according to a third embodiment;

[0036] FIGS. 18 and 19 are a side sectional view and a top plan view showing an assembly of a column and a cross member of FIG. 16, respectively;

[0037] FIGS. 20 and 21 are plan views showing the assembly of a column and a cross member of FIG. 16; and

[0038] FIGS. 22 and 23 are plan views showing the assembly of a column and a cross member according to a fourth embodiment;

#### BEST MODE

[0039] This invention will be described further by way of exemplary embodiments with reference to the accompanying drawings.

[0040] FIGS. 4 to 11 illustrate a prefabricating rack frame and its accompanying components according to a first embodiment of the present invention, FIGS. 12 to 15 illustrate a prefabricating rack frame and its accompanying components according to a second embodiment of the present invention, FIGS. 16 to 21 illustrate a prefabricating rack frame and its accompanying components according to a third embodiment of the present invention, and FIGS. 22 to 23 illustrate a prefabricating rack frame and its accompanying components according to a first embodiment of the present invention. The same components of the embodiments designate the same reference numbers.

[0041] First, the technology configuration of the first embodiment (FIGS. 4 to 11) and the second embodiment (FIGS. 12 to 15) will be described below.

[0042] The prefabricating rack frame of the present invention is comprised of a column 10 having slot 11 along a longitudinal direction at an even interval, and a cross member 20 in which a pair of the hooks is formed at each end of the body of the cross member 20. A shelf plate P is installed on each cross member 20 in a multistage. A square pipe is used as the column 10 as shown in the Figure, but a round pipe can be employed.

[0043] The slot 11 plays a role as a fitter for the cross member 20, but is used as a receiver of a shelf supporter S to support the shelf plate P.

[0044] The slot 11 can be arranged along from top to bottom at a predetermined interval, and can be formed at a matchable position to the cross member or the shelf plate P.

[0045] The slot has an upper portion 11a, a lower portion 11b, and a slant portion 11c as shown FIG. 6. The upper portion 11a has enough room for the hook 21 of the cross member 20 to be inserted and each vertical side is parallel to each other. The lower portion 11b has narrower width than that of the upper portion 11a into which the hook 21 is force-fitted, and also each vertical side is parallel to each

other. The slant portion **11c** is formed between the upper portion **11a** and the lower portion **11b**.

[0046] In the configuration of the slot **11**, the upper portion **11a** makes easy for the hook **21** to be inserted, the slant portion **1c** leads the hook **21** smoothly into the lower portion **11b**, and the lower portion **11b** takes a firm hold of the neck of the hook **21**, thereby satisfying the assembly easiness and the structural stability.

[0047] At each right and left side of the slot **11**, a round opening **12** is symmetrically provided through which a screw **30** is passed in order to connect the cross member **20** to the column **10**. The symmetric formation of the slot is for inserting the screw **30** into the designated slot depending on the installation position of the cross member **20** or the assembly place of the location restrictor **22**.

[0048] The slot **11** and the round opening **12** are formed at the same height of the opposite surface or the adjacent surface of the square pipe. The cross member **20** is assembled continually in forward/backward or left/right direction to make up a large shelf. A pair of hooks **21** is bent at each longitudinal end of the cross member **20** to be inserted into respective slot **11** of the column **10**.

[0049] Furthermore, an inner vertical end of the hook **21** is inclined outward along a direction from top to bottom of the hook, which facilitates easy fit. More, when each hook fits into each slot, the inner vertical end of the hook **21** contraposes the outer side end of the location restrictor **22** and the upper/lower horizontal flange **27,28** against the wall of the column **10** so as to squash, which prevents the forward-backward free movement. The location restrictor **22** is formed between the upper and the lower hook **21** and is bent rectangular to the hook **21**.

[0050] The location restrictor **22** is tightly contacted to the outer surface of the column **10** so as to prevent the left/right movement of the cross member **20**. At the center of the location restrictor **22** a hole is provided that can be matched with any of the round openings **12**.

[0051] The hole **23** is used for engaging the hole **12** of the column **10** with the hole of the cross member by the screw **30**. The thread fit prevents the unintentional separation of the column **10** from the cross member **20**.

[0052] A buckling prevention means is provided at a portion where the location restrictor **22** is extended from the body of the cross member **20**. As shown FIGS. **7, 8, 13**, and **14**, a pit **24** is formed at the outer corner where each longitudinal end of the cross member **20** meets the foot of the location restrictor **22**. Moreover, a reinforcement rib **25** is provided at the inner corner of the location restrictor **22**, and its configuration counterposes that of the pit **24**, by which the contractual strength of the corner is reinforced. It has greater reinforce effect that the pit **24** and the reinforcement rib **25** are formed perpendicular to the border line of the location restrictor **22**.

[0053] FIGS. **7** and **8** illustrate the cross member **20** adapted to a first embodiment of the present invention.

[0054] The cross member **20** is comprised of a vertical web **26** and an upper/lower horizontal flange **27,28**. The vertical web **26** has the hook **21** and the location restrictor **22** at each longitudinal of the vertical web **26**. The upper/lower horizontal flanges **27,28** are formed at the upper/lower

vertical end of the vertical web **26** and bent perpendicular to the vertical web **26** and opposite to the extending direction of the location restrictor **22**.

[0055] FIGS. **13** and **14** illustrate the cross member **20** adapted to a second embodiment of the present invention.

[0056] The cross member **20** is comprised of a vertical web **26**, an upper horizontal flange **27**, and a lower horizontal flange **28**. The vertical web **26** has a hook **21** and a location restrictor **22** at each longitudinal side of the vertical web **26**. The upper horizontal flange **27** is formed at the upper vertical end of the vertical web **26** and bent perpendicular to the vertical web **26** and opposite to the extending direction of the location restrictor **22**. The lower horizontal flange **28** is formed at the lower vertical end of the vertical web **26** and bent perpendicular to the vertical web **26** and at the same direction of the location restrictor **22**.

[0057] The upper/lower horizontal flange **27, 28**, according to the first, and second embodiment, increase the bending strength of the cross member **20** by the reinforcement of the vertical web **26**. Furthermore, each longitudinal end of the upper/lower horizontal flange **28,28** contact the outer surface of the column **10** accompanying with the location restrictor **22**, thereby preventing the left/right movement of the cross member **20**.

[0058] To implement the present invention, it is clear that only any single flange of the upper/lower flange can be adapted.

[0059] Hereafter, the assembly operation of the first/second embodiment according to the present invention will be described below.

[0060] First, as shown in FIG. **9**, a pair of hooks **21** is inserted into the slot **11**, and the hook **21** is pressed down. Thus, the assembly is accomplished as shown in FIG. **10**.

[0061] Now, it maintains that the surrounding edge of the hook **21** contacts the lower portion **11b** of the slot **11** as shown in FIGS. **6** and **11**. Also, the location restrictor **22** and the upper/lower flange **27,28** are tightly contacted with the outer surface of the column **10**, which prevents the forward/backward and the right/left slight movement.

[0062] According to the above assembly, the hole **23** formed at the location restrictor **22** is matched with any of the round openings **12**.

[0063] At this state, the thread **13** is engaged with the hole **23** and the round opening **12** as shown in FIG. **11** and the coupling between the column **10** and the cross member **20** is accomplished.

[0064] In the present invention, at every assembly portion between the column **10** and the cross member **20**, the above operation is repeated, and the shelf frame having a rectangular shape is formed. As shown in FIG. **5**, a shelf supporter **S** is attached at the middle position of the column **10**, and the shelf plate **P** is laid on the shelf supporter **S**.

[0065] Hereafter, the technical components of the third embodiment will be described below with reference to FIGS. **16** to **21**.

[0066] The column **10** has a distance determining means comprised of a pair of slots **11** and a pair of round openings **12**. The slots **11** are formed along the centerline of the

column 10 at a predetermined interval. A pair of round openings 12 is formed adjacent to the point where the middle between each slot 11 is perpendicularly intersected. The distance determining means can change the distance of each shelf.

[0067] The distance determining means are provided at two side surfaces of the column 10 or at two surfaces adjacent to each of the square pipe column 10.

[0068] As shown in FIG. 17, each slot 11 has a respective parallel portion  $H_1$ ,  $H_2$  that is measured from the bottom of each slot, and a distance of the upper area  $D_1$ ,  $D_2$  is a little bit larger than that of the lower area  $d_1$ ,  $d_2$ .

[0069] The parallel portion  $H_1$ ,  $H_2$  increases the contact size of both slot 11 and hook 21 when the hook 21 is inserted into the slot 11. While the coupling of the column and the cross member depends on point contact in any prior art, the hook 21 of the cross member can be surface-contacted with the parallel portion  $H_1$ ,  $H_2$  to obtain large fastening force.

[0070] Each slot 12 has a distance  $L_1$ ,  $L_2$  from the point where the middle between each slot 11 is perpendicularly intersected

[0071] A pin member 41 of the fixing pin 40 is inserted selectively into any of a pair of round openings 12 depending on the installation direction of the cross member 20 or the position of the location restrictor 22; a head 42 of the fixing member 40 pushes the location restrictor 22.

[0072] The cross member 20 has a pair of hooks 21 formed at each longitudinal end of the body and inserted into the slot 11, and a location restrictor 22 provided between the hook 21 that is bent toward any direction perpendicular to the vertical web 26.

[0073] In the hook 21 as shown in FIGS. 18 and 19, an inner vertical end of the hook is inclined outward along a direction from top to bottom of the hook, which facilitates easy fit into the slot 11.

[0074] As the first embodiment, the cross member 20 has a vertical web 26 and the upper/lower horizontal flanges 27,28 that are bent perpendicular to the vertical web 26 and are opposite to the extending direction of the location restrictor 22. However, any of the upper/lower horizontal flanges 27,28 can be bent at the same direction to the extending direction of the location restrictor 22.

[0075] The cross section of the location restrictor 22 and the upper/lower horizontal flange 27,28 has a rectangular shape that is fully contacted on the one surface of the square pipe column.

[0076] The fixing pin 40 is coupled into the round opening 12 to push in the location restrictor 22. That is, the hook 21 is coupled with the slot 11 and the pin member 41 of the fixing pin 40 is inserted into the round opening 12 provided above the location restrictor 22. The head 42 of the fixing pin 40 presses the location restrictor 22 so as to prevent the free movement of the location restrictor 22.

[0077] The pin member 41 has a fastigated shape to facilitate easy fit, and the thread portion is formed around the pin member 41 so it will not free from the round opening 12.

[0078] A pair of hooks 21 is inserted into the slots 11 and is pressed down as shown in FIG. 16, the assembly is

accomplished as shown in FIGS. 18 and 19. At this time, both sides of the hook 21 are tightly contacted to the parallel portion  $H_1$ ,  $H_2$  of the slot 11, and no free movement takes place owing to the upper/lower horizontal flange 27, 28 and the location restrictor 22 pressing the area below the round opening 12.

[0079] At this state, the pin member 41 of the fixing pin 40 is pressed into the round opening 12, the thread portion 43 is crushed, and the head of the fixing pin 40 presses the location restrictor 22, thus completing the assembly.

[0080] In the case of the separation of the cross member 20 from the column 10, a tool such as a flat driver is inserted into a gap between the head 42 and the outside surface of the cross member 20 so as to push aside the fixing pin 40. The fixing pin 40 can be pulled out from the round opening 12.

[0081] Next, the cross member 10 is pushed upward so as to extract the hook 21 from the slot 11. Thus, the cross member 20 is easily separated from the column 10.

[0082] FIGS. 22 and 23 illustrate the fourth embodiment according to the present invention. The round pipe is used as the column 10.

[0083] The location restrictor 22 and both longitudinal ends of the upper/lower horizontal flange 27,28 are shaped as an arc to tightly contact the round tube shape cross member 10. Moreover, the inner side of the head 42 of the fixing pin 40 is configured as an arc so as to push the location restrictor 22. The rest of the configuration and operation are the same as those of the previous described embodiment. Therefore, the detailed description will be omitted for brevity, denoting the same reference numerals of the same components described in the previous embodiment.

[0084] Although the preferred embodiments of the present invention have been disclosed for illustrative purposes, those skilled in the art will appreciate that various modifications, additions and substitutions are possible, without departing from the scope and spirit of the invention as disclosed in the accompanying claims.

#### INDUSTRIAL APPLICABILITY

[0085] According to the present invention, the rectangular rack frame is accomplished by an assembly in which the column is fixed with the cross member that utilizes minimum fastening means, thus attaining simple and fast assembly and disassembly. The coupling portion of both column and cross member has reinforcement, which causes more rigid assembly force than any prior art, and secures the isolation of a shaking of forward/backward, right/left direction and the structural stability, and also shows a satisfactory appearance.

[0086] In the cross member, the flange, the location restrictor, and the upper horizontal flange can tightly contact with the outer surface of the column. This brings the inventive rack frame by which a right/left movement can be perfectly prevented.

[0087] Furthermore, while the coupling of the column and the cross member depends on point contact in any prior art, in the present invention the hook of the cross member can surface-contact with the slot of the column to obtain big fastening force.



[0088] Therefore, according to the present invention, easy assembly and disassembly can be secured, and structure stability can be ensured by the isolation of forward/backward, left/right shaking of the components, and also shows the satisfactory appearance.

1. A prefabricating rack frame comprised of a column made of a steel square tube, a cross member made of a bent steel plate, by which a square is formed, and multiple shelf plates are placed, the prefabricating rack frame comprising;

the column having plural slots along a longitudinal direction at an even interval; and

the cross member having a pair of hooks to be inserted into respective slots, and a location restrictor formed between the upper and the lower hook and bent rectangular to the hook, and tightly contracted on the outer surface of the column.

2. The prefabricating rack frame as set forth in claim 1, wherein the slot is comprised of an upper portion having enough room for the hook to be inserted and having vertical sides which are parallel to each other; a lower portion having narrower width than that of the upper portion and which is force-fitted into the hook, and having vertical sides which are parallel to each other; and a slant portion formed between the upper portion and the lower portion.

3. The prefabricating rack frame as set forth in claim 1, wherein the slot has an inverse trapezoid shape in which a distance of an upper area is longer than that of a lower area, and has respective parallel portion that is measured from the bottom of each slot, and the hook is force-fitted into the parallel portion.

4. The prefabricating rack frame as set forth in claim 1, wherein the column has a pair of round openings formed at each right and left of the slot in a parallel way, the location restrictor has a hole at the center thereof and the hole overlaps any of the round openings, in which a screw is inserted to any round opening through the hole.

5. The prefabricating rack frame as set forth in claim 1, wherein a pair of round openings is formed near the slot of the column, the column further has a fixing pin that is comprised of a pin member inserted into any one of the round openings, and a head formed at an end of the pin member that is contacted at the location restrictor of the cross member.

6. The prefabricating rack frame as set forth in claim 4, wherein a thread portion is formed around the circumstance of the pin member, and the pin member has a fastigated point.

7. The prefabricating rack frame as set forth in claim 1, wherein an inner vertical end of the hook is inclined outward along a direction from top to bottom, and when each hook fits into each slot, the inner vertical end of the hook contraposes the outer side of the location restrictor against the wall of the column so as to squash.

8. The prefabricating rack frame as set forth in claim 1, wherein the cross member further has a pit and a reinforcement rib; the pit is formed at the outer corner where each longitudinal end of the cross member meets the foot of the location restrictor; and a reinforcement rib is provided at the inner corner of the location restrictor and its configuration counterposes to that of the pit.

9. The prefabricating rack frame as set forth in claim 8, wherein the pit and the reinforcement rib are formed perpendicular to the border line of the location restrictor.

10. The prefabricating rack frame as set forth in claim 1, wherein the cross member is comprised of a vertical web having a hook and the location restrictor at each longitudinal end of the vertical web, and an upper/lower horizontal flange formed at the upper/lower vertical end of the vertical web and bent perpendicular to the vertical web and opposite to the extending direction of the location restrictor.

11. The prefabricating rack frame as set forth in claim 1, wherein the cross member is comprised of a vertical web having a hook and the location restrictor at each longitudinal end of the vertical web; an upper horizontal flange formed at the upper vertical end of the vertical web and bent perpendicular to the vertical web and opposite to the extending direction of the location restrictor; and a lower horizontal flange formed at the lower vertical end of the vertical web and bent perpendicular to the vertical web and at the same direction of the location restrictor.

12. The prefabricating rack frame as set forth in claim 10, wherein a square pipe is used as the column, and the cross section of the location restrictor and the upper/lower horizontal flange has a rectangular shape that is fully contacted to the one surface of the square pipe column.

13. The prefabricating rack frame as set forth in claim 10, wherein a round pipe is used as the column, and the cross section of the location restrictor and the upper/lower horizontal flange has an arc that is fully contacted to the one surface of the round pipe column.

\* \* \* \* \*