

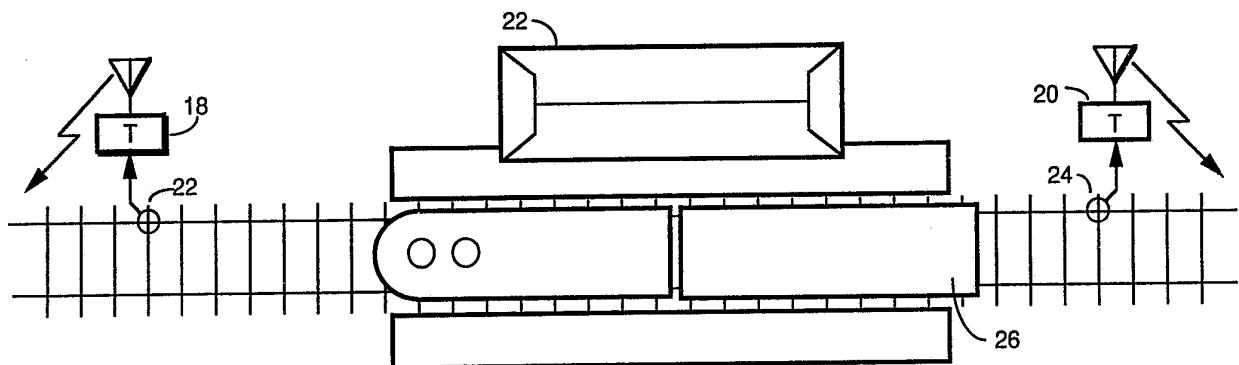

INTERNATIONAL APPLICATION PUBLISHED UNDER THE PATENT COOPERATION TREATY (PCT)

<p>(51) International Patent Classification ⁵ : G08B 5/22, G08G 1/123 H04Q 7/00, 9/00</p>	A1	<p>(11) International Publication Number: WO 93/13503</p> <p>(43) International Publication Date: 8 July 1993 (08.07.93)</p>
<p>(21) International Application Number: PCT/US92/07394</p> <p>(22) International Filing Date: 31 August 1992 (31.08.92)</p> <p>(30) Priority data: 812,143 23 December 1991 (23.12.91) US</p> <p>(71) Applicant: MOTOROLA, INC. [US/US]; 1303 East Algonquin Road, Schaumburg, IL 60196 (US).</p> <p>(72) Inventors: DULANEY, Randi, Lisa ; 11770 Island Lakes Lane, Boca Raton, FL 33498 (US). ROLLINS, Thomas, James ; 9928 Moss Pond Drive, Boca Raton, FL 33496 (US). RUETZ, Marshall, Ray ; 2564 S.E. 13 Street, Pompano Beach, FL 33062 (US). GILBERT, John, Marshall ; 1300 E. Algonquin Road, #20, Schaumburg, IL 60173 (US). BOCCI, Paul, M. ; 23W732 W. Pine, Roselle, IL 60172 (US).</p>		<p>(74) Agents: KOCH, William, E. et al.; Motorola, Inc., Intellectual Property Dept., 1500 N.W. 22nd Avenue, Boynton Beach, FL 33426-8292 (US).</p> <p>(81) Designated States: CA, JP, KR, European patent (AT, BE, CH, DE, DK, ES, FR, GB, GR, IE, IT, LU, MC, NL, SE).</p> <p>Published <i>With international search report.</i></p>

(54) Title: COMMUTER NOTIFICATION SYSTEM FOR MASS TRANSIT APPLICATIONS



(57) Abstract

A commuter notification system for use in mass transit systems which provide a plurality of predetermined transit destinations (22) and one or more transit vehicles (26) for carrying commuters between the predetermined transit destinations (22) comprises transmitters (18, 20, 50) located in proximity to the predetermined transit destinations (22), for transmitting notification signals identifying the transit destinations (22), and notification receivers (40), carried by the commuter and responsive to the transmitted notification signals, for alerting the commuter of the arrival of the transit vehicle (26) at a preselected transit destination (22).

FOR THE PURPOSES OF INFORMATION ONLY

Codes used to identify States party to the PCT on the front pages of pamphlets publishing international applications under the PCT.

AT	Austria	FR	France	MR	Mauritania
AU	Australia	GA	Gabon	MW	Malawi
BB	Barbados	GB	United Kingdom	NL	Netherlands
BE	Belgium	GN	Guinea	NO	Norway
BF	Burkina Faso	GR	Greece	NZ	New Zealand
BG	Bulgaria	HU	Hungary	PL	Poland
BJ	Benin	IE	Ireland	PT	Portugal
BR	Brazil	IT	Italy	RO	Romania
CA	Canada	JP	Japan	RU	Russian Federation
CF	Central African Republic	KP	Democratic People's Republic of Korea	SD	Sudan
CG	Congo	KR	Republic of Korea	SE	Sweden
CH	Switzerland	KZ	Kazakhstan	SK	Slovak Republic
CI	Côte d'Ivoire	LI	Liechtenstein	SN	Senegal
CM	Cameroon	LK	Sri Lanka	SU	Soviet Union
CS	Czechoslovakia	LU	Luxembourg	TD	Chad
CZ	Czech Republic	MC	Monaco	TG	Togo
DE	Germany	MG	Madagascar	UA	Ukraine
DK	Denmark	ML	Mali	US	United States of America
ES	Spain	MN	Mongolia	VN	Viet Nam
FI	Finland				

**COMMUTER NOTIFICATION SYSTEM FOR
MASS TRANSIT APPLICATIONS**

5 **BACKGROUND OF THE INVENTION**

FIELD OF THE INVENTION:

The present invention relates generally to the field of selective call signaling systems, and more particularly to a selective call signaling system providing commuter
10 notification in mass transit systems.

DESCRIPTION OF THE PRIOR ART:

A variety of mass transit systems provide a multiplicity of predetermined commuter destinations with
15 one or more transit vehicles carrying the commuters between the predetermined commuter destinations. Examples of such mass transit systems include passenger rail systems providing service between rail stations located within a city, or between stations located in different cities,
20 including specialized passenger rail systems such as subways, elevated railroads, and monorail systems. Other examples of mass transit systems include bus systems, including inter-city and intra-city bus transit systems, and people mover systems which operate on fixed, dedicated
25 routes such as those providing feeder services to bus or train routes within cities and in airports. In order for a commuter to effectively utilize such mass transit systems, the location and sequence of the transit stations, either rail stations, and bus stations, or stops, along a
30 particular rail or bus route must be known to insure that the commuter does not pass up or miss the destination which is desired.

In the case of bus transit systems, most bus transit systems offer a multiplicity of routes which include many
35 predetermined destinations, or stops, where the commuter can enter or depart the buses. When the route travelled by the commuter is unfamiliar, there is a very great

opportunity for the commuter to miss the desired stop, and the problem is often compounded when a transfer between bus routes must occur prior to the commuter arriving at the final destination. While announcements are generally made
5 by the bus driver of the upcoming stop, such announcement is often missed by the commuter when the commuter's concentration is distracted by such things as road noise, passenger conversations or concentration on reading.

In the case of passenger rail systems, the same or
10 similar problems as described above for bus systems are encountered by the commuters of the passenger rail systems. Additionally, because passenger rail systems often provide travel between communities which are widely separated, resulting in a significant amount of time being encountered
15 during travel, the commuter is apt to find a source of distraction to occupy the time during travel, such as reading the newspaper, working on work brought home from the office, or in resting, and in some instances, falling asleep. The commuters need to remain alert so that their
20 destination is not missed, and again, while announcements are generally made by the train operator of the upcoming stop, such announcement is often missed due to the distractions of background noise due to rail travel, or the commuter's preoccupation with talking, reading or sleeping.

25 There is a need to provide a better means for notifying the commuter of the upcoming destination, which overrides such distractions as those mentioned previously. By providing a better means for notifying the commuter, the commuter is better assured of finding his destination
30 through the distractions.

SUMMARY OF THE INVENTION

In accordance with one aspect of the present invention, a commuter notification system for use in mass
35 transit systems which provide a plurality of predetermined commuter destinations and one or more transit vehicles for carrying the commuters between the predetermined commuter

destinations comprises transmitters located at the predetermined commuter destinations for transmitting notification signals identifying the commuter destinations, and notification receivers carried by the commuter and
5 responsive to the transmitted notification signals for alerting the commuter of the arrival of the transit vehicle at a preselected commuter destination.

In accordance with another aspect of the present invention,
10

BRIEF DESCRIPTION OF THE DRAWINGS

FIG. 1 is a pictorial drawing of a commuter notification system for use in mass transit applications in accordance with a first embodiment of the present
15 invention.

FIG. 2 is a pictorial drawing of a commuter notification system in accordance with a second embodiment of the present invention.

FIG. 3 is a pictorial drawing of a commuter notification system in accordance with a third embodiment
20 of the present invention.

FIG. 4 is a pictorial drawing of a commuter notification system in accordance with a fourth embodiment of the present invention.

FIG. 5 is an electrical block diagram of the notification transmitter suitable for use with the present
25 invention.

FIG. 6 is an electrical block diagram of the notification receiver suitable for use with the present
30 invention.

FIG. 7 is an electrical block diagram of an alternate embodiment of the notification receiver of FIG. 6.

FIG. 8 is a pictorial drawing of the notification receiver of FIG. 6.

FIG. 9 is a memory map depicting the destination information present in the notification receiver of FIG. 6.
35

FIG. 10 is a flow diagram illustrating the destination selection operation of the notification receiver of FIG 8.

FIG. 11 is a flow diagram illustrating a first embodiment of the operation of the notification receiver of
5 FIG. 6.

FIG. 12 is a flow diagram illustrating an embodiment of the programming operation of the notification receiver of FIG. 6.

FIG. 13 is a flow diagram illustrating an alternate
10 embodiment of the operation of the notification receiver of FIG. 6.

FIG. 14 is a flow diagram illustrating an embodiment of the operation of the notification transmitter in accordance with the present invention.

15

DESCRIPTION OF THE PREFERRED EMBODIMENTS

FIG. 1 is a pictorial drawing of a commuter notification system for use in mass transit systems, such as in a commuter railroad transportation system, in
20 accordance with a first embodiment of the present invention. Commuters regularly board the mass transit vehicles, such as a passenger train car, at one station, such as station A, for travel to another predetermined commuter destination, such as station N, located in another
25 part of the city, and in some instances in another city where the commuter works during the day. Depending upon the distance traveled, the commuter spends a significant amount of time traveling, generally between one-half and one hour each way to and from work. During this time, the
30 commuter may catch up on work, talk with fellow passengers, or simply rest. In order that the commuter be allowed to fully participate in whatever activity the commuter selects, the commuter notification system in accordance with the present invention provides a convenient means of
35 alerting the commuter of the transit vehicles arrival at the destination station the commuter has preselected

before, or upon boarding the transit vehicle, as will be described in detail below.

In the commuter notification system 10 in accordance with the first embodiment of the present invention, shown
5 in FIG. 1, the commuter carries a notification receiver which is programmed by the commuter to select the destination station at which departure from the transit vehicle is desired. Each station, A through N, includes one or more relatively low power identification
10 transmitters 12, 14, 16 which preferably periodically transmit encoded notification signals uniquely identifying each destination, or station. The transmitters provide a transmitted output signal which is of sufficient power to be received within the transit vehicle by the notification
15 receiver either at a predetermined distance from the destination station, such as at a distance of one or two miles from the destination station, or at a predetermined time prior to arriving at the destination station, such as five minutes away. When the notification receiver receives
20 the encoded notification signal identifying the preselected destination station, the commuter is alerted, preferably by a tactile alert, so as not to disrupt other commuters. Because the commuter is alerted prior to arrival at the destination station, the commuter has time to conclude the
25 current activity, be it putting away work, setting aside a newspaper or magazine, or concluding a conversation, thereby being ready to depart from the transit vehicle when the vehicle arrives at the destination station. Each of the notification transmitters may be interconnected to a
30 system controller, one operation of which is described below in FIG. 12

FIG. 2 is a pictorial drawing of the commuter notification system in accordance with a second embodiment of the present invention. In the embodiment of FIG. 2,
35 multiple transmitters 18, 20 are positioned at fixed distances from the destination station 22. The distances again correspond to a predetermined distance or time prior

to arriving at the destination station, as described above. However, unlike transmitters 12, 14, 16 which would continuously transmit the encoded notification signal at periodic time intervals, the notification transmitters 18, 20 do not transmit the notification signals until first triggered by the presence of the transit vehicle 26 using such well known methods as trackside switches 22, 24 or field disturbance sensors. Transmitters 18, 20 can generally be lower powered than that required for transmitters 12, 14, 16, because they provide coverage over a much smaller area. When triggered, the transmissions can be either continuous during the time the transit vehicle 26 is passing, or can be periodically generated, as described above.

FIG. 3 is a pictorial drawing of the commuter notification system in accordance with a third embodiment of the present invention. The embodiment of FIG. 3 provides a commuter notification within other types of transit systems, such as bus, or people mover transit systems which often provide many relatively closely positioned destinations. The commuter notification system when so utilized is especially useful because the commuter may be utilizing buses on routes unfamiliar to the commuter. As described above, with notification transmitters, such as transmitters 30, 32, 34 and 36, are positioned either ahead of each destination, such as the bus stop, or at the destination. The commuter is alerted that the current destination that is being approached, or at which the transit vehicle has stopped, is in fact the desired destination to depart, even when signs identifying the location are not immediately visible.

FIG. 4 is a pictorial drawing of the commuter notification system in accordance with a fourth embodiment of the present invention. As shown in FIG. 4, the notification receiver 40 can receive information both from a notification transmitter 42 which may be operating on one frequency, and can also receive conventional paging

messages which are delivered by a paging transmitter 44 on a different frequency, as will be described in detail below. The paging messages are generally inputted into the paging system through the public switched telephone network where the messages are then coupled into a paging terminal 46 which processes the messages for transmission, as is well known to one of ordinary skill in the art.

FIG. 5 is an electrical block diagram of the notification transmitter constructed in accordance with the present invention. The notification transmitter 50 comprises a memory 52 which stores the predetermined notification information, or transit destination ID, identifying each of the transit destinations. The memory 52 can be implemented using a programmable read only memory (PROM), or can be hardwired using DIP (dual in-line package) switches or jumpers to selectively define the destination IDs. The memory 52 couples to a controller 54 which controls the operation of the notification transmitter, including such operations as recovering the stored destination ID, and controlling the transmission thereof. The controller 54 can be implemented using a microcomputer, and can also be constructed using discrete logic functions, the design of which are well known in the art. A timing signal generator 56 is coupled to the controller, and provides reference frequency signals for operation of the controller. The timing signal generator 56 can generate either continuous or periodic timing signals which can be utilized by the microcomputer or discrete logic controller to provide continuous or periodic transmissions of the destination ID. The controller 54 controls the keying of the transmitter 58, and provides a serial stream of information corresponding to the destination ID to the input of a modulator 60. The modulator 60 modulates a carrier signal utilizing any of a number of well known modulation techniques, such as amplitude (AM) or frequency (FM) modulation techniques. The modulated carrier signal is coupled into the input of

the transmitter 58 which processes the carrier signal in a manner well known in the art for transmission.

When trackside sensing is employed, the sensing signal can be generated by trackside switches as previously described which are coupled into the controller 54 for controlling the transmission of the destination ID, as described above. When a field disturbance sensor 62 is utilized, the output of the sensor is coupled to the controller 54 which then controls the transmission of the destination ID, as described above. A data terminal 48 can also be coupled to the controller to enable commuter control of destination information reprogramming, as will be described below.

FIG. 6 is an electrical block diagram of the notification receiver in accordance with the present invention. The notification receiver 40 comprises an antenna 64 for intercepting the transmitted notification, or destination ID signals which are coupled to the input of a receiver section 66. The receiver section may provide for reception of transmissions on a single reception frequency, or as will be further described below on multiple reception frequencies. When multiple frequency reception is provided, a frequency synthesizer 67 enables the generation of the multiple reception frequencies in a manner well known in the art. The receiver receives and demodulates the transmitted notification signals, preferably frequency modulated data signals, providing at the output of the receiver a stream of binary data signals corresponding to the destination IDs transmitted from any particular destination location. The binary data signals are coupled into the input of the decoder/controller 68 which processes the signals, in a manner well known in the art, comparing the received destination IDs with the predetermined destination ID corresponding to the destination to which the commuter has preselected. A memory 70, coupled to the decoder/controller 68, includes a table of destination IDs, or addresses, which are stored in

the destination memory 74 section of the memory 70, and which correspond to destinations along the transit route being travelled, as will be described below. Selector switches 76 are provided to enable the selection of one or more destination addresses identifying destinations at which the commuter wishes to be notified. A display 78 is provided which is utilized to display the destination information stored in the destination memory 74, thereby enabling the commuter to readily select the destination at which an alert is desired, as will be described below. The decoder/controller 68 compares the received destination IDs with the predetermined destination address selected by the commuter from the destination memory 74, and when a match is detected, the decoder/controller 68 generates an alert enable signal which is coupled to the input of a sensible alerting device, such as the tactile alerting device 80. The tactile alerting device 80 preferably provides a silent vibratory output alerting the commuter that the destination selected is being approached.

When the notification receiver is used to provide both destination notification alerting and paging capability, the addresses assigned to the receiver for use in the local paging system are stored in the address memory 72 portion of memory 70. The decoder/controller 68 then controls the generation by the frequency synthesizer 67 of the notification system frequency or the paging system frequency, to enable selectively receiving signals on the paging channel or the notification system channel. A power switch 82 is coupled to the decoder/controller 68 and is used to control the supply of power to the receiver section 66, thereby providing a battery saving function, as is well known in the art for use with paging receivers. When the paging channel is selected, the received paging address signals are processed by the decoder/controller 68, and when a paging address signal is detected which corresponds to an assigned address of the notification receiver, the decoder/controller 68 generates an alert enable signal

which can be coupled to an audible alerting device 84, such as an audible transducer, to provide an audible alert, a visual alerting device, such as an LED, to provide a visual alert, or can be coupled to the tactile alerting device 80 to provide a silent alert. Selection of either audible, visual or silent alerting is provided by the selector switches 76 in a manner well known in the art.

The controller/decoder 68 of FIG. 6 can be constructed utilizing a microcomputer as shown in FIG. 7. FIG. 7 is an electrical block diagram of a microcomputer based decoder/controller suitable for use in the notification receiver of FIG. 6. As shown, the microcomputer 68 is preferably an MC68HC05 microcomputer, such as manufactured by Motorola, Inc. The Microcomputer 68 includes an oscillator 100 which generates the timing signals utilized in the operation of the microcomputer. A crystal, or crystal oscillator (not shown) is coupled to the inputs of the oscillator 100 to provide a reference signal for establishing the microcomputer timing. A timer/counter 102 couples to the oscillator 100 and provides programmable timing functions which are utilized in controlling the operation of the receiver. A RAM (random access memory) 104 is utilized to store variables derived during processing, as well as to provide storage of message information which is received during operation as a paging receiver. A ROM (read only memory) 106 stores the subroutines which control the operation of the receiver, as will be described in further detail below. It will be appreciated that in many microcomputer implementations, the PROM memory area can be provided by an EEPROM (electrically erasable programmable read only memory). The oscillator 100, timer/counter 102, RAM 104 and ROM 106 couple through the address/data/control bus 108 to the central processing unit (CPU) 110 which performs the instructions and controls the operations of the microcomputer 68.

The demodulated data from the receiver is coupled into the microcomputer 68 through input/output (I/O) bus 112A.

The demodulated data is process by the CPU 110, and when the received data is the same as the notification address or paging address stored in the memory 70 which couples into the microcomputer through I/O bus 112B, the message, if any, is received and stored in RAM 104. Recovery of the stored message, and selection of the predetermined destination address, is provided by the switches which are coupled to I/O port 112A. The microcomputer recovers the stored message, or the destination table information from RAM 104 and directs the information over the data bus 108 to the display driver 114 which processes the information and formats the information for display by a display such as an LCD (liquid crystal display). At the time a paging address is received, an alert signal is generated which can be routed through the data bus 108 to the alert generator 116 which generates the alert signal which is coupled to the audible or visual alert device as described above, or when a notification address is received, the microcomputer generates an notification alert enable signal which is coupled through data bus 108 to I/O port 112B to enable generation of a vibratory, or silent alert.

Battery saver operation is control by the CPU 110 with battery saving signals which are directed over the data bus 108 to the I/O port 112A which couples to the power switch. Power is periodically supplied to the receiver to enable decoding of the received notification and paging address signals and any message information which is directed to the receiver.

When the silent mode of operation is selected during paging address decoding, the alert enable signal is directed over the data bus 108 to the I/O port 112B which couples to the vibrator driver. Frequency switching is also control by the microcomputer 68 through frequency control switching signals which are provided through I/O port 112A, thereby enabling reception of notification addresses on one channel and paging addresses on another channel.

FIG. 8 is a pictorial drawing of the notification receiver 40 suitable for use in the present invention. The notification receiver 40 is preferably a portable device which may or may not include a clip to enable carrying by the commuter, and includes a display 78 which is preferably a multi-line display, such as a four line LCD display, as shown. Selector switches for controlling the operation of the receiver includes at least a switch 76A for reading messages which are received and stored, a switch 76B which is a function button for selecting the function menu and the particular functions selected, and a cursor control switch 76C which enables selection of functions presently being displayed on the display.

In an alternate embodiment, a non-display, tone only receiver can also be utilized to provide a low cost alternative to a receiver having a display. Destination selection using such a receiver is described below.

The display of FIG. 8 depicts a typical screen which would enable the commuter to select a predetermined destination, for example, such as in a bus transit system. The information displayed will vary for the type of transit system, and represents a minimum information display which would enable easy selection of transit destinations. The first display column 120 lists the bus route, the second column 122 the stop number along the route, and the third column 124 identifies the destination location. The route selection menu is selected using, for example, function button 76B. The cursor control switch 76C enables the commuter to select the predetermined destination by moving a displayed cursor 126, which as shown, is highlighting the stop information. Selection of the particular destination using the function button 76B results in the recovery of the destination ID, or address assigned to the selected destination, as will be described below.

FIG. 9 is a typical memory map depicting the destination information present in the notification receiver of FIG. 6, and which is displayed in FIG. 8. A

table of destinations is stored within the notification receiver, which for example, includes the route number 120, stop number 122 and destination identification 124 for each destination for which selection is provided in the table.

5 When a destination is selected, the destination address 128 which corresponds to the code assigned to the selected destination notification transmitter is recovered from the table, and temporarily stored for use in decoding the received notification signals identifying the transit
10 destinations.

While the notification receiver has been shown and described above which utilizes an alphanumeric display for the display of destination information, other receiver types, such as one capable of displaying numeric
15 information can also be utilized to provide simple selection of destination information. One such method of providing simple selection is to provide a card listing destination names and a destination number assigned thereto. The destination would then be selected by simply
20 advancing a displayed number to the number corresponding to the desired destination, thereby enabling the recovery of the destination address from memory, as described above.

When a tone only notification receiver is utilized, destination selection would be provided at the point of
25 departure. The data terminal shown in FIG. 5 can be configured to issue the ticket, and at the same time, can program the destination information into the notification receiver using over-the-air reprogramming as described in detail below. Multiple destination alerts can be
30 programmed in this manner such as would be required when transfers from one mass transit vehicle to another is required.

FIG. 10 is a flow diagram illustrating the destination selection operation of the notification receiver of FIG. 8.
35 When the display is showing the standby screen, the commuter scrolls through the menu displayed on the standby screen to select the destination alarm mode using the mode

switches which provide cursor control, at step 200. When the destination alarm mode menu is selected, the commuter presses the function button, at step 202, to select the destination alarm mode, whereupon the destination selection screen is displayed, at step 204. The commuter then scrolls through the selection screen menu using the mode switches, at step 206, selecting the appropriate destination, followed by pressing the function button, at step 208. When an additional destinations are desired, such as is often the case in bus transit systems where transfers prior to the final destination are common, the commuter repeats the selection process, steps 204-208. When all destinations have been selected at step 210, the commuter scrolls to the end of the selection menu using the mode switches, whereupon the destination alarm mode is activated, at step 212. Once the destination alarm mode is activated, the standby screen is again displayed, at step 214.

FIG. 11 is a flow diagram illustrating a first embodiment of the operation of the notification receiver of FIG. 6. When the standby screen is present, at step 216, and the alarm mode has been activated, at step 218, the first destination address is recovered, at step 220, and compared with the received data, at step 222. When the received data matches the destination address recovered, at step 224, indicating the transit vehicle is approaching the selected destination, a lockout timer is set, at step 226, and a sensible alert is generated, at step 228. The lockout timer insures that once the predetermined destination address is detected, no further detection of the same destination address is allowed for the duration of the lockout time, thereby preventing multiple alerts from being generated, should the commuter remain within range of the notification transmitter during the predetermined time interval. When the lockout timer times out, at step 230, and there are no additional destination addresses selected, at step 232, decoding is suspended, and operation returns

to step 218 to await the next activation of the alarm mode. When additional destination addresses have been preselected, at step 232, the next destination address is recovered, at step 236, whereupon steps 222 through 232 are
5 repeated as described above.

In some instances, it may be desirable to generate multiple alerts to insure that the commuter has been properly alerted. This is especially true when the commuter may have fallen asleep and may fail to respond to
10 the first alert generated. Such a call reminder feature is described in U.S. Patent No. 4,701,759 issued October 20, 1987 to Nadir et al., which is assigned to the assignee of the present invention and which is hereby incorporated by reference herein.

15 FIG. 12 is a flow diagram illustrating one embodiment for reprogramming the destination tables stored within the notification receiver of FIG. 6. It will be appreciated that in most mass transit systems, routes and destinations are often routinely changed over a period of time to
20 accommodate different patterns of usage. This is especially true when considering mass transit systems which are not constrained to fixed routes, such as bus systems. As a result, route and destination information, and in many cases, destination addresses corresponding thereto are
25 routinely changed, requiring that the commuter be informed of the changes. When a destination information card is provided which indicates the information required in selecting destinations, the mailing of a new destination information card would generally suffice. However, when
30 destination information is preprogrammed into the notification receiver, such changes become more complicated. One method to overcome this problem is shown in FIG 12, which allows for over-the-air reprogramming of the destination information. Such over-the-air
35 reprogramming is described in U.S. Patent No. 4,839,628 issued June 13, 1989 to Davis et al., entitled "Paging Receiver Having Selectively Protected Regions of Memory",

and U.S. Patent No. 5,012,234 issued April 30, 1991 to Dulaney et al., entitled "User Activated Memory Programming Authorization in a Selective Call Receiver", both of which are assigned to the assignee of the present invention, and
5 which are hereby incorporated by reference herein.

In the preferred embodiment of the present invention, the commuter is notified by the mass transit system operator of changes in the destination information, and the commuter accesses the mass transit system controller either
10 by phone or through the use of the data terminal described above which is located at one or more of the destination locations, at step 238, to request an update of the current destination information, at step 240. The system controller then sends out a unique notification signal
15 which is transmitted by the notification transmitter, or over the paging system when the receiver is capable of receiving information over the paging channel, to prepare the receiver for reprogramming the destination table information, at step 242. The reconfiguration information
20 changing the destination table is then transmitted again either by the notification transmitter or over the paging system, at step 244, whereupon the information is received by the receiver, at step 246, and the memory storing the table is reconfigured, at step 248. Following memory
25 reconfiguration, the commuter is alerted that the reconfiguration is complete, at step 250.

FIG. 13 is a flow diagram illustrating an alternate embodiment of the operation of the notification receiver of FIG. 6 which is capable of receiving information on at
30 least two different channels, or frequencies. When power is turned on, at step 252, the receiver is tuned to the first programmed frequency, at step 254, such as that used for transmitting the notification information. When data is present on the channel selected, at step 256, the data
35 is compared with the destination address selected by the commuter, at step 258. When the received data matches the destination address selected, at step 258, the receiver

checks to see if an alert was previously generated, at step 260. When an alert was not previously generated, at step 260, an alert is generated, at step 262, alerting the commuter of the approach of the transit vehicle to the selected destination location. When an alert was
5 previously generated, at step 260, flow returns to step 252.

When data is not present on the first channel, at step 256, the receiver is tuned to the second programmed
10 frequency, at step 266, such as that of the paging channel. When data is present on the channel selected, at step 266, the data is compared with the paging address, at step 268. When the received data matches the paging address, at step 268, the receiver then receives any message information and
15 generates a sensible, such as an audible alert, at step 262. Flow then returns to step 252.

FIG. 14 is a flow diagram illustrating an embodiment of the operation of the notification transmitter in accordance with the present invention, corresponding to the
20 operation of the commuter notification system of FIG. 2. When the train, or other commuter vehicle, is detected via a trackside switch or field disturbance sensor, at step 264, a transmission timer is set, at step 266. The transmission timer insures the notification transmitter
25 transmits the notification signals for a period of time sufficiently long for all sections of the transit vehicle to receive the transmitted notification signals. The transmitter is then keyed, at step 268, and the destination address is either continuously or periodically transmitted.
30 When the transmission timer times out, at step 270, the transmitter is de-keyed, and transmission of the notification signals ceases, at step 272.

A commuter notification system has been described which provides a convenient means for notifying a commuter
35 that the transit vehicle in which the commuter is traveling is approaching a preselected destination. By alerting the commuter prior to arrival at the preselected destination,

the commuter has time to conclude any current activity, be it putting away work, setting aside a newspaper or magazine, or concluding a conversation, thereby enabling the commuter to be ready to depart from the transit vehicle
5 when the vehicle arrives at the destination. The commuter notification system also insures that the commuter does not miss the preselected destination, due either to being asleep, distracted, or otherwise unaware that the transit
10 vehicle has arrived at the preselected destination. Such an error could result in a significant amount of time and expense to return to the preselected destination once the preselected destination has been missed.

We claim:

Claims

1. A commuter notification system for use in mass transit systems providing a plurality of predetermined transit destinations and one or more transit vehicles for carrying commuters between the predetermined transit destinations, said commuter notification system comprising:
- 5 transmitting means, located in proximity to the predetermined transit destinations, for transmitting notification signals identifying the transit destinations;
- 10 and
- notification receiving means, carried by the commuter and responsive to the transmitted notification signals, for alerting the commuter of the arrival of the transit vehicle
- 15 at a preselected transit destination.
2. The commuter notification system according to claim 1, wherein said transmitting means comprises:
- means for storing a predetermined destination ID
- 20 identifying the predetermined transit destination;
- means for modulating the predetermined destination ID onto a predetermined carrier signal to provide the notification signals; and
- a transmitter, coupled to said means for modulating,
- 25 for transmitting the notification signals modulated onto the carrier signal.
3. The commuter notification system according to claim 2, wherein said means for transmitting further comprises:
- 30 timing means for generating timing signals; and
- controller means, responsive to the timing signals, for controlling the transmission of the notification signals.

4. The commuter notification system according to claim 3, wherein the timing signals are generated periodically thereby enabling the periodic transmission of the notification signals.

5

5. The commuter notification system according to claim 3, further comprising transit vehicle detection means, coupled to said controller means, for detecting the presence of the transit vehicles,

10 wherein said controller means is responsive to said transit vehicle detection means for controlling the transmission of the notification signals when the transit vehicle is detected.

15 6. The commuter notification system according to claim 1, wherein said notification receiving means comprises:

a receiver for receiving the transmitted notification signals including the predetermined destination ID identifying the predetermined transit destination;

20 means for decoding the predetermined destination ID to generate an alert enable signal; and

means for generating a sensible alert for alerting the commuter of the arrival of the transit vehicle at the preselected transit destination.

25

7. The commuter notification system according to claim 6, wherein said means for generating a sensible alert generates a tactile alert.

30 8. The commuter notification system according to claim 6, wherein said means for generating a sensible alert generates a visual alert.

9. The commuter notification system according to claim 6
35 further comprising lockout timer means, responsive to the alert enable signal, for inhibiting the further generation of sensible alerts, once the alert has been generated.

10. The commuter notification system according to claim 6, wherein said notification receiving means further comprises:

5 memory means for storing a table of predetermined transit destinations and the corresponding destination IDs identifying the predetermined transit destinations; and
means for selecting from said memory means, the destination ID corresponding to the preselected transit
10 destination for which notification is desired.

11. The commuter notification system according to claim 10, wherein said means for selecting comprises one or more switches.

15

12. The commuter notification system according to claim 10, wherein said notification receiving means further comprises:

20 displaying means for displaying information,
wherein said display means is coupled to said selecting means for displaying the transit destination selected from said memory means.

13. The commuter notification system according to claim 25 10, wherein said notification transmitter means is further capable of transmitting reconfiguration information for enabling the reconfiguration of the table of predetermined transit destinations, and wherein said notification receiver means further comprises reconfiguration means,
30 coupled to said receiver and to said memory means, and responsive to the received reconfiguration information, for reconfiguring the table of predetermined transit destinations.

14. The commuter notification system according to claim 13 wherein said notification transmitter means further comprises data terminal means for enabling the selection of one or more predetermined transit destinations which, when transmitted as reconfiguration information, reconfigures the table of predetermined transit destinations, thereby providing selection of the destination ID's corresponding to the preselected transit destinations for which notification is desired.

10

15. A notification receiver for use in a commuter notification system which provides a plurality of predetermined transit destinations and one or more transit vehicles for carrying commuters between the predetermined transit destinations, and a transmitter, located in proximity to the predetermined transit destinations, for transmitting notification signals including a predetermined destination ID identifying the transit destinations, said notification receiver comprising:
- 5
- 10 a receiver for receiving the transmitted notification signals including the predetermined destination ID identifying the predetermined transit destination;
- means for decoding the predetermined destination ID to generate an alert enable signal; and
- 15 means for generating a sensible alert for alerting the commuter of the arrival of the transit vehicle at the preselected transit destination.
16. The notification receiver according to claim 15, wherein said means for generating a sensible alert generates a tactile alert.
17. The notification receiver according to claim 16, wherein said means for generating a sensible alert generates a visual alert.
- 25
18. The notification receiver according to claim 15 further comprising lockout timer means, responsive to the alert enable signal, for inhibiting the further generation of sensible alerts, once the alert has been generated.
- 30

19. The notification receiver according to claim 15,
wherein said notification receiving means further
comprises:

memory means for storing a table of predetermined
5 transit destinations and the corresponding destination IDs
identifying the predetermined transit destinations; and
means for selecting from said memory means, the
destination ID corresponding to the preselected transit
destination for which notification is desired.

10

20. The notification receiver according to claim 19,
wherein said means for selecting comprises one or more
switches.

15 21. The notification receiver according to claim 19,
wherein said notification receiving means further
comprises:

display means for displaying information,
wherein said display means is coupled to said
20 selecting means for displaying the transit destination
selected from said memory means.

22. The notification receiver according to claim 19,
wherein said notification transmitter means is further
25 capable of transmitting reconfiguration information for
enabling the reconfiguration of the table of predetermined
transit destinations, and wherein said notification
receiver means further comprises reconfiguration means,
coupled to said receiver and to said memory means, and
30 responsive to the received reconfiguration information, for
reconfiguring the table of predetermined transit
destinations.

23. The notification receiver according to claim 15,
35 wherein said means for decoding comprises a microcomputer.

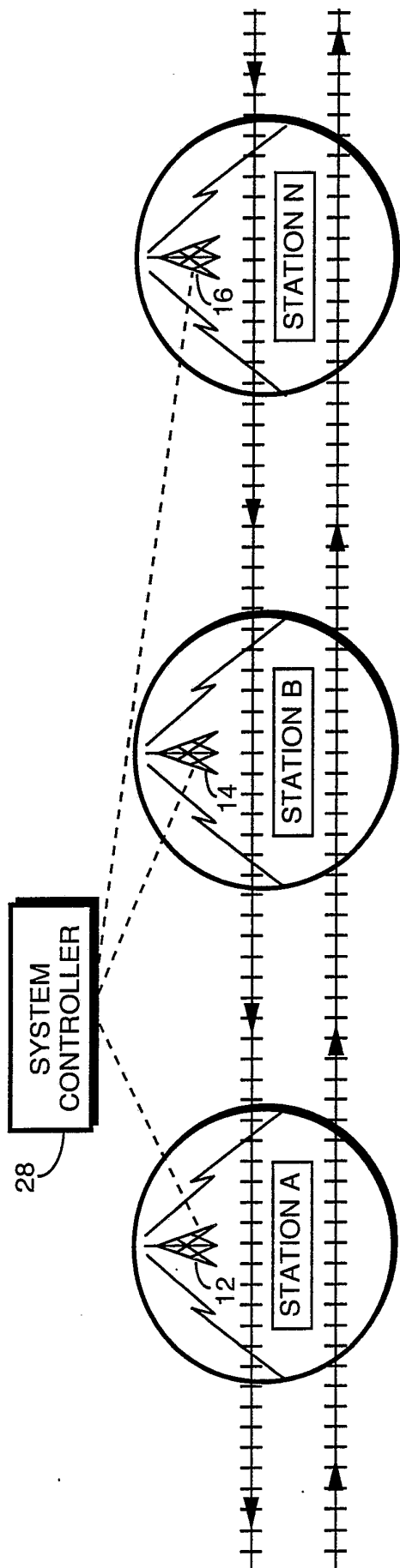

FIG. 1

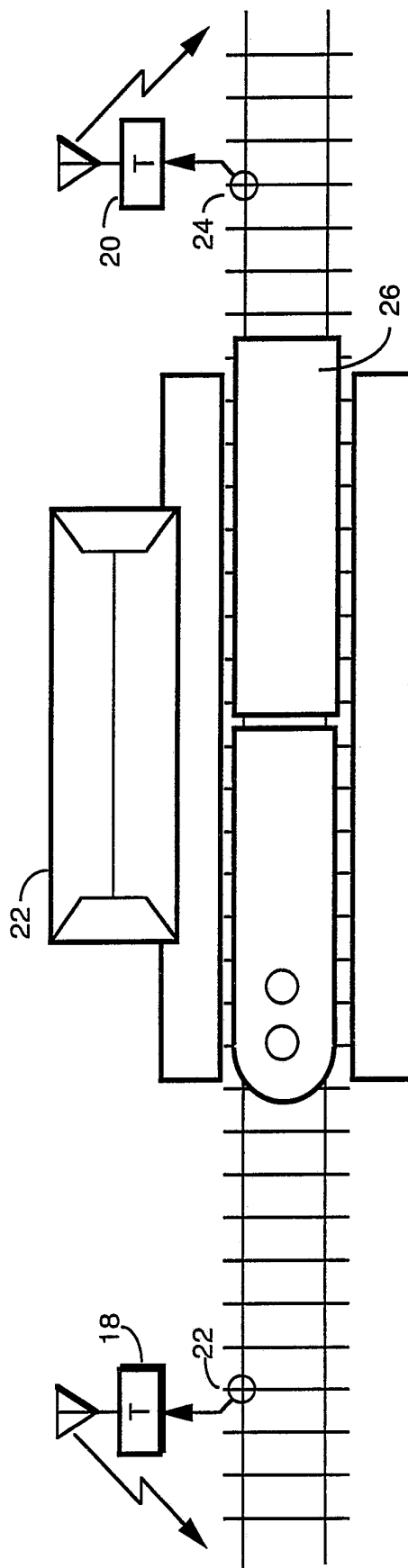

FIG. 2

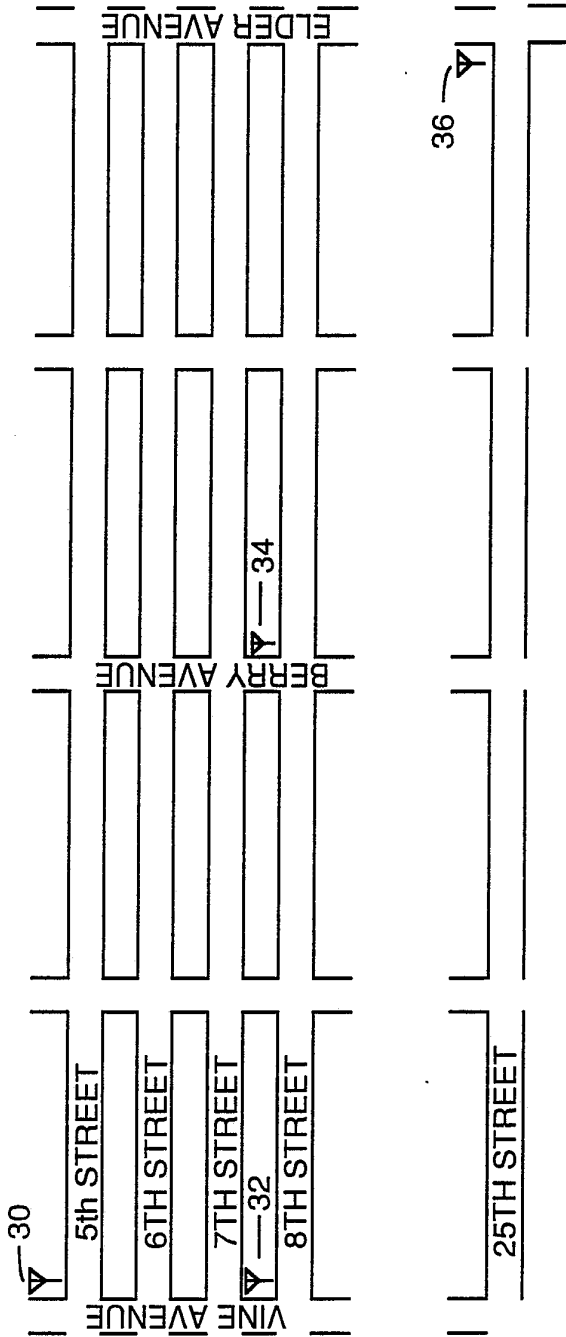

FIG. 3

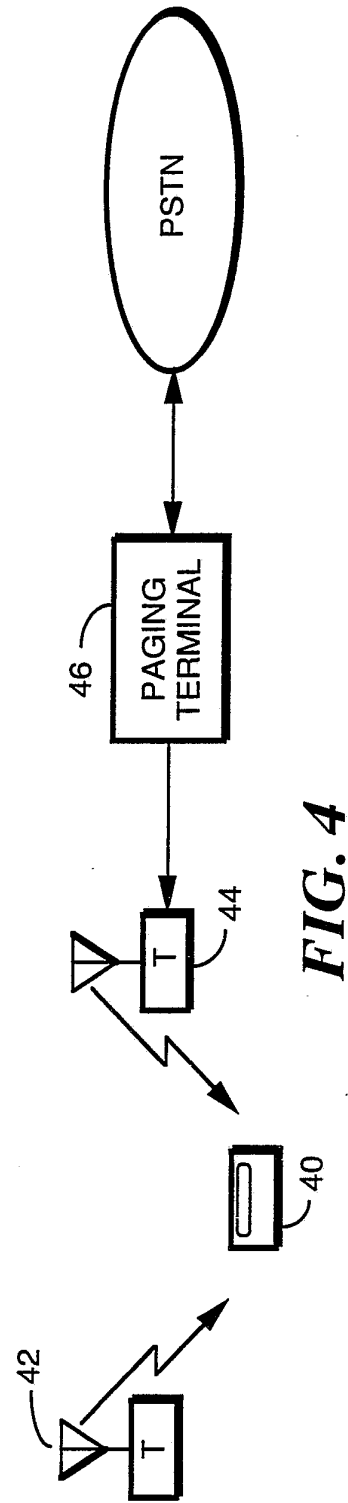

FIG. 4

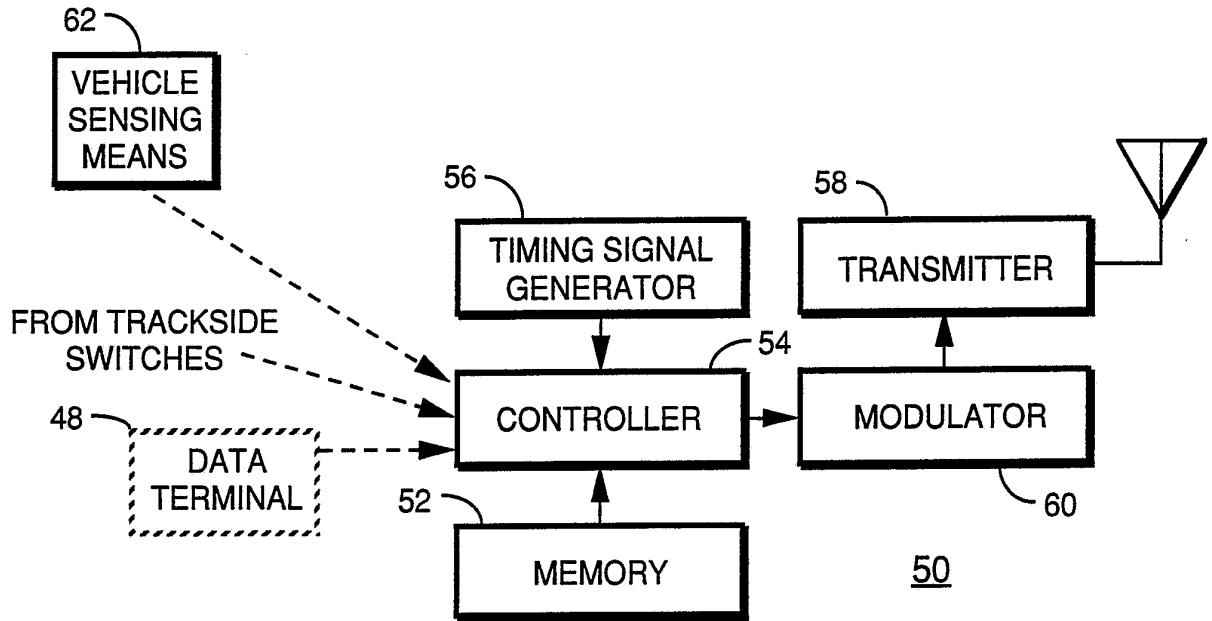

FIG. 5

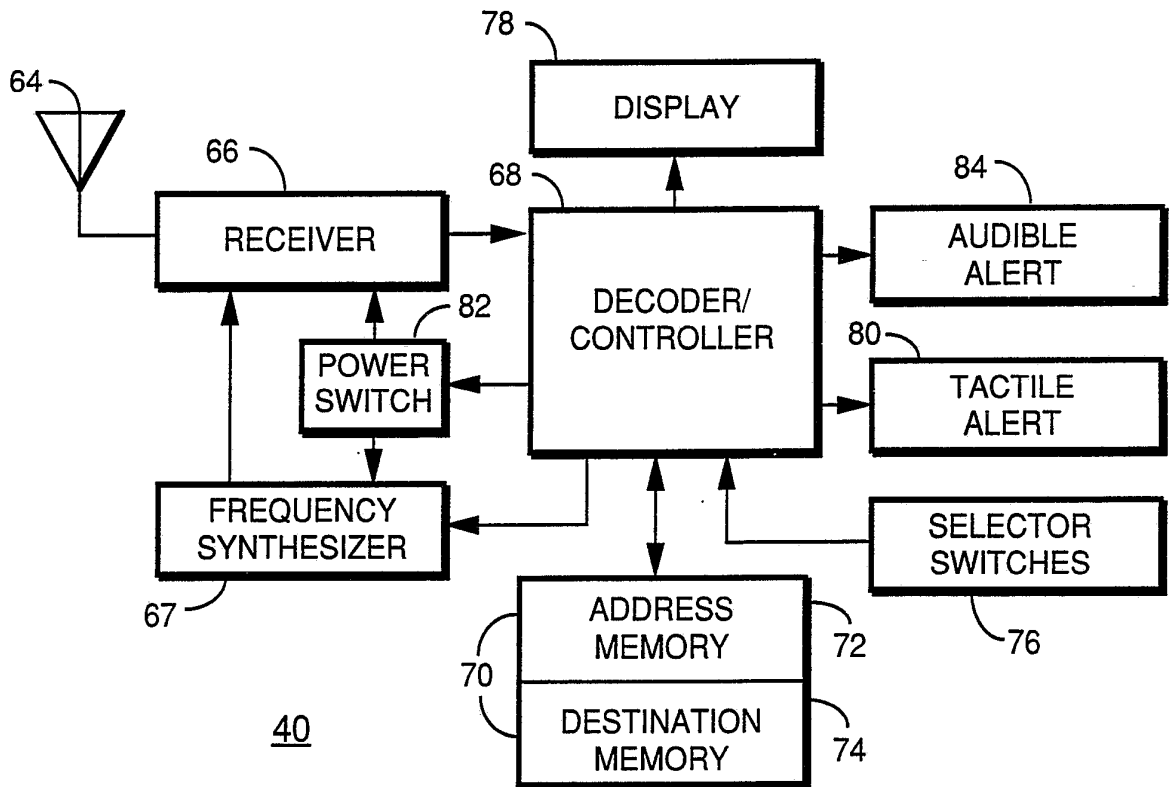

FIG. 6

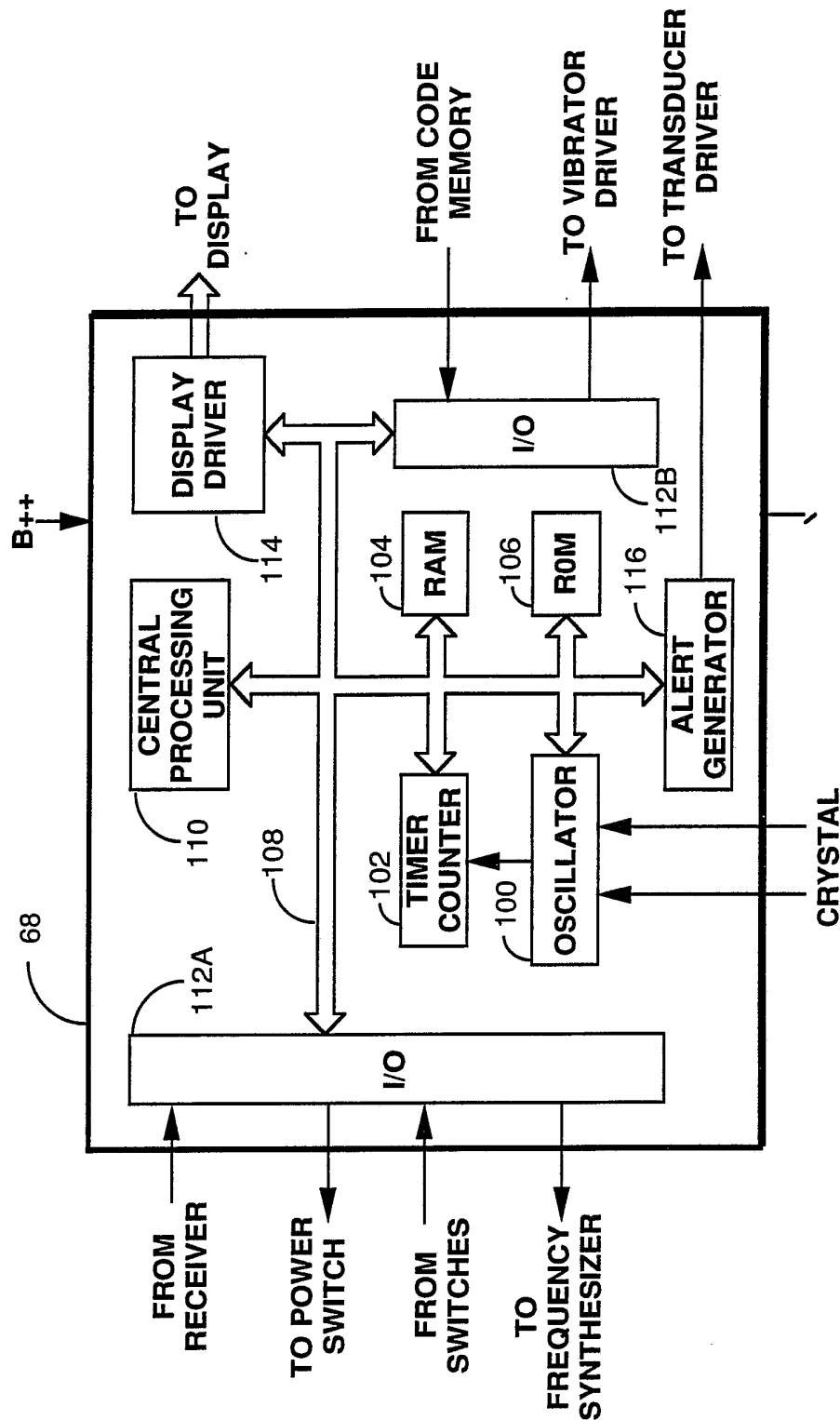

FIG. 7

5/10

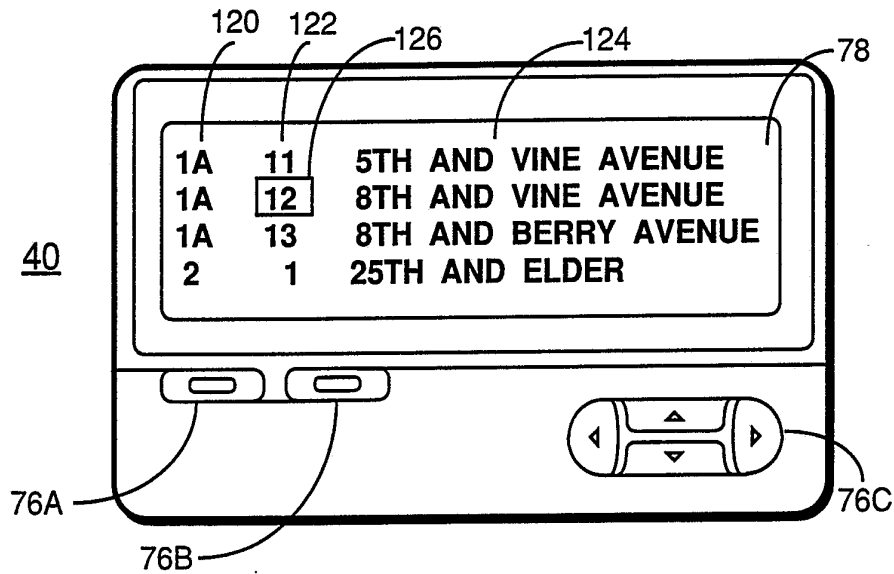

FIG. 8

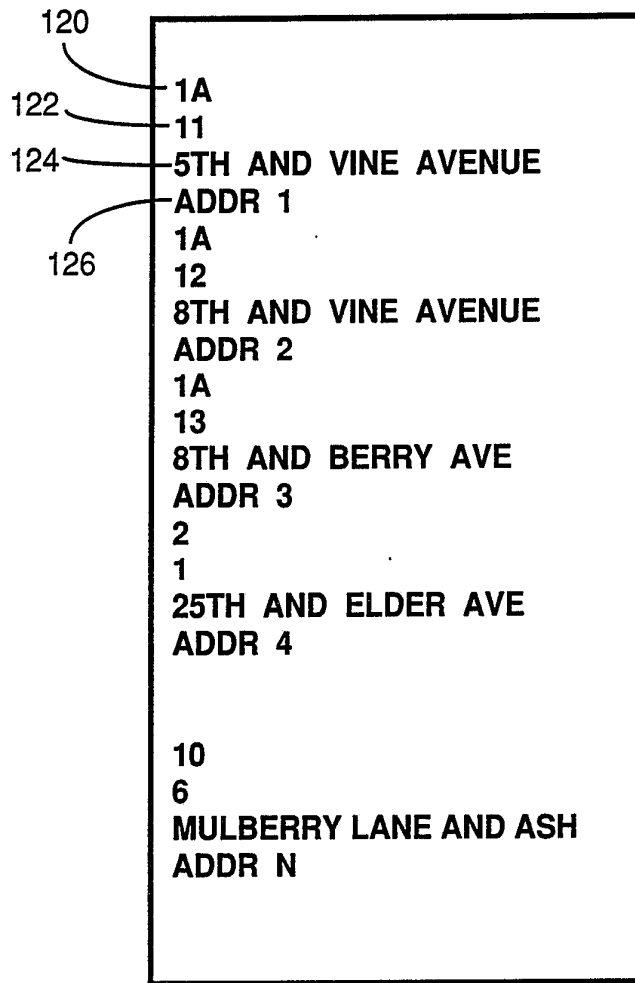

FIG. 9

6/10

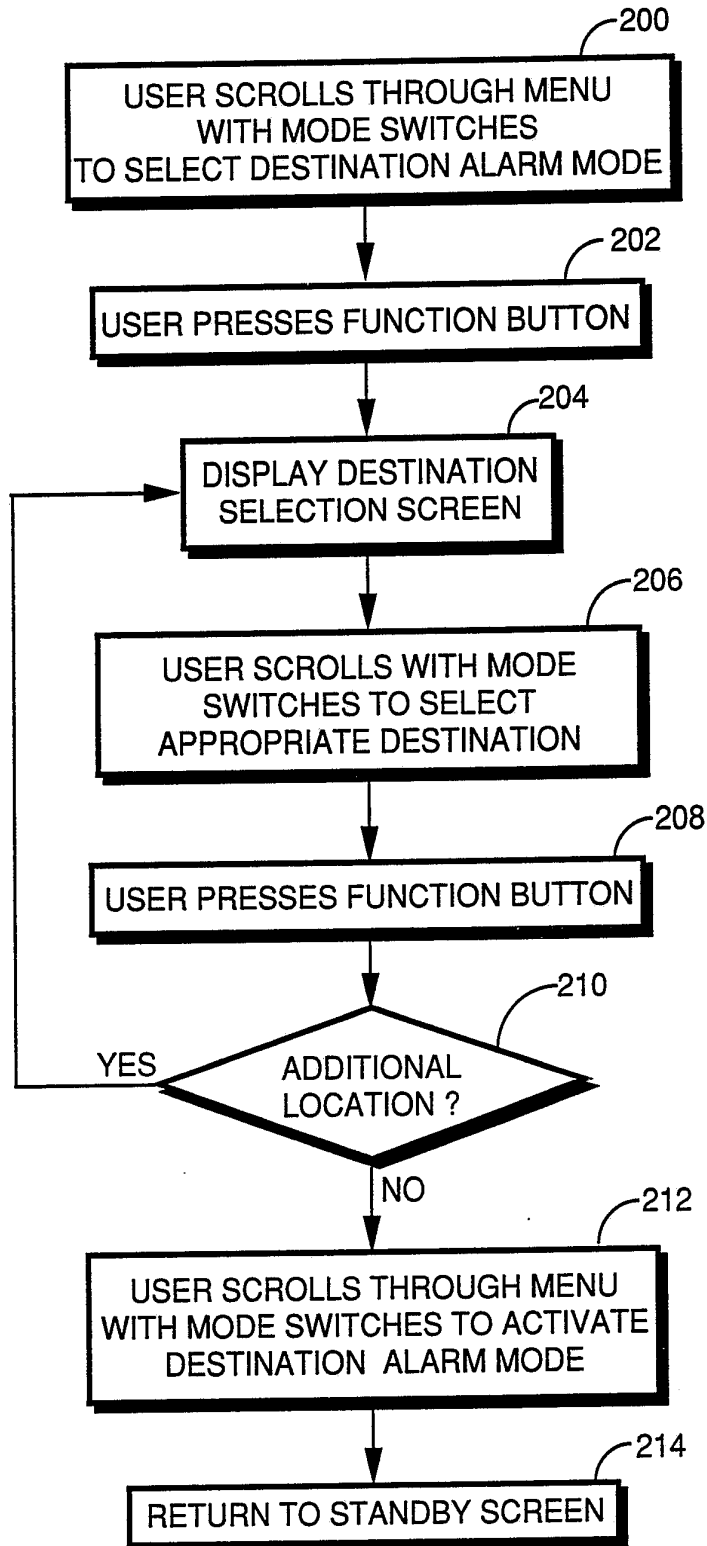

FIG. 10

7/10

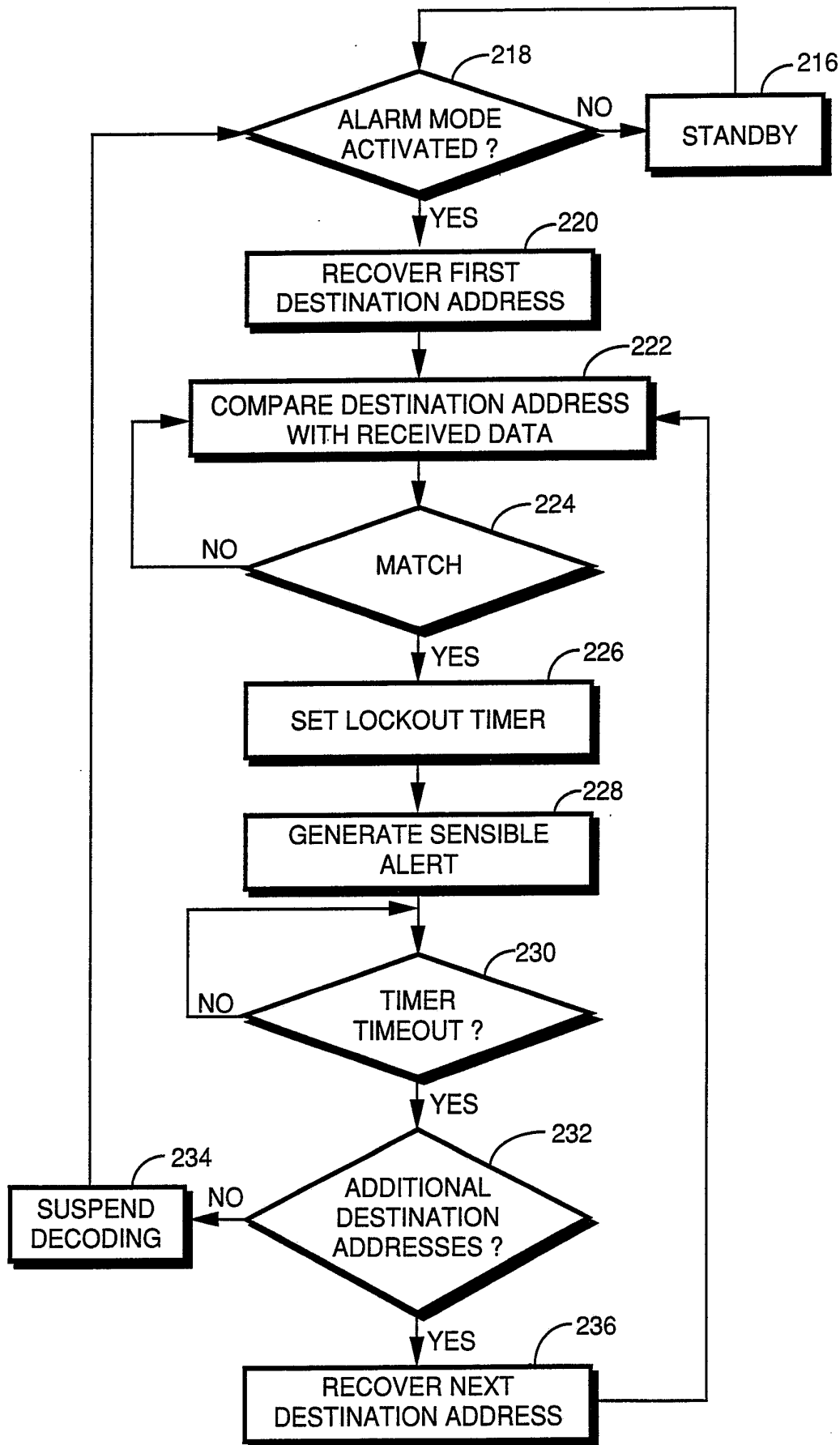

FIG. 11

8/10

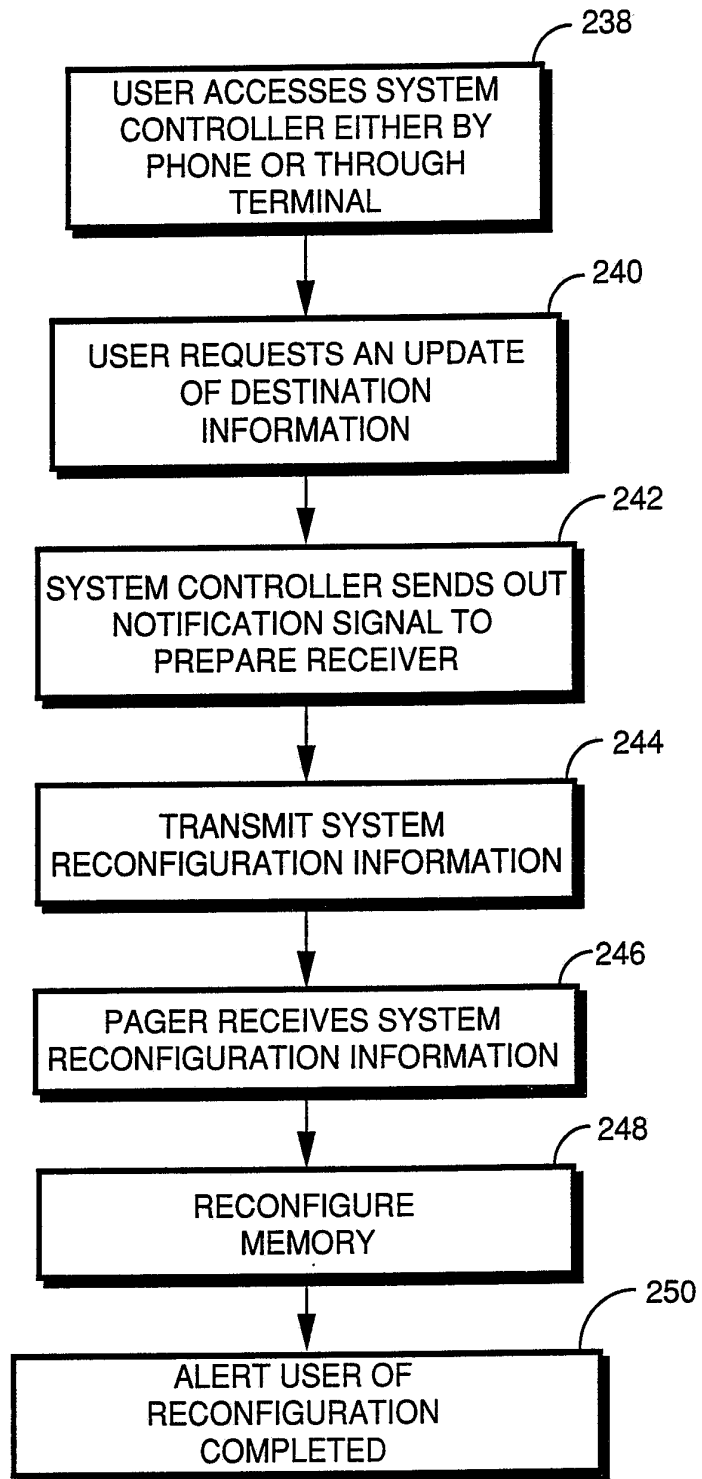

FIG. 12

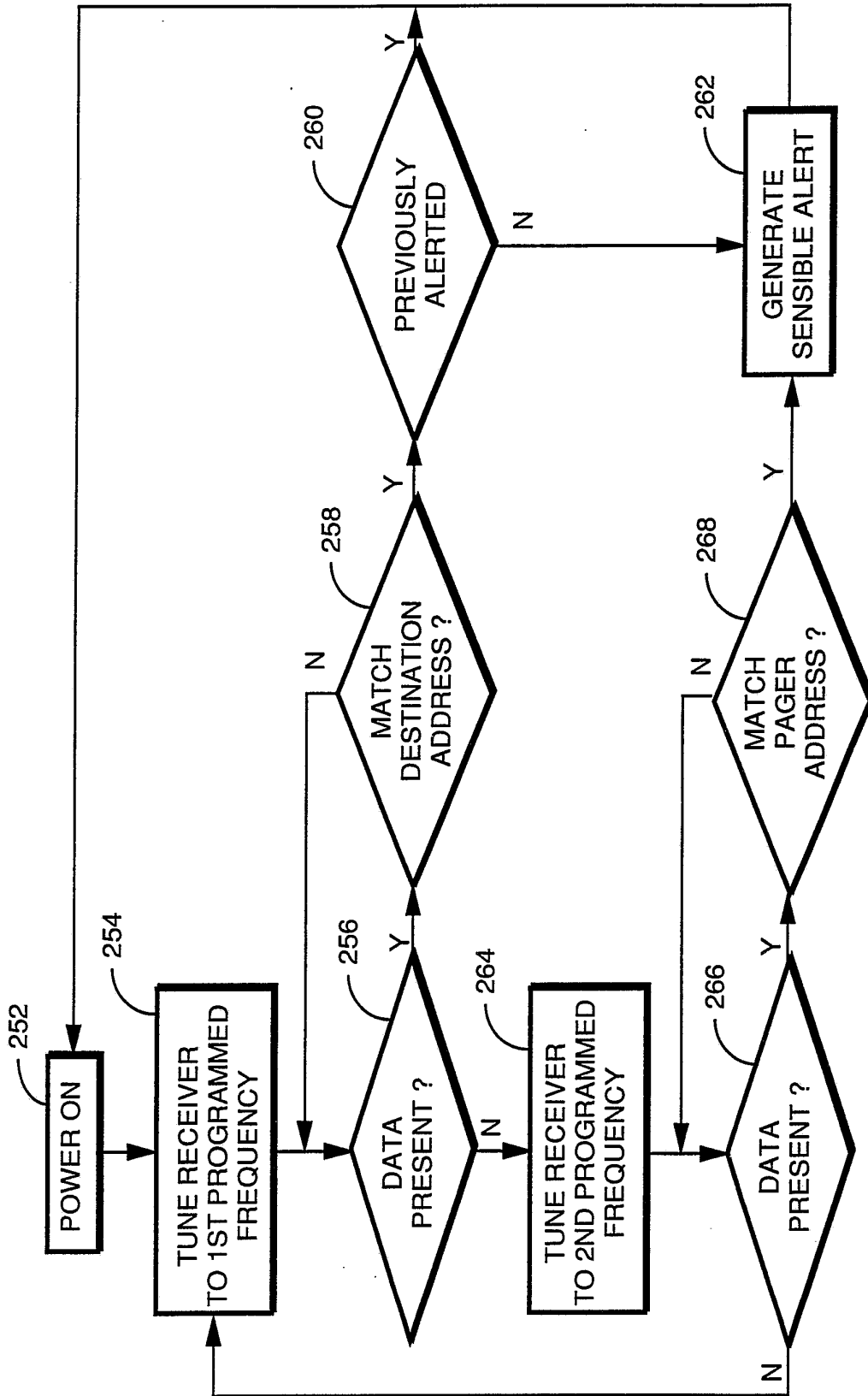

FIG. 13

10/10

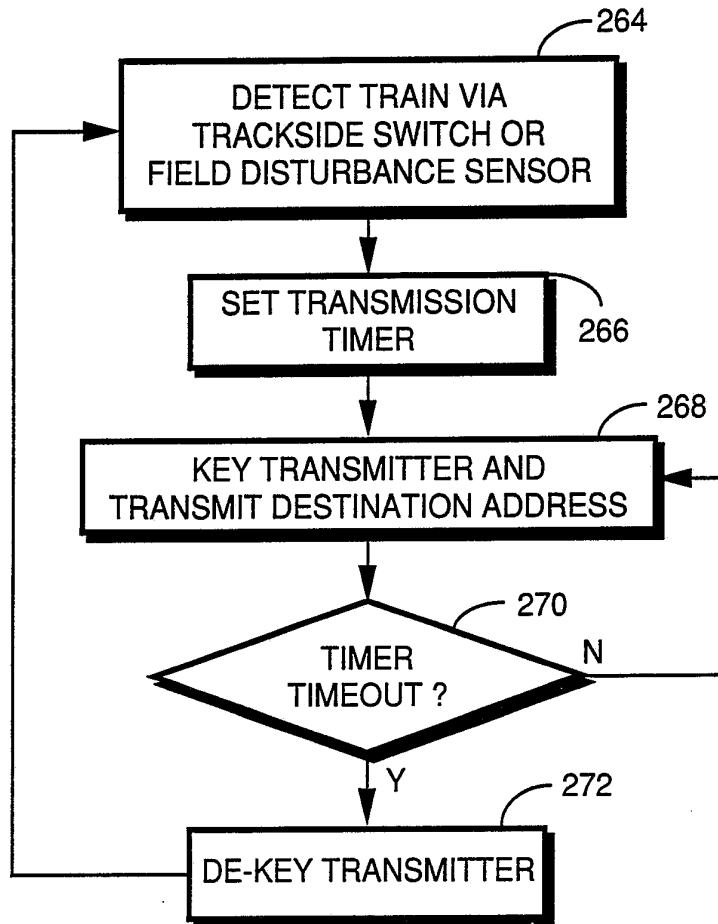

FIG. 14

INTERNATIONAL SEARCH REPORT

PCT/US92/07394

A. CLASSIFICATION OF SUBJECT MATTER

IPC(5) : G08B 5/22; G08G 1/123; H04Q 7/00,9/00
 US CL : 340/825.44,994; 340/825.49,455/33.1

According to International Patent Classification (IPC) or to both national classification and IPC

B. FIELDS SEARCHED

Minimum documentation searched (classification system followed by classification symbols)

U.S. : 340/825.47,825.54,825.55,996; 342/24

Documentation searched other than minimum documentation to the extent that such documents are included in the fields searched

Electronic data base consulted during the international search (name of data base and, where practicable, search terms used)

MAP, SCHEDULE? CINNYT?, TRANSIT, and ROUTE (PTO APS)

C. DOCUMENTS CONSIDERED TO BE RELEVANT

Category*	Citation of document, with indication, where appropriate, of the relevant passages	Relevant to claim No.
Y,P	US, A, 5,087,905 (KURAMATSA ET AL.) 11 February 1992, See Figs. 7A, 7B and 7C; col. 5, lines 39-64.	1-23
X Y	US, A, 5,021,780 (FABIANO ET AL.) 04 June 1991, See entire document.	1-4,6,8, <u>15,17,23</u> 1-23
Y	US, A, 5,012,234 (DULANEY ET AL.) 30 April 1991, See Figs. 4-7.	13,14,22
Y	US, A, 4,857,925 (BRUBAKER) 15 August 1989, See Figs. 6A and 6B.	10,11,13,14, 19,20,22
Y	JP, A, 52-11810 (KATO) 29 January 1977, See abstract (English translation) and Fig. 1.	5

Further documents are listed in the continuation of Box C. See patent family annex.

* Special categories of cited documents:	"T" later document published after the international filing date or priority date and not in conflict with the application but cited to understand the principle or theory underlying the invention
"A" document defining the general state of the art which is not considered to be part of particular relevance	"X" document of particular relevance; the claimed invention cannot be considered novel or cannot be considered to involve an inventive step when the document is taken alone
"E" earlier document published on or after the international filing date	"Y" document of particular relevance; the claimed invention cannot be considered to involve an inventive step when the document is combined with one or more other such documents, such combination being obvious to a person skilled in the art
"L" document which may throw doubts on priority claim(s) or which is cited to establish the publication date of another citation or other special reason (as specified)	"&" document member of the same patent family
"O" document referring to an oral disclosure, use, exhibition or other means	
"P" document published prior to the international filing date but later than the priority date claimed	

Date of the actual completion of the international search 10 DECEMBER 1992	Date of mailing of the international search report 05 JAN 1993
Name and mailing address of the ISA/ Commissioner of Patents and Trademarks Box PCT Washington, D.C. 20231 Facsimile No. NOT APPLICABLE	Authorized officer <i>Andrew Hill</i> ANDREW M. HILL Telephone No. (703) 305-4822

INTERNATIONAL SEARCH REPORT

International application No.
PCT/US92/07394

C (Continuation). DOCUMENTS CONSIDERED TO BE RELEVANT		
Category*	Citation of document, with indication, where appropriate, of the relevant passages	Relevant to claim No.
A	SU, A, 1140256 (LENGD UNDERGROUND) 15 February 1985, See abstract (English translation) and Fig. 1.	1-23
A	GB, A, 2191620 (FURUNO ET AL.) 16 December 1987, See abstract and Fig. 2.	1-23
A	FR, A, 2,648,602 (BALOUTCH) 21 December 1990, See abstract (English translation) and Fig. 1.	1-23
A	JP, A, 3-104427 (TATSUOKA) 01 May 1991, See abstract (English translation) and all Figures.	1-23