

July 17, 1934.

J. F. MOODY

1,966,454

WELL EQUIPMENT

Filed Nov. 2, 1925

4 Sheets-Sheet 2

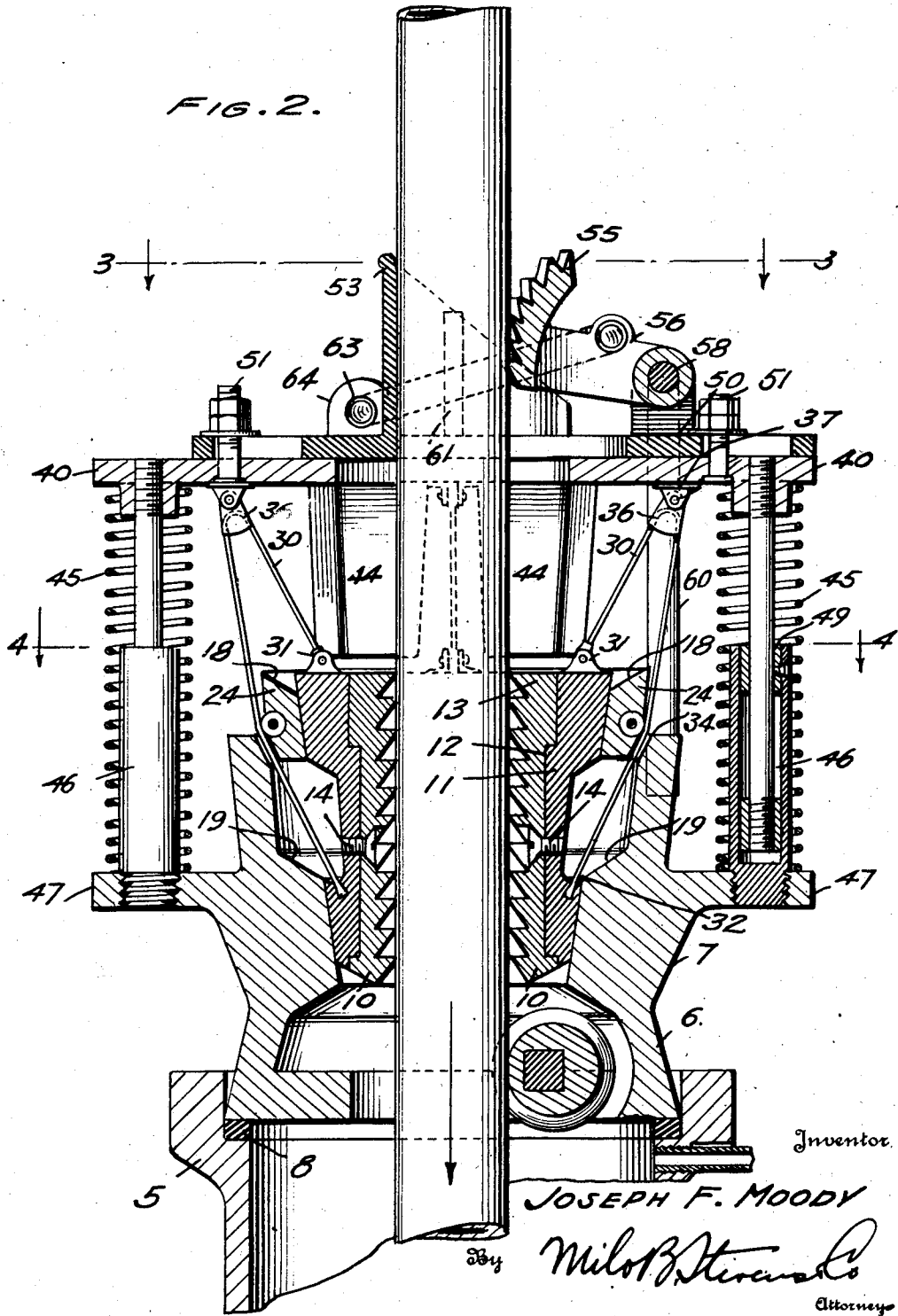

July 17, 1934.

J. F. MOODY

1,966,454

WELL EQUIPMENT

Filed Nov. 2, 1925

4 Sheets-Sheet 3

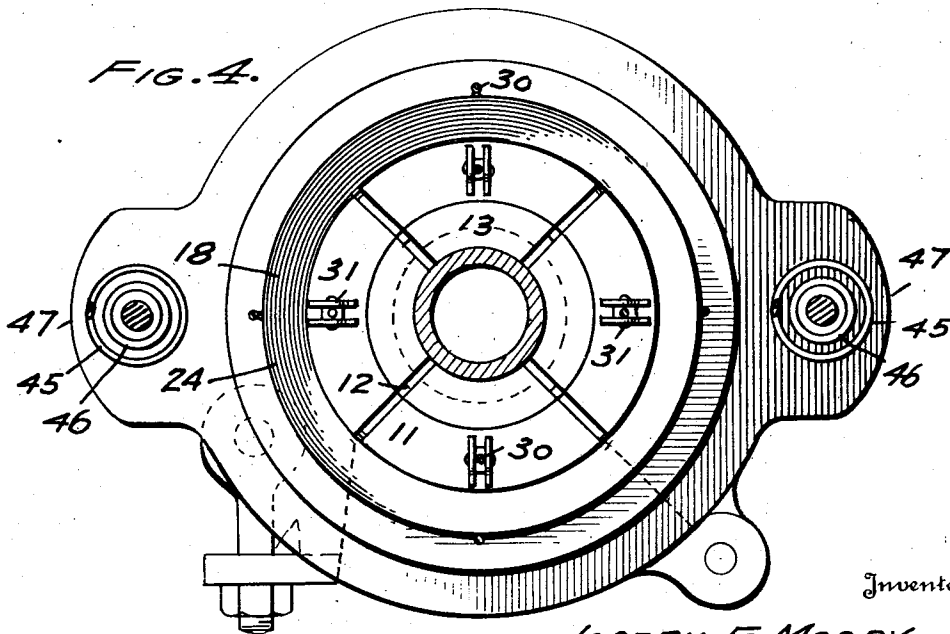
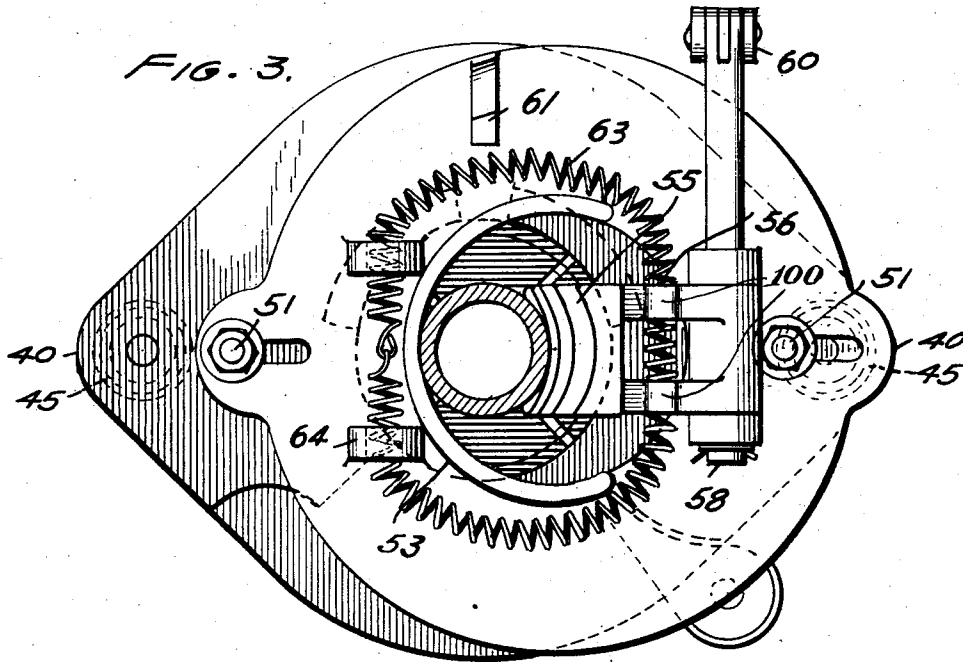

Inventor

JOSEPH F. MOODY

By *Milo B. Stevens*
Attorneys

July 17, 1934.

J. F. MOODY

1,966,454

WELL EQUIPMENT

Filed Nov. 2, 1925

4 Sheets-Sheet 4

FIG. 5.

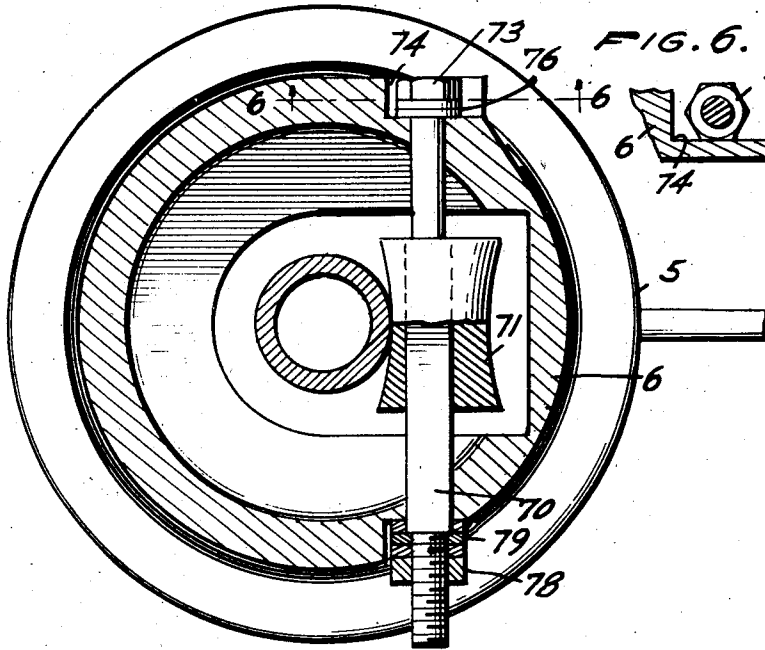

FIG. 6.

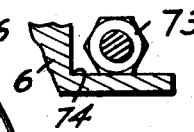

FIG. 8.

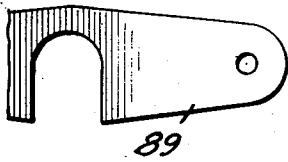

FIG. 7.

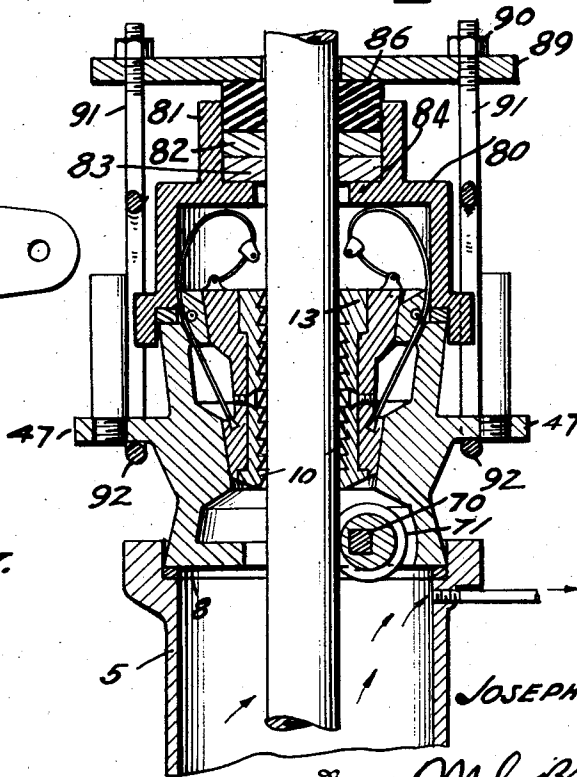
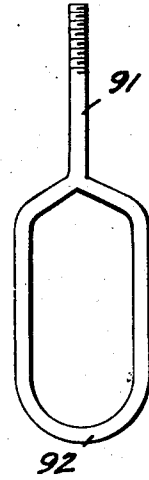

FIG. 9.



Inventor
JOSEPH F. MOODY

By *Milo K. Sturms*
Attorneys

UNITED STATES PATENT OFFICE

1,966,454

WELL EQUIPMENT

Joseph F. Moody, Tulsa, Okla.

Application November 2, 1925, Serial No. 66,421

24 Claims. (Cl. 24-263)

This invention relates to tubing spiders and has for one of its objects the provision of simple means whereby all of the movable slips may be simultaneously dropped into the tubing spider for effective gripping engagement with the tubing to hold the tubing against further descent.

Also, an important aim of the invention is to provide novel means whereby all of the slips may be simultaneously and separately elevated so that the tubing may be either raised or lowered.

Another important feature of the invention resides in the provision of means whereby a packer may be attached to the spider cage or body to form in effect an oil saver.

Other objects and advantages will be apparent during the course of the following description.

In the accompanying drawings forming a part of this application and in which like numerals are employed to designate like parts throughout the same,

Figure 1 is a vertical sectional view through the improved spider applied, the slips being in their elevated positions;

Fig. 2 is a vertical sectional view through the improved tubing spider with the slips in their operative positions;

Fig. 3 is a horizontal sectional view taken on line 3-3 of Fig. 2;

Fig. 4 is a horizontal sectional view taken on line 4-4 of Fig. 2;

Fig. 5 is a horizontal sectional view taken on line 5-5 of Fig. 1;

Fig. 6 is a detail sectional view taken on line 6-6 of Fig. 5;

Fig. 7 is a vertical sectional view through the improved spider equipped with the packer;

Fig. 8 is a perspective of a cross-head embodied in the invention;

Fig. 9 is a side elevation of a connecting bolt embodied in the invention.

In the drawings, wherein for the purpose of illustration is shown a preferred embodiment of the invention, the numeral 5 designates a casing or casing head into which the tubular attaching portion 6 of the improved spider ring or body 7 is extended. As illustrated in Fig. 1, a gasket 8 may be positioned between the lower end of the attaching portion 6 and the supporting shoulder within the upper portion of the member 5 to provide a substantially gas and oil tight connection.

The body 7 is provided with a tapered opening for the reception of a suitable number of similarly formed slips 10, the inner faces of which are formed with protuberances 11, these pro-

tuberances being received in elongated sockets 12 in the opposed faces of wear members 13. Fig. 1 clearly illustrates that the wear members are held in place by screw bolts 14 or other suitable fastening devices. When the tooth carrying wear plates 13 become worn it is a simple matter to renew the same. Also, if a slip of a larger or smaller size is desired this may be provided for by the substitution of a larger or smaller wear member 13. The arrangement illustrated provides for an extremely hard wear resisting plate or member 13, while the slips 10 may be of somewhat softer material.

In carrying out the invention the tapered wall of the body 7 is provided with inclined shoulders 18 and 19 which are engaged by shoulders of the same inclination on the outer faces of the slips 10. Thus when the slips are moved downwardly they are moved inwardly into firm gripping engagement with the tubing.

The shoulders 18, clearly shown in Figs. 1 and 2, are located at the upper ends of extensions 24 of the body 7, which extensions provide bearing surfaces of generous areas for the slips 10 whereby the slips are firmly held in engagement with the tubing. Particular attention is directed to the fact that the extensions 24 are partly received in sockets 26 in the outer faces of the slips and this arrangement causes the slips to move inwardly and outwardly substantial distances when the same are moved lengthwise.

In carrying out the invention, the slips have connection with the ends of flexible members or cables 30, one end of each cable being connected to the upper end of one of the slips as shown at 31 and the other end of the cable being connected to the outer portion of the slip as shown at 32. The upper portion of the body 7 is provided with a plurality of openings or channels 34 for the passage and guidance of the lower portion of the cable 30. Fig. 1 plainly illustrates that a fastener 36 is connected to each cable 30 between the ends thereof and is detachably connected to a hanger 37 by a pin 38 or other quickly detachable connecting device. The hangers 37 are permanently connected to the under side of the head 40 of the spider and when it is desired to detach the head for a purpose to be fully hereinafter specified it is merely necessary to first detach the pins 38 whereupon the cables 30 will drop loosely to the positions illustrated in Fig. 7. Fig. 1 illustrates that the head 40 is provided with depending striking elements 44 which engage and assure the uniform descent of the slips into the

tapered opening. This, however, takes place only when the head is drawn down by the descent of the slips.

The head 40 is normally held in an elevated position by a plurality of springs 45 which surround telescoping members 46, the outer sections of the telescoping members 46 being anchored to radial lugs 47 of the body 7 while the inner sections of the telescoping members are anchored to the head 40. Suitable stops are incorporated in the telescoping members 46 and limit the extension of the same. However, the stops may be quickly disconnected to permit of the disconnection of the head 40.

The latching or hook-on device is in the nature of a base plate 50 secured to the head 40 by fastening bolts or other fastening devices 51. The base plate 50 is provided with an opening for the reception of the tubing and this opening is surrounded by an upwardly directed arcuate flange 53, the intermediate portion of the arcuate flange being substantially higher than the ends thereof. With reference to Figs. 1, 2 and 3 it will be observed that a toothed dog 55 is mounted on an arm 56 and is adapted to be swung into engagement with the tubing so as to lock the tubing to the base plate 50. Fig. 3 plainly illustrates that the arm 56 is mounted upon a shaft 58, the end of which has a hand controlled lever 60 pivoted thereto. When the lever 60 is resting on a supporting bracket 61 the dog 55 is held in an elevated position. However, when the lever 60 is released from engagement with the bracket 61 a coil spring 63 engaged with the arm 56 is free to swing the dog 55 into engagement with the tubing. Fig. 3 clearly shows that the coil spring 63 is extended through the intermediate portion of the arm 56 and through upstanding ears 64 behind the intermediate portion of the flange 53 and beneath the arched humps 75 in the arm 56.

It will be seen that when it is desired to cause the descent of the slips 10 into the tapered body it is merely necessary to release the dog 55 so that the same will be engaged by the rapidly descending tubing. This, of course, exerts a substantial downward pressure on the head 40 and the slips are immediately caused to descend into the tapered body and clutch onto the tubing.

Referring now to Figs. 1, 5 and 6, it will be seen that a shaft 70 is extended through the attaching portion 6 and carries an eccentrically mounted spool-like member 71 for engaging the tubing and straightening the same, the same broad idea being set forth in my Letters Patent No. 1,548,543, dated August 4, 1925. It will be seen that the tubing contact member 71 has a squared bore which snugly receives the squared shaft 70. The head 73 of the shaft 70 is flatly engaged with the bottom wall of a niche 74 in the attaching portion 6 so as to hold the shaft against accidental turning. Suitable washers 76 may be interposed between the head 73 and the inner wall of the niche 74 to prevent leaks, etc.

The opposite end of the shaft 70 is threaded and is provided with a nut 78 to lock the shaft in place and to bind the washers 79 firmly in position to prevent the escape of either gas or oil. The nut 78 provides a means whereby the eccentrically mounted tubing contact member may be locked in the desired position for overcoming the tendency of the tubing to occupy an inclined position. The eccentrically mounted

member 71 may be turned from time to time as the occasion requires to compensate for wear.

Subsequent to the descent of the slips 10, the head 40 and the clutching-on mechanism including the dog 55 may be completely removed and a packing cap 80 and associated elements substituted therefor. As previously stated, the cables 30 may be quickly removed from the head 40 when it is desired to detach the head 40 and associated mechanism. The cap 80 is provided with an upwardly directed annular shoulder 81 within which a packing unit 82 is placed. A suitable metal sectional washer 83 may rest upon an internal annular shoulder 84 at the upper portion of the cap and will, of course, support the gasket or packing unit 82. A second sectional washer 86 may be pressed into engagement with the gasket 82 by a pressure plate 89, which pressure plate may be drawn downwardly by the nuts 90 on bolts 91. The lower portions of the bolts 91 have loops 92 which extend about the ears 47. The running down of the nuts 90 on the bolts 91 will result in clamping the packing 82 tightly in engagement with the tubing and the annular flange 81 so as to prevent leakage of gas or oil. Therefore, in case the rigging is blown or burned down leakage of the oil as a result of the bending of the tubing will not take place.

In the operation of the improved apparatus the body is mounted on the casing as shown in Figs. 1 and 2 and when it is desired to stop the descent of the tubing by engagement of the slips therewith the handle or lever 60 is moved upwardly and outwardly so as to clear the bracket upon which it rests. The spring 63 will now swing the dog 55 into engagement with the tubing regardless of the diameter of the tubing and the base plate 50 will be forced downwardly with the head 40 so that the slips will either drop down or be driven down into the tapered body 7 by the striking element 44. As previously stated, the descent of the slips will bring the tubing to a halt and if desired the head 40 may be removed together with the clutching-on mechanism and the packing illustrated in Fig. 7 substituted to provide a substantially fluid tight arrangement.

Having thus described the invention, what is claimed is:

1. A tubing gripping apparatus of the character specified comprising a body having a tapered bore and extensions at the upper portion of the body, and slips received in said bore and having sockets to receive said extensions whereby to permit of the extensive radial movement of the slips, the upper ends of said extensions and the adjacent walls of said sockets being inclined to support and guide said slips in the radial movement thereof.

2. A spider ring comprising a body having a tapered bore and extensions at the upper portion of the body, and slips received in said bore and having sockets adapted to receive said extensions whereby to permit of the substantial radial movement of the slips, the lower ends of said slips and the intermediate portion of the wall of said tapered bore being similarly inclined to support and guide said slips in the radial movement thereof.

3. A tubing gripping apparatus comprising a body, slips associated with the body, cables having their ends connected to the slips, fasteners connected to the intermediate portions of the cables, a head having hangers, pins connecting the hangers to the fasteners, and means asso-

ciated with the head to clutch onto a tubing whereby to cause the head to descend.

4. A tubing gripping apparatus comprising a body, slips associated with the body, cables having their ends connected to the slips, fasteners connected to the intermediate portions of the cables, a head having hangers, pins connecting the hangers to the fasteners, means associated with the head to clutch onto a tubing whereby to cause the head to descend, and depending striking elements carried by said head and adapted to force said slips into said body.

5. A tubing gripping apparatus comprising a body, slips associated with the body, cables having their ends connected to the slips, fasteners connected to the intermediate portions of the cables, a head having hangers, pins connecting the hangers to the fasteners, means associated with the head to clutch onto a tubing whereby to cause the head to descend, depending striking elements carried by said head and adapted to force said slips into said body, and a plurality of separate springs normally holding said head and said slips in elevated positions.

6. In a tubing gripping mechanism, a plate, a shaft carried thereby, an arm connected to the shaft and having a dog adapted to engage a tubing, said plate having tubing contact means opposed to said dog, a spring normally urging the dog into engagement with the tubing, a lever carried by the shaft, and means cooperating with the plate and lever to hold the lever in a fixed position whereby the dog is held in an inoperative position.

7. In a tubing gripping mechanism, a body having a tubing contact flange, a shaft opposite said flange and having an arm extending therefrom, a dog actuated by said arm and adapted to engage the tubing, a lever carried by said shaft, and means cooperating with said body and lever to hold said dog in an inoperative position.

8. In a tubing gripping mechanism, a body having a tubing contact flange, a shaft opposite said flange and having an arm extending therefrom, a dog actuated by said arm and adapted to engage the tubing, an arm pivoted to said shaft, means cooperating with said body and arm to hold said arm in an inoperative position, and spring means constantly urging said dog into engagement with a tubing.

9. A tubing gripping mechanism comprising a body having a tapered bore and extensions at the upper portion of said bore, slips adapted to be received in said bore, there being channels between said extensions and said body, cables connected to the intermediate portions of said slips and extended through said channels, said cables also being connected to the upper portions of said slips, fasteners connected to said cables intermediate the ends thereof, a head above said slips, and means detachably connecting said fasteners to said head whereby the head may be entirely disconnected from the cables.

10. A tubing gripping mechanism comprising a body having a tapered bore and extensions at the upper portion of said bore, slips adapted to be received in said bore, there being channels between said extensions and said body, cables connected to the intermediate portions of said slips and extended through said channels, said cables also being connected to the upper portions of said slips, fasteners connected to said cables intermediate the ends thereof, a head above said slips, means detachably connecting said fasten-

ers to said head whereby the head may be entirely disconnected from the cables, and depending striking elements carried by said head and adapted to engage said slips.

11. In a tubing gripping mechanism, a body adapted for surrounding a tubing and having a work receiving opening for different sized work, a substantially rotatable shaft carried by the body and spaced laterally from the axis thereof immediately adjacent said opening, a tubing contact member non-rotatably mounted on said shaft and disposed eccentrically of the shaft and body whereby to be extended into said opening on rotation of said shaft and different surfaces presented to the tubing, and said shaft and body having interengaging locking portions for locking the shaft against rotation.

12. In a device of the class described, a body, a shaft cooperating with the body, a tubing contact spool-shaped member eccentrically mounted on the shaft, said body and shaft being provided with cooperating means to hold the shaft against turning, and one of said means being adjustable and removable whereby to secure the shaft in an adjusted position.

13. In a device of the class described, a body having an opening for the passage of a tubing, a spool-shaped member arranged within the body and adapted to engage a tubing, means eccentrically supporting the spool-shaped member, and an adjusting device cooperating with said means and the body whereby the spool-shaped member may be adjusted to compensate for wear or to change the position of the tubing.

14. A tubing gripping apparatus comprising a tapered body, slips received in the body, cables having their ends connected to the upper and lower end of said slips, and a head having connection with the intermediate portions of said cables.

15. A tubing gripping apparatus comprising a tapered body, slips received in said body, cables having their ends connected to the upper and lower portions of said slips, a head, and hangers carried by said head and having means for detachably engaging the intermediate portions of said cables.

16. A tubing gripping apparatus of the character specified comprising a body having a tapered bore and extensions at the upper portion of the body, slips received in said bore and having sockets to receive said extensions whereby to permit of the extensive radial movement of the slips, the upper ends of said extensions and the adjacent walls of said sockets being inclined to support and guide said slips in the radial movement thereof, and a pipe centering means carried by said body and located adjacent the outlet of said bore below the ends of the slips.

17. A tubing gripping apparatus of the character specified comprising a body having a tapered bore and extensions at the upper portion of the body, slips received in said bore and having sockets to receive said extensions whereby to permit of the extensive radial movement of the slips, the upper ends of said extensions and the adjacent walls of said sockets being inclined to support and guide said slips in the radial movement thereof and an adjustable wear compensating centering means carried by said body and located adjacent the outlet of said bore below the ends of the slips.

18. A tubing gripping apparatus of the character specified comprising a body having a tapered bore and extensions at the upper portion

80
85
90
95
100
105
110
115
120
125
130
135
140
145
150

of the body, slips received in said bore and having sockets to receive said extensions whereby to permit of the extensive radial movement of the slips, the upper ends of said extensions and the adjacent walls of said sockets being inclined to support and guide said slips in the radial movement thereof, a pipe centering means carried by said body and located adjacent the outlet of said bore below the ends of the slips, and pipe engaging means for actuating said slips.

19. In a tubing gripping mechanism, a body having a tubing contact flange, a shaft opposite said flange and having an arm extending therefrom, a dog actuated by said arm and adapted to engage the tubing, a second arm pivoted to said shaft, means cooperating with said body and said second arm to hold the latter in an inoperative position, and spring means constantly urging said dog into engagement with a tubing.

20. In a tubing gripping mechanism, a body having a fixed tubing contact portion, a shaft opposite said tubing contact portion and having an arm extending therefrom, a dog actuated by said arm and adapted to engage the tubing against said fixed contact portion, operating means for said shaft, and spring means for normally actuating said dog into engagement with the tubing.

21. In a tubing gripping mechanism, a body having a fixed tubing contact portion, a shaft opposite said tubing contact portion and having an arm extending therefrom, a dog actuated by said arm and adapted to engage the tubing against said fixed contact portion, operating means for said shaft, and spring means for normally actuating said dog into engagement with the tubing; said spring means acting through said arm.

22. In a tubing gripping mechanism, a body having a fixed tubing contact portion, a shaft opposite said tubing contact portion and having an arm extending therefrom, a dog on said arm and adapted to engage the tubing against said fixed contact portion, operating means for said shaft, spring means for normally actuating said dog into engagement with the tubing, and locking means for holding said dog out of tubing-engaging position.

23. A gripping device comprising a frame, a pair of jaws mounted in said frame, said jaws being adapted to clamp a member against movement in one direction and being normally out of contact with such member to be clamped, and means normally engaging and positively supporting a pipe member in any position along its length, when the pipe member is moving downwardly, said means, upon downward movement of the pipe member, being operative to move the jaws into engagement with the pipe member.

24. A gripping device comprising a frame, a clamping jaw mounted in said frame, an auxiliary jaw cooperatively related with the clamping jaw and formed to engage and support a member to be clamped at any point throughout the length of such member, and resilient means cooperating with said jaws to normally maintain the auxiliary jaw in constant contact throughout the length of a member to be clamped and the clamping jaw out of contact with such member.

JOSEPH F. MOODY.

40 115

45 120

50 125

55 130

60 135

65 140

70 145

75 150