

Jan. 26, 1937.

V. R. REED

2,068,708

FUSE FOR PROJECTILES

Filed June 14, 1935

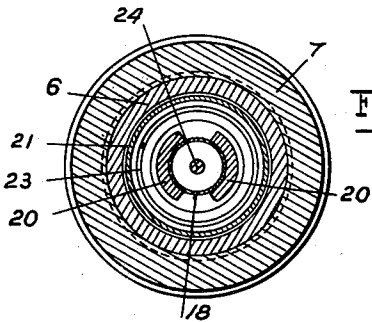
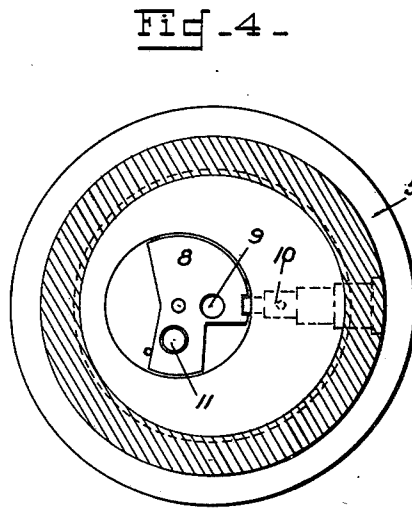
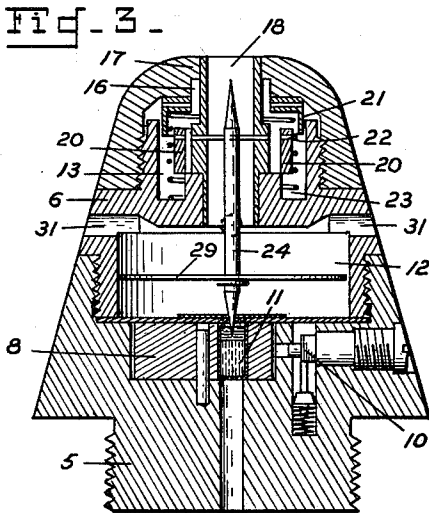
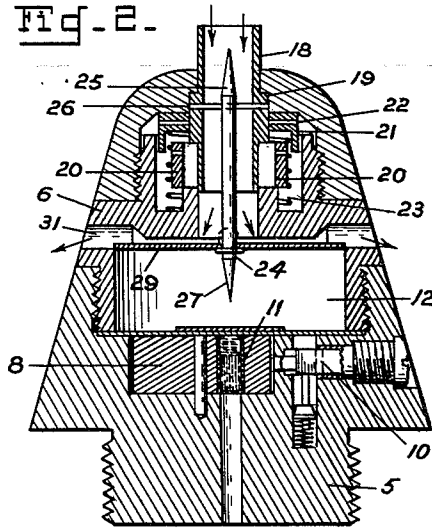
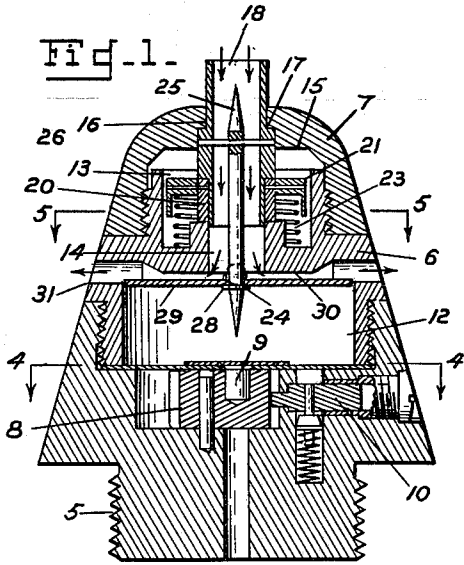

Inventor
Virgil R. Reed
By W. N. Roach
Attorney

UNITED STATES PATENT OFFICE

2,068,708

FUSE FOR PROJECTILES

Virgil R. Reed, Dover, N. J.

Application June 14, 1935, Serial No. 26,623

5 Claims. (Cl. 102—39)

(Granted under the act of March 3, 1883, as amended April 30, 1928; 370 O. G. 757)

The invention described herein may be manufactured and used by or for the Government for governmental purposes, without the payment to me of any royalty thereon.

This invention relates to a fuse for projectiles. In supersensitive point-detonating fuses of the air-balanceable type it is customary to direct the intrushing air to the rear of the striker in order to establish a dominating internal pressure which will maintain the striker in the forward position during flight. The unbalanced relation between the pressures on the front and on the rear faces of the striker is upset when the striker encounters an obstacle such as the fabric of an aircraft and the striker is driven rearwardly to function the fuse.

The purpose of this invention is to provide a fuse in which this same relation of unbalanced pressures on the sides of the striker is obtained by directing the air-stream on the front side of the striker. The principle of operation is based on the theorem that a stream of air, when forced through an opening and exhausted over a flat surface, will reduce the pressure on that surface below atmospheric pressure.

To these and other ends, the invention consists in the construction, arrangement and combination of elements described hereinafter and pointed out in the claims forming a part of this specification.

A practical embodiment of the invention is illustrated in the accompanying drawing, wherein:

Fig. 1 is a longitudinal sectional view of the improved fuse showing the parts in the safe or unarmed position.

Fig. 2 is a similar view with the parts in the armed position during flight.

Fig. 3 is a similar view with the parts in the fired position.

Figs. 4 and 5 are sectional views on the corresponding lines of Fig. 1.

The fuse comprises a casing formed of a base 5, a body 6 threaded to the base, and a cap or nose 7 threaded to the body. The base carries a conventional rotor 8 having a blind cavity 9 which is disposed on the axis of the fuse when the rotor is held in the safe position by the centrifugally releasable bolt 10 and also having a primer detonator 11 which is moved into position axially of the fuse when the released rotor swings on its pivot under the influence of centrifugal force.

The body 6 has a chamber or cavity 12 in its rear part, a chamber or cavity 13 in its front part, and a central passage 14. The nose 7 which

has its inner face 15 spaced from the front end of the body when assembled thereto is also provided with a central passage 16 which is counter-bored to provide an annular shoulder 17.

A striker includes a tube 18 having its front part extruded from the nose in both the unarmed and armed position and its rear part disposed in the central passage 14 of the body. The tube is formed with a collar 19 and is held immovable when the collar is confined between the shoulder 17 of the nose and ring segments 20—20 which are seated on the body.

The segments are normally held against the tube and in rear of the collar by means of a sleeve 21 which is disposed in the front cavity 13 of the body and which is connected to each of the segments by the shear pin 22—22. The opening in the sleeve is greater than the diameter of the collar. A helical spring 23 is interposed between the sleeve 21 and the body 6.

The tube 18 carries a firing pin 24 which is arranged in the center of the tube and spaced from its walls and has a pointed front end 25 so as to interfere as little as possible with the air-stream that passes through the tube at high velocity when the projectile is in flight. The firing pin is secured to the tube by a pin 26. The pointed rear end 27 of the firing pin is disposed in the rear cavity 13 of the body and is adapted to set off the primer 11.

A collar 28 is provided on the firing pin directly in front of the pointed rear end 27 and serves to carry a disc 29 which has a loose sliding fit in the rear cavity 12. When the striker is in the forward extruded position the disc 29 is spaced a small distance from the front wall 30 of the cavity. The body 6 is provided with a plurality of radial ports 31 leading from the front end of the cavity 12 to atmosphere.

The parts of the fuse are normally in the safe or unarmed position as shown in Fig. 1. When the projectile equipped with the fuse is fired from a gun the sleeve 19 sets back, shearing the pins 22 and compressing the spring 23. During set-back the sleeve 21 maintains the segments 20 under the collar of the striker. After the projectile has left the bore of the gun the spring 23 assisted by linear deceleration causes the sleeve to move forward against the nose 7 and free the segments 20 which are thrown outwardly by centrifugal force due to rotation of the projectile and clear the collar of the striker. At the same time the rotor 8 is moved to armed position by centrifugal force.

Before the sleeve has reached its forward po-

sition the projectile has traveled a sufficient distance away from the muzzle of the gun to permit air to enter through the front end of the tube 18. The air flows into the rear cavity 13, strikes the front face of the disc 29 and is deflected laterally where it is vented through the ports 31. Due to the high velocity of the projectile the air flows through the fuse at great speed and reduces the pressure on the front face of the disc below atmospheric pressure which is acting on the rear face of the disc. As a consequence of the unbalanced pressures on the disc the striker which is part of the disc is held in its forward position and the point 27 of the firing pin is maintained out of contact with the primer 11.

Upon impact with a target, such as the fabric of aircraft, the flow of air is cut off, the pressure on opposite faces of the disc becomes equalized and a very slight resistance to forward movement of the striker will force it rearwardly until the firing pin functions the primer 11.

I claim:

1. In a fuse, a body having front and rear chambers and a central passage connecting the chambers, a nose closing the front chamber and having a central passage, a tube disposed in the central passage of the nose and body, a collar on the tube engageable with the nose, segments between the collar and the body, a set-back sleeve in the front chamber having a shearable connection with the segments, a spring for moving the sleeve free of the segments, a firing pin carried axially by the tube and extending into the rear chamber, a disc carried by the firing pin and disposed in the rear chamber in spaced relation to the front wall thereof, and means for venting the rear chamber at its front part.

2. In a fuse, a casing having a chamber with

vents at its front part, a tube slidably mounted in the casing and adapted to conduct air to the chamber, means releasable during flight for normally holding the tube in forward position, a firing pin carried by the tube and extending into the chamber, a disc carried by the firing pin and disposed in the front part of the chamber and in rear of the vents so as to receive the air on its front face and deflect it to the vents.

3. In a fuse, a casing having a chamber with vents at its front part, an impact striker slidably mounted in the casing and having a passage for conducting air to the chamber, means releasable during flight for normally holding the striker in forward position, and a disc carried by the striker and disposed in the front part of the chamber and in rear of the vents so as to receive the air on its front face and deflect it to the vents.

4. In a fuse, a casing having a chamber with vents at its front part, a striker slidably mounted in the casing, releasable means for normally holding the striker in forward position, a disc carried by the striker and disposed in the front part of the chamber in rear of the vents, and means for conducting and entering air stream over the front face of the disc whereby the pressure on said face is reduced below atmospheric pressure.

5. In a fuse, a casing, a movably mounted disc in the casing, releasable means for normally holding the disc in forward position, means for conducting air into the casing at high velocity and on to the front face of the disc and means for venting the air deflected by the front face of the disc whereby the pressure on the front face of the disc is reduced below atmospheric pressure.

VIRGIL R. REED.