

(19)
(12)

(KR)
(A)

(51) 。 Int. Cl. ⁷
H04R 9/02

(11)
(43)

2002 - 0004684
2002 01 16

(21) 10 - 2000 - 0038814
(22) 2000 07 07

(71)

85 - 12

(72)

456 17

697 1 113 602

(74)

:

(54)

가

3

1

$$SPL = 94 + 20 \log_{10} \left(\frac{\rho_0 a^2}{2rM_0} \right) + 10 \text{LOG}_{10} \left(\frac{W_E \cdot G}{\sigma} \right)$$

0, G, a, WE, M0, r (가), (1) (9) (11) (11)가 (3)

가

가

가

1

2

2 가 2

3 4 , 1 2 3 4

1

3 1

3 , (100) , (110) , (120)

(110) (7) (4) (5)

(110) (9)

(120) (121) , (110) 가 (121)

(125) (123) , (3) (125) (3) (121) 가

(120) (125) (121)

(110)

2

4 2

4 , (200) (210) , (220) (210)

(7) (4) (5) (9) (220)

(221) , (210) 가 (221)

(223) , (300) (221) 2 (

225)

1) (300) (220) 2 (223)가 (220) 2 (225) (30

(303) (303) 가

(57)

1.

,
 ,
 ,
 가

2.

1 ,
 ,
 가

3.

,
 ,
 ,
 가

1 ,
 2 ,
 ,
 2 가 2

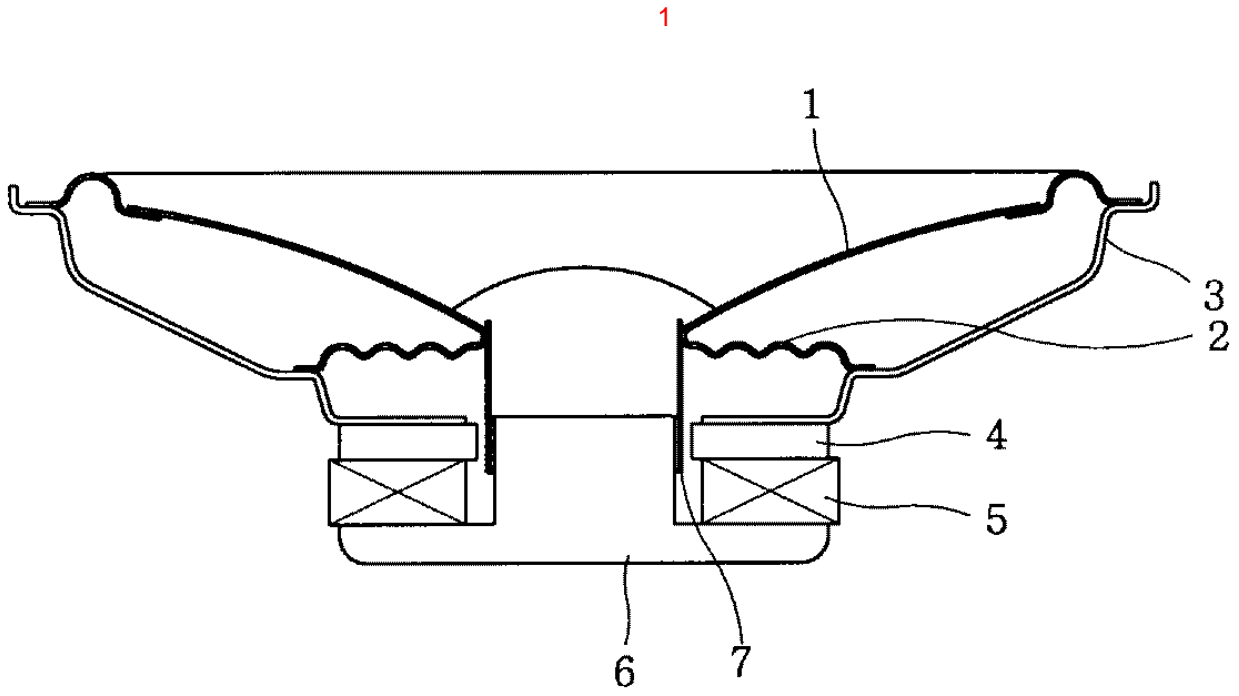

2

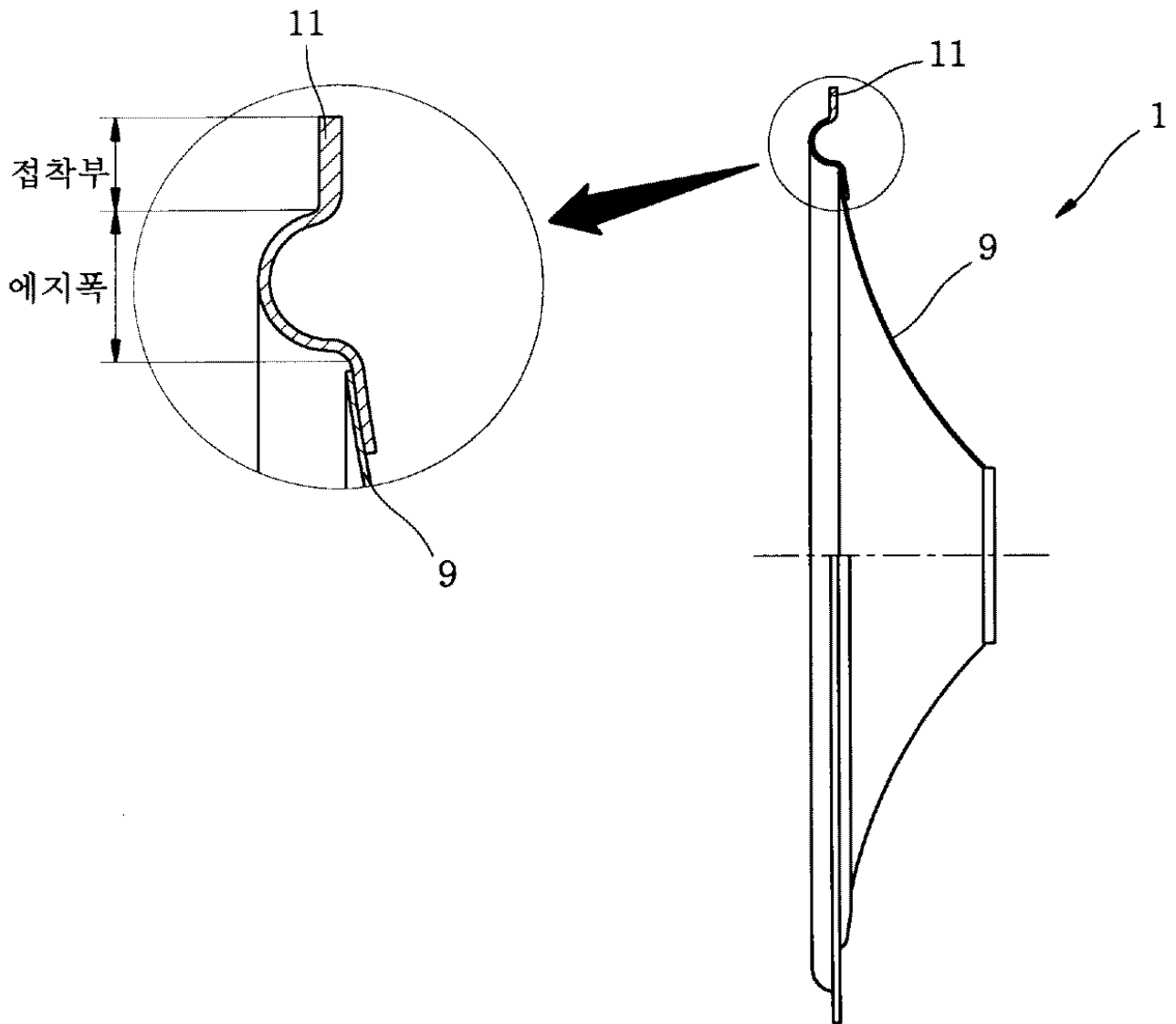

3

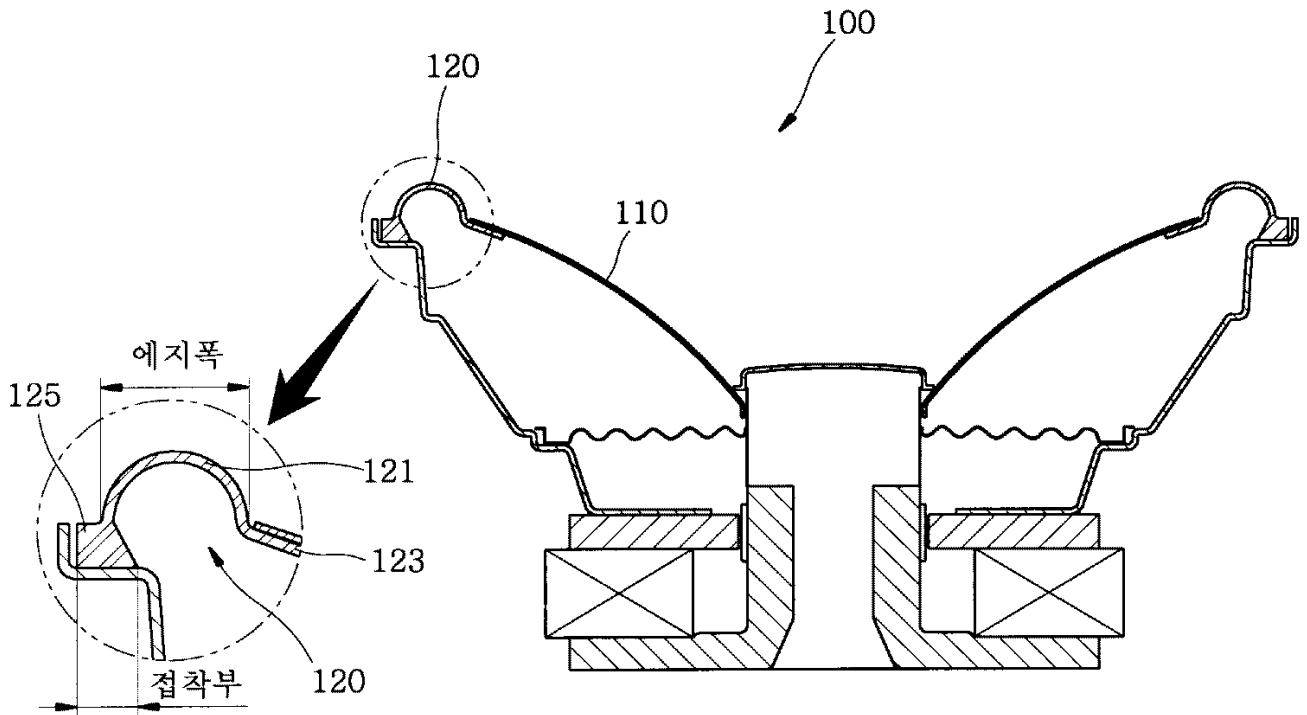

4

