

(19) World Intellectual Property Organization
International Bureau



(43) International Publication Date
2 September 2004 (02.09.2004)

PCT

(10) International Publication Number
WO 2004/073580 A1

(51) International Patent Classification⁷: A61H 31/00,
A61N 1/39

(21) International Application Number:
PCT/US2004/004097

(22) International Filing Date: 11 February 2004 (11.02.2004)

(25) Filing Language: English

(26) Publication Language: English

(30) Priority Data:
60/447,587 14 February 2003 (14.02.2003) US
10/652,148 29 August 2003 (29.08.2003) US

R. [US/US]; 18130 NE 154th Street, Woodinville, WA 98072 (US). STICKNEY, Ronald, E. [US/US]; 23014 102nd Place West, Edmonds, WA 98020 (US). NOVA, Richard, C. [US/US]; 1205 Kirkland Avenue, Kirkland, WA 98033 (US). RADONS, Stephen, W. [US/US]; 12602 198th Street SE, Snohomish, WA 98296-9706 (US). EDWARDS, Craig, D. [US/US]; P.O. Box 729, Fall City, WA 98024 (US). JAYNE, Cynthia [US/US]; 5524 161st Place NE, Redmond, WA 98052 (US). SULLIVAN, Joseph, L. [US/US]; 13829 101st Place NE, Kirkland, WA 98034 (US). SJOQUIST, Steven, E. [US/US]; 4427 154th Place SW, Lynnwood, WA 98037 (US).

(74) Agents: TAYLOR, Craig, F. et al.; Fredrikson & Byron, P.A., 4000 Pillsbury Center, 200 South Sixth Street, Minneapolis, MN 55402-1425 (US).

(71) Applicant (for all designated States except US):
MEDTRONIC PHYSIO CONTROL CORPORATION [US/US]; 11811 Willows Road NE, P.O. Box 97006, Redmond, WA 98073-9706 (US).

(81) Designated States (unless otherwise indicated, for every kind of national protection available): AE, AG, AL, AM, AT, AU, AZ, BA, BB, BG, BR, BW, BY, BZ, CA, CH, CN, CO, CR, CU, CZ, DE, DK, DM, DZ, EC, EE, EG, ES, FI, GB, GD, GE, GH, GM, HR, HU, ID, IL, IN, IS, JP, KE, KG, KP, KR, KZ, LC, LK, LR, LS, LT, LU, LV, MA, MD, MG, MK, MN, MW, MX, MZ, NA, NI, NO, NZ, OM, PG,

(72) Inventors; and

(75) Inventors/Applicants (for US only): HAMPTON, David,

[Continued on next page]

(54) Title: COOPERATING DEFIBRILLATORS AND EXTERNAL CHEST COMPRESSION DEVICES

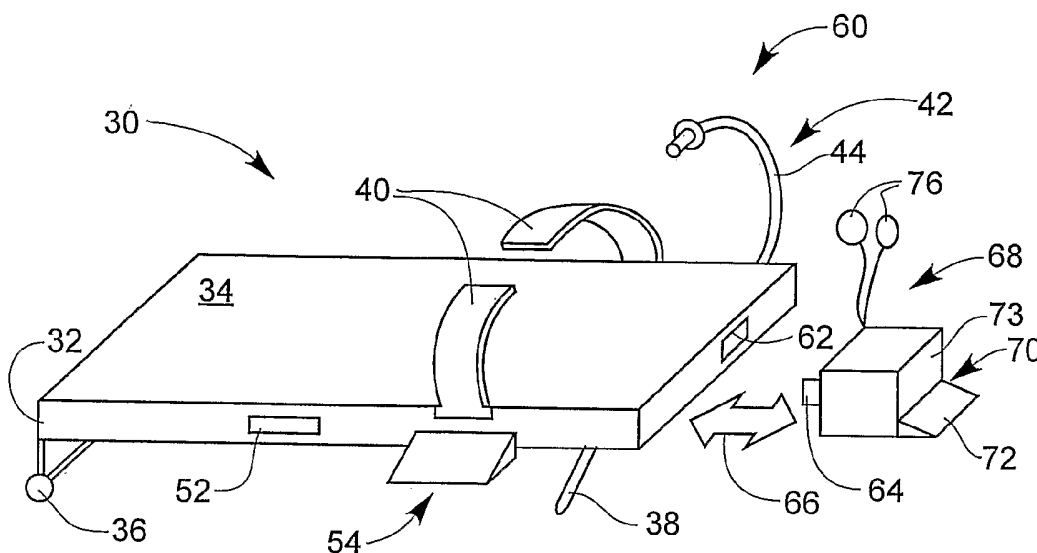

(57) Abstract: Devices for providing communicating external chest compression (ECC) devices (30) and defibrillation (DF) devices (68), where the ECC and DF devices can be physically separate from each other. Both ECC and DF devices are able to operate autonomously, yet able to communicate and cooperate with each other. Some ECC and DF devices are adapted to be physically and/or electrically coupled to each other. One ECC device includes a backboard (32), a chest compression member (40), a communication module (62), controller, and at least one sensor, electrode lead or electrode. One DF device includes a defibrillator module, a controller, and a communication module (64) that can communicate with the ECC communication module. The communicating ECC and DF devices may deliver ECC, pacing, defibrillation, ventilation, and cooling therapies, and may deliver instructions to human assistants, in a coordinated and cooperative fashion.

WO 2004/073580 A1



PH, PL, PT, RO, RU, SC, SD, SE, SG, SK, SL, SY, TJ, TM, TN, TR, TT, TZ, UA, UG, US, UZ, VC, VN, YU, ZA, ZM, ZW.

TR), OAPI (BF, BJ, CF, CG, CI, CM, GA, GN, GQ, GW, ML, MR, NE, SN, TD, TG).

(84) Designated States (*unless otherwise indicated, for every kind of regional protection available*): ARIPO (BW, GH, GM, KE, LS, MW, MZ, SD, SL, SZ, TZ, UG, ZM, ZW), Eurasian (AM, AZ, BY, KG, KZ, MD, RU, TJ, TM), European (AT, BE, BG, CH, CY, CZ, DE, DK, EE, ES, FI, FR, GB, GR, HU, IE, IT, LU, MC, NL, PT, RO, SE, SI, SK,

Published:

— *with international search report*

For two-letter codes and other abbreviations, refer to the "Guidance Notes on Codes and Abbreviations" appearing at the beginning of each regular issue of the PCT Gazette.

COOPERATING DEFIBRILLATORS AND EXTERNAL CHEST COMPRESSION DEVICES

BACKGROUND OF THE INVENTION

Field of the Invention

5 The present invention is related to the field of resuscitation devices.

Description of the Related Art

All over the world, people experience resuscitation events. For example, both in and out of the hospital, there is a significant incidence of cardiac and/or respiratory arrest among at-risk patients. When an acute event occurs, a variety of
10 therapies may need to be administered to restore the patient's normal function. The patient may require artificial respiration to stimulate breathing, chest compressions to restore perfusion, defibrillation to activate the heart, and/or pacing to promote cardiac output.

Many devices exist which can separately administer these therapies in
15 these events and situations. For example, an automated chest compression device is taught in patent US 6,234,984 B1. Some of these devices even aggregate various features, such as are described in U.S. Patent No. 4,349,015, and U.S. Patent No. 4,424,806.

Many of the prior art devices, however, merely collect such features into a
20 single package, without synchronizing their functions and making them work together. Therefore there exists a need for devices that can combine, coordinate and integrate various aspects of these diagnostics and therapies to better assess and treat the patient. That is because many of these conditions occur in combination, requiring that therapies blend constructively with one another to be
25 optimally effective.

SUMMARY OF THE INVENTION

Generally, the present invention provides devices, software, and methods as described below. The invention offers devices that can operate independently, or in a combined fashion, to monitor a patient and administer diverse therapies, as
30 they arise. Systems provided by the present invention preferably include a device for providing external chest compression and a defibrillator, where the chest compression device and defibrillator can each operate autonomously when necessary, yet can also each communicate with and cooperate with each other when advantageous.

One system provided by the present invention includes an external chest compression (ECC) device having a first communication module, and a defibrillator having a second communication module, in which the ECC device and the defibrillator are capable of communicating via the first communication module and the second communication module. The data communication modules can utilize a communications medium selected from the group consisting of wireless, radio frequency, infra-red light, light, hard-wired electrical, and coupled optical fibers.

Some ECC devices include a backboard, and can also include wheels and a handle. A chest compression member can be coupled to the backboard, where the chest compression member can include a rigid chest compression member and/or a retractable or contractible belt or vest. Some chest compression members are driven by powered actuators while others are manually operable. ECC devices can also include cooling modules for cooling a person and ventilators for ventilating.

ECC devices, on the backboard, on the chest compression members, and/or on the defibrillation device, can include various sensors, electrodes, and leads, which can include sensors for measuring physiological attributes, one or more defibrillation electrodes, and one or more ECG leads. Electrodes may include a releasable electrolyte. Sensors can measure applied chest pressure, temperature, respiration, pulse, ECG signals, EEG activity, thoracic impedance, and other parameters. The sensors, electrodes, and leads are preferably coupled to the communication module of the respective ECC or defibrillation device. Some systems include a communication module on either or both of the ECC device and defibrillator that can communicate with a remote assistance center. A camera can be coupled to the communication module.

Some ECC devices and defibrillators are adapted to be physically and/or electrically coupled to each other. Some defibrillators can be electrically coupled to defibrillation electrodes on the ECC device.

The ECC device and/or the defibrillator preferably includes a controller or processor that is coupled to the respective bidirectional communication module. In systems having at least two controllers, each controller may execute logic to

designate a master controller, and also slave controllers, as between the two or more controllers. Various methods may be executed in the controllers, including the master and/or slave controllers, depending on the embodiment.

5 One method according to the present invention includes placing a person on a first device, establishing data communication between the first device and a second device that can be physically apart from the first device, causing a chest compression member of the first device to compress the chest of the person against the backboard, and causing a defibrillator of the second device to defibrillate the person responsive to the communication. Placing the person on the
10 first device can refer to placing the person on a portion of the first device, for example on a backboard, or on a vest or belt which encircles the person. Some embodiments utilize a constrictive vest or belt and do not include a backboard or backframe. The communication may be used either to synchronize the delivery of the defibrillator shock with an optimal time in the compression cycle, or to avoid
15 applying the defibrillator shock at a vulnerable period in the compression cycle. The communication about defibrillator activity may, in turn, be used to initiate, pause, or terminate chest compressions, or to change operating parameters of the ECC device, such as rate and/or depth of chest compression. In some methods, placing the person on a backboard of the first device results in the person
20 contacting a defibrillator electrode of the first device.

Some methods include therapies, including pacing, ventilating, cooling, and other modalities, and providing ECC responsive to data communicated between or among the separate devices. The therapies performed on the person can be automatic, manual, or prompted manual mode, in response to voice instructions
25 from any of the devices.

Some systems include a controller executing logic for generating an output to control a chest compression actuator in combination with a defibrillator, responsive to sensor data indicative of the presence of cardiac arrest and that indicate the response of the patient to therapy.

30 In one example, a sensor may detect that a patient is in cardiac arrest (for example, some combination of asystole or VF on the ECG, lack of a pulse, and no respiratory and/or EEG signal) or pulseless electrical activity (PEA) (for example,

some combination of R-wave activity on the ECG and lack of a pulse).

Alternatively, the sensor may detect that the patient has a perfusing rhythm, such as sinus activity (for example, R-wave activity, a regular pulse, and adequate respiration.)

5 Perfusion may be stimulated when controllers execute logic in response to sensor inputs to implement methods to administer automatic chest compressions, as in cardiac arrest or PEA. Further sensor readings can establish whether adequate perfusion has been stimulated, for example, by the return of pulse or EEG signals, and the device may recommend or self-adjust based on sensor
10 readings to set an optimal rate and / or depth of chest compression. Some indication of the adequacy of perfusion and the course of ECC therapy can be indicated to the operator and stored to a documentation log.

 Similarly, it may be determined that defibrillation is required in order to restore spontaneous cardiac contractions and to restore cardiac output. Sensors
15 may initiate defibrillation responsive to physiological signals indicative of ventricular fibrillation or ventricular tachycardia. A defibrillation shock can be administered under manual or automatic control, synchronized to the activity of the ECC device, and the response of the patient can be determined by further reference to the sensors (e.g. pulse or ECG).

20 Again, sensors may indicate that a patient is failing to ventilate properly, or only with difficulty. Manual or automatic ventilation may be initiated in conjunction with, and the effectiveness determined by reference to sensors (e.g. CO₂ or oximetry). Optimal rate and depth, or possibly gas mixture, may be determined and recommendations made to the operator. The interaction between sensors
25 and therapies may again be used to establish a care record in a documentation log. Similarly, other adjunct therapies (hypothermia and others) may be applied when the sensors indicate that their effect is beneficial and safe for the patient. ECC may be started, paused, or stopped in relation to these adjunct therapies.

 Each independent therapies may be applied alone or in combination. But a
30 patient in cardiac arrest may benefit most from a synchronized combination of therapies, based on sensor readings. This could occur when a patient has been placed on an ECC device and instructions generated to establish communication

between a first data communication module operably coupled to the ECC device and a second data communication module coupled to a defibrillator. Sensors may determine that a patient is in cardiac arrest, and, for example, may further indicate that the patient has been in a non-perfusing state for a period longer than 5
5 minutes. The device would recognize that a period of chest compressions should be initiated, sufficient to perfuse the patient, for two minutes before applying a defibrillation shock. The effectiveness of chest compression could be monitored, and the duration of stimulated perfusion measured. After two minutes, a defibrillation shock could be automatically applied. It may be desirable to initiate
10 the shock during a chest compression, or between them, with such synchronization being performed to enhance shock effectiveness. Sensors detecting the re-appearance of a perfusing ECG rhythm may initiate a 30-second period of pacing to further stimulate cardiac function. Alternatively, failure to restore a perfusing rhythm may cause a further period of CPR, followed by
15 another defibrillation shock, to be administered. In all cases, available therapies can be synchronized and combined in ways responsive to the patient's condition, and in ways that complement each other's effectiveness.

DESCRIPTION OF THE DRAWINGS

Figure 1 is a perspective view of a system including a cooperating,
20 communicating, and physically separate external chest compression (ECC) device and defibrillation device;

Figure 2 is a perspective view of the system of Figure 1, having a person disposed on the ECC device, and the ECC and defibrillation devices directly coupled to each other;

25 Figure 3 is a perspective view of a person disposed on another system ECC device having a shorter backboard relative to the ECC device of Figure 1, and having the defibrillation electrodes on the person; and

Figure 4 is a transverse, cross-sectional view of an ECC device in which the chest compression member includes a belt and a piston;

30 Figure 5 is a transverse, cross-sectional view of an ECC device in which the chest compression member includes a retractable belt;

Figure 6 is a transverse, cross-sectional view of an ECC device in which the chest compression member includes rigid members pivotally coupled to the backboard;

Figure 7 is a transverse, cross-sectional view of an ECC device having a
5 powered actuator coupled to a force multiplier for delivering chest compression;

Figure 8 is a perspective view of a system including a cooperating external chest compression (ECC) device and a separate defibrillation device, in which the ECC device includes a posterior electrode in the backboard and an electrical connection coupled to the defibrillation device;

10 Figure 9 is a fragmentary, perspective view of a system including a cooperating external chest compression (ECC) device and a separate defibrillation device, in which the ECC device includes electrodes for receiving defibrillator paddle electrodes for electrically coupling to the defibrillation device;

Figure 10 is a fragmentary, bottom view of a belt bearing a defibrillator
15 electrode;

Figure 11 is a fragmentary, bottom view of a belt bearing two defibrillator electrodes;

Figure 12 is a fragmentary, bottom view of a belt bearing multiple ECG
leads;

20 Figure 13 is a fragmentary, bottom view of a belt bearing multiple sensors and associated leads;

Figure 14 is a fragmentary, transverse cross-sectional view of a belt or vest bearing a spring biased defibrillator electrode, ECG lead, or sensor;

25 Figure 15 is a fragmentary, transverse cross-sectional view of a belt or vest bearing an electrode, lead, or sensor having an electrolyte gel;

Figure 16 is a schematic view of an ECC device and defibrillator similar to those Figure 1, further including communication modules in communication with a camera and transmitter communicating with a remote assistance center;

30 Figure 17 is a schematic view of the ECC device of Figure 1, further including a cooling module in the form of a cooling garment disposed on the person;

Figure 18 is a highly diagrammatic, cross-sectional view of the person and cooling garment of Figure 17;

Fig. 19 is a view of a sample screen of a defibrillator according to the invention, when it requests cooperation with an ECC device according to the invention;

Fig. 20 is a view of a sample screen of the ECC device of Fig. 19, when the request is received;

Fig. 21 is a view of a sample screen of the defibrillator of Fig. 19, as the handshake is being established;

Figure 22 is a block diagram of the controller or computer containing executable logic or software contained within an ECC and/or defibrillation device;

Figure 23 is a flow chart illustrating a method for performing coordinated external chest compression and defibrillation therapies;

Figure 24 is a time diagram showing coordinated periodic chest compressions and defibrillation and/or pacing pulses;

Figure 25 is a flow chart segment illustrating an optional pacing portion of the flow chart of Figure 18; and

Figure 26 is a view of a display screen from an operation of the invention.

DETAILED DESCRIPTION

According to the invention, an external chest compression (ECC) device is provided, and also an external defibrillator. In addition, each has an interface for communicating with the other, and optionally also for cooperating for maximum effect. The interfaces are made compatible with each other, as further described below.

An important aspect of the invention is that the external defibrillator is capable of functioning autonomously, independently of the external chest compression device when they are not communicating or cooperating. It is also highly preferable that the external chest compression device be capable of functioning autonomously, independently of the external defibrillator when they are not communicating or cooperating.

Figure 1 illustrates a system 60 for performing coordinated ECC and defibrillation including an external chest compression (ECC) device 30 and an

external defibrillation device 68. ECC device 30 includes a backboard or back frame 32, chest compression members 40, a ventilator 42, an ECC human interface module or I/O module 54, and a communication module 62 for communicating with external defibrillation device 68.

5 Backboard 32 is shown as solid and having an upper surface 34. Backboard 32 need not be solid. Backboard 32 is preferably made as lightweight as possible, allowing the integrated modules to be included without adding unneeded weight. In some embodiments, wheels 36 and a handle 38 are coupled to backboard 32. This permits the device to be used as a gurney, making it easier
10 to transport the patient.

 The chest compression portion may be implemented in a number of ways, as described below. Two chest compression members 40 are shown, in the form of two arms. Chest compression members 40 are coupled to backboard 32. Even though only two arms are shown, the chest compression members may be
15 implemented as a belt, and/or as a vest, either a full or partial vest. The belt or vest is intended to generally wrap around the chest of the patient, for squeezing it, or squeezing it against backboard 32. In this way, ECC or CPR can be administered to the patient. The belt or vest may incorporate other functionalities, as further described below. In addition, it may be removable and/or reusable.

20 ECC device 30 can further include ventilator or ventilating module 42. Ventilator 42 can include ventilator tubing 44. Ventilator 42 can also be coupled to backboard 32 and can be used for ventilating the patient. Ventilator 42 is shown schematically, as ventilators are well known to those skilled in the art.

 Human interface module 54 can be implemented in a number of ways.
25 Human interface module 54 can include an input portion and an output portion. The input portion can include a keyboard and the output portion can include a visual display or computer screen and/or a voice output module for interacting with a human assistant. Human interface module 54 can have input devices such as keys, switches, knobs, levers, and a microphone for recording and preferably also
30 voice recognition. The human interface device can also have output devices such as one or more display screens, a speaker, a printer, and other output devices.

All of these functions may be aggregated at the human interface module, for example, using a keypad.

In addition, the ECC device may include advanced features for availing to a defibrillator, when one is coupled with it. This may be useful when the defibrillator is a unit that lacks many capabilities on its own. Having these features permits using a defibrillator that itself lacks these features.

A battery 52 can be carried within backboard 32 for supplying power for operating human interface device 54, ventilator 42, and chest compression members 40, in the various embodiments of the invention. In some systems, battery 42 can also be used to power the external defibrillator, where the defibrillator can be electrically coupled to the ECC device. A controller or computer can also be included within human interface device 54 or elsewhere within ECC device 30 for coordinating the operation of external chest compression, defibrillating, pacing, and ventilating, depending on the embodiment of the invention present.

External defibrillation device 68 includes a defibrillation human interface 70 including an input portion 72 and an output portion 73. The input portion can include a keyboard and the output portion can include a visual display or computer screen and/or a voice output module for interacting with a human assistant. Defibrillation device 68 also includes defibrillation electrodes 76 and a defibrillation communication module 64. Defibrillation communication module 64 may be seen communicating with ECC device communication module 62 through communication channel 66.

Figure 2 illustrates system ECC device 30 having a person or patient 100 disposed on backboard 32. Patient 100 has a chest disposed under chest compression members 40 and a mouth for receiving ventilator tubing 44. Defibrillator device 68 has been moved toward ECC device 30. In some embodiments, ECC device and defibrillator device 68 can be electrically and/or mechanically coupled to each other through electrical connectors and/or cables, allowing defibrillation pulses from the defibrillator to be delivered through defibrillation electrodes of the ECC device.

Figure 3 illustrates another system including an ECC device 120, for providing cooperating external chest compression and defibrillation and/or pacing. ECC device 120 may be seen to include chest compression members 40, human interface device 54 and battery 52, as previously described with respect to Figure 1. ECC device 120 includes a short backboard or back frame 126. Shorter backboard 126 can decrease the weight and increase the portability of the ECC device.

Compressing and releasing may be performed according to any type of time profile. One such profile is seen in Figure 24. Other profiles may be sine wave, triangular shaped, or other shapes. In an advantageous embodiment of the invention, a sine wave may be used with a frequency outside the ECG range. The chest compression profile shape and frequency may permit analyzing the ECG while simultaneously performing chest compressions. This may also permit the device to detect more quickly a rhythm that requires a defibrillation shock, and to reduce the delay of its delivery from the end of the chest compressions.

Other embodiments of the chest compression portion includes devices performing active compression decompression, devices that combine chest compressions with abdominal compressions, devices where the belt is operated electronically (w/o gears), and devices that use electricity to do chest compressions by electrically inducing chest muscles to contract.

Referring again to Figures 1, 2, and 3, the invention external defibrillation device is capable of performing defibrillation, and optionally, also pacing. Pacing may be implemented by a separate module than defibrillating, but it is highly advantageous to have the same module perform both functions. The defibrillator may be of any chosen automation level. That includes operation that is fully automated to fully manual, and every option in between.

Moreover, the defibrillator may also advantageously provide devices or modules that perform monitoring, and further provide interpretation of the monitored signals. The monitoring results may advantageously be displayed on the human interface device previously described or on an I/O module as described below. In other embodiments, there is a separate monitoring module. Monitoring may be of any of the monitoring parameters or physiological attributes

common on defibrillator/monitors or bedside monitors today, for example, NIBP, SpO₂, CO₂, 12 lead ECG, etc. In other embodiments, monitoring is performed by the ECC device, and may be transmitted to the defibrillator.

The defibrillator also can include an input/output (I/O) or human interface module as previously described. In the embodiment of Figure 1, defibrillator human interface device 70 includes a display screen and keyboard, as previously discussed, but that is not limiting. The invention can also have input devices such as keys, switches, knobs, levers, a microphone for voice recording, and preferably also voice recognition, and output devices such as one or more screens, a speaker, printer, or other output device. All of these are preferably aggregated at the I/O module, but that is not necessary for practicing the invention. They may be located elsewhere in the devices, or received remotely, for example, wirelessly.

The ECC device also optionally includes a ventilation portion. A ventilation portion or ventilating module 42 was previously described with respect to Figure 1. The ventilation portion may be implemented either automatically, or be intended for use by a human operator. If by a human, the device may be made giving prompts for instructing the rescuer. The prompts may be timed. The rescuer may be either performing mouth-to-mouth resuscitation or opening a bag valve mask device where the user manually squeezes the bag. If the ventilator is to be automatic, a tube can be inserted into the patient's mouth, and a pump can be used. A mask may be placed on the face of the patient. The oxygen can be delivered this way to the patient. Other devices, such as valves that block the airway during chest decompression, for example, a CPR-x valve, can be included in the ventilation portion of the device of the invention.

The ECC device preferably also includes an electrical power source for powering the various ECC portions. The power source may be a battery, such as battery 52 discussed with respect to Figure 1. The battery may be either a rechargeable battery for maximum portability, or a replaceable battery. The battery is preferably integrated with the back frame, either permanently, or in such a way that it can be removed and replaced. Some devices of the invention have the benefits of being able to share a common power source, CPU or controller, and I/O module for the interface with the rescuer.

Figure 4 illustrates an ECC device 150, in which the chest compression is effected by a compressor or expandable member held in place by a belt or vest 153, depending on what is provided in the particular embodiment. The chest compressor includes a mechanism for pushing downwards on the chest. In the
5 ECC device illustrated, the compressor is implemented as a base 151 and a piston 152. Piston 152 is illustrated in a first, retracted position 154 and a second, extended position 156. Belt or vest 153 can be coupled to a back frame 158, as previously discussed.

Figure 5 illustrates a belt or vest 172, having a buckle or zipper 174 for
10 fastening around the chest of the patient. Belt or vest 172 can itself be contracted to effect chest compression. The contraction can take place in many ways. In one way, the belt or vest can be retracted into a back frame 176. In another way, belt or vest 172 can be constricted about the patient. Belt or vest 172 may be seen having a first, expanded position 173 and a second, constricted position 178.
15 In yet another way, chest compression is effected by electrically stimulating the chest muscles.

Figure 6 illustrates still another ECC device 200 having a patient 206 disposed on a backboard 210. In device 200, chest compression is provided by rigid chest compression members or arms 202 having support prongs 208 that
20 push down on the chest of patient 206. Arms 202 can be pivotally coupled to backboard 210. In the embodiment illustrated, arms 202 are operated by gears 204 that are integrated with backboard 210. In some embodiments, arms 202 are driven by a powered chest compression actuator.

Figure 7 illustrates another ECC device 220 including backboard 210
25 carrying patient 206, as previously described. ECC device 220 includes a force multiplier 224 using a lever arrangement, so that a pressing member can exert a downward pressure on the patient chest. ECC device 220 includes a gearbox or a powered actuator 230 coupled through a shaft or rod 228 that may be hollow in some embodiments. Shaft 228 can have first force transmission member 236
30 slidably received within shaft 228 and pivotally coupled to a second force transmission member 232 and a third force transmission member 234. Force transmission members 232 and 234 can be further coupled to a chest

compression pad 235 for pressing against the chest of patient 206. Force multiplier device 224 can be held in place by a belt or vest 222. In some embodiments, the lever arrangement may operate by having a rod conduct a long rotation, such as in a corkscrew arrangement.

5 Other embodiments of the chest compression portion include belts crossing the chest from over the shoulder down to the chest, forming an "X" across the patient's chest. This is better than the conventional way of having belts horizontally across the patient's chest, in that it permits placement of sensors such as leads in different places. Alternately, an "X"-belt configuration may be
10 combined with the conventional configuration. In yet other embodiments, the chest compression portion includes devices performing active compression-decompression, devices that combine chest compressions with abdominal compressions, devices where the belt is operated electronically without gears, and devices that use electricity to do chest compressions by electrically inducing chest
15 muscles to contract. Various embodiments may use combinations of these chest compression techniques.

Figure 8 illustrates a system 250 including an external chest compression (ECC) device 252 and an external defibrillation device 254. ECC device 252 can have backboard 32, human interface device 54, and ECC data communication
20 module 62, as previously described. ECC device 252 further includes chest compression members 256 having a built in electrode 264 on the underside, and a posterior electrode 262 built into the backboard, for availing to a defibrillator, when one is coupled with it. Electrodes 264 and 262 are placed on the patient by virtue of applying the ECC device. In the example illustrated, one electrode can be
25 integrated with the chest compression portion, and the other on the back frame. In another example, both electrodes may be integrated with the chest compression portion. Instead of applying the external defibrillator electrodes to the patient, special wires can be applied from the external defibrillator to a defibrillator electrode interface or connector 260 on the back frame. Those in turn
30 can power the ECC device built in electrodes. In the embodiment illustrated, an electrical cable 266 may be seen extending from defibrillator 254 to ECC device 252.

Referring to Fig. 9, an optional embodiment is shown. An ECC device 222 includes two electrodes 274 on the back frame for placing thereon directly the defibrillator electrodes 258. This way, no special wires are needed.

Figure 10 and 11 illustrate how defibrillator electrodes or other electrodes
5 might be attached to an underside of the vest or belt of the chest compression portion of the devices of Figures 1, 2, or 3. For example, the electrodes can be part of a belt or vest of Figures 4 or 5. The electrodes can also be integrated with an arm or a prong of a chest compression member, for example, prong 208 of Figure 6 or chest contact pad 235 or Figure 7.

10 Figure 10 illustrates a belt or vest having a first portion 300 coupled through a buckle or zipper 304 to a second portion 302. A first electrode 306 may be affixed to the underside of the belt or vest and coupled to a wire or lead 308. In Figure 10, one of the electrodes is situated on the underside of the belt or vest, while the other electrode may be expected to be in the backboard. At least one
15 wire can connect the electrode to the remainder of the defibrillation/pacing portion. This is a preferred embodiment, since it would minimize CPR artifact in the ECG signal. The electrode preferably avoids the center of the chest. That is where the buckle or zipper is shown (as wider than the open portion that supports the electrode).

20 Figure 11 illustrates the belt or vest of Figure 10, having belt or vest first portion 300, buckle or zipper 304, and second portion 302. First electrode 306 and wire 308 are as previously described with respect to Figure 10. In Figure 11, a second electrode 310 is coupled to a second wire or lead 312. In the embodiment illustrated in Figure 11, no electrode is needed in the backboard or
25 back frame for traditional defibrillation. At least one wire can connect each electrode to the defibrillation/pacing portion.

Figure 12 illustrates the underside of another belt or vest having a first
portion 320 coupled through a buckle or zipper 324 to a second portion 322. Belt
or vest first portion 320 may be seen carrying a first electrode 326 and a second
30 electrode 327, coupled to wires 332. Belt or vest second portion 322 may be seen carrying third electrode 328, fourth electrode 329, and fifth electrode 330, all coupled to wires 332. Wires 332, while having similar reference numbers, are, of

course, preferably electrically distinct. The ECG leads of Figure 12 are also preferably integrated with the underside of the vest or belt of the chest compression portion of the devices of Figures 1, 2, or 3. The ECG leads may be placed so as to not interfere with any defibrillation electrodes, for example, those
5 of Figures 10 and 11.

Figure 13 illustrates yet another belt or vest having a first portion 340 coupled through a buckle or zipper 344 to a second portion 342. The underside of belt or vest first portion 340 may be seen carrying a first sensor 346 coupled to a wire or other signal transmission medium 349. The underside of belt or vest
10 second portion 342 may be seen carrying a second sensor 347, and a third sensor 348, coupled to wires 349. The sensors are preferably also integrated with the underside of the vest or belt of the chest compression portion of the devices of Figures 1, 2 and 3. These sensors can include pulse detection sensors, such as those made from piezoelectric materials, temperature sensors, CO₂ sensors, and
15 other sensors for measuring physiological attributes or signals, well known to those skilled in the art.

The features integrated with the belt or vest are preferably arranged so that they do not interfere with each other. The electrode may be fully integrated, or detachable for servicing. Alternately and equivalently, some electrodes, ECG
20 leads, or sensors may be hosted in the backboard.

Figures 14 and 15 illustrate how defibrillator electrodes, ECG leads, or sensors may be integrated with an underside of the vest, belt, or other chest compression members, for example those in Figures 1, 2 or 3.

Figure 14 illustrates a belt or vest 350 carrying an electrode, lead, or
25 sensor 352. Electrode, lead, or sensor 352 can be coupled to a wire 356 and biased downward from the belt or vest with a spring 354, so as to be pressed against the chest of the patient. For use with a pulse sensor, some quieting time for the spring is preferably allowed, so as to not provide interference with the signal.

30 Figure 15 illustrates a belt or vest 360 carrying an electrode, lead, or sensor 362 on the underside of the vest or belt. A gel or electrolyte 364 may be seen on the underside of the electrode, lead, or sensor 362. For implementing an

electrode, a gel may be administered, or an electrolyte may be diffused. The gel or electrolyte may be provided in a capsule that bursts at an appropriate time to release it. The time may be prior to defibrillation electrotherapy. Bursting may be caused by the mere pressure against the chest, or by an appropriate electrical signal. One advantage that can be provided by some embodiments is that there is no need to disrobe the patient – the fluid may seep through the clothes to establish electrical conduction.

Figure 16 illustrates some other optional features of the invention. ECC device 30, patient 100, and backboard 32 are shown, as previously described. A camera 382 may be seen disposed on a post secured to backboard 32. Camera 382 can be coupled to a communication module 380 that can act as a transmitter or transceiver. Communication module 380 can communicate with a remote assistance center 396 coupled through a network 394 and a remote antenna 392. A data/voice/video communications link 386 is shown as existing between communication module 380 and remote assistance center antenna 392. Communication link 386 can be bi-directional in some embodiments.

A data/voice/video communications link 390 is shown as existing between communication module 380 and defibrillation device communication module 384. Yet another communication link 388 may be seen between defibrillation device communication module 384 and remote assistance center antenna 392. Communication links 390 and 388 are also preferably bi-directional. In a preferred embodiment, communications modules 380 and/or 384 include the functionality of a portable telephone and can establish wireless communication with remote antenna 392, and network 394 is a network that can support voice and/or data communications.

Camera 382 is preferably a digital camera, and may be either a video camera or a still camera. A camera may be advantageously attached to a post in the backboard and/or to the defibrillation device. The camera is preferably attached to the ECC device. The camera permits recording of the scene and the patient. The recording may be used for record keeping, event analysis, and other purposes. Alternately, the recording may be used for live transmission to the

remote assistance center 396, where more trained medical personnel can in turn provide feedback.

The user may use the defibrillator of the invention and/or the chest compression device of the invention to assist a victim. In addition, the user can
5 establish a communication link 386 and/or 388 with remote assistance center 396. Then the information can be transmitted and can include images, if a camera is provided. The patient's vital signs, encoded by the invention for communication, along with the rescuer's comments, observations, and even questions may be also transmitted to the remote assistance center.

10 If the defibrillator of the invention and the chest compression device of the invention are interfaced, then only one communication link need be established with the Remote Assistance Center. The inputs from the other device can be passed via the interface.

In some embodiments, the invention is operable from remote assistance
15 center 396. An operator at the remote assistance center can transmit a command code through communication link 392 to ECC device 30 and to the defibrillation device, and the devices operated accordingly. Such operation may actually include defibrillation and/or ECC.

Moreover, the monitored data, included also recorded data such as events,
20 wave forms, physiological signals or attributes, and data indicative of the device operation itself, may be also transmitted to a system for collecting or storing patient information, and to a computer-aided dispatch system for assistance. Furthermore, it may also be sent to a billing system for determining patient billing.

Figures 17 and 18 illustrate additional optional cooling figures of the
25 invention. Cooling can be provided for performing IMHT (Induction of Mild Hypo Thermia), which may slow down adverse effects of the events being experienced by the patient.

ECC device 30 and patient 100 are as previously described. Figure 17
illustrates generally a cooling module aspect of the present invention. In the
30 example illustrated, the cooling module includes a liquid gas storage container or tank 402 coupled to a valve 404 coupled in turn to a tube 406 coupled to a cooling garment 408. Liquid gas storage container 402 can be included within the cooling

module and is preferably carried under the backboard. This is most advantageous in the event the backboard is implemented with wheels.

The liquid in container 402 can be one that preferably turns into gas upon being released into the atmosphere. A cooling garment, similar to cooling garment 408, can be provided for each part of the body that is of interest to cool. As used herein, "cooling garments" include very loose, tent-type cooling garments that allow cool air to be blown over the patient. As used herein, "cooling garments" also include tightly adhering garments that may contact the patient's skin or clothing and conduct heat away through conductive cooling. Some tightly adhering cooling garments are adhesively adhered to the patient's skin and conduct heat away through a thermally conductive coupling agent. The cooling garment can be shaped to be suitable for placing over the bodily part that is to be cooled. Cooling garment 408 illustrated in Figure 17 is designed for placement on the patient's head. Cooling may also be accomplished by evaporative cooling, for example, using a suitable fluid delivery system and an absorber for alcohol, such as cotton.

Figure 18 illustrates a section of cooling garment 408. Garment 408 has an inner shell 409 for contacting patient 100. Garment 408 also has an outer garment or shell 411 that defines an inner space 405 between outer shell 411 and inner shell 409. Spacers may be used to maintain inner space 405 in an open configuration. Alternately, small tubes may be used. Garment 408 can receive liquid gas from storage container 402 via tube 406 in communication with inner space 405. The cooling gas or liquid can also be received into the series of small tubes, previously described. The gas can then be released into the atmosphere from various places in the garment. As it is being released, the gas can expand, cool, and thus draw heat away from the patient. Sensors, for example for temperature, may also be included.

Referring again to Figure 17, the gas can be directed from storage container 402 to liquid controller or valve 404, and from there to garment 408 via tube 406. Liquid controller 404 can in turn be controlled by an IMHT controller, for controlling the rate of cooling of the patient. The expanded cooled gas may be mixed with air to control the final cooling gas/air temperature. The IMHT controller

may be implemented in combination with the liquid controller, and optionally further communicates with the processor or controller of the device of the invention.

5 In some embodiments (e.g. Fig. 2) the interface is physical, and the devices are physically coupled to each other. In direct coupling embodiments, the external defibrillator may slide into a sheath of the back frame, and snap in place, making the required contacts. In other embodiments, the external defibrillator is coupled with the back frame via one or more wires. A physical interface is necessary if a defibrillation shock is to be transmitted, as in Fig.8.

10 In other embodiments (e.g. Fig. 3) the interface is wireless, and the devices communicate without contacting each other. In that case, the defibrillator electrodes are applied directly to the patient. Allowance must be made for not interfering with the ECC device.

15 If the interface is wireless, it may use any one of many known technologies and protocols for wireless communication. Favored technologies are those that permit communication between devices that are within 10m (30 feet) from each other, such as 802.11 compatible devices, Bluetooth devices, etc.

20 The interface can be established in many different ways. In the most advanced embodiments, both devices may exchange data with each other, and either may exercise control of the other. In other embodiments, either one of the devices of the invention may communicate to the other, but be able to receive no commands. Or they may be able to receive commands, but not communicate to the other.

25 The exchanged data includes device data such as identification, settings, status, time stamps, etc. The exchanged data may also include user inputs, patient physiologic parameters, electrotherapy, etc. The control data may include the ability of one device to control the state of the other; to recognize and interpret the inputs of the other for making decisions. In addition, there can be "analog" connection to therapy electrodes, ECG electrodes, or other sensors.

30 The handshake may be established with the one device as "master" and the other as "slave", or both as peers. A peer connection is not favored, since that might require a user to be operating two I/O modules. In addition, prompts in at

least one of the devices might assist the user in connecting the device to the other.

The determination of which one should be master is preferably made by comparing their relative capability to coordinate the devices. Such may start even wirelessly, as they are brought close to each other. An example is described below.

Fig. 19 is a view of a sample screen 500 of a defibrillator according to the invention, when it requests connection with an ECC device according to the invention. The device ID may be seen at 502. Remarks can be displayed at 504. The detection of a cooperating device is noted at 506. The coordination capability of the coordinating device is displayed at 508. A master-slave relationship is initiated at 510.

Fig. 20 is a view of a sample screen 520 of the ECC, when the request is received. The device ID may be seen at 522. Remarks are displayed at 524. The detection of a cooperating device is noted at 526. Receipt of request for a master-slave relationship is displayed at 528. The use is prompted for acceptance of the master-slave relationship at 530.

The device that is in control preferably takes over all input / output functionality. In addition, it takes control of operations of both devices under a single operation.

As the connection is established, compatibility is determined of the various functions, inputs, etc. An example is seen below.

Referring to Fig. 21, a screen 550 is shown of when compatibility is established at 558. The clocks are synchronized at 556. This may take place by coordinating the time stamps of the two devices, either by using a common clock, or by communication of events, or by denoting a difference between the times shown by the clocks of the devices. Various inputs are checked at 558, to see if they will be understood if received.

The present invention may be implemented by one or more devices that include logic circuitry. The device performs functions and/or methods as are described in this document. The logic circuitry may include a processor that may be programmable for a general purpose, or dedicated, such as microcontroller, a

microprocessor, a Digital Signal Processor (DSP), etc. For example, the device may be a digital computer like device, such as a general-purpose computer selectively activated or reconfigured by a computer program stored in the computer. Alternately, the device may be implemented as an Application Specific
5 Integrated Circuit (ASIC), etc. These features can be integrated with the invention, or coupled with it.

Moreover, the invention additionally provides methods, which are described below. The methods and algorithms presented herein are not necessarily inherently associated with any particular computer or other apparatus. Rather,
10 various general-purpose machines may be used with programs in accordance with the teachings herein, or it may prove more convenient to construct more specialized apparatus to perform the required method steps. The required structure for a variety of these machines will become apparent from this description.

15 In all cases there should be borne in mind the distinction between the method of the invention itself and the method of operating a computing machine. The present invention relates both to methods in general, and also to steps for operating a computer and for processing electrical or other physical signals to generate other desired physical signals.

20 The invention additionally provides programs, and methods of operation of the programs. A program is generally defined as a group of steps leading to a desired result, due to their nature and their sequence. A program made according to an embodiment of the invention is most advantageously implemented as a program for a computing machine, such as a general-purpose computer, a special
25 purpose computer, a microprocessor, etc.

The invention also provides storage media that, individually or in combination with others, have stored thereon instructions of a program made according to the invention. A storage medium according to the invention is a computer-readable medium, such as a memory, and is read by the computing
30 machine mentioned above.

The steps or instructions of a program made according to an embodiment of the invention requires physical manipulations of physical quantities. Usually,

though not necessarily, these quantities may be transferred, combined, compared, and otherwise manipulated or processed according to the instructions, and they may also be stored in a computer-readable medium. These quantities include, for example electrical, magnetic, and electromagnetic signals, and also states of matter that can be queried by such signals. It is convenient at times, principally for reasons of common usage, to refer to these quantities as bits, data bits, samples, values, symbols, characters, images, terms, numbers, or the like. It should be borne in mind, however, that all of these and similar terms are associated with the appropriate physical quantities, and that these terms are merely convenient labels applied to these physical quantities, individually or in groups.

Figure 22 illustrates a general computer, processor, or controller 440 having a data storage device or computer readable medium 446 interfaced with computer 440 to transfer data via link 448, or the data may define a program. Computer 440 of Figure 22 may be implemented by a CPU, and preferably interfaces with either one of the IO modules or human interface devices previously described. Computer or controller 440 includes a memory 442 containing executable logic or program 444.

This detailed description is presented largely in terms of flowcharts, display images, algorithms, and symbolic representations of operations of data bits within at least one computer readable medium, such as a memory. An economy is achieved in the present document in that a single set of flowcharts is used to describe both methods of the invention, and programs according to the invention. Indeed, such descriptions and representations are the type of convenient labels used by those skilled in programming and/or the data processing arts to effectively convey the substance of their work to others skilled in the art. A person skilled in the art of programming may use these descriptions to readily generate specific instructions for implementing a program according to the present invention.

Often, for the sake of convenience only, it is preferred to implement and describe a program as various interconnected distinct software modules or features, individually and collectively also known as software and softwares. This is not necessary, however, and there may be cases where modules are

equivalently aggregated into a single program with unclear boundaries. In any event, the software modules or features of the present invention may be implemented by themselves, or in combination with others. Even though it is said that the program may be stored in a computer-readable medium, it should be clear to a person skilled in the art that it need not be a single memory, or even a single machine. Various portions, modules or features of it may reside in separate memories, or even separate machines. The separate machines may be connected directly, or through a network, such as a local access network (LAN), or a global network, such as the Internet.

10 It will be appreciated that some of these methods may include software steps which may be performed by different modules of an overall parts of a software architecture. For example, data forwarding in a router may be performed in a data plane, which consults a local routing table. Collection of performance data may also be performed in a data plane. The performance data may be processed in a control plane, which accordingly may update the local routing table, in addition to neighboring ones. A person skilled in the art will discern which step is best performed in which plane.

In the present case, methods of the invention are implemented by machine operations. In other words, embodiments of programs of the invention are made such that they perform methods of the invention that are described in this document. These may be optionally performed in conjunction with one or more human operators performing some, but not all of them. As per the above, the users need not be collocated with each other, but each only with a machine that houses a portion of the program. Alternately, some of these machines may operate automatically, without users and/or independently from each other.

25 Methods of the invention are now described.

Referring now to Fig. 23, a flowchart 2000 is used to illustrate a method according to an embodiment of the invention. The method of flowchart 2000 may also be practiced by the devices of the invention described in this document.

30 Above and beyond the method described herein, the responder (who is also a user) may be instructed on how to apply a device, and or interactively give feedback, and/or to perform steps of the method, etc.

According to a box 2010, signals are received about the patient, and optionally are also monitored. Optionally, they are also recorded, displayed, transmitted, etc.

5 The signals are received from the patient (such as ECG), from special sensors (such as oximetry, impedance, force, pulse detection sensors, etc.). Signals may also be received from other components or devices (size of belt or vest around patient's chest, GPS signals, control signals from a device of a responder attending to the patient, etc.). Signals may further be received from the responder interactively, e.g. by asking questions and receiving answers.

10 The signals are then analyzed and treated as inputs, as is also shown in the rest of flowchart 2000. Analysis may be implemented also by taking advantage of the combined functionalities and features. For example, knowledge of the time profile of the chest compression is used to remove the chest compression artifact from the ECG.

15 The process of box 2010 preferably takes place continuously, even if execution moves also to other boxes of flowchart 2000. Monitoring is for the conditions that are applicable for the below, including, for example, for the effectiveness of chest compressions. There can be different stages of monitoring, such as main monitoring, at exact box 2010, and secondary monitoring concurrent
20 with other stages, e.g. at the same time as any one of boxes 2030, 2040, 2080 below.

In addition, monitoring may be also for detecting Acute Myocardial Infarction (AMI), via the ECG or other monitoring parameters, and indicating this to the caregiver. If AMI is detected, then monitoring may also be for cardiac arrest
25 (which commonly occurs during an AMI).

In addition to monitoring, preferably there is also recording. The accumulated record may include records of events, data monitored, and functionalities of the invention that are operating, and time profiles of their operation.

30 A number of decision trees may then be implemented, in determining what action to take next. The best embodiments known to the inventors are described, but that is only by way of example, and not of limitation. Further, the flowchart

may be integrated with other steps, such as administering medications (e.g. cardiac drugs), etc. But simplistically, the ECG input is analyzed for a shockable rhythm, and then either defibrillation takes place, or pulse or other signs of circulation are checked, following the same protocol as today's AEDs. Further, a user would be prompted to start the chest compression device and ventilations if there was no pulse (or no signs of circulation.) A more rigorous way is described below.

According to a next box 2020, it is determined whether Ventricular Fibrillation (VF) of the patient's heart is occurring. If so, then according to a next box 2030, the patient is defibrillated. This is accomplished by administering electrotherapy, such as a defibrillation shock. If a child ("pediatric") patient is sensed, then the defibrillation energy level may be adapted automatically (e.g. be set to 50J). Such sensing may be from responder inputs, the belt or vest size when tightened around the patient, etc.

In some embodiments of the invention, at box 2030, instead of delivering a defibrillation shock, the CPR portion is used to deliver a precordial thump to deliver the patient. In particular, when the device detects a shockable rhythm, rather than delivering an electrical defibrillation pulse, the device first deliver a precordial thump to the patient, via the chest compression device, to attempt defibrillation. This is a great advantage of the invention, in that it can revert from one form of therapy to another.

In yet other embodiments, based on the patient's downtime (which could be entered into the device by the caregiver), or by analysis of parameter that indicates probability of shock success (such as ECG), it may first be decided whether to deliver electrotherapy, or to first perform CPR, and/or to first deliver medications prior to defibrillating. That action could either be started automatically by the system, or could be started with manual action from the user.

Execution may then return to box 2010, where inputs are received and analyzed. In a preferred optional embodiment, however, according to a next box 2040, Cardiopulmonary Resuscitation (CPR) is either performed automatically, or instructed for the responder to perform, after defibrillating. Instruction may be by voice commands, and/or may include sounds for the responder to synchronize

their action. In addition, depending on the monitored inputs, the repetition rate of the CPR is adjusted. Further, if CPR is performed automatically, the force and its time profile are also adjusted. Execution returns to box 2010.

5 According to important alternate embodiments of the invention, boxes 2030 and 2040 take place together. In other words, defibrillation takes place while CPR is being performed automatically.

Referring briefly to Fig. 24, a time profile of the chest compressions is shown. More particularly, the changing circumference of the patient chest is plotted, as squeezed and released. In addition, the level of patient impedance is
10 plotted in dashed lines, following in pattern the time profile of the chest circumference. (Other impedance variations may be superimposed on the level of impedance). The profile of chest squeezing may be known directly, or indirectly from a monitored parameter such as the level of impedance.

Advantageously, defibrillation (the large lightning bolts in Fig. 24) may take
15 place any time in the CPR cycle. The exact timing is chosen in synchronization to pursue various optimizations. For example, if it is desired to exploit the smallest possible impedance, defibrillation happens according to bolt (A). On the other hand, if it is desired to exploit the moment that the heart is filled with the most blood (and thus draw the most current through the heart), then defibrillation
20 happens according to bolt (B).

CPR may continue after defibrillation, or even be halted after it. An advantage of the invention is that the waiting time from CPR to defibrillation is minimized. Pacing takes place as described later in this document.

Returning to Fig. 23, if, at box 2020 it is determined that the patient is not
25 undergoing VF, then according to an optional next box 2050, it is inquired whether a pulse is detected. If not, then according to an optional next box 2060, it is inquired whether the condition of Ventricular Tachycardia (VT) is detected. If so, then execution reverts to box 2030, and the patient is defibrillated. But if no VT is detected at box 2060, then execution reverts to box 2040 for performing CPR.

30 If a pulse is detected at box 2050, then, according to an optional next box 2070, it is inquired whether respiration is detected. If so, then execution returns to box 2010. Respiration may be detected automatically by respiration sensors,

such as a CO₂ (carbon dioxide) sensor, chest movement sensor, or an impedance sensor.

If at box 2070 there is no respiration detected, then according to an optional next box 2080, ventilation is performed automatically by a ventilator, or rescue breathing is instructed for the responder to perform. Execution returns to box 2010.

Since box 2010 is preferably executed continuously, the method also includes discontinuing one type of therapy, and optionally also starting another consistently with the above. Also, if one of the signs changes, execution may return to box 2010 and start over. For example, pulse may be lost while ventilating. Or the onset of respiration may be detected, in which case other activities (such as ventilation) stop.

Referring now to optional box 2090, optional pacing according to the invention is also described. In the embodiment of Fig 23, the condition for enabling pacing is examined in two circumstances, namely in transitioning from box 2050 to 2070, and also in transitioning from box 2060 to 2040.

Referring now to Fig. 25, box 2090 is described in more detail. In both cases, it is inquired whether severe bradycardia is detected. In addition, if no pulse has been detected, it is inquired whether ventricular asystole has been detected. If not, then execution continues as before (from box 2050 to 2070, and from box 2060 to 2040). If yes, then according to a box 2095, pacing is performed.

Returning to Fig. 24, pacing (shown as a small lightning bolt) may also be coordinated with the administration of CPR. Pacing is preferably synchronized with the compression cycle. There is some evidence that chest compressions may cause a QRS complex (ventricular depolarization), if the heart is able to support it. Accordingly, pacing during the compression cycle provides the additional impetus to the ventricles. Also, pacing should be avoided a few 100 msec after a QRS complex, during the ventricular vulnerability period.

At any one time during the method of Fig. 23, inputs are received (for monitoring) from the available sensors, from the user through the I/O module, and

from the interfaces during communication. Outputs are communicated to the user through the I/O module, sometimes through the interface during implementation.

Referring now to Fig. 26, a sample screen is shown for communicating to the user the outputs. In the example of Fig. 21, there is a count down for
5 imminent defibrillation (at the 3 sec point). The screen is preferably from the "master" device in the relationship. Some of the inputs are generated on board, while others are generated by the other device, and received by the interface.

A person skilled in the art will be able to practice the present invention in view of the description present in this document, which is to be taken as a whole.
10 Numerous details have been set forth in order to provide a more thorough understanding of the invention. In other instances, well-known features have not been described in detail in order not to obscure unnecessarily the invention.

While the invention has been disclosed in its preferred form, the specific embodiments as disclosed and illustrated herein are not to be considered in a
15 limiting sense. Indeed, it should be readily apparent to those skilled in the art in view of the present description that the invention may be modified in numerous ways. The inventors regard the subject matter of the invention to include all combinations and sub combinations of the various elements, features, functions and/or properties disclosed herein.

20

CLAIMS

1. A system comprising:
an external chest compression (ECC) device having a first communication
module; and
5 a defibrillator having a second communication module,
in which the ECC device and the defibrillator are capable of communicating
via the first communication module and the second communication module.
2. A system as in claim 1, in which the ECC device includes a backboard.
3. A system as in claim 2, further comprising wheels operably attached to the
10 backboard.
4. A system as in claim 2, in which the ECC device includes at least one chest
compression member operably coupled to the backboard.
5. A system as in claim 4, further comprising a chest pressure sensor.
6. A system as in claim 4, further comprising an electrode disposed on the
15 chest compression member.
7. A system as in claim 6, further comprising a second defibrillation electrode.
8. A system as in claim 6, further comprising multiple defibrillation electrodes coupled to
the chest compression member.
9. A system as in claim 6, further comprising multiple ECG electrodes coupled
20 to the chest compression member.
10. A system as in claim 6, in which the electrode includes a releasable
electrolyte.
11. A system as in claim 6, in which the electrode can be electrically coupled to
the defibrillator.
- 25 12. A system as in claim 4, in which the chest compression member includes a
belt.
13. A system as in claim 6, further comprising a powered belt retractor coupled
to the belt.
14. A system as in claim 4, in which the chest compression member includes a
30 rigid member pivotally coupled to the backboard.
15. A system as in claim 14, further comprising a powered actuator for driving
the chest compression rigid member.

16. A system as in claim 14, in which the chest compression rigid member is manually operable to effect ECC.
17. A system as in claim 1, in which the ECC device includes at least one
5 sensor for outputting data and sensing physiological data from the patient.
18. A system as in claim 17, in which the ECC device communication module is coupled to the at least one sensor.
19. A system as in claim 17, in which the physiological data includes at least
10 one attribute from the group consisting of pulse, heartbeat, breathing, body temperature, externally applied chest pressure and thoracic impedance,
20. A system as in claim 1, further comprising a first controller, in which the first controller is operably coupled to the ECC device.
21. A system as in claim 20, further comprising at least one sensor coupled to the first controller.
- 15 22. A system as in claim 20, further comprising a chest compression member and a powered chest compression actuator operably coupled to the chest compression member and operably coupled to the first controller.

Fig. 1

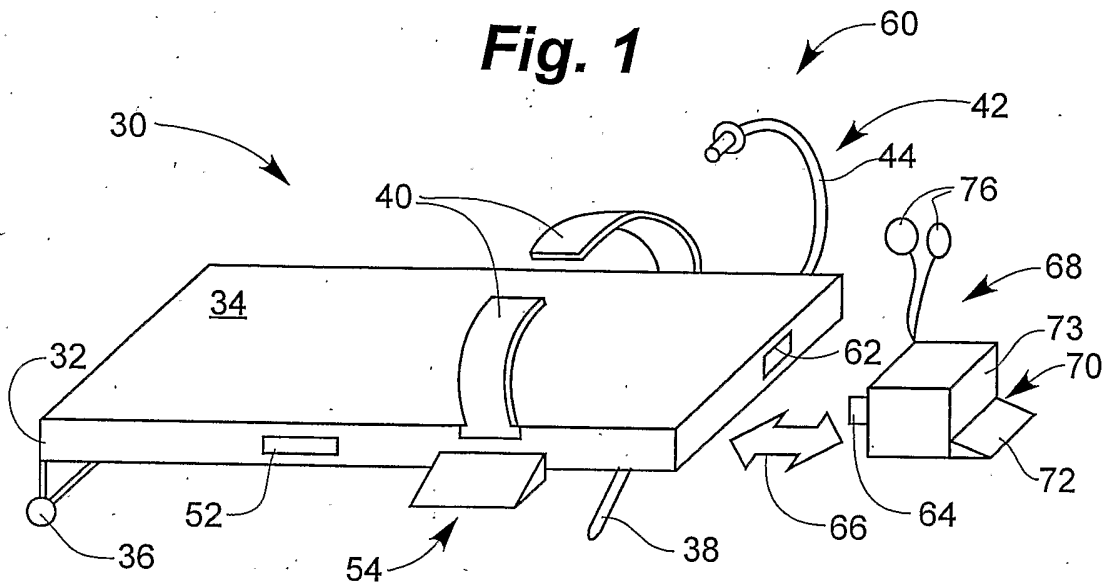

Fig. 2

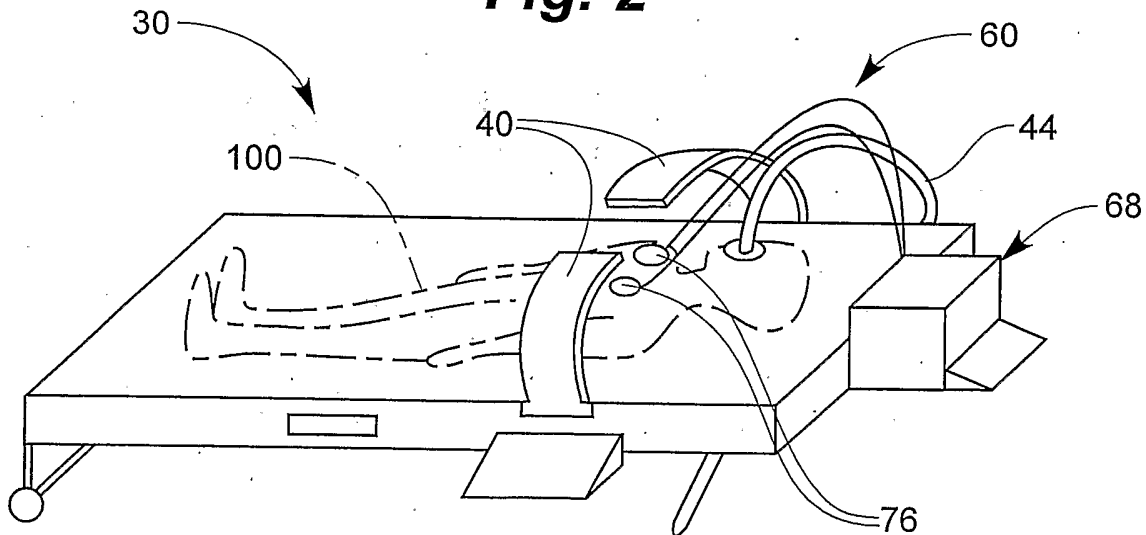

Fig. 3

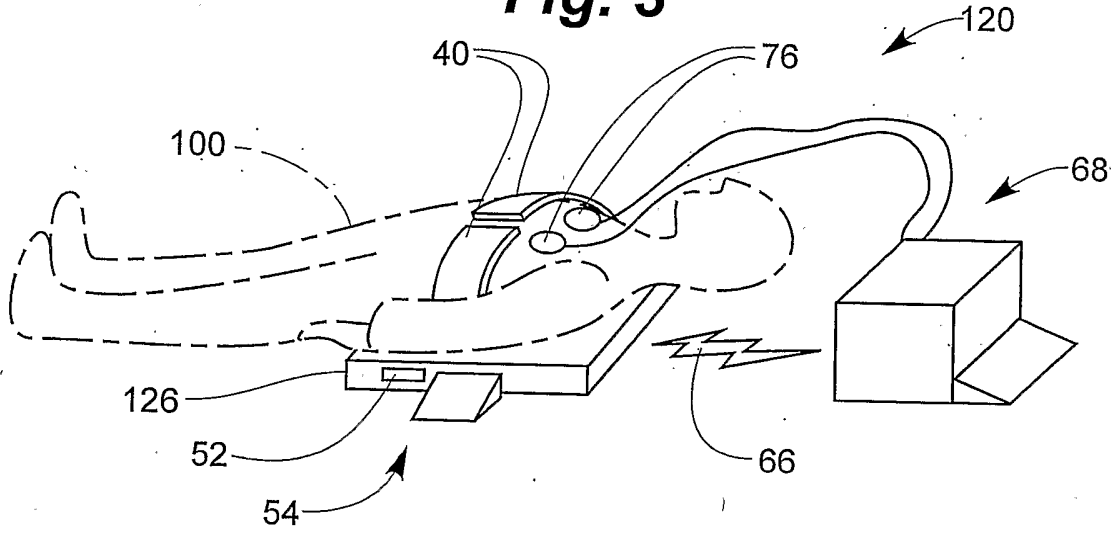

Fig. 4

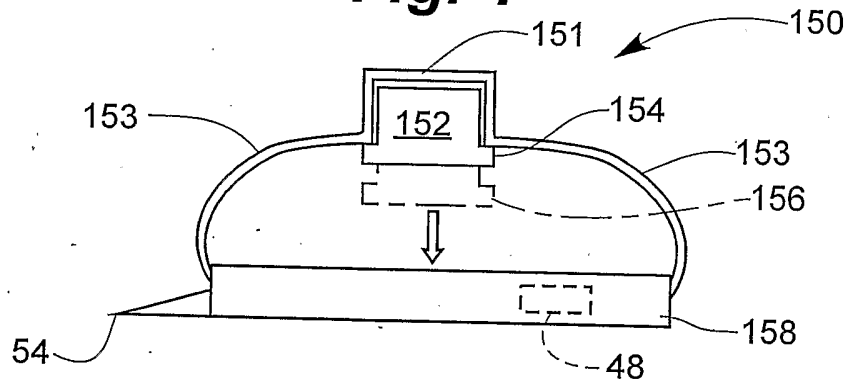

Fig. 5

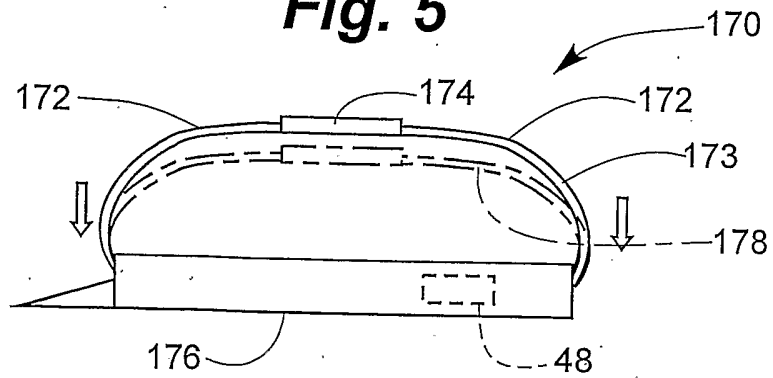

Fig. 6

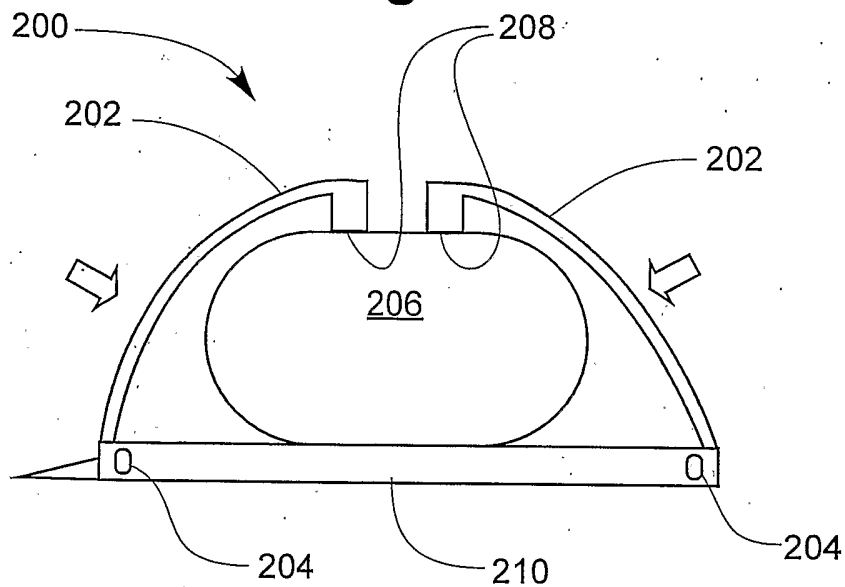

Fig. 7

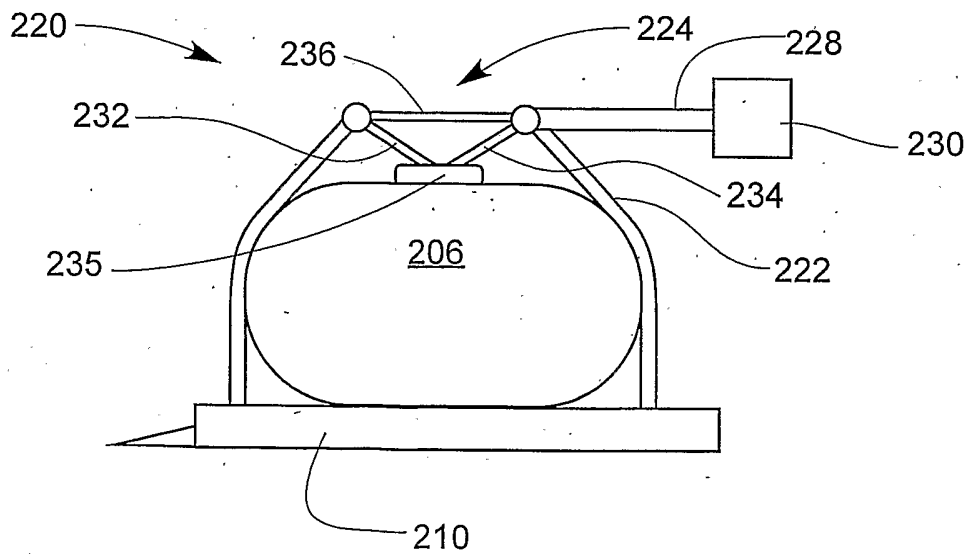

Fig. 8

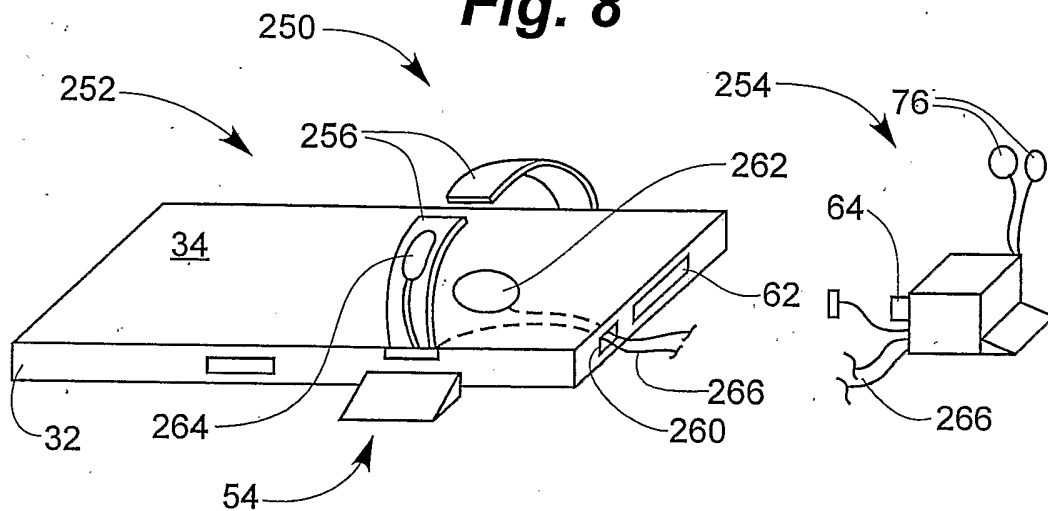

Fig. 9

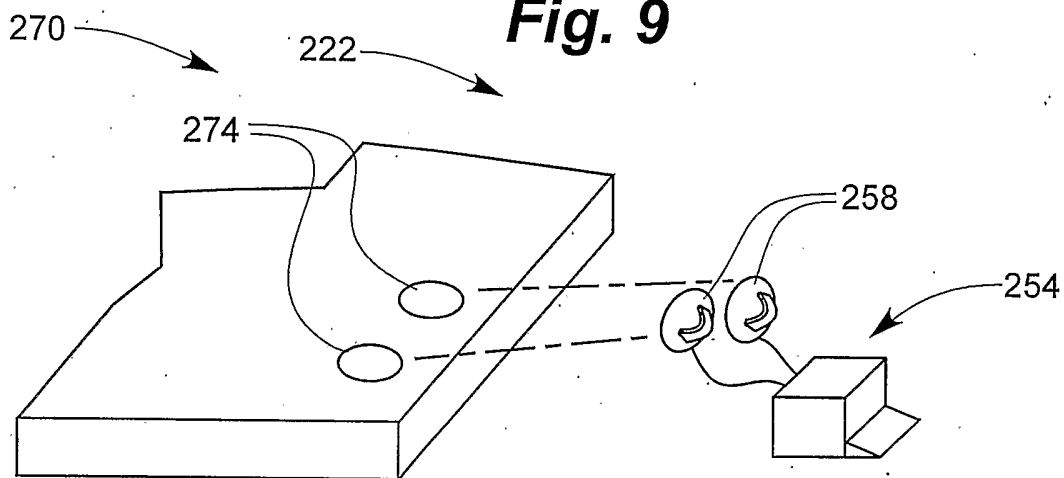

Fig. 10

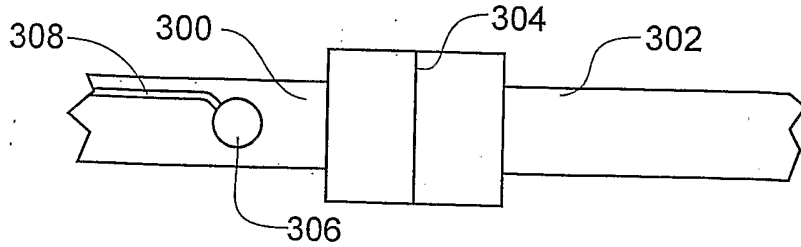

Fig. 11

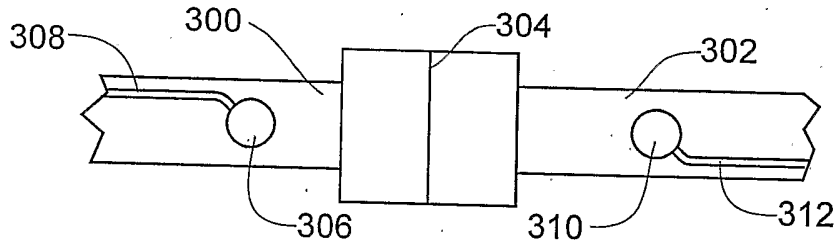

Fig. 12

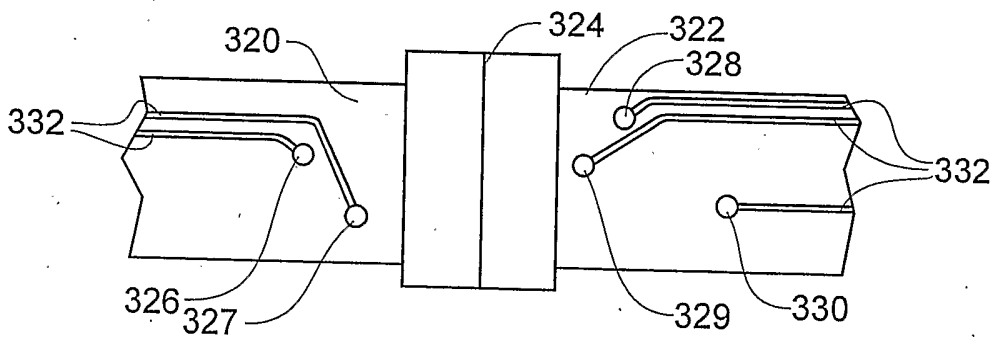

Fig. 13

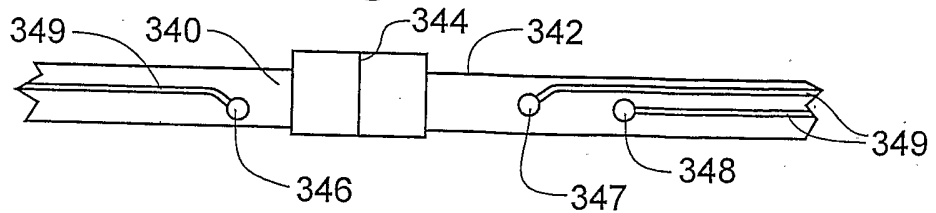

Fig. 14

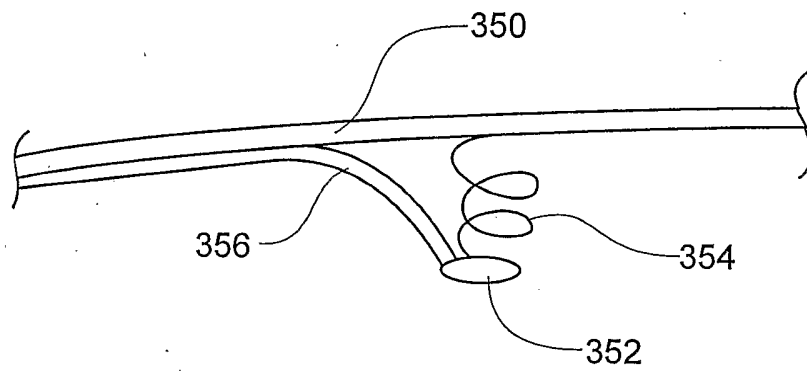

Fig. 15

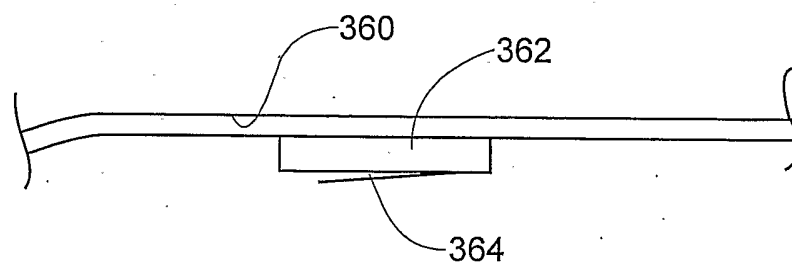

Fig. 16

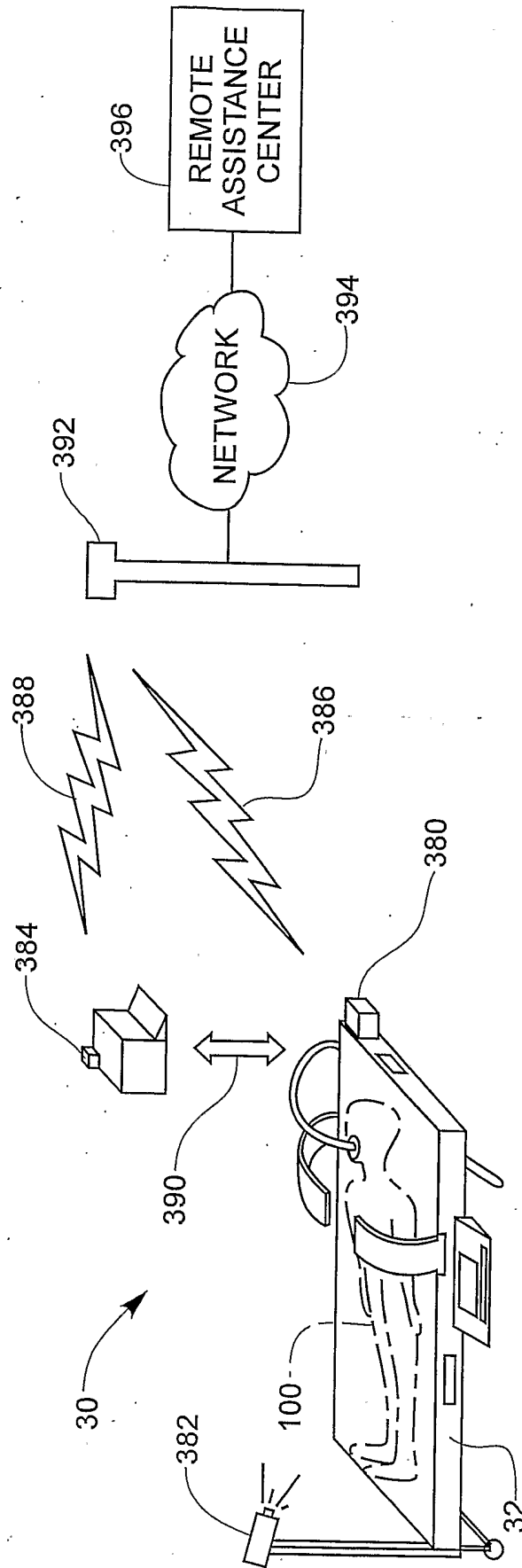

Fig. 17

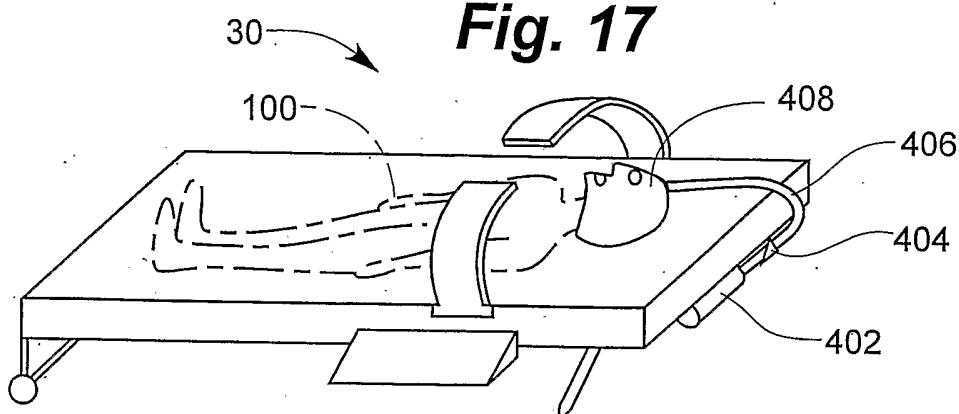

Fig. 18

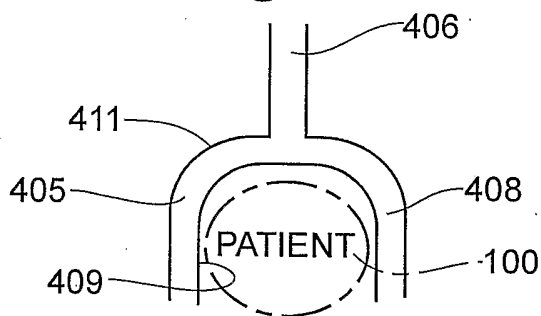

Fig. 19

504 THIS IS DEFIBRILLATOR MONITOR SER. NO. #XXXX 500
 REMARKS
 DETECTING OTHER DEVICE IN VICINITY
 COMPATIBILITY ... OK
 OTHER DEVICE IDENTIFIED AS:
 EXTERNAL CHEST COMPRESSION DEVICE SER. NO. YYYY
 COORDINATION CAPABILITY OF OTHER DEVICE ...LOWER
 REQUESTING COOPERATION, WITH OTHER DEVICE BEING:
 SLAVE PEER MASTER
 WAITING FOR RESPONSE.....

510

508

9/12

Fig. 20

524 THIS IS EXTERNAL CHEST COMPRESSION DEVICE SER. NO. YYYY 520

REMARKS 526

DETECTING OTHER DEVICE IN VICINITY. 522

COMPATIBILITY ... OK

RECEIVED REQUESTED FOR COOPERATION WHERE OTHER DEVICE IS

MASTER PEER SLAVE

APPROVE COOPERATION? YES NO 530

528

Fig. 21

556 THIS IS DEFIBRILLATOR MONITOR SER. NO. #XXXX 558

REMARKS 550

HANDSHAKE ... ESTABLISHED • COOPERATING WITH EXTERNAL

CHEST COMPRESSION DEVICE SER. NO. YYYY

CLOCKS ... SYNCHRONIZED

CHECKING COMPATIBILITY TO RECEIVE

12 LEAD ECG ... OK

CHEST SQUEEZING PROFILE (TIME, FORCE, DISPL.) ... OK

IMPEDANCE MEASUREMENT ... OK

TEMPERATURE MEASUREMENT ... REJECTED

PULSE DETECTION ... OK

RESPIRATION DETECTION ... OK

CAPNOGRAPHY (CO2) ... [WAITING]

Fig. 22

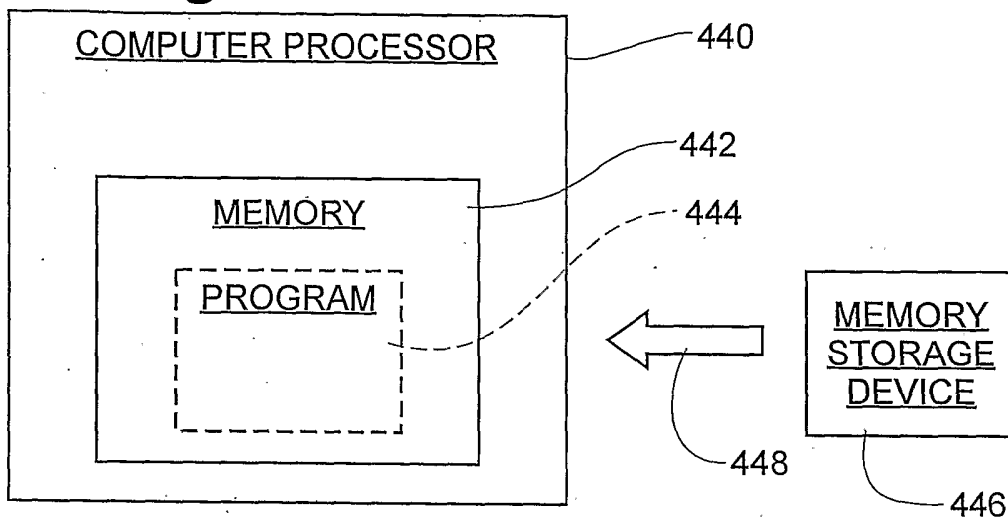

2000 **Fig. 23**

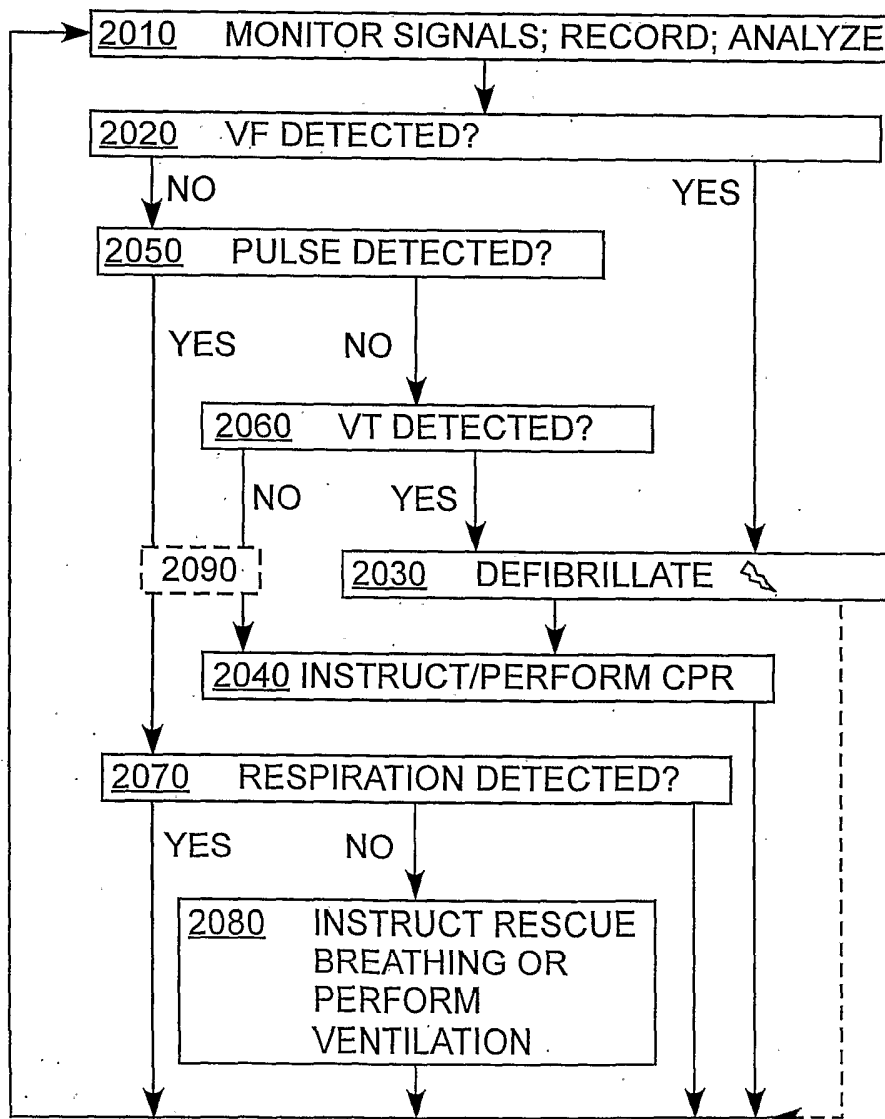

Fig. 24

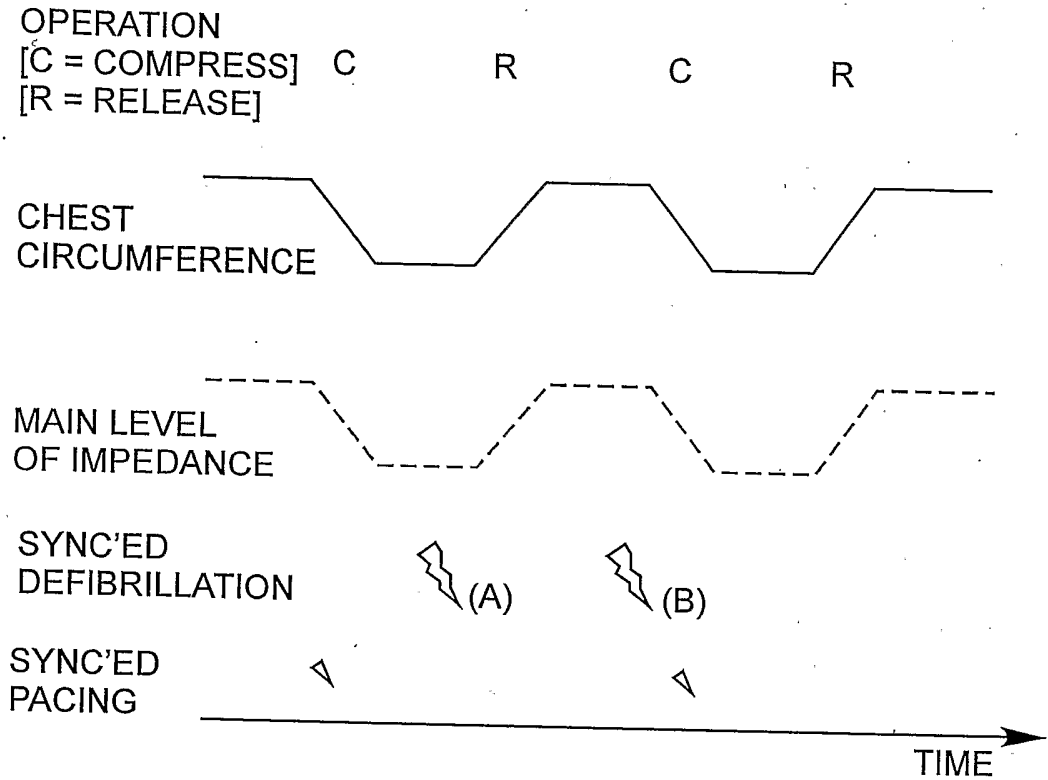
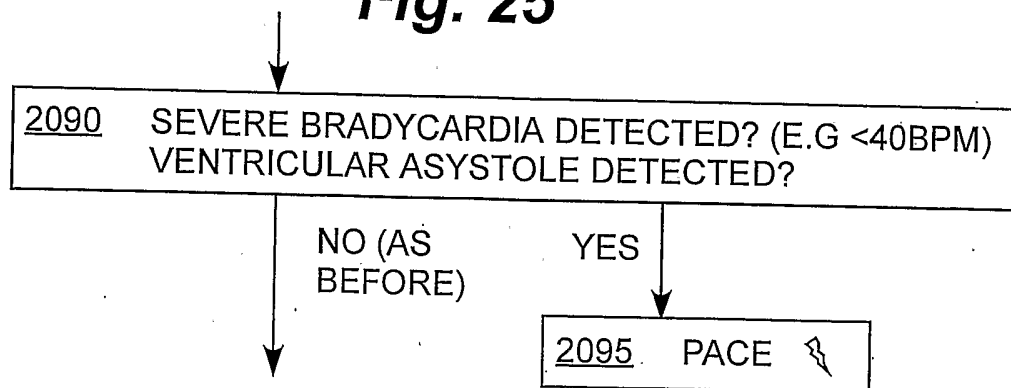
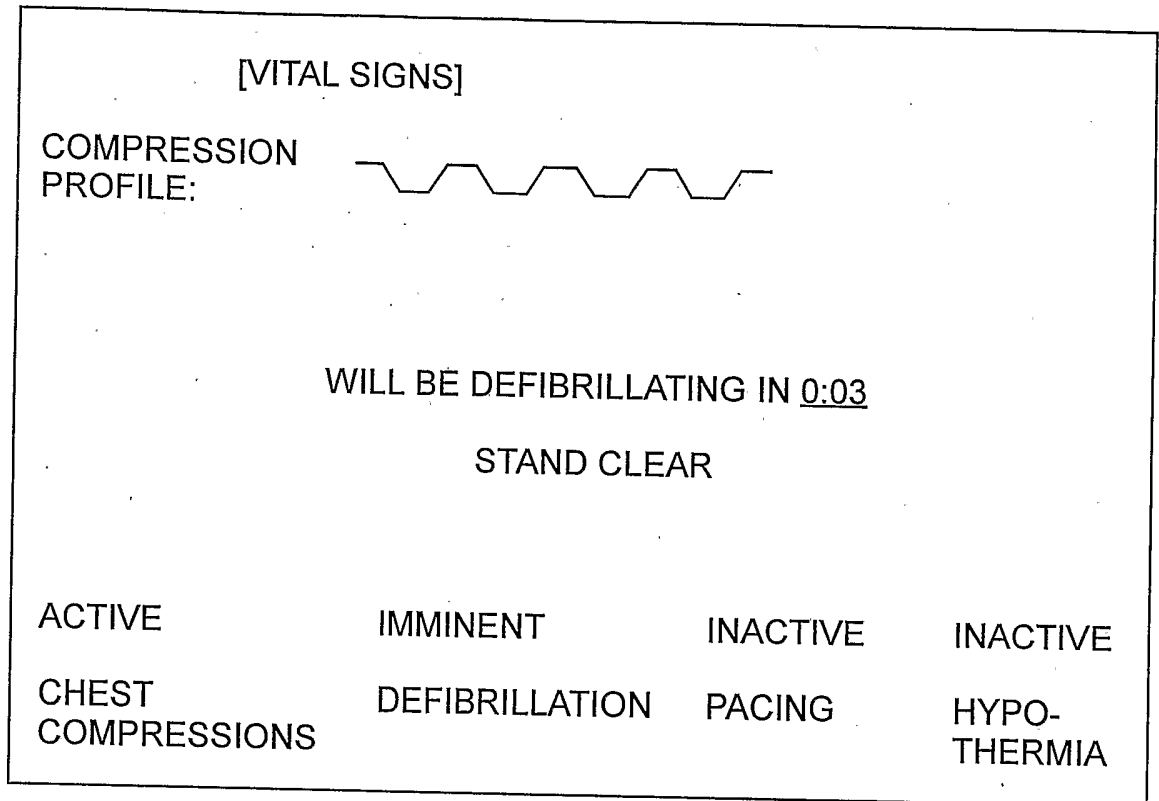

Fig. 25



12/12

Fig. 26



INTERNATIONAL SEARCH REPORT

International Application No
PCT/US2004/004097

A. CLASSIFICATION OF SUBJECT MATTER
IPC 7 A61H31/00 A61N1/39

According to International Patent Classification (IPC) or to both national classification and IPC

B. FIELDS SEARCHED

Minimum documentation searched (classification system followed by classification symbols)
IPC 7 A61H A61N

Documentation searched other than minimum documentation to the extent that such documents are included in the fields searched

Electronic data base consulted during the international search (name of data base and, where practical, search terms used)

EPO-Internal, WPI Data, PAJ

C. DOCUMENTS CONSIDERED TO BE RELEVANT

Category *	Citation of document, with indication, where appropriate, of the relevant passages	Relevant to claim No.
X	US 6 090 056 A (BYSTROM STEVEN R ET AL) 18 July 2000 (2000-07-18) column 4, line 3 - line 20 column 7, line 43 - column 8, line 9 column 8, line 54 - column 11, line 33; figures 1,2,7-9,11	1-22
X	US 2001/018562 A1 (BYSTROM STEVEN R ET AL) 30 August 2001 (2001-08-30) paragraphs '0014!', '0019!', '0027!', '0028!', '0031!', '0032!', '0037!; figure 1	1-22

Further documents are listed in the continuation of box C.

Patent family members are listed in annex.

* Special categories of cited documents :

- *A* document defining the general state of the art which is not considered to be of particular relevance
- *E* earlier document but published on or after the international filing date
- *L* document which may throw doubts on priority claim(s) or which is cited to establish the publication date of another citation or other special reason (as specified)
- *O* document referring to an oral disclosure, use, exhibition or other means
- *P* document published prior to the international filing date but later than the priority date claimed

- *T* later document published after the international filing date or priority date and not in conflict with the application but cited to understand the principle or theory underlying the invention
- *X* document of particular relevance; the claimed invention cannot be considered novel or cannot be considered to involve an inventive step when the document is taken alone
- *Y* document of particular relevance; the claimed invention cannot be considered to involve an inventive step when the document is combined with one or more other such documents, such combination being obvious to a person skilled in the art.
- *&* document member of the same patent family

Date of the actual completion of the international search

18 May 2004

Date of mailing of the international search report

28/05/2004

Name and mailing address of the ISA
European Patent Office, P.B. 5818 Patentlaan 2
NL - 2280 HV Rijswijk
Tel. (+31-70) 340-2040, Tx. 31 651 epo nl,
Fax: (+31-70) 340-3016

Authorized officer

Fischer, E

INTERNATIONAL SEARCH REPORT

International Application No
PCT/US2004/004097

C.(Continuation) DOCUMENTS CONSIDERED TO BE RELEVANT		
Category °	Citation of document, with indication, where appropriate, of the relevant passages	Relevant to claim No.
X	<p>US 4 273 114 A (BARKALOW CLARE E ET AL) 16 June 1981 (1981-06-16)</p> <p>column 3, line 14 - line 18 column 6, line 6 - line 14 column 6, line 66 -column 7, line 31 column 8, line 26 - line 45; figures 1,2,6-8</p> <p style="text-align: center;">----</p>	<p>1,2,4-9, 11,14, 15,17-22</p>
X	<p>US 5 490 820 A (SCHOCK ROBERT B ET AL) 13 February 1996 (1996-02-13) column 9, line 13 - line 20; figures 3,4,6,7</p> <p style="text-align: center;">----</p>	<p>1-4,6-9, 11,17-22</p>
A	<p>US 5 738 637 A (KELLY KEVIN A ET AL) 14 April 1998 (1998-04-14) column 4, line 54 - line 58 column 10, line 66 -column 11, line 9 column 12, line 1 - line 8 column 12, line 39 - line 48; claim 31; figures 1,10,12</p> <p style="text-align: center;">-----</p>	<p>2,4,5, 12-16</p>

INTERNATIONAL SEARCH REPORT

Information on patent family members

National Application No

PCT/US2004/004097

Patent document cited in search report		Publication date	Patent family member(s)	Publication date			
US 6090056	A	18-07-2000	AU 9032898	A 16-03-1999			
			BR 9811413	A 13-02-2002			
			CA 2301652	A1 04-03-1999			
			EP 1017351	A1 12-07-2000			
			JP 2001513399	T 04-09-2001			
			WO 9909929	A1 04-03-1999			
			US 6599258	B1 29-07-2003			
			US 2004073145	A1 15-04-2004			
			US 2001018562	A1	30-08-2001	US 6213960	B1 10-04-2001
US 2004039313	A1 26-02-2004						
AU 4677999	A 05-01-2000						
WO 9965560	A2 23-12-1999						
US 4273114	A	16-06-1981	US 4198963	A 22-04-1980			
			AT 2930	T 15-04-1983			
			CA 1133586	A1 12-10-1982			
			DE 2965148	D1 11-05-1983			
			EP 0010908	A1 14-05-1980			
			ES 485141	A1 16-05-1980			
			JP 1369400	C 25-03-1987			
			JP 55054965	A 22-04-1980			
			JP 61035871	B 15-08-1986			
			US 5490820	A	13-02-1996	AT 203891	T 15-08-2001
						AU 6364594	A 26-09-1994
DE 69427906	D1 13-09-2001						
DE 69427906	T2 04-04-2002						
DK 688201	T3 01-10-2001						
EP 0688201	A1 27-12-1995						
ES 2159555	T3 16-10-2001						
JP 3510254	B2 22-03-2004						
JP 8507459	T 13-08-1996						
WO 9420060	A1 15-09-1994						
US 5738637	A	14-04-1998				AU 726800	B2 23-11-2000
						AU 1123297	A 14-07-1997
			BG 102627	A 26-02-1999			
			BR 9612024	A 28-12-1999			
			CA 2240063	A1 26-06-1997			
			CN 1211174	A 17-03-1999			
			CZ 9801855	A3 14-07-1999			
			EP 0955986	A1 17-11-1999			
			HU 9902045	A2 29-11-1999			
			JP 2000501971	T 22-02-2000			
			NO 982690	A 11-08-1998			
			PL 327462	A1 07-12-1998			
			RO 116765	B1 29-06-2001			
			RU 2194488	C2 20-12-2002			
			SI 9620127	A 31-12-1998			
			TR 9801101	T2 21-09-1998			
			TW 450804	B 21-08-2001			
			US 6234984	B1 22-05-2001			
			WO 9722327	A1 26-06-1997			
			US 6325771	B1 04-12-2001			
			US 2004030272	A1 12-02-2004			
US 2002002347	A1 03-01-2002						