



- (51) International Patent Classification:
A61F 2/44 (2006.01)
- (21) International Application Number:
PCT/US2014/030358
- (22) International Filing Date:
17 March 2014 (17.03.2014)
- (25) Filing Language: English
- (26) Publication Language: English
- (30) Priority Data:
61/801,666 15 March 2013 (15.03.2013) US
- (71) Applicant: 4-WEB, INC. [US/US]; Hunt, Jesse, 6170 Research Rd., Suite 219, Frisco, Texas 75033 (US).
- (72) Inventors: HUNT, Jesse; 6629 Whispering Woods Court, Plano, Texas 75024 (US). GANEY, Timothy; 6170 Research Rd., Suite 219, Frisco, Texas 75033 (US).
- (74) Agent: MEYERTONS, Eric B.; Meyertons, Hood, Kivlin, Kowert & Goetzel, P.C., P.O. Box 398, Austin, Texas 78767-0398 (US).
- (81) Designated States (unless otherwise indicated, for every kind of national protection available): AE, AG, AL, AM, AO, AT, AU, AZ, BA, BB, BG, BH, BN, BR, BW, BY,

BZ, CA, CH, CL, CN, CO, CR, CU, CZ, DE, DK, DM, DO, DZ, EC, EE, EG, ES, FI, GB, GD, GE, GH, GM, GT, HN, HR, HU, ID, IL, IN, IR, IS, JP, KE, KG, KN, KP, KR, KZ, LA, LC, LK, LR, LS, LT, LU, LY, MA, MD, ME, MG, MK, MN, MW, MX, MY, MZ, NA, NG, NI, NO, NZ, OM, PA, PE, PG, PH, PL, PT, QA, RO, RS, RU, RW, SA, SC, SD, SE, SG, SK, SL, SM, ST, SV, SY, TH, TJ, TM, TN, TR, TT, TZ, UA, UG, US, UZ, VC, VN, ZA, ZM, ZW.

(84) Designated States (unless otherwise indicated, for every kind of regional protection available): ARIPO (BW, GH, GM, KE, LR, LS, MW, MZ, NA, RW, SD, SL, SZ, TZ, UG, ZM, ZW), Eurasian (AM, AZ, BY, KG, KZ, RU, TJ, TM), European (AL, AT, BE, BG, CH, CY, CZ, DE, DK, EE, ES, FI, FR, GB, GR, HR, HU, IE, IS, IT, LT, LU, LV, MC, MK, MT, NL, NO, PL, PT, RO, RS, SE, SI, SK, SM, TR), OAPI (BF, BJ, CF, CG, CI, CM, GA, GN, GQ, GW, KM, ML, MR, NE, SN, TD, TG).

Published:

- with international search report (Art. 21(3))
- before the expiration of the time limit for amending the claims and to be republished in the event of receipt of amendments (Rule 48.2(h))

(54) Title: MOTION PRESERVATION IMPLANT AND METHODS

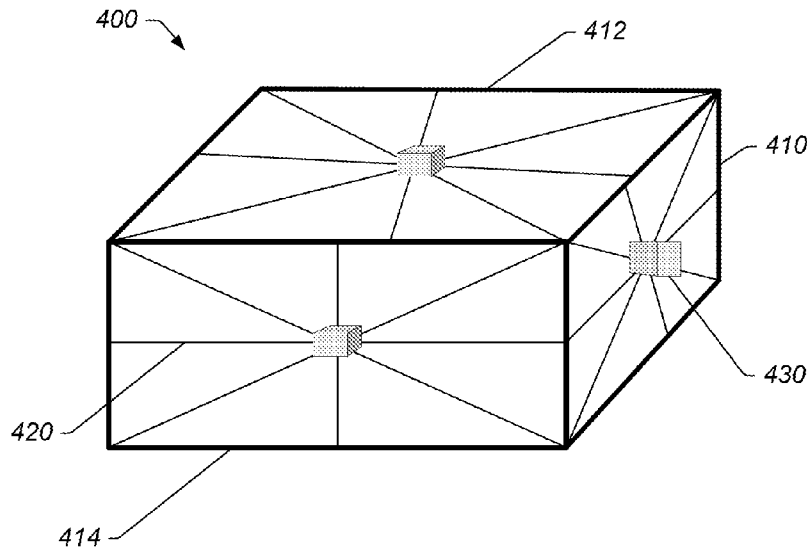

FIG. 10

(57) Abstract: Various embodiments of implant systems and related apparatus, and methods of operating the same are described herein. In various embodiments, an implant for interfacing with a bone structure includes a web structure, including a space truss, configured to interface with human bone tissue. The space truss includes two or more planar truss units having a plurality of struts joined at nodes. Implants include one or more flexible struts that impart flexibility to the implant.

WO 2014/145567 A1

TITLE: MOTION PRESERVATION IMPLANT AND METHODS

BACKGROUND OF THE INVENTION

5 1. Field of the Invention

[0001] The present invention relates generally to medical devices and, more specifically, to implants.

2. Description of the Relevant Art

[0002] Implants may be used in human and/or animals to support and/or secure one or more
10 bones. For example, implants may be used in the spine to support and/or replace damaged tissue
between the vertebrae in the spine. Once implanted between two vertebrae, the implant may
provide support between the two vertebrae and bone growth may take place around and through
the implant to at least partially fuse the two vertebrae for long-term support. Implants may
include relatively large rims with solid material that may cover, for example, 50% of the area that
15 interacts with the endplate. The rim may provide a contact area between the implant and the
vertebral endplates. Large rims may have several drawbacks. For example, large rims may
impede bone growth and reduce the size of the bone column fusing the superior and inferior
vertebral bodies.

[0003] Spinal implants may include open channels through the center of the supporting rims in a
20 superior/inferior direction. The open channel design may require members of the implant that
separate the rims that interact with the vertebral endplates to absorb the compressive forces
between the vertebral endplates. This may increase the pressure on smaller areas of the vertebral
endplates and may potentially lead to stress risers in the vertebral endplates. Further, while bone
graft material is often used in conjunction with implants to encourage bone growth, the open
25 column design of implants may reduce the likelihood of bone graft material from securing itself
to the implant that is not conducive to promoting good fusion.

[0004] Bone graft material may be packed into the implant in a high-pressure state to prevent
bone graft material from exiting the implant while being placed between the vertebral endplates.
The high-pressure state may also reduce the potential for the bone graft material loosening due to
30 motion between the implant and the vertebral endplates or compressive forces experienced
during settling of the implant. In addition, a high-pressure environment may allow the bone graft
material to re-model and fuse at greater strength. High-pressure states, however, may be difficult
to create and maintain for the bone graft material in an implant.

SUMMARY OF THE INVENTION

[0005] Various embodiments of implant systems and related apparatus, and methods of operating the same are described herein. In various embodiments, an implant for interfacing with a bone structure includes a web structure, including a space truss, configured to interface with human bone tissue including cells, matrix, mechanical forces, and ionic milieu. The space truss includes two or more planar truss units having a plurality of struts joined at nodes.

[0006] In an embodiment, an implant for interfacing with a bone structure, includes: a web structure that includes a plurality of struts joined at nodes, wherein the web structure is configured to interface with human bone tissue. The implant may include one or more of the struts are composed of an elastic material. In another embodiment, one or more struts may be formed from a viscoelastic material. The one or more elastic or viscoelastic struts may be placed in positions that allow the implant to flex during use. In some embodiments, all struts of the implant are composed of an elastic or viscoelastic material. A material that may be used to form at least some or all of the struts of an implant includes nickel-titanium alloys (e.g., nitinol).

[0007] In an embodiment, the first portion of struts that comprise the space truss may have: a deformation strength; a defined length; a diameter; a differential diameter along its length; a density; a porosity; or any combination of these physical properties; that is different from the second portion of the struts that comprise the space truss. In an embodiment, the space truss includes one or more central struts extending from the first bone contact surface to the second bone contact surface, wherein the central struts have a deformation strength that is greater than or less than the surrounding struts. In an embodiment, the space truss comprises one or more longitudinal struts extending parallel to the first bone contact surface and/or the second bone contact surface, wherein the longitudinal struts have a deformation strength that is greater than or less than the surrounding struts. The diameter of the first portion of the struts may be greater than a diameter of the second portion of the struts. The material used to form the first portion of struts may be different from the material used to form the second portion of struts.

BRIEF DESCRIPTION OF THE DRAWINGS

[0008] Advantages of the present invention will become apparent to those skilled in the art with the benefit of the following detailed description of embodiments and upon reference to the accompanying drawings in which:

[0009] FIGS. 1A-1B illustrate views of an implant with lordosis, according to an embodiment;

[0010] FIGS. 2A-2D illustrate views of an implant without lordosis, according to an embodiment;

[0011] FIGS. 3A-3B illustrate a web structure formed with triangular-shaped building blocks, according to an embodiment;

[0012] FIGS. 4A-4B illustrate a top structure of an internal web structure of the implant, according to an embodiment;

5 [0013] FIGS. 5A-5C illustrate progressive sectioned views of the implant showing the internal structure of the implant, according to an embodiment;

[0014] FIG. 5D illustrates an isometric view of the implant, according to an embodiment;

[0015] FIGS. 6A-6D illustrate another configuration of the web structure, according to an embodiment;

10 [0016] FIG. 7 illustrates a random web structure, according to an embodiment;

[0017] FIG. 8 illustrates a flowchart of a method for making an implant, according to an embodiment;

[0018] FIG. 9 illustrates a flowchart of a method for implanting a spinal implant, according to an embodiment;

15 [0019] FIG. 10 depicts an implant that includes a frame or support and a plurality of cables coupling different portions of the support; and

[0020] FIG. 11 depicts a strut having different diameters.

[0021] While the invention is susceptible to various modifications and alternative forms, specific embodiments thereof are shown by way of example in the drawings and will herein be described
20 in detail. It should be understood, however, that the drawings and detailed description thereto are not intended to limit the invention to the particular form disclosed, but on the contrary, the intention is to cover all modifications, equivalents, and alternatives falling within the spirit and scope of the present invention as defined by the appended claims.

DETAILED DESCRIPTION OF THE PREFERRED EMBODIMENTS

25 [0022] FIGS. 1A-1B illustrate views of implant **100**, according to an embodiment. The specifically depicted implant **100** may be used, for example, in anterior lumbar inter-body fusion (ALIF) or posterior lumbar inter-body fusion (PLIF), however, it should be understood that implant **100** may have a variety of shapes suitable for bone fusion applications. In some
30 embodiments, implant **100** may include a web structure with one or more trusses **102** (e.g., planar and space trusses). Implant **100** may be used in various types of implants for humans or animals such as spinal implants, corpectomy devices, knee replacements, hip replacements, long bone reconstruction scaffolding, and cranio-maxifacial implants, foot and ankle, hand and wrist, shoulder and elbow (large joint, small joint, extremity as well as custom trauma implants). Other implant uses are also contemplated.

[0023] As used herein a “truss structure” is a structure having one or more elongate struts connected at joints referred to as nodes. Trusses may include variants of a pratt truss, king post truss, queen post truss, town’s lattice truss, planar truss, space truss, and/or a vierendeel truss (other trusses may also be used). A “truss unit” is a structure having a perimeter defined by three or more elongate struts.”

[0024] As used herein a “planar truss” is a truss structure where all of the struts and nodes lie substantially within a single two-dimensional plane. A planar truss, for example, may include one or more “truss units” where each of the struts is a substantially straight member such that the entirety of the struts and the nodes of the one or more truss units lie in substantially the same plane. A truss unit where each of the struts is a substantially straight strut and the entirety of the struts and the nodes of the truss unit lie in substantially the same plane is referred to as a “planar truss unit.”

[0025] As used herein a “space truss” is a truss having struts and nodes that are not substantially confined in a single two-dimensional plane. A space truss may include two or more planar trusses (e.g., planar truss units) wherein at least one of the two or more planar trusses lies in a plane that is not substantially parallel to a plane of at least one or more of the other two or more planar trusses. A space truss, for example, may include two planar truss units adjacent to one another (e.g., sharing a common strut) wherein each of the planar truss units lie in separate planes that are angled with respect to one another (e.g., not parallel to one another).

[0026] As used herein a “triangular truss” is a structure having one or more triangular units that are formed by three straight struts connected at joints referred to as nodes. For example, a triangular truss may include three straight elongate strut members that are coupled to one another at three nodes to form a triangular shaped truss. As used herein a “planar triangular truss” is a triangular truss structure where all of the struts and nodes lie substantially within a single two-dimensional plane. Each triangular unit may be referred to as a “triangular truss unit.” A triangular truss unit where each of the struts is a substantially straight member such that the entirety of the struts and the nodes of the triangular truss units lie in substantially the same plane is referred to as a “planar triangular truss unit.” As used herein a “triangular space truss” is a space truss including one or more triangular truss units.

[0027] In various embodiments, the trusses **102** of the web structure may include one or more planar truss units (e.g., planar triangular truss units) constructed with straight or curved/arched members (e.g., struts) connected at various nodes. In some embodiments, the trusses **102** may be micro-trusses. A “micro-truss” is a truss having dimensions sufficiently small enough such that a plurality of micro-trusses can be assembled or other wise coupled to one another to form a web

structure having a small enough overall dimension (e.g., height, length and width) such that substantially all of the web structure can be inserted into an implant location (e.g., between two vertebra). Such a web structure and its micro-trusses can thus be employed to receive and distribute throughout the web structure loading forces of the surrounding tissue (e.g., vertebra, bone, or the like). In one embodiment, the diameters of the struts forming the micro-truss may be
5 between about 0.25 millimeters (mm) and 5mm in diameter (e.g., a diameter of about 0.25mm, 0.5 mm, 0.6 mm, 0.7 mm, 0.8 mm, 0.9 mm, 1 mm, 2 mm, 3 mm, 4 mm, or 5 mm). In one embodiment, a micro-truss may have an overall length or width of less than about 3mm.

[0028] As depicted, for example, in FIGS. 1A-1B, the web structure may extend throughout
10 implant **100** (including the central portion of implant **100**) to provide support throughout implant **100**. Trusses **102** of implant **100** may thus support implant **100** against tensile, compressive, and shear forces. Web structure may also reinforce implant **100** along multiple planes. The external truss structure may, for example, provide support against tensile and compressive forces acting vertically through the implant, and the internal web structure may provide support against tensile,
15 compressive, and shear forces along the various planes containing the respective trusses. In some embodiments, the web structure includes trusses **102** that form a triangulated web structure with multiple struts (e.g., struts 103a-f) (struts are generally referred to herein as “struts 103”).

[0029] In one embodiment, web structure of the implant **100** may include an internal web structure that is at least partially enclosed by an external truss structure. For example, in one
20 embodiment, web structure **101** may include an internal web structure that includes a space truss having at least a portion of the space truss surrounded by an external truss structure that includes one or more planar trusses formed with a plurality of planar truss units that lie substantially in a single plane. FIG. 1A depicts an embodiment of implant **100** having an internal web structure **104** and an external truss structure **105**. In the illustrated embodiment, internal web structure **104**
25 includes a space truss defined by a plurality of planar truss units **106** coupled at an angle with respect to one another such that each adjacent truss unit is not co-planar with each adjacent truss units. Adjacent truss units may include two truss units that share a strut and the respective two nodes at the ends of the shared strut.

[0030] In one embodiment, external truss structure **105** includes a plurality of planar trusses that
30 are coupled about an exterior, interior or other portion of the implant. For example, in the illustrated embodiment, the external truss structure **105** includes a series of planar trusses **107a,b** that are coupled to one another. Planar truss **107a** is denoted by a dashed line [- - - -], planar truss **107b** is denoted by dotted-dashed line [- · · · -]. Each planar truss is formed from a plurality of planar truss units (e.g., triangular planar truss units. As depicted, planar truss **107a** includes

four triangular planar truss units **108a,b,c,d** having a common vertex **110** and arranged to form a generally rectangular structure that lies in a single common plane. In other words, the four triangular planar truss units are arranged to form a substantially rectangular structure having “X” shaped struts extend from one corner of the rectangular structure to the opposite corner of the rectangular structure. As depicted, the substantially rectangular structure may include a trapezoidal shape. As described in more detail below, the trapezoidal shape may be conducive to providing an implant including lordosis. Lordosis may include an angled orientation of surfaces (e.g., top and bottom) of an implant that provides for differences in thickness in anterior and posterior regions of the implant such that the implant is conducive for supporting the curvature of a vertebral column.

[0031] In one embodiment, the planar trusses that form the external truss are coupled to one another, and are aligned along at least one axis. For example, in FIG. 1A, planar truss section **107a** is coupled to an adjacent planar truss **107b**. Planer truss sections **107a,b** are not parallel in all directions. Planar truss sections **107a,b** are, however, arranged parallel to one another in at least one direction (e.g., the vertical direction between the top and the bottom faces of implant **100**). For example, planar trusses **107a,b** and the additional planar trusses are arranged in series with an angle relative to one another to form a generally circular or polygon shaped enclosure having substantially vertical walls defined by the planar trusses and the planar truss units arranged in the vertical direction.

[0032] In one embodiment, the external truss portion may encompass the sides, top, and/or bottom of the implant. For example, in one embodiment, the external truss portion may include a top region, side regions, and/or a bottom region. FIG. 1A depicts an embodiment of implant **100** wherein external truss portion **105** includes a top **111**, bottom **112** and a side region **113**. As described above, side region **113** includes a series of planar trusses arranged vertically to form a circular/polygon ring-like structure that completely or at least partially surrounds the perimeter of the space truss disposed in the central portion of implant **100**. In the depicted embodiment, top portion **111** of external truss structure **105** includes a plurality of truss units coupled to one another to form a planar truss that cover substantially all of the top region of internal web structure **104**. In the illustrated embodiment, the top portion **111** spans entirely the region between top edges of the side portion **113** of external truss structure **105**. In the illustrated embodiment, top portion **111** is formed from a single planar truss that includes a plurality of truss units that lie in substantially the same plane. In other words, the planar truss of top portion **111** defines a generally flat surface. Although difficult to view in FIG. 1, the underside of implant **100** may include the bottom portion **112** having a configuration similar to that of the top portion

111. In other embodiments, external truss structure **105** may include a partial side, top and/or bottom external truss portions. Or may not include one or more of the side, top and bottom external truss portions. For example, as described in more detail below, FIG. 2C depicts an embodiment of implant **100** that includes an internal web structure formed from space trusses, that does not have an external truss structure.

[0033] In some embodiments, implant **100** may be formed from a biocompatible material such as a titanium alloy (e.g., γ Titanium Aluminides), cobalt, chromium, stainless steel, Polyetheretherketone (PEEK), Polyetherketoneketone (PEKK), ceramics, cements, etc. Other materials are also contemplated. In some embodiments, implant **100** may be made through a rapid prototyping process (e.g., electron beam melting (EBM) process) as further described below. Other processes are also possible (e.g., injection molding, casting, sintering, selective laser sintering (SLS), Direct Metal Laser Sintering (DMLS), etc). SLS may include laser-sintering of high-performance polymers such as that provided by EOS of North America, Inc., headquartered in Novi, Michigan, U.S.A. High-performance polymers may include various forms of PEEK (e.g., HP3 having a tensile strength of up to about 95 mega Pascal (MPa) and a Young's modulus of up to about 4400 MPa and continuous operating temperature between about 180 °C (356 °F) and 260 °C (500 °F)). Other materials may include PA 12 and PA 11 provided by EOS of North America, Inc.

[0034] As described above, in some embodiments the web structure may be formed from a plurality of triangular planar truss units. In some embodiments, the planar truss units may be coupled to each other to define polyhedrons that define the internal web structure. Examples of polyhedron structures that may be created by joining planar truss units include, but are not limited to, tetrahedrons, pentahedrons, hexahedrons, heptahedrons, pyramids, octahedrons, dodecahedrons, icosahedrons, and spherical fullerenes. In some embodiments, such as those described above, the space truss of the web structure may connect multiple midpoints of tetrahedron building blocks and include a regular pattern of tetrahedron blocks arranged adjacent one another. In some embodiments, the web structure may not include a pattern of geometrical building blocks. For example, FIG. 7 illustrates an irregular pattern of struts that may be used in an implant **905**. Other web structures are also contemplated. Examples of implants composed of a web structure are described in U.S. Published Patent Applications Nos.: 2010/0161061; 2011/0196495; 20110313532; and 2013/0030529, each of which is incorporated herein by reference.

[0035] FIGS. 3A-3B illustrate a schematic view of a portion of an internal web structure formed with space units formed from triangular planar truss units. Triangular planar truss units may be

joined together to form tetrahedrons **300a,b** that may also be used as building blocks (other patterns from the triangles are also contemplated). Other building blocks are also contemplated (e.g., square-shaped building blocks). In some embodiments, a web structure may include a single tetrahedron, such as tetrahedron **300a** or **300b** alone or in combination with one or more
5 other polyhedron. In some embodiments, a web structure may include two or more tetrahedrons **300a,b**. Tetrahedron **300a** may include four triangular faces in which three of the four triangles meet at each vertex. In some embodiments, two tetrahedrons **300a** and **300b** may be placed together at two adjacent faces to form space truss **313** with a hexahedron-shaped frame (including six faces). Hexahedron-shaped space truss **313** may include first vertex **301**, second
10 vertex **309**, third vertex **303**, fourth vertex **305**, and fifth vertex **307**. Common plane **311** may be shared by two tetrahedrons (e.g., common plane **311** may include third vertex **303**, fourth vertex **305**, and fifth vertex **307**) to form a hexahedron with first vertex **301** and second vertex **309** spaced away from common plane **311**. As depicted, the center portion of the triangular shaped building blocks may have a void region in their center that does not include any additional
15 members (e.g., no members other than the struts forming the triangular shaped building blocks) extending there through.

[0036] As seen in FIG. 3B, in some embodiments, multiple hexahedron-shaped space trusses **313** may be arranged in a side-by-side manner. Two space trusses **313** of implant **100** may be connected via their first vertices **301a,b** through strut **103r** and connected via their second
20 vertices **309a,b** through strut **103t**. Similarly, two space trusses **313** may be connected via their first vertices **301c,d** through strut **103p** and connected via their second vertices **309c,d** through strut **103s**. Other connections are also possible. For example, space trusses **313** may connect directly through side vertices (e.g., directly through corresponding vertices (such as vertices **303a,b**) and/or share a common strut (such as strut **103u**) and/or through a side face (e.g., side
25 faces **111a,b**).

[0037] FIG. 4A illustrates additional struts **103** (e.g., struts **103p** and **103r**) connecting the first vertices (represented respectively by **301a**, **301b**, **301c**, and **301d**) of four hexahedron-shaped space trusses in implant **100**. FIG. 4B illustrates additional struts **103** (e.g., struts **103s** and **103t**) connecting second vertices **309** (represented respectively by **309a**, **309b**, **309c**, and **309d**) of four
30 hexahedron-shaped space trusses in implant **100**. In some embodiments, additional struts **103** may also be used internally between one or more vertices of the web structures to form additional trusses (e.g., see web structures in FIGS. 1A-2B) (other structures are also possible).

[0038] As shown in FIG. 1A, top surface **115a** and bottom surface **115b** of implant **100** may include triangles, squares, circles or other shapes (e.g., a random or custom design). Top and

bottom surfaces **115a,b** may be used to connect the top and bottom vertices of various geometrical building blocks used in the web structure of implant **100**. For example, each vertex may be connected through struts to the neighboring vertices of other geometrical building blocks.

Top surface **115a** may include other strut networks and/or connections. In some embodiments, bottom surface **115b** may mirror the top surface (and/or have other designs). In some
5 embodiments, top surface **115a** and bottom surface **115b** may engage respective surfaces of two adjacent vertebrae when implant **100** is implanted.

[0039] As depicted in FIG. 1B, implant **100** may include lordosis (e.g., an angle in top and/or bottom surfaces **115a,b** approximately in a range of 4 to 15 degrees (such as 4, 5, 6, 7, 8, 9, 10,
10 11, 12, 13, 14, or 15 degrees)) to further support the adjacent vertebrae when implanted. As described above, lordosis may include an angled orientation of surfaces (e.g., top and bottom) that provide for differences in thickness in the anterior and posterior portions of the implant such that the implant is conducive for supporting the curvature of a vertebral column. In the illustrated embodiment, the thickness of implant **100** is greater at or near the anterior portion **118**
15 and lesser at or near the posterior portion **120** of the implant. In the illustrated embodiment, the side portions of external truss structure are arranged substantially vertically, and the lordosis is formed by the angles of the top portion **111** and bottom portion **112** of external truss structure. For example, in the illustrated embodiment, top portion **111** and bottom portion **112** of external truss structure are not perpendicular to the vertical plane defined by the side portion **113**. Rather,
20 the top portion **111** and bottom portion **112** are arranged with an acute angle relative to the vertical plane of side portion **113** at or near the anterior region **118** of implant **100** and with an obtuse angle relative to the vertical plane of side portion **113** at or near posterior region **120** of implant **100**. As depicted, the vertical struts that form the planar truss of side portion **113** of external truss structure proximate posterior region **120** of implant **100** are shorter than struts that
25 form side portion of external truss structure proximate anterior region **118** of implant **100**. In the illustrated embodiment, in which the vertical trusses are substantially evenly spaced, the struts forming the "X" cross members of the side planar trusses proximate the posterior region **120** of implant **100** are shorter than struts forming the "X" cross members of the side planar trusses proximate the anterior region **118** of implant **100**. Other embodiments may include variations in
30 the arrangement of the trusses to provide various configurations of the implant. For example, in some embodiments only one or neither of the top and bottom external truss portions may be non-perpendicular to the side portions of the external truss proximate the anterior and posterior portions of the implant. Further, the side, top, and/or bottom portions may include multiple planar trusses angled relative to one another in any orientation. For example, the top or bottom

portions may include four planar trusses, each formed of multiple truss units, such that the portion(s) includes a pyramidal like shape.

[0040] In some embodiments, the implant may not include lordosis. For example, FIGS. 2A-2B illustrate two views of an embodiment of an implant **200** without lordosis. In some
5 embodiments, the top surface and bottom surface may not include connecting struts. For example, FIGS. 2C-2D illustrate two views of implant **250** without outer struts (e.g., without external truss portions formed of planar trusses). In the illustrated embodiment, implant **250** includes an internal web structure and does not include an external truss structure. For example, in the illustrated embodiment, the exterior faces of implant **250** are defined by a plurality of truss
10 units that are angled relative to each of its adjacent truss units. The relative alignment of the truss units results in a non-planar exterior that includes a plurality of pointed junctions. The pointed junctions (e.g., pointed junction **201**) may operate to dig into the surrounding bone to hold the implant in place (for example, if the implant is being used in a corpectomy device).

[0041] FIGS. 5A-5C illustrate progressive sectioned views of implant **100** showing the internal structure of implant **100**, according to an embodiment. FIG. 5A illustrates a sectioned view of a
15 lower portion of implant **100**. Bottom surface **115b** is shown with various struts (e.g., struts **103**) extending upward from bottom surface **115b**. FIG. 5B illustrates a sectioned view approximately mid-way through implant **100**. Struts, such as struts **103e,f**, shared by various stacked tetrahedrons in the web structure are shown. Some struts extend through central portion **501a**
20 and/or **501b** of implant **100**. FIG. 5B also shows central portions **501a,b** of implant **100**. In some embodiments, central portion **501a** may include a rectangular region that has a width of approximately 50% of the implant width, a height of approximately 50% of the implant height, and a length of approximately 50% of the implant length and located in the center of implant **100**. In some embodiments, central portion **501b** may encompass a region (e.g., a spherical
25 region, square region, etc.) of approximately a radius of approximately 1/8 to 1/4 of the width of implant **100** around a position located approximately at one half the width, approximately one half the length, and approximately one-half the height of implant **100** (i.e., the center of implant **100**). Other central portions are also contemplated. For example, the central portion may include a square region with a length of one of the sides of the square region approximately 1/4 to
30 1/2 the width of implant **100** around a position approximately at one half the width, approximately one half the length, and approximately one half the height of the implant. An example height **502a**, width **502b**, and length **502c**, is shown in FIG. 5D. In some embodiments, the height may be up to about 75mm or more. In some embodiments, such as those used for long bone reconstruction, the width and/or length could be approximately 7 inches or longer. In some

embodiments, the width, length, and/or height may vary along implant **100** (e.g., the height may vary if the implant includes lordosis). The height may be taken at one of the opposing sides, the middle, and/or may be an average of one or more heights along the length of implant **100**. The web structure may extend through central portion **501a,b** of the implant (e.g., at least one strut of the web structure may pass at least partially through central portion **501a,b**). FIG. 5C illustrates another sectioned view showing sectioned views of top tetrahedrons in the web structure. FIG. 5D shows a complete view of implant **100** including top surface **115a** with vertices **301a-d**.

[0042] FIGS. 6A-6D illustrate alternate embodiments of an implant. In some embodiments, different sections of the hexahedron-shaped geometric design may be used. For example, as seen in FIG. 6A, the bottom half of the hexahedron-shaped geometric design may be used (primarily including the lower tetrahedron structures). If using the bottom half of the design, implant **600** may be expanded proportionately to have similar overall dimensions as the hexahedron-shaped geometric design (e.g., the tetrahedrons may be expanded to approximately twice the height of the tetrahedrons in the hexahedron-shaped geometric design to give implant **600** a height approximately the same as the hexahedron-shaped geometric design). In some embodiments, implant **600** may also be angled (e.g., on top surface **601a** and/or bottom surface **601b**) to provide implant **600** with lordosis to, in some embodiments, have a better fit between the vertebral endplates. Top surface **601a** and/or bottom surface **601b** may also include struts to connect nodes of implant **600** (e.g., see the strut network on the top surface in FIG. 6a). Other patterns of struts for top surface **601a** and/or bottom surface **601b** may also be used. In some embodiments, implant **600** may not include negative angles between struts and may thus be easier to create through a casting or molding process.

[0043] FIGS. 6C-6D illustrate another alternate embodiment of an implant. In some embodiments, approximately the middle 40 to 60 percent of the hexahedron-shaped geometric design may be used in implant **650**. For example, if an overall height of the hexahedron-shaped geometric design is approximately 37 mm, approximately the bottom 10 mm and approximately the top 10 mm of the design may be removed and approximately the middle 17 mm of the design may be used for the implant. Middle portion of implant **650** may then be expanded proportionately such that the approximate height of the expanded design may be approximately 37 mm (or a different height as needed). Top surface **651a** and bottom surface **651b** may include a network of struts (e.g., see the struts on top surface **651a** of FIG. 6C) (other networks of struts are also contemplated). Other portions of the design for the implant are also contemplated (e.g., the top half of the design shown in FIG. 1A, the bottom half of the design shown in FIG. 1A, etc). Design portions may be proportionately expanded to meet specified dimensions (e.g.,

specified height, width, and length). In some embodiments, the amount of struts may be reduced or material in the implant may be redistributed so that some struts may have a larger diameter and some may have a smaller diameter (e.g., the different diameters may reinforce against different directional forces). In some embodiments, a partial-design cage may be used (e.g., with
5 half of the web structure so that the structure includes a tetrahedron. Further, in some embodiments, the implant may include angled surfaces (e.g., an angled top surface **651a** and/or angled bottom surface **651b**) to provide lordosis for implants to be implanted between the vertebral endplates.

[0044] In some embodiments, the web structure of an implant may distribute forces throughout
10 the implant when implanted. For example, the connecting struts of the web structure may extend throughout the core of an implant, and the interconnectivity of struts may disperse the stress of compressive forces throughout implant to reduce the potential of stress risers (the distribution of forces throughout the implant may prevent concentration of stress on one or more portions of the vertebrae that may otherwise result in damage to the vertebrae).

[0045] In some embodiments, the web structure might be used as a lens to focus forces and strain
15 specifically as a regional accelerant or retardant to bone growth. In this consideration, micromechanical alignment of force transduction would be used for alignment of scoliotic intervertebral articulations, for physéal shaping in varus and valgus misalignments, and in other anticipated redirectional applications.

[0046] In some embodiments, the web structure of an implant (e.g., the external and internal
20 struts of the implant) may also provide surface area for bone graft fusion. For example, the web structure extending throughout an implant may add additional surface areas (e.g., on the surface of the struts making up the implant) to fuse to the bone graft material and prevent bone graft material from loosening or migrating from the implant. In some embodiments, the web structure
25 may also support bone in-growth. For example, when implanted, adjacent bone (e.g., adjacent vertebrae if the implant is used as a spinal implant) may grow over at least a portion of struts of the implant. The bone growth and engagement between the bone growth and the implant may further stabilize the implant. In some embodiments, the surfaces of the implant may be formed with a rough surface to assist in bone in-growth adhesion.

[0047] In some embodiments, struts may have a diameter approximately in a range of about
30 0.025 to 5 millimeters (mm) (e.g., 1.0 mm, 1.5 mm, 3 mm, etc). Other diameters are also contemplated (e.g., greater than 5 mm). In some embodiments, the struts may have a length approximately in a range of 0.5 to 20 mm (e.g., depending on the implant size needed to, for example, fit a gap between vertebral endplates). As another example, struts may have a length

approximately in a range of 30-40 mm for a hip implant. In some embodiments, the reduced strut size of the web structure may allow the open cells in implant 100 to facilitate bone growth (e.g., bone may grow through the open cells once implant 100 is implanted in the body). Average subsidence for implants may be approximately 1.5 mm within the first 3 weeks post op
5 (other subsidence is also possible (e.g., approximately between 0.5 to 2.5 mm)). A strut size that approximately matches the subsidence (e.g., a strut size of approximately 1.5 mm in diameter and a subsidence of approximately 1.5 mm) may result in a net 0 bone growth (e.g., the bone growth growing around the struts) after the implant has settled in the implanted position. The net 0 bone growth throughout the entire surface area of the implant/vertebrae endplate interface may result
10 in a larger fusion column of bone that may result in more stable fusion. Other fusion column sizes are also contemplated. The configuration of the implant may redistribute the metal throughout the implant. In some embodiments, a rim may not be included on the implant (in some embodiments, a rim may be included). The resulting bone growth (e.g., spinal column) may grow through the implant.

15 **[0048]** In some embodiments, greater than 50% of the interior volume of implant 100 may be open. In some embodiments, greater than 60%, greater than 70%, and/or greater than 80% of implant 100 may be open (e.g., 95%). In some embodiments, the open volume may be filled with bone growth material. For example, cancellous bone may be packed into an open/internal region of implant.

20 **[0049]** In some embodiments, at least a portion of the surfaces of the implant may be coated/treated with a material intend to promote bone growth and/or bone adhesion and/or an antimicrobial agent to prevent infections. For example, in some embodiments, the surface of the struts may be coated with a biologic and/or a bone growth factor. In some embodiments, a biologic may include a coating, such as hydroxyapatite, bone morphaginic protein (BMP),
25 insulin-like growth factors I and II, transforming growth factor-beta, acidic and basic fibroblast growth factor, platelet-derived growth factor, and/or similar bone growth stimulant that facilitates good biological fixation between the bone growth and a surface of the implant. In some embodiments, a bone growth factor may include a naturally occurring substance capable of stimulating cellular growth, proliferation and cellular differentiation (e.g., a protein or steroid
30 hormone). In some embodiments, the surface of the implant (e.g., the struts, the external truss structure, etc.) may be coated with collagen.

[0050] In some embodiments, a biologic and/or growth factor may be secured to a central region of an implant. For example, in some embodiments, a biologic or growth factor may be provided on at least a portion of a strut that extends through central portion **501a** and/or **501b** of implant

100, see FIG. 5B. Such an embodiment may enable the delivery of a biologic and or a growth factor to a central portion of an implant. For example, the biologic or growth factor may be physically secured to a strut in a central portion of the implant as opposed to being packed into an open volume that does not include a strut provided therein for the physical attachment of the
5 biologic and/or growth factor.

[0051] As the implant settles into the implant site, subsidence may place additional pressure on the bone graft material (which may already be under compressive forces in the implant) and act to push the bone graft material toward the sides of the implant (according to Boussinesq's theory of adjacent material, when a force is applied to a member that is adjacent to other materials (such
10 as sand, dirt, or bone graft material) the force against the member creates a zone of increased pressure (e.g., 60 degrees) in the adjacent material). Struts of the implant may resist bone graft material protrusion from the sides of the web structure and may increase the pressure of the bone graft material. Bone graft material may need to be implanted in a higher-pressure environment to create an environment conducive to strong bone growth (e.g., according to Wolf's law that bone
15 in a healthy person or animal will adapt to the loads it is placed under). The web structure may thus increase the chance of stronger fusion.

[0052] Web structures formed from other truss configurations are also contemplated. For example, the trusses may include a series of packing triangles, a two-web truss, a three-web truss, etc. Further, the web structure for an implant may include one or more trusses as described
20 in U.S. Patent No. 6,931,812 titled "Web Structure and Method For Making the Same", which issued August 23, 2005, which is hereby incorporated by reference in its entirety as though fully and completely set forth herein.

[0053] FIG. 8 illustrates a flowchart of a method for making an implant. In some embodiments, an implant may be made through rapid prototyping (e.g., electron beam melting, laser sintering,
25 etc). It should be noted that in various embodiments of the methods described below, one or more of the elements described may be performed concurrently, in a different order than shown, or may be omitted entirely. Other additional elements may also be performed as desired. In some embodiments, a portion or the entire method may be performed automatically by a computer system.

[0054] At 1001, a three dimensional model of an implant is generated and stored in a storage medium accessible to a controller operable to control the implant production process. At 1003, a layer of material (e.g., a powder, liquid, etc.) is applied to a support. In some embodiments, the powder may include γ TiAl (γ Titanium Aluminides) which may be a high strength/low weight material. Other materials may also be used. The powder may be formed using a gas atomization

process and may include granules with diameters approximately in a range of 20 to 200 micrometers (μm) (e.g., approximately 80 μm). The powder may be delivered to the support through a distributor (e.g., delivered from a storage container). The distributor and/or the support may move during distribution to apply a layer (e.g., of powder) to the support. In some
5 embodiments, the layer may be approximately a uniform thickness (e.g., with an average thickness of 20 to 200 micrometers (μm)). In some embodiments, the distributor and support may not move (e.g., the material may be sprayed onto the support). At 1005, the controller moves an electron beam relative to the material layer. In some embodiments, the electron beam generator may be moved, and in some embodiments the support may be moved. If the material is
10 γTiAl , a melting temperature approximately in a range of 1200 to 1800 degrees Celsius (e.g., 1500 degrees Celsius) may be obtained between the electron beam and the material. At 1007, between each electron beam pass, additional material may be applied by the distributor. At 1009, the unmelted material is removed and the implant cooled (e.g., using a cool inert gas). In some
15 embodiments, the edges of the implant may be smoothed to remove rough edges (e.g., using a diamond sander). In some embodiments, the implant may include rough edges to increase friction between the implant and the surrounding bone to increase adhesion of the implant to the bone.

[0055] Other methods of making an implant are also contemplated. For example, an implant may be cast or injection molded. In some embodiments, multiple parts may be cast or injection
20 molded and joined together (e.g., through welding, melting, etc). In some embodiments, individual struts forming the implant may be generated separately (e.g., by casting, injection molding, etc.) and welded together to form the implant. In some embodiments, multiple implants of different sizes may be constructed and delivered in a kit. A medical health professional may choose an implant (e.g., according to a needed size) during the surgery. In some embodiments,
25 multiple implants may be used at the implant site.

[0056] Specialized tools may be used to insert the implants described herein. Examples of tools that may be used are described in U.S. Published Patent Applications Nos.: 2010/0161061; 2011/0196495; 20110313532; and 2013/0030529, each of which is incorporated herein by reference.

30 [0057] FIG. 9 illustrates a flowchart of a method for implanting a spinal implant, according to an embodiment. It should be noted that in various embodiments of the methods described below, one or more of the elements described may be performed concurrently, in a different order than shown, or may be omitted entirely. Other additional elements may also be performed as desired.

In some embodiments, a portion or the entire method may be performed automatically by a computer system.

[0058] At step **1301**, an intersomatic space is accessed. For example, an anterior opening may be made in a patient's body for an anterior lumbar inter-body fusion (ALIF) approach or a
5 posterior opening may be made for a posterior lumbar inter-body fusion (PLIF) approach. At **1303**, at least a portion of the intersomatic space is excised to form a cavity in the intersomatic space. At **1305**, the implant is inserted into the cavity in the intersomatic space. In some embodiments, a handler, or some other device, is used to grip the implant. In some
10 embodiments, a force may be applied to the implant (e.g., through a hammer) to insert the implant into the cavity. At **1307**, before and/or after insertion of the implant, the implant and/or space in the cavity may be packed with bone graft material. At **1309**, the access point to the intersomatic space may be closed (e.g., using sutures).

[0059] In some embodiments, the implant may be customized. For example, three dimensional measurements and/or shape of the implant may be used to construct an implant that distributes
15 the web structure throughout a three-dimensional shape design.

[0060] In some embodiments, a truss/web structure may be disposed on at least a portion of an implant to facilitate coupling of the implant to an adjacent structure. For example, where an implant is implanted adjacent a bony structure, one or more truss structures may be disposed on
20 and/or extend from a surface (e.g., an interface plate) of the implant that is intended to contact, and at least partially adhere to, the bony structure during use. In some embodiments, such as those including an intervertebral implant disposed between the end plates of two adjacent vertebrae during, one or more truss structures may be disposed on a contact surface of the intervertebral implant to facilitate bone growth that enhances coupling of the intervertebral
25 implant to the bony structure. For example, a truss structure may include one or more struts that extend from the contact surface to define an open space for bone growth therethrough, thereby enabling bone through growth to interlock the bone structure and the truss structure with one another to couple the implant to the bony structure at or near the contact face. Such interlocking
30 bone through growth may inhibit movement between the implant and the bony structure which could otherwise lead to loosening, migration, subsidence, or dislodging of the implant from the intended position. Similar techniques may be employed with various types of implants, including those intended to interface with tissue and/or bone structures. For example, a truss structure may be employed on a contact surface of knee implants, in a corpectomy device, in a hip replacement, in a knee replacement, in a long bone reconstruction scaffold, or in a cranio-maxifacial implant hip implants, jaw implant, an implant for long bone reconstruction, foot and

ankle implants, shoulder implants or other joint replacement implants or the like to enhance adherence of the implant to the adjacent bony structure or tissue. Examples of truss structures, and other structures, that may extend from the surface of an implant to facilitate coupling of the implant to an adjacent structure are described in U.S. Published Patent Application No.

5 2011/0313532, which is incorporated herein by reference.

[0061] While implants described herein are depicted as being composed of substantially straight struts, it should be understood that the struts can be non-linear, including, but not limited to curved, arcuate and arch shaped. Examples of implants having non-linear struts are described in U.S. Patent Application No. 13/668,968, which is incorporated herein by reference.

10 **[0062]** Many bone structures in the human body need to have some flexibility for proper movement. For example, disks in the human spine need flexibility to accommodate the movement of the subject. Disks in the human spine exhibit viscoelastic properties. Under normal body weight, the disks creep, that is they get shorter with time. Lying down allows the spinal disks to recover their original shape. In an embodiment, an implant may include a web structure that includes a plurality of struts joined at nodes, the web structure having an interface for bone tissue. The implant may include one or more elastic material to impart flexibility. In some embodiments, the implant may include one or more viscoelastic materials. A flexible material that may be used for the struts of an implant includes nickel-titanium alloys (e.g., nitinol). Other materials that may be incorporated into the implant include polymeric fibrous materials such as described in U.S. Patent No. 7,905,921, which is incorporated herein by reference.

15 **[0063]** In an embodiment, depicted in FIG. 10, implant **400** includes a frame or support **410** and a plurality of cables **420** coupling different portions of support **410**. Cables **420** may be coupled to opposing portions of implant support **410**. For example, as depicted cables **420** may connect opposing sides of implant support. Cables may also connect opposing portions of support **410** at different planes. For example, a cable may couple upper part **412** of support to lower part **414** of support. The cables may include at least one end that is accessible (e.g., sticks out of the web structure) such that the tension on the cables may be altered by applying a force to at least one end of the wire. The cables may be coupled to a tension altering device **430**. During use operation of the tension altering device alters the tension on the cables. The cables may allow the device to be customized to match non-uniform stresses across the implant during use.

20 **[0064]** It has been discovered that small electrical charges may be used to induce increased BMP production from osteogenic cells. The difficulty, in practice, would be how to supply an implant with a power source that could generate the electrical charges to stimulate BMP production.

Piezoelectric materials are materials that create an electric charge when subjected to mechanical stress. In an embodiment, an implant may be formed from titanium, or other conductive material, and a piezoelectric material may be coated on at least a portion of the struts. When implanted, the struts undergo mechanical stress due to the changing forces applied to the implant
5 as the subject moves. The mechanical stress causes the piezoelectric material coated on the struts to produce electric charges that stimulate the production of BMP from attached osteoblasts. Examples of piezoelectric materials that may be used include, but are not limited to, gallium orthophosphate (GaPO_4), langasite ($\text{La}_3\text{Ga}_5\text{SiO}_{14}$), barium titanate (BaTiO_3), Lead titanate (PbTiO_3), lead zirconate titanate ($\text{Pb}[\text{Zr}_x\text{Ti}_{1-x}]\text{O}_3$ $0 \leq x \leq 1$, "PZT"), potassium niobate (KNbO_3),
10 lithium niobate (LiNbO_3), lithium tantalate (LiTaO_3), sodium tungstate (Na_2WO_3), zinc oxide (ZnO), $\text{Ba}_2\text{NaNb}_5\text{O}_{15}$, $\text{Pb}_2\text{KNb}_5\text{O}_{15}$, sodium potassium niobate ($(\text{K},\text{Na})\text{NbO}_3$), bismuth ferrite (BiFeO_3), sodium niobate (NaNbO_3), bismuth titanate ($\text{Bi}_4\text{Ti}_3\text{O}_{12}$), sodium bismuth titanate ($\text{Na}_{0.5}\text{Bi}_{0.5}\text{TiO}_3$), and polyvinylidene fluoride (PVDF).

[0065] The physical properties of the struts of the implant may be varied such that the diameter
15 and/or density of a first portion of a strut is different than a diameter of the second portion of a strut. In some embodiments, the first portion of the strut may be formed from a material that is different from the material used to form the second portion of the strut. In some embodiments, the first portion of the strut has a density that is different from the density of the second portion of the strut. In some embodiments, the first portion of a strut may have a porosity that is
20 different from the porosity of the second portion of the strut. Any combination of these different physical properties may be present in an implant to help optimize the distribution of stress throughout the implant. FIG. 11 depicts a strut having different diameters.

[0066] Electrospun materials may also be used to create electric charges in an implant. Materials formed from an electrospinning process generally are charged materials, since electrospinning
25 relies on this charge to draw the fibers. In an embodiment, an implant may be formed from titanium, or other conductive material, and an electrospun material (e.g., a ceramic or polymer) may be coated on at least a portion of the struts. When implanted, the struts undergo mechanical stress due to the changing forces applied to the implant as the subject moves. The mechanical stress causes the electrically charged electrospun material coated on the struts to produce electric
30 charges that stimulate the production of BMP from attached osteoblasts.

[0067] In accordance with the above descriptions, in various embodiments, an implant may include a web structure. The web structure for the implant may include a micro truss design. In some embodiments, the micro truss design may include a web structure with multiple struts. Other web structures are also contemplated. The web structure may extend throughout the

implant (including a central portion of the implant). The web structure may thus reinforce the implant along multiple planes (including internal implant load bearing) and provide increased area for bone graft fusion. The web structure may be used in implants such as spinal implants, corpectomy devices, hip replacements, knee replacements, long bone reconstruction scaffolding, and cranio-maxifacial implants. Other implant uses are also contemplated. In some 5 embodiments, the web structure for the implant may include one or more geometric objects (e.g., polyhedrons). In some embodiments, the web structure may not include a pattern of geometrical building blocks (e.g., an irregular pattern of struts may be used in the implant). In some embodiments, the web structure may include a triangulated web structure including two or more 10 tetrahedrons. A tetrahedron may include four triangular faces in which three of the four triangles meet at each vertex. The web structure may further include two tetrahedrons placed together at two adjacent faces to form a web structure with a hexahedron-shaped frame (including six faces). In some embodiments, multiple hexahedron-shaped web structures may be arranged in a side-by-side manner. The web structures may connect directly through side vertices (e.g., two or 15 more hexahedron-shaped web structures may share a vertex). In some embodiments, the web structure may be angled to provide lordosis to the implant.

[0068] In this patent, certain U.S. patents, U.S. patent applications, and other materials (e.g., articles) have been incorporated by reference. The text of such U.S. patents, U.S. patent applications, and other materials is, however, only incorporated by reference to the extent that no 20 conflict exists between such text and the other statements and drawings set forth herein. In the event of such conflict, then any such conflicting text in such incorporated by reference U.S. patents, U.S. patent applications, and other materials is specifically not incorporated by reference in this patent.

[0069] Further modifications and alternative embodiments of various aspects of the invention 25 may be apparent to those skilled in the art in view of this description. For example, although in certain embodiments, struts have been described and depicts as substantially straight elongated members, struts may also include elongated members curved/arched along at least a portion of their length. Accordingly, this description is to be construed as illustrative only and is for the purpose of teaching those skilled in the art the general manner of carrying out the invention. It is 30 to be understood that the forms of the invention shown and described herein are to be taken as embodiments. Elements and materials may be substituted for those illustrated and described herein, parts and processes may be reversed, and certain features of the invention may be utilized independently, all as would be apparent to one skilled in the art after having the benefit of this description of the invention. Changes may be made in the elements described herein without

departing from the spirit and scope of the invention as described in the following claims. Furthermore, it is noted that the word “may” is used throughout this application in a permissive sense (i.e., having the potential to, being able to), not a mandatory sense (i.e., must). The term “include”, and derivations thereof, mean “including, but not limited to”. As used in this
5 specification and the claims, the singular forms “a”, “an” and “the” include plural referents unless the content clearly indicates otherwise. Thus, for example, reference to “a strut” includes a combination of two or more struts. The term “coupled” means “directly or indirectly connected”.

WHAT IS CLAIMED IS:

1. An implant for interfacing with a bone structure, comprising:

5 a web structure comprising a plurality of struts joined at nodes, wherein the web structure is configured to interface with human bone tissue;

wherein one or more of the struts are composed of an elastic material.
- 10 2. The implant of claim 1, wherein the one or more struts composed of an elastic material are placed in positions that allow the implant to flex during use.
3. The implant of claim 1 or 2, wherein the web structure comprises a space truss comprising two or more planar truss units.
- 15 4. The implant of any one of claims 1-3, wherein the at least some of the struts define triangular trusses having at least one node shared by two different triangular planar truss units having different corresponding angles.
- 20 5. The implant of claim 3, wherein one or more of the planar truss units comprise one or more planar triangular truss units having three substantially straight struts and three nodes in a triangular configuration.
6. The implant of claim 3, wherein one or more of the planar truss units are coupled to one
25 another such that one or more planar truss units lie in a plane that is not substantially parallel to a plane of a planar truss unit that shares at least one strut with the one or more planar truss units.
7. The implant of claim 3, wherein one or more of the planar truss units define an exterior surface of the web structure.
- 30 8. The implant of claim 3, wherein one or more of the planar truss units comprises a first planar triangular truss unit coupled to a second planar triangular truss unit, wherein the first and second planar triangular truss units are coupled in an opposing manner with a single node defining the apex of each planar triangular truss unit.

9. A method of repairing a bone structure, comprising:

obtaining an implant as described in any one of claims 1-8; and

5

coupling the implant to the bone structure.

10. An implant for interfacing with a bone structure, comprising:

10 a web structure comprising a space truss comprising a plurality of struts joined at nodes,
wherein the web structure is configured to interface with human bone tissue;

wherein one or more of the struts are composed of a nickel- titanium alloy.

15 11. The implant of claim 10, wherein the one or more struts composed of a nickel- titanium
alloy are placed in positions that allow the implant to flex during use.

12. The implant of claim 10, wherein all struts of the implant are composed of a nickel-
titanium alloy.

20

13. The implant of any one of claims 10-12, wherein the web structure comprises a space truss
comprising two or more planar truss units.

14. The implant of any one of claims 10-12, wherein the at least some of the struts define
25 triangular trusses having at least one node shared by two different triangular planar truss units
having different corresponding angles.

15. The implant of claim 13, wherein one or more of the planar truss units comprise one or
more planar triangular truss units having three substantially straight struts and three nodes in a
30 triangular configuration.

16. The implant of claim 13, wherein one or more of the planar truss units are coupled to one
another such that one or more planar truss units lie in a plane that is not substantially parallel to a
plane of a planar truss unit that shares at least one strut with the one or more planar truss units.

17. The implant of claim 13, wherein one or more of the planar truss units define an exterior surface of the web structure.

5 18. The implant of claim 13, wherein one or more of the planar truss units comprises a first planar triangular truss unit coupled to a second planar triangular truss unit, wherein the first and second planar triangular truss units are coupled in an opposing manner with a single node defining the apex of each planar triangular truss unit.

10 19. A method of repairing a bone structure, comprising:

obtaining an implant as described in any one of claims 10-18; and

coupling the implant to the bone structure.

15

20. An implant for interfacing with a bone structure, comprising:

a web structure comprising a plurality of struts joined at nodes, wherein the web structure is configured to interface with human bone tissue;

20

wherein one or more of the struts are composed of a viscoelastic material.

21. The implant of claim 20, wherein the one or more struts composed of a viscoelastic material are placed in positions that allow the implant to flex during use.

25

22. The implant of claim 20 or 21, wherein the web structure comprises a space truss comprising two or more planar truss units.

23. The implant of claim 20 or 21, wherein the at least some of the struts define triangular
30 trusses having at least one node shared by two different triangular planar truss units having different corresponding angles.

24. The implant of claim 23, wherein one or more of the planar truss units comprise one or more planar triangular truss units having three substantially straight struts and three nodes in a triangular configuration.
- 5 25. The implant of claim 23, wherein one or more of the planar truss units are coupled to one another such that one or more planar truss units lie in a plane that is not substantially parallel to a plane of a planar truss unit that shares at least one strut with the one or more planar truss units.
- 10 26. The implant of claim 23, wherein one or more of the planar truss units define an exterior surface of the web structure.
- 15 27. The implant of claim 23, wherein one or more of the planar truss units comprises a first planar triangular truss unit coupled to a second planar triangular truss unit, wherein the first and second planar triangular truss units are coupled in an opposing manner with a single node defining the apex of each planar triangular truss unit.
28. A method of repairing a bone structure, comprising:
- 20 obtaining an implant as described in any one of claims 20-27; and
- coupling the implant to the bone structure.

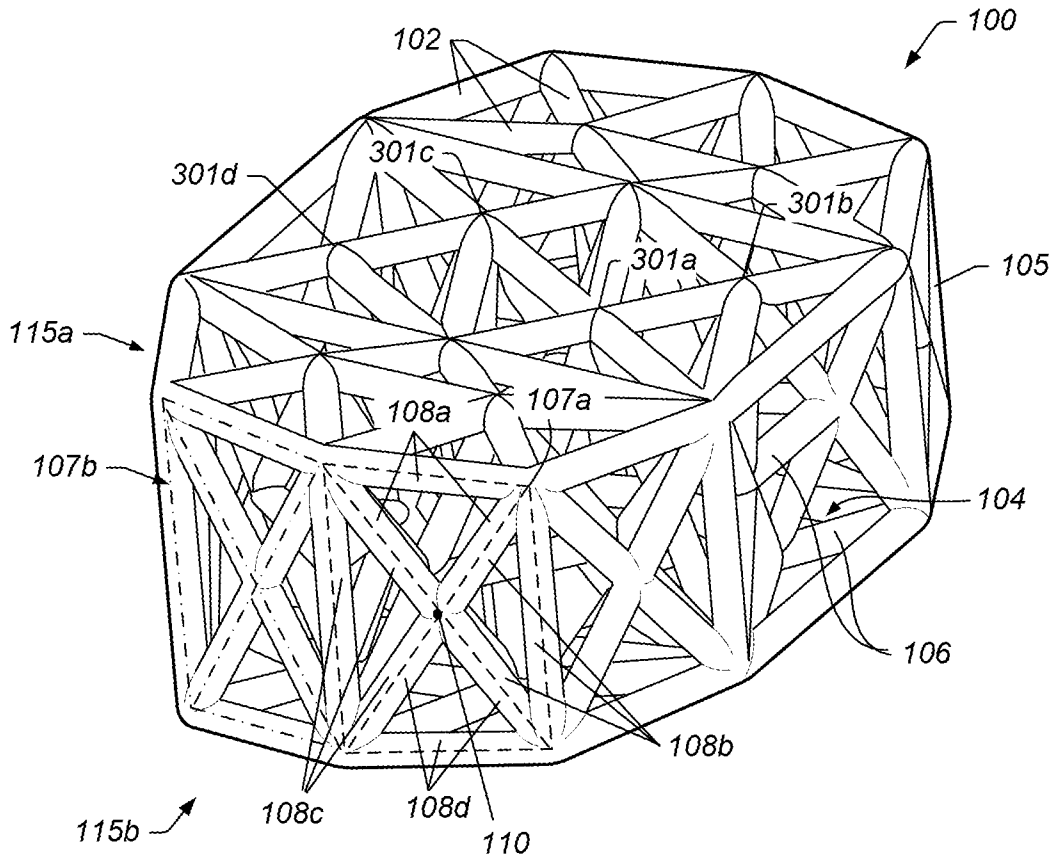

FIG. 1A

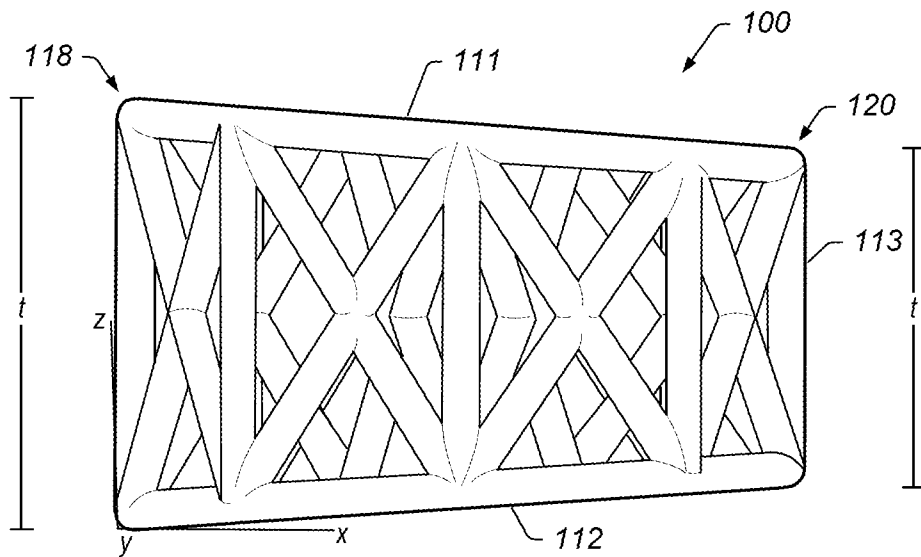

FIG. 1B

2 / 17

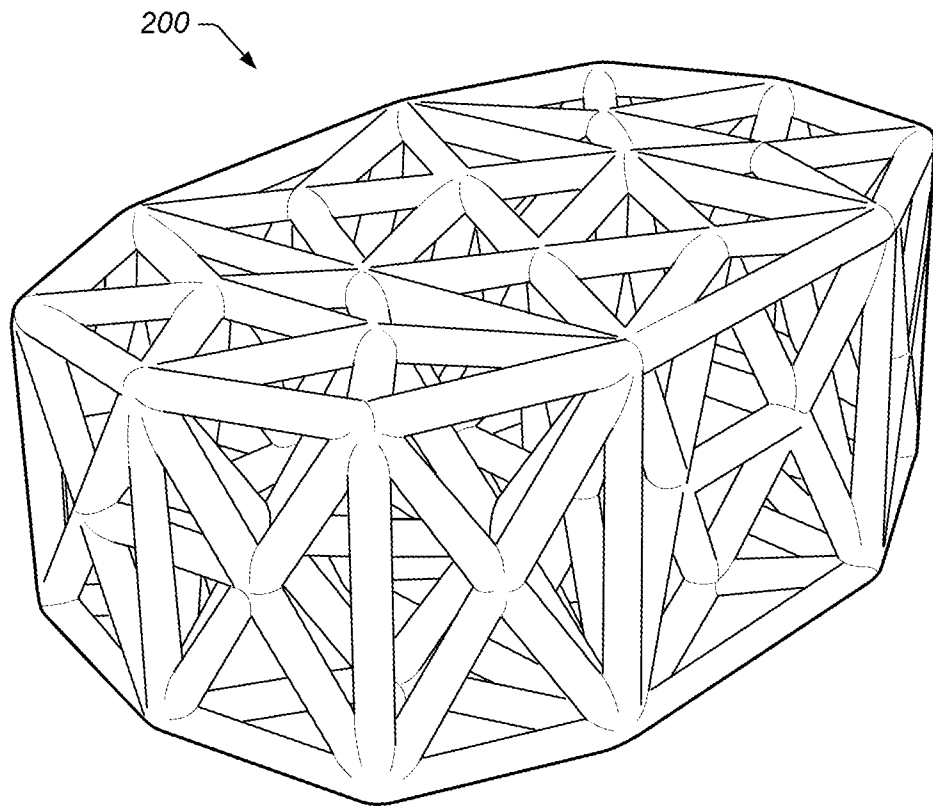

FIG. 2A

3 / 17

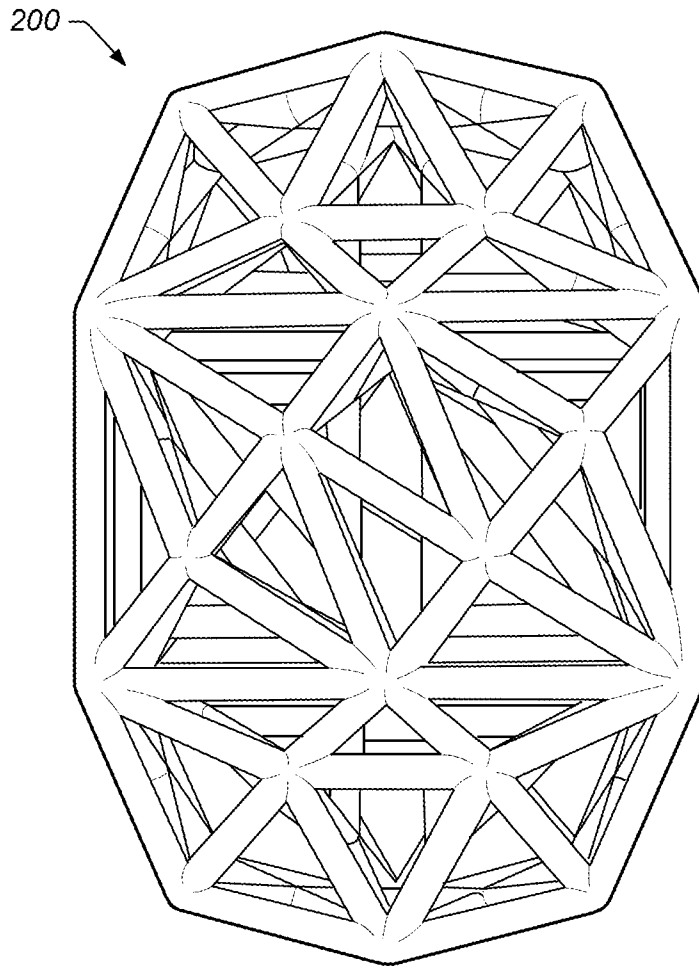

FIG. 2B

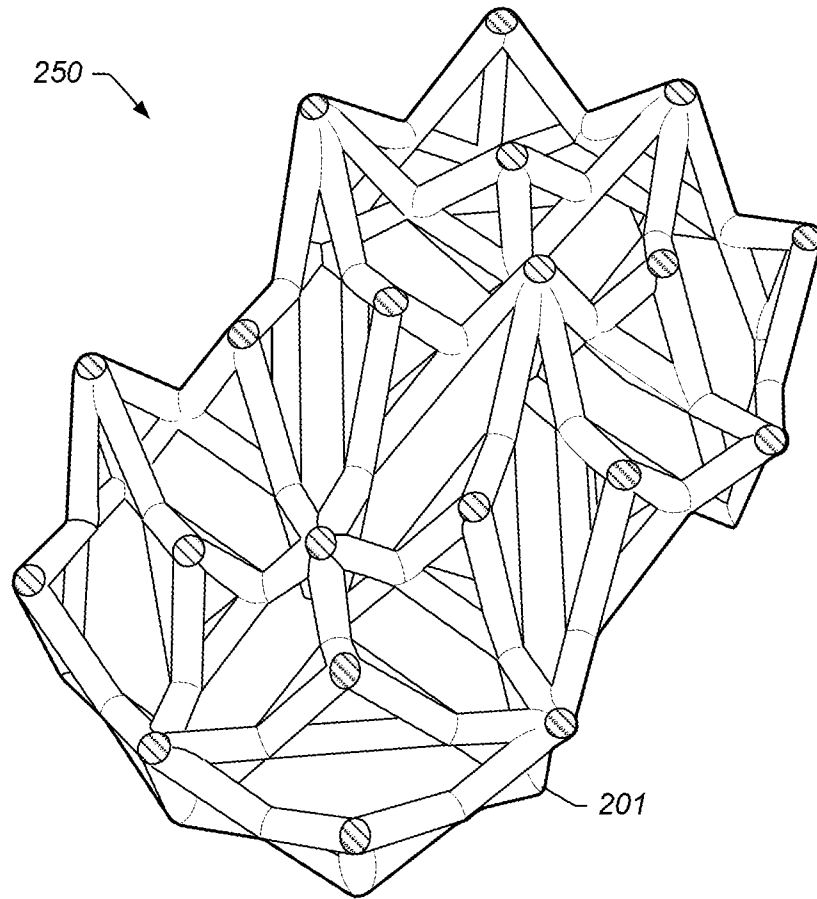

FIG. 2C

5 / 17

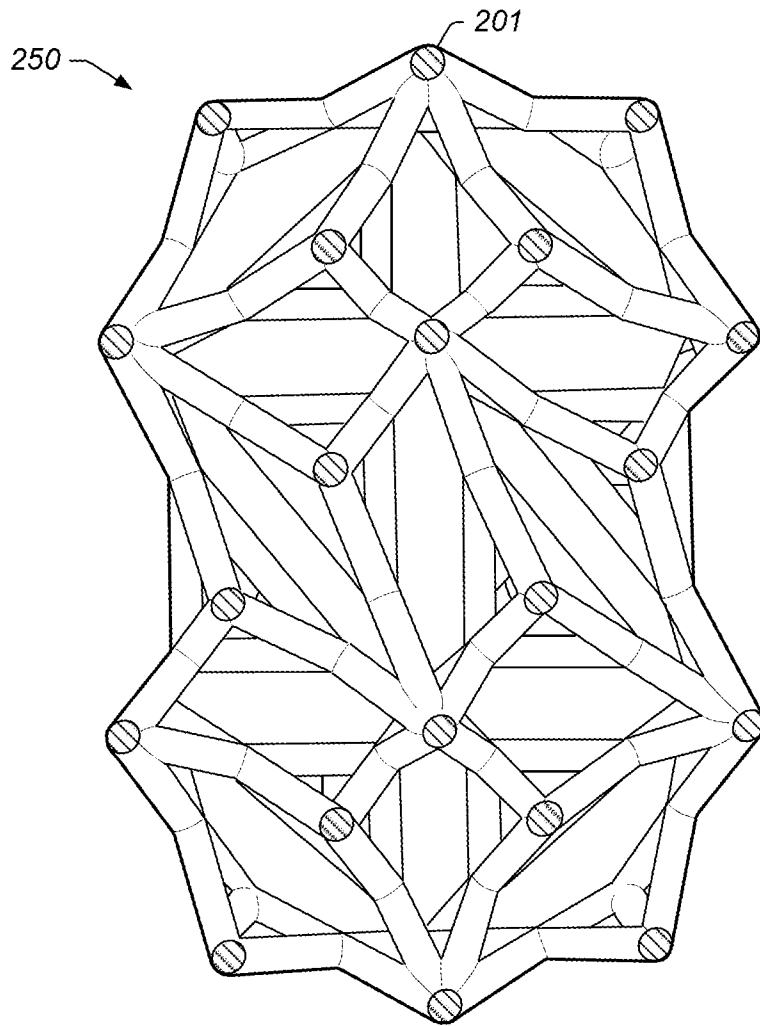

FIG. 2D

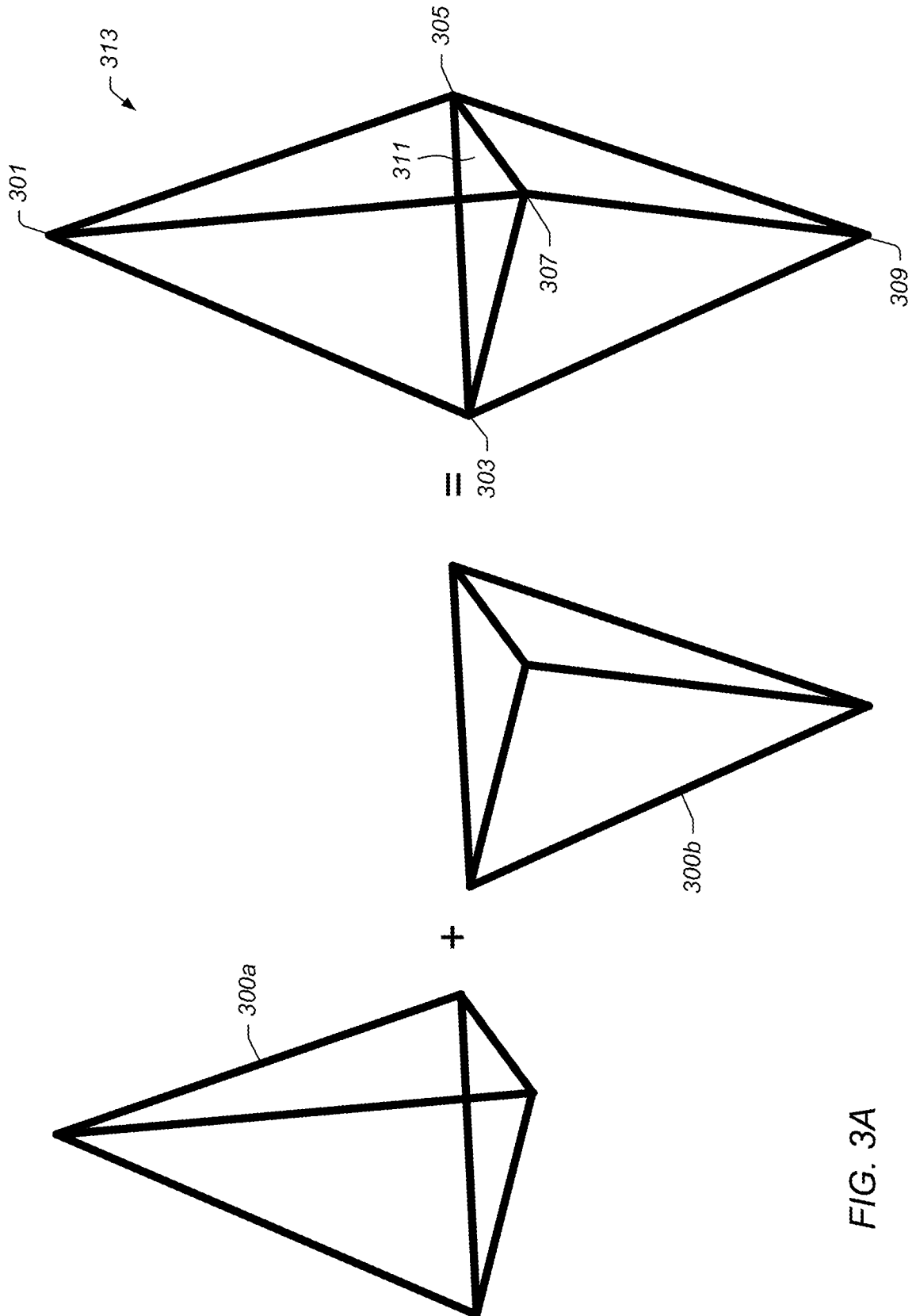

FIG. 3A

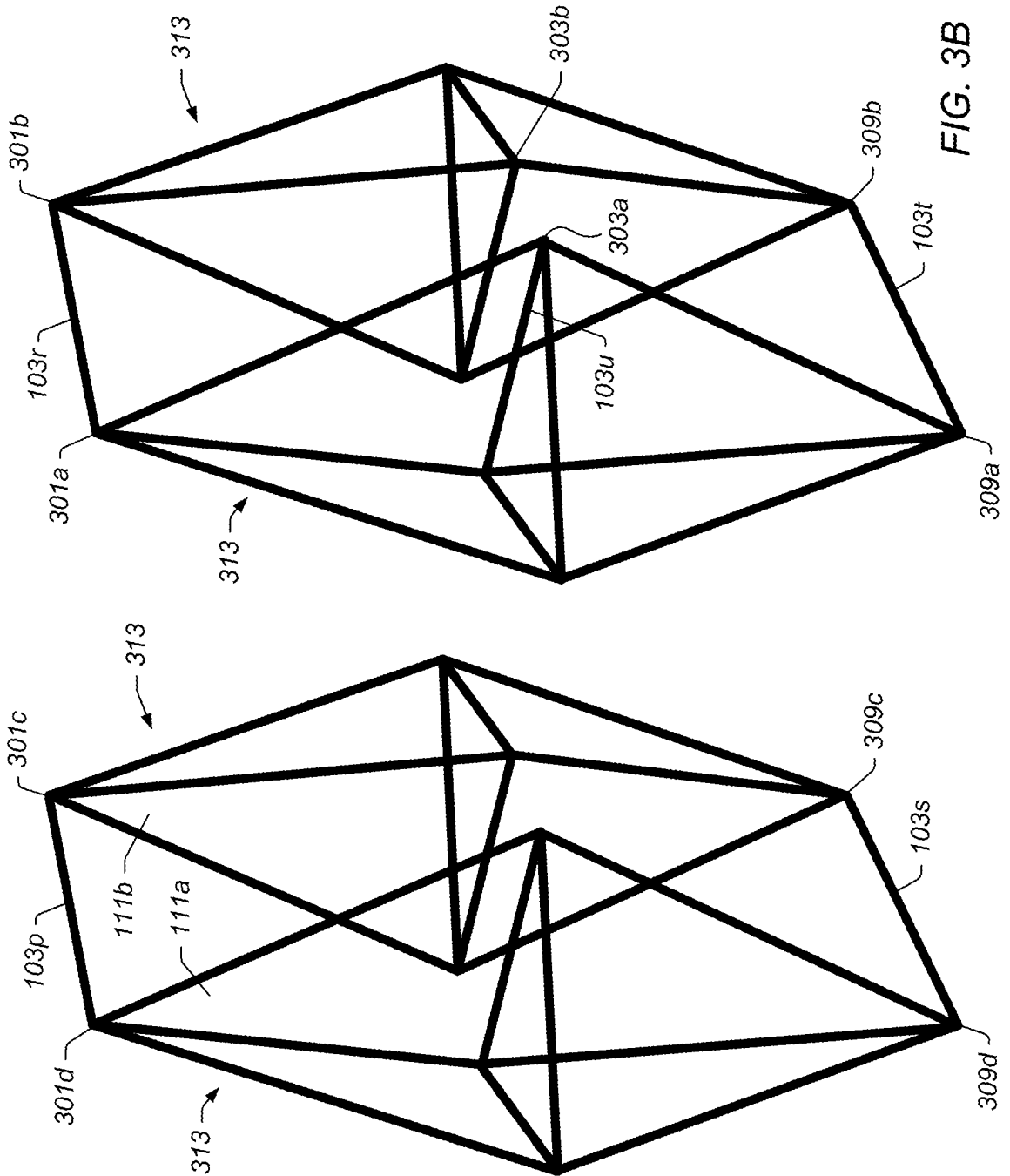

FIG. 3B

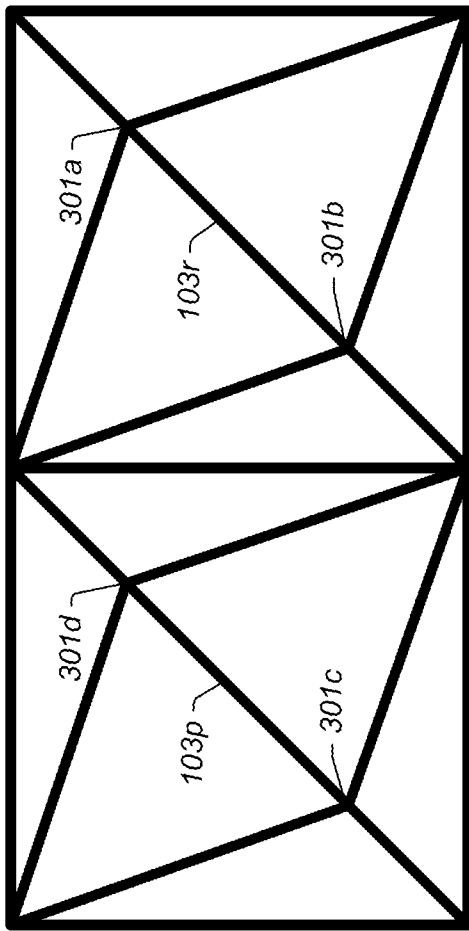

FIG. 4A

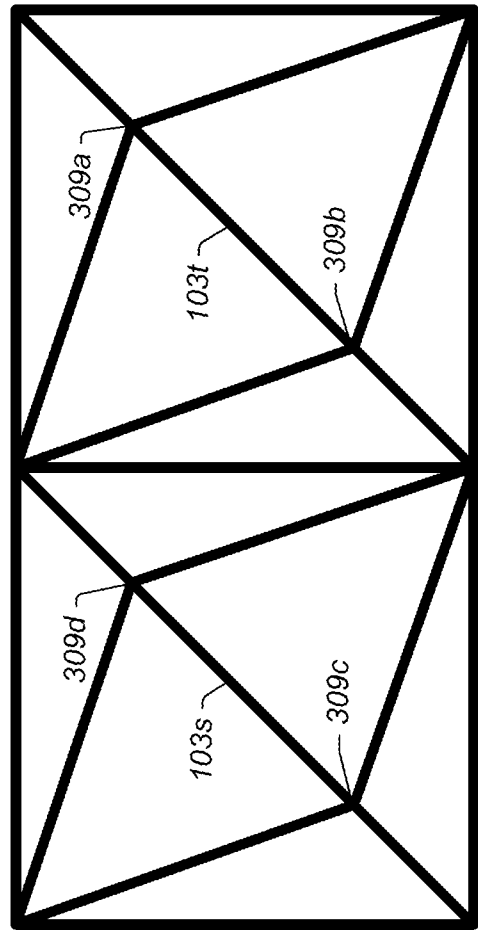

FIG. 4B

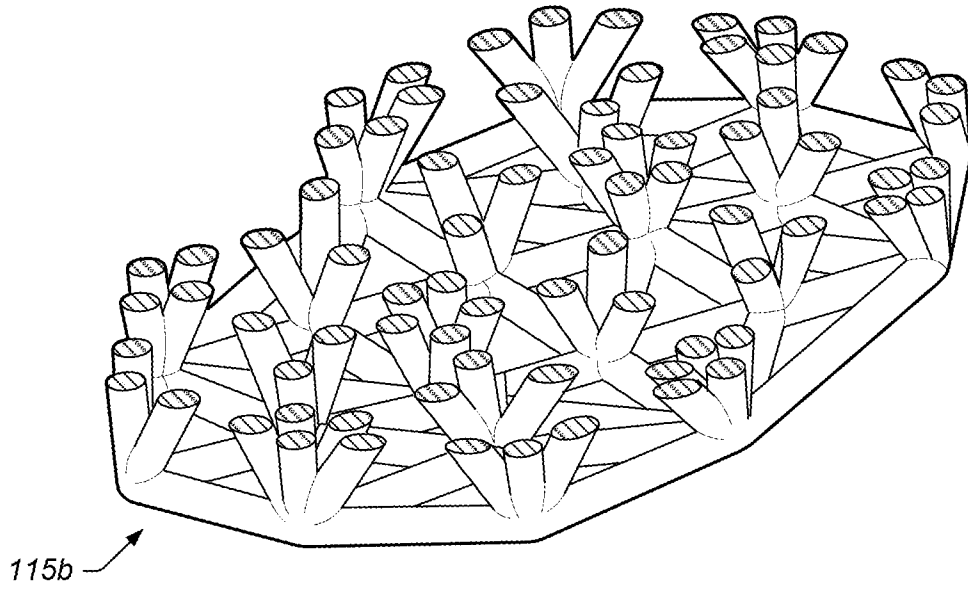

FIG. 5A

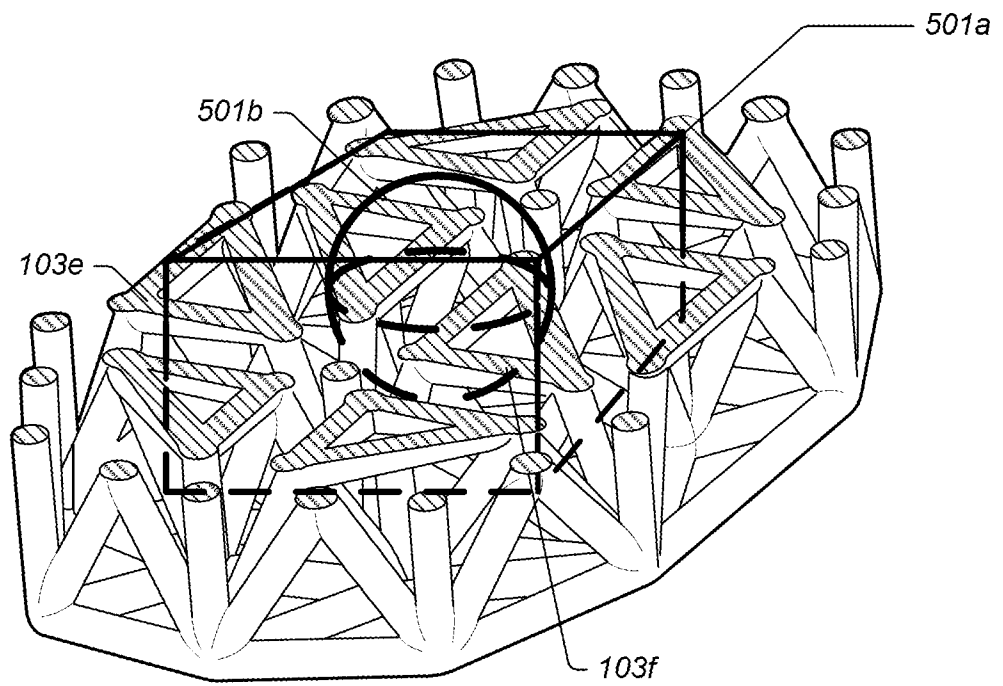

FIG. 5B

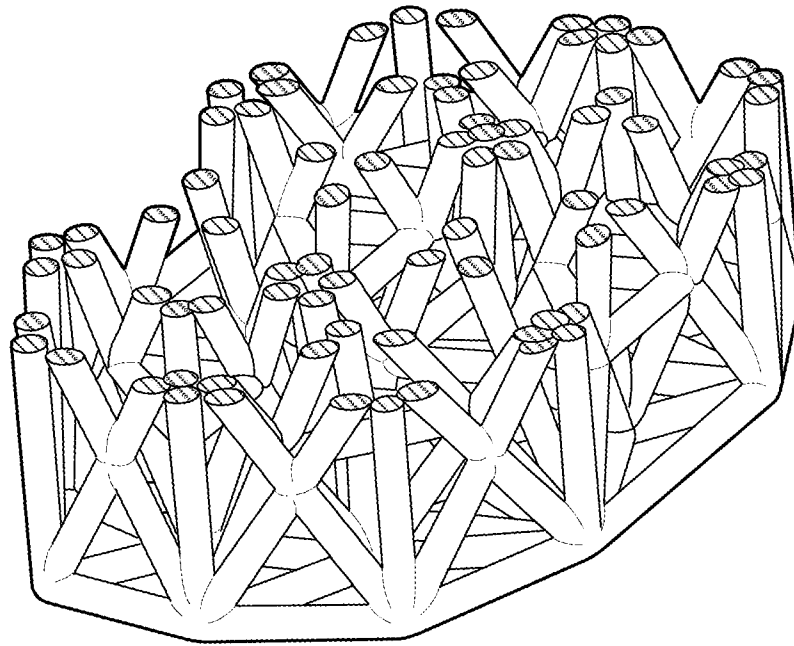

FIG. 5C

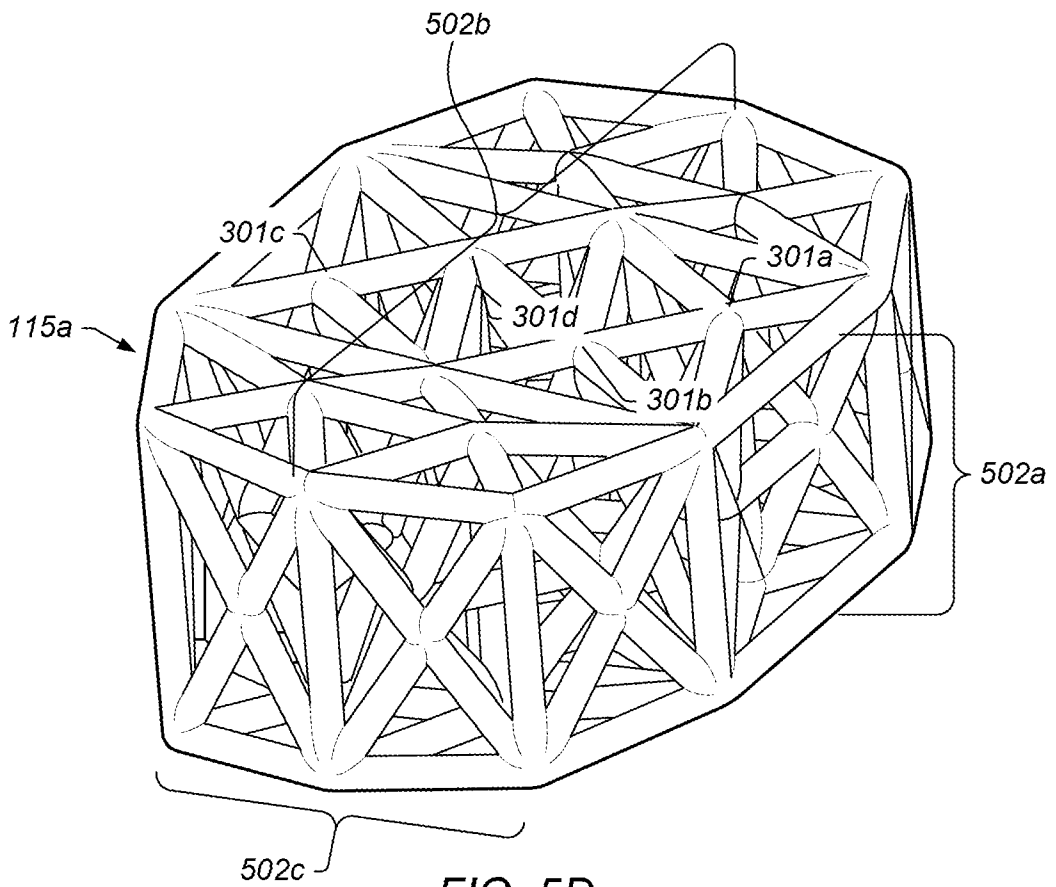

FIG. 5D

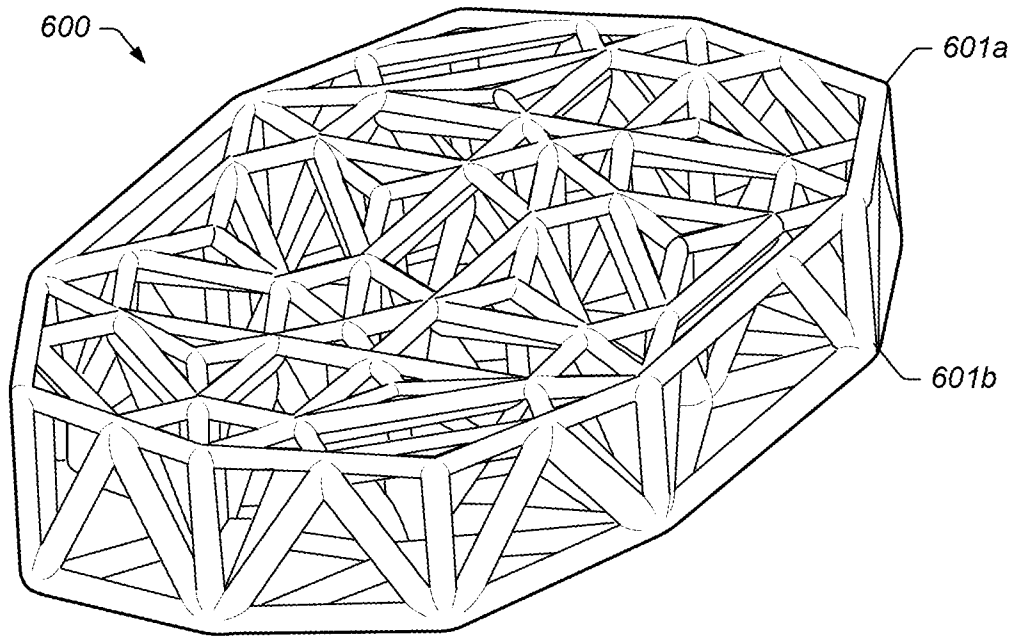

FIG. 6A

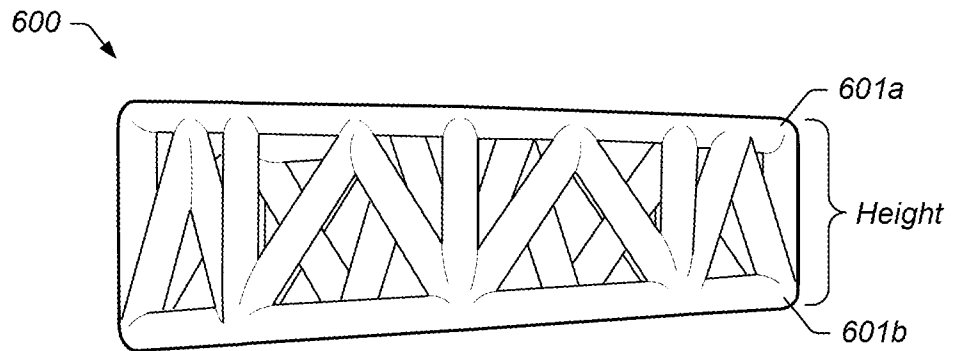

FIG. 6B

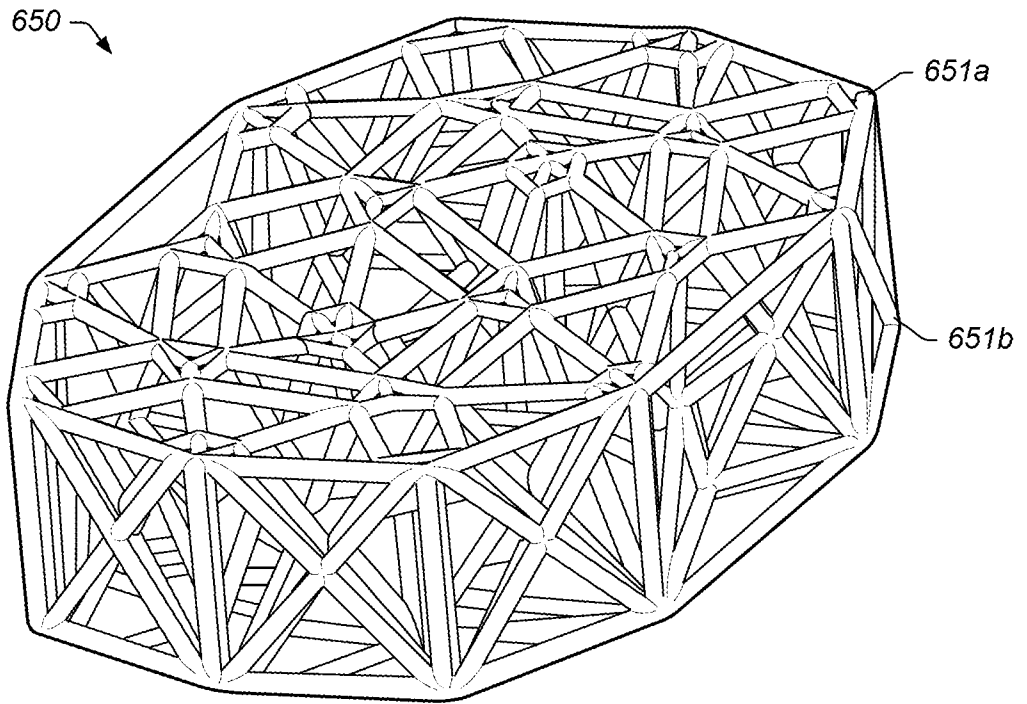

FIG. 6C

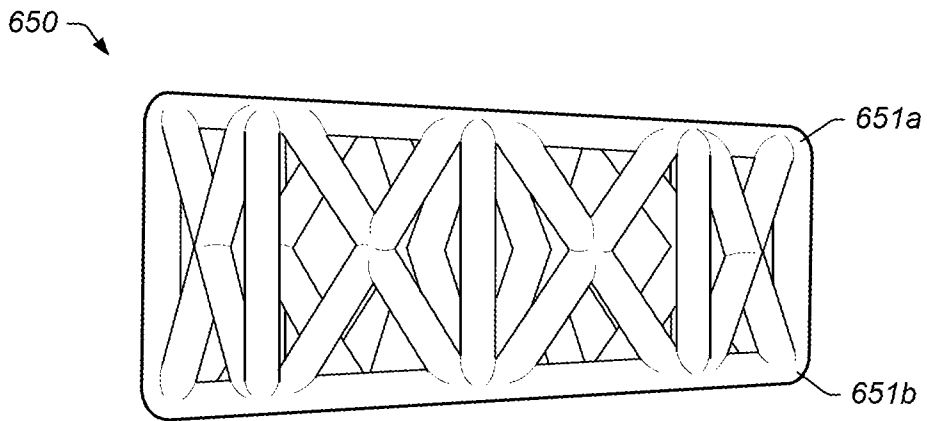

FIG. 6D

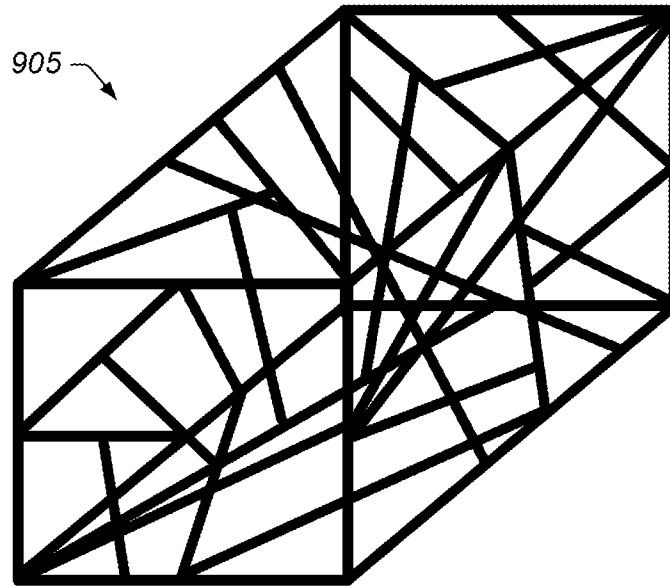

FIG. 7

14 / 17

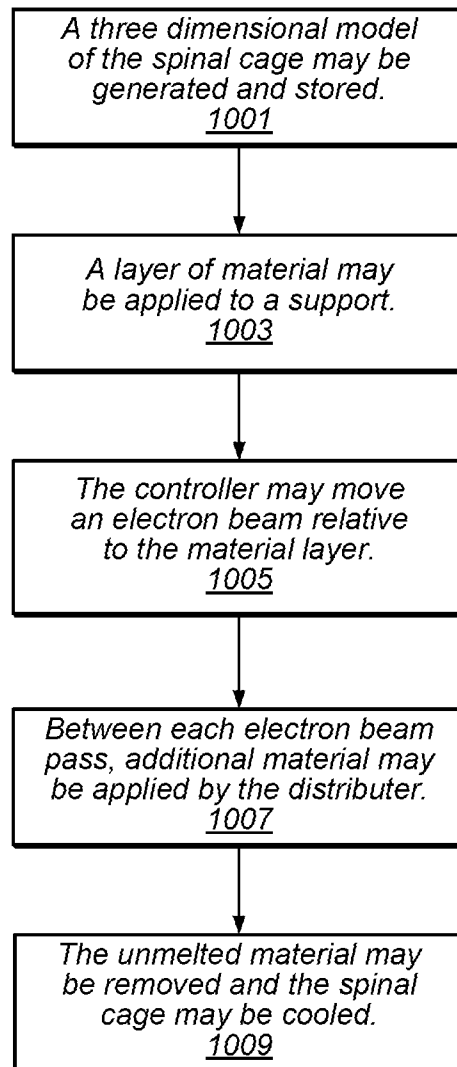

FIG. 8

15 / 17

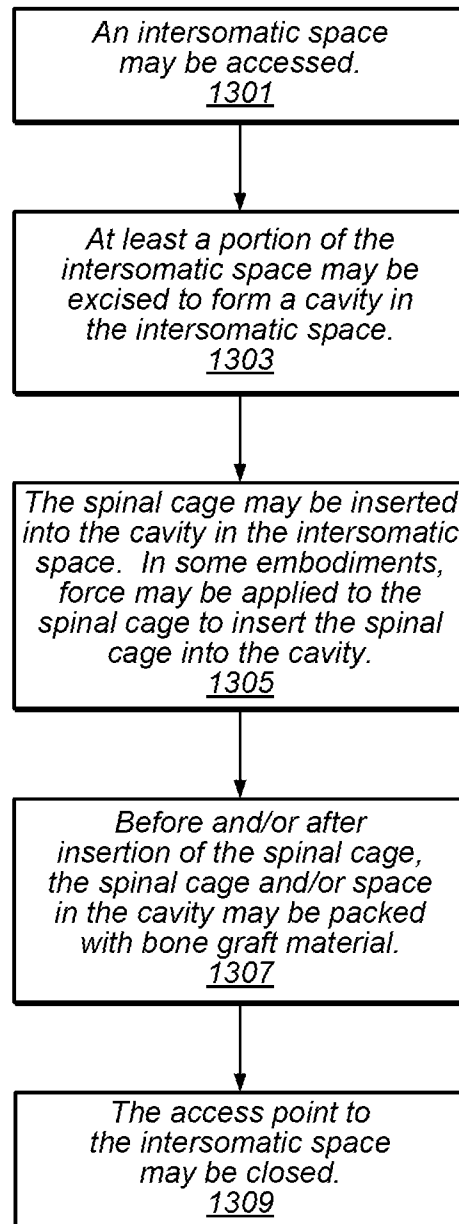

FIG. 9

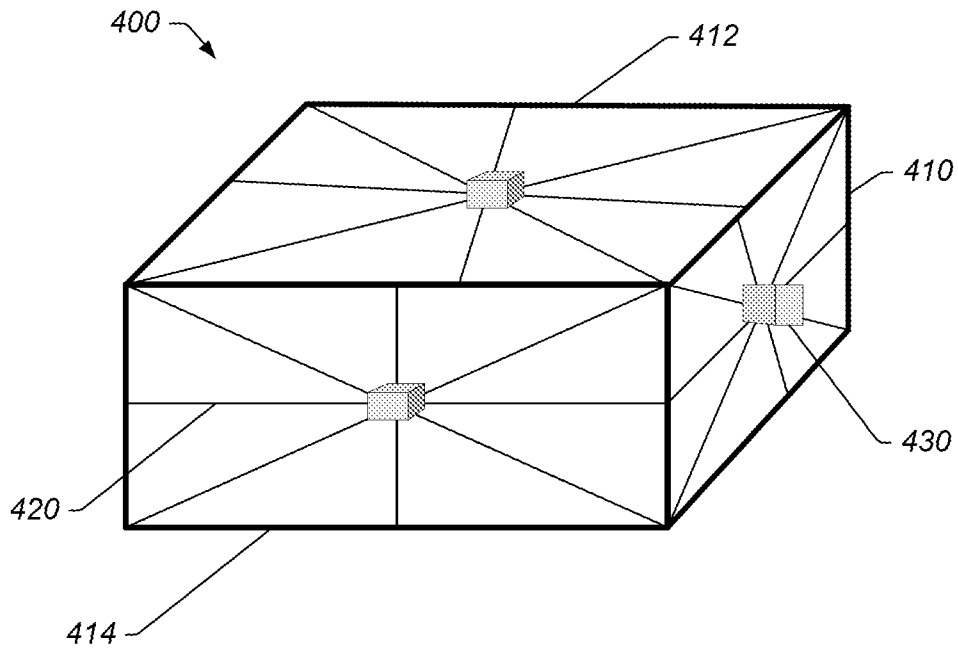

FIG. 10

17 / 17

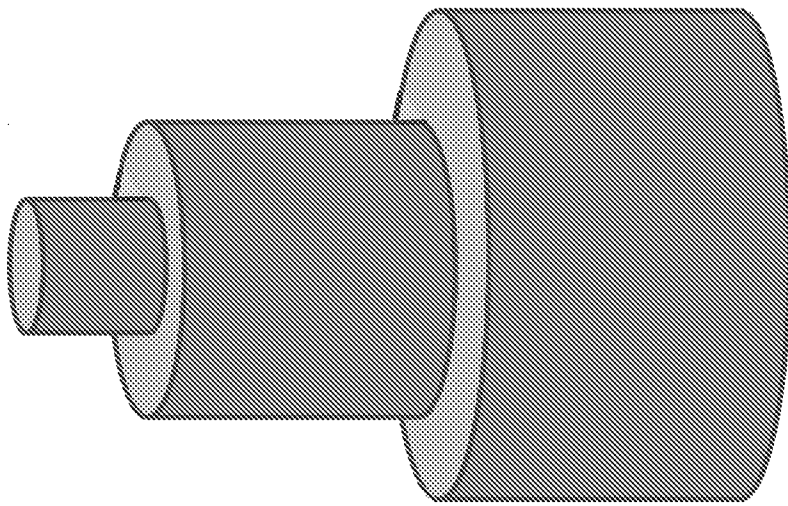

FIG. 11

INTERNATIONAL SEARCH REPORT

International application No.

PCT/US2014/030358

A. CLASSIFICATION OF SUBJECT MATTER IPC(8) - A61F 2/44 (2014.01) USPC - 623/17.11 According to International Patent Classification (IPC) or to both national classification and IPC												
B. FIELDS SEARCHED Minimum documentation searched (classification system followed by classification symbols) IPC(8) - A61F 2/28, 2/44, 2/90 (2014.01) USPC - 623/16.11, 17.11, 17.13, 17.16, 911, 923, 926 Documentation searched other than minimum documentation to the extent that such documents are included in the fields searched CPC - A61F 2/28, 2/44, 2/90 (2014.07) Electronic data base consulted during the international search (name of data base and, where practicable, search terms used) Orbit, Google Patents, Google												
C. DOCUMENTS CONSIDERED TO BE RELEVANT												
Category*	Citation of document, with indication, where appropriate, of the relevant passages	Relevant to claim No.										
X	US 2011/0196495 A1 (HUNT) 11 August 2011 (11.08.2011) entire document	1-3, 5-8, 10-18, 20-27										
A	US 6,206,924 B1 (TIMM) 27 March 2001 (27.03.2001) entire document	1-3, 5-8, 10-18, 20-27										
A	US 4,820,305 A (HARMS et al) 11 April 1989 (11.04.1989) entire document	1-3, 5-8, 10-18, 20-27										
A	US 2013/0030529 A1 (HUNT) 31 January 2013 (31.01.2013) entire document	1-3, 5-8, 10-18, 20-27										
<input type="checkbox"/> Further documents are listed in the continuation of Box C. <input type="checkbox"/>												
<p>* Special categories of cited documents:</p> <table border="0"> <tr> <td>"A" document defining the general state of the art which is not considered to be of particular relevance</td> <td>"T" later document published after the international filing date or priority date and not in conflict with the application but cited to understand the principle or theory underlying the invention</td> </tr> <tr> <td>"E" earlier application or patent but published on or after the international filing date</td> <td>"X" document of particular relevance; the claimed invention cannot be considered novel or cannot be considered to involve an inventive step when the document is taken alone</td> </tr> <tr> <td>"L" document which may throw doubts on priority claim(s) or which is cited to establish the publication date of another citation or other special reason (as specified)</td> <td>"Y" document of particular relevance; the claimed invention cannot be considered to involve an inventive step when the document is combined with one or more other such documents, such combination being obvious to a person skilled in the art</td> </tr> <tr> <td>"O" document referring to an oral disclosure, use, exhibition or other means</td> <td>"&" document member of the same patent family</td> </tr> <tr> <td>"P" document published prior to the international filing date but later than the priority date claimed</td> <td></td> </tr> </table>			"A" document defining the general state of the art which is not considered to be of particular relevance	"T" later document published after the international filing date or priority date and not in conflict with the application but cited to understand the principle or theory underlying the invention	"E" earlier application or patent but published on or after the international filing date	"X" document of particular relevance; the claimed invention cannot be considered novel or cannot be considered to involve an inventive step when the document is taken alone	"L" document which may throw doubts on priority claim(s) or which is cited to establish the publication date of another citation or other special reason (as specified)	"Y" document of particular relevance; the claimed invention cannot be considered to involve an inventive step when the document is combined with one or more other such documents, such combination being obvious to a person skilled in the art	"O" document referring to an oral disclosure, use, exhibition or other means	"&" document member of the same patent family	"P" document published prior to the international filing date but later than the priority date claimed	
"A" document defining the general state of the art which is not considered to be of particular relevance	"T" later document published after the international filing date or priority date and not in conflict with the application but cited to understand the principle or theory underlying the invention											
"E" earlier application or patent but published on or after the international filing date	"X" document of particular relevance; the claimed invention cannot be considered novel or cannot be considered to involve an inventive step when the document is taken alone											
"L" document which may throw doubts on priority claim(s) or which is cited to establish the publication date of another citation or other special reason (as specified)	"Y" document of particular relevance; the claimed invention cannot be considered to involve an inventive step when the document is combined with one or more other such documents, such combination being obvious to a person skilled in the art											
"O" document referring to an oral disclosure, use, exhibition or other means	"&" document member of the same patent family											
"P" document published prior to the international filing date but later than the priority date claimed												
Date of the actual completion of the international search		Date of mailing of the international search report										
04 August 2014		27 AUG 2014										
Name and mailing address of the ISA/US Mail Stop PCT, Attn: ISA/US, Commissioner for Patents P.O. Box 1450, Alexandria, Virginia 22313-1450 Facsimile No. 571-273-3201		Authorized officer: Blaine R. Copenheaver PCT Helpdesk: 571-272-4300 PCT OSP: 571-272-7774										

INTERNATIONAL SEARCH REPORT

International application No.

PCT/US2014/030358

Box No. II Observations where certain claims were found unsearchable (Continuation of item 2 of first sheet)

This international search report has not been established in respect of certain claims under Article 17(2)(a) for the following reasons:

- 1. Claims Nos.:
because they relate to subject matter not required to be searched by this Authority, namely:

- 2. Claims Nos.:
because they relate to parts of the international application that do not comply with the prescribed requirements to such an extent that no meaningful international search can be carried out, specifically:

- 3. Claims Nos.: 4, 9, 19, 28
because they are dependent claims and are not drafted in accordance with the second and third sentences of Rule 6.4(a).

Box No. III Observations where unity of invention is lacking (Continuation of item 3 of first sheet)

This International Searching Authority found multiple inventions in this international application, as follows:

- 1. As all required additional search fees were timely paid by the applicant, this international search report covers all searchable claims.
- 2. As all searchable claims could be searched without effort justifying additional fees, this Authority did not invite payment of additional fees.
- 3. As only some of the required additional search fees were timely paid by the applicant, this international search report covers only those claims for which fees were paid, specifically claims Nos.:

- 4. No required additional search fees were timely paid by the applicant. Consequently, this international search report is restricted to the invention first mentioned in the claims; it is covered by claims Nos.:

Remark on Protest

- The additional search fees were accompanied by the applicant's protest and, where applicable, the payment of a protest fee.
- The additional search fees were accompanied by the applicant's protest but the applicable protest fee was not paid within the time limit specified in the invitation.
- No protest accompanied the payment of additional search fees.