

(19) World Intellectual Property  
Organization  
International Bureau



(43) International Publication Date  
31 March 2005 (31.03.2005)

PCT

(10) International Publication Number  
WO 2005/028682 A1

- (51) International Patent Classification<sup>7</sup>: C14B 15/06 [DK/DK]; Hedegårdvej 13, Borbjerg, DK-7500 Holstebro (DK).
- (21) International Application Number: PCT/DK2004/000636
- (22) International Filing Date: 20 September 2004 (20.09.2004)
- (25) Filing Language: Danish
- (26) Publication Language: English
- (30) Priority Data: PA 200301373 19 September 2003 (19.09.2003) DK
- (71) Applicant (for all designated States except US): MAJ-GAARD INVEST APS [DK/DK]; Hedegårdvej 13, Borbjerg, DK-7500 Holstebro (DK).
- (72) Inventor; and
- (75) Inventor/Applicant (for US only): HEDEGAARD, Jens
- (74) Agent: DANSK MINK PAPIR A/S; Hedegaardvej 13, Borbjerg, DK-7500 Holstebro (DK).
- (81) Designated States (unless otherwise indicated, for every kind of national protection available): AE, AG, AL, AM, AT, AU, AZ, BA, BB, BG, BR, BW, BY, BZ, CA, CH, CN, CO, CR, CU, CZ, DE, DK, DM, DZ, EC, EE, EG, ES, FI, GB, GD, GE, GH, GM, HR, HU, ID, IL, IN, IS, JP, KE, KG, KP, KR, KZ, LC, LK, LR, LS, LT, LU, LV, MA, MD, MG, MK, MN, MW, MX, MZ, NA, NI, NO, NZ, OM, PG, PH, PL, PT, RO, RU, SC, SD, SE, SG, SK, SL, SY, TJ, TM, TN, TR, TT, TZ, UA, UG, US, UZ, VC, VN, YU, ZA, ZM, ZW.
- (84) Designated States (unless otherwise indicated, for every kind of regional protection available): ARIPO (BW, GH, GM, KE, LS, MW, MZ, NA, SD, SL, SZ, TZ, UG, ZM, ZW), Eurasian (AM, AZ, BY, KG, KZ, MD, RU, TJ, TM),

[Continued on next page]

(54) Title: METHOD AND MACHINE FOR NON-DESTRUCTIVE STRETCHING AND FASTENING OF A PELT ON A PELT BOARD

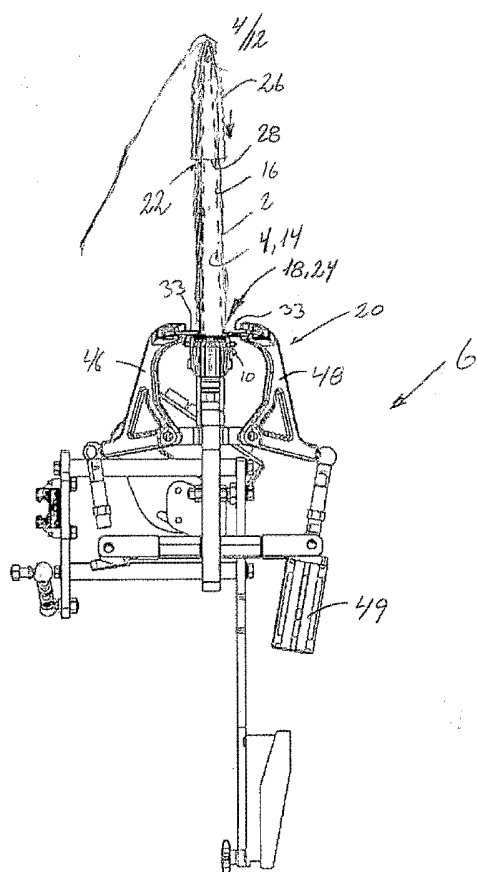

(57) Abstract: In connection with the non-destructive stretching and fastening of pelts (2) on distention elements/pelt boards (4), where the pelt is stretched and fastened in the stretched position during the drying process by means of a fixing bag, it has shown that the pelts give way (shrink) on each side of the tail root of the pelt, with the result that use is made of a number of staples for the fastening of these places on the stretched pelt. Since it is not at all desirable to use staples, a development of the distention elements/pelt boards (4) has taken place, so that these have an arched extent around two transverse axes in relation to their longitudinal axes. Moreover, it has long been desirable to be able to stretch the pelts to a greater degree, which has not been possible with the use of the known stretching machines. This development has led to the development of a method and a stretching machine for the execution of the method, where the gripping elements are configured to correspond with the shape of the distention element/pelt board, and where the pelt is engaged by the gripping elements along the whole of the lower periphery of the pelt, so that the counter-hold force in the pelt is distributed over the whole periphery of the pelt, whereby the pelt can be stretched to a greater degree without any damage to the pelt in the areas of engagement for the gripping elements.

WO 2005/028682 A1



European (AT, BE, BG, CH, CY, CZ, DE, DK, EE, ES, FI, FR, GB, GR, HU, IE, IT, LU, MC, NL, PL, PT, RO, SE, SI, SK, TR), OAPI (BF, BJ, CF, CG, CI, CM, GA, GN, GQ, GW, ML, MR, NE, SN, TD, TG).

— *before the expiration of the time limit for amending the claims and to be republished in the event of receipt of amendments*

**Published:**

— *with international search report*

*For two-letter codes and other abbreviations, refer to the "Guidance Notes on Codes and Abbreviations" appearing at the beginning of each regular issue of the PCT Gazette.*

**Title: Method and machine for non-destructive stretching and fastening of a pelt on a pelt board.**

The present invention relates to a method for the non-destructive stretching and fastening of pelts on a distension element/pelt board, for which there is used a machine of the kind which comprises holding means for engagement of the lower end of a relevant distension element/pelt board and gripping elements for securing the lower end of a pelt applied loosely on said distension element/pelt board during the stretching of the pelt on said board, where the distension element/pelt board is placed in the holding means, and where the gripping elements comprising inner parts and outer parts are brought into engagement with the pelt by the introduction of the inner parts between the surface of the distension element/pelt board and the leather side of the pelt, and the outer parts opposite the inner parts are displaced towards the fur side of the pelt for securing the pelt between the inner parts and the outer parts, and where the stretching takes place by effecting a displacement between the gripping elements and the holding means for the lower end of a relevant pelt board, and where an effective fastening of the pelt in the stretched position on the pelt board is established by the drawing of a holster-like bag (fixing bag) over the fur side of the pelt, which at least over a part of the lower end of the pelt (the tail end) is brought into tight contact with the fur side of the pelt, followed by a releasing of the gripping elements from the pelt and a releasing of the holding means from the distension element, and a stretching machine for the execution of the method.

In the drying of pelts, for example a mink or a fox pelt (in the following referred to jointly as a pelt), after skinning and scraping off the layer of fat on the leather side of the pelt, the pelts are stretched for example on a pelt board which is often first provided with a fat-absorbing material, the object being that during the drying of the pelt the fat remaining on the leather side of the pelt will be drawn into the paper and hereby removed from the pelt.

In the following there are provided some definitions which will be used in the following:

In the following, the mounting of pelts is to be understood as a procedure which consists of the drawing of a pelt over a pelt board, preferably with the leather side of the pelt facing towards the surface of the board, the stretching of the pelt on the pelt board and the fastening/securing of the pelt in the stretched position on the  
5 pelt board.

The use of pelt boards in connection with the drying of pelts is thus well-known, and with the passing of time a great number of configurations of such pelt boards has been developed with the view of improving the drying of pelts. With the  
10 mechanisation and organising of production and sale of pelts which has taken place, there has also occurred a certain standardisation of pelt sizes, and herewith also of the pelt boards on which the pelts are stretched and fixed in this position during the drying, the object being to be able to achieve the best possible and uniform pelt quality, which means that the producers can obtain a higher price for  
15 the pelts.

Those pelt boards which have become most widespread, and which today are used by the majority of the producers of pelts, including in particular mink pelts, are made of wood, and can briefly be described as a flat piece of wood with a first  
20 broadside surface and a second broadside surface, and a first narrow side surface and a second narrow side surface, the breadth of which is essentially considerably less than the breadth of the broad side surface, and where the one end of the board (the foot end) is cut off at right-angles to the longitudinal axis of the board, and the lower end nearest the foot end has constant breadth, but hereafter this  
25 breadth gradually decreases towards a pointed but rounded end part (the front end, the nose end), and where the pelt board has a through-going slot between the first broadside surface and the second broadside surface, said slot lying symmetrically around the longitudinal axis of the board and extending between near the pointed end part and at least for over a half of the length of the board.  
30 The pelt board described above is a pelt board intended for the pelts from male animals, which are normally larger than the pelts from female animals. A pelt board intended for use in the drying of the leather side of pelts from female animals does not comprise a lower end where the breadth of the board is constant.

The "nose end" of the pelt shall be understood to be that part of the pelt which previously covered the cranium of the furred animal, and in connection with the mounting of the pelt is that part of the pelt which is placed in/over the pointed but rounded end of the board, which can randomly be referred to as the front end or  
5 the nose end of a pelt board.

The "tail end" of the pelt shall be understood as that end of the pelt where the tail sits firmly and from where the tail extends from the lower edge of the back, and which collectively can denote the whole circumference of the pelt in said area. In  
10 the mounting of the pelt, the tail end of the pelt is always placed nearest the foot end of the board.

The lower end of the back of the pelt shall be understood to be that part on both sides of the area where the tail extends from the lower edge of the back of the  
15 pelt.

The belly side of the pelt shall be understood to be that side of the pelt where the forelegs and thighs are placed.

20 In the following, a "mounted" pelt shall be understood to be a pelt drawn onto a pelt board where it is stretched and fixed in this position on the board.

In the following, the removal of the pelt from the pelt board, typically after the conclusion of the drying process, is to be understood as the removal of a pelt  
25 which has been stretched and fixed in this position on the board during the drying process. The procedure for removal also includes the removal of any elements which may have been used for the fixing of the pelt in the stretched position on the pelt board.

30 In certain cases, the fat-absorbing material which is placed on the board before the drawing-on of the pelt consists of a bag made of fat-absorbing material, preferably of fat-absorbing paper with perforations, for example in the form of a so-called "pelt bag", which will thus be lying between the pelt board and the leather side of the pelt.

The drying procedure or drying of pelts shall be understood to be a drying-out of the leather side of the pelt to a preferred extent which from experience excludes oxidation and the attack on the pelt by mites. The drying process is typically  
5 effected by the blowing of dry air in the slot in the board via pipes which are introduced into the slot, where via the perforations in the walls of the pelt bag the dry air is diffused out to the leather side of the pelt and dries the pelt.

In the drawing of the pelt on to the pelt board, a stretching of the pelt is often  
10 effected mechanically in order to achieve the greatest possible length of the pelts, and herewith the highest obtainable price at the fur auction.

The hitherto most used method of mounting a pelt is that of manually drawing the pelt over the pelt board with the leather side facing the board, which is hereafter  
15 inserted into a machine comprising holding means for fastening of the board's lower end, which extends below that part of the board which is covered by the pelt, i.e. after the pelt has been stretched on the board by the machine. Hereafter, the gripping elements are inserted into engagement between the leather side and the fur side of the pelt on the back and the belly side respectively, after which the pelt  
20 is stretched out on the board by a relative displacement between the gripping elements and the board, after which the pelt is fastened in the stretched position on the board by the insertion of staples/clips which penetrate the pelt and are anchored in the board itself.

25 Hereafter, the pelt is dried while stretched on the board, which gives rise to elongated holes in the pelt from the clips/staples which secure the pelt to the board. The result is that said holes, which appear both in the back of the pelt, which is the most valuable part of the pelt, as well as the belly part, make the pelt in these areas worthless, in that this part of the pelt with the holes can not be used  
30 in the further processing of the pelt. Thus the placing of the clips/staples so close to the under edges of the pelt, without the pelt drawing itself free of the clips during the drying with further damage to the pelt, is important. Stretching machines have been developed for this purpose, which are known from DK 169525, which discloses a stretching machine comprising gripping elements and sensors which

control the extent of the stretching of the pelt on the board, so that the optimal stapling can take place without tearing out of the staples.

5 In the removal of the pelt from the board, the stapling of the pelts gives rise to the need for manual labour to a not inconsiderable degree in connection with the removal of said staples, in that the removal of these must take place without any further damage to the pelt. Finally, the use of staples/clips for the fixing of the pelt results in damage to the material of which the board is made, which is most often wood, so that after a time these must be replaced.

10

The ideal method for stretching and drying of the pelt will thus involve being able to fix the pelt in the stretched position without the use of staples. From WO-A1-0162985 there is known a method and a fixing bag for fixing of the pelt in the stretched position during the drying, whereby after the pelt has been stretched on  
15 the board a bag is drawn over the fur side of the pelt, the inside dimensions of said bag being such that the outwardly-directed forces of the fur side of the pelt press the leather side of the pelt so much against the board that the pelt is hereby secured in the stretched position, without the use of staples which penetrate both the pelt and the board. The above-mentioned reduction in the value of the pelt as  
20 a result of holes is hereby avoided, which means that it will be possible to achieve an appreciably higher price for the pelt.

From DK 2000 01174L there is known a method and machine for the stretching of pelts, where the machine is arranged with gripping elements in a manner which  
25 enables a fixing bag to be drawn over a pelt which is stretched on a traditional board by the machine, where the holding elements comprise flat beak-shaped holding elements which respectively grip the back part and the belly part (the leg side) of the pelt from below, which means that the fixing bag can be drawn over the pelt to a level below the lower edge of the back part.

30

However, practical use of this method has shown that the pelt shrinks on each side of the tail root during the drying, which often results in a reduced price for the pelts as a consequence of the pelt not having the expected size after the processing. The reason for this is partly that the fixing bag can not exert enough

pressure against the fur side of the broad sides of the pelt for sufficient friction to arise between the surface of the board and the leather side of the pelt to counteract the slipping of the above-mentioned sides of the pelt. The result is that use is still made of a smaller number of staples for the fixing of said slipping parts  
5 of the pelts during the drying process, the reason being that the price reduction per pelt at a lower size category is greater than the price reduction for the few holes left in the pelt by the staples.

A solution to this problem could be to stretch the pelts somewhat longer on the  
10 boards, but the known pelt machines do not offer adequate facilities for a preferred stretching of the pelt on the boards, where with the holding elements of the known pelt machines a counter-hold is established during the stretching of the pelts along two relatively narrow engagement surfaces on the one or on each flat side of the pelt, with the result that if the pelts are stretched to a greater degree, they will be  
15 damaged in the holding areas, which are also the most valuable parts.

In the meantime, a further development has taken place of the distension elements/pelt boards which are used in connection with the stretching, fixing and drying of pelts, so that it is possible to achieve an effective fixing of the pelt during  
20 the drying process without shrinking/slipping of parts of the pelt's lower ends. Roughly speaking, the further development consists of configuring the broad sides of the distension elements/boards in an arched/concave manner in relation to the centre axis of the board, whereby a better counter-hold force is achieved on the areas of the stretched pelt, which experience has shown will give way when use is  
25 made of the traditional boards. Said configuration of the boards has thus made it possible to fix the pelt in the stretched position on a pelt board during the drying without the use of staples which leave holes in the pelt.

However, said further development of the boards has meant that the known  
30 stretching machines, which are intended for use together with the traditional boards described above, which consist of a planed board of pinewood with two opposing broad side surfaces and two narrow side surfaces, are not usable. Moreover, there has further been a wish to be able to carry out a stretching of the

pelts to a degree which is greater than has traditionally been possible, cf. the problems described above.

The object of the invention is thus to provide a method for non-destructive stretching and fastening of pelts which allows the pelt to be fastened on the board by the use of a holding/fixing bag, which sits tightly around the fur side of the pelt in an area around the lower end, and which also makes it possible to stretch the pelt on the board to a greater degree than that which has hitherto been possible to achieve, without any damage to the pelts in the holding area in the lower end (the tail end) of the pelt.

This object is achieved by a method for the non-destructive stretching and fastening of pelts on a distension element/pelt board, for which use is made of a stretching machine of the kind which comprises holding means for engaging the lower end of a relevant distension element/pelt board, and gripping elements for securing the lower end of a pelt drawn loosely on said distension element/pelt board during the stretching of the pelt on the distension element/pelt board, where the distension element is placed in holding means and where the gripping elements comprising inner parts and outer parts are brought into engagement with the pelt by the insertion of the inner parts between the surface of the distension element/pelt board and the leather side of the pelt, and where the outer parts outside the inner parts are displaced towards the fur side of the pelt for the fastening of the pelt between the inner parts and the outer parts, where the stretching takes place by effecting a displacement between the gripping elements and the holding means for the lower end of a relevant pelt board, and where an effective fastening of the pelt in the stretched position on the distension element/pelt board is established by the drawing of a fixing bag over the outside of the fur side of the pelt, which at least over a part of the pelt's lower end (the tail end) is brought into tight contact with the fur side of the pelt, followed by a releasing of the gripping elements from the pelt and a releasing of the holding means from the distension element, is characterised in that the gripping elements engage and fasten the pelt substantially along the whole periphery of the pelt.

The very central and new and very important aspect of the method according to the invention is that the lower end (the tail end) of the pelt is engaged by the gripping elements along the whole periphery of the pelt, which results in an even distribution of the holding forces for fastening the pelt's lower end (the tail end), in that the holding forces are hereby distributed over the whole of the periphery of the pelt during the drying process, which is effected by a relative displacement between the distension element/pelt board and the gripping elements. Moreover, this also results in the pelt being stretched uniformly over the whole of its periphery, and consequently it will be possible to effect a stretching of the pelt to a degree which has not hitherto been possible, and this without damaging the pelt in the area of engagement for the gripping elements, whereas the method hitherto used with pelt boards comprising plate-shaped or beak-shaped gripping elements respectively engage locally in the rear part and the leg part over a considerably smaller extent than is the case with the method according to the invention. This means that with the use of one of the known stretching machines, if attempts are made to stretch the pelt to the extent possible with the method according to the invention, both the belly part as well as the lower end of the back part of the pelt will be damaged or ruined, with the consequent reduction of the price for the relevant pelt which can be obtained by the fur farmer.

20

Moreover, it is realised that during the relative displacement between the holding means for the pelt board and the gripping means, it is possible to carry out a further stretching of the pelt by imparting a vibratory movement to said holding means and/or the gripping means which is oriented mainly in the longitudinal direction of the distension element/pelt board. In this connection it shall be mentioned that the imparting of said vibratory movement is known from WO 02 44428 A1, but the combinations of the method according to the present invention and that known from WO 02 44428 A1 are new, and by being able to achieve a further stretching of the pelts by combining that which is known from WO 02/44428 A1 with the method and the pelt board according to the invention, the increase in the value of the pelts is considerable.

30

This means that by the method according to the invention, where the pelt is fastened along the whole periphery at the tail end, and where a greater traction

can therefore be exercised in the pelt during the stretching, in combination with the imparting of a vibratory movement, which also affords the possibility for increased stretching of the pelt, and whereby with the imparting of the vibratory movement it is stretched practically speaking over the whole length of the pelt, and not just in the lowermost third part, as is the case with the traditionally known method, hitherto unknown pelt lengths can be achieved without damage to the pelts.

Thus with the method according to the invention, the possibility is provided of being able to carry out the stretching of pelts from furred animals on distension elements/pelt boards to an extent which is hitherto unknown, which in many cases will provide the possibility of being able to stretch the pelts to a whole size category over that which is possible by use of the known method, where counterhold is established in the pelt's belly part and back part along two relatively narrow areas of engagement on each flat side of the board.

15

A stretching machine for use in the execution of the method disclosed in claim 1, and comprising holding means for a distension element/pelt board, operable gripping elements for engaging/fastening of the lower end of a pelt drawn loosely on the distension element/pelt board, and means for carrying out a relative displacement between the distension element/pelt board and the gripping elements, and where the gripping elements comprise at least two inner parts which are inserted in between the surface of the distension element/pelt board and the leather side of the pelt from the lower end of the board, and cooperating with the inner parts at least two outer parts with opposing sides which stand in connection with guiding and pressure means for displacement of the outer parts between a closed position where the outer parts are pressed into contact with the fur side of the pelt for fastening of the lower end of the pelt, and an open position where the pelt is free, is characterised in that the sides of the inner parts and the outer parts facing towards the distension element/pelt board are configured to match the external shape of the distension element/pelt board, so that the gripping elements engage the lower end of the pelt substantially along the whole of the external periphery of the distension element/pelt board.

20  
25  
30

By arranging the gripping elements in such a manner that these can engage and fasten the lower end of the pelt along the whole of its lower periphery, there is thus achieved the possibility of being able to distribute the holding forces during the stretching of the pelt on a distension element/pelt board along the whole of said periphery of the pelt/distension element, the result being that when stretched in the stretching machine, the pelt is stretched uniformly over the whole of its periphery, and the possibility is also provided of being able to exercise a greater traction on the pelt, which provides the possibility of stretching the pelt to a size category which lies above that which is normal. This possibility provides greater earning potential for the fur farmers, who hereby obtain a higher price for pelts delivered to the fur auctions. Moreover, the increased stretching of the pelts will result in lower weight of the pelts which are used for finished fur products, which is preferred by the users of these products.

With the view of further improving the stretching of a pelt placed on a distension element/pelt board, on the holding means and/or gripping means of the stretching machine there can be mounted an operable vibrator unit with a vibration amplitude oriented substantially in the longitudinal direction of the distension element/pelt board. There is hereby carried out a stretching of practically the whole of the pelt, unlike with the traditional method where approx. between 1/3 and a half part of the lower end of the pelt is stretched. Combined with the increased traction which is now possible with the machine according to the invention, where the special construction of the gripping elements makes it possible to distribute the tractive forces along the whole periphery of the pelt, there will thus be the possibility of achieving a considerable increase in the value of the pelts which are stretched and fastened in the stretched position by the method and the machine according to the invention.

With the view of achieving an improved holding force between the inner parts and the outer parts, the inner parts can comprise an upper counter-hold flange, the edge of which facing away from the distension element comprises a track, and the sides of the outer parts facing towards the upper edge comprising a pressure flange cooperating with the track and having an edge with a shape which corresponds to the shape of the track.

By the clamping of the lower peripheral edge of the pelt between the counter-hold flange and the edge of the pressure flange, there will hereby be established a peripheral and, in relation to the direction of the relative displacement between the holding means for the distension element/pelt board and the gripping means, a transversely-directed counter-hold edge, which provides the possibility of reducing the pressure between the pressure flange and the counter-hold flange, and the size of the pressure means which exercise this pressure can herewith be reduced, and herewith also the energy which is used to establish this pressure.

10

A preferred embodiment of the stretching machine is further characterised in that the inner parts of the gripping elements consist of two similarly-shaped, open but laterally reversed half parts which are displaceable towards each other, and which are mounted on respective brackets, which by a pivot connection are disposed opposite each other, said brackets being displaceable via actuators towards each other and away from each other, between a closed position where the subtending end parts of the inner parts are more or less in contact with each other, and an open position where the inner parts are lying at a distance from each other, and where the outer parts are placed on pivotal arms for the respective brackets, said arms being displaceable with actuators between a position where the flange edges are pressed against the tracks in the upper edge of the inner parts, and a position where said flange edges are lying at a distance from said tracks.

20

With the disclosed construction of the gripping elements, good possibilities are thus achieved for the placing of a distension element/pelt board between the inner parts, since at the same time as these parts are displaced to the open position, there occurs a corresponding displacement of the outer parts, which are disposed pair-wise on the same brackets as the inner parts.

25

Without renouncing other embodiments, it can be mentioned that in a specially preferred embodiment of the inner parts of the gripping elements, which are intended for the fastening of pelts on distension elements/pelt boards having broad sides which are arched/concave in relation to the centre axis of the board, the subtending sides of the inner parts can extend in a concave manner.

30

It is hereby achieved that the pelt is gripped substantially along the whole periphery of the pelt along the sides of the distension element.

5 With a view to ensuring good possibilities for the placing of the fixing bag which is drawn over the fur side of the pelt for fastening of the pelt in the stretched position, the counter-hold flanges can stand upright from a plane part which is oriented in a substantially transverse manner in relation to the extent of the counter-hold flanges.

10

With the method and the apparatus for the execution of the method, there is thus provided the possibility of carrying out the stretching and fastening of a pelt by use of newly-developed distension elements/pelt boards in a staple-free manner, which at the same time opens possibilities for the stretching of the pelt to a hitherto  
15 unknown degree, without the pelt being damaged in the areas of engagement for the gripping elements.

In the following, the invention is explained in more detail with reference to the drawing, where

20

Fig. 1 is a perspective view of a stretching machine for the execution of the method according to the invention.

Fig. 2 is a perspective view of a section of the machine shown in fig. 1, around the machine's gripping elements according to the invention.

25 Fig. 3 shows a perspective view of the one half part of the gripping elements shown in fig. 2.

Fig. 4 is a side view of the gripping elements shown in fig. 3.

Fig. 5 is a plan view of the gripping elements shown in fig. 2.

Fig. 6 is a perspective view of the gripping elements shown in fig. 2, seen in the  
30 open position.

Fig. 7 shows the gripping elements shown in fig. 6, seen from the side.

Fig. 8 shows the same as in fig. 6 and fig.7, seen from above.

Fig. 9 is a perspective view of the gripping elements shown in fig. 2, seen in the closed position.

Fig. 10 shows the gripping elements shown in fig. 9, seen from the side.

Fig. 11 shows the same as in fig. 10, seen from above, and

Fig. 12 is a perspective view of a section of the gripping elements shown in fig.9.

5 In fig. 1 there is shown a perspective view of a stretching machine 6 for the execution of the method according to the invention. The machine 6 comprises holding means 8 for engaging/fastening of the lower end 24 of a pelt board 4 (not shown), said holding means in the shown embodiment of the machine 6 being placed on a U-shaped bracket plate 100 which is housed in a displaceable manner  
10 in a guide rail 102. The displacement of the bracket plate 100 and herewith of the holding means 8 in the direction of the guide rail takes place via a not-shown actuator, which typically comprises a pneumatic plunger (not shown). The machine 6 further comprises gripping elements 12 disposed at a level over the holding means 8, and whose positioning is framed in with a circle with the reference  
15 number 12.

Fig. 2, which is perspective view of a detail section of the machine shown in fig. 1, shows the gripping elements 12.

20 In fig. 3 is shown a perspective view of the one half part of the gripping elements 12 shown in fig. 2.

In fig. 4, which is side view of the gripping elements 12 shown in fig. 2 in the machine 6 shown in fig. 1, it is indicated how a distension element/pelt board 4 onto which a pelt 2 has been drawn is disposed between the gripping elements 12.  
25 Fig. 4 also indicates the surface 14 of the distension element/pelt board 4, the fur side 22 of the pelt, a fixing bag 26 intended for the fixing of the pelt 2 in the stretched position on the board 4, showing the lower ends 28 of the bag, which after the pelt has been stretched on the distension element 4 by means of the machine 6 and fastened in this position, is intended for a further drawing-on so  
30 that the bag's lower end is placed in the area at the tail end 18 of the pelt, where in an area around the pelt's tail end it will sit tightly around the fur side 22 of the pelt, and hereby press the leather side 16 of the pelt against the surface 14 of the distension element/pelt board, whereby sufficient friction is created to fasten the

pelt in its stretched position during the consequent drying of the leather side 16 of the pelt. Fig. 4 also indicates where the lower end 24 of the pelt board is placed and the lower end (the tail end) 18 of the pelt. Fig. 4 also shows actuators 49 with pivotally mounted arms 46, 48 on which outer parts 20 of the gripping elements 12 are placed.

In fig. 5, which is a plan view of the gripping elements 12 shown in fig. 4, it is seen how the distension element/pelt board 4 with pelt 2 is placed in relation to the inner parts 10 and outer parts 20 of the gripping elements 12, again showing the distension element/pelt board 4, and how the leather side 16 of the pelt is in contact with the surface 14 of the distension element/pelt board 4.

As will appear from fig. 6, fig. 7 and fig. 8 and elsewhere, the gripping elements 12 comprise inner parts 10 and outer parts 20. The inner parts 10 of the gripping elements 12 consist of open but laterally reversed half parts 34, 36 which are displaceable towards each other, and which extend in an arched manner. The half parts 34, 36 are mounted on respective brackets 38 which by a pivot connection 39 are disposed opposite each other, and via actuators 40 said brackets 38 are displaceable towards and away from each other between a closed position, where the subtending end parts 42, 44 of the inner parts 10 are more or less in contact with each other and with the surface 14 of the distension element/pelt board 4, and an open position where the inner parts 10 are lying at a distance from each other. The outer parts 20 are placed on the respective brackets 38 by pivotally mounted arms 46, 48, said arms 46, 48 being displaceable via actuators 49 between a position where the flange edges 33 are pressed against track 32 in the upper edge 28 of the inner parts 10, cf. fig. 10 and fig. 12, and a position where said flange edges 33 are lying at a distance from said track 32.

As further appears from fig. 11, in the shown embodiment the subtending sides 50 of the inner parts 10 extend in a concave manner, which is suitable for a distension element /pelt board 4 with broad sides which are arched/concave in relation to the board's centre axis in at least two directions. It shall be mentioned that the inner parts 10 and the outer parts 20 can be of other configurations, corresponding with distension elements/pelt boards with cross-sectional shapes

other than that shown here. For example, the subtending sides can be configured to accommodate boards with rectangular cross-section.

As further appears from fig. 11, but more clearly in fig. 6, the counter-hold flanges 27 stand upright from a plane part 52 which is oriented in a substantially transverse manner in relation to the extent of the counter-hold flanges. This offers the advantage that the lower end 24 of the pelt will be retained on the plane part 52 during the introduction of the counter-hold flanges 27 between the surface/outer side 14 of the distension element and the leather side 16 of the pelt.

10

In fig. 9, fig. 10 and fig. 11, the gripping elements 12 are shown in the closed position, so that that the edges 35 are lying in the tracks 32 in the counter-hold flange 27. Namely in fig. 12, which is a sectional view of the gripping elements 12, it is seen how the shape of the tracks 32 in the counter-hold flange 27 and the edges 35 of the pressure flanges 33 on the outer parts 20 match one another. I.e. with the gripping elements in the closed position, where the lower end 24 of a pelt is clamped between the track 32 and the edge 35 of the pressure flange, there is formed a transversely-directed edge over which the pelt is fastened by the gripping elements, which results in a very effective fastening during the stretching of the pelt on the distension element/pelt board 4.

20

Moreover, the inner parts 10 and the outer parts 20 are configured in such a manner that in the closed position of the gripping elements, these allow a fixing bag to be led down over a pelt stretched on the distension element/pelt board, which is achieved by the combination of the pressure flanges 33 and the tracks 32 in the upper edge of the inner parts' counter-hold flange 27.

25

With the invention there is thus provided a method and a machine for the mechanical, non-destructive stretching and fastening of pelts, by the drawing-on of a fixing bag to a level lying below the lower edge of the pelt in the stretched condition, the result being that there is no need for a further fastening of the pelt on the pelt board, whereby the use of staples which penetrate the pelt and the pelt board is rendered superfluous. Moreover, with the configuration of the machine 6, and namely its gripping elements 12, the shape of which corresponds to the

30

geometry of the distension element, including that the gripping elements 12 engage the lower end 24 of the pelt along practically the whole of its periphery, the possibility is achieved of being able to stretch the pelts to a hitherto unknown extent, without the pelt being damaged in the area of engagement of the gripping elements, the reason being that the tractive forces in the holding/engagement area for the gripping elements 12 are distributed along the whole periphery of the pelt during the stretching of the pelt 2, which is effected by a relative displacement of the distension element/board 4 and the gripping elements 12, typically by effecting a displacement of the holding means 8 for the foot 24 of the pelt board placed on U-shaped bracket plate 100 in the direction of the guide rail 102.

As already mentioned, the stretching of the pelt can be further increased by activating a vibrator unit 60 during the above-described stretching of the pelt, which naturally places further demands regarding the distribution of the tractive forces in the area where the gripping elements 12 engage the lower end 18 (the tail end) of the pelt, which with the gripping elements 12 according to the invention said demands are fulfilled.

With the invention there is thus achieved an almost revolutionary development of the stretching and fastening procedure, which is expected to be introduced as standard within the production of pelts, and which will change the competitive conditions on the market to a considerable degree.

As already mentioned, the inventor has recognised that the gripping elements for the stretching machine for the execution of the method according to the invention can be of configurations other than that disclosed in the present description, but this does not change the inventive aspect, which consists of providing a method where a pelt during the stretching procedure is engaged by gripping elements practically speaking along the whole of the pelt's lower edge, by configuring the gripping elements with a cross-section which is relevant for a current distension element/pelt board.

**CLAIMS**

1. Method for non-destructive stretching and fastening of a pelt (2) on a distension element/pelt board (4), for which use is made of a stretching machine (6) of the  
5 kind comprising holding means (8) for engaging the lower end (24) of a relevant distension element/pelt board (4), and gripping elements (12) for fastening of the lower end (24) of a pelt (2) drawn loosely over said distension element/pelt board during the stretching of said pelt (2) on the distension element/pelt board (4), where the distension element/pelt board (4) is placed in holding means (8) and  
10 where the gripping elements (12) comprising inner parts (10) and outer parts (20) are brought into engagement with the pelt (2) by the introduction of the inner parts (10) between the surface (14) of the distension element/pelt board and the leather side (16) of the pelt, and the outer parts (20) opposite the inner parts (10) are displaced towards the fur side (22) of the pelt for the fastening of the pelt (2)  
15 between the inner parts (10) and the outer parts (20), where the stretching takes place by effecting a displacement between the gripping elements (12) and the holding means (8) for the lower end of a relevant distension element/pelt board (4), and where an effective fastening of the pelt (2) in the stretched position on the distension element/pelt board is established by the drawing of a fixing bag (26)  
20 over the outside of the fur side (22) of the pelt, which at least over a part of the lower end (18) (the tail end) of the pelt is brought into tight contact with the fur side (22) of the pelt, followed by a releasing of the gripping elements (12) from the pelt (2) and a releasing of the holding means (8) for the distension element (4),  
c h a r a c t e r i s e d in that the gripping elements (12) engage with and fasten  
25 the pelt (2) substantially along the whole periphery of the pelt.

2. Method according to claim 1, c h a r a c t e r i s e d in that during the relative displacement between the holding means (8) for the pelt board (4) and the gripping elements (12), a vibratory movement is imparted to said holding means  
30 (8) and/or the gripping elements (12), said movement oriented substantially in the longitudinal direction of the distension element/pelt board.

3. Stretching machine for use in the execution of the method disclosed in claim 1, and comprising holding means (8) for a distension element/pelt board (4), gripping

elements (12) which can be activated for engagement/fastening of the lower end (24) of a pelt (2) drawn loosely over distension element/pelt board (4), and means for effecting a relative displacement between the distension element/pelt board (4) and the gripping elements (12), and where the gripping elements (12) comprise at least two inner parts (10) which are led between the surface (14) of the distension element/pelt board (4) and the leather side (16) of the pelt from the lower end (24) of the board, and cooperating with the inner parts (10) at least two outer parts (20) with subtending sides which stand in connection with guiding and pressure means for displacement of the outer parts (2) between a closed position, where the outer parts are pressed into contact with the fur side (22) of the pelt for the fastening of the lower end of the pelt (2), and an open position where the pelt (2) is free, c h a r a c t e r i s e d in that the sides (25, 29) of the inner parts (10) and the outer parts (20) respectively, said sides (25, 29) facing towards the distension element/pelt board (4), are configured to match the shape of the distension element/pelt board (4), so that the gripping elements (12) engage with the lower end (18) of the pelt substantially along the whole of the outside periphery (14) of the distension element/pelt board (4).

4. Stretching machine (6) for execution of the method according to claim 2, c h a r a c t e r i s e d in that on the holding means (8) and/or the gripping elements (12) there is a vibrator unit (60) (which can be activated), the vibration amplitude of which is oriented substantially in the longitudinal direction of the distension element/pelt board.

5. Stretching machine according to claim 3 or 4, c h a r a c t e r i s e d in that the inner parts (10) comprise an upper counter-hold flange (27), the edge (28) of which on the side (30) facing away from the distension element/pelt board (4) comprises a track (32), and that the sides of the outer parts (20) facing towards the upper edge (28) comprise a pressure flange (33) which cooperates with the track (32) and has an edge (35) with a shape which corresponds to the shape of the track (32).

6. Stretching machine according to any of the claims 3-5, c h a r a c t e r i s e d in that the inner parts (10) of the gripping elements (12) consist of two open,

similarly-shaped but laterally reversed half parts (34, 36) which are displaceable towards each other, and which are housed on the respective brackets (38) which are disposed opposite each other via a pivot connection, where by actuators (40) said brackets (38) are displaceable towards and away from each other between a  
5 closed position where the subtending sides (42, 44) of the inner parts (10) are more less in contact with each other, and an open position where the inner parts (10) are lying at a distance from each other, and where the outer parts (20) are placed on pivotally mounted arms (46, 48) for the respective brackets (38), said arms (46, 48) being displaceable by actuators between a position where the flange  
10 edges (33) are pressed in against the tracks (32) in the upper edge (28) of the inner parts (10), and a position where said flange edges are lying at a distance from said tracks (32).

7. Stretching machine according to any of the claims 3-6, c h a r a c t e r i s e d in  
15 that the subtending sides (50) of the inner parts (10) extend in a concave manner.

8. Stretching machine according to any of the claims 3-7, c h a r a c t e r i s e d in  
that the counter-hold flanges (27) stand up from a plane part (52) which is oriented  
in a substantially transverse manner in relation to the extent of the counter-hold  
20 flanges.

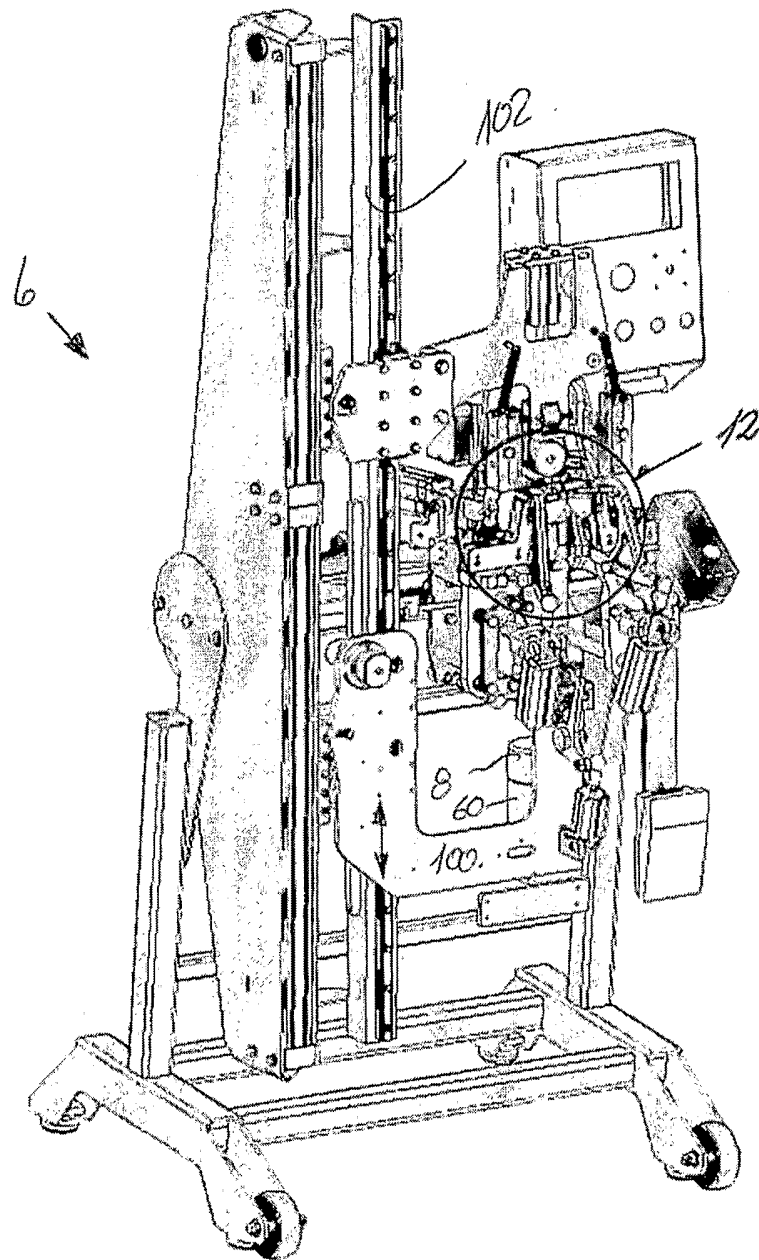

Fig. 1

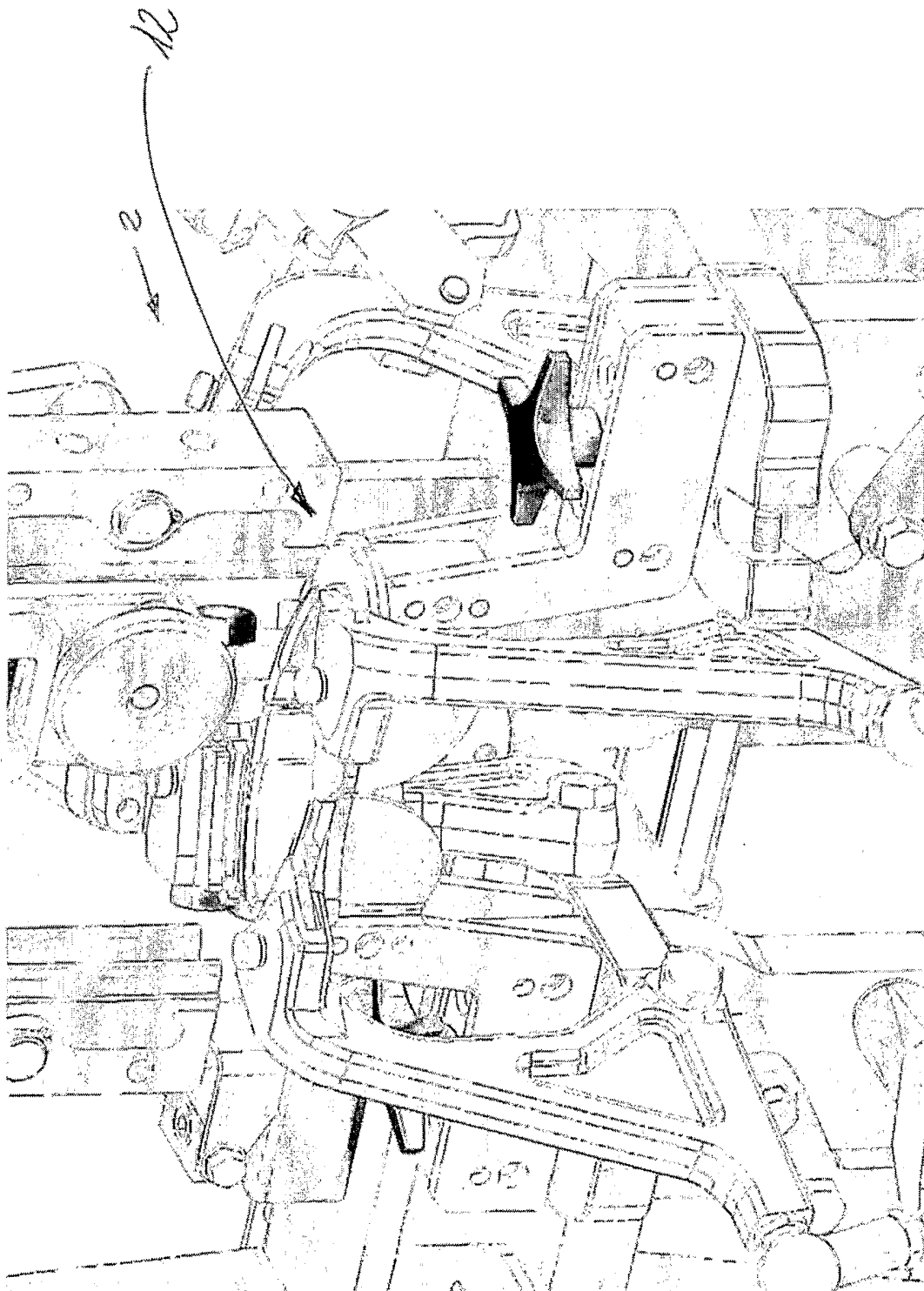

Fig. 2

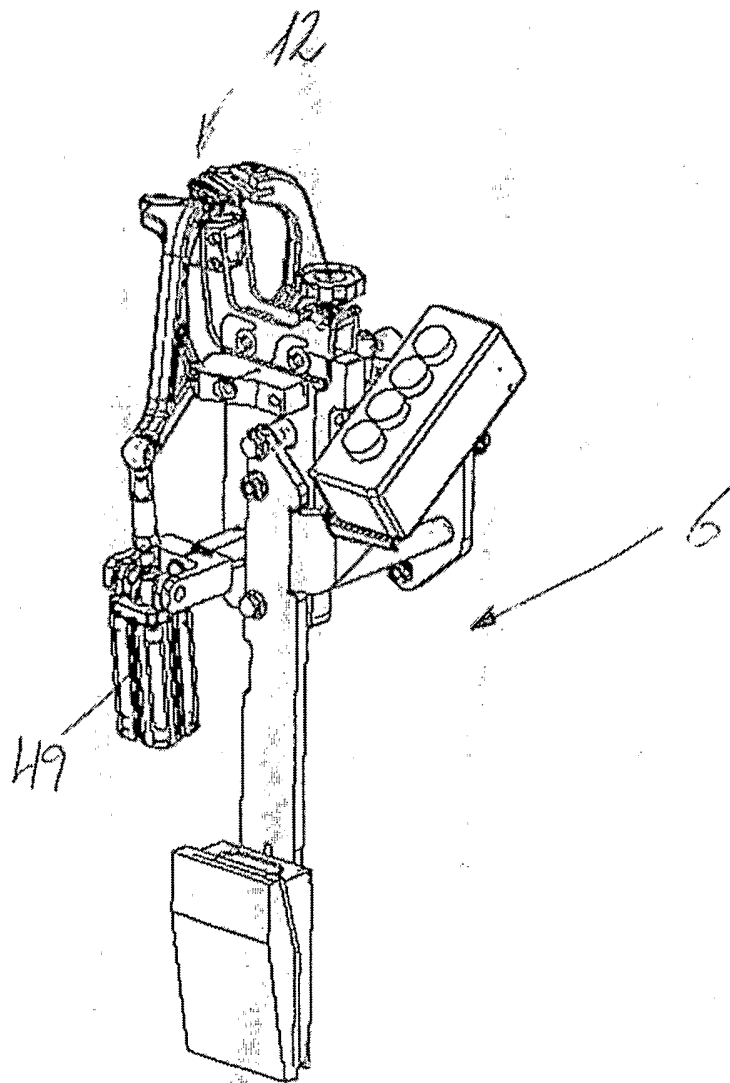

Fig. 3

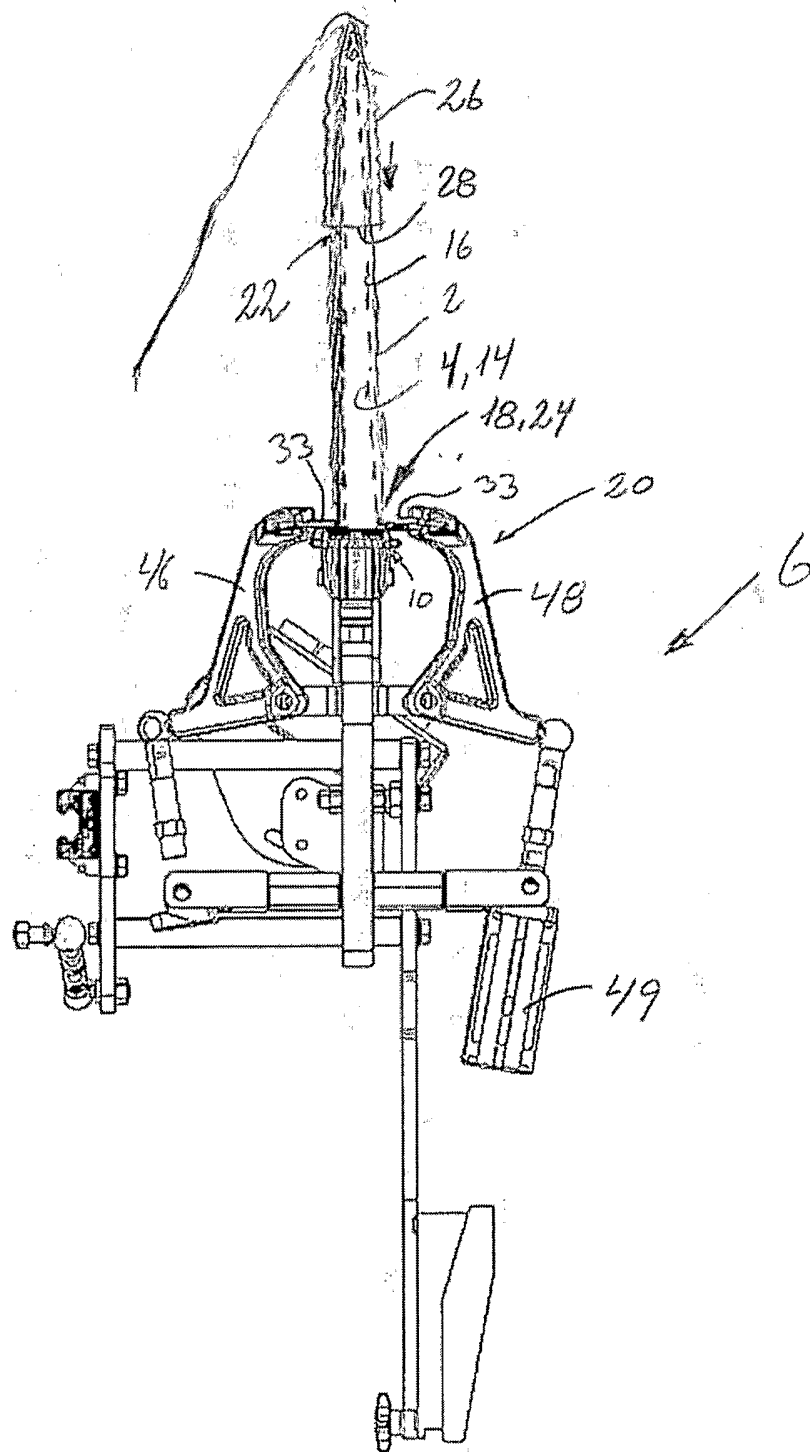

Fig. 4

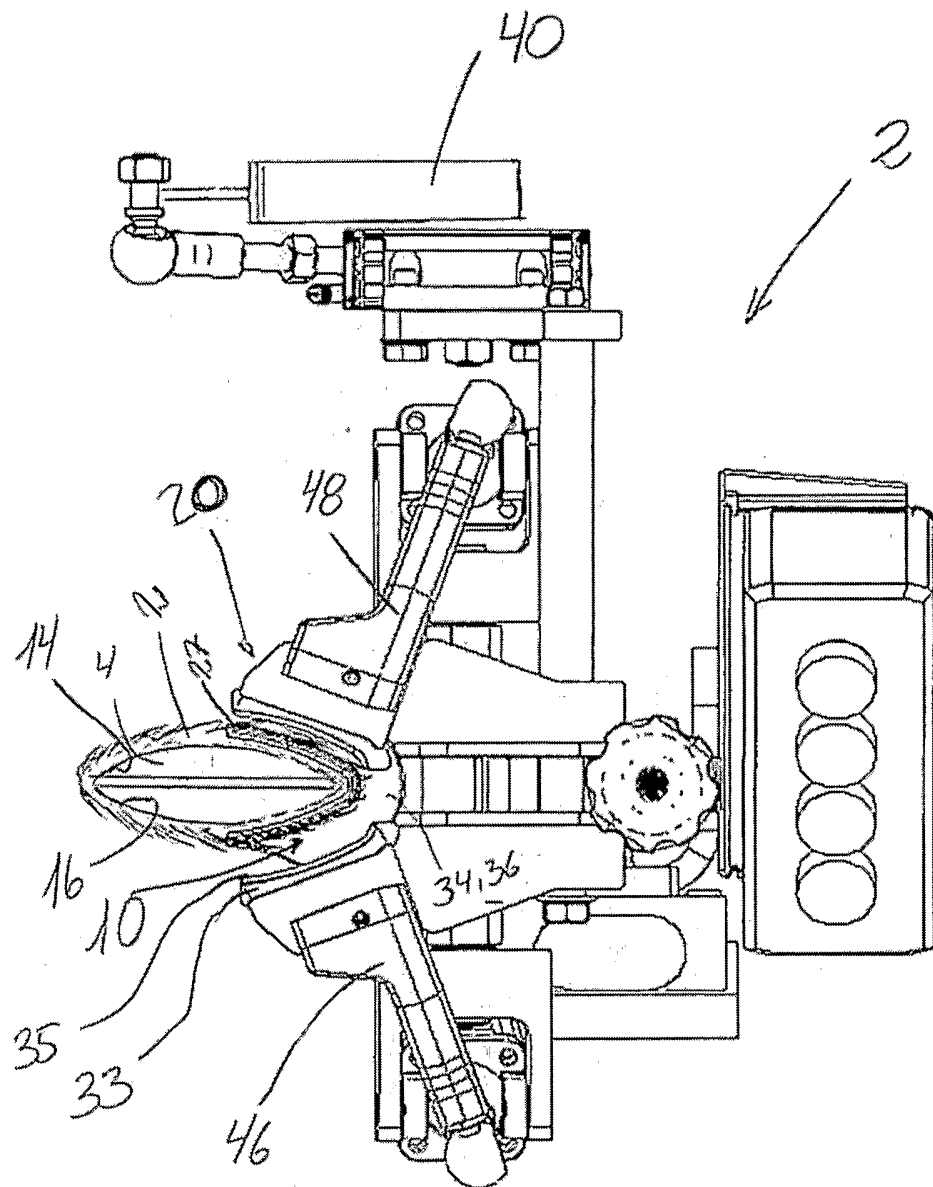

Fig. 5

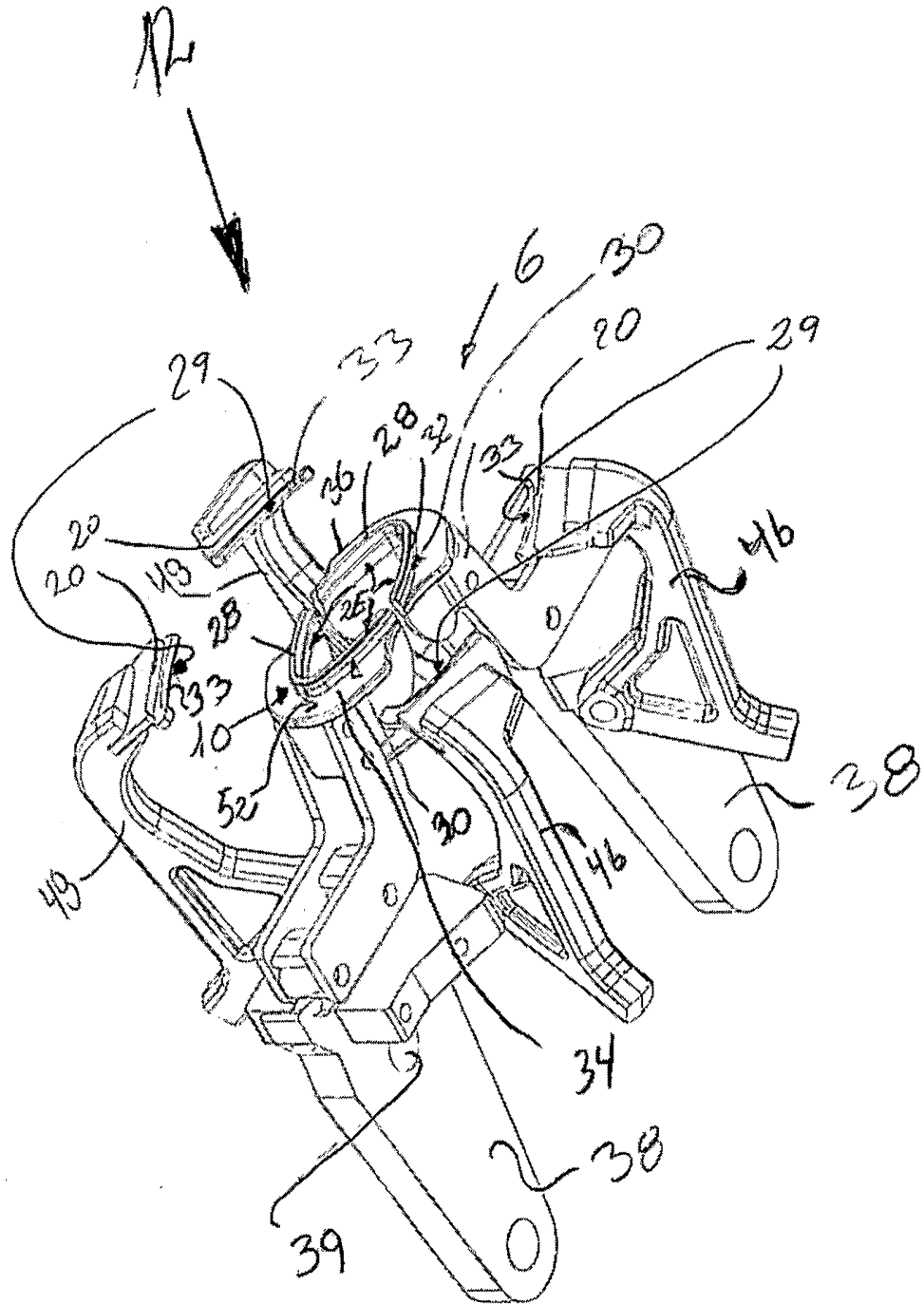

Fig. 6

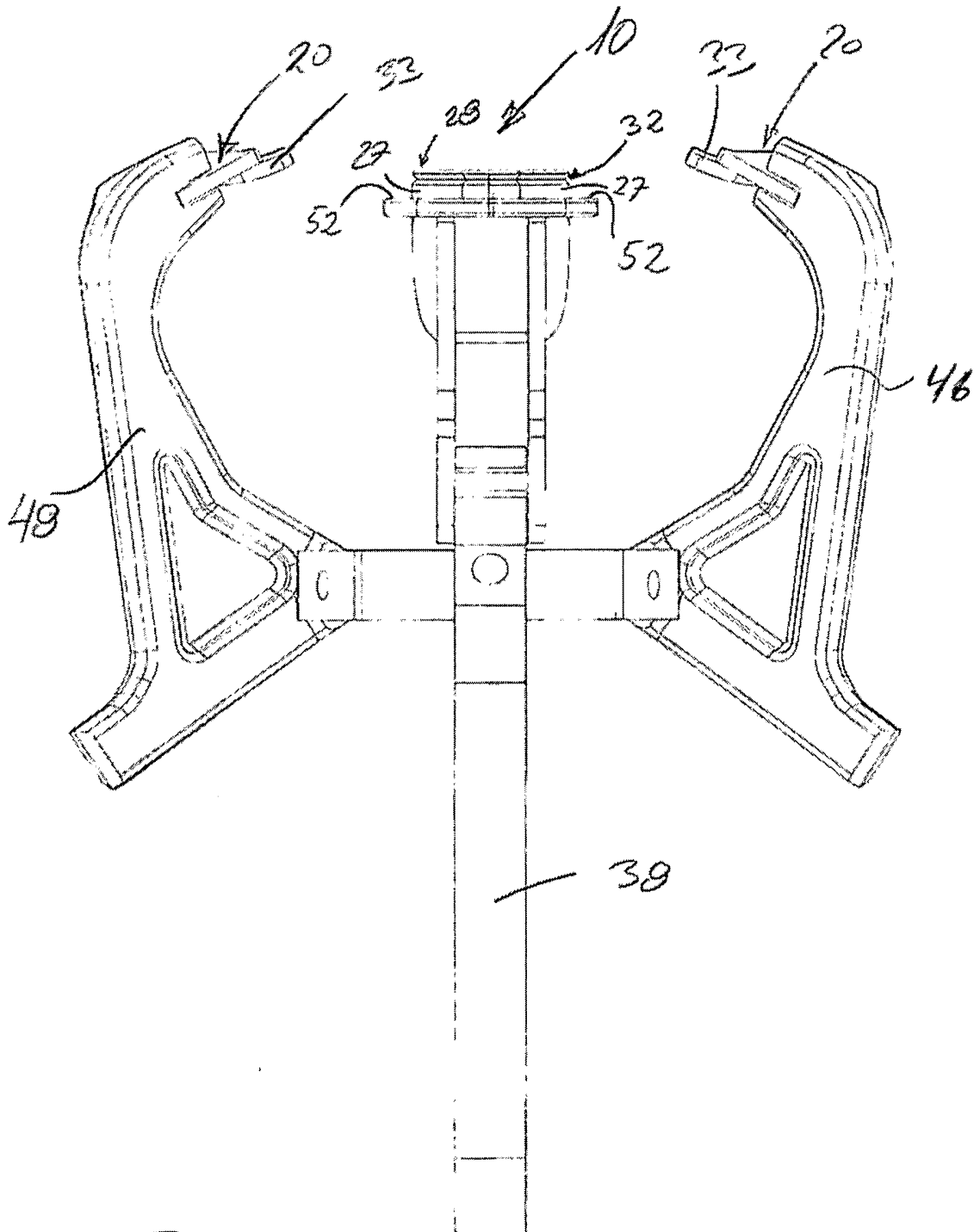

Fig. 7

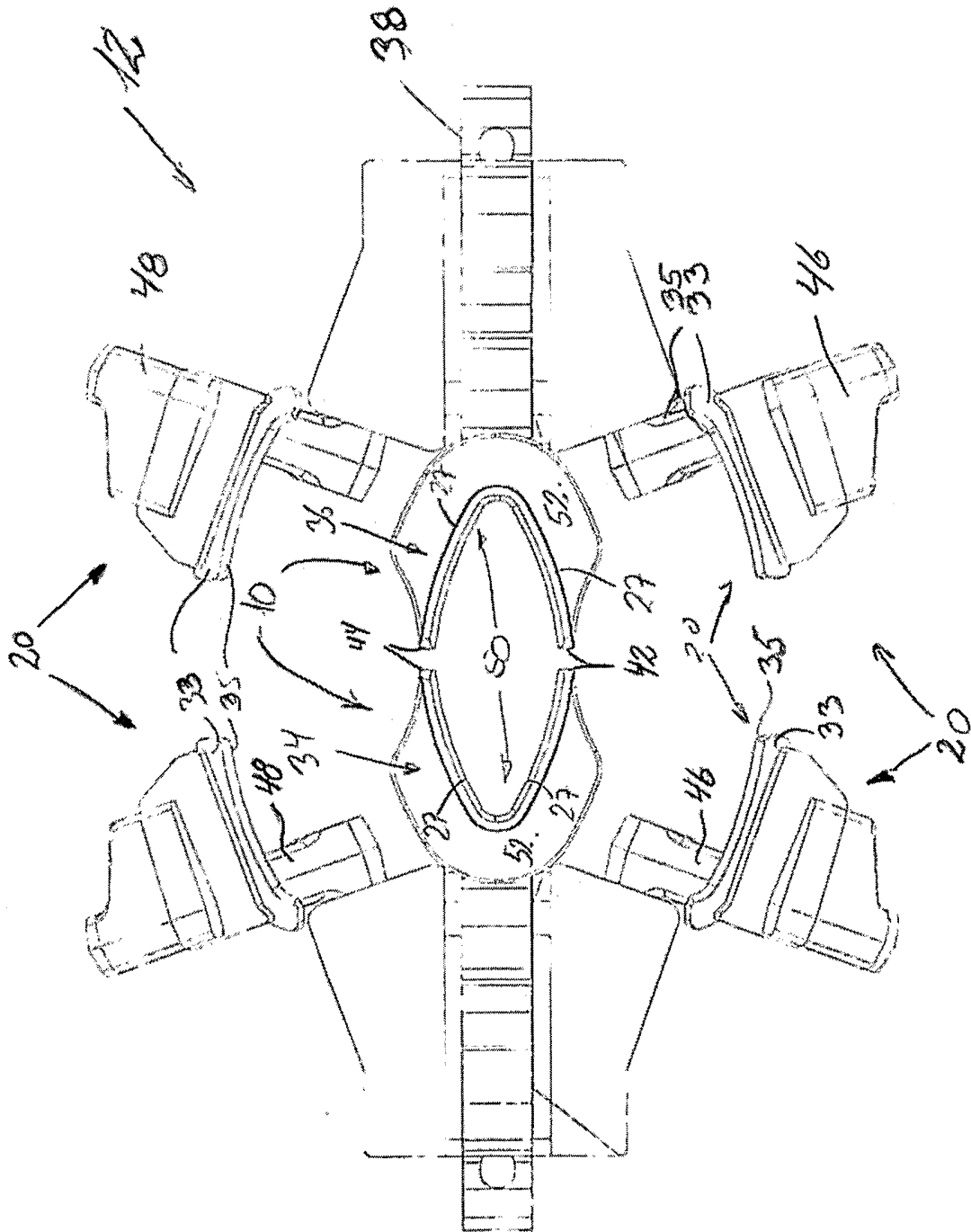
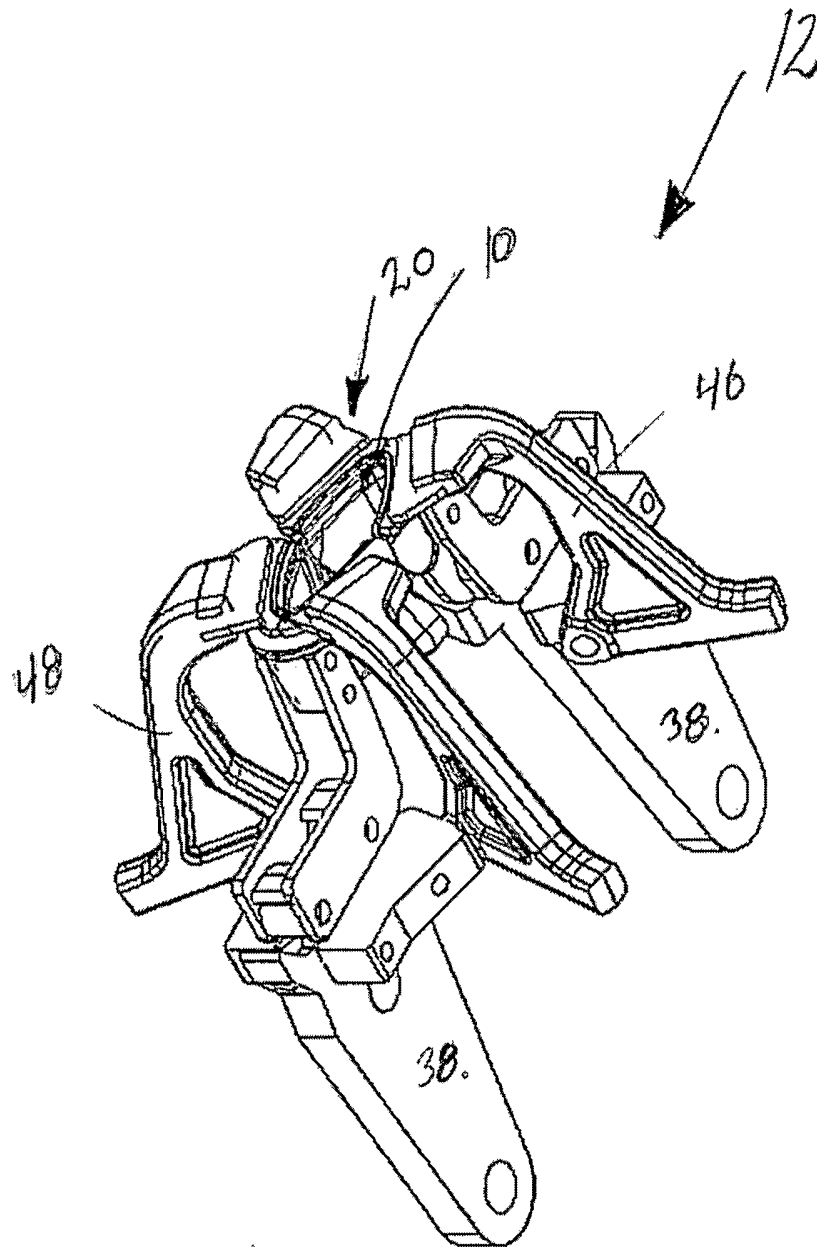

Fig. 8



*Fig. 9*

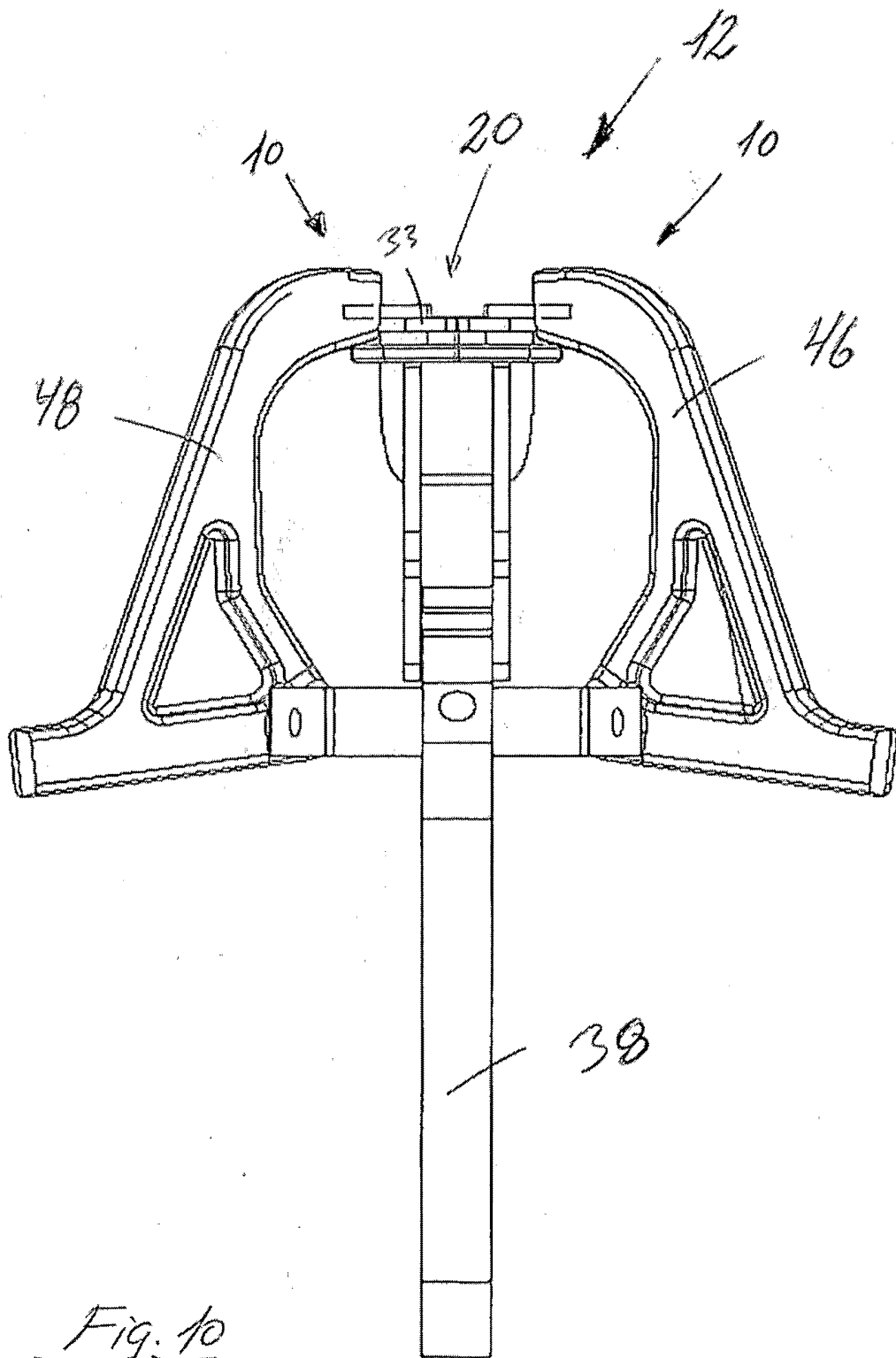

Fig. 10

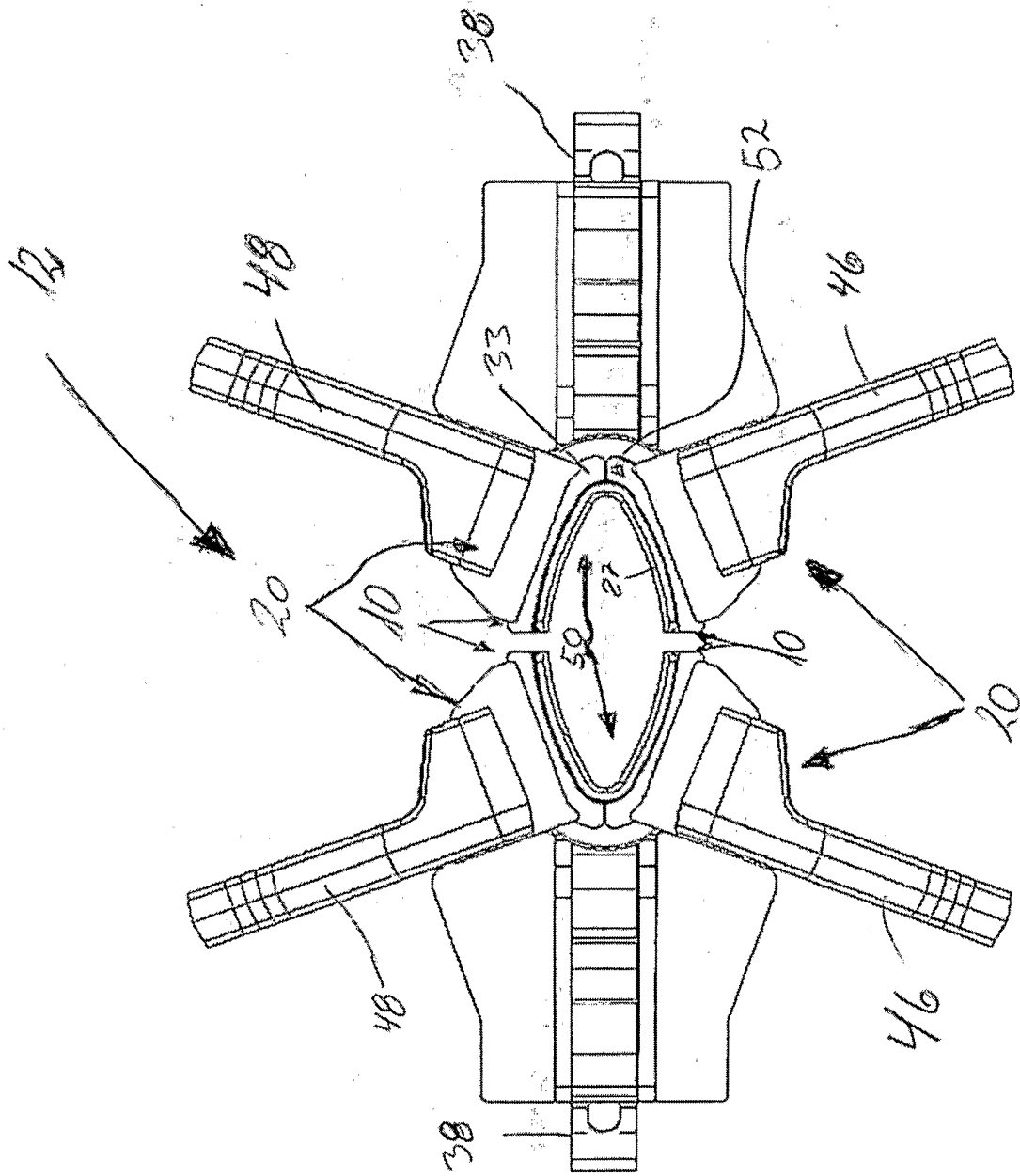

Fig. 11

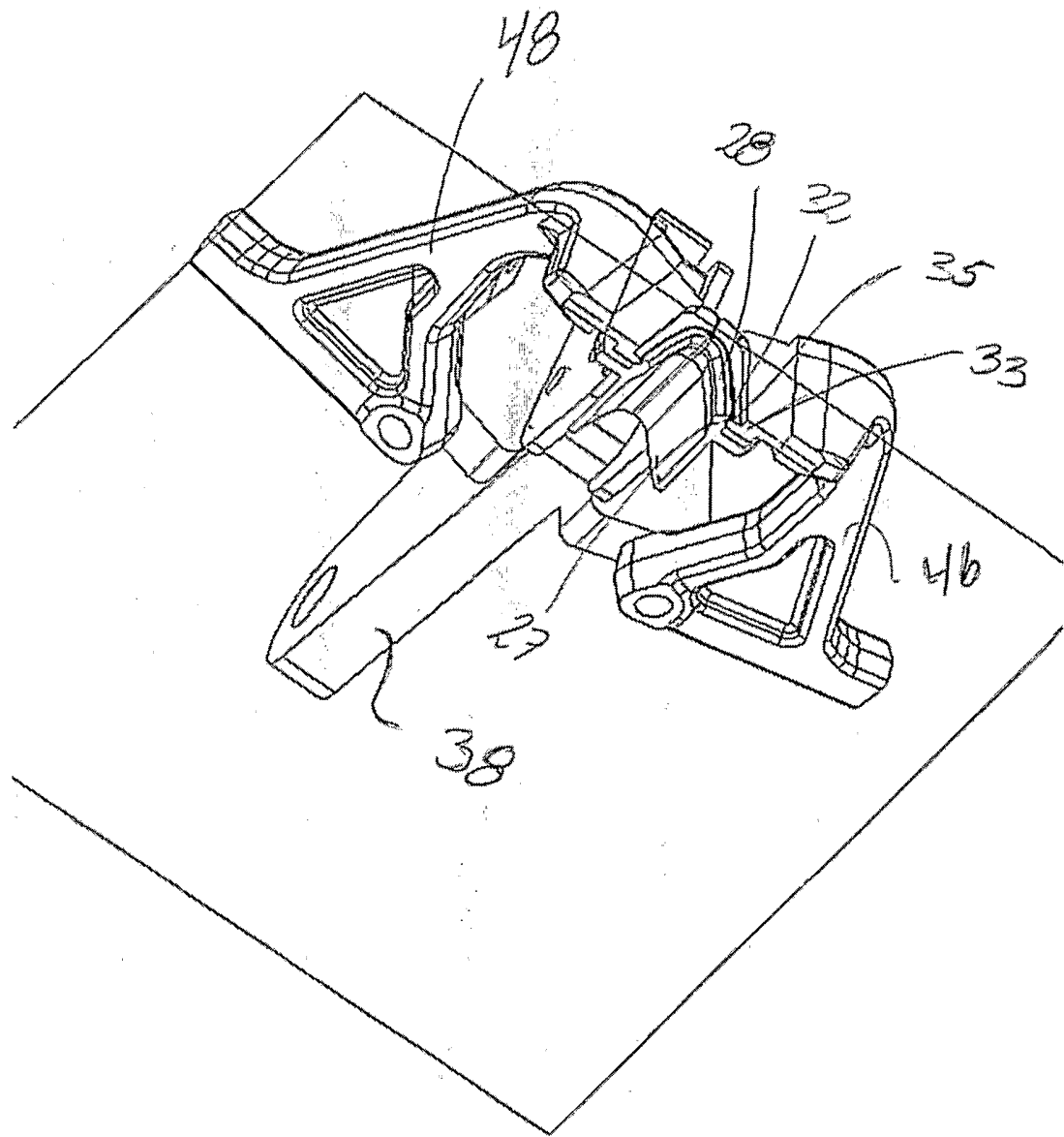

Fig. 12

# INTERNATIONAL SEARCH REPORT

International Application No  
PCT/DK2004/000636

<b>A. CLASSIFICATION OF SUBJECT MATTER</b> IPC 7 C14B15/06		
According to International Patent Classification (IPC) or to both national classification and IPC		
<b>B. FIELDS SEARCHED</b>		
Minimum documentation searched (classification system followed by classification symbols) IPC 7 C14B		
Documentation searched other than minimum documentation to the extent that such documents are included in the fields searched		
Electronic data base consulted during the international search (name of data base and, where practical, search terms used) EPO-Internal, WPI Data, PAJ		
<b>C. DOCUMENTS CONSIDERED TO BE RELEVANT</b>		
Category °	Citation of document, with indication, where appropriate, of the relevant passages	Relevant to claim No.
A	WO 02/44428 A (HEDEGAARD JENS) 6 June 2002 (2002-06-06) cited in the application the whole document	1,3
<input type="checkbox"/> Further documents are listed in the continuation of box C.		
<input checked="" type="checkbox"/> Patent family members are listed in annex.		
° Special categories of cited documents :		
*A* document defining the general state of the art which is not considered to be of particular relevance *E* earlier document but published on or after the international filing date *L* document which may throw doubts on priority claim(s) or which is cited to establish the publication date of another citation or other special reason (as specified) *O* document referring to an oral disclosure, use, exhibition or other means *P* document published prior to the international filing date but later than the priority date claimed		
*T* later document published after the international filing date or priority date and not in conflict with the application but cited to understand the principle or theory underlying the invention *X* document of particular relevance; the claimed invention cannot be considered novel or cannot be considered to involve an inventive step when the document is taken alone *Y* document of particular relevance; the claimed invention cannot be considered to involve an inventive step when the document is combined with one or more other such documents, such combination being obvious to a person skilled in the art. *&* document member of the same patent family		
Date of the actual completion of the international search  14 January 2005		Date of mailing of the international search report  25/01/2005
Name and mailing address of the ISA European Patent Office, P.B. 5818 Patentlaan 2 NL - 2280 HV Rijswijk Tel. (+31-70) 340-2040, Tx. 31 651 epo nl, Fax: (+31-70) 340-3016		Authorized officer  Helpiö, T.

# INTERNATIONAL SEARCH REPORT

Information on patent family members

International Application No

PCT/DK2004/000636

Patent document cited in search report		Publication date		Patent family member(s)	Publication date
WO 0244428	A	06-06-2002	DK	200001793 A	05-04-2002
			AU	2051602 A	11-06-2002
			CA	2430264 A1	06-06-2002
			WO	0244428 A1	06-06-2002
			EP	1346066 A1	24-09-2003
			US	2004060330 A1	01-04-2004

---