

**(12) STANDARD PATENT**  
**(19) AUSTRALIAN PATENT OFFICE**

(11) Application No. **AU 2015355337 B2**

(54) Title  
**Advance diagnosis of infusion device operating mode viability**

(51) International Patent Classification(s)  
**G06F 19/00** (2006.01) **A61M 5/172** (2006.01)

(21) Application No: **2015355337** (22) Date of Filing: **2015.11.25**

(87) WIPO No: **WO16/089701**

(30) Priority Data

(31) Number	(32) Date	(33) Country
<b>14/561,128</b>	<b>2014.12.04</b>	<b>US</b>

(43) Publication Date: **2016.06.09**

(44) Accepted Journal Date: **2018.10.11**

(71) Applicant(s)  
**Medtronic Minimed, Inc.**

(72) Inventor(s)  
**Monirabbasi, Salman;Lintereur, Louis J.;Yan, Jin**

(74) Agent / Attorney  
**FPA Patent Attorneys Pty Ltd, Level 43 101 Collins Street, Melbourne, VIC, 3000, AU**

(56) Related Art  
**US 20040122353 A1**  
**US 20140107607 A1**  
**US 20080300572 A1**



- (51) International Patent Classification:  
G06F 19/00 (2011.01) A61M 5/172 (2006.01)
- (21) International Application Number:  
PCT/US2015/062748
- (22) International Filing Date:  
25 November 2015 (25.11.2015)
- (25) Filing Language: English
- (26) Publication Language: English
- (30) Priority Data:  
14/561,128 4 December 2014 (04.12.2014) US
- (71) Applicant: MEDTRONIC MINIMED, INC. [US/US];  
18000 Devonshire Street, Northridge, California 91325-1219 (US).

- (72) Inventors: MONIRABBASI, Salman; 7100 Playa Vista Dr, #409, Playa Vista, California 90094 (US). LINTEREUR, Louis J.; 25512 Magnolia Lane, Stevenson Ranch, California 91381 (US). YAN, Jin; 10519 Eton Avenue, Chatsworth, California 91311 (US).
- (74) Agent: WALTERS, James R.; Ingrassia Fisher & Lorenz, PC, 7010 E. Cochise Rd., Scottsdale, Arizona 85253 (US).
- (81) Designated States (unless otherwise indicated, for every kind of national protection available): AE, AG, AL, AM, AO, AT, AU, AZ, BA, BB, BG, BH, BN, BR, BW, BY, BZ, CA, CH, CL, CN, CO, CR, CU, CZ, DE, DK, DM, DO, DZ, EC, EE, EG, ES, FI, GB, GD, GE, GH, GM, GT, HN, HR, HU, ID, IL, IN, IR, IS, JP, KE, KG, KN, KP, KR, KZ, LA, LC, LK, LR, LS, LU, LY, MA, MD, ME, MG, MK, MN, MW, MX, MY, MZ, NA, NG, NI, NO, NZ, OM, PA, PE, PG, PH, PL, PT, QA, RO, RS, RU, RW, SA, SC, SD, SE, SG, SK, SL, SM, ST, SV, SY, TH, TJ, TM, TN, TR, TT, TZ, UA, UG, US, UZ, VC, VN, ZA, ZM, ZW.
- (84) Designated States (unless otherwise indicated, for every kind of regional protection available): ARIPO (BW, GH,

[Continued on next page]

(54) Title: ADVANCE DIAGNOSIS OF INFUSION DEVICE OPERATING MODE VIABILITY

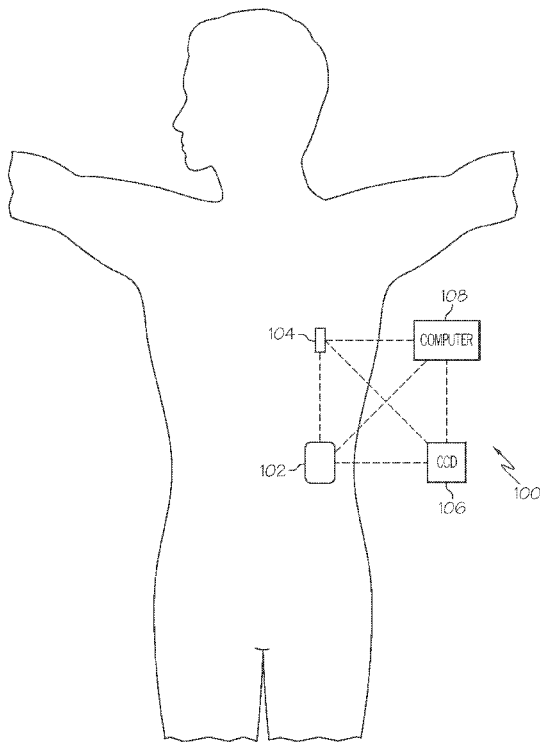

FIG. 1

(57) Abstract: Infusion systems, infusion devices, and related operating methods are provided. An exemplary method of operating an infusion device to deliver fluid to a user in accordance with an operating mode involves obtaining operational information pertaining to one or more prior instances of the operating mode, obtaining status information pertaining to the infusion device, and determining a diagnosis time based at least in part on the operational information. The diagnosis time is prior to a subsequent instance of the operating mode. At the diagnosis time, the method automatically determines the viability of the subsequent instance of the operating mode based at least in part on the status information and automatically generates a notification indicative of a recommended action for the user based at least in part on the viability.

WO 2016/089701 A1

GM, KE, LR, LS, MW, MZ, NA, RW, SD, SL, ST, SZ,  
TZ, UG, ZM, ZW), Eurasian (AM, AZ, BY, KG, KZ, RU,  
TJ, TM), European (AL, AT, BE, BG, CH, CY, CZ, DE,  
DK, EE, ES, FI, FR, GB, GR, HR, HU, IE, IS, IT, LT,  
LU, LV, MC, MK, MT, NL, NO, PL, PT, RO, RS, SE,

SI, SK, SM, TR), OAPI (BF, BJ, CF, CG, CI, CM, GA,  
GN, GQ, GW, KM, ML, MR, NE, SN, TD, TG).

**Published:**

— *with international search report (Art. 21(3))*

## ADVANCE DIAGNOSIS OF INFUSION DEVICE OPERATING MODE VIABILITY

### CROSS-REFERENCE TO RELATED APPLICATIONS

[0001] This PCT application claims the benefit of, and claims priority to: United States Patent Application Serial Number 14/561,128, filed December 4, 2014.

### TECHNICAL FIELD

[0002] Embodiments of the subject matter described herein relate generally to medical devices, and more particularly, embodiments of the subject matter relate to managing transitions into fluid infusion device operating modes.

### BACKGROUND

[0003] Infusion pump devices and systems are relatively well known in the medical arts, for use in delivering or dispensing an agent, such as insulin or another prescribed medication, to a patient. A typical infusion pump includes a pump drive system which typically includes a small motor and drive train components that convert rotational motor motion to a translational displacement of a plunger (or stopper) in a reservoir that delivers medication from the reservoir to the body of a user via a fluid path created between the reservoir and the body of a user. Use of infusion pump therapy has been increasing, especially for delivering insulin for diabetics.

[0004] Continuous insulin infusion provides greater control of a diabetic's condition, and hence, control schemes are being developed that allow insulin infusion pumps to monitor and regulate a user's blood glucose level in a substantially continuous and autonomous manner. For example, an insulin infusion pump may operate in a closed-loop operating mode overnight while a user is sleeping to regulate the user's glucose level to a target glucose level. In practice, multiple different operating modes for providing continuous insulin infusion may be supported by an infusion pump. However, care must be taken when transitioning between operating modes to avoid potentially compromising a user's condition and ensure compliance with applicable regulatory requirements.

[0005] Additionally, in some situations, one or more preconditions must be satisfied before entering to a particular operating mode is allowed. When preconditions are not satisfied, entry into the operating mode may be denied, which may frustrate a user who would like to operate the infusion pump in that particular operating mode at that particular

moment in time. Additionally, after entering a particular operating mode, various conditions may be encountered while operating the infusion pump in that operating mode that result in generation of alerts, which could be disruptive or distracting to the user. Thus, it is desirable to provide multiple different operating modes that facilitate greater and more customizable control over the user's physiological condition without degrading the user experience.

[0005A] Reference to any prior art in the specification is not an acknowledgment or suggestion that this prior art forms part of the common general knowledge in any jurisdiction or that this prior art could reasonably be expected to be combined with other pieces of prior art by a skilled person in the art.

#### BRIEF SUMMARY

[0006] Infusion devices, systems and related methods of operation in accordance with various operating modes are provided.

[0006A] In a first aspect, the present invention provides a method of operating an infusion device configured to deliver fluid to a user in accordance with a closed-loop operating mode to regulate a physiological condition of the user to a target value using one or more control parameters, the method comprising: obtaining operational information pertaining to one or more prior instances of the closed-loop operating mode; obtaining status information pertaining to the infusion device; determining an expected start time for a subsequent instance of the closed-loop operating mode based on the operational information; determining an expected duration for the subsequent instance of the closed-loop operating mode; determining a diagnosis time prior to the expected start time for the subsequent instance of the closed-loop operating mode; and at the diagnosis time prior to the expected start time: automatically determining viability of entering the subsequent instance of the closed-loop operating mode at the expected start time for the expected duration based at least in part on the status information at the diagnosis time by performing an algorithmic diagnostic check to determine availability of the closed-loop operating mode at the expected start time in the future for the subsequent instance of the closed-loop operating mode, wherein the algorithmic diagnostic check comprises determining whether the one or more control parameters can be calculated at the expected start time; and automatically generating a recommendation to the user of a corrective action if the subsequent instance of the closed-loop operating mode is determined as not being viable.

[0006B] Also disclosed is a method of operating an infusion device to deliver fluid to a user in accordance with a first operating mode involves obtaining operational information pertaining to one or more prior instances of the first operating mode, obtaining status information pertaining to the infusion device, and determining a diagnosis time based at least in part on the operational information. The diagnosis time is prior to a subsequent instance of the first operating mode. This would typically be during a period in which the infusion device is operating in another operating mode. At the diagnosis time, the method automatically determines the viability of the subsequent instance of the operating mode based at least in part on the status information at the diagnosis time. Optionally, the method then automatically generates a notification indicative of a recommended action for the user based at least in part on the viability.

[0006C] In a second aspect, the present invention provides an infusion device capable of operating in a given operating mode comprising: a user interface; a data storage element to maintain status information pertaining to the infusion device and operational information pertaining to one or more prior instances of the closed-loop operating mode; a motor operable to deliver fluid to a body of a user, the fluid influencing a physiological condition of the user; and a control system coupled to the motor, the data storage element, and the user interface, and configured to perform the method of the first aspect.

[0007] In one embodiment, an infusion device is provided. The infusion device includes a user interface, a data storage element to maintain status information pertaining to the infusion device, a motor operable to deliver fluid influencing a physiological condition to a body of a user, and a control system. The control system is coupled to the motor, the data storage element, and the user interface. The control system operates the motor in a first instance of an operating mode to deliver the fluid in accordance with the operating mode, stores operational information pertaining to the first instance of the operating mode in the data storage element, and determines a diagnosis time based at least in part on the operational information pertaining to the first instance of the operating mode. At the diagnosis time, the control system automatically determines the viability of a subsequent instance of the operating mode based at least in part on the status information and automatically provides a notification indicative of a recommended action via the user interface based at least in part on the viability.

[0007A] In a third aspect, the present invention provides an infusion system comprising: a user interface; a sensing arrangement to obtain measurements of a physiological condition in a body of a user; and an infusion device coupled to the user interface and the sensing arrangement, the infusion device being operable to: deliver fluid influencing the physiological condition of the user to the body of the user based at least in part on the measurements in accordance with a closed-loop operating mode to regulate the physiological condition of the user to a target value using one or more control parameters; maintain status information pertaining to operation of the infusion device and operational information pertaining to one or more previous instances of the closed-loop operating mode; determine an expected start time for a subsequent instance of the closed-loop operating mode based on the operational information; determine an expected duration for the subsequent instance of the closed-loop operating mode; determine a diagnosis time in advance of the expected start time for the subsequent instance of the closed-loop operating mode based at least in part on the operational information; and at the diagnosis time prior to the expected start time: automatically determine viability of the subsequent instance of the closed-loop operating mode based at least in part on the status information by performing an algorithmic diagnostic check to determine availability of the closed-loop operating mode at the expected start time in the future for the subsequent instance of the closed-loop operating mode, wherein the algorithmic diagnostic check comprises determining whether the one or more control parameters can be calculated at the expected start time; and automatically provide, via the user interface, a recommendation to the user of a corrective action if the subsequent instance of the closed-loop operating mode is determined as not being viable.

[0008] An embodiment of an infusion system is also provided. The infusion system includes a user interface, a sensing arrangement to obtain measurements of a physiological condition in a body of a user, and an infusion device coupled to the user interface and the sensing arrangement. The infusion device delivers fluid influencing the physiological condition to the body of the user based at least in part on the measurements in accordance with an operating mode. The infusion device maintains status information pertaining to operation of the infusion device and operational information pertaining to one or more previous instances of the operating mode, and determines a diagnosis time in advance of an expected start time for a subsequent instance of the operating mode based at least in part on the operational information. At the diagnosis time, the infusion device

automatically determines the viability of the subsequent instance of the operating mode based at least in part on the status information and automatically provides a notification indicative of a recommended action via the user interface based at least in part on the viability.

**[0008A]** In a fourth aspect, the present invention provides an infusion device for a medicinal fluid, the device including: a user interface; a motor operable to deliver the fluid in response to commands; a sensor configured to sense a physiological condition influenced by the medicinal fluid; a pump control module coupled to the user interface, the motor, and the sensor, and including: a command generator comprising; a first algorithm which when executed causes the command generator to issue commands to the motor to deliver the fluid according to a predetermined schedule; and a second algorithm which when executed causes the command generator to issue commands to the motor to deliver fluid to implement a closed-loop control to bring the measured physiological condition to a target value, said second algorithm having gain coefficients; the command generator further being switchable to execute either the first or the second algorithm; a diagnostic unit connected to the command generator; and configured to receive an expected start time for a future switching of the command generator from the first algorithm to the second algorithm and starting a buffer time period before the expected start time checking the viability of operation of the closed-loop control of the command generator for an expected duration after the future switching time by performing an algorithmic diagnostic check to determine that the second algorithm gain coefficients can be calculated at the expected start time; the diagnostic unit also being configured to provide, to the user interface, a recommendation of a corrective action if the closed-loop control is determined as not being viable.

**[0009]** The disclosure also provides an infusion device for a medicinal fluid, the device including: a user interface; a motor operable to deliver the fluid in response to commands; a sensor configured to sense a physiological condition influenced by the medicinal fluid; a pump control module coupled to the user interface, the motor, and the sensor, and including: a command generator comprising; a first algorithm which when executed causes the command generator to issue commands to the motor to deliver the fluid according to a predetermined schedule; and a second algorithm which when executed causes the command generator to issue commands to the motor to deliver fluid to

implement a closed-loop control to bring the measured physiological condition to a target value, said second algorithm having gain coefficients, (preferably PID); the command generator further being switchable to execute either the first or the second algorithm; a diagnostic unit connected to the command generator; and configured to receive an expected time for a future switching of the command generator from the first algorithm to the second algorithm and starting a buffer time period before the expected time checking the viability of operation of the command generator after the future switching time by checking that the second algorithm gain coefficients can be calculated before the said future switching time; the diagnostic unit also being configured to report said viability to the user interface.

[0010] The infusion device may further include a memory connected to record the start times of the day of each period during which the second algorithm is executed and

said expected future time may be set to an average of said start times. The infusion device may further include a memory connected to record the duration times of each period during which the second algorithm is executed and said diagnostic unit may report a lack of viability, if battery status, medicinal fluid reserve, or currency of sensor calibration would not last the average of said duration times starting at said expected future switching time. The medicinal fluid may be insulin and the physiological condition may be blood glucose concentration.

**[0011]** The operating modes may be selected from a list comprising open-loop mode, closed-loop mode, LGS mode in which a basal rate of delivery of the medicinal fluid is provided while a physiological analyte level that is controlled by the medicinal fluid is above a threshold and suspended while it is not, and PLGM mode in which a basal rate of delivery of the medicinal fluid is provided while a predicted level of the physiological analyte that is controlled by the medicinal fluid is above a threshold and suspended while it is not. The medicinal fluid may be insulin.

**[0012]** This summary is provided to introduce a selection of concepts in a simplified form that are further described below in the detailed description. This summary is not intended to identify key features or essential features of the claimed subject matter, nor is it intended to be used as an aid in determining the scope of the claimed subject matter.

#### BRIEF DESCRIPTION OF THE DRAWINGS

**[0013]** A more complete understanding of the subject matter may be derived by referring to the detailed description and claims when considered in conjunction with the following figures, wherein like reference numbers refer to similar elements throughout the figures, which may be illustrated for simplicity and clarity and are not necessarily drawn to scale.

**[0014]** FIG. 1 depicts an exemplary embodiment of an infusion system;

**[0015]** FIG. 2 depicts a plan view of an exemplary embodiment of a fluid infusion device suitable for use in the infusion system of FIG. 1;

**[0016]** FIG. 3 is an exploded perspective view of the fluid infusion device of FIG. 2;

**[0017]** FIG. 4 is a cross-sectional view of the fluid infusion device of FIGS. 2-3 as viewed along line 4-4 in FIG. 3 when assembled with a reservoir inserted in the infusion device;

**[0018]** FIG. 5 is a block diagram of an exemplary control system suitable for use in a fluid infusion device, such as the fluid infusion device of FIG. 1 or FIG. 2;

[0019] FIG. 6 is a block diagram of an exemplary pump control system suitable for use in the control system of FIG. 5;

[0020] FIG. 7 is a block diagram of a closed-loop control system that may be implemented or otherwise supported by the pump control system in the fluid infusion device of FIG. 5 in one or more exemplary embodiments;

[0021] FIG. 8 is a flow diagram of an exemplary transition diagnosis process suitable for use with the control system of FIG. 5;

#### DETAILED DESCRIPTION

[0022] The following detailed description is merely illustrative in nature and is not intended to limit the embodiments of the subject matter or the application and uses of such embodiments. As used herein, the word “exemplary” means “serving as an example, instance, or illustration.” Any implementation described herein as exemplary is not necessarily to be construed as preferred or advantageous over other implementations. Furthermore, there is no intention to be bound by any expressed or implied theory presented in the preceding technical field, background, brief summary or the following detailed description.

[0023] While the subject matter described herein can be implemented in any electronic device that includes a motor, exemplary embodiments described below are implemented in the form of medical devices, such as portable electronic medical devices. Although many different applications are possible, the following description focuses on a fluid infusion device (or infusion pump) as part of an infusion system deployment. For the sake of brevity, conventional techniques related to infusion system operation, insulin pump and/or infusion set operation, and other functional aspects of the systems (and the individual operating components of the systems) may not be described in detail here. Examples of infusion pumps may be of the type described in, but not limited to, United States Patent numbers: 4,562,751; 4,685,903; 5,080,653; 5,505,709; 5,097,122; 6,485,465; 6,554,798; 6,558,320; 6,558,351; 6,641,533; 6,659,980; 6,752,787; 6,817,990; 6,932,584; and 7,621,893; each of which are herein incorporated by reference.

[0024] Described herein is a fluid infusion devices including a motor that is operable to linearly displace a plunger (or stopper) of a reservoir provided within the fluid infusion device to deliver a dosage of fluid, such as insulin, to the body of a user. However, as the invention relates to the operation of the infusion device and the structure necessary for that operation detail of any mechanical structures for conveying or propelling the fluid is given

as an example only. Dosage commands that govern operation of the motor, i.e. the device responsible for directly or indirectly imparting motion to the fluid, may be generated in an automated manner in accordance with the delivery control scheme associated with a particular operating mode. The fluid infusion device may be operated in any one of a number of operating modes and be able to switch between the modes. Examples of operating modes are closed-loop, predictive, and open-loop. The device typically contains algorithms which when executed implement respective ones of the operating modes. In that case switching modes involves switching from one algorithm to another. In a closed-loop operating mode, for example, the dosage commands are generated based on a difference between a current (or most recent) measurement of a physiological condition in the body of the user (e.g., an interstitial fluid glucose level in the case of diabetes management by infusion of insulin) and a target (or reference) value for that physiological condition. In a predictive operating mode, the dosage commands may be influenced by a predicted value (or anticipated measurement) for that physiological condition in the body of the user at some point in the future. Conversely, in an open-loop operating mode, the dosage commands may be configured to implement a predetermined delivery rate. Such rate may be substantially independent of the current or predicted measurements of the physiological condition of the user.

**[0025]** As described in greater detail below primarily in the context of FIG. 8, in one or more exemplary embodiments, one or more diagnostic checks are performed prior to when an operating mode is entered to determine whether or not the operating mode will be viable at the expected time of entry. In this regard, various operating modes may require a particular amount of historical delivery data, measurement data, calibration data, or the like in order to calculate control parameters for implementing the operating mode. Accordingly, the diagnostic checks verify or otherwise confirm the required information is available for calculating the control parameter for implementing a subsequent instance of the operating mode. Additionally, the diagnostic checks may verify or otherwise confirm the operational status of various physical components of the infusion device to ensure those components are unlikely to be the root cause of any user alerts generated when the operating mode is implemented. For example, physical diagnostic checks may verify the remaining amount of battery life, the remaining amount of fluid in the reservoir, the amount of life remaining on the sensor(s), and the like are sufficient to last throughout the anticipated duration of the next instance of the operating mode.

[0026] The diagnostic checks may be performed at or starting at a particular time prior to the beginning of the new operating mode. This time is referred to below as the diagnosis time. In exemplary embodiments, operational information (e.g., start time, duration, and the like) derived from one or more prior instances of the operating mode is utilized to determine the diagnosis time (i.e., the time at which the diagnostic check(s) should be performed prior to an anticipated subsequent instance of the operating mode). At that diagnosis time in advance of the expected start time, various physical and algorithmic diagnostic checks are automatically performed to determine the viability of reinitiating or reentering the operating mode at that expected start time. The diagnostic checks determine the viability based at least in part on status information pertaining to the current and/or previous operation of the infusion device. This status information may include clinical status information or data for the patient (e.g., historical delivery data, reference measurement data, sensor measurement data, sensor calibration data, and the like) along with physical status information for the infusion device or other components of the infusion system (e.g., current battery level for the infusion device and/or sensor(s), current reservoir fluid level, and the like). When it is determined that a subsequent instance of the operating mode is not likely to be viable at the expected start time based on the currently available status information, an alert or user notification is automatically generated and provided to the user. The user notification indicates one or more recommended remedial actions that may be undertaken by the user to improve the future viability of the operating mode. In this manner, the user may engage in remedial actions in advance of the expected start time to increase the likelihood if not ensure that the operating mode will be viable by the time the user would like to reenter the operating mode. Additionally, remedial actions may also increase the likelihood if not ensure that the operating mode can be implemented for an anticipated duration without generating additional alerts that could otherwise require action by the user while in the operating mode. Thus, the overall user experience is improved by increasing the likelihood that the operating mode will be available when the user would like to enter the operating mode, while also decreasing the likelihood of the user being disturbed by additional alerts once the infusion device is implementing that operating mode.

[0027] Turning now to FIG. 1, one exemplary embodiment of an infusion system 100 includes, without limitation, a fluid infusion device (or infusion pump) 102, a sensing arrangement 104, a command control device (CCD) 106, and a computer 108. The components of an infusion system 100 may be realized using different platforms, designs,

and configurations, and the embodiment shown in FIG. 1 is not exhaustive or limiting. In practice, the infusion device 102 and the sensing arrangement 104 are secured at desired locations on the body of a user (or patient), as illustrated in FIG. 1. In this regard, the locations at which the infusion device 102 and the sensing arrangement 104 are secured to the body of the user in FIG. 1 are provided only as a representative, non-limiting, example. The elements of the infusion system 100 may be similar to those described in United States Patent No. 8,674,288, the subject matter of which is hereby incorporated by reference in its entirety.

**[0028]** In the illustrated embodiment of FIG. 1, the infusion device 102 is designed as a portable medical device suitable for infusing a fluid, a liquid, a gel, or other agent into the body of a user. In exemplary embodiments, the infused fluid is insulin, although many other fluids may be administered through infusion such as, but not limited to, HIV drugs, drugs to treat pulmonary hypertension, iron chelation drugs, pain medications, anti-cancer treatments, medications, vitamins, hormones, or the like. In some embodiments, the fluid may include a nutritional supplement, a dye, a tracing medium, a saline medium, a hydration medium, or the like.

**[0029]** The sensing arrangement 104 generally represents the components of the infusion system 100 configured to sense, detect, measure or otherwise quantify a condition of the user, and may include a sensor, a monitor, or the like, for providing data indicative of the condition that is sensed, detected, measured or otherwise monitored by the sensing arrangement. In this regard, the sensing arrangement 104 may include electronics and enzymes reactive to a biological condition, such as a blood glucose level, or the like, of the user, and provide data indicative of the blood glucose level to the infusion device 102, the CCD 106 and/or the computer 108. For example, the infusion device 102, the CCD 106 and/or the computer 108 may include a display for presenting information or data to the user based on the sensor data received from the sensing arrangement 104, such as, for example, a current glucose level of the user, a graph or chart of the user's glucose level versus time, device status indicators, alert messages, or the like. In other embodiments, the infusion device 102, the CCD 106 and/or the computer 108 may include electronics and software that are configured to analyze sensor data and operate the infusion device 102 to deliver fluid to the body of the user based on the sensor data and/or preprogrammed delivery routines. Thus, in exemplary embodiments, one or more of the infusion device 102, the sensing arrangement 104, the CCD 106, and/or the computer 108 includes a transmitter, a receiver, and/or other transceiver electronics that allow for communication

with other components of the infusion system 100, so that the sensing arrangement 104 may transmit sensor data or monitor data to one or more of the infusion device 102, the CCD 106 and/or the computer 108.

**[0030]** Still referring to FIG. 1, in various embodiments, the sensing arrangement 104 may be secured to the body of the user or embedded in the body of the user at a location that is remote from the location at which the infusion device 102 is secured to the body of the user. In various other embodiments, the sensing arrangement 104 may be incorporated within the infusion device 102. In other embodiments, the sensing arrangement 104 may be separate and apart from the infusion device 102, and may be, for example, part of the CCD 106. In such embodiments, the sensing arrangement 104 may be configured to receive a biological sample, analyte, or the like, to measure a condition of the user.

**[0031]** As described above, in some embodiments, the CCD 106 and/or the computer 108 may include electronics and other components configured to perform processing, delivery routine storage, and to control the infusion device 102 in a manner that is influenced by sensor data measured by and/or received from the sensing arrangement 104. By including control functions in the CCD 106 and/or the computer 108, the infusion device 102 may be made with more simplified electronics. However, in other embodiments, the infusion device 102 may include all control functions, and may operate without the CCD 106 and/or the computer 108. In various embodiments, the CCD 106 may be a portable electronic device. In addition, in various embodiments, the infusion device 102 and/or the sensing arrangement 104 may be configured to transmit data to the CCD 106 and/or the computer 108 for display or processing of the data by the CCD 106 and/or the computer 108.

**[0032]** In some embodiments, the CCD 106 and/or the computer 108 may provide information to the user that facilitates the user's subsequent use of the infusion device 102. For example, the CCD 106 may provide information to the user to allow the user to determine the rate or dose of medication to be administered into the user's body. In other embodiments, the CCD 106 may provide information to the infusion device 102 to autonomously control the rate or dose of medication administered into the body of the user. In some embodiments, the sensing arrangement 104 may be integrated into the CCD 106. Such embodiments may allow the user to monitor a condition by providing, for example, a sample of his or her blood to the sensing arrangement 104 to assess his or her condition. In some embodiments, the sensing arrangement 104 and the CCD 106 may be used for determining glucose levels in the blood and/or body fluids of the user without the

use of, or necessity of, a wire or cable connection between the infusion device 102 and the sensing arrangement 104 and/or the CCD 106.

**[0033]** In some embodiments, the sensing arrangement 104 and/or the infusion device 102 are cooperatively configured to utilize a closed-loop system for delivering fluid to the user. Examples of sensing devices and/or infusion pumps utilizing closed-loop systems may be found at, but are not limited to, the following United States patent numbers: 6,088,608, 6,119,028, 6,589,229, 6,740,072, 6,827,702, 7,323,142, and 7,402, 153, all of which are incorporated herein by reference in their entirety. In such embodiments, the sensing arrangement 104 is configured to sense or measure a condition of the user, such as, blood glucose level or the like. The infusion device 102 is configured to deliver fluid in response to the condition sensed by the sensing arrangement 104. In turn, the sensing arrangement 104 continues to sense or otherwise quantify a current condition of the user, thereby allowing the infusion device 102 to deliver fluid continuously in response to the condition currently (or most recently) sensed by the sensing arrangement 104 indefinitely. In some embodiments, the sensing arrangement 104 and/or the infusion device 102 may be configured to utilize the closed-loop system only for a portion of the day, for example only when the user is asleep or awake.

**[0034]** FIGS. 2-4 depict one exemplary embodiment of a fluid infusion device 200 (or alternatively, infusion pump) suitable for use in an infusion system, such as, for example, as infusion device 102 in the infusion system 100 of FIG. 1. The fluid infusion device 200 is a portable medical device designed to be carried or worn by a patient (or user), and the fluid infusion device 200 may leverage any number of conventional features, components, elements, and characteristics of existing fluid infusion devices, such as, for example, some of the features, components, elements, and/or characteristics described in United States Patent numbers 6,485,465 and 7,621,893. It should be appreciated that FIGS. 2-4 depict some aspects of the infusion device 200 in a simplified manner; in practice, the infusion device 200 could include additional elements, features, or components that are not shown or described in detail herein.

**[0035]** As best illustrated in FIGS. 2-3, the illustrated embodiment of the fluid infusion device 200 includes a housing 202 adapted to receive a fluid-containing reservoir 205. An opening 220 in the housing 202 accommodates a fitting 223 (or cap) for the reservoir 205, with the fitting 223 being configured to mate or otherwise interface with tubing 221 of an infusion set 225 that provides a fluid path to/from the body of the user. In this manner, fluid communication from the interior of the reservoir 205 to the user is

established via the tubing 221. The illustrated fluid infusion device 200 includes a human-machine interface (HMI) 230 (or user interface) that includes elements 232, 234 that can be manipulated by the user to administer a bolus of fluid (e.g., insulin), to change therapy settings, to change user preferences, to select display features, and the like. The infusion device also includes a display element 226, such as a liquid crystal display (LCD) or another suitable display element, that can be used to present various types of information or data to the user, such as, without limitation: the current glucose level of the patient; the time; a graph or chart of the patient's glucose level versus time; device status indicators; etc.

**[0036]** The housing 202 is formed from a substantially rigid material having a hollow interior 214 adapted to allow an electronics assembly 204, a sliding member (or slide) 206, a drive system 208, a sensor assembly 210, and a drive system capping member 212 to be disposed therein in addition to the reservoir 205, with the contents of the housing 202 being enclosed by a housing capping member 216. The opening 220, the slide 206, and the drive system 208 are coaxially aligned in an axial direction (indicated by arrow 218), whereby the drive system 208 facilitates linear displacement of the slide 206 in the axial direction 218 to dispense fluid from the reservoir 205 (after the reservoir 205 has been inserted into opening 220), with the sensor assembly 210 being configured to measure axial forces (e.g., forces aligned with the axial direction 218) exerted on the sensor assembly 210 responsive to operating the drive system 208 to displace the slide 206. In various embodiments, the sensor assembly 210 may be utilized to detect one or more of the following: an occlusion in a fluid path that slows, prevents, or otherwise degrades fluid delivery from the reservoir 205 to a user's body; when the reservoir 205 is empty; when the slide 206 is properly seated with the reservoir 205; when a fluid dose has been delivered; when the infusion pump 200 is subjected to shock or vibration; when the infusion pump 200 requires maintenance.

**[0037]** Depending on the embodiment, the fluid-containing reservoir 205 may be realized as a syringe, a vial, a cartridge, a bag, or the like. In certain embodiments, the infused fluid is insulin, although many other fluids may be administered through infusion such as, but not limited to, HIV drugs, drugs to treat pulmonary hypertension, iron chelation drugs, pain medications, anti-cancer treatments, medications, vitamins, hormones, or the like. As best illustrated in FIGS. 3-4, the reservoir 205 typically includes a reservoir barrel 219 that contains the fluid and is concentrically and/or coaxially aligned with the slide 206 (e.g., in the axial direction 218) when the reservoir 205 is inserted into

the infusion pump 200. The end of the reservoir 205 proximate the opening 220 may include or otherwise mate with the fitting 223, which secures the reservoir 205 in the housing 202 and prevents displacement of the reservoir 205 in the axial direction 218 with respect to the housing 202 after the reservoir 205 is inserted into the housing 202. As described above, the fitting 223 extends from (or through) the opening 220 of the housing 202 and mates with tubing 221 to establish fluid communication from the interior of the reservoir 205 (e.g., reservoir barrel 219) to the user via the tubing 221 and infusion set 225. The opposing end of the reservoir 205 proximate the slide 206 includes a plunger 217 (or stopper) positioned to push fluid from inside the barrel 219 of the reservoir 205 along a fluid path through tubing 221 to a user. The slide 206 is configured to mechanically couple or otherwise engage with the plunger 217, thereby becoming seated with the plunger 217 and/or reservoir 205. Fluid is forced from the reservoir 205 via tubing 221 as the drive system 208 is operated to displace the slide 206 in the axial direction 218 toward the opening 220 in the housing 202.

**[0038]** In the illustrated embodiment of FIGS. 3-4, the drive system 208 includes a motor assembly 207 and a drive screw 209. The motor assembly 207 includes a motor that is coupled to drive train components of the drive system 208 that are configured to convert rotational motor motion to a translational displacement of the slide 206 in the axial direction 218, and thereby engaging and displacing the plunger 217 of the reservoir 205 in the axial direction 218. In some embodiments, the motor assembly 207 may also be powered to translate the slide 206 in the opposing direction (e.g., the direction opposite direction 218) to retract and/or detach from the reservoir 205 to allow the reservoir 205 to be replaced. In exemplary embodiments, the motor assembly 207 includes a brushless DC (BLDC) motor having one or more permanent magnets mounted, affixed, or otherwise disposed on its rotor. However, the subject matter described herein is not necessarily limited to use with BLDC motors, and in alternative embodiments, the motor may be realized as a solenoid motor, an AC motor, a stepper motor, a piezoelectric caterpillar drive, a shape memory actuator drive, an electrochemical gas cell, a thermally driven gas cell, a bimetallic actuator, or the like. The drive train components may comprise one or more lead screws, cams, ratchets, jacks, pulleys, pawls, clamps, gears, nuts, slides, bearings, levers, beams, stoppers, plungers, sliders, brackets, guides, bearings, supports, bellows, caps, diaphragms, bags, heaters, or the like. In this regard, although the illustrated embodiment of the infusion pump utilizes a coaxially aligned drive train, the motor could

be arranged in an offset or otherwise non-coaxial manner, relative to the longitudinal axis of the reservoir 205.

**[0039]** As best shown in FIG. 4, the drive screw 209 mates with threads 402 internal to the slide 206. When the motor assembly 207 is powered and operated, the drive screw 209 rotates, and the slide 206 is forced to translate in the axial direction 218. In an exemplary embodiment, the infusion pump 200 includes a sleeve 211 to prevent the slide 206 from rotating when the drive screw 209 of the drive system 208 rotates. Thus, rotation of the drive screw 209 causes the slide 206 to extend or retract relative to the drive motor assembly 207. When the fluid infusion device is assembled and operational, the slide 206 contacts the plunger 217 to engage the reservoir 205 and control delivery of fluid from the infusion pump 200. In an exemplary embodiment, the shoulder portion 215 of the slide 206 contacts or otherwise engages the plunger 217 to displace the plunger 217 in the axial direction 218. In alternative embodiments, the slide 206 may include a threaded tip 213 capable of being detachably engaged with internal threads 404 on the plunger 217 of the reservoir 205, as described in detail in United States patent numbers 6,248,093 and 6,485,465, which are incorporated by reference herein.

**[0040]** As illustrated in FIG. 3, the electronics assembly 204 includes control electronics 224 coupled to the display element 226, with the housing 202 including a transparent window portion 228 that is aligned with the display element 226 to allow the display 226 to be viewed by the user when the electronics assembly 204 is disposed within the interior 214 of the housing 202. The control electronics 224 generally represent the hardware, firmware, processing logic and/or software (or combinations thereof) configured to control operation of the motor assembly 207 and/or drive system 208, as described in greater detail below in the context of FIG. 5. Whether such functionality is implemented as hardware, firmware, a state machine, or software depends upon the particular application and design constraints imposed on the embodiment. Those familiar with the concepts described here may implement such functionality in a suitable manner for each particular application, but such implementation decisions should not be interpreted as being restrictive or limiting. In an exemplary embodiment, the control electronics 224 includes one or more programmable controllers that may be programmed to control operation of the infusion pump 200.

**[0041]** The motor assembly 207 includes one or more electrical leads 236 adapted to be electrically coupled to the electronics assembly 204 to establish communication between the control electronics 224 and the motor assembly 207. In response to command

signals from the control electronics 224 that operate a motor driver (e.g., a power converter) to regulate the amount of power supplied to the motor from a power supply, the motor actuates the drive train components of the drive system 208 to displace the slide 206 in the axial direction 218 to force fluid from the reservoir 205 along a fluid path (including tubing 221 and an infusion set), thereby administering doses of the fluid contained in the reservoir 205 into the user's body. Preferably, the power supply is realized one or more batteries contained within the housing 202. Alternatively, the power supply may be a solar panel, capacitor, AC or DC power supplied through a power cord, or the like. In some embodiments, the control electronics 224 may operate the motor of the motor assembly 207 and/or drive system 208 in a stepwise manner, typically on an intermittent basis; to administer discrete precise doses of the fluid to the user according to programmed delivery profiles.

**[0042]** Referring to FIGS. 2-4, as described above, the user interface 230 includes HMI elements, such as buttons 232 and a directional pad 234, that are formed on a graphic keypad overlay 231 that overlies a keypad assembly 233, which includes features corresponding to the buttons 232, directional pad 234 or other user interface items indicated by the graphic keypad overlay 231. When assembled, the keypad assembly 233 is coupled to the control electronics 224, thereby allowing the HMI elements 232, 234 to be manipulated by the user to interact with the control electronics 224 and control operation of the infusion pump 200, for example, to administer a bolus of insulin, to change therapy settings, to change user preferences, to select display features, to set or disable alarms and reminders, and the like. In this regard, the control electronics 224 maintains and/or provides information to the display 226 regarding program parameters, delivery profiles, pump operation, alarms, warnings, statuses, or the like, which may be adjusted using the HMI elements 232, 234. In various embodiments, the HMI elements 232, 234 may be realized as physical objects (e.g., buttons, knobs, joysticks, and the like) or virtual objects (e.g., using touch-sensing and/or proximity-sensing technologies). For example, in some embodiments, the display 226 may be realized as a touch screen or touch-sensitive display, and in such embodiments, the features and/or functionality of the HMI elements 232, 234 may be integrated into the display 226 and the HMI 230 may not be present. In some embodiments, the electronics assembly 204 may also include alert generating elements coupled to the control electronics 224 and suitably configured to generate one or more types of feedback, such as, without limitation: audible feedback; visual feedback; haptic (physical) feedback; or the like.

[0043] Referring to FIGS. 3-4, in accordance with one or more embodiments, the sensor assembly 210 includes a back plate structure 250 and a loading element 260. The loading element 260 is disposed between the capping member 212 and a beam structure 270 that includes one or more beams having sensing elements disposed thereon that are influenced by compressive force applied to the sensor assembly 210 that deflects the one or more beams, as described in greater detail in United States Patent No. 8,474,332, which is incorporated by reference herein. In exemplary embodiments, the back plate structure 250 is affixed, adhered, mounted, or otherwise mechanically coupled to the bottom surface 238 of the drive system 208 such that the back plate structure 250 resides between the bottom surface 238 of the drive system 208 and the housing cap 216. The drive system capping member 212 is contoured to accommodate and conform to the bottom of the sensor assembly 210 and the drive system 208. The drive system capping member 212 may be affixed to the interior of the housing 202 to prevent displacement of the sensor assembly 210 in the direction opposite the direction of force provided by the drive system 208 (e.g., the direction opposite direction 218). Thus, the sensor assembly 210 is positioned between the motor assembly 207 and secured by the capping member 212, which prevents displacement of the sensor assembly 210 in a downward direction opposite the direction of arrow 218, such that the sensor assembly 210 is subjected to a reactionary compressive force when the drive system 208 and/or motor assembly 207 is operated to displace the slide 206 in the axial direction 218 in opposition to the fluid pressure in the reservoir 205. Under normal operating conditions, the compressive force applied to the sensor assembly 210 is correlated with the fluid pressure in the reservoir 205. As shown, electrical leads 240 are adapted to electrically couple the sensing elements of the sensor assembly 210 to the electronics assembly 204 to establish communication to the control electronics 224, wherein the control electronics 224 are configured to measure, receive, or otherwise obtain electrical signals from the sensing elements of the sensor assembly 210 that are indicative of the force applied by the drive system 208 in the axial direction 218.

[0044] FIG. 5 depicts an exemplary embodiment of a control system 500 suitable for use with an infusion device 502, such as the infusion device 102 in FIG. 1 or the infusion device 200 of FIG. 2. The control system 500 is configured to control or otherwise regulate a physiological condition in the body 501 of a user. In one or more exemplary embodiments, the condition being regulated is sensed, detected, measured or otherwise quantified by a sensing arrangement 504 (e.g., sensing arrangement 104) communicatively coupled to the infusion device 502. However, it should be noted that in alternative

embodiments, the condition being regulated by the control system 500 may be correlative to the measured values obtained by the sensing arrangement 504. That said, for clarity and purposes of explanation, the subject matter may be described herein in the context of the sensing arrangement 504 being realized as a glucose sensing arrangement that senses, detects, measures or otherwise quantifies the user's glucose level, which is being regulated in the body 501 of the user by the control system 500.

**[0045]** In exemplary embodiments, the sensing arrangement 504 includes one or more interstitial glucose sensing elements that generate or otherwise output electrical signals having a signal characteristic that is correlative to, influenced by, or otherwise indicative of the relative interstitial fluid glucose level in the body 501 of the user. The output electrical signals are filtered or otherwise processed to obtain a measurement value indicative of the user's interstitial fluid glucose level. In exemplary embodiments, a blood glucose meter 530, such as a finger stick device, is utilized to directly sense, detect, measure or otherwise quantify the blood glucose in the body 501 of the user. In this regard, the blood glucose meter 530 outputs or otherwise provides a measured blood glucose value that may be utilized as a reference measurement for calibrating the sensing arrangement 504 and converting a measurement value indicative of the user's interstitial fluid glucose level into a corresponding calibrated blood glucose measurement value. For purposes of explanation, sensor glucose value, sensed glucose value, or variants thereof should be understood to encompass any glucose value indicative of a current glucose level in the body of the user that is based on the electrical signals output by the sensing element(s) of the sensing arrangement 504.

**[0046]** The pump control system 520 generally represents the electronics and other components of the infusion device 502 that control operation of the fluid infusion device 502 according to a desired infusion delivery program in a manner that may be influenced by the sensed glucose value indicative of a current glucose level in the body 501 of the user. The particular operating mode being implemented by the pump control system 520 influences the generated dosage commands for operating the motor 507 to displace the plunger 517 and deliver insulin to the body 501 of the user. For example, in a closed-loop (CL) operating mode, the pump control system 520 generates or otherwise determines dosage commands for operating the motor 507 based on the difference between a sensed glucose value and the target (or commanded) glucose value to regulate the sensed glucose value to the target. In other operating modes, the pump control system 520 may generate or otherwise determine dosage commands configured to maintain the sensed glucose value

below an upper glucose limit, above a lower glucose limit, or otherwise within a desired range of glucose values. For example, in a predictive low glucose management (PLGM) operating mode, the pump control system 520 calculates or otherwise determines a predicted glucose value based on the currently sensed glucose value, and generates dosage commands configured to provide a basal infusion rate when the predicted glucose value is greater than a predictive suspend threshold and automatically suspends delivery (e.g., by providing dosage commands equal to zero) when the predicted glucose value is less than the predictive suspend threshold. In a low glucose suspend (LGS) operating mode, the pump control system 520 generates dosage commands configured to provide a basal infusion rate when the sensed glucose value is greater than a suspend threshold (which may be different from the predictive suspend threshold) and automatically suspends delivery when the sensed glucose value is less than the suspend threshold. In an open-loop (OL) operating mode, the pump control system 520 generates dosage commands configured to provide a predetermined open-loop basal infusion rate independent of the sensed glucose value. In practice, the infusion device 502 may store or otherwise maintain the target value, suspension threshold values, and/or other glucose threshold value(s) in a data storage element accessible to the pump control system 520.

[0047] The target glucose value and other threshold values may be received from an external component (e.g., CCD 106 and/or computing device 108) or be input by a user via a user interface element 540 associated with the infusion device 502. In practice, the one or more user interface element(s) 540 associated with the infusion device 502 typically include at least one input user interface element, such as, for example, a button, a keypad, a keyboard, a knob, a joystick, a mouse, a touch panel, a touchscreen, a microphone or another audio input device, and/or the like. Additionally, the one or more user interface element(s) 540 include at least one output user interface element, such as, for example, a display element (e.g., a light-emitting diode or the like), a display device (e.g., a liquid crystal display or the like), a speaker or another audio output device, a haptic feedback device, or the like, for providing notifications or other information to the user. It should be noted that although FIG. 5 depicts the user interface element(s) 540 as being separate from the infusion device 502, in practice, one or more of the user interface element(s) 540 may be integrated with the infusion device 502. Furthermore, in some embodiments, one or more user interface element(s) 540 are integrated with the sensing arrangement 504 in addition to and/or in alternative to the user interface element(s) 540 integrated with the infusion device 502. The user interface element(s) 540 may be

manipulated by the user to operate the infusion device 502 to deliver correction boluses, adjust target and/or threshold values, modify the delivery control scheme or operating mode, and the like, as desired.

**[0048]** In exemplary embodiments, the pump control system 520 includes or otherwise accesses a data storage element, memory, or other non-transitory computer-readable medium capable of storing programming instructions for execution by the pump control system 520. The computer-executable programming instructions, when read and executed, cause the pump control system 520 to determine dosage commands in accordance with a particular operating mode and perform various additional tasks, operations, functions, and processes described herein in the context of FIGS. 7-10.

**[0049]** Still referring to FIG. 5, in the illustrated embodiment, the infusion device 502 includes a motor control module 512 coupled to a motor 507 (e.g., motor assembly 207) that is operable to displace a plunger 517 (e.g., plunger 217) in a reservoir (e.g., reservoir 205) and provide a desired amount of fluid to the body 501 of a user. In this regard, displacement of the plunger 517 results in the delivery of a fluid that is capable of influencing the condition in the body 501 of the user to the body 501 of the user via a fluid delivery path (e.g., via tubing 221 of an infusion set 225). A motor driver module 514 is coupled between an energy source 503 and the motor 507. The motor control module 512 is coupled to the motor driver module 514, and the motor control module 512 generates or otherwise provides command signals that operate the motor driver module 514 to provide current (or power) from the energy source 503 to the motor 507 to displace the plunger 517 in response to receiving, from a pump control system 520, a dosage command indicative of the desired amount of fluid to be delivered.

**[0050]** In exemplary embodiments, the energy source 503 is realized as a battery housed within the infusion device 502 (e.g., within housing 202) that provides direct current (DC) power. In this regard, the motor driver module 514 generally represents the combination of circuitry, hardware and/or other electrical components configured to convert or otherwise transfer DC power provided by the energy source 503 into alternating electrical signals applied to respective phases of the stator windings of the motor 507 that result in current flowing through the stator windings that generates a stator magnetic field and causes the rotor of the motor 507 to rotate. The motor control module 512 is configured to receive or otherwise obtain a commanded dosage from the pump control system 520, convert the commanded dosage to a commanded translational displacement of the plunger 517, and command, signal, or otherwise operate the motor driver module 514

to cause the rotor of the motor 507 to rotate by an amount that produces the commanded translational displacement of the plunger 517. For example, the motor control module 512 may determine an amount of rotation of the rotor required to produce translational displacement of the plunger 517 that achieves the commanded dosage received from the pump control system 520. Based on the current rotational position (or orientation) of the rotor with respect to the stator that is indicated by the output of the rotor sensing arrangement 516, the motor control module 512 determines the appropriate sequence of alternating electrical signals to be applied to the respective phases of the stator windings that should rotate the rotor by the determined amount of rotation from its current position (or orientation). In embodiments where the motor 507 is realized as a BLDC motor, the alternating electrical signals commutate the respective phases of the stator windings at the appropriate orientation of the rotor magnetic poles with respect to the stator and in the appropriate order to provide a rotating stator magnetic field that rotates the rotor in the desired direction. Thereafter, the motor control module 512 operates the motor driver module 514 to apply the determined alternating electrical signals (e.g., the command signals) to the stator windings of the motor 507 to achieve the desired delivery of fluid to the user.

**[0051]** When the motor control module 512 is operating the motor driver module 514, current flows from the energy source 503 through the stator windings of the motor 507 to produce a stator magnetic field that interacts with the rotor magnetic field. In some embodiments, after the motor control module 512 operates the motor driver module 514 and/or motor 507 to achieve the commanded dosage, the motor control module 512 ceases operating the motor driver module 514 and/or motor 507 until a subsequent dosage command is received. In this regard, the motor driver module 514 and the motor 507 enter an idle state during which the motor driver module 514 effectively disconnects or isolates the stator windings of the motor 507 from the energy source 503. In other words, current does not flow from the energy source 503 through the stator windings of the motor 507 when the motor 507 is idle, and thus, the motor 507 does not consume power from the energy source 503 in the idle state, thereby improving efficiency.

**[0052]** Depending on the embodiment, the motor control module 512 may be implemented or realized with a general purpose processor, a microprocessor, a controller, a microcontroller, a state machine, a content addressable memory, an application specific integrated circuit, a field programmable gate array, any suitable programmable logic device, discrete gate or transistor logic, discrete hardware components, or any combination

thereof, designed to perform the functions described herein. Furthermore, the steps of a method or algorithm described in connection with the embodiments disclosed herein may be embodied directly in hardware, in firmware, in a software module executed by the motor control module 512, or in any practical combination thereof. In exemplary embodiments, the motor control module 512 includes or otherwise accesses a data storage element or memory, including any sort of random access memory (RAM), read only memory (ROM), flash memory, registers, hard disks, removable disks, magnetic or optical mass storage, or any other short or long term storage media or other non-transitory computer-readable medium, which is capable of storing programming instructions for execution by the motor control module 512. The computer-executable programming instructions, when read and executed by the motor control module 512, cause the motor control module 512 to perform the tasks, operations, functions, and processes described herein.

**[0053]** It should be appreciated that FIG. 5 is a simplified representation of the infusion device 502 for purposes of explanation and is not intended to limit the subject matter described herein in any way. In this regard, depending on the embodiment, some features and/or functionality of the sensing arrangement 504 may be implemented by or otherwise integrated into the pump control system 520, or vice versa. Similarly, in practice, the features and/or functionality of the motor control module 512 may be implemented by or otherwise integrated into the pump control system 520, or vice versa. Furthermore, the features and/or functionality of the pump control system 520 may be implemented by control electronics 224 located in the fluid infusion device 200, while in alternative embodiments, the pump control system 520 may be implemented by a remote computing device that is physically distinct and/or separate from the infusion device 502, such as, for example, the CCD 106 or the computing device 108.

**[0054]** FIG. 6 depicts an exemplary embodiment of a pump control system 600 suitable for use as the pump control system 520 in FIG. 5 in accordance with one or more embodiments. The illustrated pump control system 600 includes, without limitation, a pump control module 602, a communications interface 604, and a data storage element (or memory) 606. The pump control module 602 is coupled to the communications interface 604 and the memory 606, and the pump control module 602 is suitably configured to support the operations, tasks, and/or processes described herein. In exemplary embodiments, the pump control module 602 is also coupled to one or more user interface elements 608 (e.g., user interface 230, 540) for receiving bolus or other delivery

instructions and providing notifications or other information to the user. Although FIG. 6 depicts the user interface element 608 as being integrated with the pump control system 600 (e.g., as part of the infusion device 200, 502), in various alternative embodiments, the user interface element 608 may be integrated with the sensing arrangement 504 or another element of an infusion system 100 (e.g., the computer 108 or CCD 106).

[0055] Referring to FIG. 6 and with reference to FIG. 5, the communications interface 604 generally represents the hardware, circuitry, logic, firmware and/or other components of the pump control system 600 that are coupled to the pump control module 602 and configured to support communications between the pump control system 600 and the sensing arrangement 504. In this regard, the communications interface 604 may include or otherwise be coupled to one or more transceiver modules capable of supporting wireless communications between the pump control system 520, 600 and the sensing arrangement 504 or another electronic device 106, 108 in an infusion system 100. In other embodiments, the communications interface 604 may be configured to support wired communications to/from the sensing arrangement 504.

[0056] The pump control module 602 generally represents the hardware, circuitry, logic, firmware and/or other component of the pump control system 600 that is coupled to the communications interface 604 and configured to determine dosage commands for operating the motor 507 to deliver fluid to the body 501 based on data received from the sensing arrangement 504 and perform various additional tasks, operations, functions and/or operations described herein. For example, in exemplary embodiments, pump control module 602 implements or otherwise executes a command generation module 614 that automatically calculates or otherwise determines a dosage command for operating the motor 507 of the infusion device 502 in accordance with a particular operating mode. In exemplary embodiments described herein, the command generation module 614 supports multiple different operating modes having different delivery control schemes associated therewith. Additionally, the command generation module 614 may generate dosage commands for delivering boluses that are manually-initiated or otherwise instructed by a user via a user interface element 608. The illustrated pump control module 602 also implements or otherwise executes a diagnostics module 612 that generates or otherwise provides user notifications or alerts via a user interface element 608. As described in greater detail below in the context of FIG. 8, in exemplary embodiments, the diagnostics module 612 determines the viability of a particular operating mode in advance of a subsequent instance of that operating mode and generates notifications via the user

interface element 608 that indicate recommended remedial actions to improve the viability of that operating mode.

**[0057]** Still referring to FIG. 6, depending on the embodiment, the pump control module 602 may be implemented or realized with a general purpose processor, a microprocessor, a controller, a microcontroller, a state machine, a content addressable memory, an application specific integrated circuit, a field programmable gate array, any suitable programmable logic device, discrete gate or transistor logic, discrete hardware components, or any combination thereof, designed to perform the functions described herein. In this regard, the steps of a method or algorithm described in connection with the embodiments disclosed herein may be embodied directly in hardware, in firmware, in a software module executed by the pump control module 602, or in any practical combination thereof. In exemplary embodiments, the pump control module 602 includes or otherwise accesses the data storage element or memory 606, which may be realized using any sort of non-transitory computer-readable medium capable of storing programming instructions for execution by the pump control module 602. The computer-executable programming instructions, when read and executed by the pump control module 602, cause the pump control module 602 to perform the tasks, operations, functions, and processes described in greater detail below.

**[0058]** It should be understood that FIG. 6 is a simplified representation of a pump control system 600 for purposes of explanation and is not intended to limit the subject matter described herein in any way. For example, in some embodiments, the features and/or functionality of the motor control module 512 may be implemented by or otherwise integrated into the pump control system 600 and/or the pump control module 602, for example, by the command generation module 614 converting the dosage command into a corresponding motor command, in which case, the separate motor control module 512 may be absent from an embodiment of the infusion device 502.

**[0059]** FIG. 7 depicts an exemplary closed-loop control system 700 that may be implemented by a pump control system 520, 600 to regulate a condition in the body of a user to a desired (or target) value. It should be appreciated that FIG. 7 is a simplified representation of the control system 700 for purposes of explanation and is not intended to limit the subject matter described herein in any way.

**[0060]** In exemplary embodiments, the control system 700 receives or otherwise obtains a target glucose value at input 702. In some embodiments, the target glucose value may be stored or otherwise maintained by the infusion device 502 (e.g., in memory 606),

however, in some alternative embodiments, the target value may be received from an external component (e.g., CCD 106 and/or computer 108). In one or more embodiments, the target glucose value may be dynamically calculated or otherwise determined prior to entering the closed-loop operating mode based on one or more patient-specific control parameters. For example, the target blood glucose value may be calculated based at least in part on a patient-specific reference basal rate and a patient-specific daily insulin requirement, which are determined based on historical delivery information over a preceding interval of time (e.g., the amount of insulin delivered over the preceding 24 hours). The control system 700 also receives or otherwise obtains a current glucose measurement value from the sensing arrangement 504 at input 704. The illustrated control system 700 implements or otherwise provides proportional-integral-derivative (PID) control to determine or otherwise generate delivery commands for operating the motor 510 based at least in part on the difference between the target glucose value and the current glucose measurement value. In this regard, the PID control attempts to minimize the difference between the measured value and the target value, and thereby regulates the measured value to the desired value. PID control parameters are applied to the difference between the target glucose level at input 702 and the measured glucose level at input 704 to generate or otherwise determine a dosage (or delivery) command provided at output 730. Based on that delivery command, the motor control module 512 operates the motor 510 to deliver insulin to the body of the user to influence the user's glucose level, and thereby reduce the difference between a subsequently measured glucose level and the target glucose level.

**[0061]** The illustrated control system 700 includes or otherwise implements a summation block 706 configured to determine a difference between the target value obtained at input 702 and the measured value obtained from the sensing arrangement 504 at input 704, for example, by subtracting the target value from the measured value. The output of the summation block 706 represents the difference between the measured and target values, which is then provided to each of a proportional term path, an integral term path, and a derivative term path. The proportional term path includes a gain block 720 that multiplies the difference by a proportional gain coefficient,  $K_P$ , to obtain the proportional term. The integral term path includes an integration block 708 that integrates the difference and a gain block 722 that multiplies the integrated difference by an integral gain coefficient,  $K_I$ , to obtain the integral term. The derivative term path includes a derivative block 710 that determines the derivative of the difference and a gain block 724 that

multiplies the derivative of the difference by a derivative gain coefficient,  $K_D$ , to obtain the derivative term. The proportional term, the integral term, and the derivative term are then added or otherwise combined to obtain a delivery command that is utilized to operate the motor at output 730. Various implementation details pertaining to closed-loop PID control and determine gain coefficients are described in greater detail in United States patent number 7,402,153, which is incorporated by reference.

**[0062]** In one or more exemplary embodiments, the PID gain coefficients are user-specific (or patient-specific) and dynamically calculated or otherwise determined prior to entering the closed-loop operating mode based on historical insulin delivery information (e.g., amounts and/or timings of previous dosages, historical correction bolus information, or the like), historical sensor measurement values, historical reference blood glucose measurement values, user-reported or user-input events (e.g., meals, exercise, and the like), and the like. In this regard, one or more patient-specific control parameters (e.g., an insulin sensitivity factor, a daily insulin requirement, an insulin limit, a reference basal rate, a reference fasting glucose, an active insulin action duration, pharmacodynamical time constants, or the like) may be utilized to compensate, correct, or otherwise adjust the PID gain coefficients to account for various operating conditions experienced and/or exhibited by the infusion device 502. The PID gain coefficients may be maintained by the memory 606 accessible to the pump control module 602. In this regard, the memory 606 may include a plurality of registers associated with the control parameters for the PID control. For example, a first parameter register may store the target glucose value and be accessed by or otherwise coupled to the summation block 706 at input 702, and similarly, a second parameter register accessed by the proportional gain block 720 may store the proportional gain coefficient, a third parameter register accessed by the integration gain block 722 may store the integration gain coefficient, and a fourth parameter register accessed by the derivative gain block 724 may store the derivative gain coefficient.

**[0063]** FIG. 8 depicts an exemplary transition diagnosis process 800 suitable for implementation by a control system associated with a fluid infusion device to determine whether transitioning into a particular operating mode at some subsequent time is viable. For purposes of explanation, the transition diagnosis process 800 may be described herein in the context of a closed-loop operating mode, for example, a transition from open-loop mode to closed-loop mode. It will be appreciated that the subject matter described herein is not limited to the particular destination operating mode being diagnosed. It could, for example, represent the change from a closed-loop mode to a predictive low glucose

management (PLGM) mode. Various tasks performed in connection with the transition diagnosis process 800 may be performed by hardware, firmware, software executed by processing circuitry, or any combination thereof. For illustrative purposes, the following description refers to elements mentioned above in connection with FIGS. 1-7. In practice, portions of the transition diagnosis process 800 may be performed by different elements of the control system 500, such as, for example, the infusion device 502, the pump control system 520, 600, the diagnostics module 612, the command generation module 614 and/or the user interface 540, 608. It should be appreciated that the transition diagnosis process 800 may include any number of additional or alternative tasks, the tasks need not be performed in the illustrated order and/or the tasks may be performed concurrently, and/or the transition diagnosis process 800 may be incorporated into a more comprehensive procedure or process having additional functionality not described in detail herein. Moreover, one or more of the tasks shown and described in the context of FIG. 8 could be omitted from a practical embodiment of the transition diagnosis process 800 as long as the intended overall functionality remains intact.

**[0064]** The transition diagnosis process 800 illustrated in Fig. 8 takes place when it is intended to change the fluid delivery control from one mode, for example, open-loop, to another mode, for example, closed-loop. This intention may be communicated to the system via a user interface, and may be one-off, for example, the selection of a setting on an insulin pump “tonight we want to implement a night time regime” or a continuously maintained setting such as “implement night-day regimes”. This choice will be made before the start of the procedures set out in Fig. 8. Once the choice that a transition will occur, the transition diagnosis process 800 initializes or otherwise begins by obtaining operational information pertaining to one or more prior instances of the operating mode being analyzed and calculates or otherwise determines an expected start time and an expected duration of the next subsequent instance of the operating mode based on the operational information for the prior instances (tasks 802, 804). This is perhaps best illustrated by the example of a transition to closed-loop mode occurring in an insulin pump when a user goes to bed each evening. In this case the start time will be the time that the user confirms to the pump that the night time regime should start. The closed-loop mode will continue until cancelled in the morning by the user or by a time-out or other intervention. The night regime is a repeating event, thus giving rise to consecutive instances of the closed-loop operating mode each with a start time (e.g., 10 p.m.) and each with a duration (e.g., 8 hours). By recording these start times and durations the pump

acquires historic operational information pertaining to prior instances of the operating mode (in this case closed-loop). The historic information can also include the times, and cause of, any malfunction that may occur. Thus, the pump control system 520, 600 may store or otherwise maintain historical information pertaining to the previous operation of the infusion device 502 that characterizes prior instances of the different operating modes supported by the pump control system 520, 600. For example, the pump control system 520 may store or otherwise maintain operational information indicative of the respective start times of prior instances of the closed-loop operating mode along with the respective durations (or stop times) of prior instances of the closed-loop operating mode. The exact time of executing task 802 (retrieving historic operational information) is unimportant except that it preferably is sufficiently prior to the events to be described below as not to interfere with them. Also, it can be repeated so that the operational information about prior instances is always present once the decision to transition to the subsequent instance of the operating mode has been made. Based on this historical operational information maintained for the closed-loop operating mode, the pump control system 520, 600 and/or diagnostics module 612 may determine an expected (or anticipated) start time for a subsequent instance of the closed-loop operating mode along with an expected duration for the subsequent instance of the closed-loop operating mode. For example, the expected start time may be calculated by averaging the individual start times for preceding instances of the closed-loop operating mode, and the expected duration may be calculated by averaging the respective durations of preceding instances of the closed-loop operating mode. Alternatively, the expected start time could be a user input. In that case the historic data may optionally be used to predict a likely variation in the start time.

**[0065]** In exemplary embodiments, the transition diagnosis process 800 calculates or otherwise determines a buffer time before the subsequent instance of the destination operating mode is expected to be initiated (task 806). Typically, the buffer time will be stored in a memory of the diagnostics unit 612 in a look-up table correlating buffer time with operating mode. The buffer time is a time duration representing the amount of time in advance of the expected start time for analyzing the future viability of entering the destination operating mode at the expected start time. In exemplary embodiments, the buffer time is determined so that it also provides sufficient time for remedial actions to be undertaken to improve the viability the destination operating mode by the expected start time. For example, calculating the PID control parameters for the closed-loop operating mode may require a certain amount of reference blood glucose measurements, sensor

measurement data, insulin delivery information, or the like. Accordingly, when the destination operating mode is the closed-loop operating mode, the buffer time is chosen to provide enough time between the diagnostics checks and the expected start time for the next instance of the closed-loop operating mode to allow the required amount of data for calculating the PID control parameters to be obtained by the expected start time. In this regard, the buffer time may vary depending on the particular destination operating mode being analyzed and the respective algorithmic diagnostic checks to be performed for that particular operating mode. For example, the buffer time for the closed-loop operating mode may be greater than the buffer time for a LGS operating mode due to the calculation of the closed-loop PID control parameters requiring a greater amount of underlying data than the LGS operating mode control parameters. In one embodiment, a five hour buffer time is utilized for the closed-loop operating mode to ensure historical delivery information sufficient for calculating patient-specific control parameters will likely exist at the expected start time for the closed-loop operating mode.

**[0066]** Additionally, the buffer time may vary dynamically depending on the iteration of the diagnosis process 800. For example, if previous iterations of the diagnosis process 800 have already determined that aspects of the destination operating mode that require a longer buffer time are unlikely to impact the future viability of the operating mode (e.g., sufficient historical data is available), the buffer time may be reduced for subsequent iterations of the diagnosis process 800. In one or more embodiments, where the diagnostics module 612 analyzes the viability of the sensing arrangement 504 as part of determining the viability for the next instance of the destination operating mode, the buffer time is determined to be greater than or equal to a minimum amount of time required to calibrate the sensing arrangement 504. In this regard, if a reliability or accuracy metric associated with the sensing arrangement 504 indicates a sensing element should be replaced, the buffer time ensures that there will be enough time to calibrate the sensing arrangement 504 with a new sensing element before the expected start time. In one embodiment, a minimum buffer time of two hours may be implemented.

**[0067]** The diagnosis process 800 continues by automatically identifying or otherwise determining when to begin analyzing the viability of the destination operating mode based on the buffer time and the expected start time (task 808). The point in time at which this viability analysis starts is referred to as the diagnosis time. It can either be computed as the buffer time prior to the expected start time, with the viability checks starting when that time arrives. Alternatively, having determined the buffer time a periodic check can be

made of the sum of the current time and the buffer time. When this sum equals the expected start time the viability tests can start. This is task 808 shown in Fig. 8. Thus, at the buffer time before the expected start time, the diagnosis process 800 obtains status information for the operation of the infusion device and calculates or otherwise determines viability of a subsequent instance of the operating mode based at least in part on that status information (tasks 810, 812). When one or more of the physical or algorithmic diagnostics checks indicates the destination operating mode is unlikely to be viable at the expected start time for the expected duration, the diagnosis process 800 automatically generates or otherwise provides one or more user notifications indicative of recommended remedial actions for improving the future viability of the operating mode (tasks 814, 816). In this regard, the diagnostics module 612 operates a user interface 540, 608 to provide indication of a remedial action that the user can perform to increase the likelihood that the operating mode will be viable at the expected start time.

**[0068]** In exemplary embodiments, the diagnostics module 612 automatically obtains clinical and physical status information pertaining to the current and/or previous operation of the infusion device 502 from the memory 606, such as, historical delivery data (e.g., timing and amounts of correction boluses, daily insulin delivered, etc.), blood glucose reference measurement data (e.g., measurement values obtained from blood glucose meter 530 and the corresponding times of measurement), sensor calibration data (e.g., current and/or previous calibration factors), recent sensor measurement data, the current status of the energy source 503 (e.g., the current battery level), the current amount of fluid remaining in the reservoir, and the like. The diagnostics module 612 analyzes the status information and determines the viability of the destination operating mode for the expected duration of the next instance of the destination operating mode. When one or more aspects of the status information fail to satisfy a respective viability criterion, the diagnostics module 612 determines that the operating mode is unlikely to be viable at the expected start time for the expected duration.

**[0069]** In exemplary embodiments, the diagnostics module 612 determines whether implementing the destination operating mode at the expected start time for the expected duration is viable from a physical perspective. In this regard, the diagnostics module 612 performs a number of physical diagnostics checks to verify the infusion device 502 is physically capable of implementing the destination operating mode at the expected start time for the expected duration. For example, the diagnostics module 612 may calculate or otherwise determine an expected amount of power consumption for the infusion device

502 over the sum of the remaining buffer time before the expected start time and the expected duration, and identifies or otherwise determines the infusion device 502 is not viable for the destination operating mode when the current battery level is less than the expected amount of power consumption. In this regard, the diagnostics module 612 effectively determines whether a low battery alert that could disrupt or otherwise degrade the user experience is likely to be generated by the infusion device 502 during the expected duration of the destination operating mode.

**[0070]** Similarly, the diagnostics module 612 may calculate an expected amount of insulin that will be delivered by the infusion device 502 over the sum of the remaining buffer time before the expected start time and the expected duration based on the historical delivery data and the user's recent sensor glucose measurement value(s), and determines the infusion device 502 is not viable for the destination operating mode when the current amount of insulin remaining is less than the expected amount of insulin to be delivered. Thus, the diagnostics module 612 effectively determines whether a low fluid alert is likely to be generated by the infusion device 502 at some point during the expected duration of the destination operating mode. The diagnostics module 612 may also determine whether any other critical alerts are likely to be generated during the expected duration or whether any events or conditions are likely to occur that would result in the destination operating mode automatically being terminated during the expected duration. In such embodiments, the diagnostics module 612 determines the infusion device 502 is not viable for the destination operating mode when it is determined that a critical alert (or alternatively, a number of alerts exceeding a maximum alert threshold) or an automatic exit event is likely to occur during the expected duration.

**[0071]** In one or more embodiments, the diagnostics module 612 may also calculate or otherwise determine the viability of the sensing arrangement 504 for the expected duration. For example, the diagnostics module 612 may calculate or otherwise determine one or more reliability or accuracy metrics associated with the sensing arrangement 504 based on recent sensor measurement values, blood glucose reference measurement values and/or other calibration information. The diagnostics module 612 determines a projected reliability or accuracy metrics during the expected duration, and identifies or otherwise determines the sensing arrangement 504 is not viable for the destination operating mode when the value of a projected metric is less than a replacement threshold value at any point during the expected duration. In this regard, the diagnostics module 612 effectively determines whether a replace sensor alert that could disrupt or otherwise degrade the user

experience is likely to be generated by the infusion device 502 at some point during the expected duration. In other embodiments, the diagnostics module 612 may determine the sensing arrangement 504 is not viable for the destination operating mode if a difference between the current sensor glucose measurement value and a predicted glucose value is greater than a threshold value, a calibration factor for the sensing arrangement 504 will have expired by the expected start time, communications with the sensing arrangement 504 are deteriorating (e.g., based on an increasing number or frequency of dropouts in communications over a preceding time interval), a difference between the current calibration factor and the preceding calibration factor is greater than a threshold amount (e.g., a difference of more than 35%), or a difference between reference blood glucose measurement value and the corresponding sensor measurement value used for the current calibration factor is greater than a threshold amount (e.g., the sensor measurement value is more than 35% greater than or less than the reference blood glucose measurement value). Additionally, in some embodiments, the diagnostics module 612 may obtain a current battery level for the sensing arrangement 504, determine an expected amount of power consumption for the sensing arrangement 504 over the sum of the remaining buffer time before the expected start time and the expected duration, and determine the sensing arrangement 504 is not viable when its current battery level is less than that expected amount of power consumption.

**[0072]** Additionally, the diagnostics module 612 performs a number of algorithmic diagnostics checks to determine the availability of the destination operating mode at the expected start time. In this regard, the diagnostics module 612 determines the destination operating mode is likely to be unavailable if one or more control parameters relied on by the delivery control scheme of the destination operating mode cannot be calculated, determined, or otherwise obtained at the expected start time. Thus, if insufficient data exists for calculating a particular control parameter, the diagnostics module 612 may determine that the destination operating mode is likely to be unavailable, and therefore not viable. For example, in one embodiment, the closed-loop operating mode utilizes a maximum output insulin infusion rate (U/hr) that is calculated based on the user's total daily insulin dose. When the diagnostics module 612 determines that the less than two consecutive preceding days total daily insulin dose information exists, the diagnostics module 612 determines that the closed-loop operating mode likely will not be viable at the expected start time without a valid maximum output insulin infusion rate. In such situations, the diagnostics module 612 may generate a user notification to manually input a

maximum output insulin infusion rate (or alternatively, a total daily insulin dose). Thus, if the user would like to implement the closed-loop operating mode at a subsequent time but is unsure of how to proceed, the user may contact his or her doctor or other healthcare provider for assistance in determining the maximum output insulin infusion rate (or total daily insulin dose) that is most likely to suit the user's individual needs and insulin response.

**[0073]** In exemplary embodiments, the diagnostics module 612 also determines whether the control parameters will be valid for the entirety of the expected duration of the next instance of the operating mode, and the diagnostics module 612 determines the destination operating mode is not likely to be viable if a control parameter relied on by the delivery control scheme is likely to become invalid at some point during the expected duration. For example, the diagnostics module 612 may determine an infusion rate calculated based on predicted sensor glucose values will be invalid during the expected duration based on the expected rate or frequency of communications dropouts between the infusion device 502 and the sensing arrangement 504.

**[0074]** In the case of a physical diagnostics check indicating the implementation of the operating mode may not be viable for the expected duration, the diagnostics module 612 recommends actions that the user can perform to help ensure the infusion device 502 and the sensing arrangement 504 will be physically capable of implementing the operating mode for the expected duration by the expected start time. For example, when the diagnostics module 612 determines the energy source 503 will likely be unable to provide the expected amount of power consumption by the infusion device 502 throughout the buffer time and the expected duration, the diagnostics module 612 may generate or otherwise provide an indication on a display device 540, 608 that recommends the user recharge or replace the energy source 503. Thus, in advance of the expected start time, the user may initiate replenishment of the energy source 503 so that its state of charge (or power capability) at the expected start time exceeds the expected power consumption over the expected duration. Similarly, when the diagnostics module 612 determines the fluid level of the reservoir is likely too low to provide the expected amount of insulin that will need to be delivered over the buffer time and the expected duration, the diagnostics module 612 may generate or otherwise provide an indication on a display device 540, 608 that recommends the user refill or replace the fluid reservoir. Thus, in advance of the expected start time, the user may replenish the reservoir of the infusion device 502 so that the amount of insulin onboard the infusion device 502 at the expected start time exceeds

the expected insulin delivery over the expected duration. Likewise, when the diagnostics module 612 determines the sensing arrangement 504 is likely to require replacement, recalibration, or recharging, the diagnostics module 612 may generate or otherwise provide the appropriate notification to the user so that the user may recharge the sensing arrangement 504, replace the sensing element of the sensing arrangement 504, recalibrate the sensing arrangement 504, or the like.

**[0075]** Likewise, in the case of an algorithmic diagnostics check indicating the implementation of the operating mode may not be viable, the diagnostics module 612 recommends actions that the user can perform to help ensure the valid control parameters for the delivery control scheme associated with the destination operating mode will be able to be calculated at the expected start time. For example, if calculating a control parameter requires a particular number of blood glucose measurement values (or a particular number of pairs of blood glucose measurement values and sensor glucose measurement values) over a preceding interval of time (e.g., the prior 12 hours) the diagnostics module 612 may generate or otherwise provide an indication to the user to obtain one or more blood glucose measurement values via the blood glucose meter 530, so that the amount of blood glucose measurement data required for calculating that control parameter will be maintained by the infusion device 502 (e.g., in memory 606) at the expected start time. In one embodiment, the diagnostics module 612 generates a notification to obtain a new blood glucose measurement value via the blood glucose meter 530 in response to determining that no reference blood glucose measurement value within 12 hours of the expected start time is currently available.

**[0076]** In one embodiment, algorithmic diagnostics checks to determine the availability of the destination operating mode at the expected start time based on an expected duration of operation in another operating mode (e.g., which may be the current operating mode). For example, if the user is returning from a pump vacation or other period of non-operation, it may be required that the infusion device 502 be operated in an open-loop operating mode for a minimum period of time (e.g., 5 hours) to support calculating a plasma insulin estimate and/or other patient-specific parameters at the expected start time. In this regard, the buffer time may be chosen to be greater than or equal to the minimum period of time for the open-loop operating mode, and the diagnostics module 612 may generate or otherwise provide an indication to the user to operate the infusion device 502 in the open-loop operating mode when the amount of time that the infusion device 502 has been operated in the open-loop operating mode is less

than the minimum period of time. In this regard, when the infusion device 502 is currently in the open-loop operating mode but has not been operated for the minimum period of time, the diagnostics module 612 may calculate or otherwise determine an amount of time required to achieve the minimum period of time and generate or otherwise provide a notification to the user that indicates how much longer the user should maintain the infusion device 502 in the open-loop operating mode.

[0077] Still referring to FIG. 8, in the illustrated embodiment, when the diagnosis process 800 determines that the destination operating mode is likely to be viable at the expected start time for the expected duration, the diagnosis process 800 may also automatically generate or otherwise provides an indication of the future viability of the operating mode (task 818). For example, the diagnostics module 612 may operate a user interface 540, 608 to provide indication of the viability of the operating mode. In this regard, in situations where the destination operating mode is manually-initiated, the user is provided with a notification that lets the user know that the destination operating mode should be available to be initiated as desired. Likewise, in situations where the diagnosis process 800 determines that the user has sufficiently performed the recommended remedial action(s), the diagnosis process 800 may automatically clear or otherwise remove the notification(s) indicating the recommended remedial action(s) and provide another notification that indicates the viability of the operating mode (task 820). In this regard, the diagnostics module 612 may detect or otherwise identify when the user has initiated a remedial action, and in response, repeat the corresponding diagnostic check(s) to ensure that the remedial action has resolved any viability concerns. For example, if the diagnostics module 612 may detect or otherwise verify that the energy source 503 is sufficiently charged, the reservoir contains a sufficient amount of insulin, the sensing arrangement 504 is sufficiently charged and/or calibrated, and/or the like before automatically clearing the recommendations and providing indication that entering the operating mode is now viable. Similarly, the diagnostics module 612 may periodically analyze the historical delivery data, blood glucose measurement data, sensor calibration data, and the like maintained in memory 606 and detect or otherwise verify that all of the control parameters can be determined before automatically providing indication that the operating mode is now viable.

[0078] It should be noted that in some embodiments, after the next instance of the destination operating mode is initiated, the diagnostics module 612 may periodically perform the physical and algorithmic diagnostic checks while the operating mode is being

implemented to verify the continued viability of the operating mode (e.g., tasks 810, 812, 814). In such embodiments, when the diagnostics module 612 determines that the operating mode may not be viable, the diagnostics module 612 may generate or otherwise provide the appropriate recommendations to the user (e.g., task 816) so that the user may improve the future viability of the operating mode before any critical alerts are generated or before the operating mode must be terminated. Additionally, it should be noted that the operational information for the next instance of the destination operating mode may be stored or otherwise maintained for use in determining an updated expected start time and an updated expected duration during the next iteration of the diagnosis process 800 for the next subsequent instance of the operating mode (e.g., tasks 802, 804). In this regard, the expected start time, the expected duration and/or the buffer time may vary dynamically during operation of the infusion device 502 to adapt to changes in the user's usage of the particular operating mode.

**[0079]** In one exemplary embodiment, the diagnosis process 800 is performed for a closed-loop operating mode that the user operates the infusion device 502 in overnight while he or she is sleeping. For example, at bedtime, the user may manipulate the user interface 540, 608 to initiate the closed-loop operating mode to regulate the user's blood glucose while the user is sleeping. In this regard, the infusion device 502 may store or otherwise maintain historical operational information for the overnight closed-loop operating mode, such as, for example, the respective starting times at which the closed-loop operating mode is initiated along with the respective durations or times at which the closed-loop operating mode is terminated (e.g., when the user wakes up in the morning or the operating mode times out). Accordingly, during the day prior to a subsequent instance of the closed-loop operating mode, the diagnostics module 612 and/or the diagnosis process 800 may calculate or otherwise determine the user's average bedtime (e.g., by averaging the respective start times of the recent instances of the operating mode) and the average duration of the operating mode (e.g., the average amount of time the user sleeps) (e.g., tasks 802, 804). Thereafter, the diagnostics module 612 and/or the diagnosis process 800 automatically performs the diagnostics checks the buffer time before the user's average bedtime (e.g., tasks 808, 810, 812) to ensure that the overnight closed-loop operating mode will be available at the time the user is likely to go to bed. For example, if the average bedtime for the user is at 10 P.M. and the buffer time is determined to be five hours, the diagnostics module 612 and/or the diagnosis process 800 automatically performs the diagnostics checks at 5 P.M. to provide notifications of recommended actions

for the user to increase the viability or availability of the overnight closed-loop operating mode (e.g., obtain a new blood glucose reference measurement value, replace or recalibrate the sensing arrangement 504, and the like).

**[0080]** To briefly summarize, the subject matter described herein facilitates transitioning between operating modes in a manner that enhances the user experience (e.g., by enabling the user to proactively increase viability of a desired operating mode and/or excluding operating modes that are likely to generate alerts from possible destinations for automatic transitions) and ensures compliance with applicable delivery control rules and other constraints (e.g., by excluding operating modes that are otherwise likely to result in a violation and transferring timer and/or counter values across operating modes).

**[0081]** For the sake of brevity, conventional techniques related to glucose sensing and/or monitoring, closed-loop glucose control, predictive glucose management, sensor calibration and/or compensation, and other functional aspects of the subject matter may not be described in detail herein. In addition, certain terminology may also be used in the herein for the purpose of reference only, and thus is not intended to be limiting. For example, terms such as “first”, “second”, and other such numerical terms referring to structures do not imply a sequence or order unless clearly indicated by the context. The foregoing description may also refer to elements or nodes or features being “connected” or “coupled” together. As used herein, unless expressly stated otherwise, “coupled” means that one element/node/feature is directly or indirectly joined to (or directly or indirectly communicates with) another element/node/feature, and not necessarily mechanically.

**[0082]** While at least one exemplary embodiment has been presented in the foregoing detailed description, it should be appreciated that a vast number of variations exist. It should also be appreciated that the exemplary embodiment or embodiments described herein are not intended to limit the scope, applicability, or configuration of the claimed subject matter in any way. For example, the subject matter described herein is not limited to the infusion devices and related systems described herein. Moreover, the foregoing detailed description will provide those skilled in the art with a convenient road map for implementing the described embodiment or embodiments. It should be understood that various changes can be made in the function and arrangement of elements without departing from the scope defined by the claims, which includes known equivalents and foreseeable equivalents at the time of filing this patent application. Accordingly, details of the exemplary embodiments or other limitations described above should not be read into the claims absent a clear intention to the contrary.

The following paragraphs set out further embodiments forming part of the present disclosure.

Paragraph 1. A method of operating an infusion device to deliver fluid to a user in accordance with an operating mode, the method comprising:

- obtaining operational information pertaining to one or more prior instances of the operating mode;

- obtaining status information pertaining to the infusion device;

- determining a diagnosis time based at least in part on the operational information, the diagnosis time being prior to a subsequent instance of the operating mode;

- automatically determining viability of the subsequent instance of the operating mode based at least in part on the status information at the diagnosis time; and

- automatically generating a notification indicative of a recommended action for the user based at least in part on the viability.

Paragraph 2. The method of paragraph 1, the status information including glucose measurement data for the user, wherein automatically determining the viability at the diagnosis time comprises determining whether one or more control parameters for the operating mode can be calculated based on the glucose measurement data.

Paragraph 3. The method of paragraph 2, wherein automatically generating the notification comprises automatically providing an indication to obtain a new reference glucose measurement for the user in response to determining a control parameter of the one or more control parameters for the operating mode cannot be calculated based on the glucose measurement data.

Paragraph 4. The method of paragraph 1, wherein determining the diagnosis time comprises:

- determining an expected start time for the subsequent instance of the operating mode based on the operational information; and

- determining the diagnosis time as a buffer time prior to the expected start time.

Paragraph 5. The method of paragraph 4, the operational information including start times for the respective one or more prior instances of the operating mode, wherein determining the expected start time comprises averaging the start times for the respective one or more prior instances.

Paragraph 6. The method of paragraph 5, further comprising determining the buffer time based at least in part on the operating mode of a plurality of operating modes supported by the infusion device.

Paragraph 7. The method of paragraph 1, further comprising determining an expected duration for the subsequent instance of the operating mode, wherein automatically determining the viability comprises determining the viability of the subsequent instance of the operating mode for the expected duration based at least in part on the status information.

Paragraph 8. The method of paragraph 7, the operational information including durations for the respective one or more prior instances of the operating mode, wherein determining the expected duration comprises averaging the durations for the respective one or more prior instances.

Paragraph 9. The method of paragraph 8, the operational information including start times for the respective one or more prior instances of the operating mode, wherein determining the diagnosis time comprises:

- determining an expected start time for the subsequent instance of the operating mode based on the start times for the respective one or more prior instances of the operating mode; and

- determining the diagnosis time as a buffer time before the expected start time.

Paragraph 10. The method of paragraph 7, the status information including glucose measurement data for the user, wherein determining the viability of the subsequent instance of the operating mode for the expected duration comprises determining whether one or more control parameters for the operating mode calculated based on the glucose measurement data will be valid for an entirety of the expected duration.

Paragraph 11. The method of paragraph 1, further comprising determining an expected duration for the subsequent instance of the operating mode based on the operational information, wherein:

automatically determining the viability comprises automatically performing a physical diagnostic check to determine a physical capability of the infusion device implementing the operating mode for the expected duration; and

automatically generating the notification comprises automatically generating the notification when the physical diagnostic check indicates an inability to implement the operating mode for the expected duration based on the status information.

Paragraph 12. The method of paragraph 1, further comprising determining an expected start time for the subsequent instance of the operating mode based on the operational information, wherein:

automatically determining the viability comprises automatically performing an algorithmic diagnostic check to determine an availability of the operating mode at the expected start time; and

automatically generating the notification comprises automatically generating the notification when the algorithmic diagnostic check indicates unavailability of the operating mode at the expected start time.

Paragraph 13. An infusion device comprising:

a user interface;

a data storage element to maintain status information pertaining to the infusion device;

a motor operable to deliver fluid to a body of a user, the fluid influencing a physiological condition of the user; and

a control system coupled to the motor, the data storage element, and the user interface to:

operate the motor in a first instance to deliver the fluid in accordance with an operating mode;

store operational information pertaining to the first instance of the operating mode in the data storage element;

determine a diagnosis time based at least in part on the operational information pertaining to the first instance of the operating mode;

at the diagnosis time, automatically determine viability of a subsequent instance of the operating mode based at least in part on the status information; and

automatically provide, via the user interface, a notification indicative of a recommended action based at least in part on the viability.

Paragraph 14. The infusion device of paragraph 13, wherein:

the status information includes measurement data pertaining to the physiological condition of the user; and

the control system determines the viability by determining whether one or more control parameters for the operating mode can be calculated in the future at an expected start time for the subsequent instance of the operating mode based on the measurement data.

Paragraph 15. The infusion device of paragraph 14, wherein the recommended action comprises obtaining a new reference measurement for the physiological condition of the user.

Paragraph 16. The infusion device of paragraph 13, wherein the control system determines the viability by determining a physical capability of the infusion device implementing the operating mode at an expected start time in the future for the subsequent instance of the operating mode for an expected duration of the subsequent instance of the operating mode.

Paragraph 17. The infusion device of paragraph 13, wherein the control system determines the viability by performing an algorithmic diagnostic check to determine availability of the operating mode at an expected start time in the future for the subsequent instance of the operating mode.

Paragraph 18. The infusion device of paragraph 17, the operating mode comprising a closed-loop operating mode for regulating the physiological condition of the user to a target value using one or more control parameters, wherein the algorithmic diagnostic

check comprises determining whether the one or more control parameters can be calculated at the expected start time.

Paragraph 19. An infusion system comprising:

a user interface;

a sensing arrangement to obtain measurements of a physiological condition in a body of a user; and

an infusion device coupled to the user interface and the sensing arrangement, the infusion device being operable to:

deliver fluid influencing the physiological condition of the user to the body of the user based at least in part on the measurements in accordance with an operating mode;

maintain status information pertaining to operation of the infusion device and operational information pertaining to one or more previous instances of the operating mode;

determine a diagnosis time in advance of an expected start time for a subsequent instance of the operating mode based at least in part on the operational information;

automatically determine, at the diagnosis time, viability of the subsequent instance of the operating mode based at least in part on the status information; and

automatically provide, via the user interface, a notification indicative of a recommended action based at least in part on the viability.

Paragraph 20. The infusion system of paragraph 19, the operating mode comprising a closed-loop operating mode for regulating the physiological condition of the user to a target value based on the measurements and one or more control parameters, wherein automatically determining the viability of the subsequent instance of the operating mode comprises determining whether the one or more control parameters can be calculated at the expected start time.

## CLAIMS

What is claimed is:

1. A method of operating an infusion device configured to deliver fluid to a user in accordance with a closed-loop operating mode to regulate a physiological condition of the user to a target value using one or more control parameters, the method comprising:

obtaining operational information pertaining to one or more prior instances of the closed-loop operating mode;

obtaining status information pertaining to the infusion device;

determining an expected start time for a subsequent instance of the closed-loop operating mode based on the operational information;

determining an expected duration for the subsequent instance of the closed-loop operating mode;

determining a diagnosis time prior to the expected start time for the subsequent instance of the closed-loop operating mode; and

at the diagnosis time prior to the expected start time:

automatically determining viability of entering the subsequent instance of the closed-loop operating mode at the expected start time for the expected duration based at least in part on the status information at the diagnosis time by performing an algorithmic diagnostic check to determine availability of the closed-loop operating mode at the expected start time in the future for the subsequent instance of the closed-loop operating mode, wherein the algorithmic diagnostic check comprises determining whether the one or more control parameters can be calculated at the expected start time; and

automatically generating a recommendation to the user of a corrective action if the subsequent instance of the closed-loop operating mode is determined as not being viable.

2. The method of claim 1, the status information including a physiological condition measurement data for the user, said physiological condition being influenced by the infused fluid, and wherein automatically determining the viability at the diagnosis time

comprises determining whether the one or more control parameters for the closed-loop operating mode can be calculated based on the physiological condition measurement data.

3. The method of claim 1, wherein said corrective action is to obtain a reference physiological condition measurement in response to determining a control parameter of the one or more control parameters for the closed-loop operating mode cannot be calculated due to a lack of sufficient physiological condition measurement data.

4. The method of any one of the preceding claims, wherein determining the diagnosis time comprises:

determining the diagnosis time as a buffer time prior to the expected start time.

5. The method of claim 4, the operational information including start times for the respective one or more prior instances of the closed-loop operating mode, wherein determining the expected start time comprises averaging the start times for the respective one or more prior instances.

6. The method of claim 4, wherein the infusion device is capable of operating in a plurality of different operating modes further comprising determining the said buffer time based on the closed-loop operating mode of the plurality of operating modes in which the infusion device is to be operated.

7. The method of claim 1, the operational information including durations for the respective one or more prior instances of the closed-loop operating mode, wherein determining the expected duration comprises averaging the durations for the respective one or more prior instances.

8. The method of claim 1, the status information including glucose measurement data for the user, wherein determining the viability of the subsequent instance of the closed-loop operating mode for the expected duration comprises determining whether the one or more control parameters for the closed-loop operating mode calculated based on the

physiological condition measurement data will be valid for an entirety of the expected duration.

9. The method of claim 1, further comprising determining an expected duration for the subsequent instance of the closed-loop operating mode based on the operational information, wherein:

automatically determining the viability comprises automatically performing a physical diagnostic check to determine a physical capability of the infusion device implementing the closed-loop operating mode for the expected duration; and

automatically generating a notification when the physical diagnostic check indicates an inability to implement the closed-loop operating mode for the expected duration based on the status information.

10. An infusion device capable of operating in a given operating mode comprising:

a user interface;

a data storage element to maintain status information pertaining to the infusion device and operational information pertaining to one or more prior instances of the closed-loop operating mode;

a motor operable to deliver fluid to a body of a user, the fluid influencing a physiological condition of the user; and

a control system coupled to the motor, the data storage element, and the user interface, and configured to perform the method of any one of the preceding claims.

11. An infusion system comprising:

a user interface;

a sensing arrangement to obtain measurements of a physiological condition in a body of a user; and

an infusion device coupled to the user interface and the sensing arrangement, the infusion device being operable to:

deliver fluid influencing the physiological condition of the user to the body of the user based at least in part on the measurements in accordance with a closed-loop operating mode to regulate the physiological condition of the user to a target value using one or more control parameters;

maintain status information pertaining to operation of the infusion device and operational information pertaining to one or more previous instances of the closed-loop operating mode;

determine an expected start time for a subsequent instance of the closed-loop operating mode based on the operational information;

determine an expected duration for the subsequent instance of the closed-loop operating mode;

determine a diagnosis time in advance of the expected start time for the subsequent instance of the closed-loop operating mode based at least in part on the operational information; and

at the diagnosis time prior to the expected start time:

automatically determine viability of the subsequent instance of the closed-loop operating mode based at least in part on the status information by performing an algorithmic diagnostic check to determine availability of the closed-loop operating mode at the expected start time in the future for the subsequent instance of the closed-loop operating mode, wherein the algorithmic diagnostic check comprises determining whether the one or more control parameters can be calculated at the expected start time; and

automatically provide, via the user interface, a recommendation to the user of a corrective action if the subsequent instance of the closed-loop operating mode is determined as not being viable.

12. The method of any one of claims 1 to 9 or the device of claim 10, wherein the fluid is insulin.

13. The method of any one of claims 2, 3 or 8 or any claim dependant thereon, wherein the fluid is insulin and the physiological condition is blood glucose concentration.

14. The device of claim 10 or the system of claim 11, wherein the fluid is insulin and the physiological condition is blood glucose concentration.

15. An infusion device for a medicinal fluid, the device including:  
a user interface ;  
a motor operable to deliver the fluid in response to commands;

a sensor configured to sense a physiological condition influenced by the medicinal fluid;

a pump control module coupled to the user interface, the motor, and the sensor, and including:

a command generator comprising;

a first algorithm which when executed causes the command generator to issue commands to the motor to deliver the fluid according to a predetermined schedule; and

a second algorithm which when executed causes the command generator to issue commands to the motor to deliver fluid to implement a closed-loop control to bring the measured physiological condition to a target value, said second algorithm having gain coefficients;

the command generator further being switchable to execute either the first or the second algorithm;

a diagnostic unit connected to the command generator and configured to receive an expected start time for a future switching of the command generator from the first algorithm to the second algorithm and starting a buffer time period before the expected start time checking the viability of operation of the closed-loop control of the command generator for an expected duration after the future switching time by performing an algorithmic diagnostic check to determine that the second algorithm gain coefficients can be calculated at the expected start time;

the diagnostic unit also being configured to provide, to the user interface, a recommendation of a corrective action if the closed-loop control is determined as not being viable.

16. The infusion system of claim 15 wherein the infusion device further includes a memory connected to record the start times of the day of each period during which the second algorithm is executed and said expected start time is set to an average of said start times.

17. The infusion system of claim 15 or 16 wherein the infusion device further includes a memory connected to record the duration times of each period during which the second algorithm is executed and said diagnostic unit reports a lack of viability, if battery

status, medicinal fluid reserve, or currency of sensor calibration would not last the average of said duration times starting at said expected future switching time.

18. The infusion system of any one of claims 15 to 17 wherein the medicinal fluid is insulin and the physiological condition is blood glucose concentration.

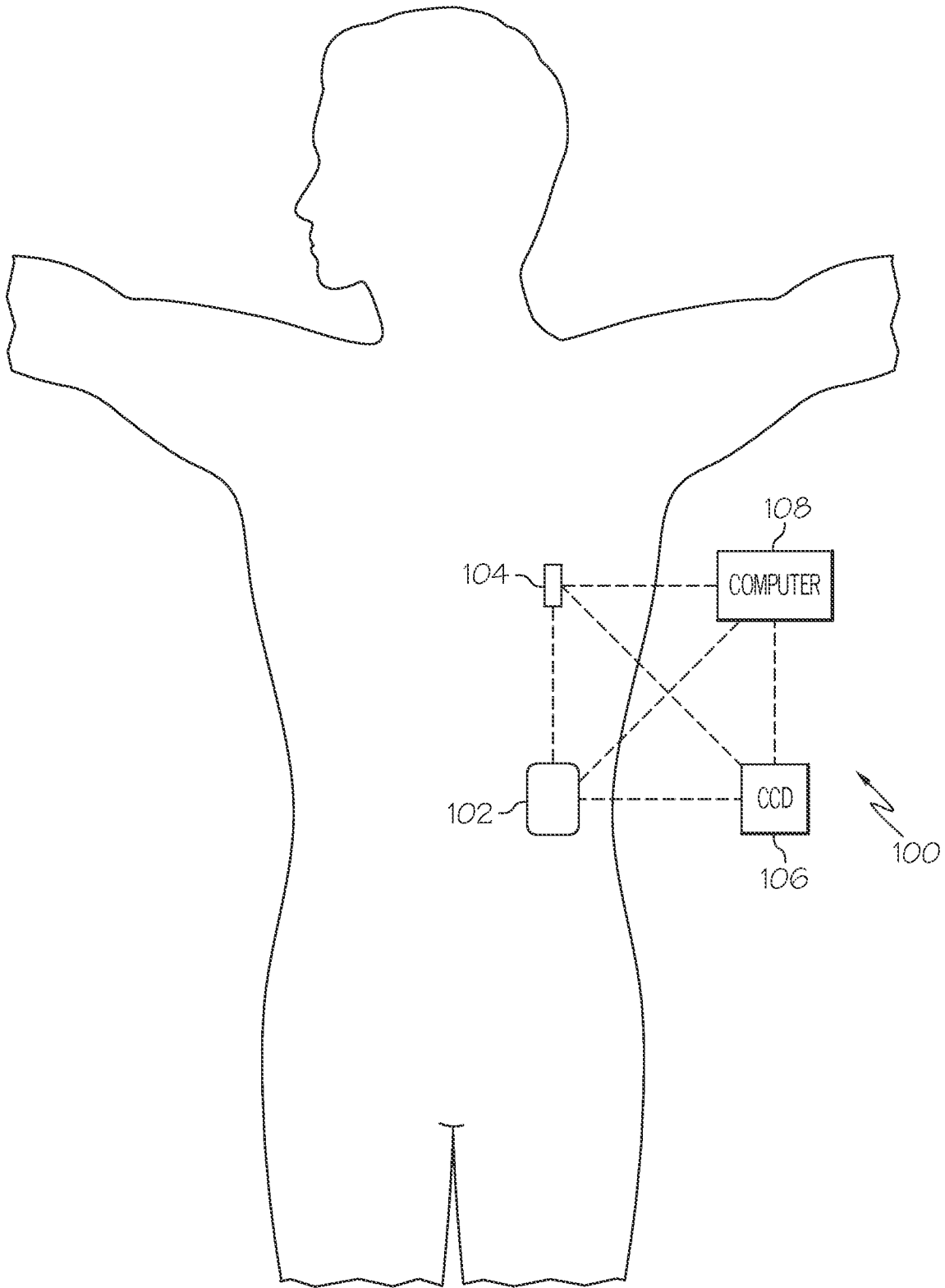

FIG. 1

2 / 8

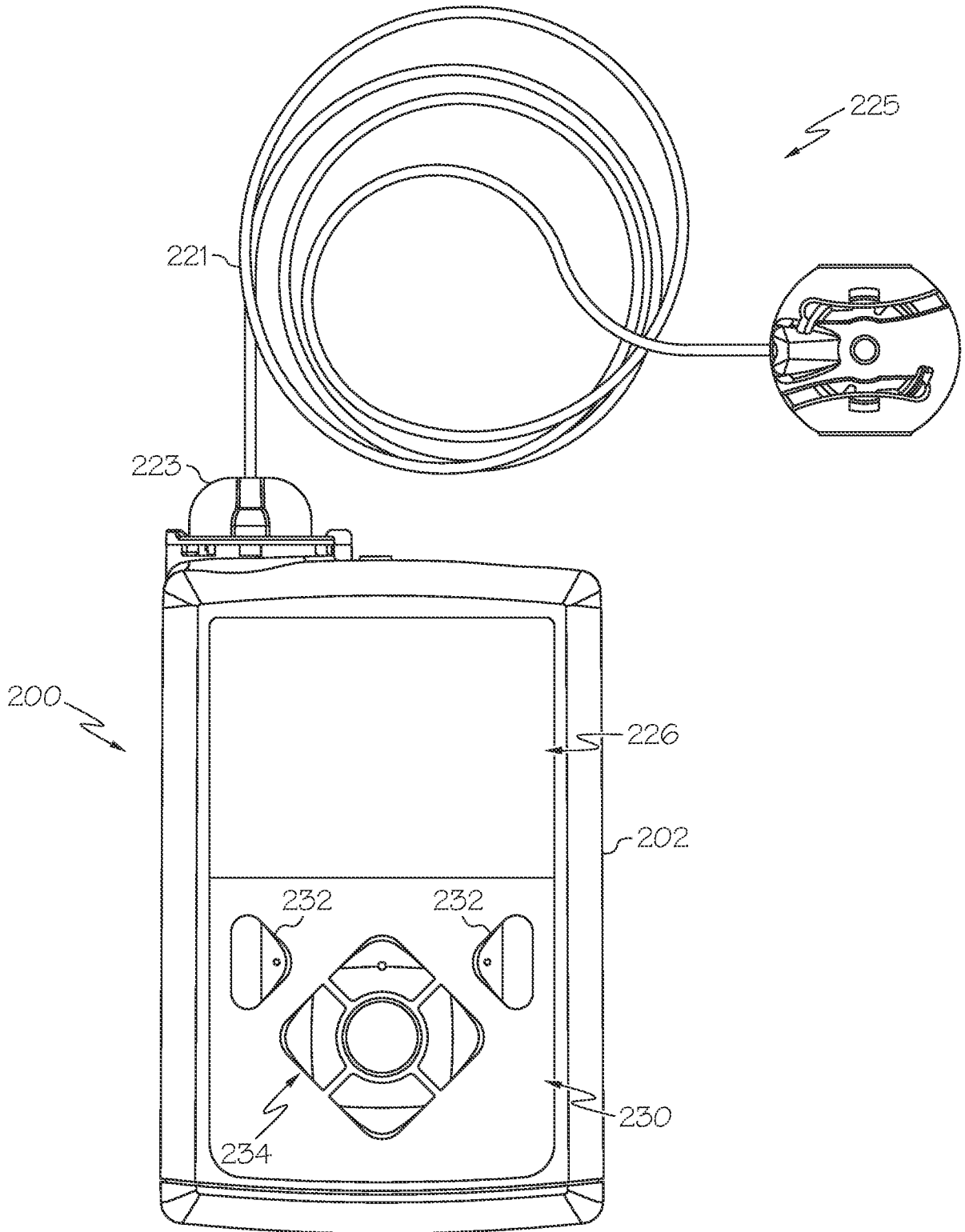

FIG. 2

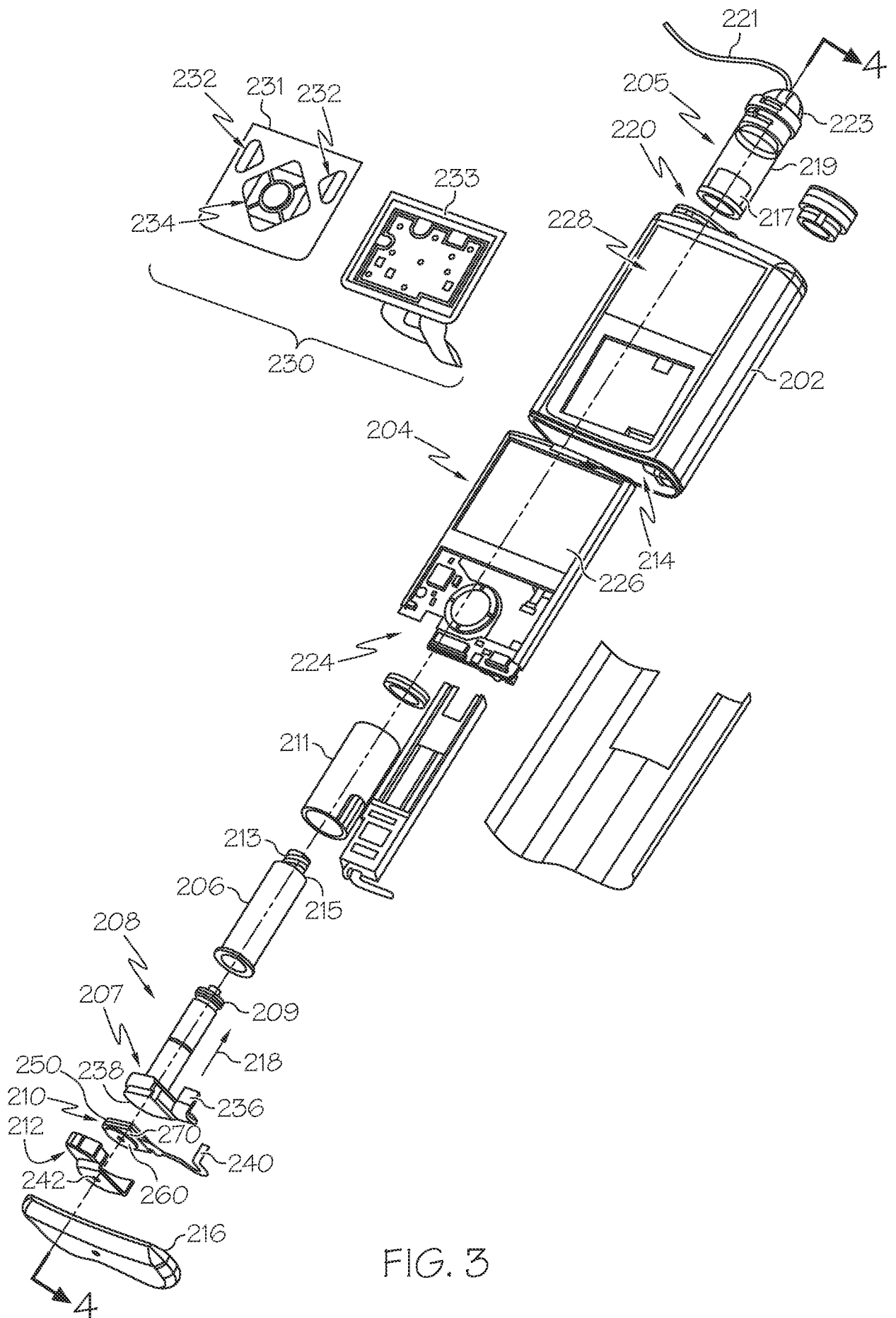

FIG. 3

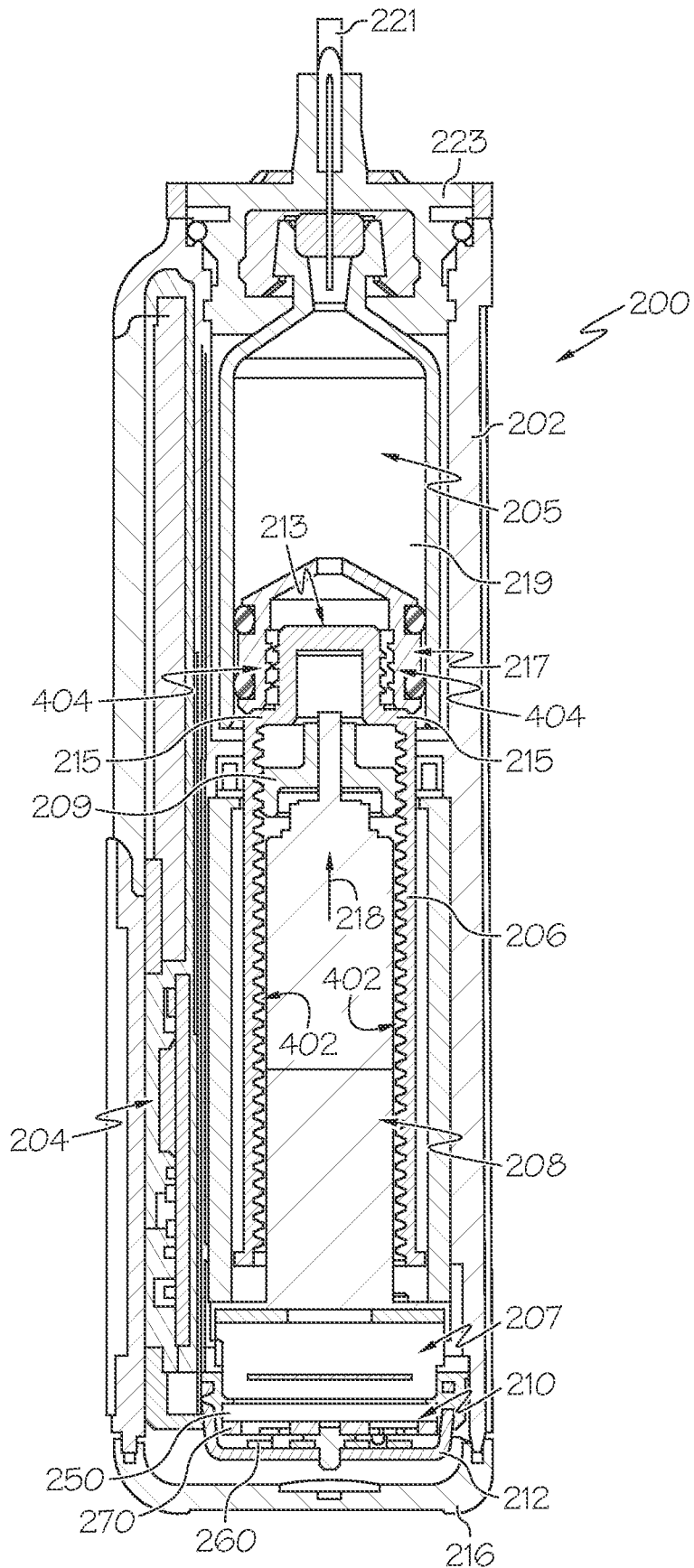

FIG. 4

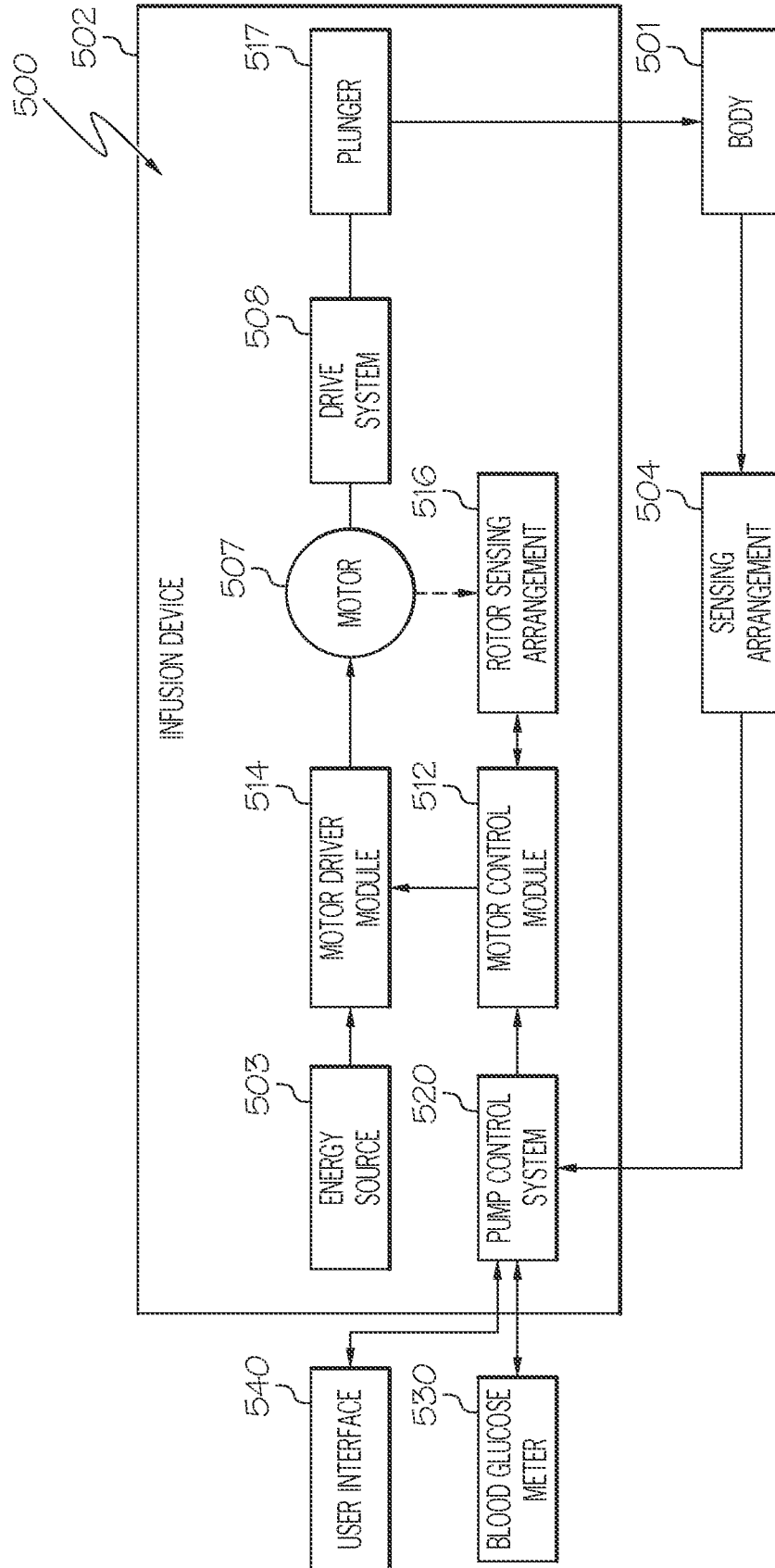

FIG. 5

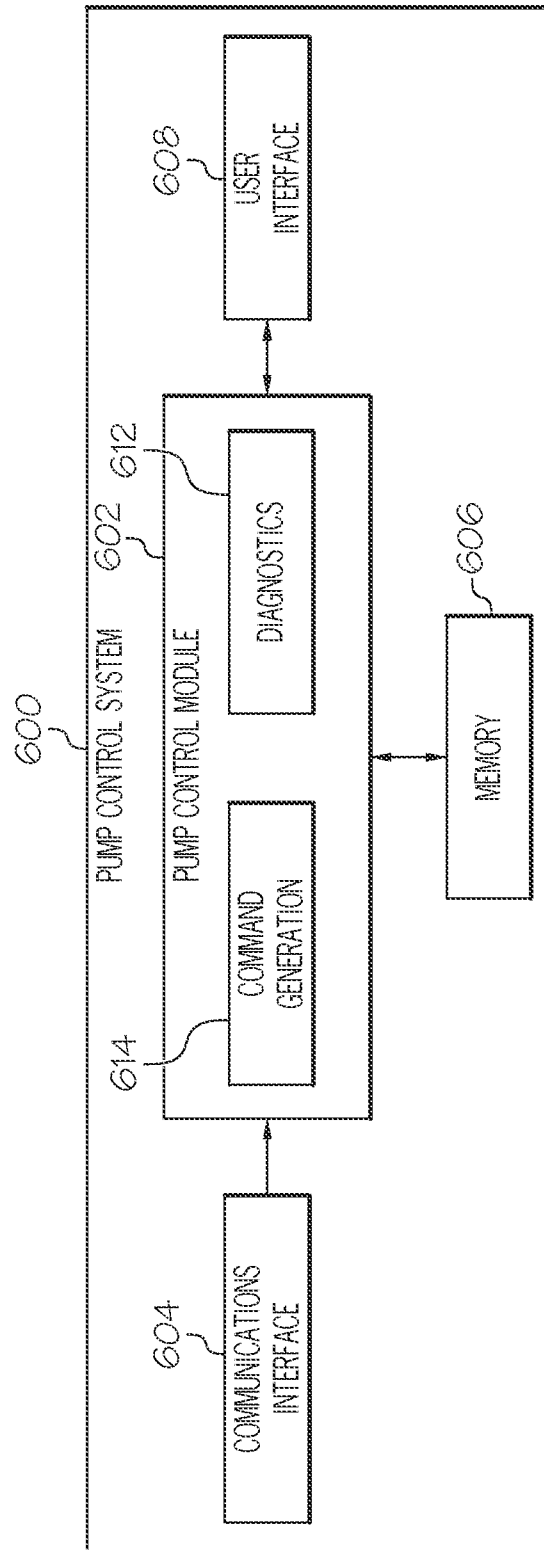

FIG. 6

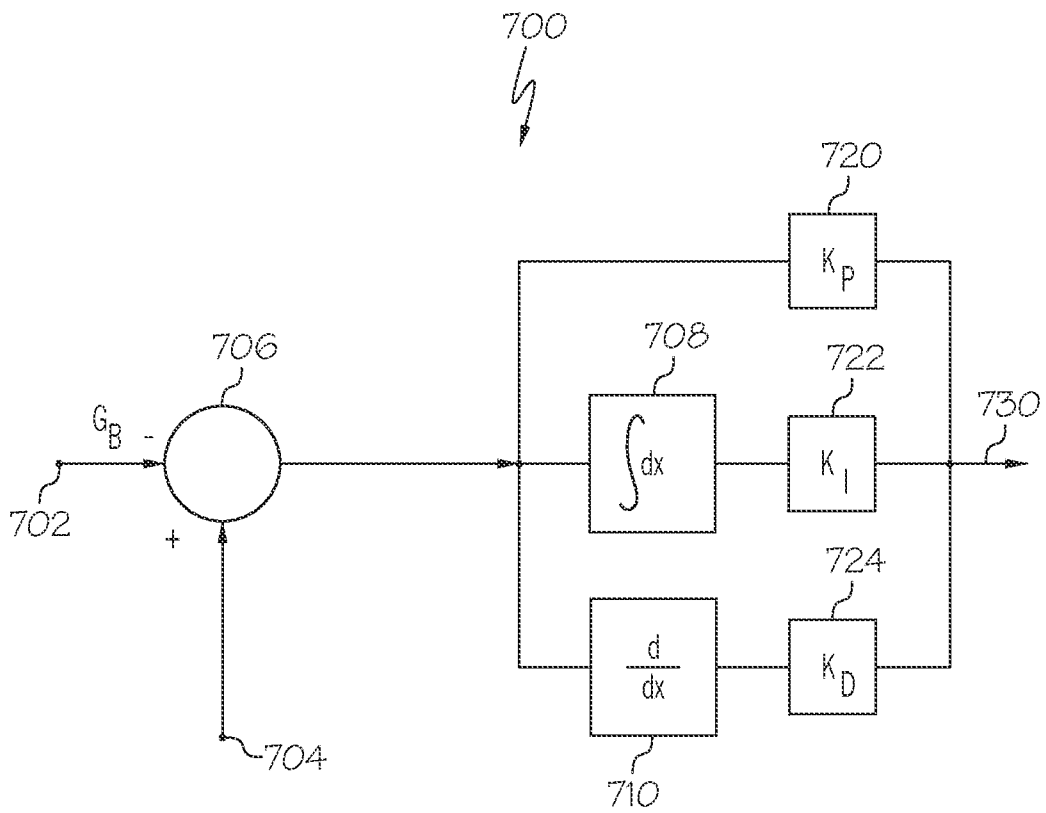

FIG. 7

8 / 8

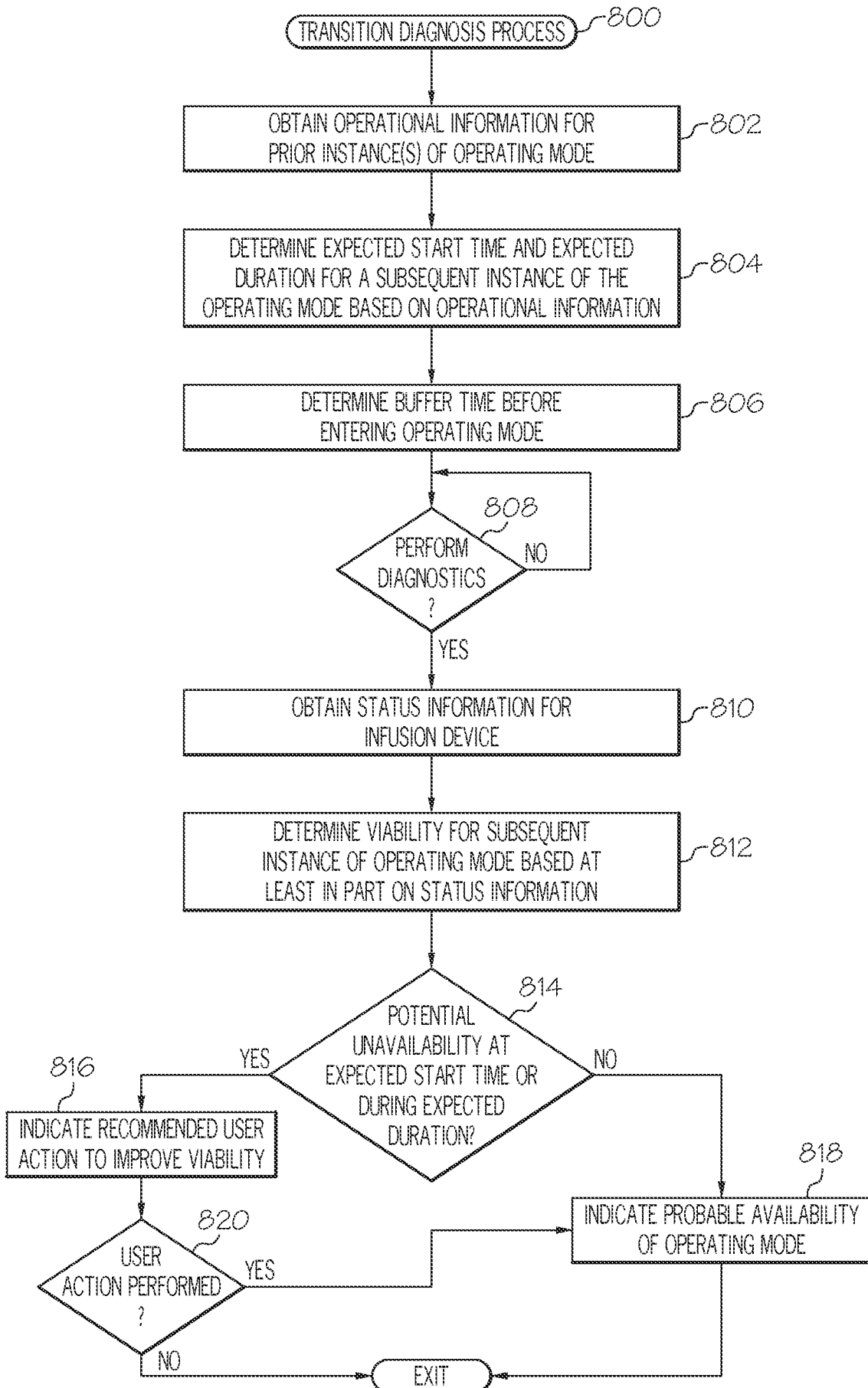

FIG. 8