

(19) World Intellectual Property Organization
International Bureau



(43) International Publication Date
23 December 2009 (23.12.2009)

(10) International Publication Number
WO 2009/155287 A1

- (51) International Patent Classification:
A61B 17/04 (2006.01) A61B 1/00 (2006.01)
A61B 1/04 (2006.01)
- (21) International Application Number:
PCT/US2009/047508
- (22) International Filing Date:
16 June 2009 (16.06.2009)
- (25) Filing Language: English
- (26) Publication Language: English
- (30) Priority Data:
61/073,340 17 June 2008 (17.06.2008) US
61/162,249 20 March 2009 (20.03.2009) US
- (71) Applicant (for all designated States except US): **APOLLO ENDOSURGERY, INC.** [US/US]; 7000 Bee Caves Road, Suite 250, Austin, TX 78746 (US).
- (72) Inventors; and
(75) Inventors/Applicants (for US only): **GILKEY, J., Landon** [US/US]; 5608 Apple Orchard Lane, Austin, TX 78744 (US). **JONES, Donald, K.** [US/US]; 705 N. Canyonwood Drive, Dripping Springs, TX 78620 (US). **KRATSCH, Peter, K.** [US/US]; 1219 Pine Portage Loop, Leander, TX 78641 (US). **NAGLREITER, Brett,**
- E. [US/US]; 201 Lavaca Street, Apt. 341, Austin, TX 78701 (US).
- (74) Agent: **GORDON, David, P.**; Gordon & Jacobson, P.C., 60 Long Ridge Road, Suite 407, Stamford, CT 06902 (US).
- (81) Designated States (unless otherwise indicated, for every kind of national protection available): AE, AG, AL, AM, AO, AT, AU, AZ, BA, BB, BG, BH, BR, BW, BY, BZ, CA, CH, CL, CN, CO, CR, CU, CZ, DE, DK, DM, DO, DZ, EC, EE, EG, ES, FI, GB, GD, GE, GH, GM, GT, HN, HR, HU, ID, IL, IN, IS, JP, KE, KG, KM, KN, KP, KR, KZ, LA, LC, LK, LR, LS, LT, LU, LY, MA, MD, ME, MG, MK, MN, MW, MX, MY, MZ, NA, NG, NI, NO, NZ, OM, PE, PG, PH, PL, PT, RO, RS, RU, SC, SD, SE, SG, SK, SL, SM, ST, SV, SY, TJ, TM, TN, TR, TT, TZ, UA, UG, US, UZ, VC, VN, ZA, ZM, ZW.
- (84) Designated States (unless otherwise indicated, for every kind of regional protection available): ARIPO (BW, GH, GM, KE, LS, MW, MZ, NA, SD, SL, SZ, TZ, UG, ZM, ZW), Eurasian (AM, AZ, BY, KG, KZ, MD, RU, TJ, TM), European (AT, BE, BG, CH, CY, CZ, DE, DK, EE, ES, FI, FR, GB, GR, HR, HU, IE, IS, IT, LT, LU, LV, MC, MK, MT, NL, NO, PL, PT, RO, SE, SI, SK, TR),

[Continued on next page]

(54) Title: ENDOSCOPIC SUTURING SYSTEM

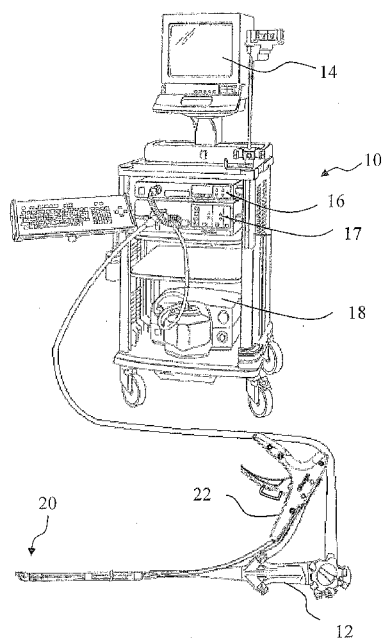

FIG. 1

(57) Abstract: An endoscopic suturing system and method are disclosed as are devices for use with the system and method such as a suture dispenser, a cinch device, and a tissue grasper. In one embodiment the suturing system includes a cap assembly arranged at the distal end portion of an endoscope or guide member, with the cap assembly including a rotatable needle holder. The needle holder is actuated through a transmission element extending outside the endoscope or guide member. A needle capture device may be inserted through a channel of the endoscope or guide member in order to capture a needle held in the needle holder when the needle holder is rotated so that the needle punctures tissue.

WO 2009/155287 A1

OAPI (BF, BJ, CF, CG, CI, CM, GA, GN, GQ, GW, ML,
MR, NE, SN, TD, TG).

— *before the expiration of the time limit for amending the
claims and to be republished in the event of receipt of
amendments (Rule 48.2(h))*

Published:

— *with international search report (Art. 21(3))*

ENDOSCOPIC SUTURING SYSTEM

CLAIM OF PRIORITY

This application claims priority from provisional patent application U.S. 61/073,340 file June 17, 2008 and from provisional patent application U.S. 61/162,249 filed March 20, 2009, both of which are hereby incorporated by reference herein in their entireties.

BACKGROUND OF THE INVENTION

1. Field of the Invention

[001] The present invention relates to a treatment device which can be inserted into a body through a natural orifice with an endoscope or other steerable guide member. The present invention may be used to perform suturing on the tissue of a mammal, whether human or not, and whether or not alive, but is not limited thereto.

2. Description of the Related Art

[002] U.S. Pat No. 7,344,545 (Olympus Corporation) discloses an endoscopic suturing system having many embodiments to perform a surgical operation. This suturing system generally comprises an assembly having first and second arms which are actuatable by a push rod to rotatably approach each other while one arm grasps tissue and the second arm drives a curved needle through the tissue. The system also includes a needle recovery member requiring a rigid alignment with the curved needle arm. While this system affords the ability to grasp thick tissue, the tissue grasping arm and the arrangement of the needle recovery member provides bulk to the system making it difficult to use in endoscopic procedures.

SUMMARY OF THE INVENTION

[003] The present invention provides an endoscopic treatment device having a structure enabling a small profile for delivery while providing both a large opening and closing angle and producing a large needle force for piercing tissue to perform a surgical operation such as tissue approximation and suturing within the body.

[004] In accordance with an aspect of the present invention there is provided an endoscopic treatment device which is used to perform treatment in a body while being operated outside the body. The treatment device comprises a flexible member coupled to a proximal handle assembly for operation outside of the body and a distal cap assembly where the cap assembly is adapted to engage the distal end of an endoscope. The flexible member is connected to a link mechanism

and is actuated to cause a needle assembly having a needle holder arm and needle which are coupled to the cap assembly to move in a direction to puncture tissue and a direction to be removed from tissue.

[005] According to another aspect of the present invention there is provided an endoscopic treatment system for use with an endoscope having a cap assembly adapted to be positioned at the distal end of an endoscope where the cap assembly has at least one mounting bracket which is fixedly attached. A transmission member with a flexible structure has a distal end portion that is inserted into a body and is capable of being operated outside the body by a proximal portion coupled to a handle assembly. A push rod is coupled to the distal end portion of the transmission member. A connecting member having a needle holder arm is coupled to the push rod and pivotally coupled to the mounting bracket. A removable needle is connected to the needle holder arm and is adapted to pierce tissue. When the push rod is actuated by the transmission member, the connecting member moves the needle holder arm in a direction to pierce tissue or in a direction to remove it from tissue. An elongate needle capture device is positioned within the instrument channel of the endoscope and has a distal end adapted to receive and grasp the needle and a proximal end coupled to a handle assembly.

[006] In accordance with another aspect of the present invention there is provided a removable needle assembly having a needle tip member and a needle base member. The needle tip member has a sharpened end which is adapted to pierce tissue and a hollow end to receive the needle base member. The needle tip member also includes an aperture which may take the form of a longitudinal slot through the wall adjacent the hollow end which is adapted to allow suture to extend there from. The needle base member has a first end which is adapted to engage the hollow end of the needle tip member and a second end which is adapted to removably engage a needle holder arm. The needle base member further includes a stop member which when coupled with the needle holder arm limits the depth to which the needle base is inserted into the needle holder arm. The coupling engagement of needle tip member and the first end of the needle base member are adapted to secure a length of suture material to the needle assembly and allow it to extend through the aperture adjacent the hollow end of the needle tip member.

[007] In accordance with still another aspect of the present invention there is provided a needle clip assembly having first and second ends where a needle tip adapted for piercing tissue is positioned at the first end and a tissue stop member is positioned at the second end. The needle clip assembly has a constrained first configuration and an unconstrained second configuration where the needle clip assembly is resiliently biased to move from the first configuration to the second configuration. The constrained first configuration may take the form of a generally

straightened elongate member. The unconstrained second configuration may take the form of a loop, helix or substantially closed loop form.

[008] In accordance with yet another aspect of the present invention there is provided an endoscopic treatment system for use with an endoscope having a cap assembly adapted to be positioned at the distal end of an endoscope where the cap assembly has two pair of fixedly attached mounting brackets. A transmission member with a flexible structure has a distal end portion that is inserted into a body and is capable of being operated outside the body. A push rod is coupled to the distal end portion of the transmission member. A connecting member having a needle holder arm is coupled to the push rod and pivotally coupled to the outer pair of mounting brackets. A link member having two ends is pivotally coupled to the inner pair of mounting brackets at one end and pivotally coupled to the needle holder arm at the other end. A removable needle is connected to the needle holder arm and is adapted to pierce tissue. When the push rod is actuated by the transmission member, the connecting member moves the needle holder arm in a direction to pierce tissue or a direction to remove it from tissue. An elongate needle capture device is positioned within the instrument channel of the endoscope having a proximal handle and a distal end adapted to receive and grasp the needle.

[009] In accordance with yet another aspect of the present invention there is provided a combination handle assembly adapted to operate the movement of the transmission member thereby opening and closing the needle arm and adapted to operate the needle capture device to thereby grasp and release the needle. The handle assembly includes a handle main body coupled to an endoscope channel coupling which is adapted to engage the instrument channel of an endoscope. An elongate needle capture device includes a proximal housing which is removably coupled to the handle main body and a distal end is which positioned through the endoscope channel coupling into the instrument channel of an end. An actuatable trigger lever is coupled to handle main body and operates the transmission member to axially advance or retract the transmission member.

[0010] In accordance with another aspect of the present invention there is provided an endoscopic treatment system that further includes a tissue grasping member. The tissue grasping member takes the form of an elongate member having proximal and distal ends and is positioned within a channel of an endoscope. The distal end of the tissue grasping member may take the form of a helix or tapered spiral in which rotation of the helix when at a desired site adjacent tissue, causes the helix to substantially engage the tissue and allow the tissue to be retracted.

[0011] In accordance with still another aspect of the present invention there is provided an endoscopic treatment system that further includes a tissue grasping member. The tissue grasping

member takes the form of an elongate member having proximal and distal ends and is positioned with a channel of an endoscope. The distal end of the tissue grasping member may take the form of a pair of jaws such that when at a desired site adjacent tissue, operation of the jaws causes the jaws to substantially engage the tissue and allow the tissue to be retracted.

[0012] In accordance with another aspect of the present invention there is provided an endoscopic treatment device which is used to perform treatment in a body while being operated outside the body. The treatment device comprises a flexible member coupled to a proximal handle assembly for operation outside of the body and a distal cap assembly where the cap assembly is adapted to engage the distal end of an endoscope. The cap assembly includes an elongate channel lock member having one end which is fixedly attached to the cap assembly and extends through the channel of an endoscope and is removably secured to the proximal end of the endoscope channel. The channel lock member may take the form of a small diameter flexible wire assembly or wire braid assembly.

[0013] In accordance with yet another aspect of the present invention there is provided an endoscopic suturing system for use with an endoscope having a cap assembly adapted to be positioned at the distal end of an endoscope where the cap assembly defines mounting locations. A transmission member with a flexible structure has a distal end portion that is inserted into a body and is capable of being operated outside the body. A push member is optionally coupled to the distal end portion of the transmission member. A link member having a geared portion is coupled to the push member or the transmission member and pivotally coupled at a first mounting location. A connecting member having a geared portion and a needle holding arm at one end is pivotally coupled at a second mounting location such that the geared portions of the link member and the connecting member intermesh.

[0014] In accordance with another aspect of the present invention there is provided an endoscopic suturing system for use with an endoscope having a cap assembly adapted to be positioned at the distal end of the endoscope where the cap assembly includes an elongate needle guard. The needle guard generally extends from a base of the cap in a direction distal to the end of the endoscope. Preferably the needle guard extends in a distal direction parallel to the axis of the endoscope. The needle guard is adapted to prevent tissue from inadvertently contacting the needle tip while the needle tip is in an open position and the tissue is being positioned for suturing.

[0015] In accordance with another aspect of the present invention there is provided an endoscopic suturing system for use with an endoscope having a cap assembly adapted to be positioned at the distal end of the endoscope where the cap assembly includes an elongate

channel guard. The channel guard generally extends from a base of the cap in a direction distal to the end of the endoscope and is coaxial with the endoscope channel which used by the needle capture device. The channel guard is adapted to aid in suturing by positioning tissue a sufficient distance away from the end of the endoscope channel allowing for better visualization and providing a surface to support the tissue during the suturing operation. Preferably, the distal end of the channel guard is inclined to provide a plane which is generally perpendicular to the needle tip as the needle tip intersects the plane along the needle suturing path. Preferably, the minimum length that the channel guard extends from the cap is related to the field of view from the endoscope such that minimum length allows sufficient tissue to be visualized when the tissue is placed in a position for suturing.

[0016] In accordance with another aspect of the present invention there is provided an endoscopic treatment device which is used to perform treatment in a body while being operated outside the body. The treatment device comprises a flexible member coupled to a proximal handle assembly for operation outside of the body and a distal cap assembly where the cap assembly is adapted to engage the distal end of an endoscope. The cap assembly includes an elongate channel lock member having one end which is removably secured to the cap assembly and extends through the channel of an endoscope and is removably secured to the proximal end of the endoscope channel by a tensioning assembly. The channel lock member may take the form of a small diameter flexible wire assembly or wire braid assembly. Preferably, the channel lock member includes retaining members fixedly secured to each end. The tensioning assembly includes a bayonet lock fitting adapted to engage a bayonet prong on the endoscope, a housing member, a rotatable wheel member having a tab member and a tensioner member. The proximal end of the channel lock member is secured to the tab member of the rotatable wheel such that rotation of the wheel applies a preset tension to the channel lock member. The housing member of the tensioning assembly in conjunction with the tensioner member, preferably formed of a spring, maintains the tension on the channel lock member by resisting compression during normal bending operation of the endoscope.

[0017] According to another aspect of the endoscopic treatment system of the present invention there is provided a cinch system including a cinch delivery device and a cinch device. The cinch delivery device takes the form of an elongate tubular member having proximal end coupled to a handle assembly and a distal end. The distal end of the cinch delivery device is removably coupled to the cinch device. The cinch device has a housing that incorporates a suture capture hook at its distal end for capturing suture that has been placed through tissue. A cinch plug is positioned within the cinch housing and is movable from a first suture non-retaining position to

a second suture retaining position for securing suture in a fixed position by operating the handle assembly. Once suture has been secured by the cinch plug in the cinch housing the handle assembly may be operated to uncouple the cinch device from the cinch delivery tool.

[0018] According to still another aspect of the present invention, there is provided a suturing method using an endoscopic suturing system. This method comprises the steps of:

(1) inserting a guide tube and/or endoscope into a body with a suturing device coupled to the endoscope and or guide tube;

(2) opening a needle arm of the suturing device having a removable needle;

(3) pushing the needle against tissue at a desired suture site;

(4) closing the needle arm of the suturing device;

(5) piercing the tissue with the needle;

(6) recovering the needle by using a needle capture device;

(7) removing the needle from the tissue;

(8) opening the needle arm to remove it from tissue;

(9) closing the needle arm; and

(10) removing the suturing device from the body.

[0019] According to yet another aspect of the present invention, there is provided a suturing method using an endoscopic suturing system including a tissue grasper. This method comprises the steps of:

(1) inserting a guide tube into a body;

(2) inserting a suturing device coupled to an endoscope into the guide tube and into the body;

(3) opening a needle arm of the suturing device having a removable needle;

(4) engaging a tissue adjacent a desired suture site using a tissue grasper;

(5) pushing the needle against tissue at a desired suture site;

(6) closing the needle arm of the suturing device;

(7) piercing the tissue with the needle;

(8) recovering the needle by using a needle capture device;

(9) removing the needle from the tissue;

(10) opening the needle arm to remove it from tissue;

(11) releasing the tissue from the tissue grasper;

(12) closing the needle arm; and

(13) removing the suturing device from the body.

[0020] According to another aspect of the present invention, there is provided a suturing method of performing a running stitch using an endoscopic suturing system. This method comprises the steps of:

- (1) inserting a guide tube into a body;
- (2) inserting a suturing device coupled to the endoscope into the guide tube and inserting the suturing device into the body;
- (3) opening a needle arm of the suturing device having a removable needle;
- (4) pushing the needle against tissue at a desired suture site;
- (5) closing the needle arm of the suturing device;
- (6) piercing the tissue with the needle;
- (7) recovering the needle by using a needle capture device;
- (8) removing the needle from the tissue;
- (9) opening the needle arm to remove it from tissue;
- (10) closing the needle arm;
- (11) inserting the needle into the needle arm endoscopically using the needle capture device;
- (12) performing steps (3) through (11) as needed.

[0021] According to still yet another aspect of the present invention there is provided a method of securing tissue using an endoscopic suturing system including a resilient pre-biased needle clip and a tissue grasper. This method comprises the steps of:

- (1) inserting a guide tube into a body;
- (2) inserting a suturing device coupled to the endoscope into the guide tube and inserting the suturing device into the body;
- (3) opening a needle holding arm of the suturing device having a removable needle clip;
- (4) engaging a tissue adjacent a desired suture site using a tissue grasper
- (5) pushing the needle clip against tissue at a desired suture site;
- (6) closing the needle holding arm of the suturing device;
- (7) piercing the tissue with the needle clip;
- (8) grasping the needle clip tip using a needle capture device;
- (9) opening the needle holding arm to remove it from tissue;
- (10) releasing the needle clip from the needle capture device
- (11) releasing the tissue from the tissue grasper;
- (12) closing the needle holding arm; and
- (13) removing the suturing device from the body.

[0022] Advantages of the invention will be set forth in the description which follows, and in part will be obvious from the description, or may be learned by practice of the invention. Advantages of the invention may be realized and obtained by means of the instrumentalities and combinations particularly pointed out hereinafter.

BRIEF DESCRIPTION OF THE DRAWINGS

[0023] The accompanying drawings, which are incorporated in and constitute a part of the specification, illustrate embodiments of the invention, and together with the general description given above and the detailed description of the embodiments given below, serve to explain the principles of the invention.

[0024] FIG. 1 is an illustrative view showing an endoscopic suturing system with endoscope system according to a first embodiment of the present invention;

[0025] FIG. 2 is an enlarged view of the proximal portion of an endoscope and an endoscopic suturing system shown in FIG.1;

[0026] FIG. 3 is a perspective enlarged view of the distal end of an endoscopic suturing system according to an embodiment of the present invention where the actuating arm of the suturing device is closed;

[0027] FIG. 4 is a perspective enlarged view of the distal end of an endoscopic suturing system according to an embodiment of the present invention where the actuating arm of the suturing device is open;

[0028] FIG. 5 is another perspective enlarged view of the distal end of an endoscopic suturing system according to an embodiment of the present invention where the actuating arm of the suturing device is open;

[0029] FIG. 6 is a perspective enlarged view of the cap assembly of an endoscopic suturing system according to an embodiment of the present invention where the actuating arm of the suturing device is closed;

[0030] FIG. 7 is an illustrative view of a needle assembly for use with an endoscopic suturing device according to an embodiment of the present invention;

[0031] FIG. 8 is an exploded view of a needle assembly of FIG. 7;

[0032] FIG. 9 is an illustrative view of a needle assembly for use with an endoscopic suturing device according to another embodiment of the present invention.

[0033] FIG. 10 is a view of an endoscopic clip for use with an endoscopic suturing system according to an embodiment of the present invention;

[0034] FIG. 11 is a view of the preferentially biased resilient endoscopic clip of FIG. 10 when unconstrained.

[0035] FIG. 12 is a view of an endoscopic clip for use with an endoscopic suturing system according to another embodiment of the present invention;

[0036] FIG. 13 is a view of the preferentially biased resilient endoscopic clip of FIG. 12 when unconstrained;

[0037] FIG. 13A is a view of the preferentially biased resilient modified endoscopic clip of FIG. 13 when unconstrained and having a coil that extends over the sharp tip;

[0038] FIG. 14 is a view of the helical tissue grasper;

[0039] FIG. 15 is an enlarged view of the distal end of the helical tissue grasper;

[0040] FIG. 16 is a top view of a cinch device and cinch delivery device;

[0041] FIG. 17 is a side view of a cinch device and cinch delivery device;

[0042] FIG. 18 is an enlarged exploded view of the distal end of the cinch and cinch delivery device;

[0043] FIG. 19 is an enlarged view of the cinch device in an open configuration;

[0044] FIG. 20 is an enlarged view of the cinch device in a closed configuration;

[0045] FIG. 21 is a sectional view of an endoscopic guide tube;

[0046] FIG. 22 is a partial sectional view of an endoscopic suturing system disposed within the lumen of an endoscopic guide tube;

[0047] FIG. 23 is a partial sectional view of an endoscopic suturing system extending from the distal end of an endoscopic guide tube;

[0048] FIG. 24 through FIG. 34 illustrate steps in a surgical suturing procedure using an endoscopic suturing system according to an embodiment of the present invention wherein FIG. 24 is a view of a step in which a an endoscopic suturing device is positioned adjacent a wound at a desired treatment location;

[0049] FIG. 25 is a view of a step in which a tissue grasper is extended adjacent a wound at a desired treatment location;

[0050] FIG. 26 is a view of a step in which a tissue grasper engages tissue and is slightly retracted to bring tissue closer to the endoscope;

[0051] FIG. 27 is a view of an alternative step in which a tissue grasper engages tissue and is substantially retracted to bring tissue in contact with the endoscope;

[0052] FIG. 28 is a view of a step in which the needle pierces tissue;

[0053] FIG. 29 is a view of a step in which the needle holder arm is removed from the tissue depositing a suture through the tissue;

[0054] FIG. 30 is a view of a step in which the tissue grasper disengages the tissue;

[0055] FIG. 31 is a view of a step in which the needle is reloaded into the needle holder arm;

[0056] FIG. 32 is a view of a step in which a cinch device captures suture;

[0057] FIG. 33 is a view of a step in which the suture is tightened using the cinch device to thereby close the wound;

[0058] FIG. 34 is a view of a cinch device released from the cinch delivery device;

[0059] FIG. 35 through FIG. 38 illustrate steps in a surgical suturing procedure using an endoscopic suturing system according to another embodiment of the present invention wherein FIG. 35 is a view of a step in which an endoscopic suturing device has delivered a needle through tissue at a desired treatment location;

[0060] FIG. 36 is a view of a step in which a cinch device captures suture;

[0061] FIG. 37 is a view of a step in which the suture is tightened using the cinch device to thereby close the wound;

[0062] FIG. 38 is a view of a cinch device released from the cinch delivery device;

[0063] FIG. 39 through FIG. 42 illustrate steps in a surgical suturing procedure using an endoscopic suturing system according to yet another embodiment of the present invention wherein FIG. 39 is a view of a step in which an endoscopic suturing device having a needle clip is positioned at a desired treatment location;

[0064] FIG. 40 is a view of a step in which the needle clip pierces tissue;

[0065] FIG. 41 is a view of a step in which the needle holder arm is removed from the tissue depositing the needle clip through the tissue;

[0066] FIG. 42 is a view of a step in which the tissue grasper disengages the tissue and the needle clip close the wound;

[0067] FIG. 43 is an illustrative view showing an endoscopic suturing system with a channel lock member according to another embodiment of the present invention;

[0068] FIG. 44 is a perspective enlarged view of the cap assembly of an endoscopic suturing system according to an embodiment of the present invention where the actuating arm of the suturing device is closed;

[0069] FIG. 45 is a perspective enlarged view of the cap assembly of an endoscopic suturing system according to an embodiment of the present invention where the actuating arm of the suturing device is open;

[0070] FIG. 46 is a perspective enlarged exploded view of the cap assembly of an endoscopic suturing system according to an embodiment of the present invention;

[0071] FIG. 47 is another perspective enlarged view of the cap assembly of an endoscopic suturing system according to an embodiment of the present invention where the actuating arm of the suturing device is closed;

[0072] FIG. 48 is yet another perspective enlarged view of the cap assembly of an endoscopic suturing system according to an embodiment of the present invention where the actuating arm of the suturing device is closed;

[0073] FIG. 49 is still another perspective enlarged view of the cap assembly of an endoscopic suturing system according to an embodiment of the present invention;

[0074] FIG. 50 is still yet another perspective enlarged view of the cap assembly of an endoscopic suturing system according to an embodiment of the present invention;

[0075] FIG. 51 is perspective enlarged view of the channel lock tensioner assembly in a first configuration according to an embodiment of the present invention;

[0076] FIG. 52 is perspective enlarged view of the channel lock tensioner assembly in a second configuration according to an embodiment of the present invention;

[0077] FIG. 53 is an illustrative view of a needle assembly according to an embodiment of the present invention;

[0078] FIGS. 54A through 54C illustrate steps in assembling the components of a needle assembly according to an embodiment of the present invention;

[0079] FIG. 55 is an illustrative view of a needle capture device according to an embodiment of the present invention;

[0080] FIGS. 56A and 56B are enlarged partial section views of the distal end of a needle capture device, where FIG 56A illustrates the needle capture assembly in a normally closed configuration and FIG. 56B illustrates the needle capture assembly in an open configuration;

[0081] FIG. 57 is an enlarged partial section view of the needle capture assembly interlockingly engaging a needle assembly according to an embodiment of the present invention;

[0082] FIG. 58 is a perspective view of a handle assembly of an endoscopic suturing system according to an embodiment of the present invention;

[0083] FIG. 59A is a cross-sectional view of the handle assembly of FIG. 58 in a closed position with the handle assembly of the capture assembly locked in position therein;

[0084] FIG. 59B is a perspective view of the arrangement of FIG. 59A;

[0085] FIG. 59C is a perspective view of the handle assembly of FIG. 58 in an open position and with the handle assembly of the capture assembly locked in position therein;

[0086] FIG. 60A is a perspective view of a molded suture dispenser including a removable needle shield tab;

[0087] FIG. 60B is a perspective view of the suture dispenser where the needle shield tab has been removed to provide access to the needle retaining member;

[0088] FIG. 60C is an exploded perspective view illustrating the components of the molded suture dispenser;

[0089] FIG. 61A is an enlarged perspective view of the needle retaining member;

[0090] FIG. 61B is an enlarged partial cross-sectional view of the needle retaining member securing the removable needle assembly;

[0091] FIG. 62A is a perspective view illustrating the needle capture device engaging the suture dispenser;

[0092] FIG. 62B is an enlarged partial cross-sectional view of the needle capture assembly interlockingly engaging the removable needle assembly positioned within the needle retaining member of the suture dispenser;

[0093] FIG. 63 through FIG. 69 illustrate steps in a surgical suturing procedure using an endoscopic suturing system according to another embodiment of the present invention wherein FIG. 63 is a view of a step in which an endoscopic suturing device is positioned adjacent a wound at a desired treatment location;

[0094] FIG. 64 is a view of a step in which a tissue grasper is extended adjacent a wound at a desired treatment location;

[0095] FIG. 65 is a view of a step in which a tissue grasper engages tissue and is slightly retracted to bring tissue closer to the endoscope;

[0096] FIG. 66 is a view of an alternative step in which a tissue grasper engages tissue and is substantially retracted to bring tissue in contact with the endoscope;

[0097] FIG. 67 is a view of a step in which the needle partially pierces tissue;

[0098] FIG. 68 is a view of a step in which the needle completely pierces tissue;

[0099] FIG. 69 is a view of a step in which the needle holder arm is removed from the tissue depositing a suture through the tissue;

DETAILED DESCRIPTION OF THE PREFERRED EMBODIMENTS

[00100] As shown in FIG.1 an endoscope system 10 which comprises an endoscope 12, a video display unit 14, an image processing device 16, a light source 17, a suction device 18 is used with and an endoscopic suturing device 20 as part of an endoscopic treatment system according to one embodiment of the present invention. FIG. 2 and FIG. 3 illustrate respectively

the proximal and distal portions of endoscope 12 and endoscopic suturing device 20. The endoscopic suturing device 20 has an operable handle 22 which is removably coupled to endoscope 12 at a first instrument channel 24. A tissue grasper 26 which is used to gather tissue is shown positioned within a second instrument channel 28 of endoscope 12. The endoscopic suturing device 20 includes an elongate needle capture device 30 which is removably coupled to handle 22 and extends to the distal end of endoscope 12 slidably positioned within instrument channel 24. The endoscopic suturing device 20 is operated by handle 22 which is proximally coupled to transmission assembly 32 which extends distally along the exterior of insertion tube 34 to the distal end 36 of endoscope 12. The transmission assembly is coupled at its distal end to a cap assembly 38 which is positioned over the distal end 36 of endoscope 12. FIG. 3 shows the distal end 40 of needle capture device 30 and the distal end helical tip 42 of tissue grasper 36 extending from instrument channels 24 and 28 respectively. Positioned adjacent to needle capture device distal end 40 is needle assembly 44 which is connected to suture 46. Needle assembly 44 is removably inserted into needle holder arm 48. Transmission assembly 32 comprises an outer sheath 50 which is preferably formed of a flexible coil and a push rod 52 positioned within the lumen and extending from the distal end of outer sheath 50. Outer sheath 50 is fixedly secured to cap assembly 38. Push rod 52 is coupled to a connecting member 54 via a pivot pin 56, and optionally via a push member 52a which may couple the rod 52 and the pivot pin 56. The connecting member 54 is also connected to a pair of outer mounting brackets 58 via pivot pin 60. The mounting brackets 58 are fixedly attached to cap assembly 38. A pair of inner mounting brackets 62 are fixedly attached to the cap assembly 38 and pivotally connected to one end of a link member 64 via pivot pin 66. The other end of link member 64 is connected to the needle holder arm 48 via pivot pin 68. Needle holder arm 48 is coupled to connecting member 54 via pivot pin 69.

[00101] As shown in FIG. 3, FIG. 4, and FIG. 5, the pivotable connections of connecting member 54 and link member 64 to outer and inner mounting brackets 58 and 62 respectively, allow the rotation of needle holder arm 48 when push rod 52 is axially advanced or retracted. In FIG. 4, the cap assembly 38 is shown in an open configuration with push rod 52 advanced (compare FIG. 3 where the cap assembly is in a closed configuration with push rod 52 retracted). FIG. 5 shows the endoscopic suturing device 20 in an open configuration and from another angle where outer and inner pairs of mounting brackets 58 and 62 are more visible.

[00102] FIG. 6 shows a view of cap assembly 38 uncoupled from an endoscope. Cap assembly 38 includes a fixedly attached insert guide 70 coupled to a flexible channel lock 72. Insert guide 70 is a tubular projection from cap assembly 38 and is adapted to be positioned

within the lumen of an endoscope instrument channel at its distal end. The elongate flexible channel lock 72 extends from the insert guide 70 through an instrument channel and is secured to the proximal end of the instrument channel. The channel lock 72 ensures that the cap assembly 38 does not inadvertently disengage from the distal end of the endoscope. Preferably channel lock 72 takes the form of a small diameter single or multi stranded wire or cable formed primarily of metals or polymers. Additionally the small diameter of channel lock 72 allows room for other instruments to be positioned within the instrument channel of the endoscope.

[00103] FIG. 7 illustrates needle assembly 44 which comprises a needle body 74, a needle tip 76 and suture 46. The suture 46 may be formed of any materials commonly available for surgical suture such as nylon, polyolefins, PLA, PGA, stainless steel, nitinol and others. FIG. 8 shows a detailed exploded view of two components of needle assembly 44. Needle tip 76 has a sharp distal end and a hollow proximal end having a suture slot 78 through the side wall. Needle body 74 has a rounded or blunt tapered proximal end 74a adapted to fit within the needle holder arm with the proximal end 74a presenting a shoulder 79 between end 74a and the remainder of the needle body 74. A distal end 74b of the needle body 74 has a suture slot 80 adapted to concentrically engage needle tip 76. Flexible suture material is positioned on the distal end of needle body 74 extending through the aligned suture slots 78 and 80. The needle tip 76 and needle body 74 are formed from suitable biomaterials and may be made from polymers such as nylon, PEEK, PLA, PGA, PLGA or metals such as stainless steel, nitinol or titanium. The components may be joined using standard joining techniques such as thermal bonding, ultrasonic welding laser welding, adhesives or mechanical crimping. FIG. 9 illustrates an alternative needle assembly 82 having a needle tail 84 and a needle tip 86. Needle tip 86 has a sharpened distal end, a suture aperture 88 and a hollow proximal end which is adapted to receive needle tail 84. Suture 90 is positioned within the hollow end of needle tip 86 and extends through aperture 88. Needle tail 84 and suture 90 are secured in the hollow end of needle tip 86 using any of the aforementioned joining techniques. Needle tail 84 is preferably formed in a straightened shape and of a resilient material such as nitinol. When needle tail 84 is placed in a curved needle holder arm the needle tail bends and applies a force to the inner wall of the needle holder arm maintaining the needle assembly 82 securely in place.

[00104] FIG. 10 through FIG. 13A illustrate alternate versions of needle assemblies for use in closing tissue defects. FIG. 10 shows a needle clip 92 in a straightened configuration having a body portion 94 a proximal beaded end 96 and a piercing tip 98. The needle clip 92 is preferably formed of nitinol or other resilient material and biased into a generally circular shape. Needle clip 92 may be constrained in a generally straightened configuration but when

unconstrained transitions to its biased generally circular configuration as shown in FIG. 11. FIG. 12 shows an alternate needle clip 100 having a proximal bead 102, a piercing tip 104, an outer coil covering 106, and a body portion 108 connecting the proximal and distal ends. The needle clip 100 also includes a securing member 110 to fixedly attach at least a portion of coil 106 to body portion 108. The needle clip 100 is preferably comprised of nitinol or other resilient material and is biased into a generally circular shape. Needle clip 100 may be constrained in a generally straightened configuration but when unconstrained transitions to its biased generally circular configuration as shown in FIG. 13. The coil 106 may be formed of suitable biomaterials such as polymers of nylon, polyester, PEEK, PLA, PGA, PLGA or metals such as stainless steel, nitinol, titanium or platinum. The coil 106 provides increased surface area for tissue in growth and encapsulation as well as distributing the force placed on tissue when closing a tissue defect. FIG. 13A shows a needle clip 100 in which the coil 106 extends over the sharp piercing tip thereby shielding the tip from inadvertent damage to surrounding tissue.

[00105] FIG. 14 shows the tissue grasper 26 which has a proximal handle 108, an elongate shaft member 110 and a helical tip 42. Shaft member 110 is formed of a wire or multi-stranded cable or any torque transmitting configuration that provides flexibility which does not impede the steering capabilities of the endoscope. FIG. 15 shows an enlarged view of the distal end of tissue grasper 26. Shaft member 110 is coupled to helical tip 42 by tip coupling member 112. Tip coupling member 112 may be fixedly joined to helical tip 42 and shaft member 110 by any of the aforementioned joining techniques.

[00106] FIG. 16 and FIG. 17 show a cinch deployment system 114 for securing suture placed at a tissue defect site. The cinch deployment system 114 comprises a cinch assembly 116 and a cinch delivery device 118. The cinch delivery device 118 has an elongate flexible tubular shaft 120 which is removably coupled at its distal end to cinch assembly 116 and fixedly attached at its proximal end to handle member 122. Handle member 122 includes a slidable finger ring assembly 124 and a thumb ring 126. Slidably disposed within the lumen of tubular shaft 120 is push rod 128. Push rod 128 extends from the distal end of tubular shaft 120 to the proximal end of tubular shaft 120 and is coupled to the slidable finger ring assembly 124 with fixation screw 130, such that movement of the finger ring assembly relative to the thumb ring 126 causes the axial movement of push rod 128 within the lumen of tubular shaft 120. A partially exploded view of the distal end of the cinch deployment system 114 is shown in FIG. 18. As depicted, push rod 128 extends from tubular shaft 120 and through latch assembly 129. Latch assembly 129 is fixedly attached to tubular shaft 120 and has two latch arms 132 with latch tabs 134 at their distal ends. Latch arms 132 are biased inwardly towards the central

longitudinal axis of tubular shaft 120. Latch assembly 129 is positioned within the lumen of a latch coupling 136 and is fixedly secured. Latch coupling 136 is configured at its distal end to engage with the proximal end of cinch 116 such that the latch arms 132 extend within the proximal lumen of cinch 116 and when push rod 128 is positioned within latch assembly 129 the latch arms 132 are forced outwardly such that the latch tabs 134 locking engage the cinch tab apertures 138. When push rod 128 is axially retracted from latch assembly 129 the latch arms 132 move inwardly towards their biased configuration causing latch tabs 134 to release their locking engagement with cinch tab apertures 138 to thereby release the cinch assembly 116. FIG. 19 illustrates the cinch assembly 116 in an open configuration. Cinch assembly 116 has a tubular housing member 139 having cinch tab apertures 138 located at its proximal end and a suture hook 140 fixedly attached at its distal end. A securing clasp 142 is slidably positioned within the lumen of housing member 139. A retention tab 144 is preferably formed from the wall of housing member 139 and biased inwardly towards the central axis of housing member 139 at its distal end. When suture has been captured by suture hook 140 the suture may be secured within cinch assembly 116 by advancing push rod 128 such that securing clasp 142 extends from housing member 139 and engages suture hook 140. With securing clasp 142 in extended configuration retention tab 144 moves to its inwardly biased configuration restricting the proximal movement of the securing clasp 142 thereby fixing the suture in place.

[00107] FIG. 21 illustrates a guide tube 146 for use in an endoscopic procedure. Guide tube 146 has a proximal end 148 including a lumen 150 that extends to the distal end 152. Generally a guide tube 146 is positioned in a patient to provide a conduit to a desired location while protecting the surrounding tissue from inadvertent damage. As shown in FIG. 22 and FIG. 23 show a guide tube 146 with an endoscopic suturing device 20 positioned in the lumen 150. Once the guide tube 146 is positioned at a desired treatment location within the body the distal end of the endoscopic suturing device 20 may be extended beyond the distal end of the guide tube 146.

[00108] FIG. 24 through FIG. 34 depicts a method of performing a suturing operation using an endoscopic suturing device 20 of the present invention. As shown in FIG. 24, the endoscopic suturing device 20 is positioned adjacent tissue 154 which has a tissue defect 156 to be closed. The endoscopic suturing device 20 is in an open configuration. FIG. 25 shows the tissue grasper 26 extended from the endoscope instrument channel such that helical tip 42 is adjacent tissue defect 156. Rotation of the tissue grasper 26 causes the helical tip 42 to securely engage the tissue 154 adjacent to the tissue defect 156. The tissue 154 may be brought closer to the endoscope by slightly retracting the tissue grasper 26 into the instrument channel of the

endoscope as shown in FIG. 26. The degree of tissue retraction correlates to the size and location of the stitch. For instance, to have a larger amount of tissue sutured, the tissue 154 may be brought into contact with the endoscope by the tissue grasper as shown in FIG. 27. The needle holder arm 48 is actuated to move to a closed position causing the needle assembly 44 to pierce tissue 154. The suture 46 is pulled through the tissue as shown in FIG. 28. The control over the amount of tissue retracted allows the physician the ability to perform a partial thickness stitch within the wall of a tissue or a full thickness stitch which extends through a wall of tissue. The needle capture device captures the needle assembly 44 by gripping it at shoulder 79 (FIG. 7) and removes it from the needle holder arm 48 (not shown). FIG. 29 shows the needle holder arm 48 moved to an open configuration and removed from tissue 154. Suture 46 remains through the tissue. FIG. 30 shows the lengthening of the suture 46 through the tissue 154 by retracting the endoscopic suturing device 20 while retaining the needle assembly 44 within the needle capture device. FIG. 31 shows the needle holder arm 48 moved to a closed configuration and needle assembly 44 reinserted into the needle holder arm 48 by advancing the needle capture device if the physician wishes to make another stitch. If the physician does not wish to make another stitch, the needle assembly with suture can be retracted through the endoscope channel and with both ends of the suture, a knot can be tied and pushed down the endoscope channel to the treatment site to secure the tissue. Alternatively, the suture can be secured using a cinch deployment system. As shown in FIG. 32 a cinch assembly 116 and a cinch delivery device 118 may be used to capture the suture 46. The suture may be pulled tight to securely close the tissue defect 156. Once the tissue defect 156 is sufficiently closed the cinch assembly 116 may be moved to a closed configuration, thereby securing the suture 46 as shown in FIG. 33. The cinch delivery device 118 can release the cinch assembly 116 as shown in FIG. 34 and the suture 46 may then be cut using any standard cutting means such as scissors. It is contemplated that the cinch assembly may incorporate cutting means after securing the suture.

[00109] FIG. 35 through FIG. 38 shows another method of closing a tissue defect and securing the suture. FIG. 35 shows the endoscopic suturing device 20 having delivered a needle assembly 44 (shown schematically) and suture 46 through tissue 154 adjacent a tissue defect 156 where the needle assembly 44 is resting adjacent the surface of tissue 154. FIG. 36 shows a cinch deployment system having a cinch assembly 116 and a cinch delivery device 118 that has grasped a portion of suture 46. The suture is pulled tight to close the tissue defect 156 while the needle assembly prevents the end of suture 46 from pulling through the tissue 154. Once the tissue defect 156 is sufficiently closed the cinch assembly 116 may be moved to a closed configuration, thereby securing the suture 46 as shown in FIG. 37. The cinch delivery device

118 can release the cinch assembly 116 as shown in FIG. 38 and the suture 46 may then be cut using any standard cutting means such as scissors.

[00110] FIG. 39 through FIG. 42 shows still another method securely closing a tissue defect. FIG. 39 shows an endoscopic suturing device 20 having an open configuration and a needle clip 100 having a proximal bead 102 and a piercing tip 104 positioned in needle holder arm 48. The helical tip 42 of the tissue grasper 26 has engaged tissue 154 adjacent to the tissue defect 156 and retracted the tissue towards the endoscope. FIG. 40 shows the needle holder arm 48 in a closed configuration positioned through the tissue with the piercing tip 104 of needle clip 100 having pierced and exited the tissue. FIG. 41 shows the needle capture device grasping the piercing tip of the needle clip 100 with the needle holder arm 48 in an open configuration and removed from tissue 154. The proximal bead 102 of needle clip 100 is positioned adjacent the tissue site initially pierced by the piercing tip. FIG. 42 shows the release of tissue 154 from the tissue grasper and the resilient needle clip 100 taking its pre-biased generally circular shape thereby closing the tissue defect 156. As can be appreciated, the application of a tissue sealant or adhesive may be used to aid in the closing the tissue defect.

[00111] FIG. 43 shows an endoscopic suturing device 320 according to another embodiment of the present invention. Endoscopic suturing device 320 includes a cap assembly 322 which is adapted to engage with the distal end of an endoscope, an elongate channel lock member 324 which is optionally removable from cap assembly 322, an outer sheath 326, an inner sheath 328 and an elongate flexible transmission member 330. As seen in FIG. 44, cap assembly 322 further includes a fixedly attached channel lock receiver 332, an endoscope channel insert guide 334, an elongate tissue guard 336, an elongate needle guard 338 which extends distally from the base of the cap assembly and houses the mechanical assembly that provides rotational motion for needle holder arm 340 as shown in FIG 44. Channel insert guide 334 is a tubular projection from cap assembly 322 and is adapted to be positioned within the lumen of an endoscope instrument channel at its distal end. The elongate flexible channel lock member 324 extends from the channel lock receiver 332 through an instrument channel and is secured at the proximal end of the instrument channel. The channel lock member 324 ensures that the cap assembly 322 does not inadvertently disengage from the distal end of the endoscope. Preferably channel lock member 324 takes the form of a small diameter single or multi stranded wire or cable formed primarily of metals or polymers. Additionally the small diameter of channel lock 324 allows room for other instruments to be positioned within the instrument channel of the endoscope. FIGS. 44 and 45 respectively show the cap assembly 322 in a needle arm 340 closed configuration and a needle arm open configuration.

[00112] For purposes of example only, and not by way of limitation, in the shown embodiment, the cap assembly 322 has a cap or ring element 322a having an inner diameter of approximately 13.5mm, an outer diameter of approximately 14.2mm, a height of a little over 2mm, and a portion 322b having a rim width of between 1mm and 2mm.

[00113] For purposes of example only, and not by way of limitation, in the shown embodiment, the elongate tissue guard 336 circumscribes approximately 50° of the ring 322a on its outside surface 336a and extends vertically approximately 9mm over the top of the ring element 322a at its middle portion. The inside surface 336b of the elongate tissue guard 336 is generally semicircular (thereby helping define side walls 336d) and defines an approximately 4mm – 5mm opening which extends above a smaller ring 322c (see FIG. 48) of the cap assembly and above a channel of the endoscope into which the needle capture device (described hereinafter with reference to Figs. 55-57) is to be located. This channel may be the same channel of the endoscope into which the channel insert guide 334 is inserted as described hereinafter. The top surface 336d of the elongate tissue guard 336 is angled at an approximately 45° angle. With the provided arrangement, and as discussed hereinafter with reference to Figs. 63-69, the tissue guard 336 helps fold tissue for stitching and helps prevent tissue which is drawn into the cap assembly from clogging the endoscope channel and preventing stitching.

[00114] For purposes of example only, and not by way of limitation, in the shown embodiment, the elongate needle guard 338 has a height of between approximately 18mm and 19mm, and forms an arched opening between two arms 338a, 338b which have outside surface spaced approximately 5mm apart from each other and inside surfaces spaced approximately 3.7mm from each other. The arms are joined by a top arch 338c and an optional cross-member (stop) 338d located below the arch 338c. In between the arms and below cross-member 338d is a gear linkage 342 described hereinafter. In addition, the curved needle holder arm 340 is arranged such that when a needle is held in the needle holder arm 340, in a fully open position, the tip of the needle is preferably located under the arch 338c and between the arms 338a, 338b. The holder arm 340 can then rotate into a closed position through the arched opening above the gear linkage. Each arm 338a, 338b has a width of approximately .64 mm and a radial thickness of approximately 2.5mm.

[00115] FIG. 46 shows a detailed exploded view of cap assembly 322. Needle holder arm 340 includes a first end 340a which is adapted to frictionally engage a needle assembly, and a second end 340b is fixedly secured to needle arm gear link 342 (e.g., in a receiving hole 342a defined therein). By way of example only and not by way of limitation, needle holder arm 340 bends through an arc of approximately 90°. Gear link 342 is mounted between needle guard

arms 338a, 338b and includes a gear portion 344 which is mounted using pivot pin 345 through mounting hole 346 in gear link 342 to mounting holes (first mounting locations) 347 defined in the housing (arms) of needle guard 338, and an arm or extension portion 343. Gear portion 344 includes lateral gear teeth 344a. Similarly, push member gear link 348 includes gear portion 350a with lateral gear teeth 350b which mesh with gear teeth 344a, and an arm 350c. Gear link 348 is mounted using pivot pin 351 through mounting hole 352 to mounting holes (second mounting locations) 353 defined in the housing (arms) of needle guard 338. Gear link 348 is also coupled through mounting hole 354 in arm 350c to push member joint 356 using pivot pin 357 and mounting bracket 358. Push member joint 356 is fixedly coupled to transmission member 330. FIGS. 47 and 48 show cap assembly 322 assembled where gear portion of gear link 348 intermeshes with gear portion of gear link 342 such that when transmission member 330 is advanced gear link 348 rotates and its gear portion causes the gear portion of gear link 342 to rotate causing needle holder arm 340 to move to a closed position. In the closed position, arm 343 of gear link 342 extends around and above gear link 348 and between cross-member 338d and arch 338c. In the open position (FIG. 45), the arm 343 of gear link 342 extends radially outward relative to needle guard arms 338a, 338b, and the back of the arm 350c may engage the edge of cross-member 338d which can act as a stop to gear movement.

[00116] Cap assembly 322 may also include a wash deflector 360 as shown in FIG. 48. The wash deflector redirects fluid from the endoscope to wash the gear mechanism to remove debris. The aforementioned components are all preferably made from biocompatible metals such as stainless steel and titanium although some high strength polymers may be suitable. The vertical positioning of mounting holes 347 and 353 in the needle guard arms 338a, 338b reduces the profile of cap assembly 322 and facilitates delivery of the endoscopic suturing device 320 to a treatment site.

[00117] To aid in the retention of cap assembly 322 on the distal end of the endoscope FIGS 49 and 50 illustrate views of cap assembly 322 where channel lock member 324 is optionally removably secured in channel lock receiver 332 by channel lock retention member 362. Preferably retention member 362 is formed of a large bead fixedly secured to the distal end of channel lock member 324, whereas channel lock receiver 332 defines a groove 333 having a width smaller than the width of the bead. If desired, the channel lock wire or cable 324 can be welded or otherwise fixed to the channel lock receiver 332 or to another part of the cap assembly. An additional mechanism to increase the retention of the cap assembly to the distal end of the endoscope is show in FIG 50 where the channel insert guide 334 has a partially split structure (i.e., one or more longitudinal slits 335 are provided). The two portions of the split may

be biased outwardly such that when they are placed in the instrument channel of the endoscope they apply an outward force to the inner wall of the channel thereby aiding in the retention of the cap assembly to the distal end of the endoscope. FIGS. 51 and 52 show how tension is applied to channel lock member 324 and maintained at the proximal end of the endoscope by using a channel lock tensioner 365 that secures the proximal channel lock retention member 366 secured to the proximal end of the channel lock member. The channel lock tensioner 365 includes a bayonet lock connector 370, which couples to the endoscope instrument channel and a spring 372 which supports a tensioner housing 374 coupled to a rotatable tensioning wheel 376 having a tab member 378. The proximal end of channel lock member 324 is threaded through tensioner housing 374 and through a valve located at the top of the housing, and is positioned within a tab receptacle 380. The tab receptacle 380 secures channel lock retention member 366 to the tensioner wheel 376. The tensioner wheel 376 can then be rotated (e.g., clockwise) to apply the appropriate tension on the channel lock member and then locked into place by a locking element (not shown). Spring 372 is used to compensate, by compressing, for the bending of the endoscope to maintain a constant tension on the channel lock member. Alternatively, instead of providing a spring 372 between the bayonet lock 370 and the tensioner housing 374, the spring can be provided on the wheel 376 to spring load the wheel toward a desired position (e.g., the position of FIG. 51). As the channel lock member 324 is bent along with the scope through a tortuous path, wheel 376 can rotate against the force of the spring to maintain the desired tension on the channel lock member 324.

[00118] FIG. 53 illustrates needle assembly 400 which comprises suture 402, a needle tip 404, a lock gap 405 and a needle body 406. The suture 402 may be formed of any materials commonly available for surgical suture such as nylon, polyolefins, PLA, PGA, stainless steel, nitinol and others. FIGS. 54A through 54C show detailed exploded views of the components of needle assembly 400. Needle tip 404 has a sharp distal end and a hollow proximal end with a swage lip 408. Needle body 406 has a proximal end adapted to fit within the needle holder arm 340 and a distal end having a suture slot 410. Needle body 406 is adapted to concentrically engage needle tip 404 and create lock gap 405. Flexible suture material 402 is positioned on the distal end of needle body 406 extending through the suture slot 410. The needle tip 404 and needle body 406 are formed from suitable biomaterials and may be made from polymers such as nylon, PEEK, PLA, PGA, PLGA or metals such as stainless steel, nitinol or titanium. The components may be joined using standard joining techniques such as thermal bonding, ultrasonic welding laser welding, adhesives or mechanical crimping.

[00119] FIG. 55 illustrates a needle capture device 450, which includes an elongate catheter or tube 452 having at its distal end a needle capture assembly 454 and at its proximal end a button actuator 456 coupled to handle assembly 458. By way of example only, and not by way of limitation, the needle capture device 450 is a 3mm tool in that the tube 452 and the distal end needle capture assembly 454 are preferably at most 3mm in diameter. The handle assembly 458 is preferably adapted to be coupled to the handle assembly operating the needle holder arm of the endoscopic suturing device 320 for ease of use. Toward that end, handle assembly 458 is provided with a deflecting tooth lock 459a and a generally rigid tooth 459b which are arranged to engage with reciprocal cavity and locking element in the handle assembly 600 of the suturing device 320 as discussed below with reference to Figs. 58 and 59A-59C.

[00120] FIGS. 56A and 56B show an enlarged partial cross-sectional view of needle capture assembly 454 and the distal end 460 of tube 452 in closed and open configurations respectively. Slidably positioned within the lumen of tube 452 is push rod or cable 462 which has a proximal end mechanically coupled to button actuator 456 and a distal end coupled to actuator pin 464. Actuator pin 464 is positioned within an angled slot 465 defined in lever arm 466 adjacent fixed pivot pin 468. At the distal end of lever arm 466 is an interlock feature 470. The distal inner portion of needle capture assembly 454 forms needle receptacle 472. Button actuator 456 incorporates a spring assembly which places push rod 462 under a tension load thereby causing lever arm 466 to remain in an engaged or closed configuration as shown in FIG. 56A. When button actuator 456 is depressed, push rod 462 is advanced, thereby causing lever arm 466 and interlock feature 470 to a disengaging or open configuration as shown in FIG. 56B. FIG. 57 illustrates needle assembly 400 positioned within needle receptacle 472 of needle capture assembly 454. As shown, needle assembly 400 is secured in place by the interlocking engagement of interlock feature 470 and lock gap 405. In this configuration needle capture device 450 can be used to deliver the needle through the instrument channel of the endoscope to load the needle assembly into needle holder arm 340.

[00121] A handle assembly 600 for the endoscopic suturing device 320 is seen in FIG. 58 and 59A-59C. The handle assembly 600 includes a first stationary handle 604 and a second rotatable handle 608 which is rotatably coupled to stationary handle by pivot axle 612. The rotatable handle 608 is spring-biased to the open position seen in FIG. 58 by a spring 614 which sits and is fixed between the handles. The stationary handle 604 defines a proximal cavity 616 for receiving the handle assembly 458 of the needle capture device 450. Extending from the stationary handle 604 is a tube 618 which terminates in a port 620. Port 620 includes a fluid valve 622 and a mechanical bayonet lock 624 for coupling to the proximal end of an endoscope.

Also extending from the stationary handle is sheath 328 which houses the transmission wire 330. Second handle 608 defines a fingers grip section 626, and ratcheted locking element 628 at its proximal end. As described hereinafter, the rotatable second handle 608 is coupled to the transmission wire 330. Movement of the rotatable handle towards the fixed handle causes axial movement (retraction) of the transmission wire 330. Movement of the rotatable handle away from the fixed handle causes axial movement (extension) of the transmission wire 330 in an opposite direction.

[00122] Turning now to Figs. 59A-59C, additional details of the handle assembly 600 are seen in addition to how the handle assembly 458 of the needle capture device 450 interacts with the handle assembly 600 of the endoscopic suturing device 320. More particularly, as seen in FIG. 59A, pivotably coupled to the inside of first handle 604 by pivot pin 632 is an actuation pivot element 634. The transmission wire 330 is coupled to the actuation pivot element 634 at a second location 636 by a spring 638 which can move in a predetermined distance in a cavity 639 defined by fixed handle 604. The rotatable handle 608 is also coupled to the actuation pivot element 634 at a third location 640 by bracket 642 which is coupled to the rotatable handle 608 by post 644. As a result, rotation of the handle 608 (i.e., squeezing) toward the closed position of FIG. 59A causes bracket 642 to pull location 640 of the actuation pivot element 634 downward. Movement of location 640 downward in turn is accompanied by clockwise rotation of the actuation pivot element 634 about pivot pin 632, and thus backward (clockwise) movement of the connection between spring 638 and the actuation pivot element 634 at location 636. Movement of spring 638 backward pulls transmission wire 330 backward.

[00123] Also seen in FIG. 59A is the interaction of handle assembly 600 with the handle assembly 458 of the needle capture device 450. More particularly, the stationary handle 604 is provided with a catch 648 which extends into cavity 616 and is designed to engage the flexible tooth (latch) 459a of the needle capture device handle assembly 458. In addition, cavity 616 has a bottom proximal ledge 650 for receiving rigid tooth 459b. Tube 618 which extends out of the stationary handle 604 extends into a tubular cavity 654 of the stationary handle 604 which houses a spring 656, thereby spring loading tube 618 outward.

[00124] When it is desired to extend the needle capture device 450 with its distal needle capture assembly 454 through the endoscope, the distal end of the needle capture assembly is threaded into cavity 616 of the stationary handle 604, tubular cavity 654, tube 618, port 620 and then into the endoscope. The needle capture assembly 454 is pushed through until the handle 458 engages the cavity 616 of the stationary handle 604. When pushed as far as possible, rigid tooth 459b aligns with ledge 650, and flexible latch 459a engages catch 648, thereby locking the

needle capture device 450 in place. Cable 462 of the needle capture device 450 with sheath 452 extends from the button actuator 457 through the tubular cavity 654, through the tube 618, and through and out of the port 620. To actuate the needle capture assembly, button 456 is pushed as previously described. Disconnection of the needle capture device 450 from the handle assembly 600 is obtained by pressing down on a relieved portion 459c of the handle 458 adjacent and proximal the latch 459a, thereby causing the latch to disengage from the catch 648, and pulling proximally on the handle 458.

[00125] As seen best in Figs. 59B and 59C, the needle capture device handle 458 is preferably provided with a ratchet locking extension or (hooked) tooth 459d. When the needle capture assembly 450 is in place in the handle 600 assembly of the endoscopic suturing device, the handles 604 and 608 may be locked into place in a closed position by engaging ratcheted locking element or tooth 628 on rotatable handle 608 with the similar ratcheted locking extension or tooth 459d of the needle capture assembly 450 (which in turn is locked in stationary handle 604) as seen best in FIG. 59C. As will be appreciated, the teeth 628 and 459d are generally laterally offset, but include hooked portions which after sliding past each other, will engage or grip each other, thereby locking in place. Disengagement is obtained by applying a relative lateral force to one or both of the handles.

[00126] An innovative suture dispenser 500 having a dispenser body 502 and a removable needle shield tab 504 is shown in FIG 60A. The suture dispenser 500 is shown in FIG 60B with the needle shield tab 504 removed from the dispenser revealing a needle retaining member 506. To better illustrate the suture dispenser 500, FIG. 60C shows an exploded perspective view of the components. Suture dispenser 500 includes a lower body 508 and upper body 510 which together form a cavity which houses suture spool 512 containing suture 402, needle shield 504 and needle retaining member 506. The lower and upper bodies 508, 510 preferably include ribs 508a, 508b (similar ribs on upper body not shown) on and about which spool 512 rests so that spool 512 can rotate with a minimum of friction in the cavity. The lower and upper bodies 508, 510 are also each preferably provided with walls 513a, 513b, 513c (seen in FIG. 60C only with respect to lower body 508) which retain the needle retaining member 506 in place but permit the needle shield tab 504 to be removed. More particularly, wall 513a is seen to form a back wall for the needle retaining member. It includes a cutout or orifice 513d for receiving a rear portion of the needle retaining member (and needle) and it angles at 513e to join outer wall 513c. Wall 513b is a low wall which is placed in between walls 513a and 513c and is connected to the angled portion 513e of wall 513a. Wall 513b effectively forms two grooves with the first groove seating the needle retaining member 506 and holding it in place and the second groove

seating a portion of the needle shield tab 504. Needle shield tab, however extends out of a radial opening or orifice in outer wall 513c and can be pulled out (i.e., can slide out) completely to reveal a receiving cavity 514 in the needle retaining member 506. The outer wall 513c is also provided with an opening or orifice 513f in front of the receiving cavity 514. The suture dispenser 500 and most of its components are easily fabricated at low cost using suitable polymers, such as polyethylene, polypropylene or polystyrene, injection molding and preferably designs which snap together (e.g., latches 508c and hollow receiving post 508d on lower body 508, and catches 510c and post (not shown) on upper body 510).

[00127] As seen in FIG. 60B, needle shield 504 is preferably provided with prongs 504a. The prongs are squeezably held between ribs (not shown) extending from the lower and upper bodies 508, 510 in order to hold the needle shield 504 in place. However, because the prongs are resilient, application of force to the tab portion 504b of the needle shield 504, permits the needle shield 504 to be removed from the dispenser body 502.

[00128] As previously mentioned, needle retaining member 506 includes a needle receiving cavity 514 as shown in FIGS. 61A and 61B where removable needle assembly 400 is held. As shown in the partial cross-section view of FIG. 61B, needle body 406 is frictionally held within an orifice 514a defined in the body of retaining member 506 (in much the same manner it is frictionally held in the needle holder arm 340 (FIG. 46) and the needle is connected to suture 402 which is wound on the suture spool. Needle tip 404 is accessible to the needle capture assembly 454 through needle receiving cavity 514; i.e., the cavity provides room around the needle tip to permit the needle capture assembly to enter the cavity and grab the needle. Also as shown in FIG. 61B, the needle retaining member 506 has laterally elongated upper and lower flanges 514b which are receiving and seat in the grooves formed by the walls 513a, 513b of the lower and upper bodies 508, 510 of the suture dispenser 500. The body of the needle retaining member has a cylindrical portion which extends backward through the orifice 513d of the inner wall 513a.

[00129] FIGS. 62A and 62B show the suture dispenser 500 receiving the needle capture assembly 454 of needle capture device 450. FIG. 62B shows a partial cross section view of the needle capture assembly 454 interlockingly engaged with the needle for removal from the dispenser.

[00130] FIG. 63 through FIG. 69 depicts a method of performing a suturing operation using an endoscopic suturing device 320 of the present invention. As shown in FIG. 63, the endoscopic suturing device 320 is positioned adjacent tissue 154 which has a tissue defect 156 to be closed. The endoscopic suturing device 320 is in an open configuration and the tip of needle

assembly 400 is shrouded by needle guard 338. FIG. 64 shows the tissue grasper 26 is extended from the endoscope instrument channel such that helical tip 42 is adjacent tissue defect 156. Rotation of the tissue grasper 26 causes the helical tip 42 to securely engage the tissue 154 adjacent to the tissue defect 156. The tissue 154 may be brought closer to the endoscope by slightly retracting the tissue grasper 26 into the instrument channel of the endoscope as shown in FIG. 65. During the retraction of tissue, the needle guard 338 prevents the tissue from dragging against the tip of needle assembly 400, thereby reducing inadvertent tissue damage. The degree of tissue retraction correlates to the size and location of the stitch. For instance to have a larger amount of tissue sutured, the tissue grasper may bring the tissue 154 close to the endoscope as shown in FIG. 66. When attempting to suture a large amount of tissue, the position of the angled distal end of tissue guard 336, in conjunction with the needle guard 338, aids in folding the tissue in preparation for suturing and preferably aids in preventing the tissue from locating immediately adjacent and thereby clogging the needle capture device. The needle holder arm 340 is actuated to move to a closed position causing the needle assembly 400 to pierce tissue 154. The angled portion of tissue guard 336 provides support for the tissue allowing the needle to more easily penetrate the tissue as shown in FIG. 67. The suture 402 is pulled through the tissue as shown in FIG. 68. The control over the amount of tissue retracted allows the physician the ability to perform a partial thickness stitch within the wall of a tissue or a full thickness stitch which extends through a wall of tissue. The needle capture device captures the needle assembly 400 and removes it from the needle holder arm 340(not shown). FIG. 69 shows the needle holder arm 340 moved to an open configuration and removed from tissue 154. Suture 402 remains through the tissue. To continue a running stitch, the needle holder arm can be reloaded with the needle assembly without needing to remove the endoscopic suturing device from the body as previously described. If only one stitch is required the suture may be tied into a surgical knot or a cinch device used to secure the suture, thereby closing the tissue defect.

[00131] The present invention has been described in conjunction with the preferred embodiments shown in various drawings. Obviously, however, other similar embodiments can be used to realize the same functions as those of the present invention, the above embodiments can be modified, or other embodiments can be added. The present invention is not therefore limited to any single embodiment. For example, each treatment device described above can be used together with a rigid endoscope, trocar, or the like as well as flexible endoscopes. Also, while particular sizes and shapes were described with respect to the end cap, needle guard, tissue guard, etc. of a particular embodiment, other sizes and shapes could be utilized. For purposes of understanding the specification and claims, where the terms “substantially” or

“approximately” are used, they should be understood to provide a range of plus or minus 20%, For example, an angle of “approximately 180 degrees” should be understood to include an angle in the range of 144 to 216 degrees. A size of “substantially 2mm” should be understood to include a size in the range of 1.6 to 2.4mm. Further, it should be appreciated that different aspects of each embodiment can be used in conjunction with the other embodiment. By way of example only, the handle assemblies for the needle capture device and for the endoscopic suturing device described with reference to Figs. 55 and 58-59C, can be used in conjunction with the needle capture device and endoscopic suturing device of the first embodiment (FIG. 1). It will therefore be appreciated by those skilled in the art that yet other modifications could be made to the provided invention without deviating from its spirit and scope as claimed.

What is claimed is:

1. A treatment device for use with an endoscope or guide member and a needle which is used to perform treatment in a body by being operated outside the body, comprising:

a flexible member having a distal end portion which is capable of being inserted into the body through or adjacent the endoscope or guide member;

a cap assembly which is arranged at the distal end portion of the endoscope or guide member and having a link mechanism actuated by an operation outside the body; and

a needle holder arm which is adapted to hold the needle and is coupled to and is actuated by the link mechanism and is able to move in a first direction to cause the needle to puncture a tissue and in a second direction opposite said first direction.

2. A treatment device according to claim 1, wherein:

said flexible member extends adjacent the endoscope and is a transmission element coupled to said link mechanism.

3. A treatment device according to claim 2, further comprising:

a handle which moves and causes said transmission element to actuate said link mechanism.

4. A treatment device according to claim 2, wherein:

said cap assembly has at least one fixedly attached mounting bracket and said link mechanism includes a first connecting member pivotally coupled to said mounting bracket.

5. A treatment device according to claim 4, wherein:

said at least one fixedly attached mounting bracket comprises an outer mounting bracket and an inner mounting bracket, and said link mechanism includes (i) said first connecting member pivotally coupled to one of said outer mounting bracket and said inner mounting bracket, and (ii) a second connecting member pivotally connected to the other of said outer mounting bracket and said inner mounting bracket and pivotally connected to said curved needle holder arm.

6. A treatment device according to claim 2, wherein:

said link mechanism comprises (i) a first gear element pivotally coupled to said transmission element and to said at least one mounting bracket, and (ii) a second gear element pivotally coupled to said at least one mounting bracket and coupled to said curved needle holder arm, and meshing with said first gear element, such that movement of said transmission element results in movement of said curved needle holder arm.

7. A treatment device according to claim 1, wherein:

said flexible member comprises a needle capture device adapted for insertion through the endoscope.

8. A treatment device according to claim 1, wherein:

said flexible member comprises a tissue grasper adapted for insertion through the endoscope or guide member.

9. A treatment device according to claim 1, wherein:

said flexible member comprises includes a channel lock member adapted for insertion through the endoscope or guide member.

10. A treatment system comprising the treatment device according to any of claims 1-6, and further comprising a needle capture device adapted for insertion through the endoscope or guide member.

11. A treatment system according to claim 10, further comprising:

a tissue grasper adapted for insertion through the endoscope or guide member.

12. A treatment system according to claim 10, further comprising:

a channel lock member adapted for insertion through the endoscope or guide member.

13. A treatment device or system according to any previous claim, further comprising:

said needle, wherein said needle is removably coupled to said needle holder arm.

14. A treatment device or system according to claim 13, further comprising:
a tissue securing member coupled to said needle.
15. A treatment device or system according to any previous claim in conjunction with said endoscope or guide member, said endoscope or guide member having at least one instrument channel.
16. A treatment system according to claim 14, wherein said endoscope or guide member has a first instrument channel and a second instrument channel.
17. A treatment system according to claim 11, wherein said endoscope or guide member has imaging capabilities.
18. A treatment device or system according to any previous claim, wherein:
said needle holder arm is curved.
19. A treatment device for use with an endoscope or guide member which is used to perform treatment in a body by being operated outside the body, comprising:
a cap assembly arranged at the distal end portion of said endoscope or guide member and having an end effector;
transmission means extending outside said endoscope or guide member and coupled to said cap assembly for actuating said end effector by an operation outside the body; and
a wire or cable element extending through the endoscope or guide member and arranged to either directly couple to the cap assembly or to include a second end effector adapted to interact with the end effector of said cap assembly.
20. A treatment device according to claim 19, wherein:
said end effector of said cap assembly includes a needle, and said wire or cable element is part of a needle capture instrument which includes a second end effector adapted to interact with the needle by capturing said needle.
21. A treatment device according to claim 19, wherein:

said needle capture instrument includes a handle element for longitudinally moving said wire or cable, and said second end effector includes a movable arm coupled to said wire or cable.

22. A treatment device according to claim 22, wherein:

said movable arm includes a distal tooth.

23. A treatment device according to claim 19, wherein:

said wire or cable element is a channel lock element which directly couples to the cap assembly and includes a proximal hub coupled to a proximal end of the endoscope or guide member, wherein said channel lock element is kept in tension in order to keep said cap assembly on said distal end portion of said endoscope or guide member.

24. A treatment system for use with an endoscope or guide member having a proximal end and a distal end and at least one channel, which treatment system is used to perform treatment in a body by being operated outside the body, comprising:

a first device coupled to the distal end of the endoscope or guide member, said first device having a proximal first handle assembly, a distal first end effector, and a first transmission element coupled to said first handle assembly and to said first end effector and extending outside the endoscope or guide member; and

a second device having a proximal second handle assembly, a distal second end effector, and a second transmission element coupled to said second handle assembly and said second end effector, said second transmission element adapted to extend through the channel of the endoscope or guide member, wherein

said first device has a first engaging element and said second device has a second engaging element, and said first engaging element and said second engaging element lock together.

25. A treatment system according to claim 24, wherein:

one of said first end effector and said second end effector is a needle, and the other of said first end effector and said second end effector is a needle capture element.

26. A treatment system according to claim 24, wherein:

said first engaging element is a first locking element on said first handle assembly, and said engaging element is a second locking element on said second handle assembly.

27. A treatment system according to claim 26, wherein:

said first locking element is one of a latch and a catch, and said second locking element is the other of said latch and said catch.

28. A treatment system according to claim 26, wherein:

said first handle assembly includes a pivot element, a first handle coupled to said pivot element, and a second handle coupled to said pivot element and arranged such that said first handle pivots relative to said second handle, and

said first handle includes a third engaging element and said second handle assembly includes a fourth engaging element, wherein said third and fourth engaging elements lock together.

29. A treatment system according to claim 28, wherein:

said third engaging element and said fourth engaging element are laterally displaced relative to each other and include portions which engage one under the other.

30. A treatment device for use with an endoscope with a channel which is used to perform treatment in a body by being operated outside the body, comprising:

a cap assembly arranged at the distal end portion of said endoscope, said cap assembly having a proximally extending endoscope channel engaging element and an end effector; and

a tensioning assembly including a wire or cable element and a tensioning element, said wire or cable element extending through the endoscope and having a distal end coupled to the cap assembly and a proximal end coupled to said tensioning element, said tensioning element adapted to be coupled to the proximal end of the endoscope.

31. A treatment device according to claim 30, wherein:

said channel engaging element is a tube sized to frictionally engage the endoscope.

32. A treatment device according to claim 31, wherein:

said channel engaging element comprises a cylinder defining at least one longitudinal slit.

33. A treatment device according to claim 30, wherein:

said wire or cable element is attached to said endoscope channel engaging element.

34. A treatment device according to claim 30, wherein:

said distal end of said wire or cable element comprises a bead having a first width, and said cap assembly includes a channel lock receiver defining a groove having a second width smaller than said first width.

35. A treatment device according to claim 34, wherein:

said wire or cable element removably engages said channel lock receiver.

36. A treatment device according to claim 30, wherein:

said tensioning element comprises a spring.

37. A treatment device for use with an endoscope or guide member which is used to perform treatment in a body by being operated outside the body, comprising:

a cap assembly which is arranged at the distal end portion of the endoscope or guide member, said cap assembly comprising an end effector and a gear assembly coupled to said end effector, said gear assembly having a first gear element and a second gear element meshing with said first gear element; and

a flexible transmission member having a distal end portion which is capable of being inserted into the body through or adjacent the endoscope or guide member, said distal end portion of said flexible transmission member coupled to said gear assembly, said flexible transmission member being actuated by an operation outside the body.

38. A treatment device according to claim 37, wherein:

said gear assembly causes rotation of said end effector upon actuation of said flexible transmission member.

39. A treatment device according to claim 38, wherein:

said cap assembly includes a mounting element extending away from a front face of the endoscope or guide member and said first gear element and said second gear element are mounted on said mounting element.

40. A treatment device according to claim 39, wherein:

said first gear element includes a first gear, and said second gear element includes a second gear, and said first gear is located further from said endoscope or guide member than said second gear.

41. A treatment device according to claim 40, wherein:

said transmission element is coupled to said first gear element and said end effector is coupled to said second gear element.

42. A treatment device according to claim 41, wherein:

said end effector includes a needle holder arm and a needle.

43. A treatment device according to claim 42, wherein:

said needle holder arm is curved through an angle of approximately ninety degrees.

44. A treatment device according to claim 41, wherein:

said second gear element includes an arm extending from said second gear such that in one position, said arm extends around and over said first gear element.

45. A treatment device according to claim 44, wherein:

said end effector includes a needle holder arm coupled to said arm of said second gear element and a needle connected to said needle holder arm.

46. A treatment device according to claim 39, wherein:

said mounting element includes first and second arms coupled by an arch and said first gear element and said second gear element are respectively mounted between said first and second arms under said arch by first and second pivot pins.

47. A treatment device for use with an endoscope or guide member and with a needle having a tip, said treatment device being used to perform treatment in a body by being operated outside the body, comprising:

a flexible transmission member having a distal end portion which is capable of being inserted into the body through or adjacent the endoscope or guide member;

a cap assembly which is arranged at the distal end face of the endoscope or guide member, said cap assembly including a needle guard member having two arms extending substantially perpendicular to the distal end face of the endoscope or guide member, and a movable needle holder arm coupled to said flexible transmission member, said movable needle holder arm being adapted to hold the needle, wherein in a first position, said needle holder arm holds the needle so that the tip of the needle is located between said two arms and spaced from the distal end face of the endoscope or guide member, and in a second position, said needle holder arm extends between said two arms and holds the needle so that the tip of the needle is exposed.

48. A treatment device according to claim 47, wherein:

said two arms are coupled by an arch, and in said first position said tip of the needle is located under said arch.

49. A treatment device according to claim 48, wherein:

said two arms are further coupled by a cross-member spaced from said arch, and in said first position said tip of the needle is located between the cross-member and said arch.

50. A treatment device according to claim 47, wherein:

each of said two arms defines at least one pivot pin hole for receiving a pivot pin about which said movable needle holder arm pivots from said first position to said second position.

51. A treatment device according to claim 50, wherein:

said cap assembly further comprises a gear assembly held by and between said two arms and coupled to said flexible transmission member and to said movable needle holder arm, said gear assembly causing said pivoting of said movable needle holder arm from said first position to said second position.

52. A treatment device according to claim 51, wherein:

said cap assembly further comprises a ring from which said needle guard member extends.

53. A treatment device according to claim 52, wherein:

said flexible transmission member includes a push wire or cable coupled to said gear assembly and a coil defining a lumen through which said push wire or cable extends, said coil attached to said ring element.

54. A treatment device for use with an endoscope or guide member and with a needle having a tip, said treatment device being used to perform treatment in a body by being operated outside the body, comprising:

a cap assembly which is arranged at the distal end face of the endoscope or guide member, said cap assembly including a tissue guard member extending substantially perpendicular to the distal end face of the endoscope or guide member, said tissue guard member having an inner surface, an outer surface, and side surfaces joining said inner surface and said outer surface, and a top surface, said inner surface curved along a circle of a first diameter and extending at least approximately 180 degrees around that circle and located above and around a channel of the endoscope or guide member, said outer surface being curved along a circle of a second diameter larger than said first diameter, said top surface angled relative to said distal end face.

55. A treatment device according to claim 54, wherein:

said cap assembly comprises a ring from which said tissue guard member extends, said ring having a diameter substantially equal to said second diameter.

56. A treatment device according to claim 55, wherein:

said outer surface circumscribes approximately 50 degrees of said ring.

57. A treatment device according to claim 55, wherein:

said top wall is angled at approximately 45 degrees relative to said ring.

58. A treatment device according to claim 55, wherein:

a portion of said tissue guard member extends approximately 9mm past said ring.

59. A treatment device according to claim 54, wherein:

said first diameter is approximately between 4mm and 5mm in size.

60. A treatment device for use with an endoscope or guide member having a channel with a longitudinal axis and distal end face and for use with a needle having a tip, said treatment device being used to perform treatment in a body by being operated outside the body, comprising:

a flexible transmission member having a distal end portion which is capable of being inserted into the body through or adjacent the endoscope or guide member;

a cap assembly arranged at the distal end face of the endoscope or guide member, said cap assembly including a rotatable needle holder arm adapted to hold the needle and coupled to said flexible transmission member, said rotatable needle holder arm rotating in response to movement of said flexible transmission member in a plane which bisects the distal end face of the endoscope or guide member wherein in a first position, said needle holder arm holds the needle so that the tip of the needle is not parallel the longitudinal axis of the channel, and in a second position, said needle holder arm holds the needle so that the tip of the needle is parallel the longitudinal axis of the channel.

61. A treatment device according to claim 60, wherein:

said needle holder arm holds the needle so that the tip of the needle is coaxial with the longitudinal axis of the channel.

62. A treatment device according to claim 61, further comprising:

said needle having a tip.

63. A suture dispenser comprising:

a dispenser body housing having an outer wall with a first orifice and an inner wall spaced from said outer wall with a second orifice aligned with said first orifice; and

a needle, a suture attached to said needle, a spool around which said suture is wound, and a needle guard all housed in said dispenser body housing, said needle guard held in place between said outer wall and said inner wall and defining a cavity for receiving said needle, said needle held frictionally in place in said needle guard cavity and extending through said second orifice of said second wall and having a tip arranged behind said first orifice.

64. A suture dispenser according to claim 63, further comprising:

a removable needle shield, wherein said outer wall is arranged with a third orifice spaced from said first orifice and said second orifice and said removable needle shield is located

between said needle guard and said outer wall and includes a grippable portion which extends through said third orifice.

65. A suture dispenser according to claim 64, wherein:

said dispenser body includes an intermediate wall between said outer wall and said inner wall, and said needle guard is located between said intermediate wall and said inner wall, and said removable needle shield is located between said intermediate wall and said outer wall, said intermediate wall and said outer wall forming a groove therebetween in which said removable needle shield can slide.

66. A suture dispenser according to claim 65, wherein:

said inner wall includes a first portion substantially parallel to said outer wall at said first and second orifices and a second portion angled relative to said first portion and intersecting said outer wall.

67. A suture dispenser according to claim 66, wherein:

said second portion of said inner wall blocks movement of said needle guard.

68. A suture dispenser according to claim 63, wherein:

said dispenser body housing includes an upper body and a lower body, at least one of said upper body and said lower body including ribs on which said spool rests.

69. A suture dispenser according to claim 63, wherein:

said dispenser body housing includes an upper body and a lower body each including at least one engaging element which engages a reciprocal engaging element on the other.

70. A suture dispenser according to claim 65, wherein:

said needle guard comprises first and second flanges located between said intermediate wall and said inner wall,

71. A suture dispenser according to claim 64, wherein:

said needle guard comprises a cylindrical body located in said second orifice.

72. A method of suturing tissue of a mammal utilizing the treatment device or treatment system set forth in any of claims 1- 62, comprising:

causing a needle of or coupled to the treatment device or treatment system and having a suture connected thereto to puncture the tissue such that the suture extends into the tissue.

73. A method of suturing tissue of a mammal using an endoscopic suturing system, comprising the follow steps:

(a) inserting a guide tube and/or endoscope into a body with a suturing device coupled to the endoscope and or guide tube;

(b) opening a needle arm of the suturing device having a removable needle;

(c) pushing the needle against tissue at a desired suture site;

(d) closing the needle arm of the suturing device;

(e) piercing the tissue with the needle;

(f) recovering the needle by using a needle capture device;

(g) removing the needle from the tissue;

(h) opening the needle arm to remove it from tissue;

(i) closing the needle arm; and

(j) removing the suturing device from the body.

74. A method according to claim 73, further comprising:

after step (b) and before step (c), engaging a tissue adjacent a desired suture site using a tissue grasper; and

after step (h) and before step (i), releasing the tissue from the tissue grasper.

75. A method according to claim 73, further comprising:

(k) after step (i) and before step (j), inserting the needle into the needle arm endoscopically using the needle capture device; and

repeating steps (b) through (i) and (k) as needed.

76. A method of suturing tissue of a mammal using an endoscopic suturing system, comprising the follow steps:

- (1) inserting a guide tube into a body;
- (2) inserting a suturing device coupled to the endoscope into the guide tube and inserting the suturing device into the body;
- (3) opening a needle holding arm of the suturing device having a removable needle clip;
- (4) engaging a tissue adjacent a desired suture site using a tissue grasper;
- (5) pushing the needle clip against tissue at a desired suture site;
- (6) closing the needle holding arm of the suturing device;
- (7) piercing the tissue with the needle clip;
- (8) grasping the needle clip tip using a needle capture device;
- (9) opening the needle holding arm to remove it from tissue;
- (10) releasing the needle clip from the needle capture device;
- (11) releasing the tissue from the tissue grasper;
- (12) closing the needle holding arm; and
- (13) removing the suturing device from the body.

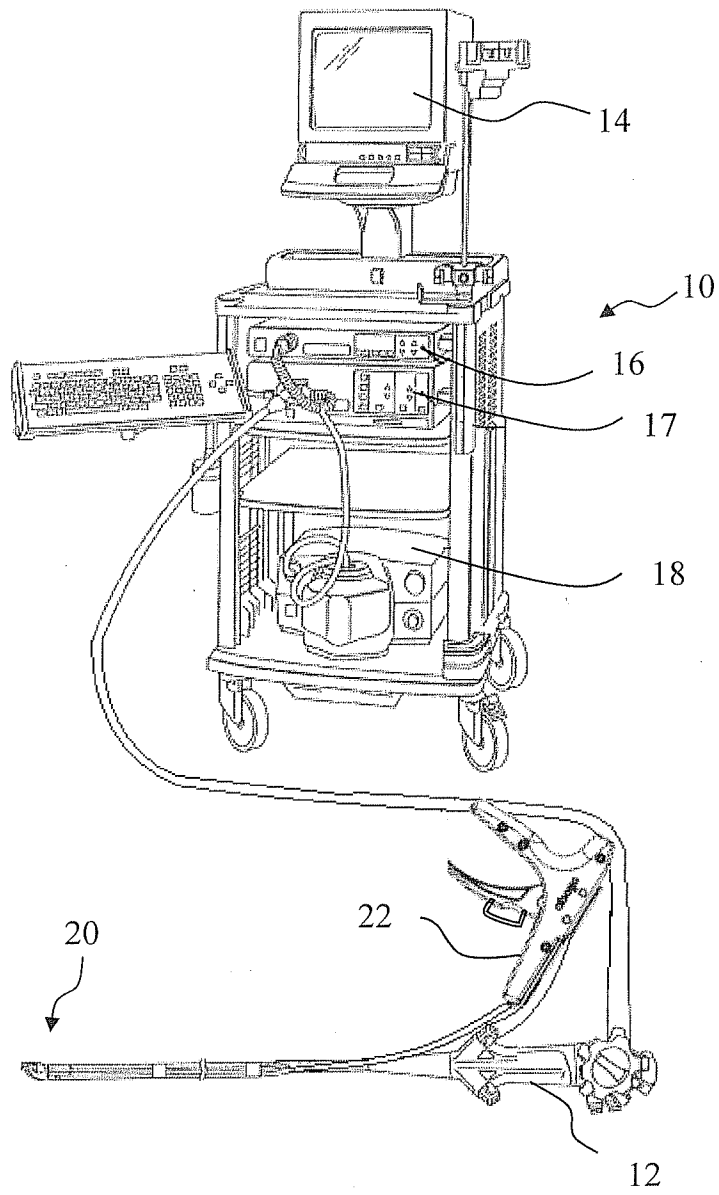

FIG. 1

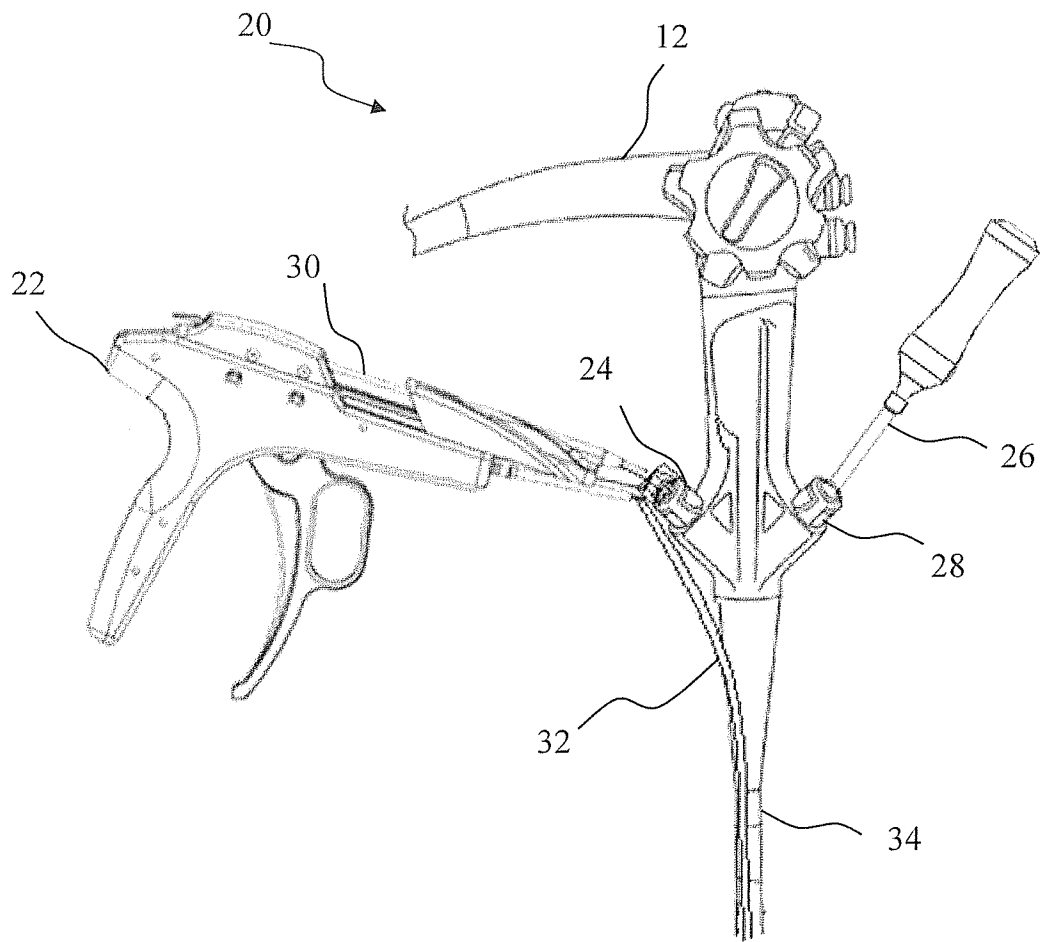

FIG. 2

FIG. 3

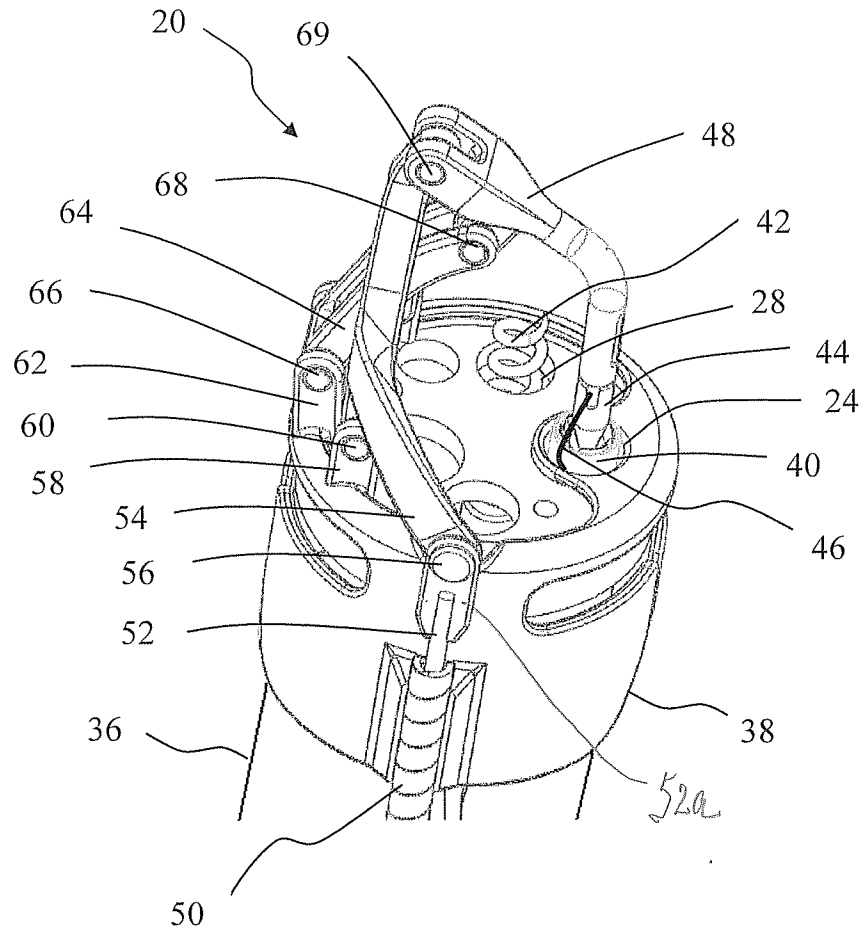
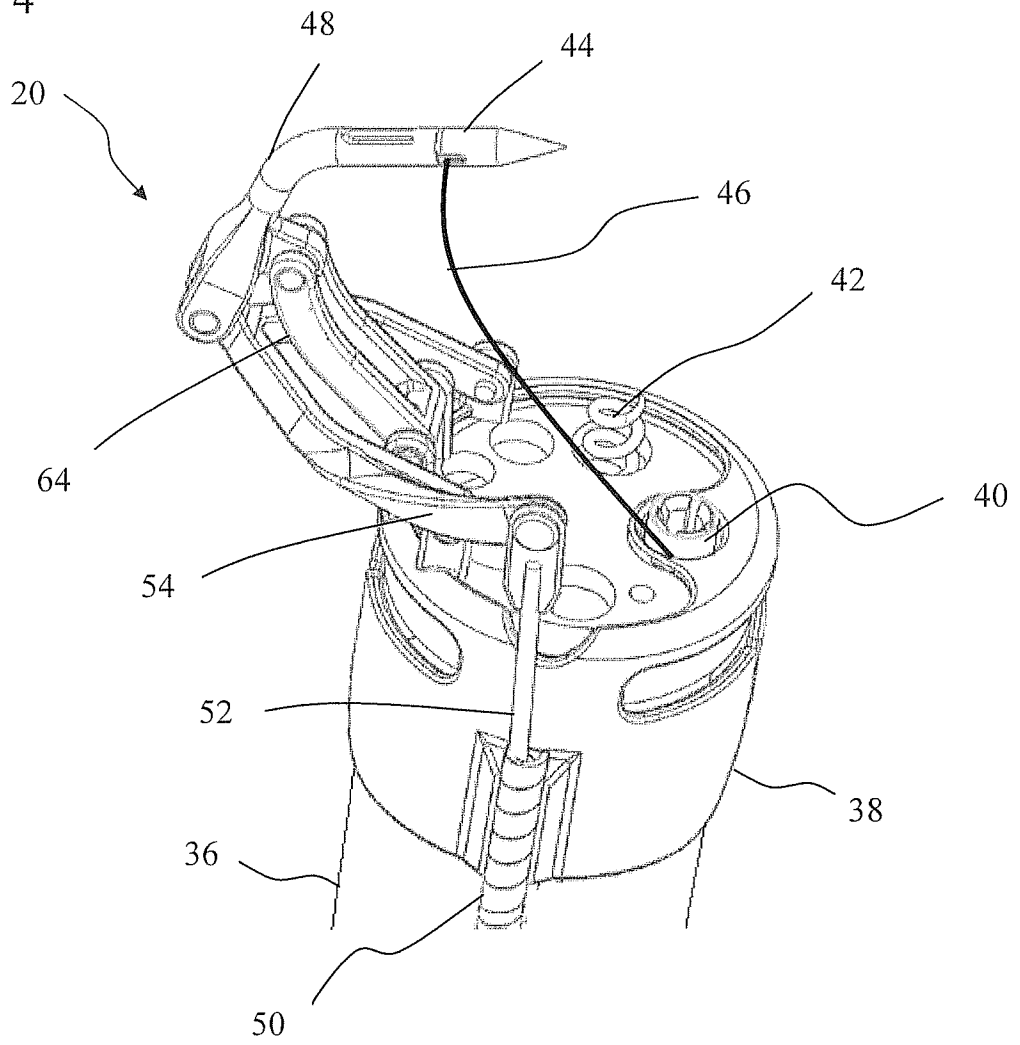

FIG. 4



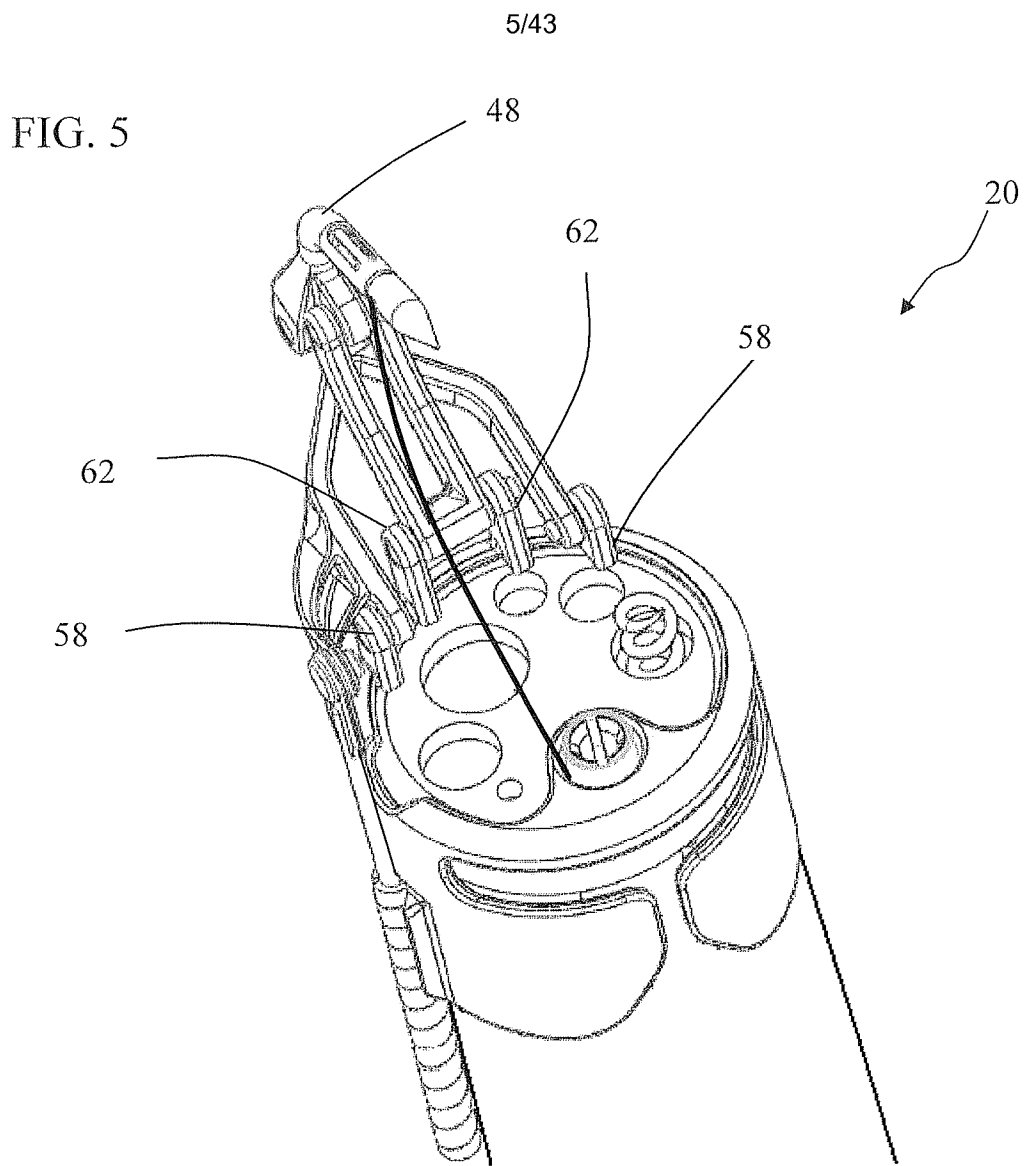

FIG. 6

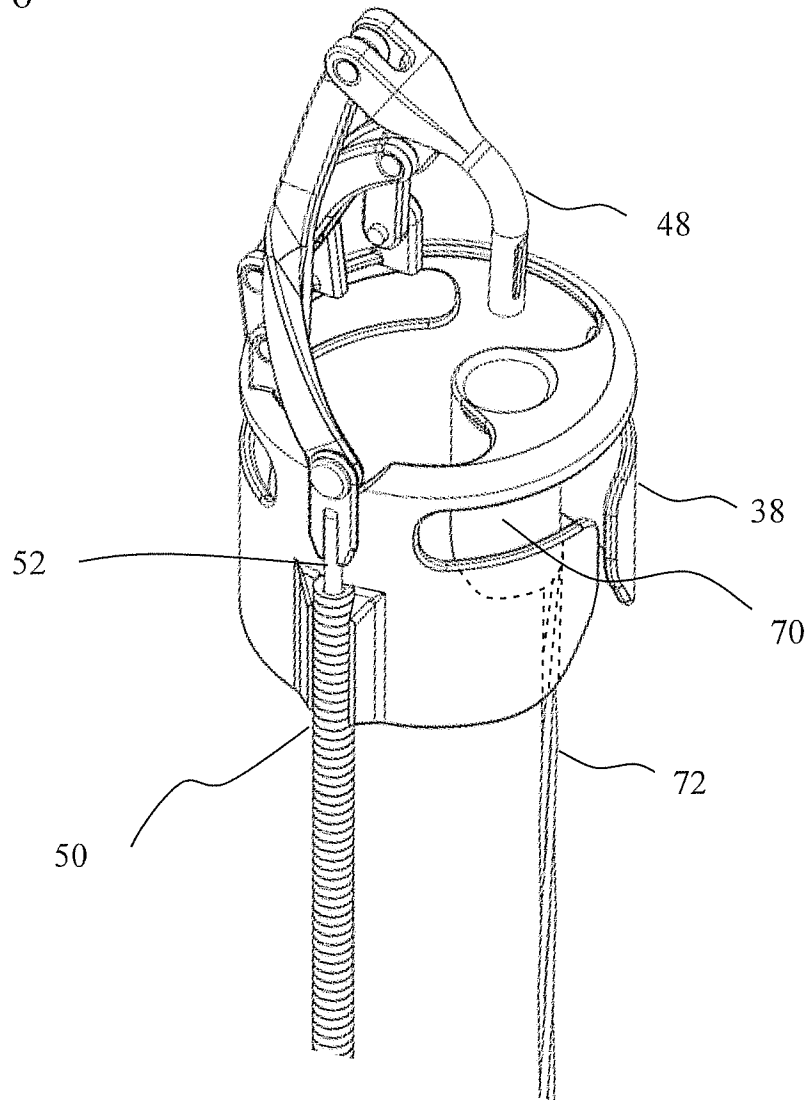

FIG. 7

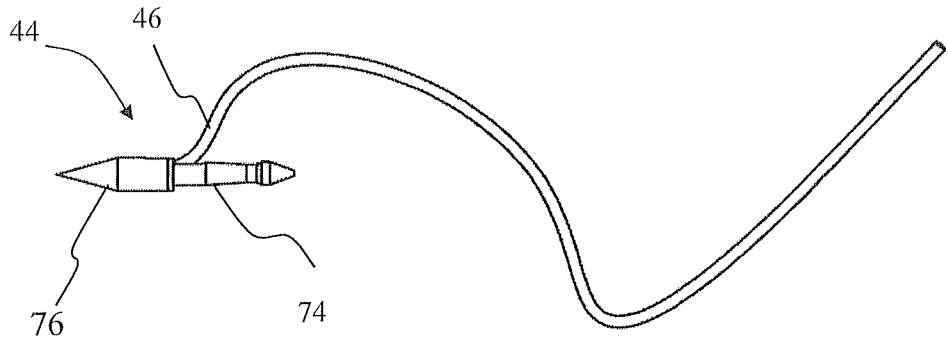

FIG. 8

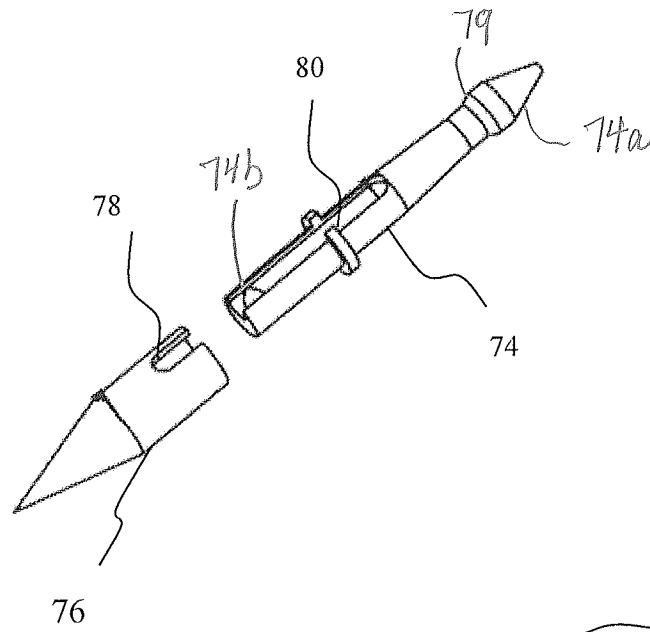

FIG. 9

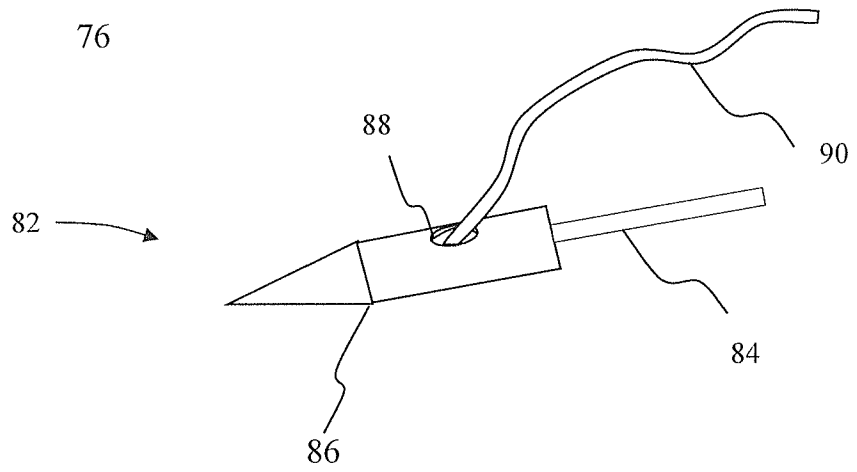

FIG. 10

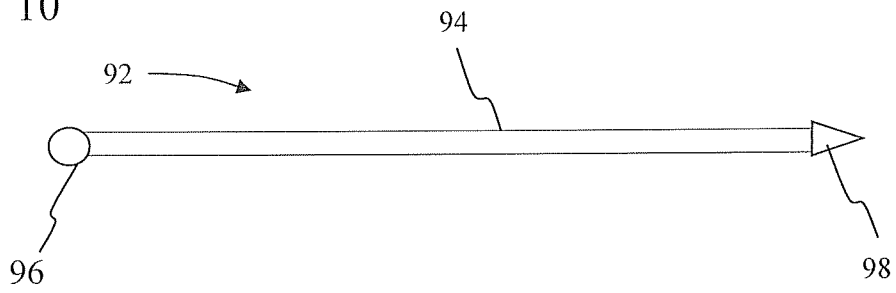

FIG. 11

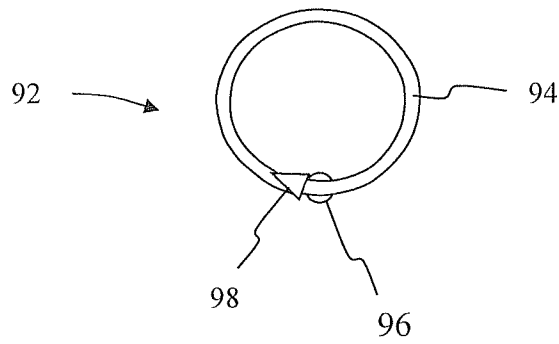

FIG. 12

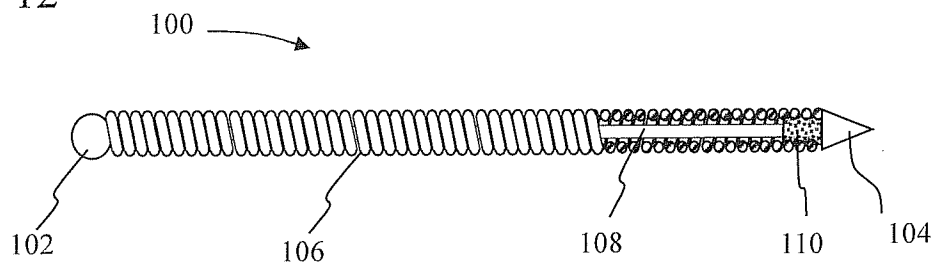

FIG. 13

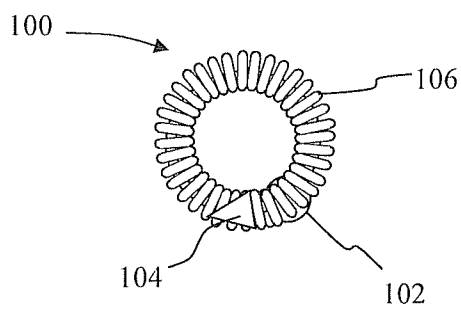

FIG. 13A

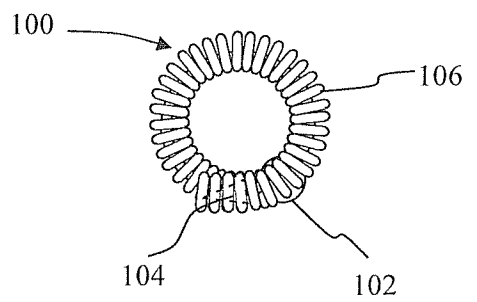

FIG. 14

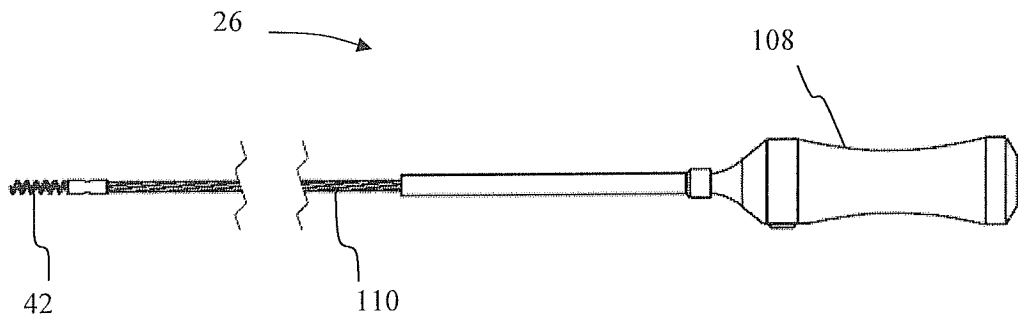

FIG. 15

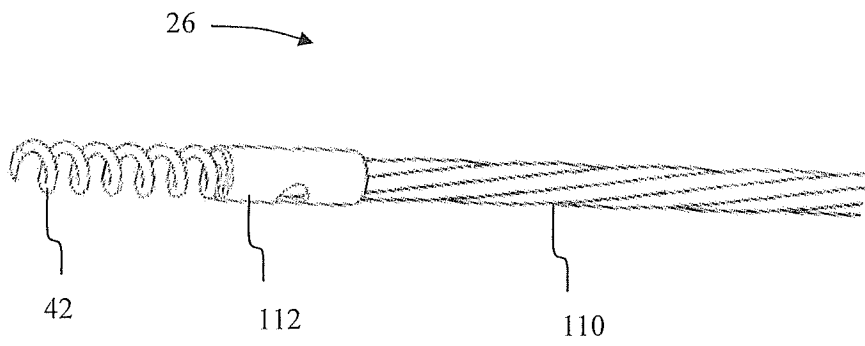

FIG. 16

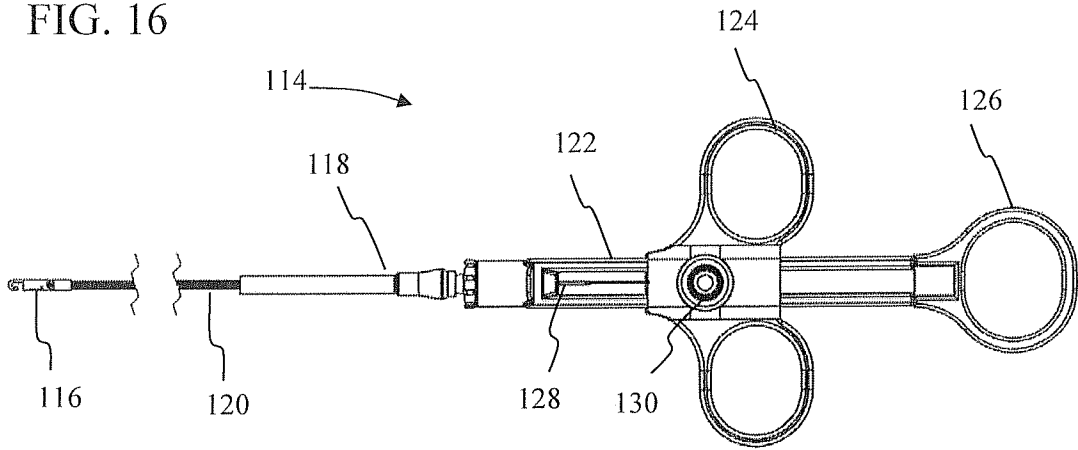

FIG. 17

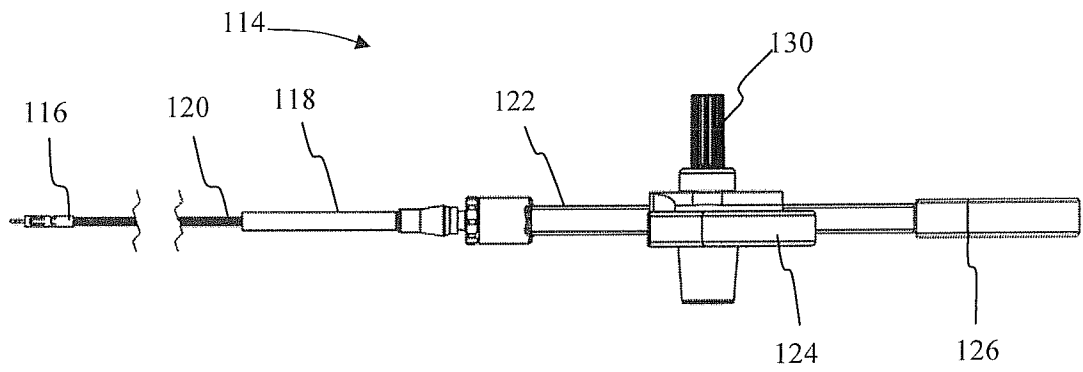

FIG. 18

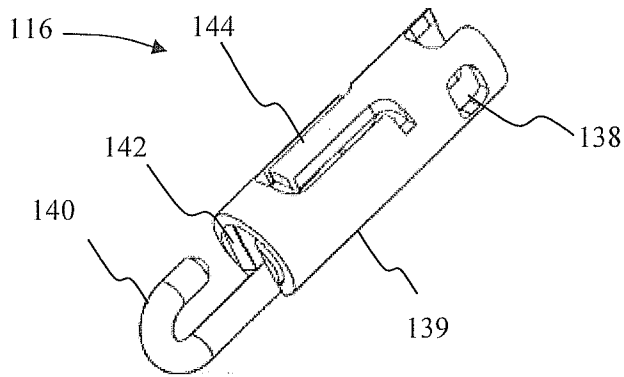
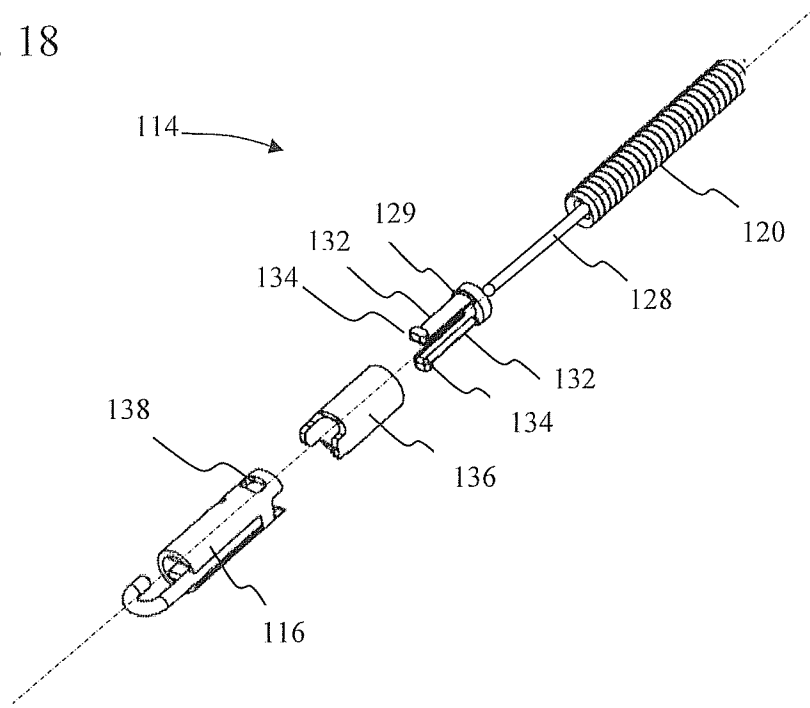

FIG. 19

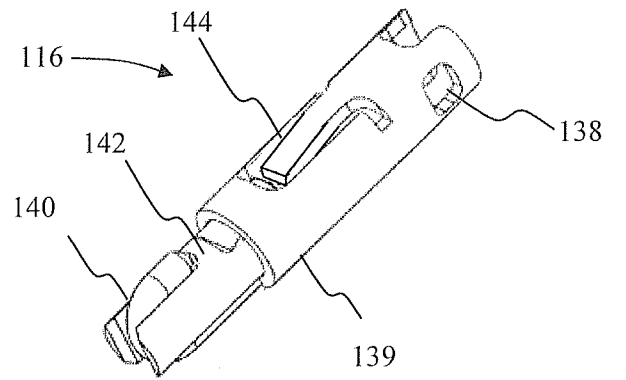

FIG. 20

12/43

FIG. 21

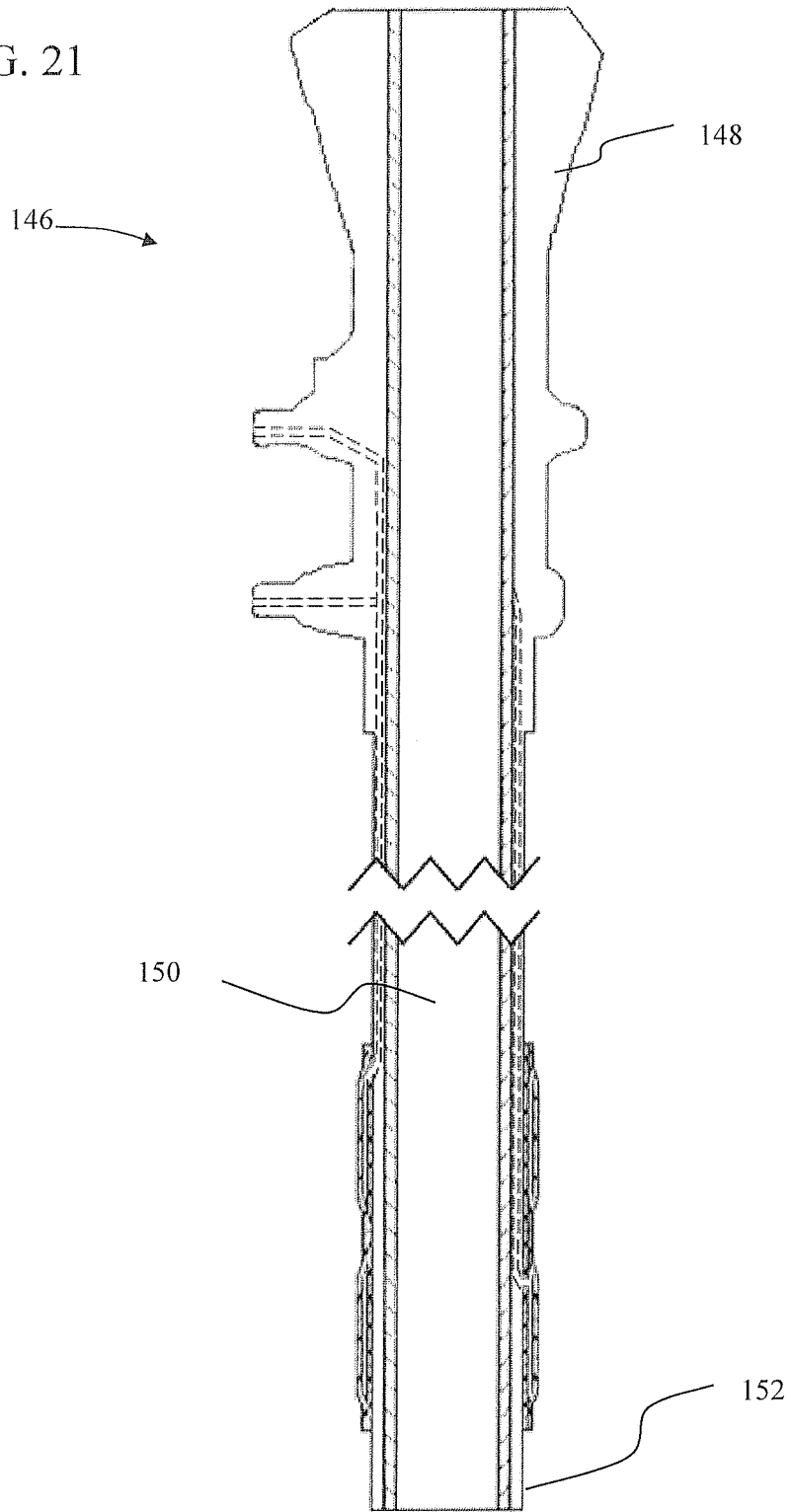

FIG. 22

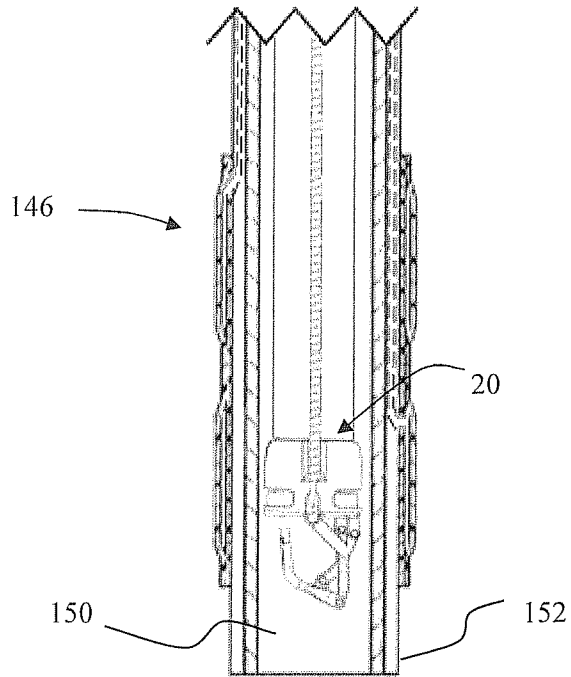

FIG. 23

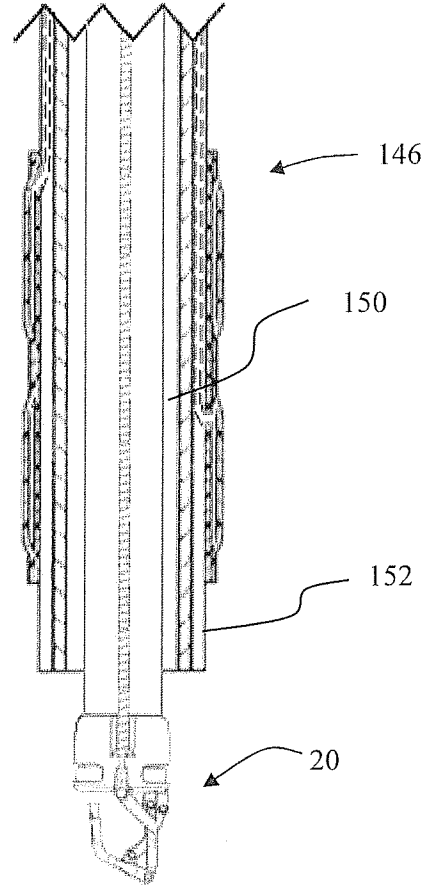

FIG. 24

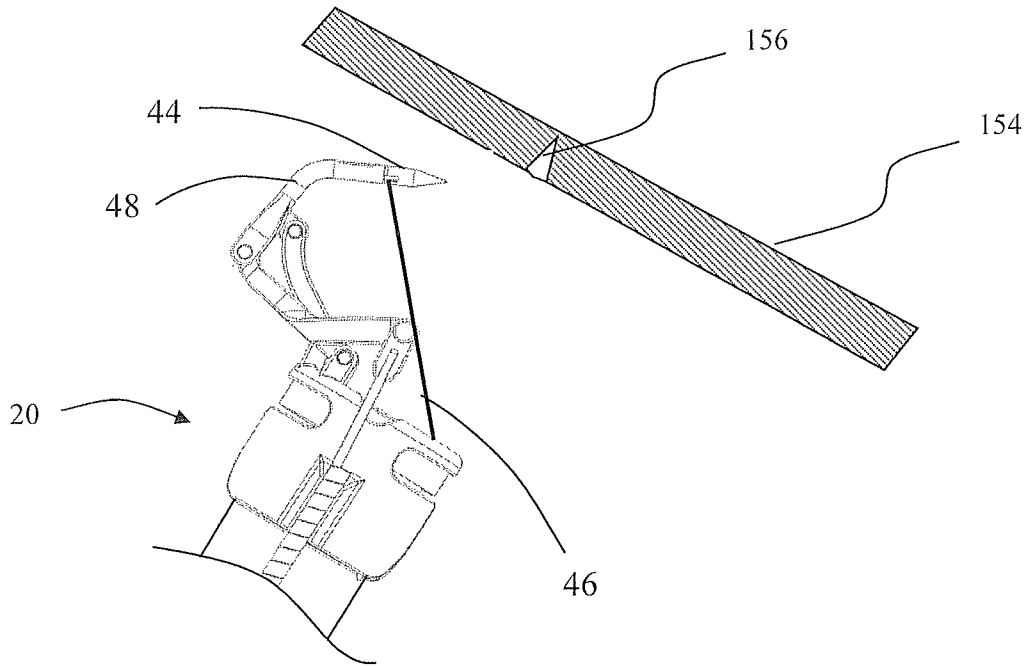

FIG. 25

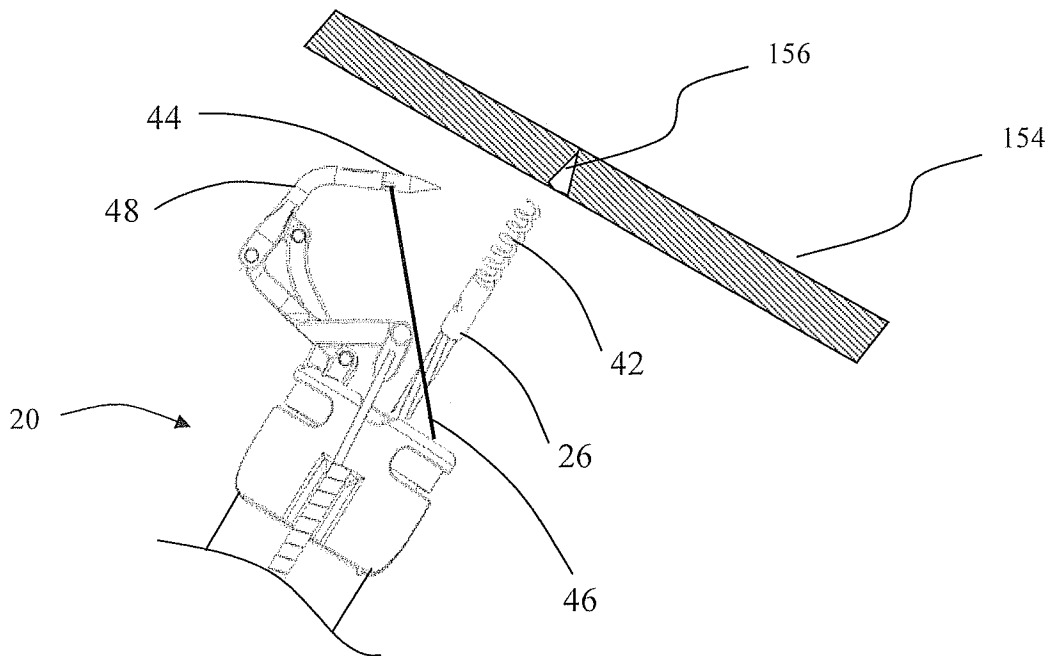

FIG. 26

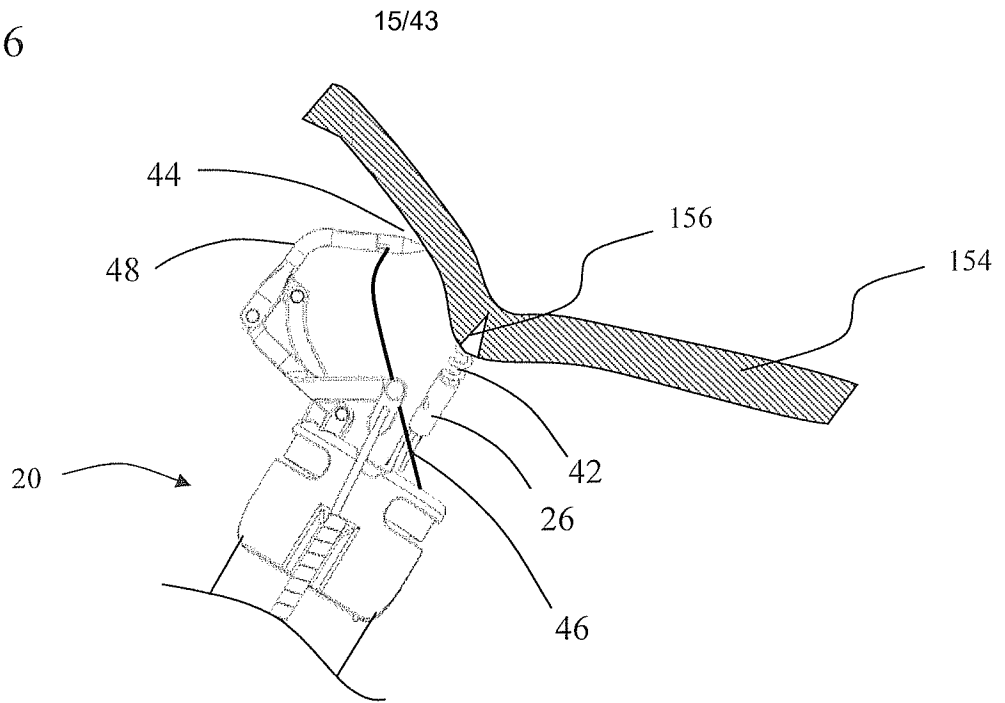

FIG. 27

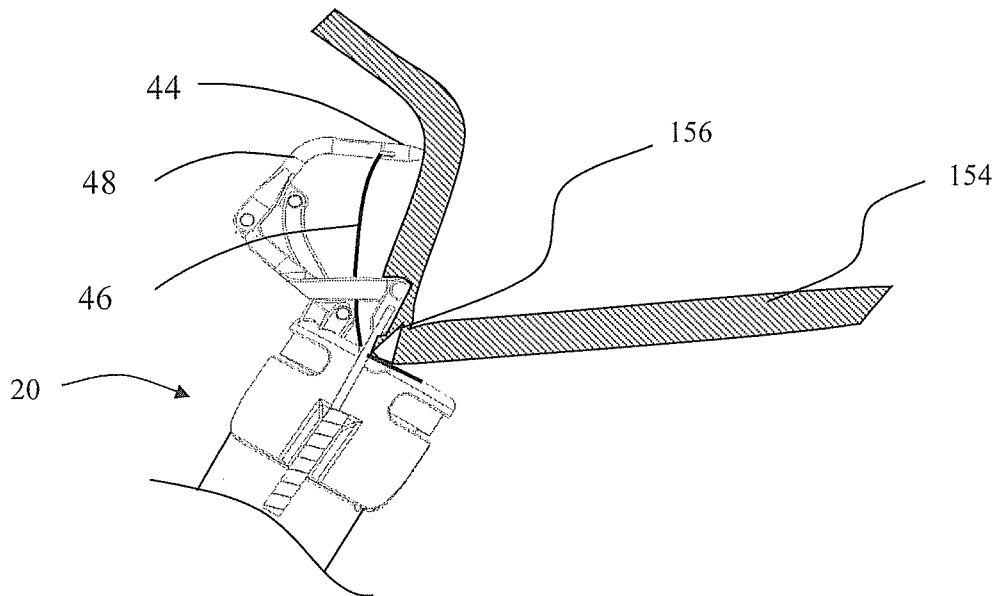

FIG. 28

16/43

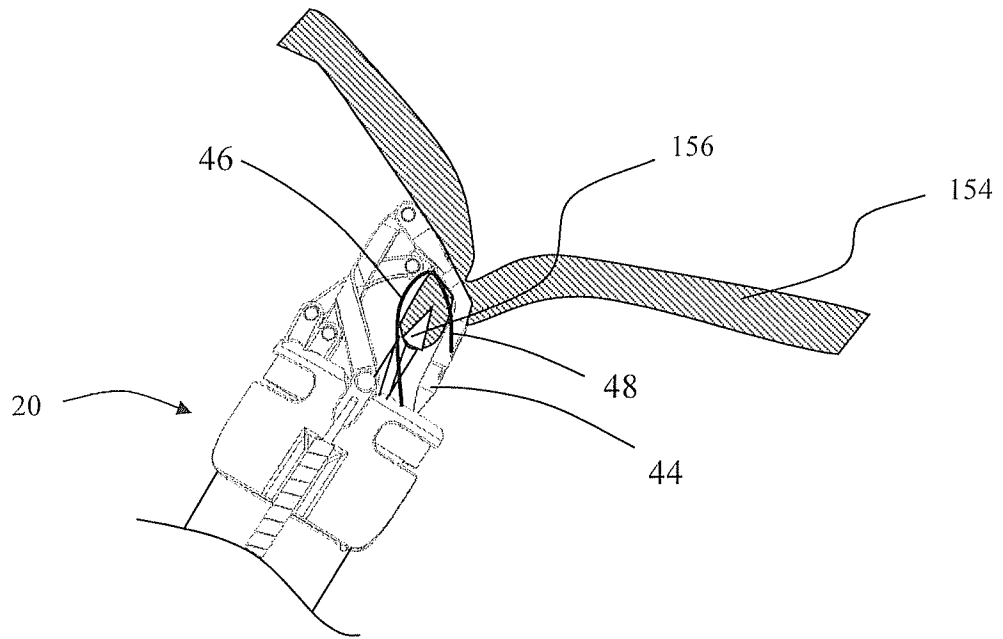

FIG. 29

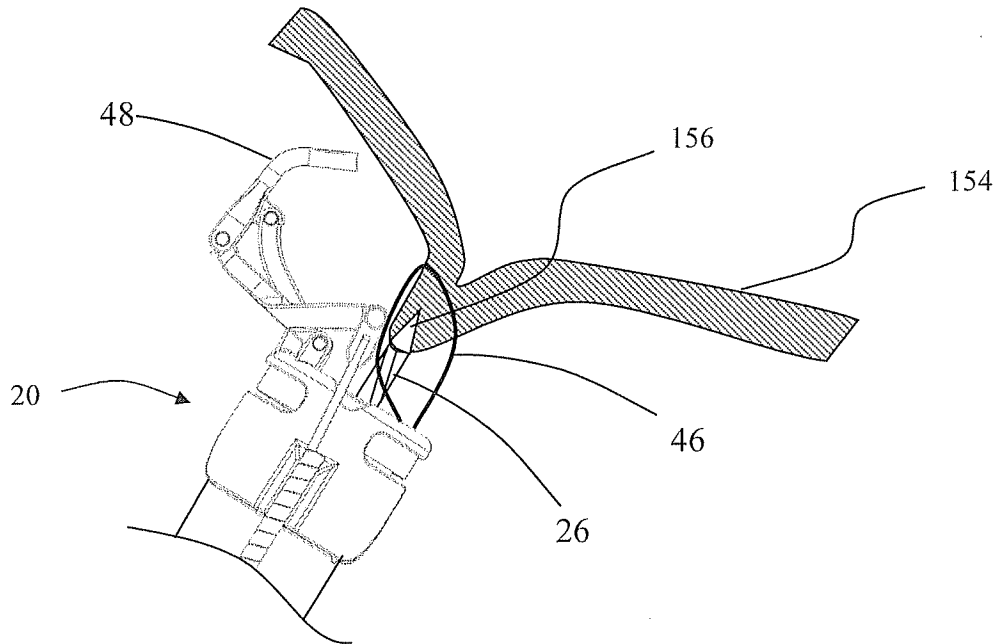

FIG. 30

17/43

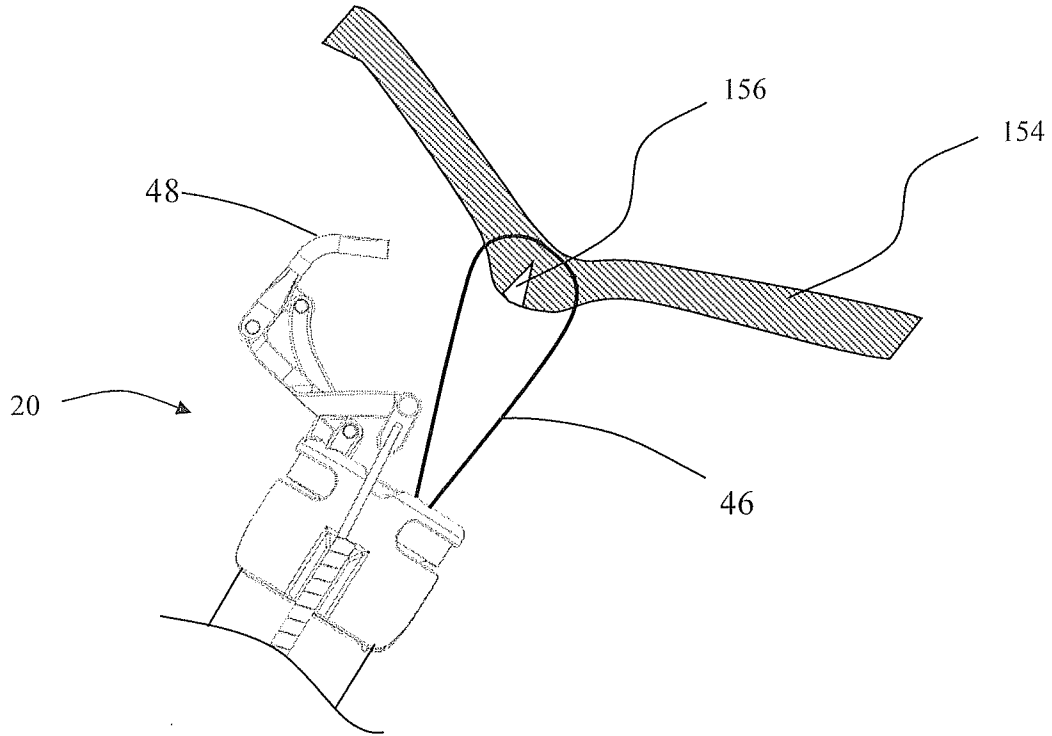

FIG. 31

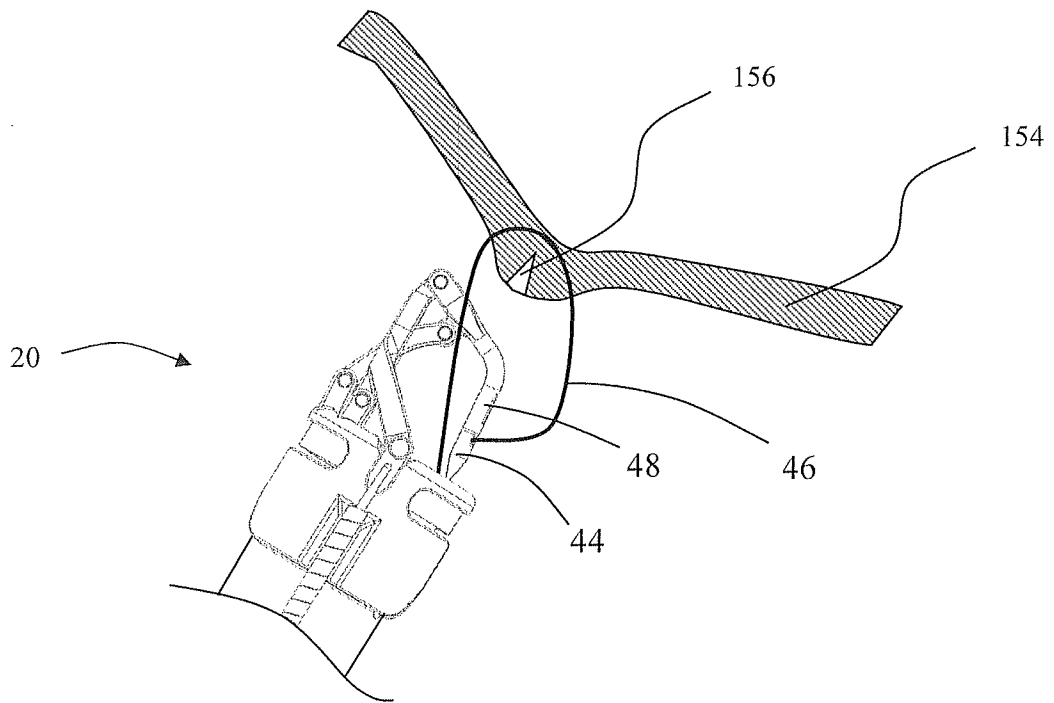

FIG. 32

18/43

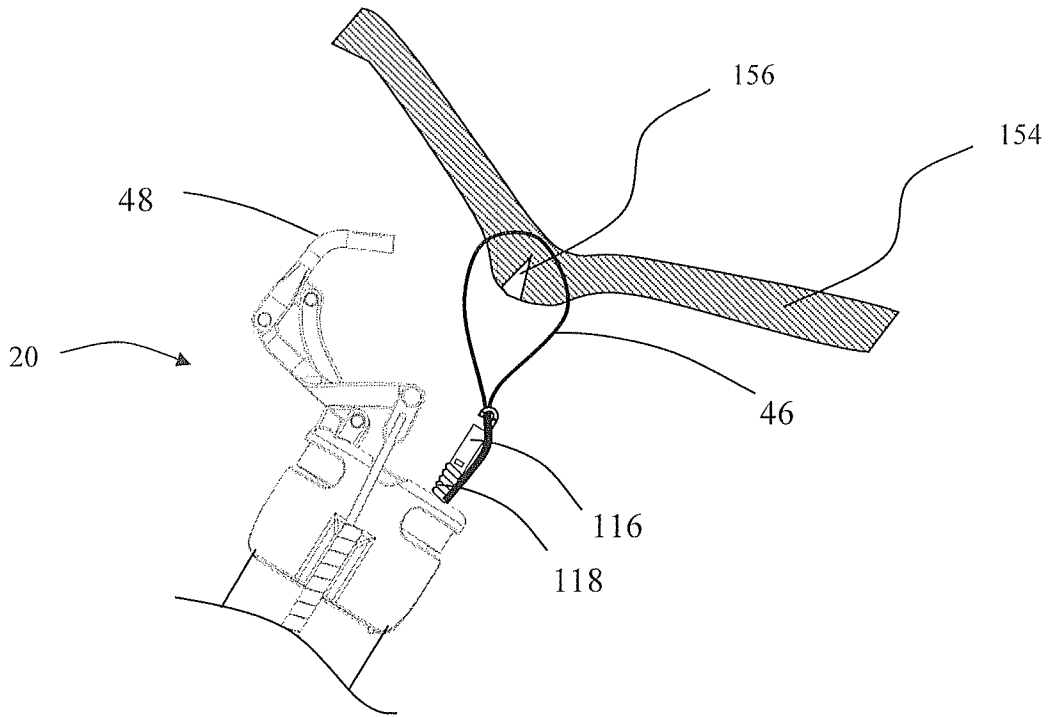

FIG. 33

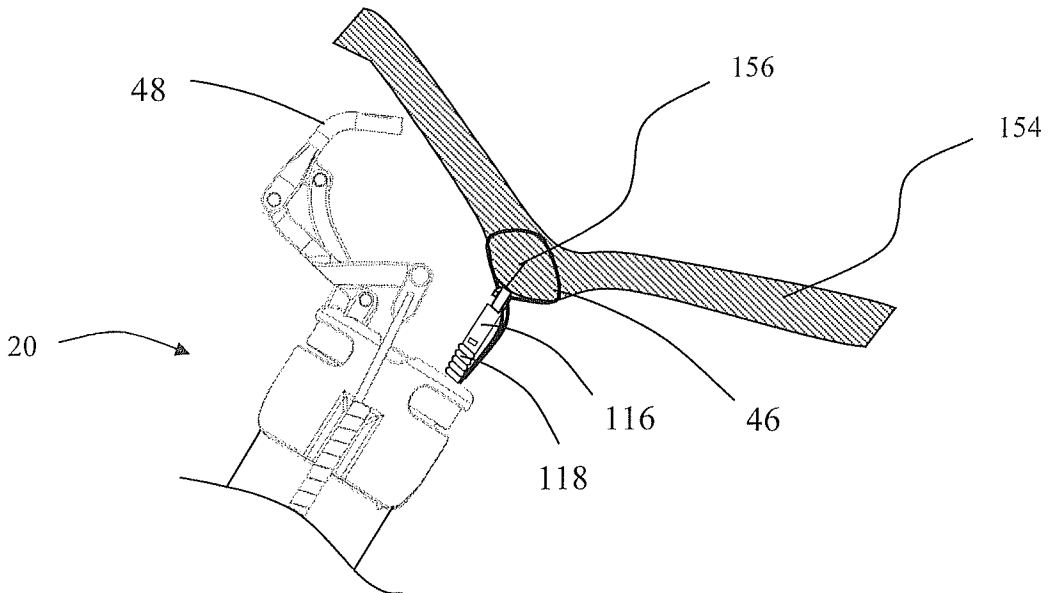

FIG. 34

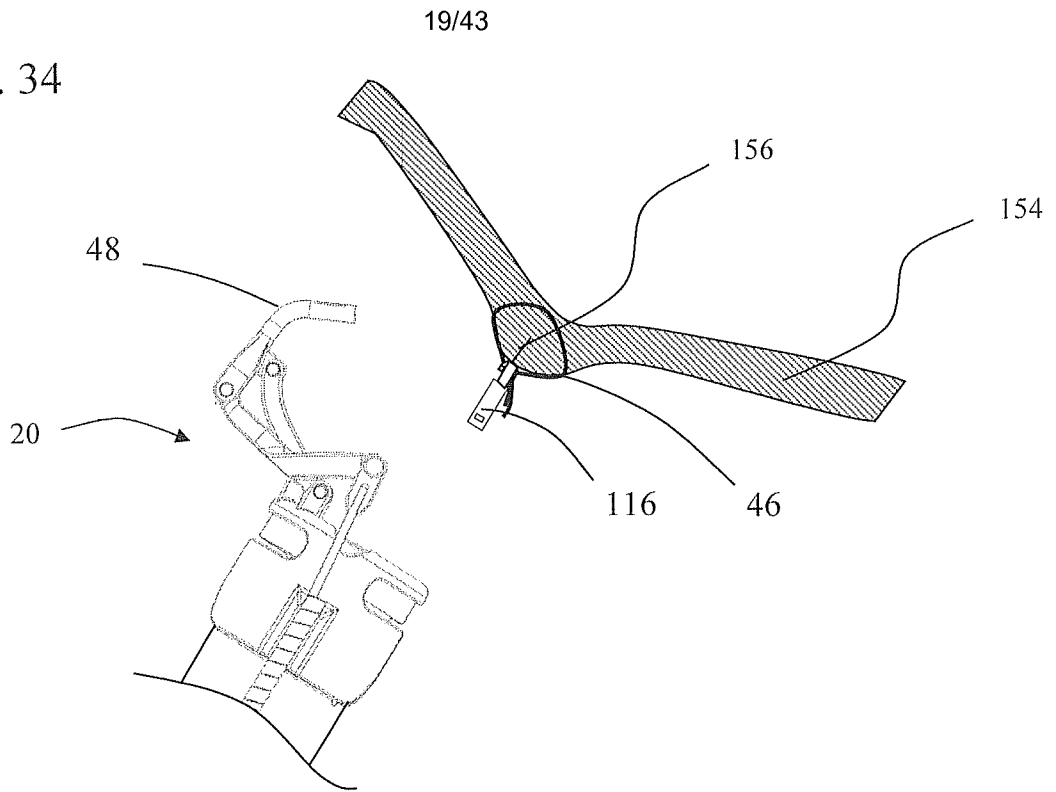

FIG. 35

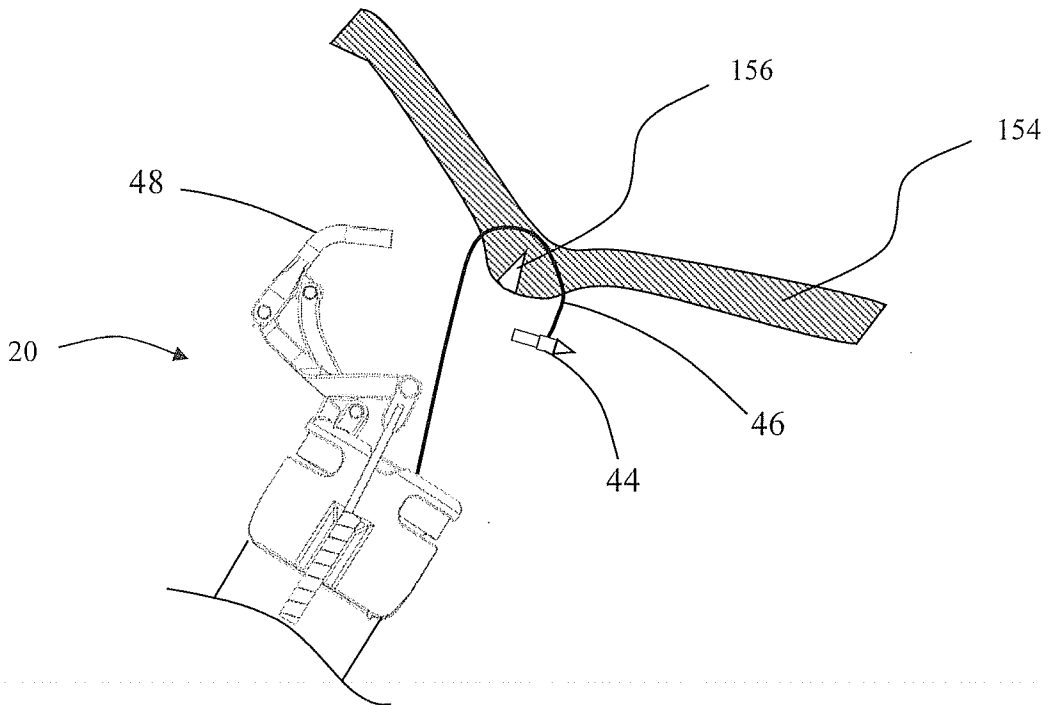

FIG. 36

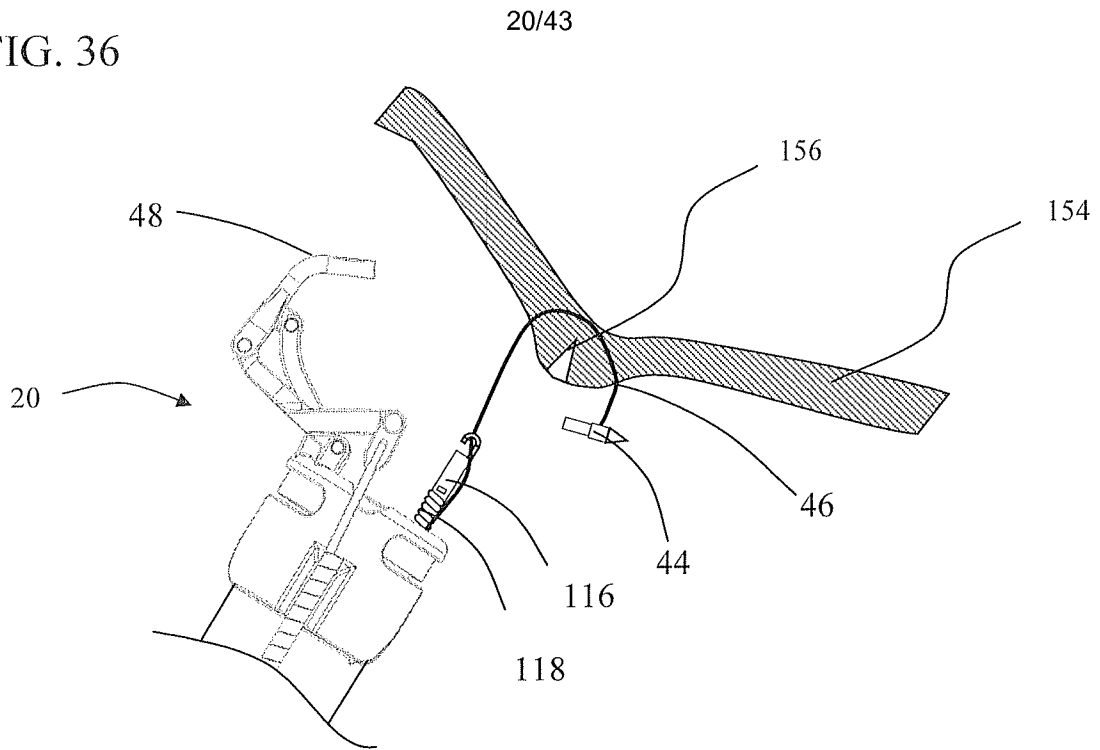

FIG. 37

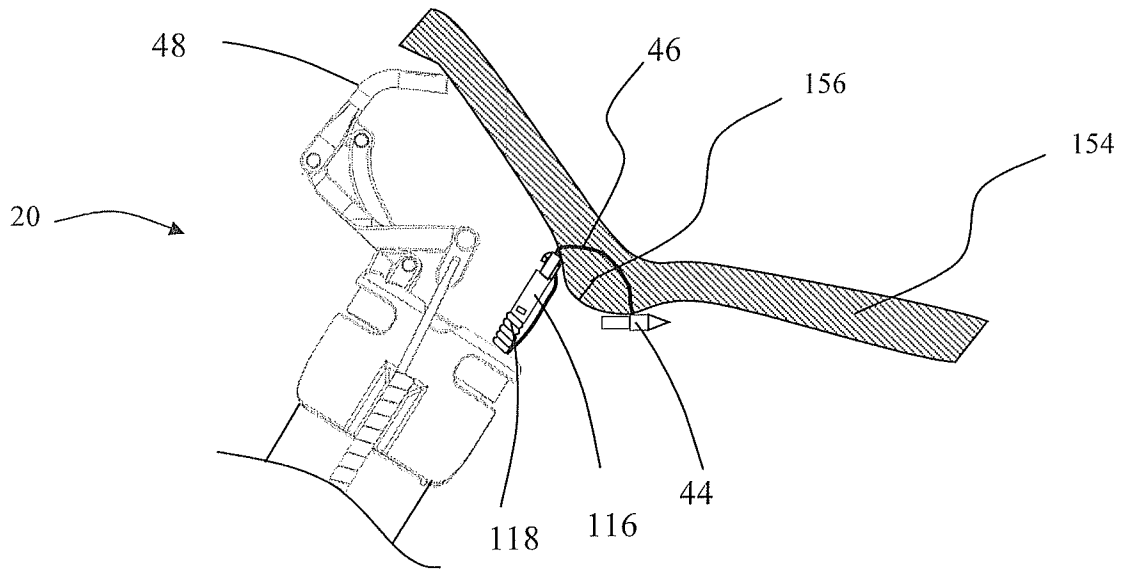

FIG. 38

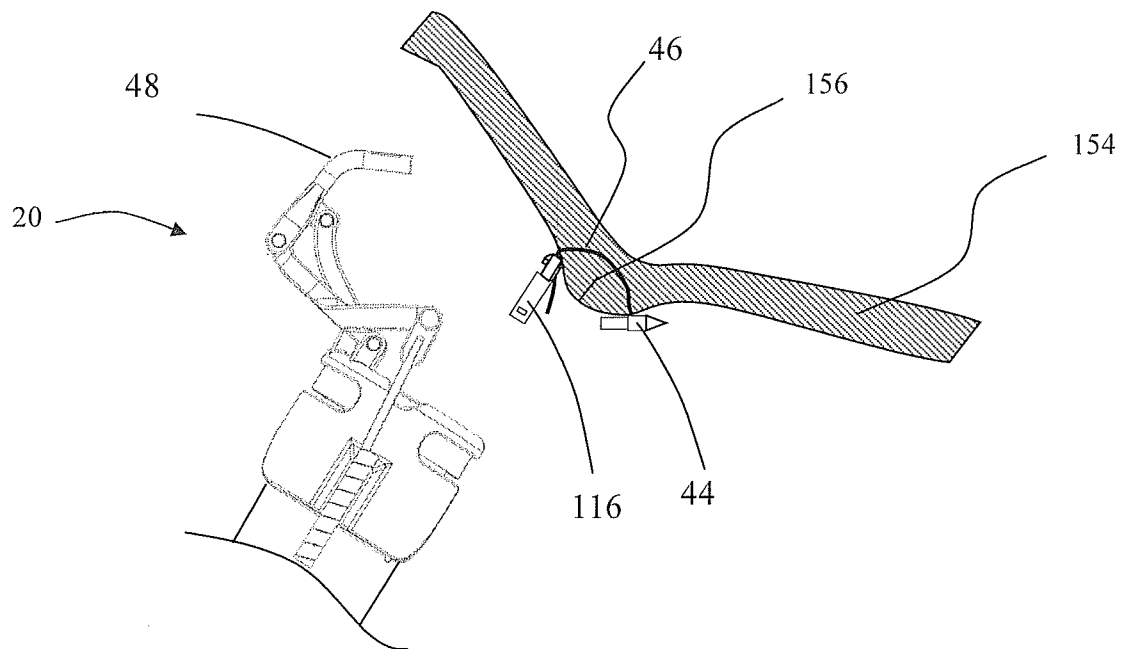

FIG. 39

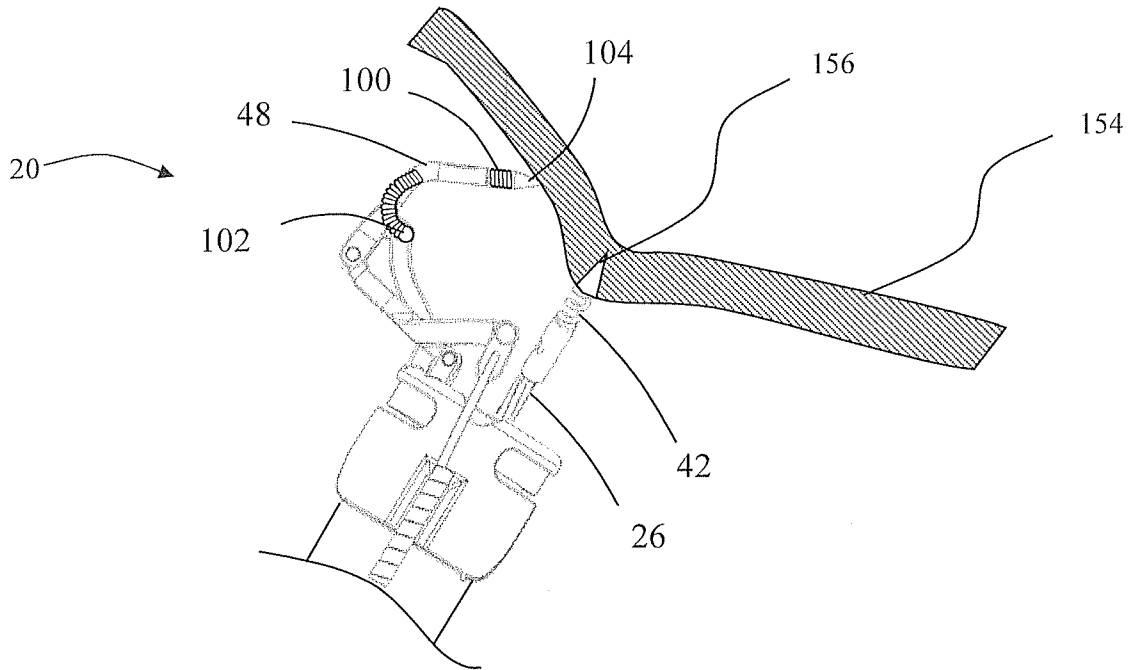

FIG. 40

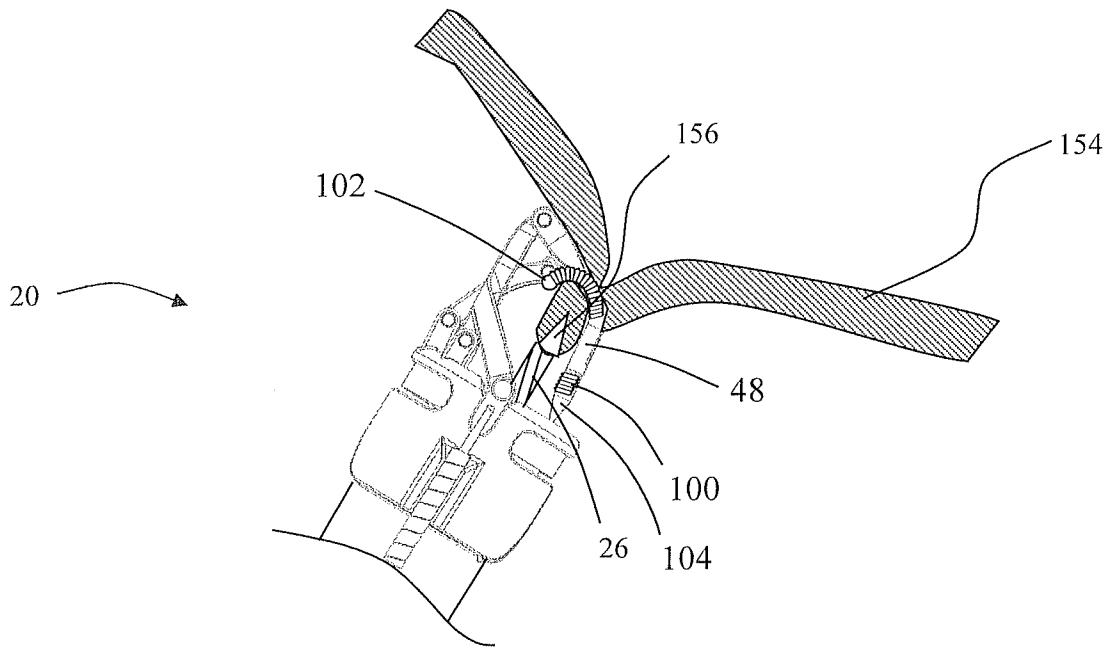

FIG. 41

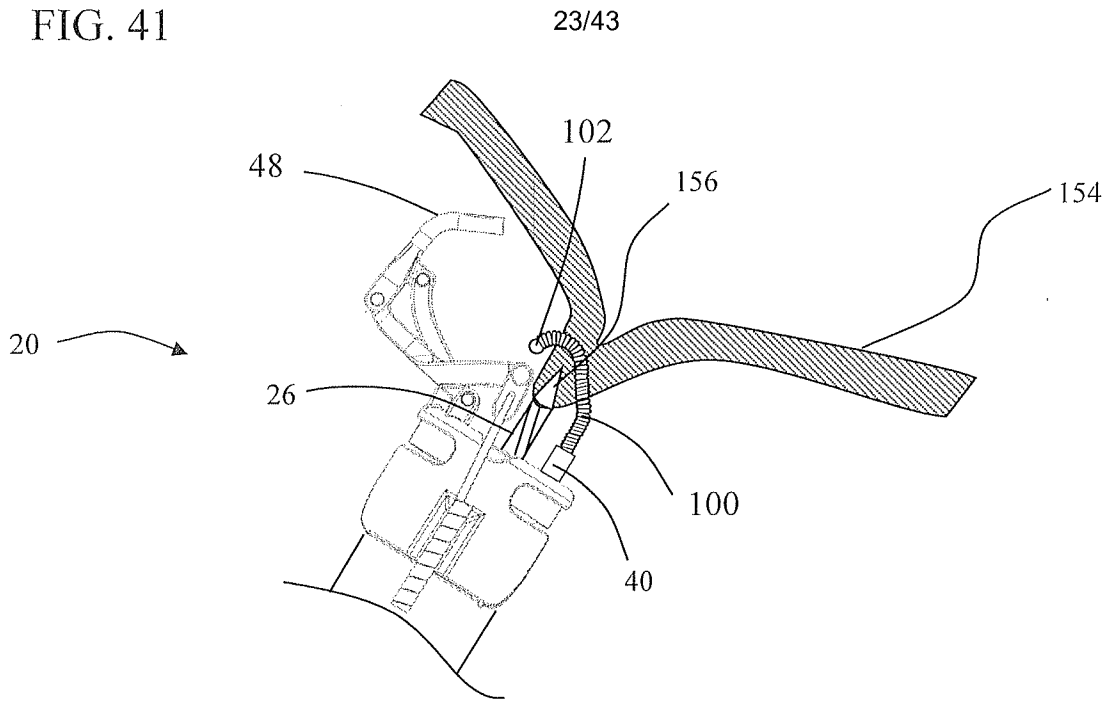
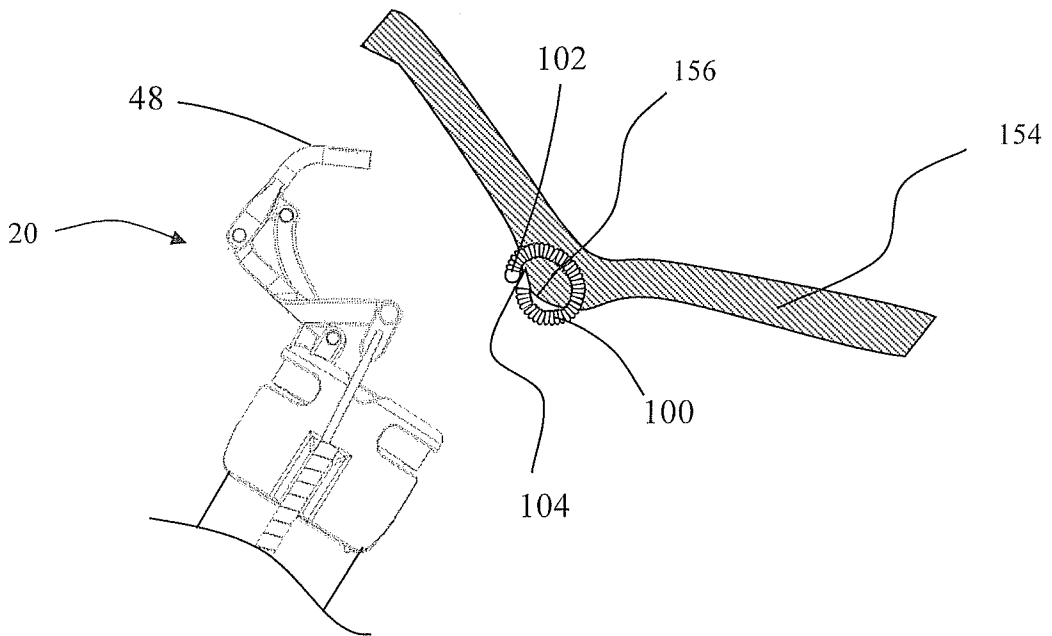

FIG. 42



24/43

FIG. 43

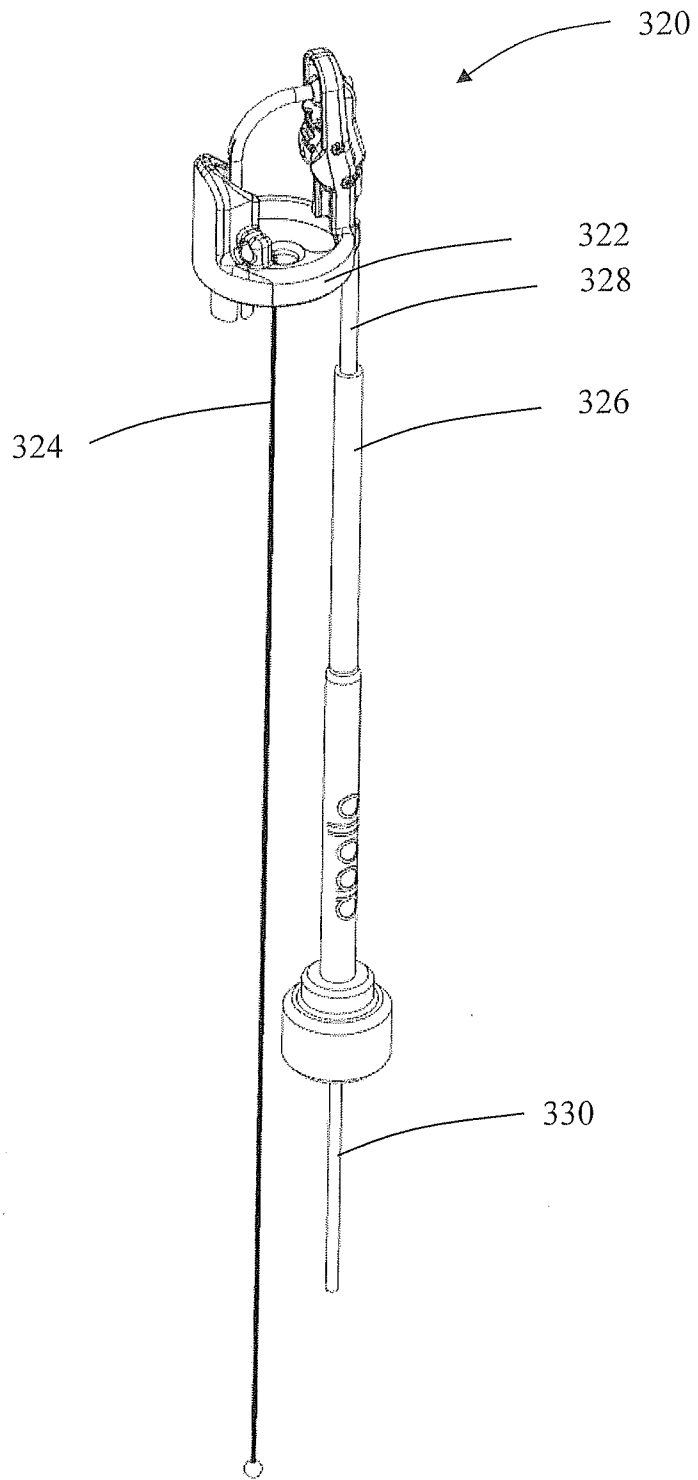

FIG. 44

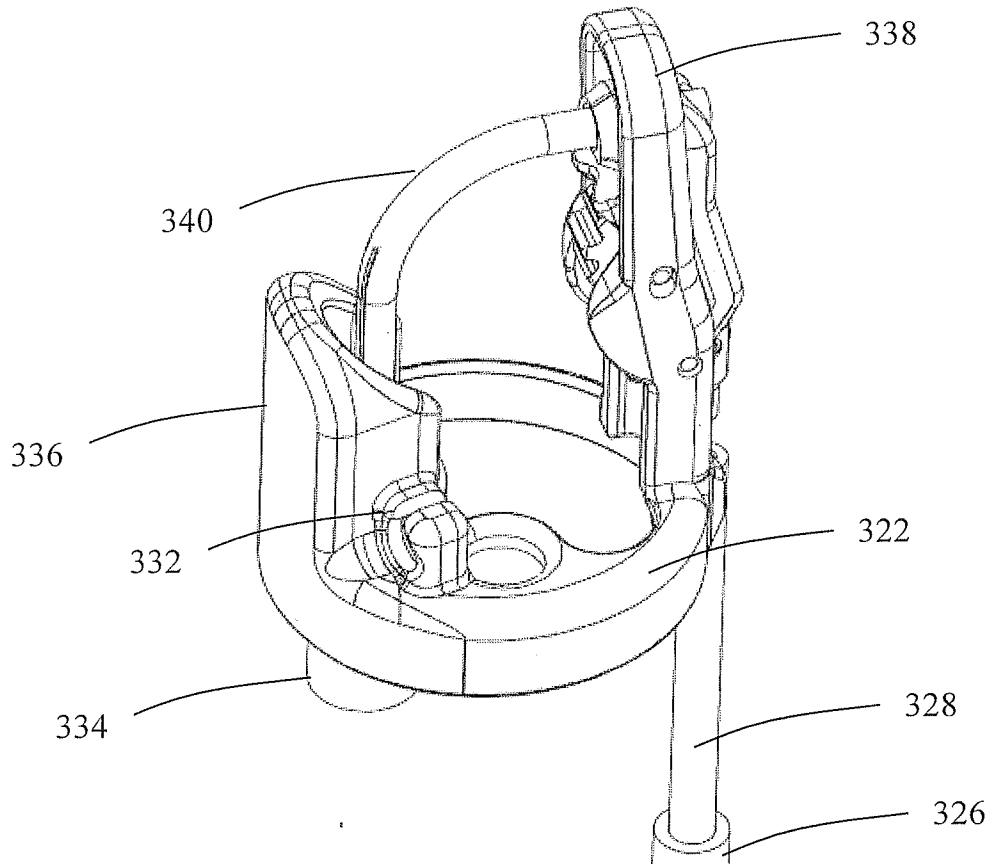
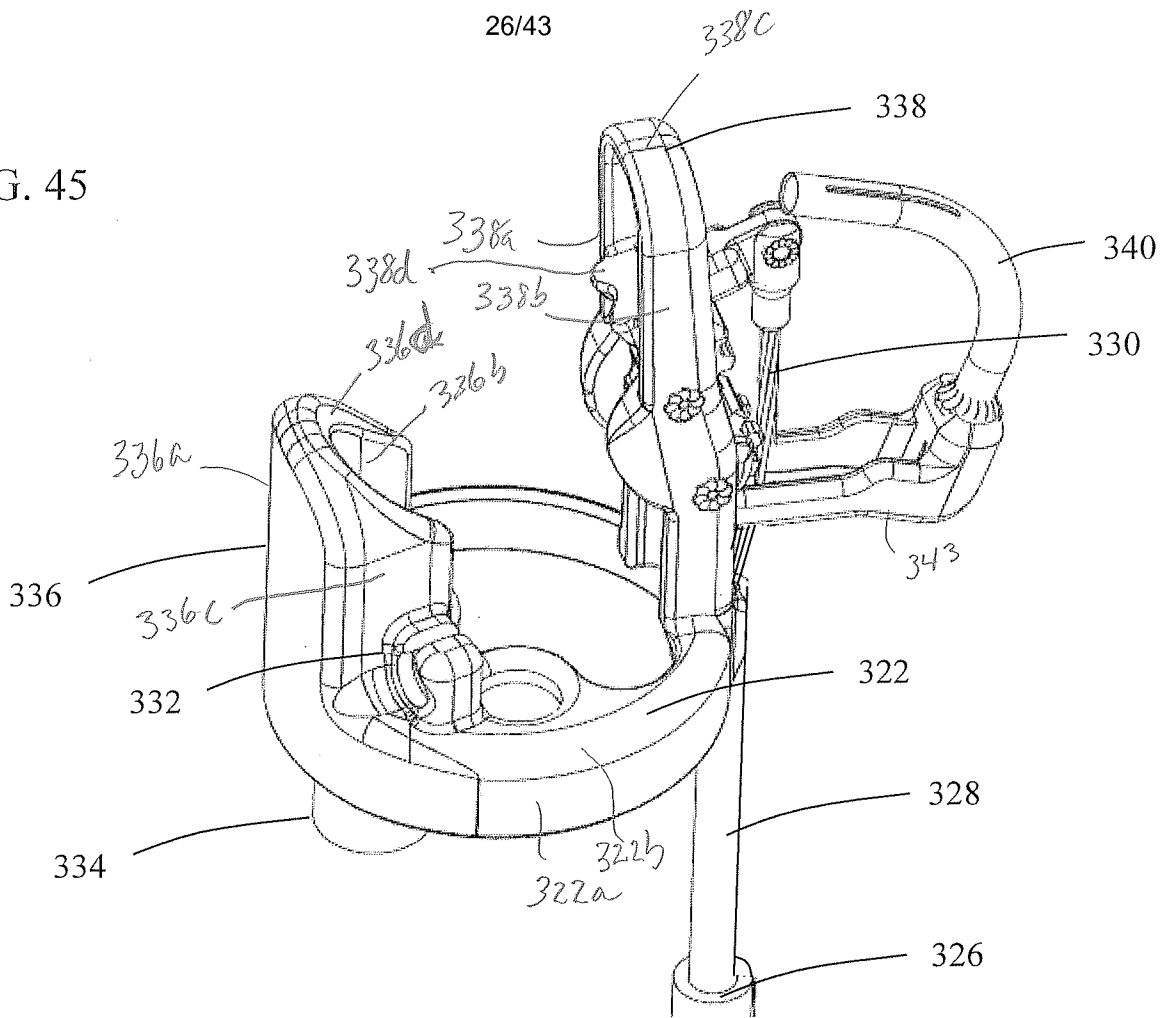
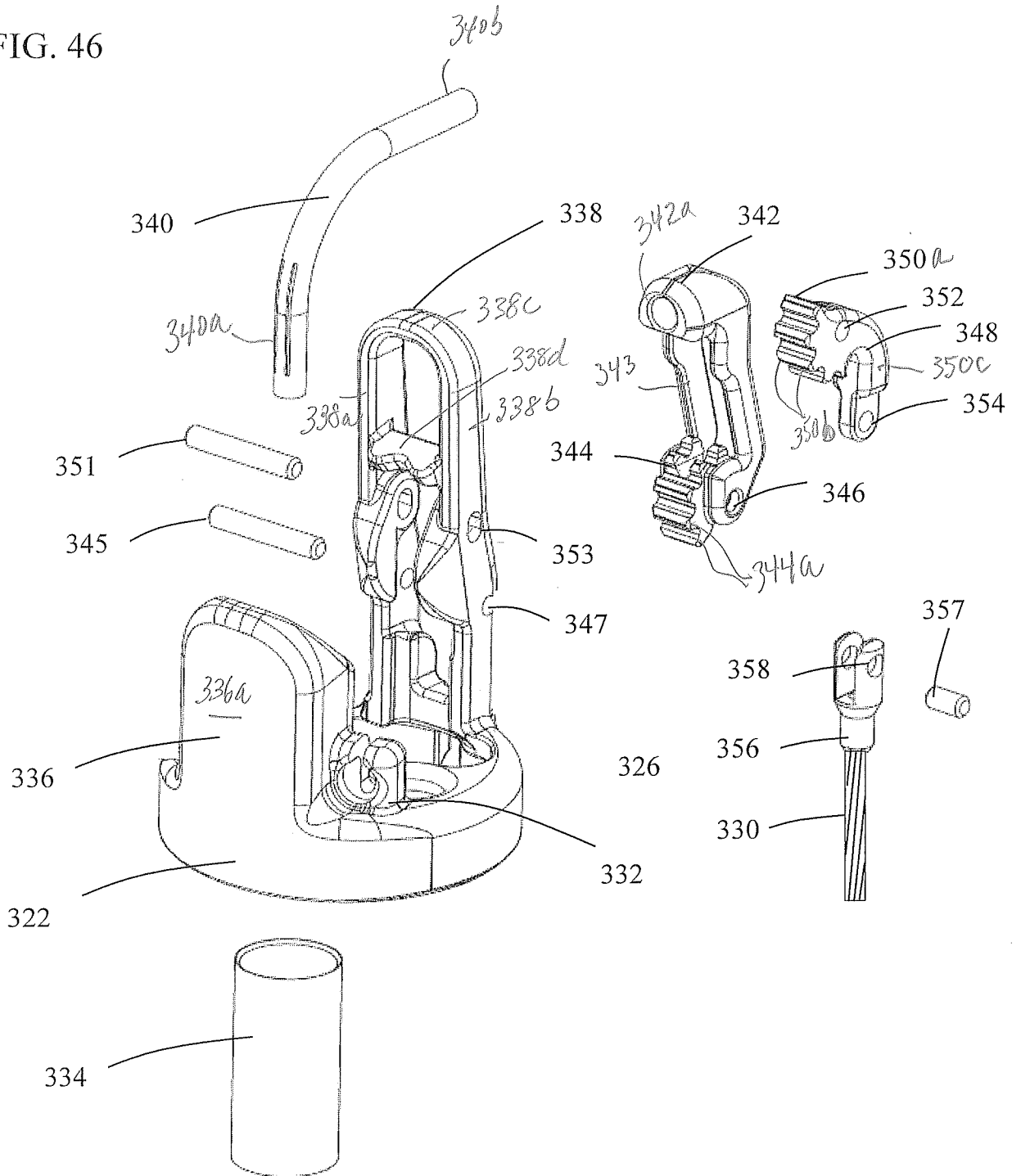

FIG. 45



27/43

FIG. 46



28/43

FIG. 47

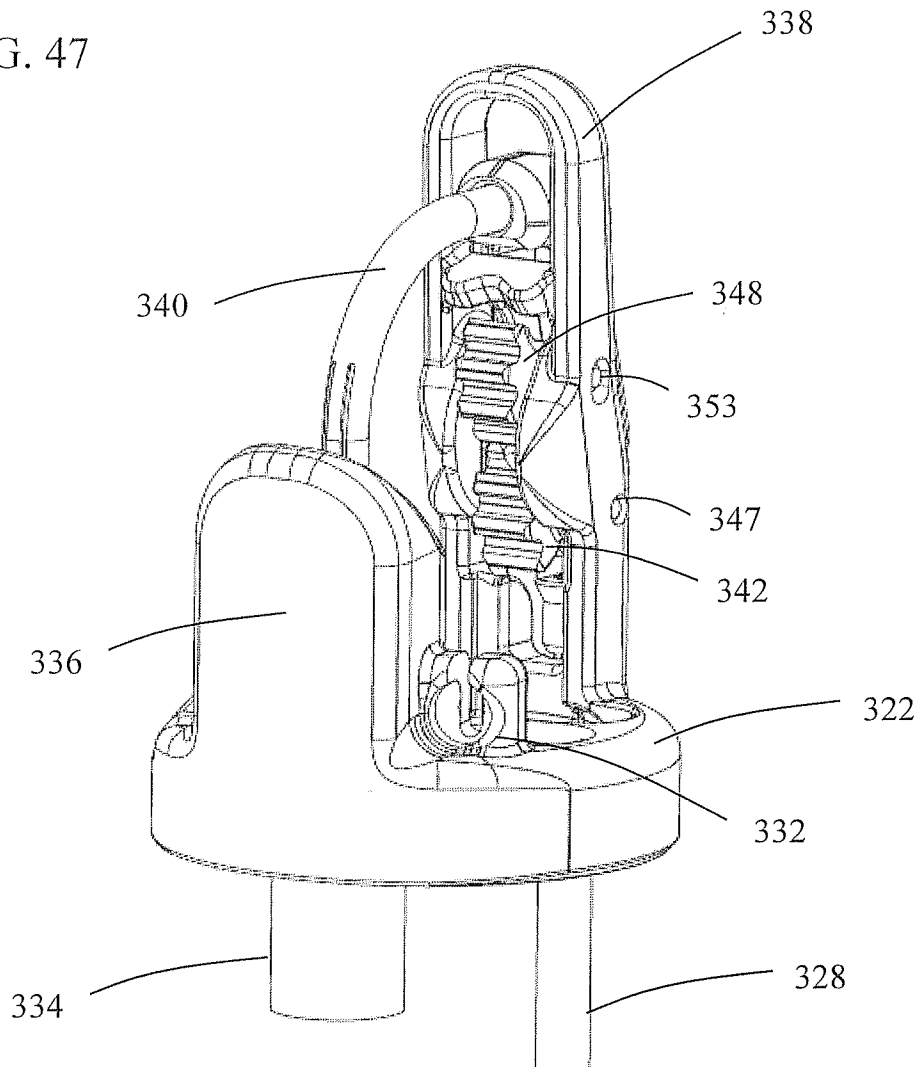

30/43

FIG. 49

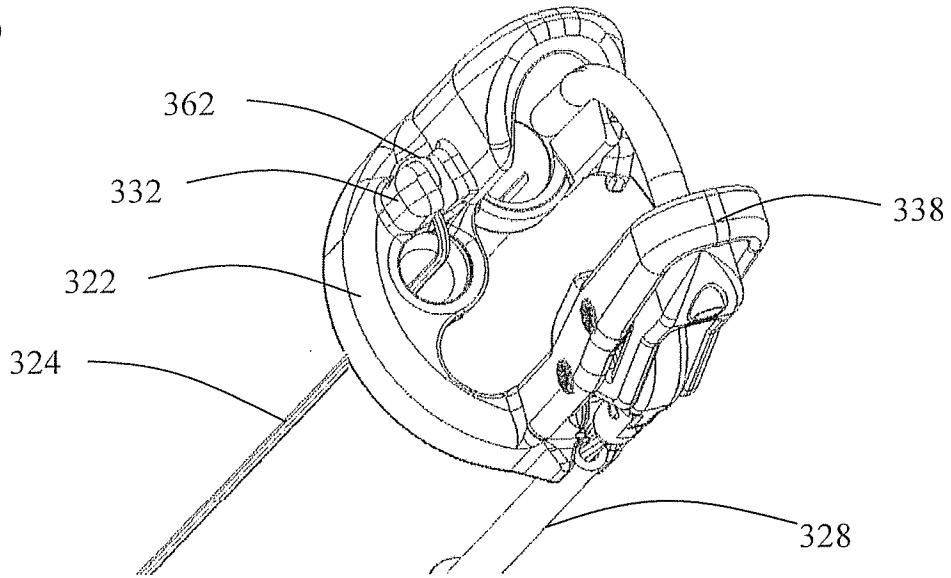
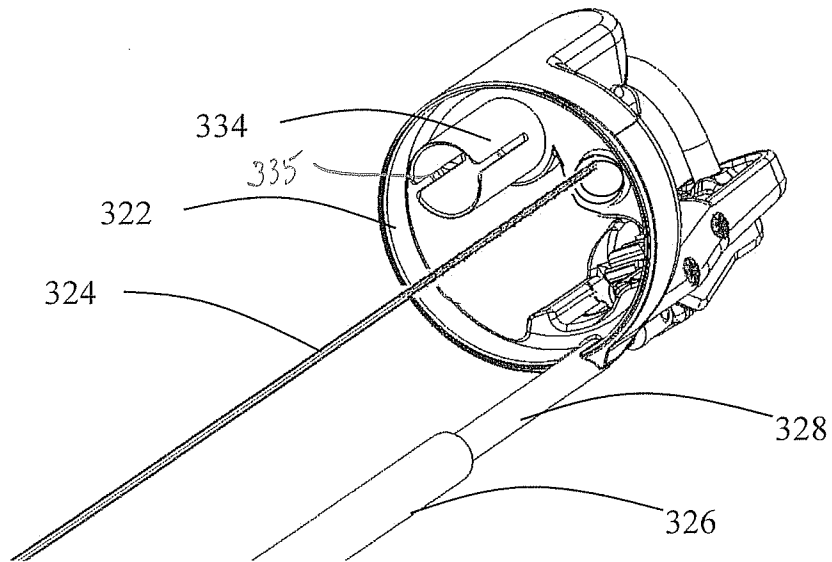

FIG. 50



31/43

FIG. 51

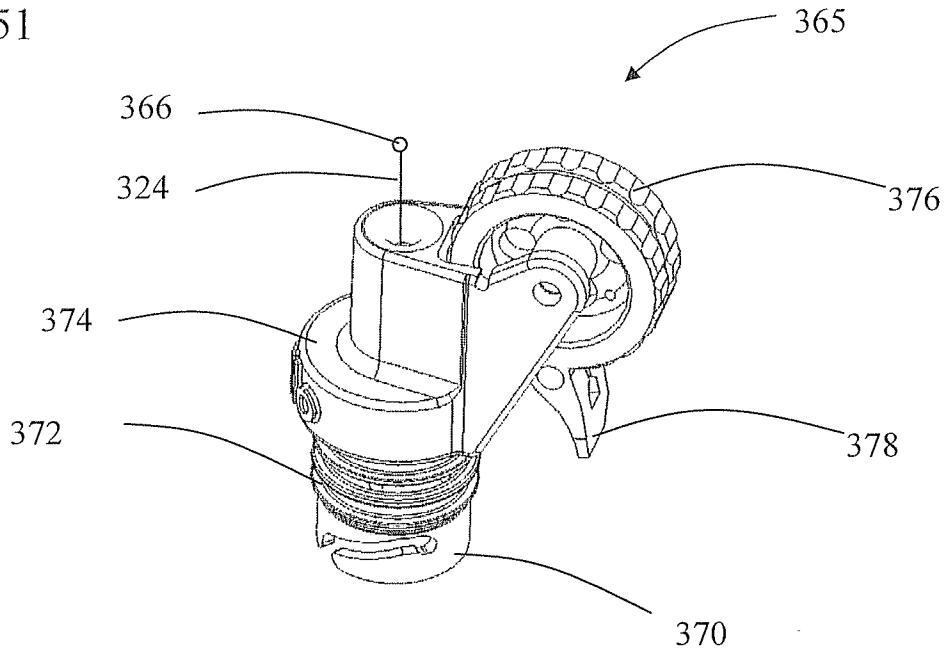

FIG. 52

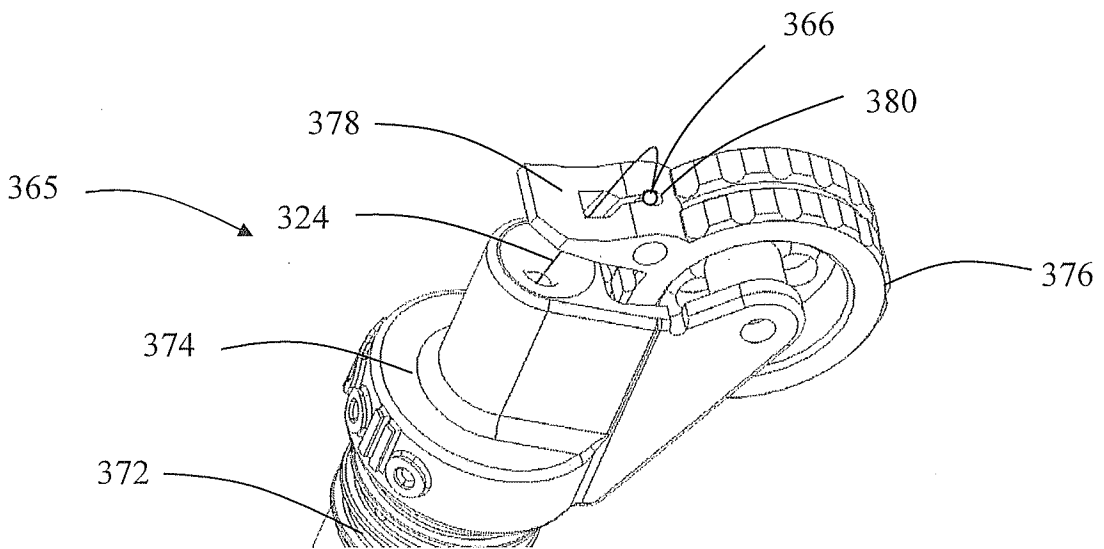

FIG. 53

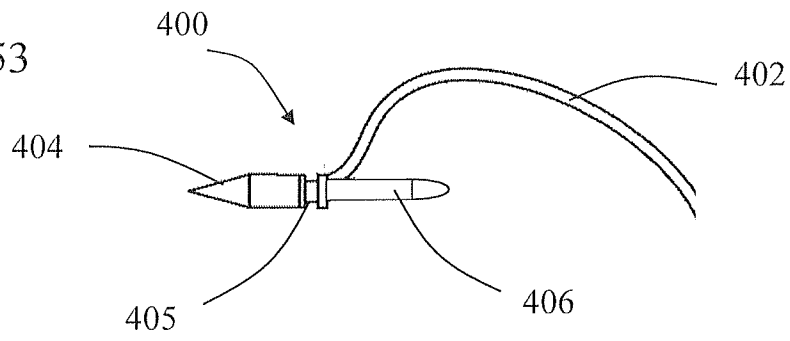

FIG. 54A

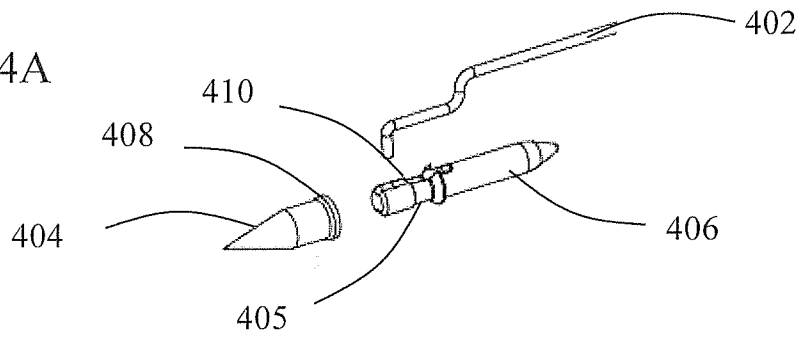

FIG. 54B

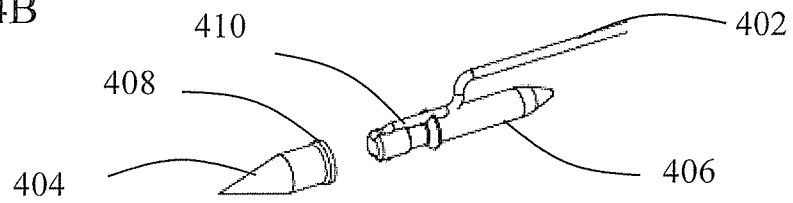

FIG. 54C

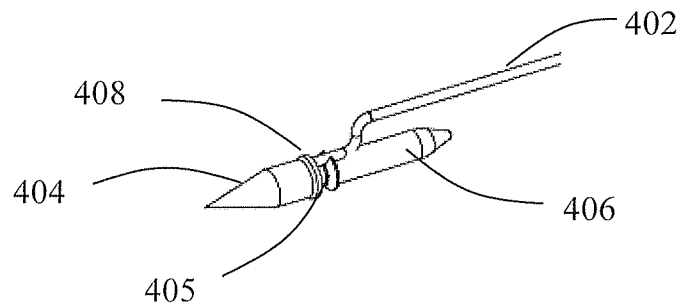

FIG. 55

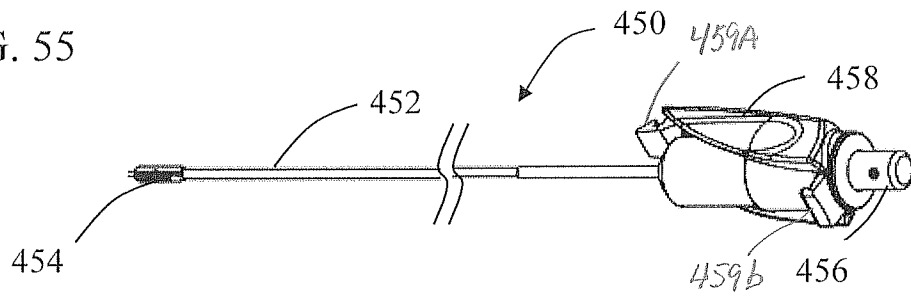

FIG. 56A

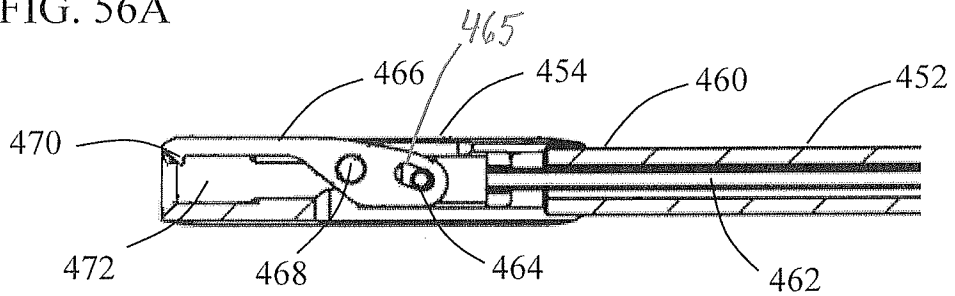

FIG. 56B

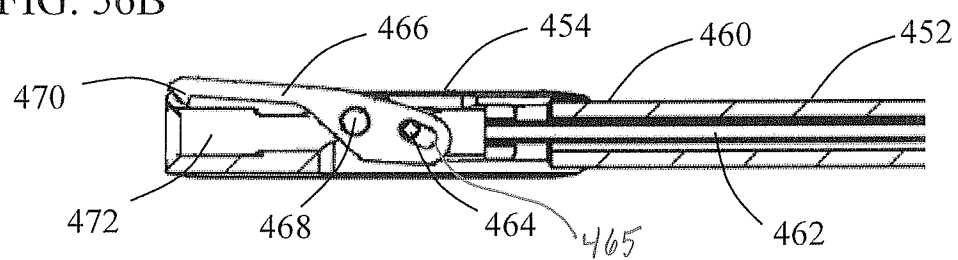

FIG. 57

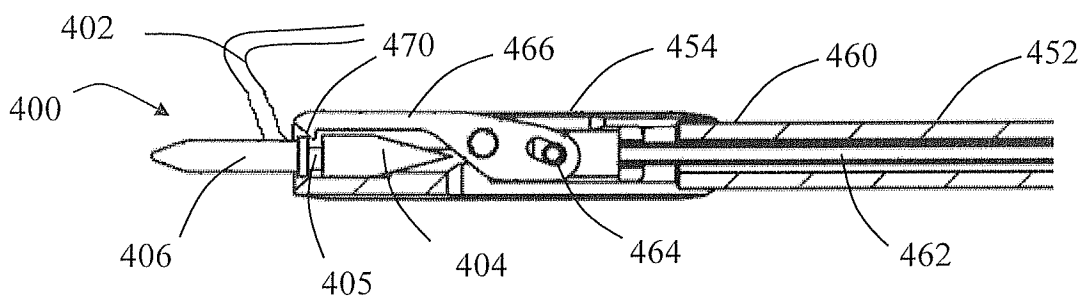

FIG. 58

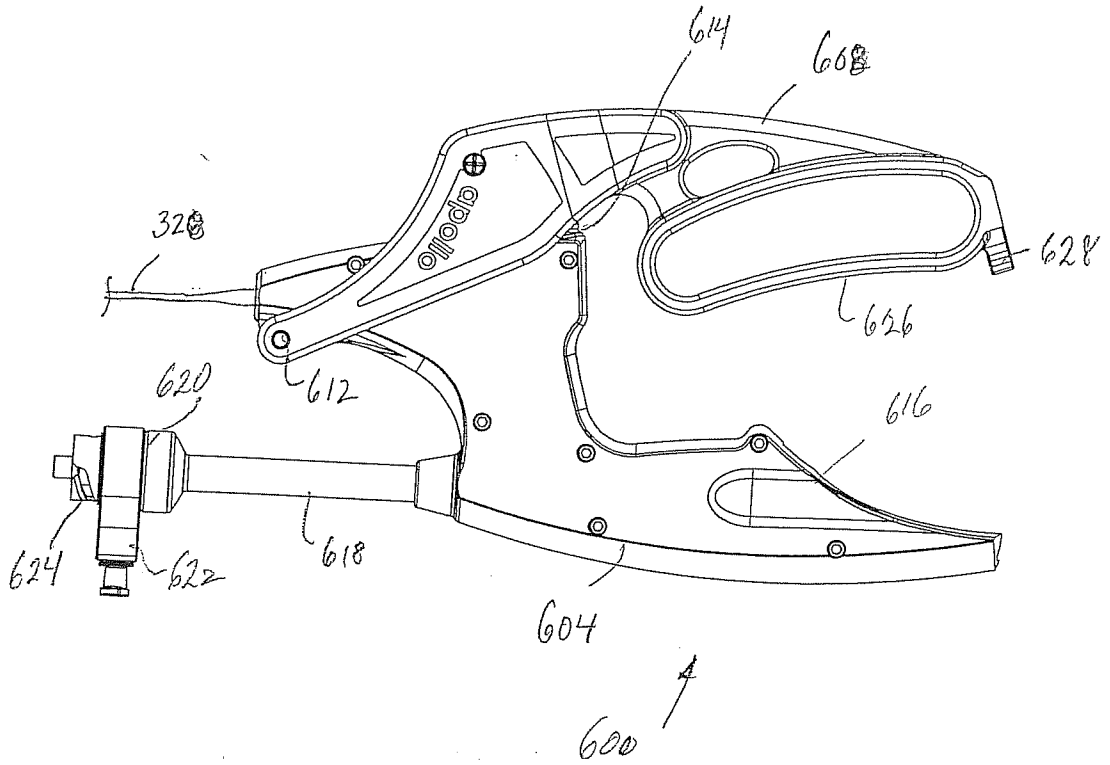

FIG. 59C

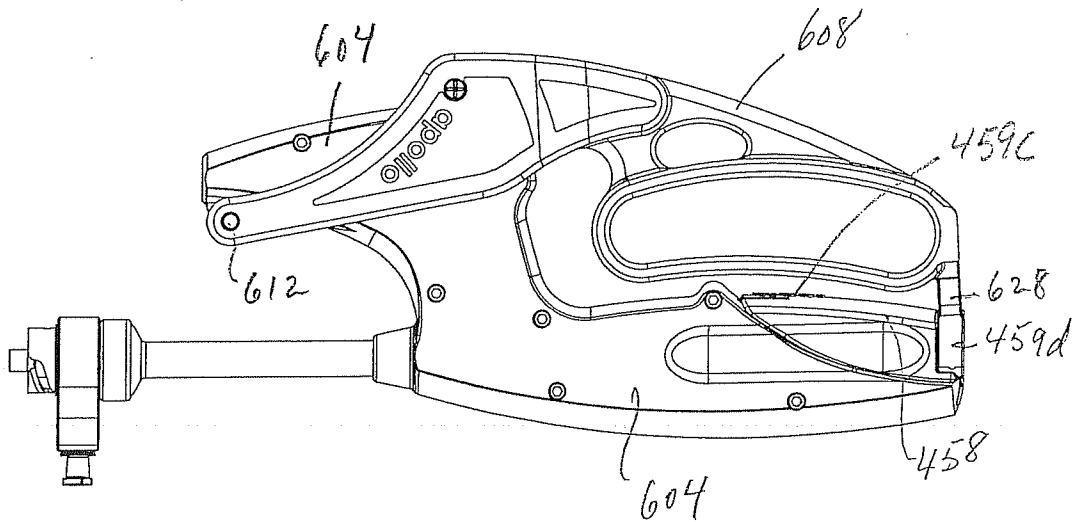

FIG 59A

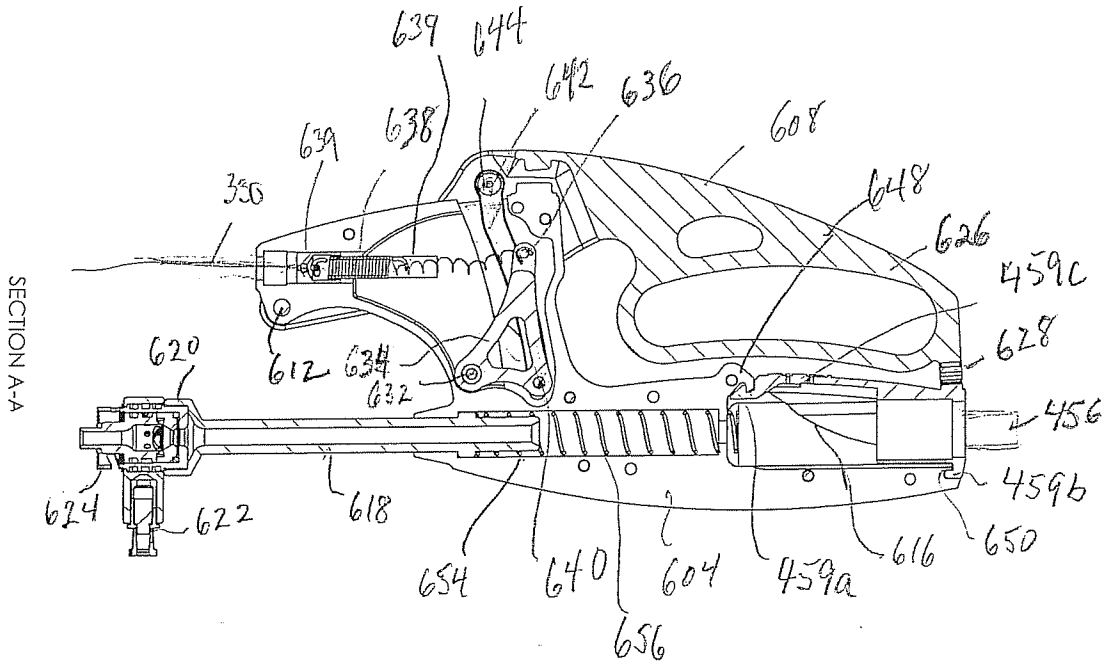

FIG 59B

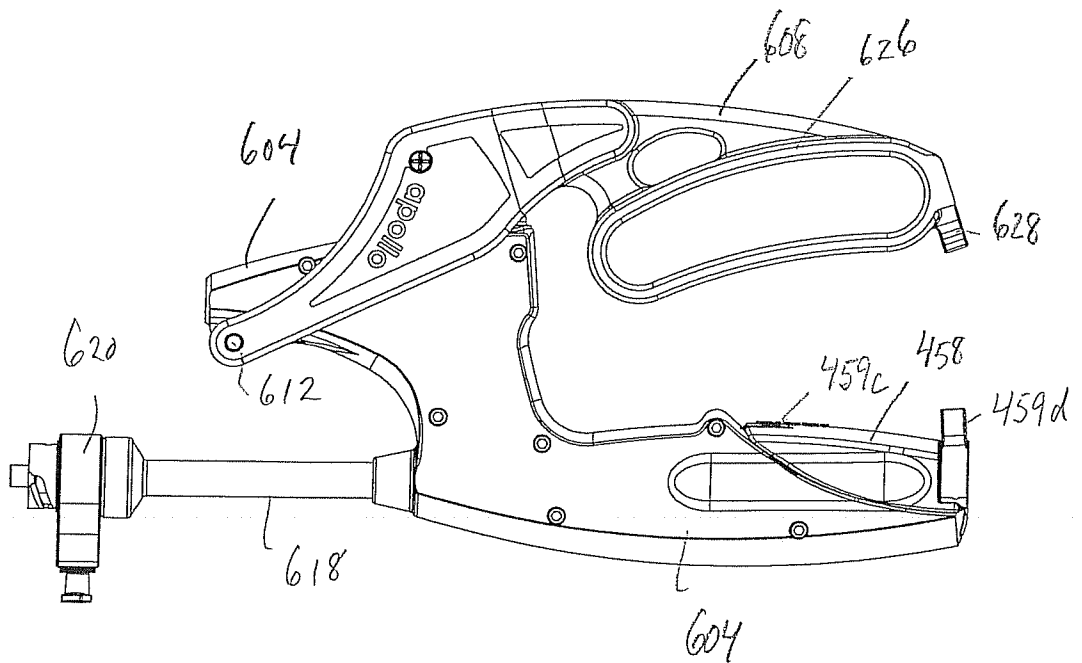

FIG. 60A

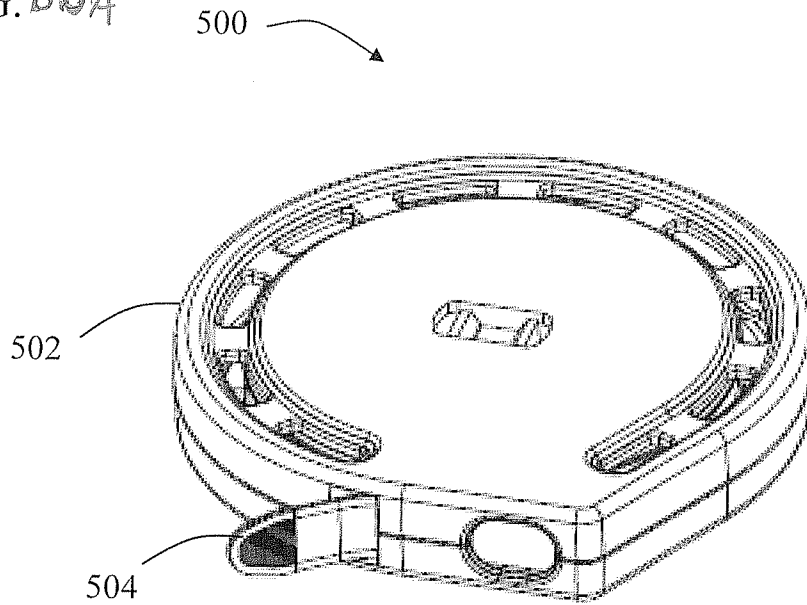
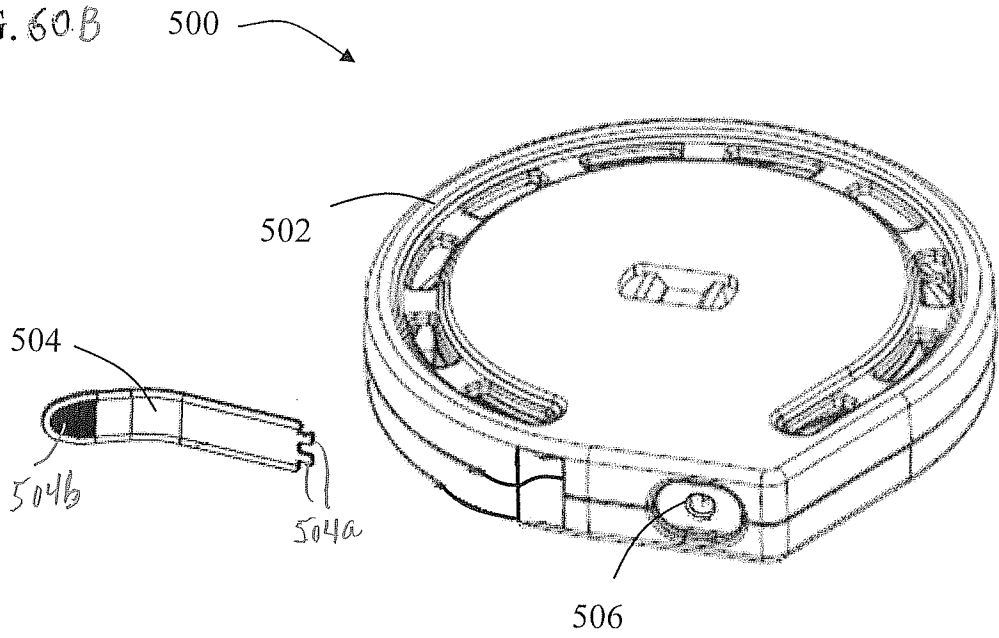

FIG. 60B



37/43

FIG. 60C

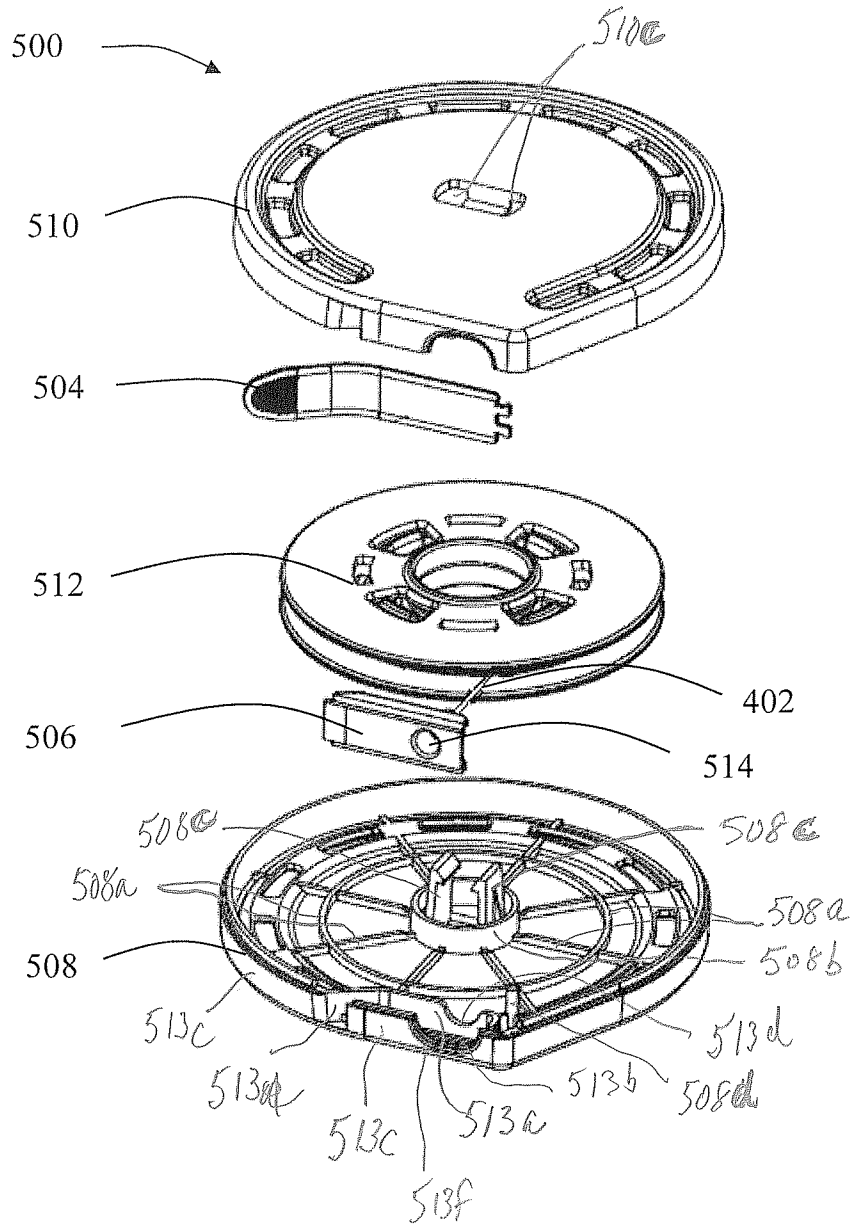

FIG. 61A

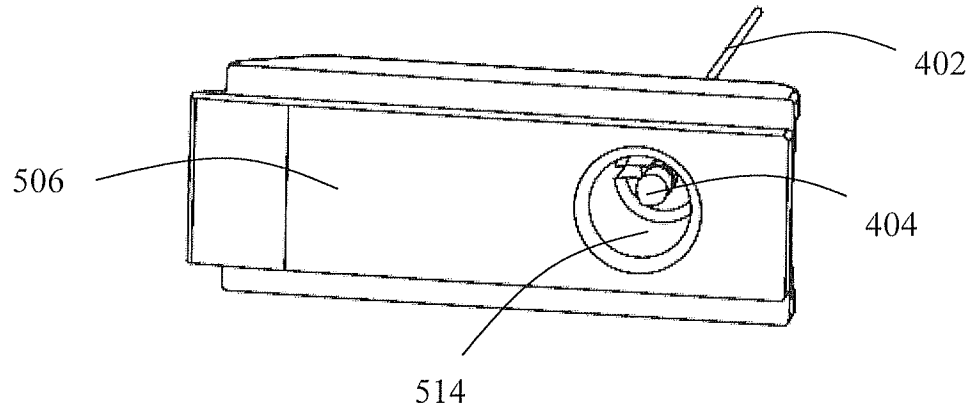

FIG. 61B

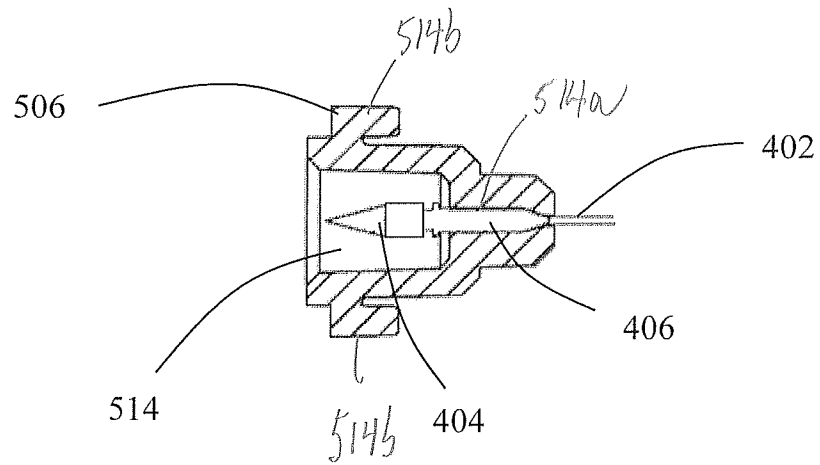

FIG. 62A

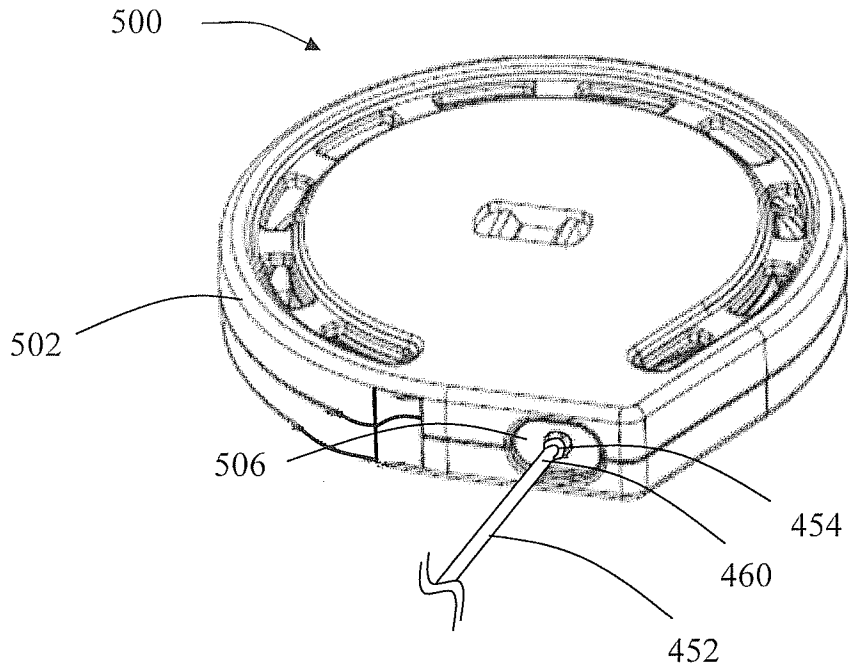

FIG. 62B

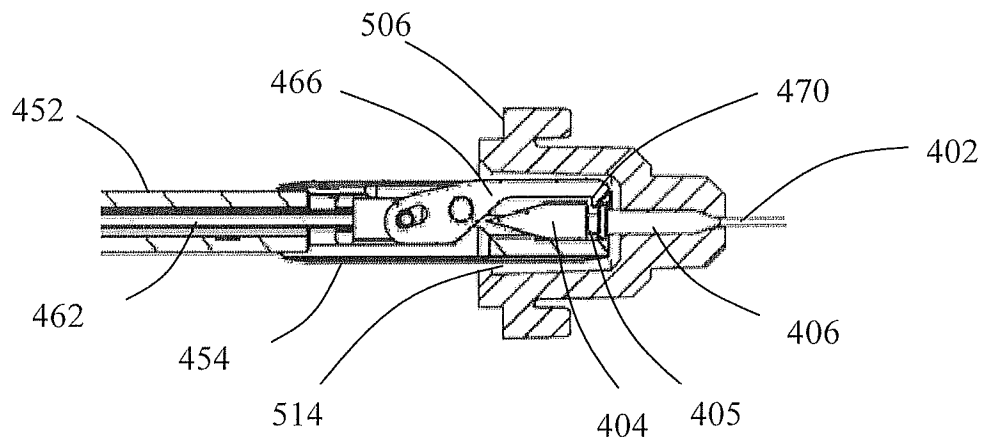

FIG. 63

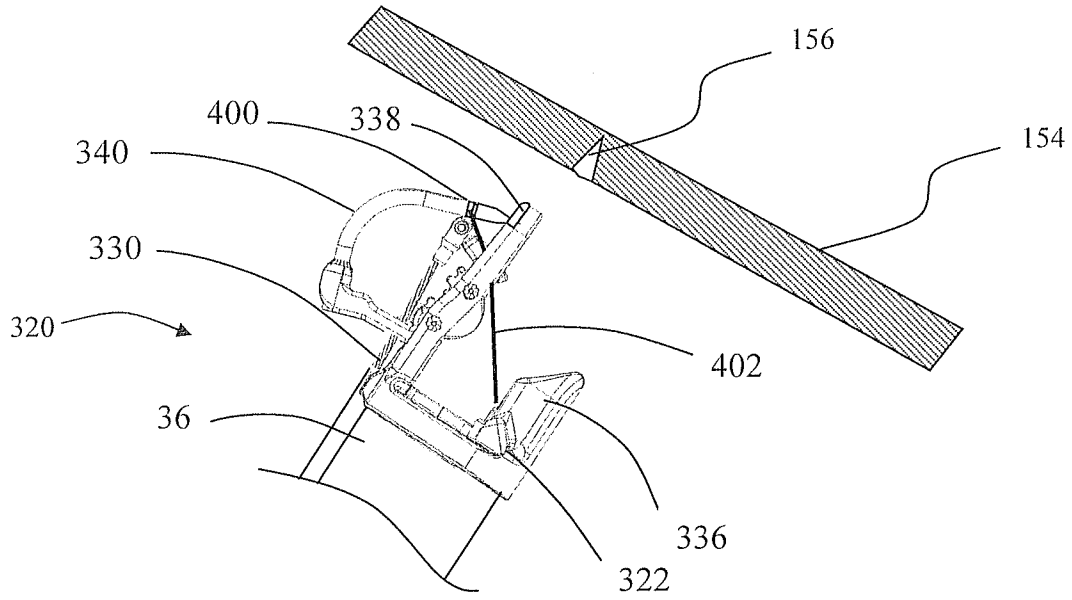

FIG. 64

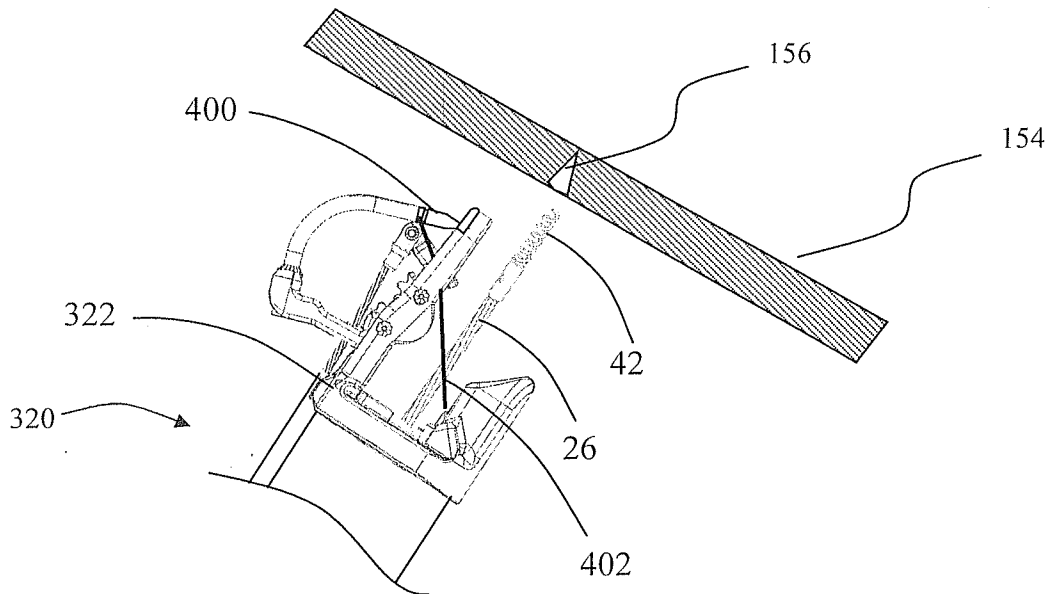

FIG. 65

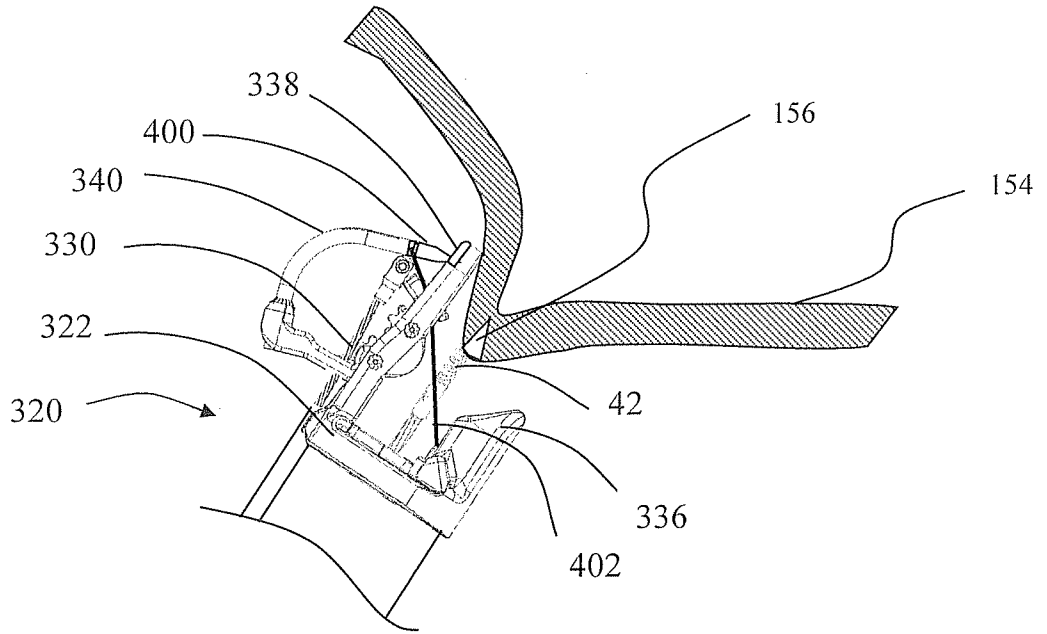

FIG. 66

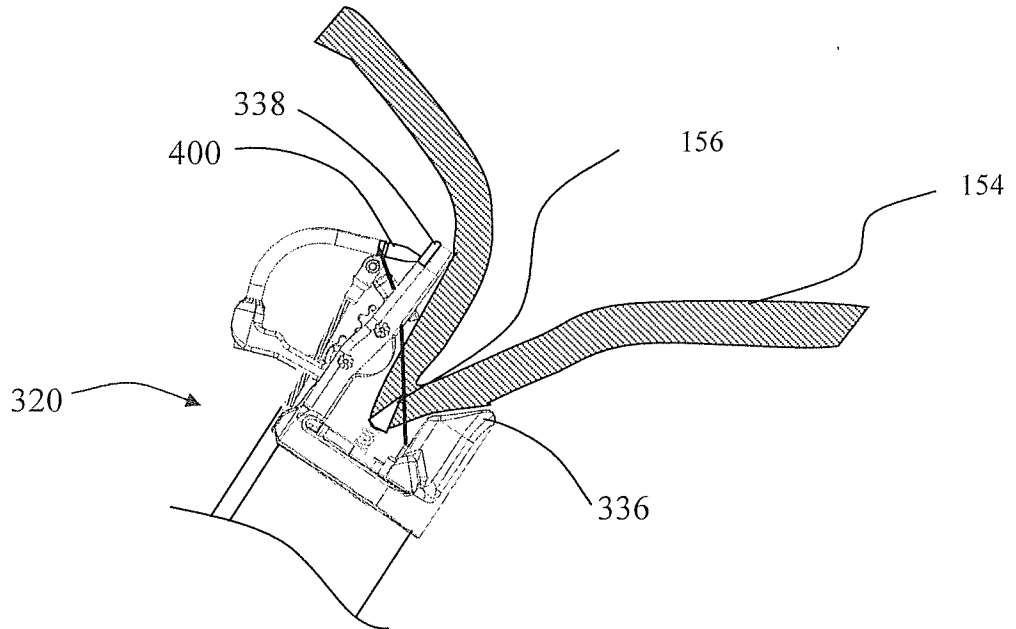

FIG. 67

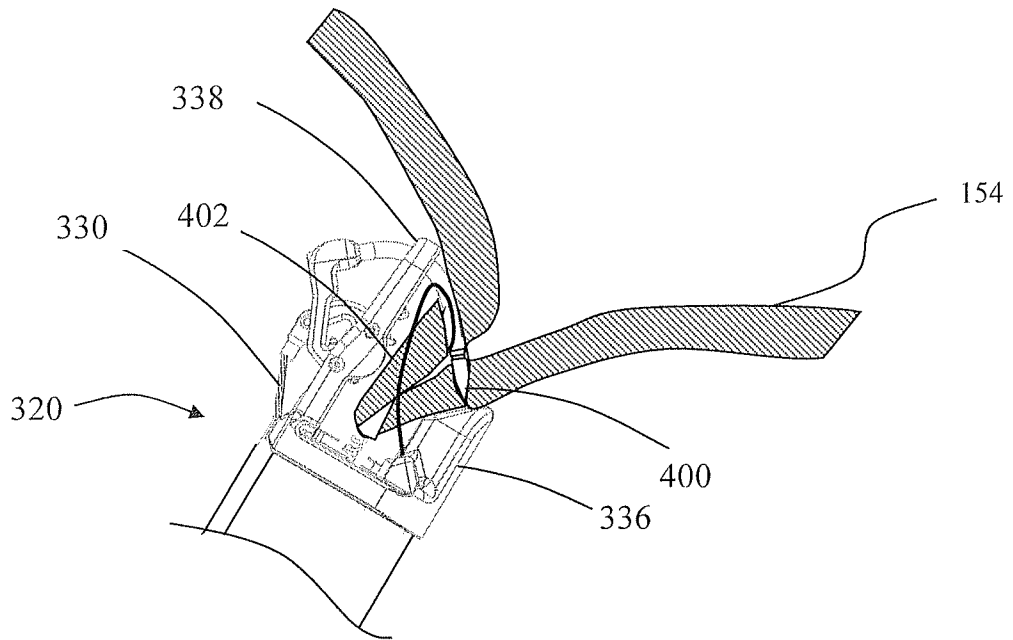

FIG. 68

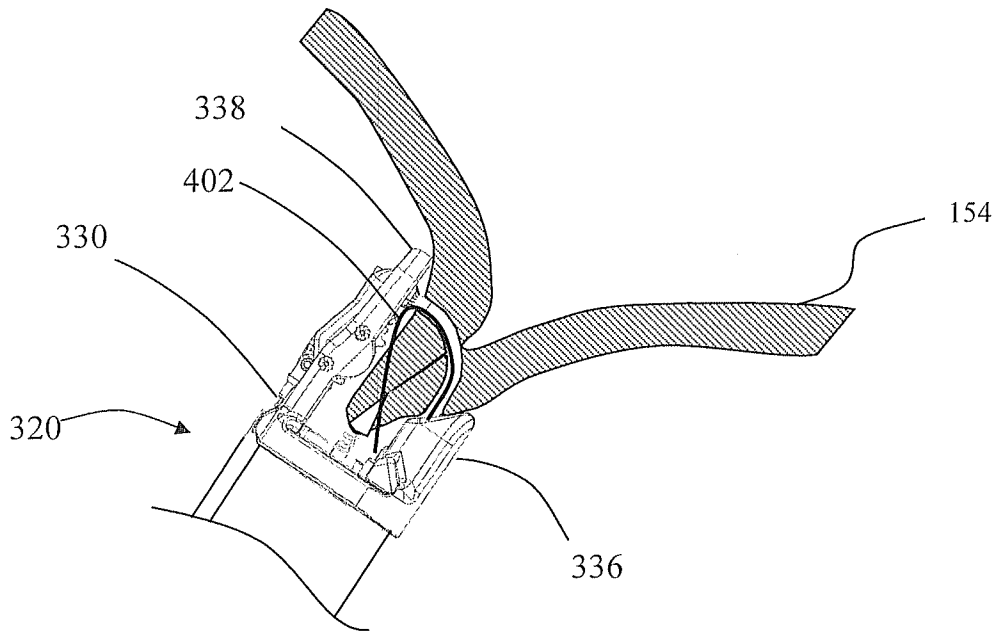
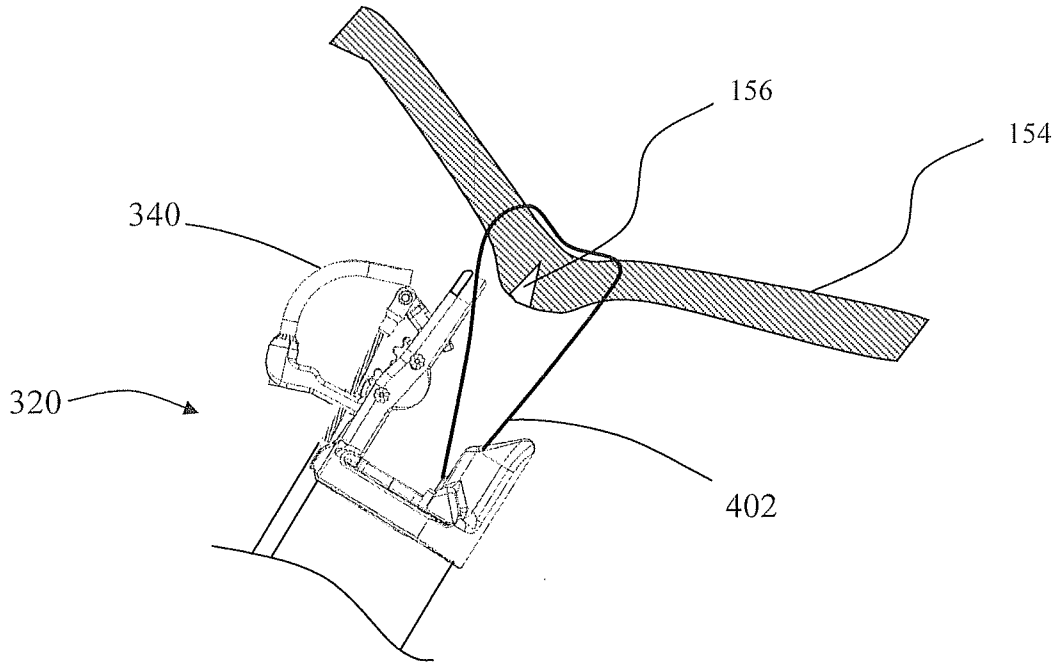

FIG. 69

43/43



INTERNATIONAL SEARCH REPORT

International application No.

PCT/US2009/047508

A. CLASSIFICATION OF SUBJECT MATTER IPC(8) - A61B 17/04 (2009.01) USPC - 606/144 According to International Patent Classification (IPC) or to both national classification and IPC		
B. FIELDS SEARCHED Minimum documentation searched (classification system followed by classification symbols) IPC(8) - A61B 1/00, 17/04, 17/06, 17/062 (2009.01) USPC - 600/104, 106, 127, 129; 606/139, 144, 145, 147, 148 Documentation searched other than minimum documentation to the extent that such documents are included in the fields searched Electronic data base consulted during the international search (name of data base and, where practicable, search terms used) PatBase		
C. DOCUMENTS CONSIDERED TO BE RELEVANT		
Category*	Citation of document, with indication, where appropriate, of the relevant passages	Relevant to claim No.
X	US 2005/0149067 A1 (TAKEMOTO et al) 07 July 2005 (07.07.2005) entire document	1-5, 7-12, 17, 19-27, 60-62, 73-76
---		-----
Y		6, 28-59
Y	US 2002/0116011 A1 (CHEE CHUNG et al) 22 August 2002 (22.08.2002) entire document	6, 28-29, 37-46, 53-59
Y	US 2005/0065401 A1 (SAADAT et al) 24 March 2005 (24.03.2005) entire document	30-36
Y	US 5,527,321 A (HINCHLIFFE) 18 June 1996 (18.06.1996) entire document	46-53
<input type="checkbox"/> Further documents are listed in the continuation of Box C. <input type="checkbox"/>		
* Special categories of cited documents: "A" document defining the general state of the art which is not considered to be of particular relevance "E" earlier application or patent but published on or after the international filing date "L" document which may throw doubts on priority claim(s) or which is cited to establish the publication date of another citation or other special reason (as specified) "O" document referring to an oral disclosure, use, exhibition or other means "P" document published prior to the international filing date but later than the priority date claimed	"T" later document published after the international filing date or priority date and not in conflict with the application but cited to understand the principle or theory underlying the invention "X" document of particular relevance; the claimed invention cannot be considered novel or cannot be considered to involve an inventive step when the document is taken alone "Y" document of particular relevance; the claimed invention cannot be considered to involve an inventive step when the document is combined with one or more other such documents, such combination being obvious to a person skilled in the art "&" document member of the same patent family	
Date of the actual completion of the international search 07 October 2009		Date of mailing of the international search report 15 OCT 2009
Name and mailing address of the ISA/US Mail Stop PCT, Attn: ISA/US, Commissioner for Patents P.O. Box 1450, Alexandria, Virginia 22313-1450 Facsimile No. 571-273-3201		Authorized officer: Blaine R. Copenheaver PCT Helpdesk: 571-272-4300 PCT OSP: 571-272-7774

INTERNATIONAL SEARCH REPORT

International application No.
PCT/US2009/047508

Box No. II Observations where certain claims were found unsearchable (Continuation of item 2 of first sheet)

This international search report has not been established in respect of certain claims under Article 17(2)(a) for the following reasons:

- 1. Claims Nos.:
because they relate to subject matter not required to be searched by this Authority, namely:

- 2. Claims Nos.:
because they relate to parts of the international application that do not comply with the prescribed requirements to such an extent that no meaningful international search can be carried out, specifically:

- 3. Claims Nos.: 13-16, 18 and 72
because they are dependent claims and are not drafted in accordance with the second and third sentences of Rule 6.4(a).

Box No. III Observations where unity of invention is lacking (Continuation of item 3 of first sheet)

This International Searching Authority found multiple inventions in this international application, as follows:

See extra sheet.

- 1. As all required additional search fees were timely paid by the applicant, this international search report covers all searchable claims.
- 2. As all searchable claims could be searched without effort justifying additional fees, this Authority did not invite payment of additional fees.
- 3. As only some of the required additional search fees were timely paid by the applicant, this international search report covers only those claims for which fees were paid, specifically claims Nos.:

- 4. No required additional search fees were timely paid by the applicant. Consequently, this international search report is restricted to the invention first mentioned in the claims; it is covered by claims Nos.:
1-12, 17, 19-62 and 73-76

- Remark on Protest**
- The additional search fees were accompanied by the applicant's protest and, where applicable, the payment of a protest fee.
 - The additional search fees were accompanied by the applicant's protest but the applicable protest fee was not paid within the time limit specified in the invitation.
 - No protest accompanied the payment of additional search fees.

INTERNATIONAL SEARCH REPORT

International application No.

PCT/US2009/047508

Group I, claims 1-12, 17, 19-62 and 73-76, are drawn to a treatment device for use with an endoscope or guide member and methods of suturing therewith.

Group II, claims 63-71, are drawn to a suture dispenser.

The inventions listed as Groups I and II do not relate to a single general inventive concept under PCT Rule 13.1 because, under PCT Rule 13.2, they lack the same or corresponding special technical features for the following reasons: the special technical feature of the Group I invention, a needle holder arm, is not present in the invention of Group II; the special technical feature of the Group II invention, a suture dispenser, is not present in the invention of Group I.

Since none of the special technical features of the Group I and II inventions is found in more than one of the inventions, unity of invention is lacking.

Claims 13-16, 18 and 72 have been found to be unsearchable under Article 17(2)(b) because of defects under Article 17(2)(a) and therefore have not been included with any invention because they are multiple dependent claims not drafted in accordance with the second and third sentences of Rule 6.4(a).