



- (51) **International Patent Classification:**
H01L 21/683 (2006.01) *B23Q 3/15* (2006.01)
H02N 13/00 (2006.01)
- (21) **International Application Number:**
PCT/US2014/071478
- (22) **International Filing Date:**
19 December 2014 (19.12.2014)
- (25) **Filing Language:** English
- (26) **Publication Language:** English
- (30) **Priority Data:**
61/920,456 23 December 2013 (23.12.2013) US
14/571,000 15 December 2014 (15.12.2014) US
- (71) **Applicant: KLA-TENCOR CORPORATION** [US/US];
KLA-TENCOR CORPORATION, Legal Department, One
Technology Drive, Milpitas, Milpitas, California 95035
(US).
- (72) **Inventor: HUANG, Luping;** 5586 N. Dublin Ranch
Drive, Dublin, California 94568 (US).
- (74) **Agents: MCANDREWS, Kevin et al.;** KLA-TENCOR
CORP., Legal Department, One Technology Drive, Mil-
pitas, Milpitas, California 95035 (US).
- (81) **Designated States** (unless otherwise indicated, for every
kind of national protection available): AE, AG, AL, AM,
AO, AT, AU, AZ, BA, BB, BG, BH, BN, BR, BW, BY,
BZ, CA, CH, CL, CN, CO, CR, CU, CZ, DE, DK, DM,
DO, DZ, EC, EE, EG, ES, FI, GB, GD, GE, GH, GM, GT,
HN, HR, HU, ID, IL, IN, IR, IS, JP, KE, KG, KN, KP, KR,
KZ, LA, LC, LK, LR, LS, LU, LY, MA, MD, ME, MG,
MK, MN, MW, MX, MY, MZ, NA, NG, NI, NO, NZ, OM,
PA, PE, PG, PH, PL, PT, QA, RO, RS, RU, RW, SA, SC,
SD, SE, SG, SK, SL, SM, ST, SV, SY, TH, TJ, TM, TN,
TR, TT, TZ, UA, UG, US, UZ, VC, VN, ZA, ZM, ZW.
- (84) **Designated States** (unless otherwise indicated, for every
kind of regional protection available): ARIPO (BW, GH,
GM, KE, LR, LS, MW, MZ, NA, RW, SD, SL, ST, SZ,
TZ, UG, ZM, ZW), Eurasian (AM, AZ, BY, KG, KZ, RU,
TJ, TM), European (AL, AT, BE, BG, CH, CY, CZ, DE,
DK, EE, ES, FI, FR, GB, GR, HR, HU, IE, IS, IT, LT, LU,
LV, MC, MK, MT, NL, NO, PL, PT, RO, RS, SE, SI, SK,
SM, TR), OAPI (BF, BJ, CF, CG, CI, CM, GA, GN, GQ,
GW, KM, ML, MR, NE, SN, TD, TG).
- Published:**
— with international search report (Art. 21(3))

(54) **Title:** SYSTEM AND METHOD FOR NON-CONTACT WAFER CHUCKING

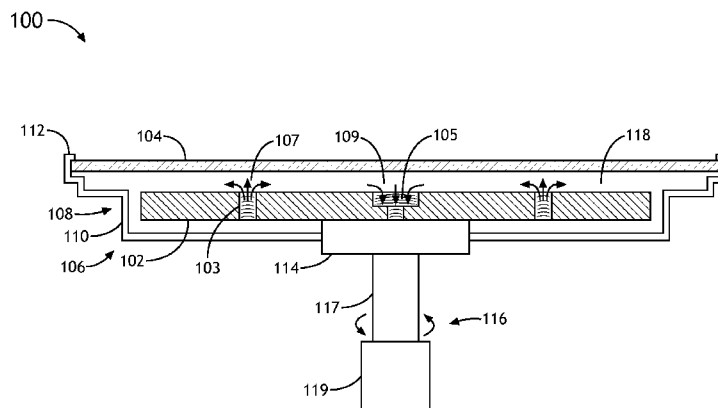

FIG. 1A

(57) **Abstract:** A non-contact wafer chucking apparatus includes a wafer chuck and a gripper assembly coupled to a portion of the wafer chuck. The wafer chuck includes pressurized gas elements configured to generate pressurized gas regions across a surface of the wafer chuck suitable for elevating the wafer above the surface of the wafer chuck. The wafer chuck further includes vacuum elements configured to generate reduced pressure regions across the surface of the wafer chuck having a pressure lower than the pressurized gas regions. The reduced pressure regions are suitable for securing the wafer above the wafer chuck without contact to the wafer chuck. The chucking apparatus includes a rotational drive unit configured to selectively rotate the wafer chuck. The gripper elements are reversibly couplable to an edge portion of the wafer so as to secure the wafer such that the wafer and gripper assembly rotate synchronously with the wafer chuck.



SYSTEM AND METHOD FOR NON-CONTACT WAFER CHUCKING

CROSS-REFERENCE TO RELATED APPLICATION

[0001] The present application claims the benefit under 35 U.S.C. § 119(e) of U.S. Provisional Application Serial Number **61/920,456**, filed **December 23, 2013**, entitled **WAFER EDGE GRIPPING CHUCK MECHANISM WITHOUT CONTACT ON BACK SIDE**, naming **Luping Huang** as an inventor, which is incorporated herein by reference in the entirety.

TECHNICAL FIELD

[0002] The present invention generally relates to a wafer chuck for use in a wafer characterization system and, in particular, to a non-contact wafer chuck.

BACKGROUND

[0003] As tolerances on semiconductor device fabrication processes continue to narrow, the demand for improved semiconductor wafer review tools continues to increase. One such review tool includes a wafer inspection tool, such as a wafer edge inspection tool. In such an optical system, an associated wafer chuck may be used to rotate the wafer during edge inspection. Some wafer chucks may provide an air bearing that elevates the wafer above the wafer chuck surface. Such systems, however, suffer from height variations associated with the wafer chuck as the wafer is rotated with respect to the underlying wafer chuck. Therefore, it would be advantageous to provide a system and method that cures the defects identified in the previous art.

SUMMARY

[0004] An apparatus for non-contact chucking a wafer is disclosed, in accordance with an illustrative embodiment of the present invention. In one illustrative embodiment, the apparatus includes a wafer chuck. In one illustrative embodiment, the wafer chuck includes one or more pressurized gas elements configured to generate one or more pressurized gas regions across a surface of the wafer chuck suitable for elevating the wafer above the surface of the wafer chuck. In another illustrative embodiment, the wafer chuck further includes one or more vacuum elements configured to generate one or more reduced pressure regions across the surface of the wafer chuck. In one illustrative embodiment, the reduced pressure regions have a pressure lower than the pressurized gas regions. In another illustrative embodiment, the one or more reduced pressure regions are suitable for securing the wafer above the wafer chuck without contact to the wafer chuck. In another illustrative embodiment, the apparatus includes a gripper assembly coupled to a portion of the wafer chuck. In another illustrative embodiment, the apparatus includes a rotational drive unit mechanically coupled to the wafer chuck. In another illustrative embodiment, the rotational drive unit is configured to selectively rotate the wafer chuck. In another illustrative embodiment, the gripper assembly is reversibly couplable to one or more edge portions of the wafer so as to laterally secure the wafer such that the wafer and the gripper assembly rotate synchronously with the wafer chuck during rotation of the wafer chuck by the rotational drive unit.

[0005] An optical system is disclosed, in accordance with an illustrative embodiment of the present invention. In one illustrative embodiment, the optical system includes a wafer chucking sub-system. In another illustrative embodiment, the optical system includes an illumination source configured to illuminate one or more portions of the wafer secured by the wafer chucking sub-system. In another illustrative embodiment, the optical system includes a detector configured to collect illumination from the illuminated one or more

portions of the wafer. In one illustrative embodiment, wafer chucking sub-system includes a wafer chuck. In one illustrative embodiment, the wafer chuck includes one or more pressurized gas elements configured to generate one or more pressurized gas regions across a surface of the wafer chuck suitable for elevating the wafer above the surface of the wafer chuck. In another illustrative embodiment, the wafer chuck further includes one or more vacuum elements configured to generate one or more reduced pressure regions across the surface of the wafer chuck. In one illustrative embodiment, the reduced pressure regions have a pressure lower than the pressurized gas regions. In another illustrative embodiment, the one or more reduced pressure regions are suitable for securing the wafer above the wafer chuck without contact to the wafer chuck. In another illustrative embodiment, the wafer chucking sub-system includes a gripper assembly coupled to a portion of the wafer chuck. In another illustrative embodiment, the wafer chucking sub-system includes a rotational drive unit mechanically coupled to the wafer chuck. In another illustrative embodiment, the rotational drive unit is configured to selectively rotate the wafer chuck. In another illustrative embodiment, the gripper assembly is reversibly couplable to one or more edge portions of the wafer so as to laterally secure the wafer such that the wafer and the gripper assembly rotate synchronously with the wafer chuck during rotation of the wafer chuck by the rotational drive unit.

[0006] An apparatus for non-contact chucking of a wafer is disclosed, in accordance with an illustrative embodiment of the present invention. In one illustrative embodiment, the method includes generating one or more pressurized gas regions across a surface of a wafer chuck in order to elevate the wafer above the surface of the wafer chuck. In another illustrative embodiment, the method includes generating one or more reduced pressure regions across the surface of the wafer chuck in order to secure the wafer above the wafer chuck without contact to the wafer chuck. In another illustrative embodiment, the method includes reversibly coupling a gripper assembly to an edge portion of the wafer in order to rotationally secure the wafer with respect to the wafer chuck. In

another illustrative embodiment, the method includes synchronously rotating the wafer, gripper assembly and the wafer chuck at a selected rotational velocity.

[0007] It is to be understood that both the foregoing general description and the following detailed description are exemplary and explanatory only and are not necessarily restrictive of the invention as claimed. The accompanying drawings, which are incorporated in and constitute a part of the specification, illustrate embodiments of the invention and together with the general description, serve to explain the principles of the invention.

BRIEF DESCRIPTION OF THE DRAWINGS

[0008] The numerous advantages of the disclosure may be better understood by those skilled in the art by reference to the accompanying figures in which:

FIG. 1A is a cross-sectional view of a non-contact wafer chucking system, in accordance with one embodiment of the present disclosure.

FIG. 1B is a cross-sectional view of a wafer chuck of a non-contact wafer chucking system, in accordance with one embodiment of the present disclosure.

FIG. 1C is a top view of a wafer chuck of a non-contact wafer chucking system, in accordance with one embodiment of the present disclosure.

FIG. 1D is a schematic bottom view of a non-contact wafer chucking system, in accordance with one embodiment of the present disclosure.

FIG. 1E is a schematic top view of a non-contact wafer chucking system, in accordance with one embodiment of the present disclosure.

FIG. 1F is a schematic bottom view of a non-contact wafer chucking system having a gripper assembly in a disengaged state, in accordance with one embodiment of the present disclosure.

FIG. 1G is a schematic bottom view of a non-contact wafer chucking system having a gripper assembly in an engaged state, in accordance with one embodiment of the present disclosure.

FIG. 2A is a simplified schematic view of a wafer inspection system equipped with a non-contact wafer chucking system, in accordance with one embodiment of the present disclosure.

FIG. 2B is a simplified schematic view of a wafer inspection system equipped with a non-contact wafer chucking system, in accordance with one embodiment of the present disclosure.

FIG. 3 is a simplified schematic view of a wafer edge inspection system equipped with a non-contact wafer chucking system, in accordance with one embodiment of the present disclosure.

FIG. 4 is flow diagram of depicting a method for non-contact chucking of a wafer, in accordance with one embodiment of the present disclosure.

DETAILED DESCRIPTION OF THE INVENTION

[0009] Reference will now be made in detail to the subject matter disclosed, which is illustrated in the accompanying drawings.

[0010] Referring generally to FIGS. 1A through 4, a system and method for non-contact chucking of a wafer is described in accordance with the present disclosure. The use of a non-contact wafer chuck is described generally in U.S. Patent No. 8,444,126 to Siebert et al., issued on May 21, 2013, which is incorporated herein by reference in the entirety.

[0011] Embodiments of the present disclosure are directed to a wafer chuck and gripping device suitable for elevating and securing a wafer, such as a semiconductor wafer (e.g., 200 to 500 mm wafer), above the wafer chuck. Embodiments of the present disclosure are further directed to rotating the wafer and wafer chuck synchronously such that during a given scan there is no relative

emotion between the wafer and the wafer chuck. Such a configuration aids in avoiding scanning errors caused by height variation and vibration of the wafer chuck. It is further noted that the wafer chucking system of the present disclosure may be implemented in a variety of optical measurement contexts, such as, but not limited to, a wafer edge inspection system.

[0012] FIG. 1A illustrates a simplified cross-sectional view of a non-contact wafer chucking system 100, in accordance with one embodiment of the present disclosure. In one embodiment, the wafer chucking system 100 includes a wafer chuck 100 for securing a wafer 104 above the surface of the wafer chuck 102 without making contact with the wafer chuck 102. In another embodiment, the wafer chucking system 100 includes gripper assembly 106. In another embodiment, the wafer chucking system 100 includes a rotational drive unit 116. The rotational drive unit 116 is coupled to the wafer chuck 102 and configured to selectably rotate the wafer chuck 102, the gripper assembly 106 and the wafer 104 during a wafer scanning process.

[0013] In one embodiment, as shown in FIGS. 1A-1B, the wafer chuck 102 includes one or more pressurized gas elements 103. In one embodiment, a pressurized gas element 103 generates an associated pressurized region 107 at or near the output of the respective pressurized gas element 103. The pressurized region 107 serves to provide an upward force on the wafer 104. In this regard, the one or one or more pressurized gas elements 103 may generate one or more pressurized gas regions 107 across a surface of the wafer chuck 102 suitable for elevating the wafer 104 above the surface of the wafer chuck 102. In one embodiment, the wafer chuck 102 may include a plurality of pressurized gas elements 103, as depicted in FIG. 1B. In this regard, the plurality of pressurized gas elements 103 may generate one or more pressurized gas regions 107 distributed across the surface of the wafer chuck suitable for elevating the wafer 104 above the surface of the wafer chuck 102. It is noted herein that the pressurized gas regions 107 are not necessarily formed in a one-to-one correspondence with the pressurized gas elements 103. For example, two

or more gas elements 103 (e.g., gas nozzles, gas channels, multiple gas nozzles, multiple gas channels) may contribute to form a single pressurized gas region 107.

[0014] In one embodiment, the one or more pressurized elements 103 of the wafer chuck 102 form a pressurized air pocket for elevating the wafer 104 above the surface of the wafer chuck 102. In this regard, the one or more pressurized elements 103 may form one or more pressurized air pockets (or other gas), which exerts a net upward force on the bottom of the wafer 104, thereby causing the wafer 104 to stabilize vertically at some location above the wafer chuck 104.

[0015] In another embodiment, as shown in FIGS. 1A-B, the wafer chuck 102 includes one or more vacuum elements 105. In one embodiment, a vacuum element 105 generates an associated reduced pressure, or vacuum, region 109 at or near the input of the respective vacuum gas element 105. For example, the one or more reduced pressure regions 109 may have a pressure that is lower than the one or more pressurized regions 107. The one or more vacuum elements 105 may generate one or more reduced pressure regions 109 across a surface of the wafer chuck 102 suitable for securing the wafer 104 above the surface of the wafer chuck 102 without contact taking place between the wafer 104 and the wafer chuck 102. In this regard, the reduced pressure regions 109 serve to provide a downward force on the wafer 104. The combination of the downward force from the vacuum elements 105 and the upward force from the one or more pressurized gas elements serves to stabilize the vertical position of the wafer 104 at some location above the wafer chuck 102.

[0016] In one embodiment, the wafer chuck 102 may include a plurality of vacuum elements 105, as depicted in FIG. 1B. In this regard, the plurality of vacuum elements 105 may generate one or more reduced pressure regions 109 distributed across the surface of the wafer chuck 102 suitable for securing the wafer 104 above the surface of the wafer chuck 102. It is noted herein that the reduced pressure regions 109 are not necessarily formed in a one-to-one

correspondence with the vacuum elements 105. For example, two or more vacuum elements 105 may contribute to form a single reduced pressure region 109. It is further noted herein that some amount of “cross-flow” may exist between the pressurized gas regions 107 and the reduced pressure regions 109. In this regard, gas from the pressurized gas elements 103 associated with regions 107 may flow to the reduced pressure regions 109 and be evacuated by the vacuum elements 105.

[0017] In one embodiment, the one or more pressurized gas elements 103 include one or more gas nozzles. For example, the one or more pressurized gas elements 103 may include, but are not limited to, one or more gas nozzles configured to direct gas (e.g., air) upward from the surface of the wafer chuck 104 in order to generate the one or more pressurized regions 107. For instance, a pressurized gas nozzle may include, but is not limited to, a bore hole machined out of the surface (or molded/cast into the surface) of the wafer chuck 102, with one or more gas delivery lines fluidically coupled to the hole, which serve to deliver gas (e.g., air) to the hole.

[0018] In one embodiment, the one or more pressurized gas elements 103 include one or more gas channels. For example, the one or more pressurized gas elements 103 may include, but are not limited to, one or more gas channels configured to direct gas (e.g., air) upward from the surface of the wafer chuck 104 in order to generate the one or more pressurized regions 107. For instance, a pressurized gas channel may include, but is not limited to, a recessed region machined out of the surface of the wafer chuck 102, with one or more gas delivery lines fluidically coupled to the recess, which serve to deliver gas (e.g., air) to the recessed channel.

[0019] In one embodiment, the one or more vacuum elements 105 include one or more gas nozzles. For example, the one or more vacuum elements 105 may include, but are not limited to, one or more gas nozzles configured to evacuate gas (e.g., air) downward from the surface of the wafer chuck 104 in order to

generate the one or more reduced pressure regions 109. For instance, a vacuum nozzle may include, but is not limited to, a bore hole machined out of the surface (or molded/cast into the surface) of the wafer chuck 102, with one or more gas delivery lines fluidically coupled to the hole, which serve to evacuate gas (e.g., air) from the region near the hole.

[0020] In one embodiment, the one or more vacuum elements 105 include one or more gas channels. For example, the one or more vacuum elements 105 may include, but are not limited to, one or more gas channels configured to evacuate gas (e.g., air) downward from the surface of the wafer chuck 104 in order to generate the one or more reduced pressure regions 109. For instance, a vacuum gas channel may include, but is not limited to, a recessed region machined out of the surface of the wafer chuck 102, with gas delivery lines fluidically coupled to the recess, which serve to evacuate gas (e.g., air) from the region near the recessed channel.

[0021] In one embodiment, as shown in FIG. 1B, at least a portion of the vacuum elements 105 are interleaved with a portion pressurized gas elements 103. In this regard, one or more vacuum elements 105 may be arranged so as to alternate with one or more of the pressurized gas elements 103. It is recognized herein that the pressurized gas elements 103 and the vacuum gas elements 105 may be arranged in any pattern across the surface of the wafer chuck 102. For example, the pressurized gas elements 103 and the vacuum gas element 105 may be arranged in any geometric pattern (or patterns) known in the art.

[0022] For instance, the pressurized gas elements 103 and the vacuum gas elements 105 may be arranged in a linear grid, where one or more vacuum elements 105 are alternated, as function of X-Y position, with one or more pressurized gas elements 103. In another instance, the pressurized gas elements 103 and the vacuum gas elements 105 may be arranged in a circular grid, where one or more vacuum gas elements 105 are alternated, as a function of angular position about the wafer chuck 102, with the one or more pressurized

gas elements 103. In another instance, the pressurized gas elements 103 and the vacuum elements 105 may be arranged in a concentric radial grid, where concentric rings of one or more vacuum gas elements 105 are alternated, as a function of radial position on the wafer chuck 102, with concentric rings of one or more pressurized gas elements 103.

[0023] FIG. 1C illustrates an arrangement of pressurized gas elements 103 and vacuum elements 105, in accordance with one embodiment of the present disclosure. In one embodiment, the wafer chuck 102 includes multiple sets 122 of pressurized gas elements 103. In another embodiment, the wafer chuck 102 includes multiple sets 124 of vacuum gas elements 105. As shown in FIG. 1C, the sets 122 of pressurized gas elements 103 may be interleaved with the sets 124 of vacuum elements 105. It is noted herein that the arrangement depicted in FIG. 1C is not limiting and is provided merely for illustrative purposes. It is again recognized that the pressurized gas elements (or sets of pressurized gas elements) and the vacuum elements (or sets of pressurized gas elements) may be arranged across the surface of the wafer chuck in any suitable pattern.

[0024] It is noted herein that the one or more pressurized gas elements 103 may be in fluidic communication with a gas delivery system and/or network (not shown). In this regard, a gas source may be coupled to the delivery system/network, with gas being delivered to the pressurized gas elements 103 via the delivery system/network. In one embodiment, the delivery system/network may include one or more gas pumps for pumping gas, such as air, to the pressurized gas elements 103. In another embodiment, the delivery system/network may include one or more gas filters, such as an air filter, in order to filter the given gas prior to it being outputted through the pressurized gas elements 103. It is further noted herein that the one or more vacuum elements 105 may be in fluidic communication with a vacuum system and/or network (not shown). In this regard, a gas pump may be fluidically coupled to the vacuum elements 105 and configured to evacuate gas through the vacuum elements 105 and to an external reservoir (e.g., gas container, ambient atmosphere and the

like). Those skilled in the art should recognize that there are a variety of gas delivery and gas vacuum mechanisms suitable for implementation in the system 100 of the present disclosure.

[0025] FIG. 1D illustrates a schematic bottom view of the wafer chuck 102 and gripper assembly 106, in accordance with one or more embodiments of the present disclosure. As shown in FIG. 1D, the gripper elements 108 of the gripper assembly 106 act to laterally secure the wafer 104. Further, the cam unit 114 is mechanically coupled to the wafer chuck 102 and is used to drive the motion of the gripper elements 108 in securing the wafer 104. Once secure, the gripper elements of the gripper assembly 106 rotate the wafer 104 synchronously with the wafer chuck 102 as the wafer chuck 102 is rotated by the rotation drive unit 114 (not shown in FIG. 1D). FIG. 1E illustrates a schematic top view of the wafer chuck 102 securing the wafer 104, in accordance with one or more embodiments of the present disclosure. As shown in FIG. 1E, the wafer chuck 102 may include a set rows, aligned radially, of pressurized gas elements 103. In addition, the wafer chuck 102 may include a set of rows, aligned radially, of vacuum elements 105.

[0026] Referring again to FIG. 1A, in one embodiment, the gripper assembly 106 is mechanically coupled to a portion the wafer chuck 102. In one embodiment, the gripper assembly 106 is reversibly couplable to one or more edge portions of the wafer 104. In this regard, the gripper assembly 106 may laterally secure the wafer 104. For example, as shown in FIG. 1A, the gripper assembly 106 may serve to secure the wafer 104 along the horizontal direction without applying a significant contact force in the vertical direction. In another embodiment, the gripper assembly 106 may laterally and rotationally secure (relative to the wafer chuck 102) the wafer 104 such that when the wafer chuck 102 and the gripper assembly 106 are rotated by the rotational drive unit 116 the wafer 104 is also rotated. In this regard, while the wafer 104 rotates relative to an outside reference frame, the wafer 104 does not move significantly with respect to the surface of the wafer chuck 102 during a wafer scanning process.

[0027] In another embodiment, the gripper assembly 106 may serve to adjust the lateral position of the wafer 104 in order to substantially center the wafer 104 prior to rotation of the wafer 104 during a scanning process.

[0028] In one embodiment, the gripper assembly 106 of the wafer chucking system 100 includes one or more gripper elements 108. In another embodiment, the gripper elements 108 of the gripper assembly 106 include one or more connection arms, or rods, 110 and one or more gripper heads 112. In another embodiment, the one or more gripper heads 112 may include any mechanism known in the art suitable for securing the wafer 104. For example, the one or more gripper heads 112 may include, but is not limited to, a spring loaded device for securing the wafer. By way of another example, the one or more gripper heads 112 may include, but is not limited to, a frictional portion configured to secure the wafer 104 via friction.

[0029] In one embodiment, the gripper assembly 106 may include, but is not limited to, two or more gripper elements 108 (e.g., 2, 3, 4, 5 and so on). For example, as shown in FIG. 1D and 1E, the gripper assembly 106 may include three gripper elements 108. In another instance, although not shown, the gripper assembly 106 may include four gripper elements 108.

[0030] In another embodiment, the gripper assembly 106 includes a cam unit 114. In one embodiment, the cam unit 114 is mechanically coupled to the gripper assembly 106. In one embodiment, as shown in FIGS. 1F and 1G, the cam unit is configured to drive the linear motion of one or more gripper elements 108 of the gripper assembly 106. In this regard, the cam unit 114 may selectively engage and/or disengage the gripper elements 108 with one or more portions of the wafer 104. For example, as shown in FIG. 1F, the cam unit 114 may cause the gripper elements 108 to move into an expanded, or disengaged, state. Such a configuration allows for a user (or robotic arm) to load a wafer 104 onto the wafer chuck 102 prior to a rotational scanning process. In addition, the cam unit 114 may be placed in a disengaged state when the user or robotic arm (not

shown) unloads the wafer 104 from the chuck 102. By way of further example, as shown in FIG. 1G, the cam unit 114 may cause the gripper elements 108 to move into a retracted, or engaged state. Such a configuration serves to laterally secure the wafer 102, while the chuck 102 secures the wafer above the chuck 102, during a rotational scanning process.

[0031] Referring again to FIG. 1A, the wafer chuck 102 (and the connected gripper assembly 106) are supported by a shaft 116, or spindle, of the rotational drive unit 117. For example, the shaft 117 may be connected to a motor 119. In this regard, the motor 119 may be configured to rotate the shaft 117 at a selected rotational velocity, thereby rotating the wafer chuck 102, the gripper assembly 106 and the wafer 104 about an axis perpendicular to the surface of the wafer chuck 102. For instance, the wafer chuck 102, the gripper assembly 106 and the wafer 104 may be rotated at speeds greater than 1,000 revolutions per minute (rpm) (e.g., 1,000 to 10,000 rpm).

[0032] FIGS. 2A and 2B illustrate high-level block diagram views of inspection systems 200, 210 equipped with the non-contact wafer chucking system 100, in accordance with one or more embodiments of the present disclosure. In one embodiment, the wafer inspection systems 200, 210 of the present disclosure may include the non-contact wafer chucking system 100, as described previously herein. In one embodiment, the inspection systems 200, 210 further include least one light source 202 (e.g., one or more lasers, one or more broadband light sources and etc.) configured to illuminate an area on the surface of the wafer 104. In another embodiment, the inspection systems 200, 210 include one or more detectors 204, or cameras, suitable for detecting light reflected, diffracted or scattered from the area illuminated by the light source 202. In one embodiment, the one or more detectors 204 may include, but are not limited to, a CCD or TDI-CCD detector, or a photomultiplier detector. In addition, the inspection systems 200, 210 may include a set of optical elements (e.g., illumination optics, collection optics, beam splitters 206, filters and the like) configured for directing (and focusing) illumination from the light source 202 onto

the surface of the wafer 104 and, in turn, directing illumination from the surface of the wafer 104 to the imaging portion of the detector 204 of the inspection systems 200, 210. For instance, the set of optical elements for the systems 200, 210 may include, but is not limited to, a primary imaging lens suitable for imaging the illuminated area of the wafer onto a collection portion(s) of the detector 204. Further, the imaging detector 204 may be communicatively coupled to an image processing computer which may identify and store imagery data acquired from the detector 204.

[0033] The inspection systems 200, 210 of the present disclosure may be configured as any inspection system known in the art. For example, as shown in FIG. 2A, the inspection system 200 of the present invention may be configured as a bright field (BF) inspection system. Alternatively, as shown in FIG. 2B, the inspection system 210 may be configured as a dark field (DF) inspection system. Applicant notes that the optical configurations depicted in FIGS. 2A and 2B are provided merely for illustrative purposes and should not be interpreted as limiting. In a general sense, the inspection systems 200, 210 of the present disclosure may include any set of imaging and optical elements suitable for imaging the surface of the wafer 104. Examples of wafer inspection tools are described in detail in U.S. Pat. No. 7,092,082, U.S. Pat. No. 6,702,302, U.S. Pat. No. 6,621,570 and U.S. Pat. No. 5,805,278, which are each herein incorporated by reference.

[0034] FIG. 3 illustrate high-level block diagram views of an edge inspection 300 equipped with the non-contact wafer chucking system 100, in accordance with one or more embodiments of the present disclosure. For purposes of clarity, the gripper assembly 106 is not depicted in FIG. 3, even though it is recognized herein that the gripper assembly 106 is present in such an edge inspection setting. As shown in FIG. 3, an edge inspection system 300 may include a detector 304 suitable for collecting imagery data from the edge region 302 of the wafer 104. It is further recognized that the inspection system 300 allows for various portions of the edge 302 to be inspected using the detector 304. For

example, as shown in FIG. 3, the detector 304 may collect imagery data at a location A at the top portion of the edge 302 of the wafer 104 (e.g., top portion of wafer bevel). By way of another example, as shown in FIG. 3, the detector 304 may collect imagery data at a location B at the center portion of the edge 302 of the wafer 104 (e.g., center of wafer bevel). By way of another example, as shown in FIG. 3, the detector 304 may collect imagery data at a location C at the bottom portion of the edge 302 of the wafer 104 (e.g., bottom portion of wafer bevel).

[0035] FIG 4 illustrates a flow diagram depicting the steps of a method 400 for non-contact chucking of a wafer, in accordance with one or more embodiments of the present disclosure. In step 402, one or more pressurized gas regions are generated across a surface of a wafer chuck in order to elevate the wafer above the surface of the wafer chuck. In step 404, one or more reduced pressure regions are generated across the surface of the wafer chuck in order to secure the wafer above the wafer chuck without contact to the wafer chuck. In step 406, one or more gripper elements are reversibly coupled, or attached, to an edge portion of the wafer in order to rotationally secure the wafer with respect to the wafer chuck. In step 408, the wafer, the plurality of gripper elements and the wafer chuck are synchronously rotated at a selected rotational velocity.

[0036] The herein described subject matter sometimes illustrates different components contained within, or connected with, other components. It is to be understood that such depicted architectures are merely exemplary, and that in fact many other architectures can be implemented which achieve the same functionality. In a conceptual sense, any arrangement of components to achieve the same functionality is effectively "associated" such that the desired functionality is achieved. Hence, any two components herein combined to achieve a particular functionality can be seen as "associated with" each other such that the desired functionality is achieved, irrespective of architectures or intermedial components. Likewise, any two components so associated can also be viewed as being "connected", or "coupled", to each other to achieve the

desired functionality, and any two components capable of being so associated can also be viewed as being "couplable", to each other to achieve the desired functionality. Specific examples of couplable include but are not limited to physically mateable and/or physically interacting components and/or wirelessly interactable and/or wirelessly interacting components and/or logically interacting and/or logically interactable components.

[0037] It is believed that the present disclosure and many of its attendant advantages will be understood by the foregoing description, and it will be apparent that various changes may be made in the form, construction and arrangement of the components without departing from the disclosed subject matter or without sacrificing all of its material advantages. The form described is merely explanatory, and it is the intention of the following claims to encompass and include such changes. Furthermore, it is to be understood that the invention is defined by the appended claims.

What is claimed:

1. An apparatus for non-contact chucking of a wafer comprising:
 - a wafer chuck, the wafer chuck including one or more pressurized gas elements configured to generate one or more pressurized gas regions across a surface of the wafer chuck suitable for elevating the wafer above the surface of the wafer chuck, the wafer chuck further including one or more vacuum elements configured to generate one or more reduced pressure regions across the surface of the wafer chuck, the reduced pressure regions having a pressure lower than the pressurized gas regions, the one or more reduced pressure regions suitable for securing the wafer above the wafer chuck without contact to the wafer chuck;
 - a gripper assembly coupled to a portion of the wafer chuck; and
 - a rotational drive unit mechanically coupled to the wafer chuck,wherein the rotational drive unit is configured to selectively rotate the wafer chuck,
 - wherein the gripper assembly is reversibly couplable to one or more edge portions of the wafer so as to laterally secure the wafer such that the wafer and the gripper assembly rotate synchronously with the wafer chuck during rotation of the wafer chuck by the rotational drive unit.
2. The apparatus of claim 1, wherein the one or more pressurized gas elements comprise:
 - one or more pressurized gas nozzles configured to direct gas upward from the surface of the wafer chuck in order to generate the one or more pressurized regions.
3. The apparatus of claim 1, wherein the one or more pressurized gas elements comprise:
 - one or more pressurized gas channels configured to direct gas upward from the surface of the wafer chuck in order to generate the one or more pressurized regions.

4. The apparatus of claim 1, wherein the one or more pressurized elements of the wafer chuck form a pressurized air pocket for elevating the wafer above the surface of the wafer chuck.

5. The apparatus of claim 1, wherein the one or more vacuum elements comprise:

one or more vacuum nozzles configured to evacuate gas from the surface of the wafer chuck in order to generate the one or more reduced pressure regions.

6. The apparatus of claim 1, wherein the one or more vacuum elements comprise:

one or more vacuum channels configured to evacuate gas from the surface of the wafer chuck in order to generate the one or more reduced pressure regions.

7. The apparatus of claim 1, wherein the one or more pressurized gas elements comprise:

a plurality of pressurized gas elements.

8. The apparatus of claim 7, wherein the one or more vacuum elements comprise:

a plurality of vacuum elements.

9. The apparatus of claim 8, wherein at least some of the plurality of vacuum elements are interleaved with at least some of the plurality of pressurized gas elements.

10. The apparatus of claim 1, wherein the one or more pressurized gas elements comprise:
 - a plurality of sets of pressurized gas elements.
11. The apparatus of claim 10, wherein the one or more vacuum elements comprise:
 - a plurality of sets of vacuum elements.
12. The apparatus of claim 11, wherein at least some of the plurality of sets of vacuum elements are interleaved with at least some of the plurality of sets of pressurized gas elements.
13. The apparatus of claim 1, wherein the one or more pressurized regions are proximate to the one or more reduced pressure regions.
14. The apparatus of claim 1, wherein the one or more pressurized regions are adjacent to the one or more reduced pressure regions.
15. The apparatus of claim 1, wherein the one or more pressurized regions alternate with the one or more reduced pressure regions.
16. The apparatus of claim 1, wherein the gripper assembly comprises:
 - a plurality of gripper elements.
17. The apparatus of claim 16, wherein the plurality of gripper elements comprises:
 - three or more gripper elements.
18. The apparatus of claim 16, wherein at least some of the gripper elements are couplable to an edge portion of the wafer.

19. The apparatus of claim 1, wherein the gripper assembly includes a cam unit coupled to the gripper assembly, wherein the cam unit is configured to drive the linear motion of one or more gripper elements of the gripper assembly.
20. The apparatus of claim 1, wherein the gripper assembly is configured to selectably engage the edge portion of the wafer.
21. The shielding apparatus of claim 1, wherein the gripper assembly is configured to selectably disengage from the edge portion of the wafer.
22. The apparatus of claim 1, wherein the gripper assembly is configured to laterally position the wafer on the wafer chuck.
23. The apparatus of claim 1, wherein the rotational drive unit comprises:
 - a spindle; and
 - a motor.
24. The apparatus of claim 1, wherein the wafer comprises:
 - a semiconductor wafer.
25. An optical system comprising:
 - a wafer chucking sub-system including:
 - a wafer chuck, the wafer chuck including one or more pressurized gas elements configured to generate one or more pressurized gas regions across a surface of the wafer chuck suitable for elevating the wafer above the surface of the wafer chuck, the wafer chuck further including one or more vacuum elements configured to generate one or more reduced pressure regions across the surface of the wafer chuck, the reduced pressure regions having a pressure lower

than the pressurized gas regions, the one or more reduced pressure regions suitable for securing the wafer above the wafer chuck without contact to the wafer chuck;

a gripper assembly coupled to a portion of the wafer chuck; and

a rotational drive unit mechanically coupled to the wafer chuck, wherein the rotational drive unit is configured to selectively rotate the wafer chuck, wherein the gripper assembly is reversibly couplable to one or more edge portions of the wafer so as to laterally secure the wafer such that the wafer and the gripper assembly rotate synchronously with the wafer chuck during rotation of the wafer chuck by the rotational drive unit; and

an illumination source configured to illuminate one or more portions of the wafer secured by the wafer chucking sub-system; and

a detector configured to collect illumination from the illuminated one or more portions of the wafer.

26. The optical system of claim 25, wherein the optical system is configured as an inspection tool.

27. The optical system of claim 26, wherein the optical system is configured as a wafer edge inspection tool.

28. The optical system of claim 26, wherein the optical system is configured as at least one of a brightfield inspection tool or a darkfield inspection tool.

29. The optical system of claim 25, wherein the optical system is configured as a metrology tool.

30. The optical system of claim 25, wherein the one or more pressurized gas elements comprise:

one or more pressurized gas nozzles configured to direct gas upward from the surface of the wafer chuck in order to generate the one or more pressurized regions.

31. The optical system of claim 25, wherein the one or more pressurized gas elements comprise:

one or more pressurized gas channels configured to direct gas upward from the surface of the wafer chuck in order to generate the one or more pressurized regions.

32. The optical system of claim 25, wherein the one or more vacuum elements comprise:

one or more vacuum nozzles configured to evacuate gas from the surface of the wafer chuck in order to generate the one or more reduced pressure regions.

33. The optical system of claim 25, wherein the one or more vacuum elements comprise:

one or more vacuum channels configured to evacuate gas from the surface of the wafer chuck in order to generate the one or more reduced pressure regions.

34. The optical system of claim 25, wherein the one or more pressurized gas elements comprise:

a plurality of pressurized gas elements.

35. The optical system of claim 25, wherein the one or more vacuum elements comprise:

a plurality of vacuum elements.

36. The optical system of claim 25, wherein the gripper assembly comprises:
a plurality of gripper elements.

37. The optical system of claim 36, wherein the plurality of gripper elements comprises:

three or more gripper elements.

38. The optical system of claim 36, wherein at least some of the gripper elements are couplable to an edge portion of the wafer.

39. The optical system of claim 25, wherein the gripper assembly includes a cam unit coupled to the gripper assembly, wherein the cam unit is configured to drive the linear motion of one or more gripper elements of the gripper assembly.

40. The optical system of claim 25, wherein the gripper assembly is configured to selectably engage the edge portion of the wafer.

41. The optical system of claim 25, wherein the gripper assembly is configured to selectably disengage from the edge portion of the wafer.

42. The optical system of claim 25, wherein the gripper assembly is configured to laterally position the wafer on the wafer chuck.

43. A method for non-contact chucking of a wafer comprising:
- generating one or more pressurized gas regions across a surface of a wafer chuck in order to elevate the wafer above the surface of the wafer chuck;
 - generating one or more reduced pressure regions across the surface of the wafer chuck in order to secure the wafer above the wafer chuck without contact to the wafer chuck;
 - reversibly coupling a gripper assembly to an edge portion of the wafer in order to rotationally secure the wafer with respect to the wafer chuck; and
 - synchronously rotating the wafer, gripper assembly and the wafer chuck at a selected rotational velocity.

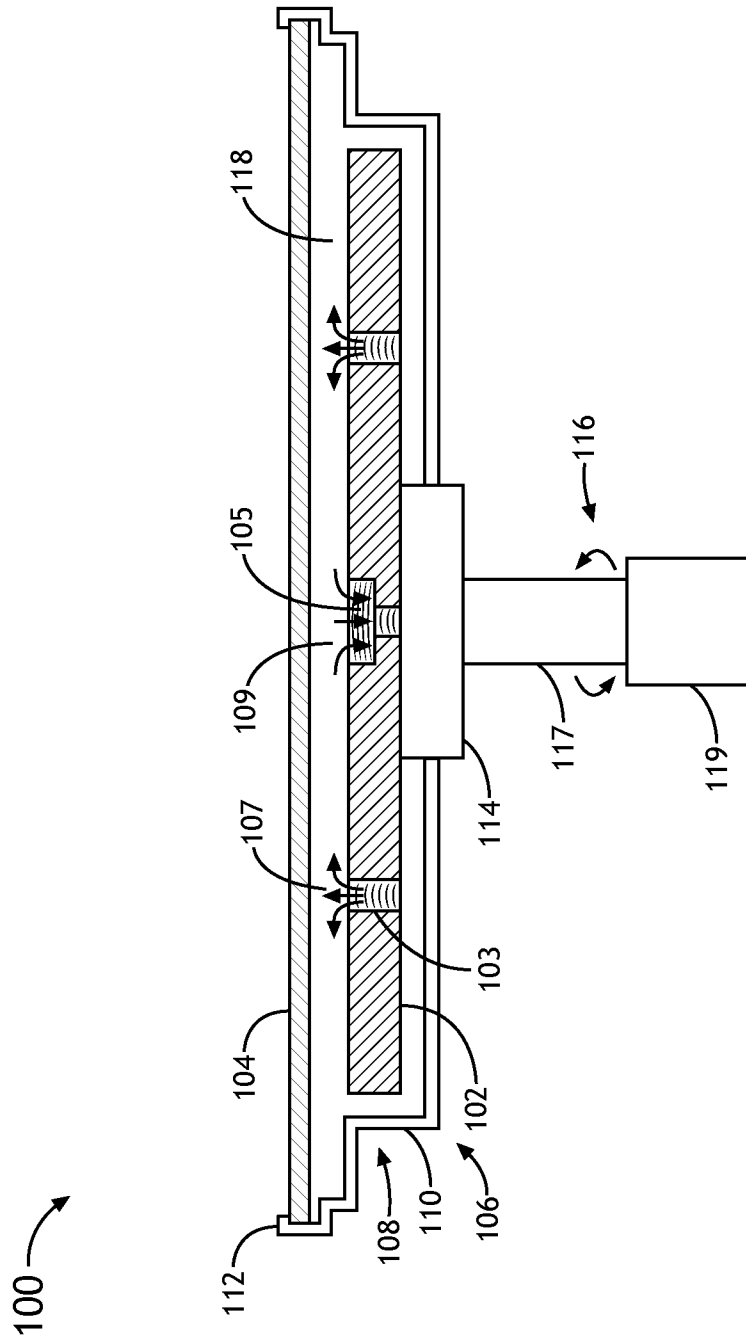

FIG.1A

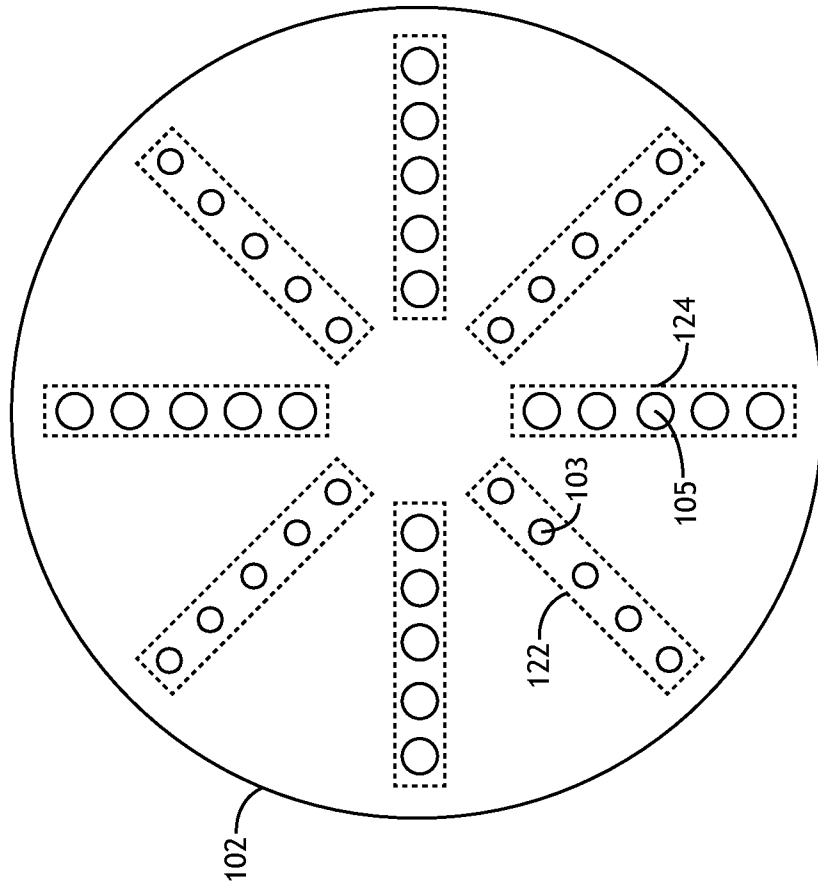

FIG. 1C

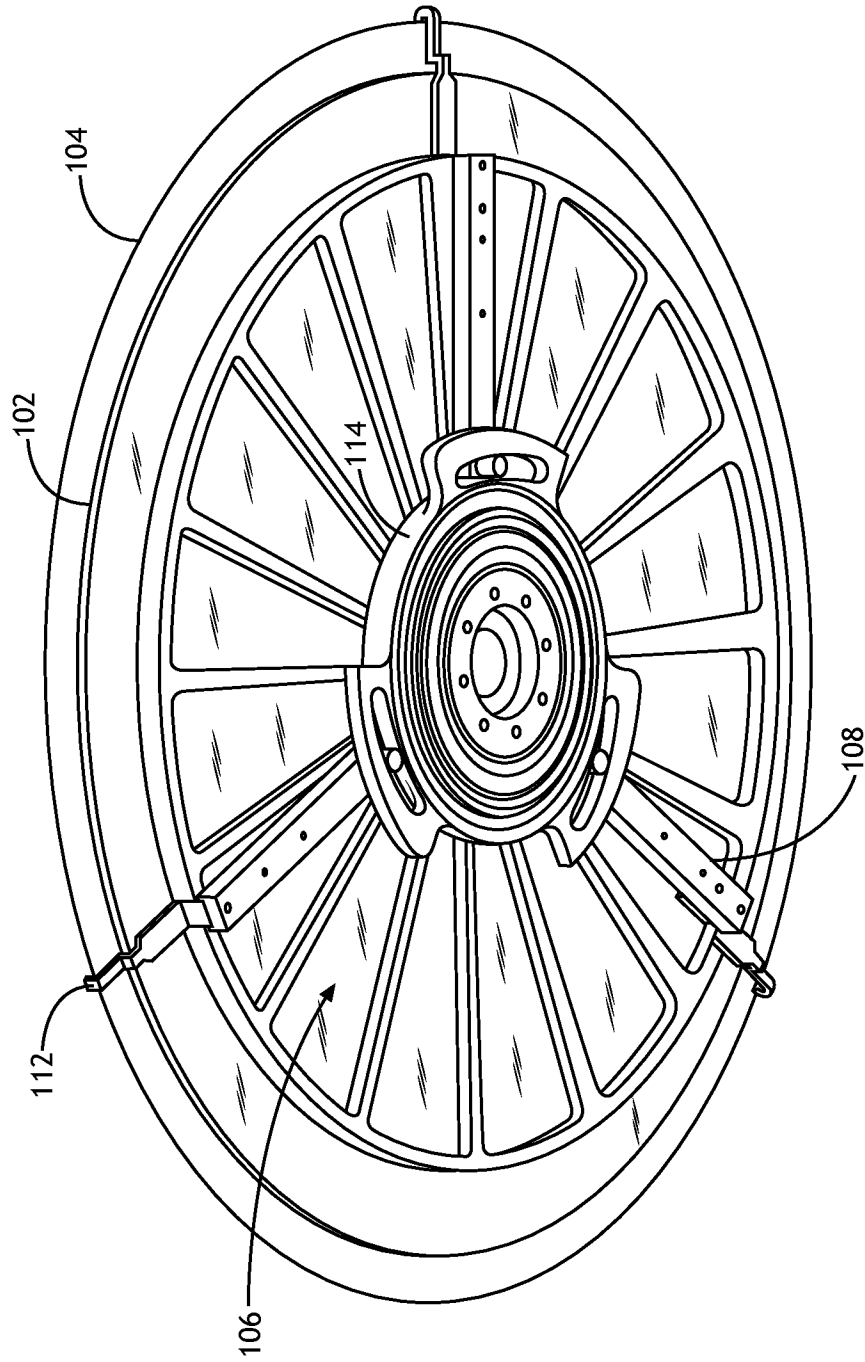

FIG. 1D

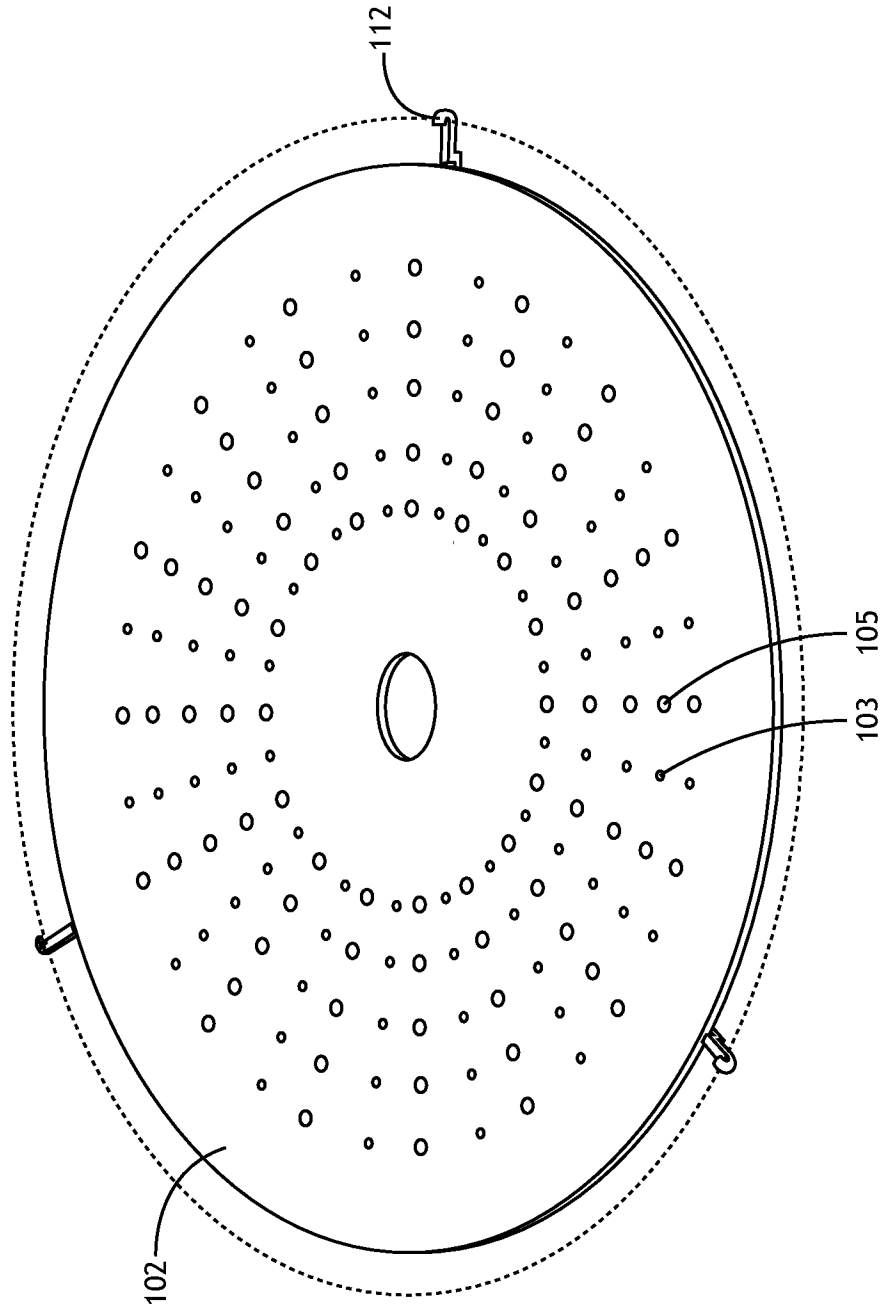

FIG. 1E

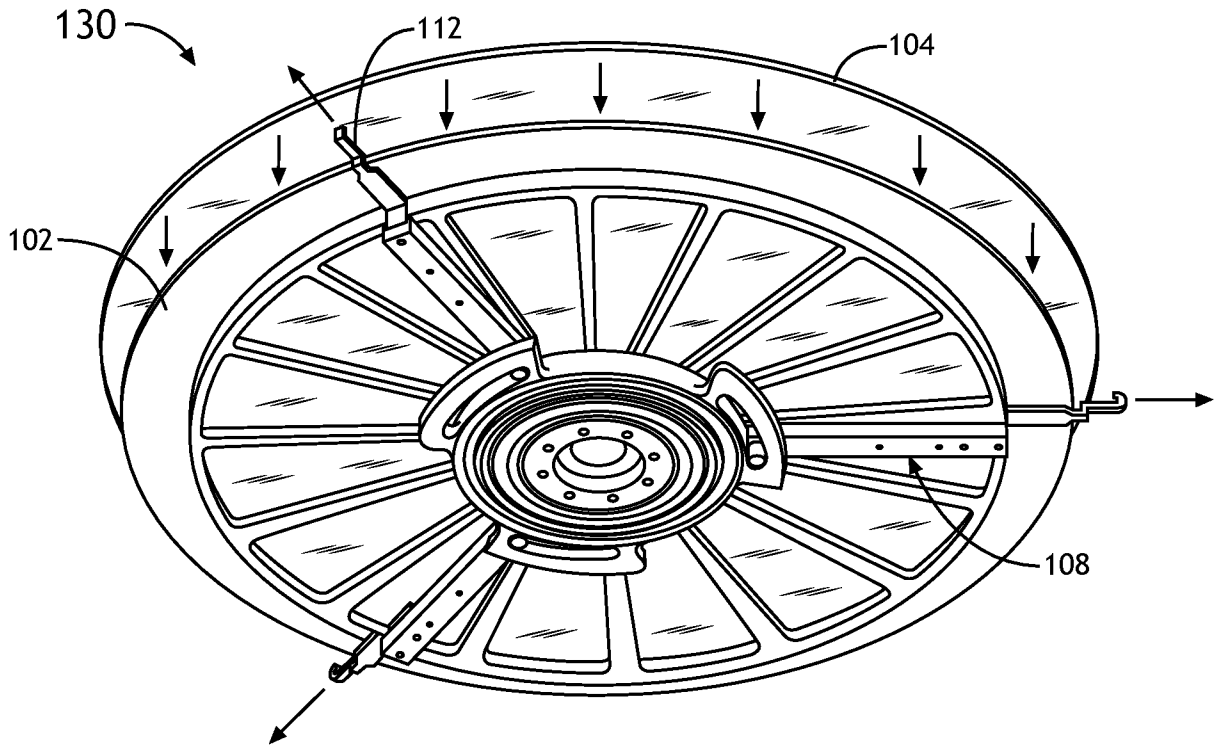

FIG. 1F

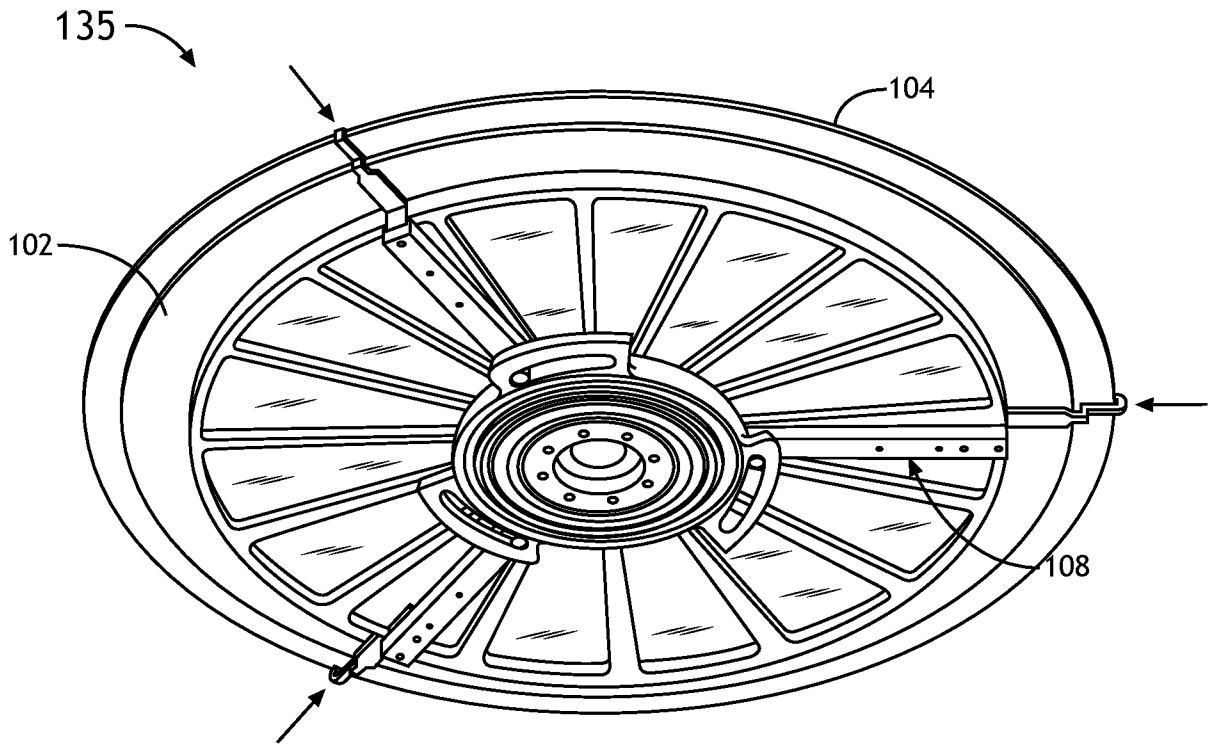

FIG. 1G

7/9

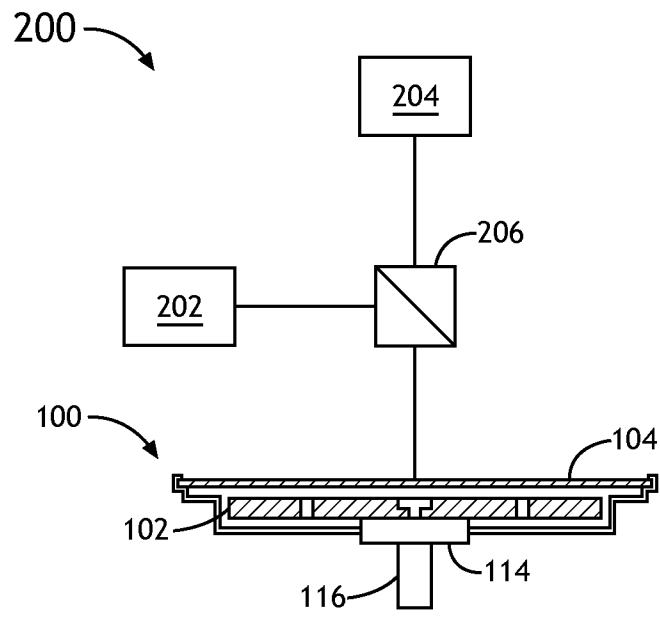

FIG. 2A

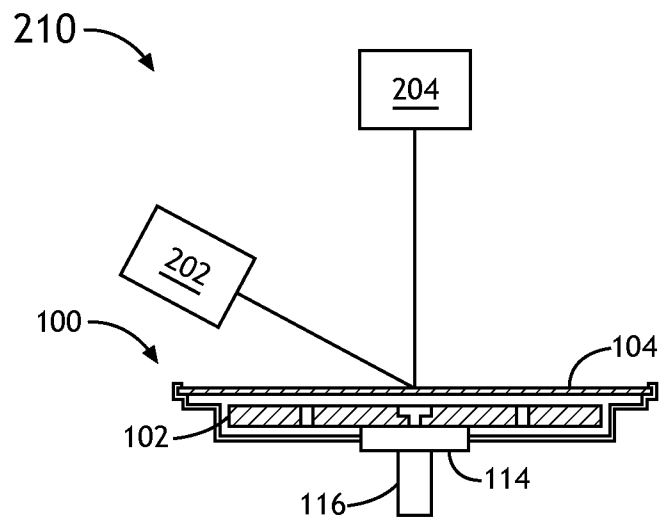

FIG. 2B

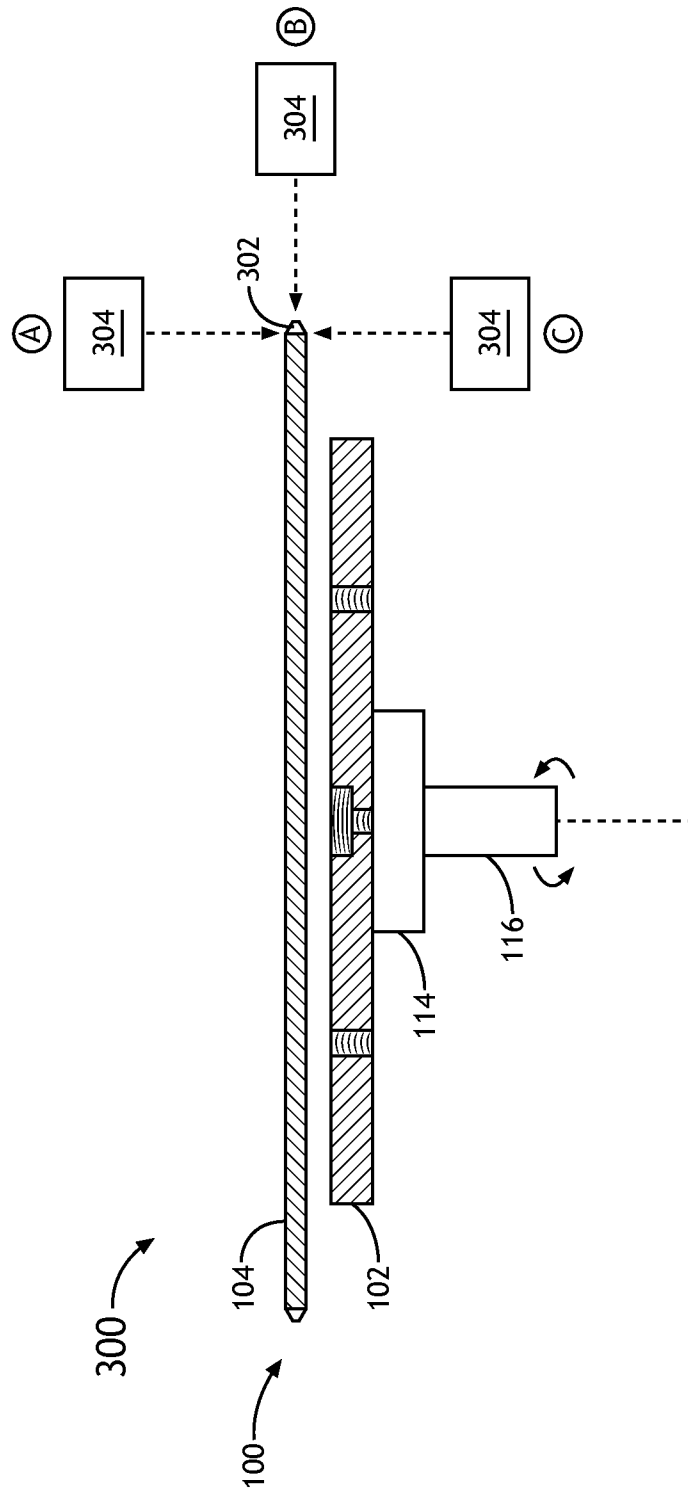

FIG.3

9/9

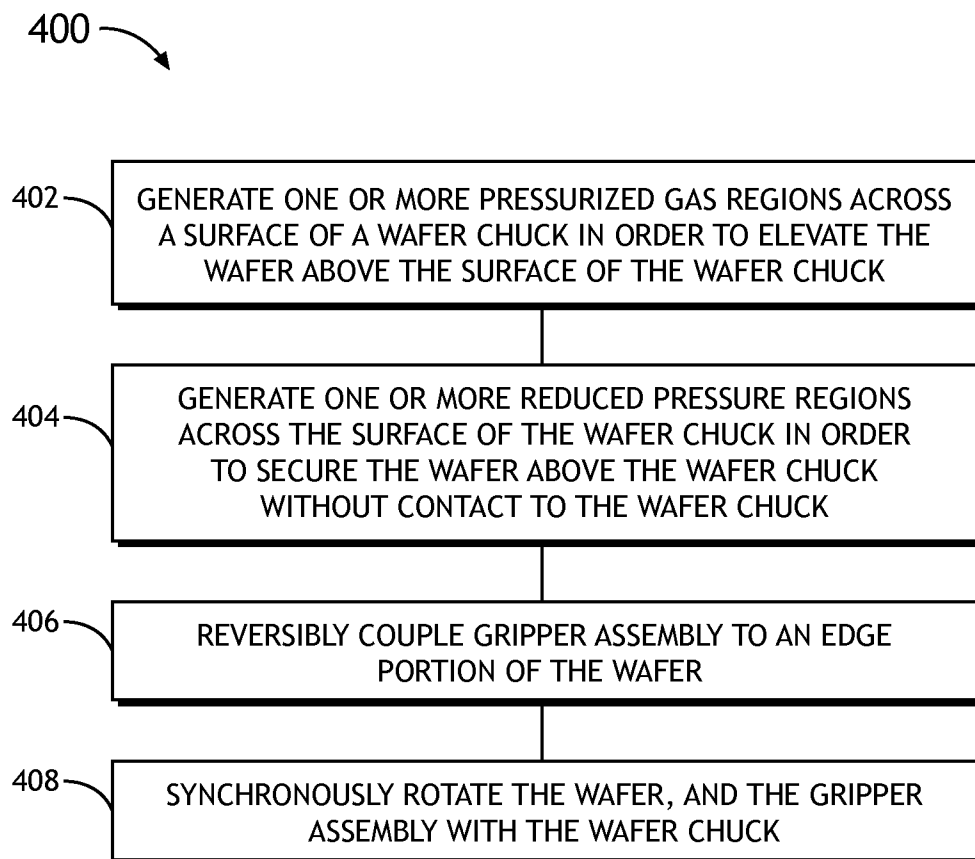

FIG.4

A. CLASSIFICATION OF SUBJECT MATTER**H01L 21/683(2006.01)i, H02N 13/00(2006.01)i, B23Q 3/15(2006.01)i**

According to International Patent Classification (IPC) or to both national classification and IPC

B. FIELDS SEARCHED

Minimum documentation searched (classification system followed by classification symbols)

H01L 21/683; H01L 21/306; H01L 21/687; H01L 21/30; G01N 21/00; G01N 21/956; B25B 11/00; H01L 21/76; H02N 13/00; B23Q 3/15

Documentation searched other than minimum documentation to the extent that such documents are included in the fields searched

Korean utility models and applications for utility models
Japanese utility models and applications for utility models

Electronic data base consulted during the international search (name of data base and, where practicable, search terms used)

eKOMPASS(KIPO internal) & keywords: wafer, chuck, air, pressurized gas, non-contact, grip, rotation, and illumination

C. DOCUMENTS CONSIDERED TO BE RELEVANT

Category*	Citation of document, with indication, where appropriate, of the relevant passages	Relevant to claim No.
Y	US 2013-0309874 A1 (KINOSHITA et al.) 21 November 2013 See abstract, paragraphs [0035]-[0038],[0043]-[0044] and figure 1.	1-43
Y	US 2008-0229811 A1 (ZHAO et al.) 25 September 2008 See abstract, paragraphs [0017],[0022], and figures 1,2A.	1-43
Y	US 2011-0069313 A1 (SAKAI et al.) 24 March 2011 See abstract, paragraphs [0088]-[0090], and figure 11.	25-42
A	US 2010-0001449 A1 (SIEBERT et al.) 07 January 2010 See abstract, paragraphs [0036]-[0039], and figure 1.	1-43
A	US 7682933 B1 (LOOMIS, ANDREW H.) 23 March 2010 See abstract, column 3, lines 21-60, and figure 4.	1-43

 Further documents are listed in the continuation of Box C. See patent family annex.

* Special categories of cited documents:

"A" document defining the general state of the art which is not considered to be of particular relevance

"E" earlier application or patent but published on or after the international filing date

"L" document which may throw doubts on priority claim(s) or which is cited to establish the publication date of another citation or other special reason (as specified)

"O" document referring to an oral disclosure, use, exhibition or other means

"P" document published prior to the international filing date but later than the priority date claimed

"T" later document published after the international filing date or priority date and not in conflict with the application but cited to understand the principle or theory underlying the invention

"X" document of particular relevance; the claimed invention cannot be considered novel or cannot be considered to involve an inventive step when the document is taken alone

"Y" document of particular relevance; the claimed invention cannot be considered to involve an inventive step when the document is combined with one or more other such documents, such combination being obvious to a person skilled in the art

"&" document member of the same patent family

Date of the actual completion of the international search

06 April 2015 (06.04.2015)

Date of mailing of the international search report

13 April 2015 (13.04.2015)

Name and mailing address of the ISA/KR

International Application Division
Korean Intellectual Property Office
189 Cheongsa-ro, Seo-gu, Daejeon Metropolitan City, 302-701,
Republic of Korea

Facsimile No. ++82 42 472 7140

Authorized officer

LEE, Jong Kyung

Telephone No. +82-42-481-3360



INTERNATIONAL SEARCH REPORT

Information on patent family members

International application No.

PCT/US2014/071478

Patent document cited in search report	Publication date	Patent family member(s)	Publication date
US 2013-0309874 A1	21/11/2013	KR 10-2013-0127946 A TW 201409560 A US 2014-0349489 A1	25/11/2013 01/03/2014 27/11/2014
US 2008-0229811 A1	25/09/2008	JP 05579452 B2 JP 2010-522431 A US 7607647 B2 WO 2008-121561 A1	27/08/2014 01/07/2010 27/10/2009 09/10/2008
US 2011-0069313 A1	24/03/2011	CN 102037348 A CN 102037348 B EP 2287594 A1 HK 1155805 A1 JP 05007979 B2 JP 2009-281846 A KR 10-1240860 B1 KR 10-2011-0000583 A US 8599379 B2 WO 2009-142305 A1	27/04/2011 06/11/2013 23/02/2011 11/04/2014 22/08/2012 03/12/2009 07/03/2013 03/01/2011 03/12/2013 26/11/2009
US 2010-0001449 A1	07/01/2010	DE 102006045866 A1 DE 102006045866 B4 US 8444126 B2 WO 2008-037791 A1	03/04/2008 12/08/2010 21/05/2013 03/04/2008
US 7682933 B1	23/03/2010	None	