

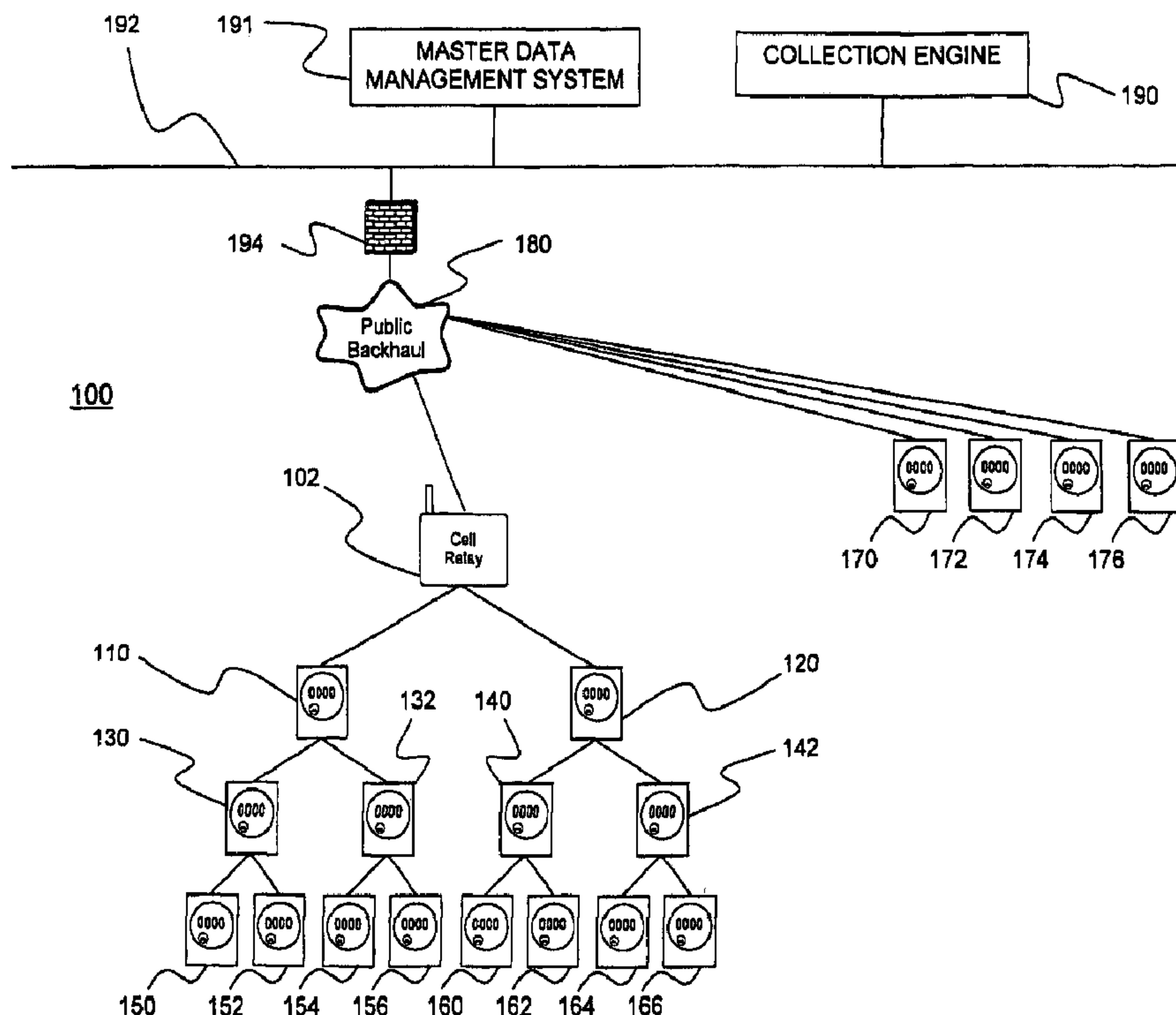

(86) **Date de dépôt PCT/PCT Filing Date:** 2007/09/04  
 (87) **Date publication PCT/PCT Publication Date:** 2008/03/13  
 (45) **Date de délivrance/Issue Date:** 2017/02/28  
 (85) **Entrée phase nationale/National Entry:** 2009/02/27  
 (86) **N° demande PCT/PCT Application No.:** US 2007/019268  
 (87) **N° publication PCT/PCT Publication No.:** 2008/030416  
 (30) **Priorités/Priorities:** 2006/09/05 (US60/842,269);  
 2007/08/31 (US11/897,956)

(51) **Cl.Int./Int.Cl. G01R 22/00** (2006.01),  
**G01R 21/06** (2006.01), **H04W 84/18** (2009.01)  
 (72) **Inventeurs/Inventors:**  
 MAKINSON, DAVID, US;  
 LANCASTER, ANDREW, US;  
 SWANSON, SCOTT, US  
 (73) **Propriétaire/Owner:**  
 ITRON, INC., US  
 (74) **Agent:** SMART & BIGGAR

(54) **Titre : DETECTION DE TENSION COTE CHARGE POUR UNE METROLOGIE AMI**  
 (54) **Title: LOAD SIDE VOLTAGE SENSING FOR AMI METROLOGY**



(57) **Abrégé/Abstract:**

Disclosed are apparatus and methodology subject matters for providing improved functionality of a meter in a 2-way communications arrangement, such as an Advanced Metering System (AMS) or Infrastructure (AMI) More particularly, the present

**(57) Abrégé(suite)/Abstract(continued):**

technology relates methodologies and apparatus for providing load side voltage sensing for utility meters which preferably are operable with remote disconnect features in an Advanced Metering Infrastructure (AMI) open operational framework. The present subject matter provides enhanced capabilities resulting in improved functionality, increased safety, and greater economy vis-a-vis fraud detection for individual metrology components in an open operational framework. Meters per the present subject matter utilize a detection circuit, which is situated generally downstream of a remote disconnect functionality. Such detection circuit is able to sense whether voltage exists or doesn't exist at such relatively downstream, or load side location.

(12) INTERNATIONAL APPLICATION PUBLISHED UNDER THE PATENT COOPERATION TREATY (PCT)

(19) World Intellectual Property Organization  
International Bureau



(43) International Publication Date  
13 March 2008 (13.03.2008)

PCT

(10) International Publication Number  
**WO 2008/030416 A3**

- (51) International Patent Classification:  
**G01R 11/32** (2006.01)
- (21) International Application Number:  
PCT/US2007/019268
- (22) International Filing Date:  
4 September 2007 (04.09.2007)
- (25) Filing Language: English
- (26) Publication Language: English
- (30) Priority Data:  
60/842,269 5 September 2006 (05.09.2006) US  
11/897,956 31 August 2007 (31.08.2007) US
- (71) Applicant (for all designated States except US): **ITRON, INC.** [US/US]; 2111 N. Molter Road, Liberty Lake, Washington 99019 (US).
- (72) Inventors; and
- (75) Inventors/Applicants (for US only): **MAKINSON, David** [US/US]; 104 Pinewood Drive, Seneca, South Carolina 29678 (US). **LANCASTER, Andrew** [US/US]; 503 Westbrook Drive, Seneca, South Carolina 29672 (US). **SWANSON, Scott** [US/US]; 1445 Sutton Farm Road, Hiawassee, Georgia 30546 (US).
- (74) Agent: **MOOSE, Richard M.**; Dority & Manning, Attorneys At Law, P.A., P. O. Box 1449, Greenville, South Carolina 29602-1449 (US).

- (81) Designated States (unless otherwise indicated, for every kind of national protection available): AE, AG, AL, AM, AT, AU, AZ, BA, BB, BG, BH, BR, BW, BY, BZ, CA, CH, CN, CO, CR, CU, CZ, DE, DK, DM, DO, DZ, EC, EE, EG, ES, FI, GB, GD, GE, GH, GM, GT, HN, HR, HU, ID, IL, IN, IS, JP, KE, KG, KM, KN, KP, KR, KZ, LA, LC, LK, LR, LS, LT, LU, LY, MA, MD, ME, MG, MK, MN, MW, MX, MY, MZ, NA, NG, NI, NO, NZ, OM, PG, PH, PL, PT, RO, RS, RU, SC, SD, SE, SG, SK, SL, SM, SV, SY, TJ, TM, TN, TR, TT, TZ, UA, UG, US, UZ, VC, VN, ZA, ZM, ZW.
- (84) Designated States (unless otherwise indicated, for every kind of regional protection available): ARIPO (BW, GH, GM, KE, LS, MW, MZ, NA, SD, SL, SZ, TZ, UG, ZM, ZW), Eurasian (AM, AZ, BY, KG, KZ, MD, RU, TJ, TM), European (AT, BE, BG, CH, CY, CZ, DE, DK, EE, ES, FI, FR, GB, GR, HU, IE, IS, IT, LT, LU, LV, MC, MT, NL, PL, PT, RO, SE, SI, SK, TR), OAPI (BF, BJ, CF, CG, CI, CM, GA, GN, GQ, GW, ML, MR, NE, SN, TD, TG).

- Published:**
- with international search report
  - before the expiration of the time limit for amending the claims and to be republished in the event of receipt of amendments

[Continued on next page]

(54) Title: LOAD SIDE VOLTAGE SENSING FOR AMI METROLOGY

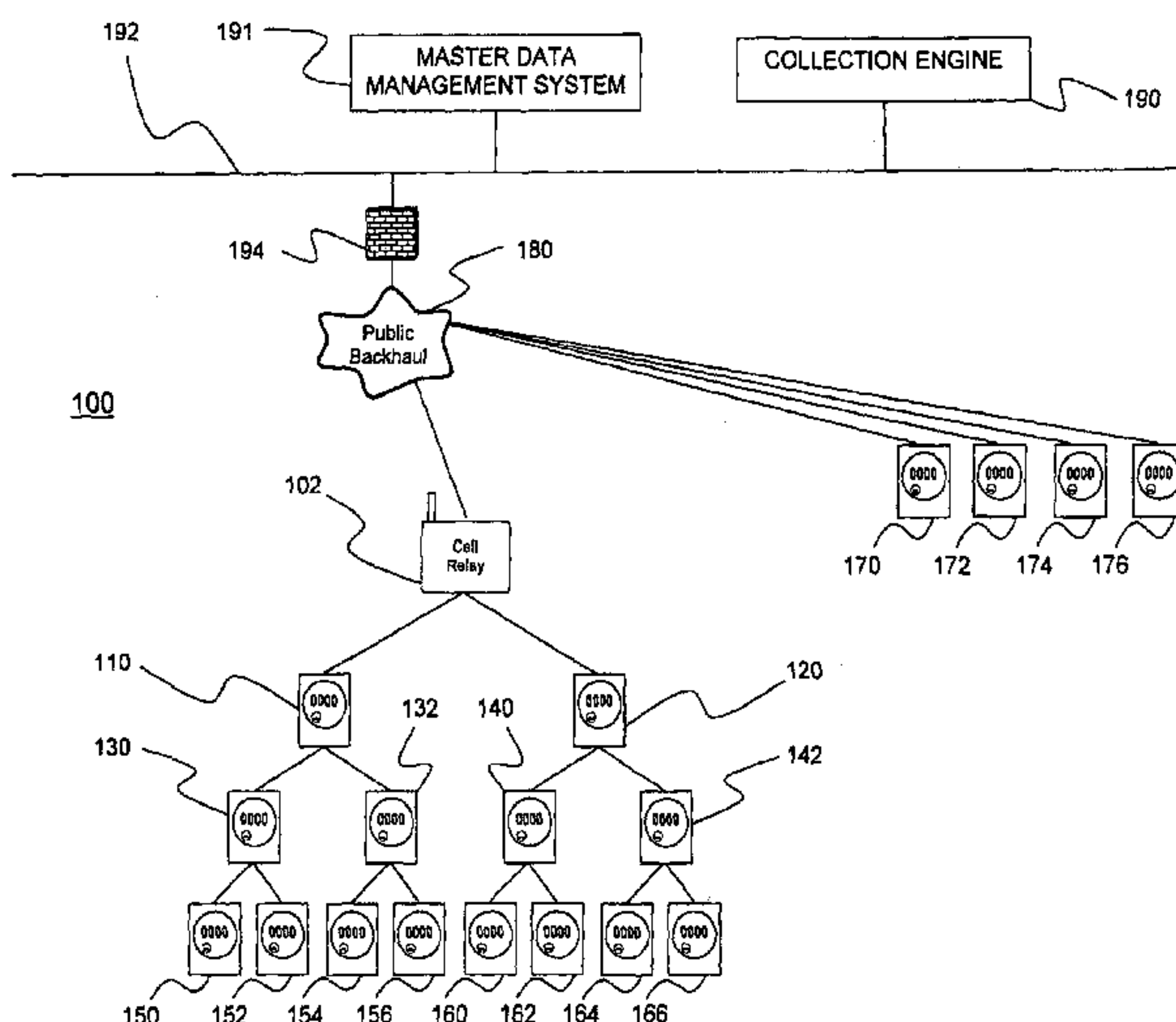

(57) Abstract: Disclosed are apparatus and methodology subject matters for providing improved functionality of a meter in a 2-way communications arrangement, such as an Advanced Metering System (AMS) or Infrastructure (AMI) More particularly, the present technology relates methodologies and apparatus for providing load side voltage sensing for utility meters which preferably are operable with remote disconnect features in an Advanced Metering Infrastructure (AMI) open operational framework The present subject matter provides enhanced capabilities resulting in improved functionality, increased safety, and greater economy vis-a-vis fraud detection for individual metrology components in an open operational framework Meters per the present subject matter utilize a detection circuit, which is situated generally downstream of a remote disconnect functionality Such detection circuit is able to sense whether voltage exists or doesn't exist at such relatively downstream, or load side location.

WO 2008/030416 A3

**WO 2008/030416 A3**



---

**(88) Date of publication of the international search report:**  
2 May 2008



**[0005]** The foregoing basic mechanical form of register was typically limited in its mode of output, so that only a very basic or lower level metrology function was achieved. Subsequently, electronic forms of metrology devices began to be introduced, to permit relatively higher levels of monitoring, involving different forms and modes of data.

**[0006]** In the context of electricity meters specifically, for a variety of management and billing purposes, it became desirable to obtain usage data beyond the basic kilowatt-hour consumption readings available with many electricity meters. For example, additional desired data included rate of electricity consumption, or date and time of consumption (so-called "time of use" data). Solid state devices provided on printed circuit boards, for example, utilizing programmable integrated circuit components, have provided effective tools for implementing many of such higher level monitoring functions desired in the electricity meter context.

**[0007]** In addition to the beneficial introduction of electronic forms of metrology, a variety of electronic registers have been introduced with certain advantages. Still further, other forms of data output have been introduced and are beneficial for certain applications, including wired transmissions, data output via radio frequency transmission, pulse output of data, and telephone line connection via such as modems or cellular linkups.

**[0008]** The advent of such variety and alternatives has often required utility companies to make choices about which technologies to utilize. Such choices have from time to time been made based on philosophical points and preferences and/or based on practical points such as, training and familiarity of field personnel with specific designs.

**[0009]** Another aspect of the progression of technology in such area of metrology is that various retrofit arrangements have been instituted. For example, some attempts have been made to provide basic metering devices with selected more advanced features without having to completely change or replace the basic meter in the field. For example, attempts have been made to outfit a basically mechanical metering device with electronic output of data, such as for facilitating radio telemetry linkages.

[0010] Another aspect of the electricity meter industry is that utility companies have large-scale requirements, sometimes involving literally hundreds of thousands of individual meter installations, or data points. Implementing incremental changes in technology, such as retrofitting new features into existing equipment, or attempting to implement changes to basic components which make various components not interchangeable with other configurations already in the field, can generate considerable industry problems.

5 [0011] Electricity meters typically include input circuitry for receiving voltage and current signals at the electrical service. Input circuitry of whatever type or specific design for receiving the electrical service current signals is referred to herein generally as current acquisition circuitry, while input circuitry of whatever type or design for receiving the electrical service voltage signals is referred to herein generally as voltage acquisition circuitry.

10 [0012] Electricity meter input circuitry may be provided with capabilities of monitoring one or more phases, depending on whether monitoring is to be provided in a single or multiphase environment. Moreover, it is desirable that selectively configurable circuitry may be provided so as to enable the provision of new, alternative or upgraded services or processing capabilities within an existing metering device. Such variations in desired monitoring environments or capabilities, however, lead to the requirement that a number of different metrology configurations be devised to accommodate the number of phases required or desired to be monitored or to provide alternative, additional or upgraded processing capability within a utility meter.

15 [0013] More recently a new ANSI protocol, ANSI C12.22, is being developed that may be used to permit open protocol communications among metrology devices from various manufacturers. C12.22 is the designation of the latest subclass of the ANSI C12.xx family of Meter Communication and Data standards presently under development. Presently defined standards include ANSI C12.18 relating to protocol specifications for Type 2 optical ports; ANSI C12.19 relating to Utility industry Meter Data Table definitions; and ANSI C12.21 relating to Plain Old Telephone Service (POTS) transport of C12.19 Data Tables definition. It should be appreciated that while the remainder of the present discussion may describe C12.22 as a standard protocol, that, at least at the time of filing the present

application, such protocol is still being developed so that the present disclosure is actually intended to describe an open protocol that may be used as a communications protocol for networked metrology and is referred to for discussion purposes as the C12.22 standard or C12.22 protocol.

5 [0014] C12.22 is an application layer protocol that provides for the transport of C12.19 data tables over any network medium. Current standards for the C12.22 protocol include: authentication and encryption features; addressing methodology providing unique identifiers for corporate, communication, and end device entities; self describing data models; and message routing over heterogeneous networks.

10 [0015] Much as HTTP protocol provides for a common application layer for web browsers, C12.22 provides for a common application layer for metering devices. Benefits of using such a standard include the provision of: a methodology for both session and session-less communications; common data encryption and security; a common addressing mechanism for use over both proprietary and non-  
15 proprietary network mediums; interoperability among metering devices within a common communication environment; system integration with third-party devices through common interfaces and gateway abstraction; both 2-way and 1-way communications with end devices; and enhanced security, reliability and speed for transferring meter data over heterogeneous networks.

20 [0016] To understand why utilities are keenly interested in open protocol communications; consider the process and ease of sending e-mails from a laptop computer or a smart phone. Internet providers depend on the use of open protocols to provide e-mail service. E-mails are sent and received as long as e-mail addresses are valid, mailboxes are not full, and communication paths are  
25 functional. Most e-mail users have the option of choosing among several Internet providers and several technologies, from dial-up to cellular to broadband, depending mostly on the cost, speed, and mobility. The e-mail addresses are in a common format, and the protocols call for the e-mail to be carried by communication carriers without changing the e-mail. The open protocol laid out in  
30 the ANSI C.12.22 standard provides the same opportunity for meter communications over networks.

[0017] One function previously known has been to integrally incorporate a whole service disconnection device with a meter. Such a feature or function, known also

as "remote disconnect," allows the entire electrical service to be switched off at a location where the remote disconnect switch (or meter with integral remote disconnect function) is installed.

[0018] In general, it may be possible to variously communicate instructions to such remote disconnect switch (whether such comprises an independent device or one integrally provided in conjunction with a meter). For example, there are so-called 2-way communications linkages which could offer such communication ability. The above-referenced Advanced Metering Infrastructure (AMI) environment would also generally provide such communication ability, though it is to be understood that 2-way communications are not the same as an AMI environment, per se.

[0019] In general, 2-way communications involve technology that supports bi-directional communications, and may involve an endpoint device such as a meter. Typical attributes in such circumstances are that there is generally high data collection reliability, the ability to obtain register reads generally on demand, and the ability to perform a demand reset, as well as the above-mentioned remote disconnect (and re-connect) functionality. AMI can generally provide such attributes as typically associated with a communications link as well as provide what may be thought of (in a metering context) as integral demand response, such as load control and verification, critical Peak Pricing management, consumer access, 3rd party devices certified on network, and other Advanced Metering functionality (now or later developed). So, generally speaking, AMI typically involves 2-way communications but not all 2-way communications involve or support AMI functionality.

[0020] In addition, the desire for increased processing capabilities as well as other considerations including, but not limited to, a desire to provide enhanced capabilities resulting in improved functionality, increased safety, and greater economy vis-à-vis fraud detection for individual metrology components in an open operational framework, leads to requirements for interfacing such components with system applications.

[0021] As such, it is desired to provide an improved interface for coupling utility meters to their respective load side environment, as well as their system applications in an open operational framework.

[0022] While various aspects and alternative embodiments may be known in the field of utility metering, no one design has emerged that generally encompasses the above-referenced characteristics and other desirable features associated with utility metering technology as herein presented.

5

### SUMMARY OF THE INVENTION

[0023] In view of the recognized features encountered in the prior art and addressed by the present subject matter, improved apparatus and methodologies of metrology devices in an open operational framework vis-à-vis their load side environment have been provided.

[0024] In exemplary arrangements, methodologies and apparatus have been provided to permit transmission of operational data and information between a utility meter and an operational application through a network.

15 [0025] In one of its simpler forms, the present technology provides methodologies and apparatus for interface between operational data and control via a network and meters operatively associated with such network.

[0026] One positive aspect of such interface is that it functions to provide enhanced capabilities resulting in improved functionality based on load side environment data at each respective meter operatively associated with such network.

20 [0027] Another positive aspect of such interface is that it functions to provide enhanced and/or increased safety capabilities resulting in improved functionality based on load side environment data at each respective meter operatively associated with such network.

[0028] Yet another positive aspect of such interface is that it functions to provide greater economy vis-à-vis enhanced and/or increased fraud detection capabilities resulting in improved functionality based on load side environment data at each respective meter operatively associated with such network.

30 [0029] In further present exemplary aspects, there is the provision preferably of a detection circuit, situated downstream of a remote disconnect switching functionality, and by which so-called "load side" voltage may be sense. In such fashion, the present technology advantageously permits verification that the

disconnect function was operative after an appropriate instruction, and alternately that a re-connect functionality was operative after an appropriate instruction.

[0030] In still additional exemplary aspects, the utilization of such detection functionality (in conjunction with other present subject matter), would permit the  
5 detection of possible fraud, based on the presence of a load-side voltage after a disconnect switching functionality had been operative. Because the economic losses of any fraud eventually are borne by all legitimate consumers, the present subject matter advantageously contributes to greater economy of operation to the extent that it can help deter and/or detect such fraud.

10 [0031] Yet further exemplary aspects of the present technology may relate to enhanced and/or increased safety capabilities. More specifically, verification of lack of a voltage before a switch is closed and service is re-connected could help prevent an equipment-damaging out-of-phase condition (regardless of whether the voltage is there improperly or legitimately, for example, legally shared from a  
15 neighbor's house). Again, any safety issue which is a threat to equipment can ultimately become a threat to the safety of persons, so the present subject matter advantageously contributes to greater safety of operation to the extent that it can help detect or prevent such potentially unsafe operating conditions.

[0032] One present exemplary embodiment relates to an electricity meter for  
20 use within an advanced metering system having and operating relative to a network, other meters, user interfaces, and central collection functionality. Such an exemplary meter preferably comprises a line side which receives electrical service when connected to such meter; a load side, downstream from the meter line side, which electrically connects with an electrical load when connected to  
25 such meter; a detection circuit, upstream from the meter load side and downstream from the meter line side, for detecting the presence of electricity at the meter load side; a remote disconnect switch, upstream from the detection circuit and downstream from the meter line side, controllably actuated for electrically connecting and disconnecting the meter line side relative to the meter load side, so  
30 that electrical service when present at the meter line side is, respectively, electrically connected with, and disconnected from, an electrical load when present at the meter load side; metrology, downstream from the meter line side and upstream from the meter load side, for monitoring the consumption or production

of electricity vis-à-vis electrical service and electrical load associated with such meter; and a bidirectional communications link, linking such meter and a network operating relative to an advanced metering system. With such an exemplary arrangement, data may be communicated regarding actuation of the remote  
5 disconnect switch and presence of electricity at the meter load side.

[0033] In various alternative embodiments of the foregoing present exemplary subject matter, such detection circuit may comprise a voltage sensor electrically in parallel with the meter load side; while the metrology may include current acquisition circuitry for receiving electrical service current signals, and voltage  
10 acquisition circuitry for receiving electrical service voltage signals.

[0034] In yet other present alternative arrangements, the bidirectional communications link may preferably include at least one communications module configured to effect bi-directional communications between the meter and other networked devices using an open standard meter communication protocol. In  
15 some of such alternatives, the at least one communications module may include one of an additional circuit board dedicated to WAN connectivity and one or more of GPRS, Ethernet, and RF LAN communications modules.

[0035] Other present exemplary embodiments are more related to an advanced metering system with added functionality based on meter load side sensing. One  
20 such exemplary present system may comprise a plurality of end devices, and a network including central collection functionality, and configured for bi-directional communications between the central collection functionality and each of such plurality of end devices.

[0036] In such foregoing exemplary system arrangement, at least some of such  
25 end devices may comprise electricity meters, each of such electricity meters having a line side for receiving electrical service; a load side, downstream from the meter line side, for electrically connecting with an electrical load; a detection circuit, upstream from the meter load side and downstream from the meter line side, for detecting the presence of electricity at the meter load side; a remote  
30 disconnect switch, upstream from the detection circuit and downstream from the meter line side, for controllably actuating for electrically connecting and disconnecting the meter line side relative to the meter load side, so that electrical service when present at the meter line side is, respectively, electrically connected

with, and disconnected from, an electrical load when present at the meter load side; and metrology, downstream from the meter line side and upstream from the meter load side, for monitoring the consumption or production of electricity vis-à-vis electrical service and electrical load associated with the meter. Further in such  
5 exemplary alternatives, with inclusion of such a network and related central collection functionality, data may be communicated across the network regarding actuation of the remote disconnect switch of an electricity meter and presence of electricity at the meter load side thereof.

[0037] In some other present exemplary alternatives of the foregoing  
10 arrangements, selected of the plurality of end devices may alternatively be configured to relay bi-directional communications between the central collection functionality and others of the plurality of end devices; while the network may further include at least one cell relay, with the bi-directional communication between the central collection functionality and selected of such plurality of end  
15 devices passing through the at least one cell relay. In such exemplary alternatives, bi-directional communication between the central collection functionality and selected of such plurality of end devices is conducted by way of the cell relay while bi-directional communication between the central collection functionality and others of the plurality of end devices is conducted directly.

[0038] In other of the foregoing alternatives, such network may be configured for  
20 bi-directional communications so as to include using an open standard meter communication protocol.

[0039] It is still to be understood by those of ordinary skill in the art that the present subject matter may equally relate to various methodologies, one present  
25 example of which relates to a methodology for improved functionality of an electricity meter used within an advanced metering system having and operating relative to a network, other meters, user interfaces, and central collection functionality. Such present exemplary preferably may comprise providing an electricity meter having a line side for receiving electrical service; a load side,  
30 downstream from the meter line side, for electrically connecting with an electrical load; a detection circuit, upstream from the meter load side and downstream from the meter line side, for detecting the presence of electricity at the meter load side; a remote disconnect switch, upstream from the detection circuit and downstream

from the meter line side, for controllably actuating for electrically connecting and disconnecting the meter line side relative to the meter load side, so that electrical service when present at the meter line side is, respectively, electrically connected with, and disconnected from, an electrical load when present at the meter load side; metrology, downstream from the meter line side and upstream from the meter load side, for monitoring the consumption or production of electricity vis-à-vis electrical service and electrical load associated with the meter; and a bidirectional communications link, linking the meter and a network operating relative to an advanced metering system. Such present exemplary may further include connecting electrical service to the meter line side; and connecting an electrical load to the meter load side, such that data may be communicated across the network regarding actuation of the remote disconnect switch and presence of electricity at the meter load side.

[0040] In present exemplary variations of such present methodology, a given method may further comprise actuating the remote disconnect switch so as to electrically disconnect the meter line side relative to the meter load side; and subsequently verifying that the remote disconnect switch electrically disconnected the meter line side relative to the meter load side. Other present variations may further comprise subsequent to verifying that the remote disconnect switch electrically disconnected the meter line side relative to the meter load side, actuating the remote disconnect switch so as to electrically re-connect the meter line side relative to the meter load side.

[0041] Still other present alternative methodologies may further comprise actuating the remote disconnect switch so as to electrically connect the meter line side relative to the meter load side; and subsequently verifying that the remote disconnect switch electrically connected the meter line side relative to the meter load side. As presently discussed hereinbelow, still further variations of the foregoing methodology may be practiced.

[0042] Still further, other present exemplary methodology embodiments may more relate to methodology for an advanced metering system with added functionality based on meter load side sensing. One exemplary such methodology may comprise providing a plurality of end devices, at least some of which end devices comprise electricity meters, each of such electricity meters having a line

side for receiving electrical service; a load side, downstream from the meter line side, for electrically connecting with an electrical load; a detection circuit, upstream from the meter load side and downstream from the meter line side, for detecting the presence of electricity at the meter load side; a remote disconnect switch, upstream from the detection circuit and downstream from the meter line side, for controllably actuating for electrically connecting and disconnecting the meter line side relative to the meter load side, so that electrical service when present at the meter line side is, respectively, electrically connected with, and disconnected from, an electrical load when present at the meter load side; and metrology, downstream from the meter line side and upstream from the meter load side, for monitoring the consumption or production of electricity vis-à-vis electrical service and electrical load associated with the meter; providing a network including central collection functionality; configuring the network for bi-directional communications between the central collection functionality and each of the plurality of end devices; connecting electrical service to the meter line side of at least one of such electricity meters; and connecting an electrical load to the meter load side of such at least one electricity meter, such that data may be communicated across the network regarding actuation of the remote disconnect switch thereof and presence of electricity at the meter load side thereof.

[0043] In various present alternatives of the foregoing methodology for an advanced metering system, each detection circuit of an electricity meter comprises a voltage sensor electrically in parallel with the meter load side, such detection circuit including a filtering capacitor, an over-current protection resistor, an opto-isolator, and a transient voltage suppressor for setting the turn-on voltage of the voltage sensor; the metrology of each electricity meter includes current acquisition circuitry for receiving electrical service current signals, and voltage acquisition circuitry for receiving electrical service voltage signals, with such current acquisition circuitry and voltage acquisition circuitry configured for receiving multi-phase electrical service current and voltage signals, respectively, and such metrology is configured for correction of any monitoring offset relative to electrical service caused by the presence of the detection circuit in such electricity meter; and each electricity meter includes at least one communications module configured to effect bi-directional communications between the meter and other

96164-6T

networked devices using an open standard meter communication protocol, with such at least one communications module including an additional circuit board dedicated to WAN connectivity, or one or more of GPRS, Ethernet, and RF LAN communications modules.

- 5 **[0043a]** In an aspect, there is provided an electricity meter for use within an advanced metering system having and operating relative to a network, other meters, user interfaces, and central collection functionality, comprising: a line side which receives electrical service when connected to said meter; a load side, downstream from said meter line side, which electrically connects with an electrical load when
- 10 connected to said meter; a detection circuit, upstream from said meter load side and downstream from said meter line side, for detecting the presence of electricity at said meter load side; a remote disconnect switch, upstream from said detection circuit and downstream from said meter line side, controllably actuated for electrically connecting and disconnecting said meter line side relative to said meter load side, so that
- 15 electrical service when present at said meter line side is, respectively, electrically connected with, and disconnected from, an electrical load when present at said meter load side; metrology, downstream from said meter line side and upstream from said meter load side, for monitoring the consumption or production of electricity vis-à-vis electrical service and electrical load associated with said meter; and a bidirectional
- 20 communications link, linking said meter and a network operating relative to an advanced metering system, such that data may be communicated regarding actuation of said remote disconnect switch and presence of electricity at said meter load side; wherein said detection circuit comprises a voltage sensor electrically in parallel with said meter load side, said detection circuit comprising a capacitor, an
- 25 over-current protection resistor, an opto-isolator, and a transient voltage suppressor for setting the turn-on voltage of said voltage sensor, with said capacitor, said resistor, and said opto-isolator in series and, as a group, in parallel with said meter load side, and with said capacitor placed on the input side of said opto-isolator to provide a voltage drop.

96164-6T

**[0043b]** In another aspect, there is provided a methodology for improved functionality of an electricity meter used within an advanced metering system having and operating relative to a network, other meters, user interfaces, and central collection functionality, comprising: providing an electricity meter having: a line side  
5 for receiving electrical service; a load side, downstream from the meter line side, for electrically connecting with an electrical load; a detection circuit, upstream from the meter load side and downstream from the meter line side, for detecting the presence of electricity at the meter load side; a remote disconnect switch, upstream from the detection circuit and downstream from the meter line side, for controllably actuating  
10 for electrically connecting and disconnecting the meter line side relative to the meter load side, so that electrical service when present at the meter line side is, respectively, electrically connected with, and disconnected from, an electrical load when present at the meter load side; metrology, downstream from the meter line side and upstream from the meter load side, for monitoring the consumption or production  
15 of electricity vis-à-vis electrical service and electrical load associated with the meter; and a bidirectional communications link, linking the meter and a network operating relative to an advanced metering system; connecting electrical service to the meter line side; and connecting an electrical load to the meter load side, such that data may be communicated across the network regarding actuation of the remote disconnect  
20 switch and presence of electricity at the meter load side; wherein said detection circuit comprises a voltage sensor electrically in parallel with said meter load side, said detection circuit comprising a capacitor, an over-current protection resistor, an opto-isolator, and a transient voltage suppressor for setting the turn-on voltage of said voltage sensor, with said capacitor, said resistor, and said opto-isolator in series  
25 and, as a group, in parallel with said meter load side, and with said capacitor placed on the input side of said opto-isolator to provide a voltage drop.

**[0043c]** In a further aspect, there is provided methodology for an advanced metering system with added functionality based on meter load side sensing, comprising: providing a plurality of end devices, at least some of which end devices  
30 comprise electricity meters, each of such electricity meters having a line side for

96164-6T

receiving electrical service; a load side, downstream from the meter line side, for electrically connecting with an electrical load; a detection circuit, upstream from the meter load side and downstream from the meter line side, for detecting the presence of electricity at the meter load side; a remote disconnect switch, upstream from the  
5 detection circuit and downstream from the meter line side, for controllably actuating for electrically connecting and disconnecting the meter line side relative to the meter load side, so that electrical service when present at the meter line side is, respectively, electrically connected with, and disconnected from, an electrical load when present at the meter load side; and metrology, downstream from the meter line  
10 side and upstream from the meter load side, for monitoring the consumption or production of electricity vis-à-vis electrical service and electrical load associated with the meter; providing a network including central collection functionality; configuring the network for bi-directional communications between the central collection functionality and each of the plurality of end devices; connecting electrical service to  
15 the meter line side of at least one of such electricity meters; and connecting an electrical load to the meter load side of such at least one electricity meter, such that data may be communicated across the network regarding actuation of the remote disconnect switch thereof and presence of electricity at the meter load side thereof; wherein said detection circuit comprises a voltage sensor electrically in parallel with  
20 said meter load side, said detection circuit comprising a capacitor, an over-current protection resistor, an opto-isolator, and a transient voltage suppressor for setting the turn-on voltage of said voltage sensor, with said capacitor, said resistor, and said opto-isolator in series and, as a group, in parallel with said meter load side, and with said capacitor placed on the input side of said opto-isolator to provide a voltage drop.

25 **[0043d]** In a yet further aspect, there is provided an advanced metering system with added functionality based on meter load side sensing, comprising: a plurality of end devices, at least some of which end devices comprise electricity meters, each of such electricity meters having a line side for receiving electrical service; a load side,  
30 downstream from the meter line side, for electrically connecting with an electrical load; a detection circuit, upstream from the meter load side and downstream from the

96164-6T

meter line side, for detecting the presence of electricity at the meter load side; a remote disconnect switch, upstream from the detection circuit and downstream from the meter line side, for controllably actuating for electrically connecting and disconnecting the meter line side relative to the meter load side, so that electrical service when present at the meter line side is, respectively, electrically connected with, and disconnected from, an electrical load when present at the meter load side; and metrology, downstream from the meter line side and upstream from the meter load side, for monitoring the consumption or production of electricity vis-à-vis electrical service and electrical load associated with the meter; a network including central collection functionality, and configured for bi-directional communications between the central collection functionality and each of said plurality of end devices, such that data may be communicated across said network regarding actuation of the remote disconnect switch of an electricity meter and presence of electricity at the meter load side thereof; wherein said detection circuit comprises a voltage sensor electrically in parallel with said meter load side, said detection circuit comprising a capacitor, an over-current protection resistor, an opto-isolator, and a transient voltage suppressor for setting the turn-on voltage of said voltage sensor, with said capacitor, said resistor, and said opto-isolator in series and, as a group, in parallel with said meter load side, and with said capacitor placed on the input side of said opto-isolator to provide a voltage drop.

**[0044]** Additional objects and advantages of the present subject matter are set forth in, or will be apparent to, those of ordinary skill in the art from the detailed description herein. Also, it should be further appreciated that modifications and variations to the specifically illustrated, referred and discussed features, elements, and steps hereof may be practiced in various embodiments and uses of the present subject matter without departing from the spirit and scope of the subject matter. Variations may include, but are not limited to, substitution of equivalent means, features, or steps for those illustrated, referenced, or discussed, and the functional, operational, or positional reversal of various parts, features, steps, or the like.

96164-6T

**[0045]** Still further, it is to be understood that different embodiments, as well as different presently preferred embodiments, of the present subject matter may include various combinations or configurations of presently disclosed features, steps, or elements, or their equivalents including combinations of features, parts, or steps or configurations thereof not expressly shown in the figures or stated in the detailed description of such figures. Additional embodiments of the present subject matter, not necessarily expressed in the summarized section, may include and incorporate various combinations of aspects of features, components, or steps referenced in the summarized objects above, and/or other features, components, or steps as otherwise discussed in this application. Those of ordinary skill in the art will better appreciate the features and aspects of such embodiments, and others, upon review of the remainder of the specification.

#### **BRIEF DESCRIPTION OF THE DRAWINGS**

15

**[0046]** A full and enabling disclosure of the present subject matter, including the best mode thereof, directed to one of ordinary skill in the art, is set forth in the specification, which makes reference to the appended figures, in which:

[0047] Figure 1 is a block diagram overview illustration of an exemplary Advanced Metering System (AMS) or Infrastructure (AMI) deployment incorporating various of both apparatus and methodology aspects of the present subject matter;

5 [0048] Figure 2 illustrates for further background discussion purposes a block diagram of an exemplary wathour meter incorporating features in accordance with present ANSI wathour meter configuration standards;

[0049] Figure 3 illustrates for further background discussion purposes a block diagram of an exemplary wathour meter incorporating features in accordance with  
10 an alternative arrangement of an exemplary wathour meter configuration; and

[0050] Figure 4 illustrates for further disclosure purposes relating to present subject matter a block diagram of an exemplary wathour meter incorporating features in accordance with present ANSI wathour meter configuration standards, incorporating remote disconnect features, and further incorporating subject matter  
15 of the presently disclosed technology relative to load side voltage sensing and related present features.

[0051] Repeat use of reference characters throughout the present specification and appended drawings is intended to represent same or analogous features, elements, or steps of the present subject matter.

20

### **DETAILED DESCRIPTION OF THE PREFERRED EMBODIMENTS**

[0052] As discussed in the Summary of the Invention section, the present subject matter is particularly concerned with the provision of improved  
25 corresponding apparatus and methodologies allowing enhanced functionality of metrology devices in an open operational framework. More particularly, the present technology relates to methodologies and apparatus for providing load side voltage sensing for utility meters which preferably are operable with remote disconnect features in an Advanced Metering Infrastructure (AMI) open operational  
30 framework.

[0053] Selected combinations of aspects of the disclosed technology correspond to a plurality of different embodiments of the present subject matter. It should be noted that each of the exemplary embodiments presented and discussed herein

should not insinuate limitations of the present subject matter. Features or steps illustrated or described as part of one embodiment may be used in combination with aspects of another embodiment to yield yet further embodiments.

5 Additionally, certain features may be interchanged with similar devices or features not expressly mentioned which perform the same or similar function.

[0054] Reference will now be made in detail to presently preferred embodiments of the subject methodologies and apparatus. Referring to the drawings, Figure 1 is a block diagram overview illustration of an exemplary Advanced Metering System (AMS) or Infrastructure (AMI) deployment 100 generally in accordance with the present subject matter incorporating various of both apparatus and methodology aspects of the present subject matter.

[0055] Advanced Metering System (AMS) 100 in pertinent part is preferably designed and built around industry standard protocols and transports, and therefore is intended to work with standards compliant components from third parties. In other words, AMS 100 is configured to be transparent in a transportation context, such that the exemplary respective meters may be interrogated (such as using representative Collection Engine generally 190) regardless of what network infrastructure exists inbetween or among such components. Moreover, due to such transparency, the respective meters preferably may also respond to Collection Engine 190 in the same manner. Preferably, as intended to be represented by the illustration in Figure 1, Collection Engine 190 is capable of integrating Radio, PLC (Power Line Communications), and IP (Internet Protocol) connected meters, details of which communications form no particular aspects of the present subject matter.

[0056] In general, it is preferred that the system represented in present Figure 1 provides full two-way messaging to every device. For example, the respectively represented meter devices may be variously configured to provide differing communications capabilities. In exemplary configurations, one or more of GPRS, Ethernet, and RF LAN communications modules may be provided. GPRS will allow meters to be IP addressable over a public backhaul and provide more bandwidth than the meter will likely ever require, but may incur ongoing subscription costs. Ethernet connectivity can be used to bridge to third party technologies, including WiFi, WiMax, in-home gateways, and BPL (Broadband

over Power Lines), without integrating any of these technologies directly into the metering device, but with the tradeoff of requiring external wiring and a two part solution. Ethernet devices may be used primarily in pilots and other special applications, and they additionally may be ideal for certain high-density RF-  
5 intolerant environments, such as meter closets. Due to the increased complexity of managing certain interfaces, for example, such as a WAN interface, with its more sophisticated link negotiation requirements and TCP/IP (Transmission Control Protocol/Internet Protocol) stack, WAN connected meters may include an additional circuit board dedicated to WAN connectivity. All such alternative and  
10 exemplary supporting boards, if required, are considered to be part of preferred embodiments that sense and communicate control and information data in accordance with the present subject matter, whether using ANSI standard C12.22 communications protocol or otherwise.

[0057] Also, as discussed in greater detail herein, it is to be understood that the  
15 representative exemplary meter devices of present Figure 1 are intended to represent meter devices associated respectively with remote disconnect (and re-connect) functionality, as well as other present features relative to load side voltage sensing and related features.

[0058] Communication with the Collection Engine 190 is preferably performed  
20 over an Internet Protocol connection, represented by such connection 192. The Wide-Area-Network is a fully routable, addressable, IP network that may involve a variety of different technologies including, but not limited to, GPRS, WiFi, WiMax, Fiber, Private Ethernet, BPL, or any other connection with sufficiently high bandwidth and ability to support full two-way IP communication. Several  
25 assumptions (that is, criteria of the present subject matter) may be made regarding the IP WAN. Collection Engine 190 is preferably implemented so as to be able to communicate directly with other respective nodes on the IP WAN. While communications may be conducted through a firewall 194, it is not necessary that such be proxied, unless the proxy is itself a C12.22 node functioning as a relay  
30 between a private IP network and the public IP WAN.

[0059] The Advanced Metering System as used in conjunction with the present technology provides a series (or plurality) of services (functionalities) to utilities. Beyond its most basic implementation (daily feeds of residential interval or TOU

(Time of Use) data), it may provide power outage and restoration notifications, on-demand readings, firmware updates, load control/demand response, gas meter readings, and in-home display messages. All of such functions (services) may be preferably communicated via the ANSI standard C12.22 protocol.

5 [0060] With further reference to present reference to Figure 1, it will be seen that an exemplary Advanced Metering System (AMS) generally 100 deployment has been illustrated for exemplary purposes only with a single RF LAN cell, with twelve respective exemplary member nodes organized into three levels, as well as four directly connected IP meters 170, 172, 174, and 176. In such exemplary  
10 arrangement of a system in conjunction with which the present subject matter may be practiced, all respective meter devices 110, 120, 130, 132, 140, 142, 150, 152, 154, 156, 160, 162, 164, 166, 170, 172, 174, and 176, Cell Relay 102, and Collection Engine 190, preferably have C12.22 network addresses, with Collection Engine 190 preferably having multiple C12.22 addresses to allow for separate  
15 addressing between different services (functionalities). Representative Meter (or Master) Data Management System 191 is not part of any such C12.22 network, but preferably it will be implemented so as to communicate over the Utility LAN 192 to Collection Engine 190 via Web Services. Communications between Cell Relay 102 and Utility LAN 192 variously involve Public Backhaul 180 and firewall  
20 194, in a manner as referenced above, as well understood by those of ordinary skill in the art.

[0061] The meter data acquisition process may be processed through operation of the Meter (or Master) Data Management System 191, initiating a request for such data. Such requests may be sent out either directly to the device (in the case  
25 of an IP connected meter, such as 170), or to Cell Relay 102 that relays the message out to all appropriate nodes. While various tables per a manufacturer's stored procedure may be used, in response to C12.22 stored procedure calls, the various AMS enabled meters of Figure 1 are preferably field programmable, via C12.22 tables, as to the type data to be included in any default upload. In any  
30 event, response processing can use the configured data about an end device and the response message from an end device to determine the results from such device. In the instance of the present subject matter, such operations allow responses that contain logs from the devices, such as relating to above-referenced

load side sensed voltage data at a particular installation, all in accordance with the present subject matter.

[0062] Figure 2 illustrates for further background discussion purposes a block diagram of a representative exemplary watt-hour meter generally 200 incorporating features in accordance with present ANSI watt-hour meter configuration standards. Figure 3 on the other hand illustrates for further background discussion purposes a block diagram of a representative exemplary watt-hour meter generally 300 incorporating features in accordance with an alternative arrangement of an exemplary watt-hour meter configuration.

10 [0063] The following includes a brief discussion relative to power consumption of a load side voltage detect circuit of an RDS (Remote Disconnect Switch) enabled meter per present subject matter, and the effects thereof on accuracy. As referenced in the above "Background" section as a general proposition, with all watt meters, there is essentially a voltage circuit and a current circuit. If each is separately calibrated, in general the watts determined with such arrangement will never be accurate if  $watts = V \cdot A \cos(\theta)$ . The reasoning behind such statement is because in the case of a watt-hour meter design that has the voltmeter portion thereof above (in a supply versus load context) the current meter portion thereof, some current is lost in the voltage circuit and thus such current is not measured by the ammeter. Conversely, in the case of a watt-hour meter design where the ammeter portion is above the voltmeter portion (again, in the supply versus load context), there will be some voltage drop in the ammeter which is not measured by the voltmeter. Therefore, from a design perspective, some "burden" from the voltmeter or the ammeter must be intentionally removed from the resulting watt reading.

[0064] As well known to those of ordinary skill in the art, all ANSI standard watt-hour meters are arranged in the manner of the watt-hour meter design generally 200 as diagrammatically represented in present Figure 2. Such is the watt-hour meter design that has the voltmeter portion generally 210 thereof above the current meter portion generally 220 thereof (in a supply generally 230 versus load generally 240 context). Because the burden of the ammeter portion generally 220 is never removed, some current is lost in the voltage circuit generally 210 and thus such current is not measured by the ammeter generally 220. From an

industry standard perspective, it is generally recognized and understood that (if unaccounted for) any current coil losses would be paid for by the end user. Such fact is equally true in the instance of practicing the present subject matter with reference to any additional resistance losses in the contacts and metal conductors, such as copper, associated with a remote disconnect switch functionality.

5 [0065] Conversely, in the watt-hour meter design generally 300 diagrammatically represented in present Figure 3, the burden in the voltmeter portion generally 210 is not measured, and hence any resulting watt losses would be incurred by the utility supplying service to such meter 300.

10 [0066] Figure 4 illustrates for further disclosure purposes relating to present subject matter a block diagram of an exemplary watt-hour meter generally 400 incorporating features in accordance with present ANSI watt-hour meter configuration standards, incorporating remote disconnect features generally 450, and further incorporating subject matter of the presently disclosed technology relative to load side voltage sensing and related present features. It is also to be understood by those of ordinary skill in the art that the description herewith of an exemplary meter 400 in accordance with present subject matter is likewise a description of the representative meters variously illustrated in present Figure 1. It is also to be understood that in some implementations of the present subject matter, not all of the meters utilized in a particular arrangement must conform with all or a particular subset of the features presently described, as some meters in an arrangement may practice the present subject matter while some do not.

15 [0067] The following more particularly describes present subject matter, using for example, load side voltage data in conjunction with a meter having remotely disconnectable service features. In the context of present Figure 4, it is to be understood that the terminology "downstream" means towards the load side generally 440 thereof versus the source or line side generally 430 thereof, which would be "upstream" of the load side 440. Because integration of a whole service disconnection device or feature is not unique to the present subject matter, and details thereof form no particular present aspects of the subject technology, an RDS (Remote Disconnect Switch) device is only generally represented by block diagram 450. As such, the present subject matter is intended to be usable in

combination with all such types of devices and functionality and equivalents thereof, whether now or later existing.

[0068] In more particular, the present subject matter utilizes a detection circuit or means generally 460, which is situated generally downstream of the RDS 450.

5 Such detection circuit or means 460 has a primary purpose and/or function of being able to sense whether voltage exists or doesn't exist at such relatively downstream, or load side location. Providing such functionality allows for the following, all in accordance with the present subject matter: (a) verification that the RDS 450 switch did open subsequent to an instruction or command to do so, (b)  
10 identification of possible user fraud, as would possibly be reflected by the presence of voltage at a time when RDS 450 is open, (c) verification that RDS 450 did re-close after having been given an instruction or command to close, and (d) verification of lack of voltage present before re-closing RDS 450, which serves an important safety feature. Such latter verification is important as a safety feature  
15 because if power is being supplied, legally or illegally to the load side generally 440 of RDS 450, then RDS 450 could close in an out-of-phase condition, which is often hazardous to any equipment involved. Hazards to equipment have a way of subsequently also becoming hazards to persons, whether for example, through resulting shock or fire conditions.

20 [0069] Other presently advantageous aspects of the present subject matter which will be understood by those of ordinary skill in the art is that the present exemplary arrangements provide a mechanism for using, for example, firmware-based correction of the metering offset caused by any burden of the detection circuit generally 460. Normally such burden would be billed to the customer, but  
25 the present technology advantageously permits such cost to be redirected so as to be born by the utility. Although such is a relatively very low energy usage, it is nonetheless measurable, and a meter fabricated in accordance with the present subject matter will provide a built in correction for such usage burden.

[0070] One possible implementation of the present subject matter is to compare  
30 the phase angle of the line side voltage generally 430 to the load side voltage 440 (which, of course, under normal disconnect conditions, should not exist). If such compared angle is changing, then the load side generally 440 is likely powered by a stand-alone generator, which would normally mean that there are no fraudulent

practices involved. However, if the voltage angles remain synchronized (that is, they are not changing), then power is coming from a common source, which should mean the utility supplying the line or source side generally 430. However, there are at least two possible ways for such utility source to be involved. One  
5 would be from a customer's neighbor (which could be legally obtained or possibly illegally obtained). Another possibility would be from some sort of by-pass arrangement (which would be improper, illegal, or fraudulent). Therefore, synchronized voltage angles would typically merit further investigation by the utility to determine whether there were some improper activities involved.

10 [0071] An idealized (that is, simplified) version of a present exemplary voltage detection circuit 460 is shown in Figure 4. Note that due to its position in the meter 400 as represented, it is seen as a parallel load, and is metered the same as any other load would be. The representative capacitor generally 470 is used to drop  
15 60Hz voltage. The representative resistor 480 generally is used to prevent over-current during surges. The representative LED generally 490 is part of an opto-isolator that prevents line generally 430 and load generally 440 from being tied together whenever RDS 450 is opened. There is also a TVS (Transient Voltage Suppressor) generally 492 that sets the turn-on threshold of the system or circuitry generally 460. A TVS is often basically a form of back to back zener diode, and it  
20 is where most of the watts loss occurs.

[0072] If the meter generally 400 is calibrated so-called closed link (well known to one of ordinary skill in the art), then the afore-mentioned load would be metered by the utility, but not by any standard instrument or equipment (if phantom loaded). Such fact is because the current flowing in the detection circuit generally 460 is  
25 supplied by the voltage source, the same as the potential sense circuit, and the power supply (the last 2 elements are not metered by the meter, however, as they are before the current circuits, as stated above). In such case, the described loss will be calibrated out of the meter at the test point, but will show as an offset, which will not be calibrated out.

30 [0073] On the other hand, if the meter is calibrated so-called open link (well known to one of ordinary skill in the art), then there will be no voltage across the detection circuit generally 460. Therefore, this is no corresponding current or load. It will not, therefore be sensed by either the meter generally 400 or any

standard instrument or equipment. Such will be an offset in the load curve that is not normalized at such test point.

[0074] From the foregoing, one of ordinary skill in the art will note an implication of a differential error between open and closed link testing. Open link ignores the  
5   aforementioned loss, while closed link does not. Thought of another way, closed link will always show the meter "slower" (to use the language of the old mechanical meter pictured as having a rotating dial, the speed of which reflects the rate of consumption of the measured commodity, such as electricity).

[0075] In view of all the foregoing, including present industry practices with  
10   respect to burden shifting, one preferred manner of practicing the present subject matter would be to calibrate per the so-called closed link approach. In such circumstances, the following error data and corresponding calculations would be applicable:

Amount of error: This is 0.3W.

15   240V, 30A, we are looking at 7200W for an error of 0.004% fast

240V, 2A (ANSI lower limit), 480W or .06% fast

240V, 2mA, we are looking at 4.8 watts or an error of 6.25% fast

It should be appreciated that such results appropriately correlate with reasoned expectations, as there is more power delivered to the meter than a customer is  
20   actually consuming. All of the delivered power is metered; therefore, the meter resultingly shows "fast" (using the "rotation" connotations above with reference to metering terminology). Therefore, meters tested on closed link devices (for example, such as a so-called RFL produced now by Radian Research) will show results at the low end which are regarded as being fast, but will show results which  
25   are correct (if all other factors are equal) if tested on open link equipment.

[0076] While the present subject matter has been described in detail with respect to specific embodiments thereof, it will be appreciated that those skilled in the art, upon attaining an understanding of the foregoing may readily produce alterations to, variations of, and equivalents to such embodiments. Accordingly,  
30   the scope of the present disclosure is by way of example rather than by way of limitation, and the subject disclosure does not preclude inclusion of such modifications, variations and/or additions to the present subject matter as would be readily apparent to one of ordinary skill in the art.

96164-6T

CLAIMS:

1. An electricity meter for use within an advanced metering system having and operating relative to a network, other meters, user interfaces, and central collection  
5 functionality, comprising:
- a line side which receives electrical service when connected to said meter;
  - a load side, downstream from said meter line side, which electrically connects with an electrical load when connected to said meter;
  - 10 a detection circuit, upstream from said meter load side and downstream from said meter line side, for detecting the presence of electricity at said meter load side;
  - a remote disconnect switch, upstream from said detection circuit and downstream from said meter line side, controllably actuated for electrically connecting and disconnecting said meter line side relative to said meter load side, so that electrical service when present at said meter line side is, respectively, electrically  
15 connected with, and disconnected from, an electrical load when present at said meter load side;
  - metrology, downstream from said meter line side and upstream from said meter load side, for monitoring the consumption or production of electricity vis-à-vis electrical service and electrical load associated with said meter; and
  - 20 a bidirectional communications link, linking said meter and a network operating relative to an advanced metering system, such that data may be communicated regarding actuation of said remote disconnect switch and presence of electricity at said meter load side;
  - wherein said detection circuit comprises a voltage sensor electrically in parallel  
25 with said meter load side, said detection circuit comprising a capacitor, an over-current protection resistor, an opto-isolator, and a transient voltage suppressor for setting the turn-on voltage of said voltage sensor, with said capacitor, said resistor, and said opto-isolator in series and, as a group, in parallel with said meter load side, and with said capacitor placed on the input side of said opto-isolator to provide a  
30 voltage drop.

96164-6T

2. An electricity meter as in claim 1, wherein:

said metrology includes current acquisition circuitry for receiving electrical service current signals, and voltage acquisition circuitry for receiving electrical service voltage signals.

5

3. An electricity meter as in claim 2, wherein:

said current acquisition circuitry and said voltage acquisition circuitry are configured for receiving multi-phase electrical service current and voltage signals, respectively.

10

4. An electricity meter as in claim 1, wherein said bidirectional communications link includes at least one communications module configured to effect bi-directional communications between said meter and other networked devices using an open standard meter communication protocol.

15

5. An electricity meter as in claim 4, wherein said at least one communications module includes one of an additional circuit board dedicated to WAN connectivity and one or more of GPRS, Ethernet, and RF LAN communications modules.

20 6. An electricity meter as in claim 1, wherein said metrology is configured for correction of any monitoring offset relative to electrical service caused by the presence of said detection circuit.

7. A methodology for improved functionality of an electricity meter used within an advanced metering system having and operating relative to a network, other meters, user interfaces, and central collection functionality, comprising:

providing an electricity meter having:

a line side for receiving electrical service;

a load side, downstream from the meter line side, for electrically

30 connecting with an electrical load;

96164-6T

a detection circuit, upstream from the meter load side and downstream from the meter line side, for detecting the presence of electricity at the meter load side;

5 a remote disconnect switch, upstream from the detection circuit and downstream from the meter line side, for controllably actuating for electrically connecting and disconnecting the meter line side relative to the meter load side, so that electrical service when present at the meter line side is, respectively, electrically connected with, and disconnected from, an electrical load when present at the meter load side;

10 metrology, downstream from the meter line side and upstream from the meter load side, for monitoring the consumption or production of electricity vis-à-vis electrical service and electrical load associated with the meter; and

a bidirectional communications link, linking the meter and a network operating relative to an advanced metering system;

15 connecting electrical service to the meter line side; and

connecting an electrical load to the meter load side, such that data may be communicated across the network regarding actuation of the remote disconnect switch and presence of electricity at the meter load side;

20 wherein said detection circuit comprises a voltage sensor electrically in parallel with said meter load side, said detection circuit comprising a capacitor, an over-current protection resistor, an opto-isolator, and a transient voltage suppressor for setting the turn-on voltage of said voltage sensor, with said capacitor, said resistor, and said opto-isolator in series and, as a group, in parallel with said meter load side, and with said capacitor placed on the input side of said opto-isolator to provide a  
25 voltage drop.

8. A methodology as in claim 7, further comprising:

actuating the remote disconnect switch so as to electrically disconnect the meter line side relative to the meter load side; and

30 subsequently verifying that the remote disconnect switch electrically disconnected the meter line side relative to the meter load side.

96164-6T

9. A methodology as in claim 8, further comprising:  
subsequent to verifying that the remote disconnect switch electrically disconnected  
the meter line side relative to the meter load side, actuating the remote disconnect  
5 switch so as to electrically re-connect the meter line side relative to the meter load  
side.
10. A methodology as in claim 7, further comprising:  
actuating the remote disconnect switch so as to electrically connect the meter  
10 line side relative to the meter load side; and  
subsequently verifying that the remote disconnect switch electrically connected  
the meter line side relative to the meter load side.
11. A methodology as in claim 7, further comprising:  
15 actuating the remote disconnect switch so as to electrically disconnect the meter line  
side relative to the meter load side; and  
subsequently identifying possible user fraud by verifying the presence of  
electricity at the meter load side.
- 20 12. A methodology as in claim 7, wherein the metrology includes current  
acquisition circuitry for receiving electrical service current signals, and voltage  
acquisition circuitry for receiving electrical service voltage signals, with such current  
acquisition circuitry and voltage acquisition circuitry configured for receiving multi-  
phase electrical service current and voltage signals, respectively.
- 25 13. A methodology as in claim 7, wherein the bidirectional communications link  
includes at least one communications module configured to effect bi-directional  
communications between the meter and other networked devices using an open  
standard meter communication protocol, with such at least one communications  
30 module including an additional circuit board dedicated to WAN connectivity, or one or  
more of GPRS, Ethernet, and RF LAN communications modules.

96164-6T

14. A methodology as in claim 7, wherein the metrology is configured for correction of any monitoring offset relative to electrical service caused by the presence of the detection circuit.

5

15. Methodology for an advanced metering system with added functionality based on meter load side sensing, comprising:

providing a plurality of end devices, at least some of which end devices comprise electricity meters, each of such electricity meters having a line side for receiving electrical service; a load side, downstream from the meter line side, for electrically connecting with an electrical load; a detection circuit, upstream from the meter load side and downstream from the meter line side, for detecting the presence of electricity at the meter load side; a remote disconnect switch, upstream from the detection circuit and downstream from the meter line side, for controllably actuating for electrically connecting and disconnecting the meter line side relative to the meter load side, so that electrical service when present at the meter line side is, respectively, electrically connected with, and disconnected from, an electrical load when present at the meter load side; and metrology, downstream from the meter line side and upstream from the meter load side, for monitoring the consumption or production of electricity vis-à-vis electrical service and electrical load associated with the meter;

providing a network including central collection functionality;  
configuring the network for bi-directional communications between the central collection functionality and each of the plurality of end devices;

25 connecting electrical service to the meter line side of at least one of such electricity meters; and

connecting an electrical load to the meter load side of such at least one electricity meter, such that data may be communicated across the network regarding actuation of the remote disconnect switch thereof and presence of electricity at the meter load side thereof;

30

96164-6T

wherein said detection circuit comprises a voltage sensor electrically in parallel with said meter load side, said detection circuit comprising a capacitor, an over-current protection resistor, an opto-isolator, and a transient voltage suppressor for setting the turn-on voltage of said voltage sensor, with said capacitor, said resistor, and said opto-isolator in series and, as a group, in parallel with said meter load side, and with said capacitor placed on the input side of said opto-isolator to provide a voltage drop.

16. Methodology as in claim 15, said method further comprises:

10 configuring selected of the plurality of end devices to relay bi-directional communications between the central collection functionality and others of the plurality of end devices; and

wherein establishing a network further includes:

providing at least one cell relay; and

15 configuring the network such that bi-directional communication between the central collection functionality and selected of the plurality of end devices passes through the at least one cell relay;

whereby bi-directional communication between the central collection functionality and selected of the plurality of end devices is conducted by way of the cell relay while bi-directional communication between the central collection functionality and others of the plurality of end devices is conducted directly; and

20 wherein configuring the network for bi-directional communications includes using an open standard meter communication protocol.

25 17. Methodology as in claim 15, further comprising:

actuating the remote disconnect switch of an electricity meter so as to electrically disconnect or connect the meter line side relative to the meter load side; and

30 subsequently verifying, respectively, that the remote disconnect switch electrically disconnected or connected the meter line side relative to the meter load side.

96164-6T

18. Methodology as in claim 15, further comprising:

actuating the remote disconnect switch of an electricity meter so as to electrically disconnect the meter line side relative to the meter load side; and

5 subsequently identifying possible user fraud by verifying the presence of electricity at the meter load side.

19. Methodology as in claim 15, wherein:

10 the metrology of each electricity meter includes current acquisition circuitry for receiving electrical service current signals, and voltage acquisition circuitry for receiving electrical service voltage signals, with such current acquisition circuitry and voltage acquisition circuitry configured for receiving multi-phase electrical service current and voltage signals, respectively, and such metrology is configured for correction of any monitoring offset relative to electrical service caused by the  
15 presence of the detection circuit in such electricity meter; and

each electricity meter includes at least one communications module configured to effect bi-directional communications between the meter and other networked devices using an open standard meter communication protocol, with such at least one communications module including an additional circuit board dedicated to WAN  
20 connectivity, or one or more of GPRS, Ethernet, and RF LAN communications modules.

20. An advanced metering system with added functionality based on meter load side sensing, comprising:

25 a plurality of end devices, at least some of which end devices comprise electricity meters, each of such electricity meters having a line side for receiving electrical service; a load side, downstream from the meter line side, for electrically connecting with an electrical load; a detection circuit, upstream from the meter load side and downstream from the meter line side, for detecting the presence of  
30 electricity at the meter load side; a remote disconnect switch, upstream from the detection circuit and downstream from the meter line side, for controllably actuating

96164-6T

for electrically connecting and disconnecting the meter line side relative to the meter load side, so that electrical service when present at the meter line side is, respectively, electrically connected with, and disconnected from, an electrical load when present at the meter load side; and metrology, downstream from the meter line side and upstream from the meter load side, for monitoring the consumption or production of electricity vis-à-vis electrical service and electrical load associated with the meter;

5 a network including central collection functionality, and configured for bi-directional communications between the central collection functionality and each of said plurality of end devices, such that data may be communicated across said network regarding actuation of the remote disconnect switch of an electricity meter and presence of electricity at the meter load side thereof;

10 wherein said detection circuit comprises a voltage sensor electrically in parallel with said meter load side, said detection circuit comprising a capacitor, an over-current protection resistor, an opto-isolator, and a transient voltage suppressor for setting the turn-on voltage of said voltage sensor, with said capacitor, said resistor, and said opto-isolator in series and, as a group, in parallel with said meter load side, and with said capacitor placed on the input side of said opto-isolator to provide a voltage drop.

20

21. An advanced metering system as in claim 20, wherein:

selected of said plurality of end devices are configured to relay bi-directional communications between the central collection functionality and others of said plurality of end devices; and

25 wherein said network further includes at least one cell relay, with said bi-directional communication between the central collection functionality and selected of said plurality of end devices passing through the at least one cell relay, whereby bi-directional communication between the central collection functionality and selected of said plurality of end devices is conducted by way of the cell relay while bi-directional communication between the central collection functionality and others of the plurality of end devices is conducted directly; and

30

96164-6T

wherein said network is configured for bi-directional communications includes using an open standard meter communication protocol.

22. An advanced metering system as in claim 20, wherein:

5 each detection circuit of an electricity meter comprises a voltage sensor electrically in parallel with the meter load side, said detection circuit including a filtering capacitor, an over-current protection resistor, an opto-isolator, and a transient voltage suppressor for setting the turn-on voltage of the voltage sensor;

10 the metrology of each electricity meter includes current acquisition circuitry for receiving electrical service current signals, and voltage acquisition circuitry for receiving electrical service voltage signals, with such current acquisition circuitry and voltage acquisition circuitry configured for receiving multi-phase electrical service current and voltage signals, respectively, and such metrology is configured for correction of any monitoring offset relative to electrical service caused by the  
15 presence of the detection circuit in such electricity meter; and

each electricity meter includes at least one communications module configured to effect bi-directional communications between the meter and other networked devices using an open standard meter communication protocol, with such at least one communications module including an additional circuit board dedicated to WAN  
20 connectivity, or one or more of GPRS, Ethernet, and RF LAN communications modules.

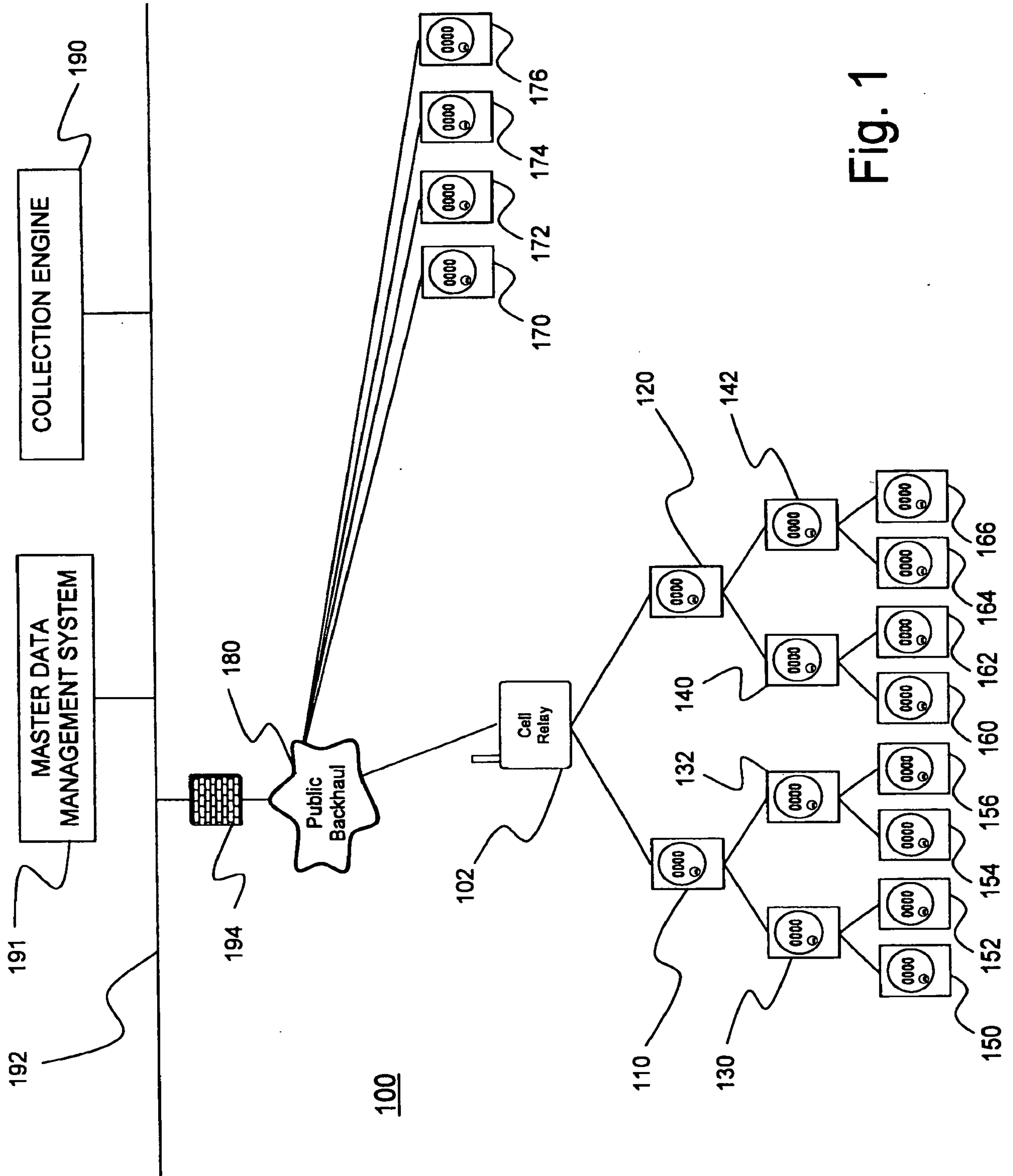

Fig. 1

2/3

Fig. 2

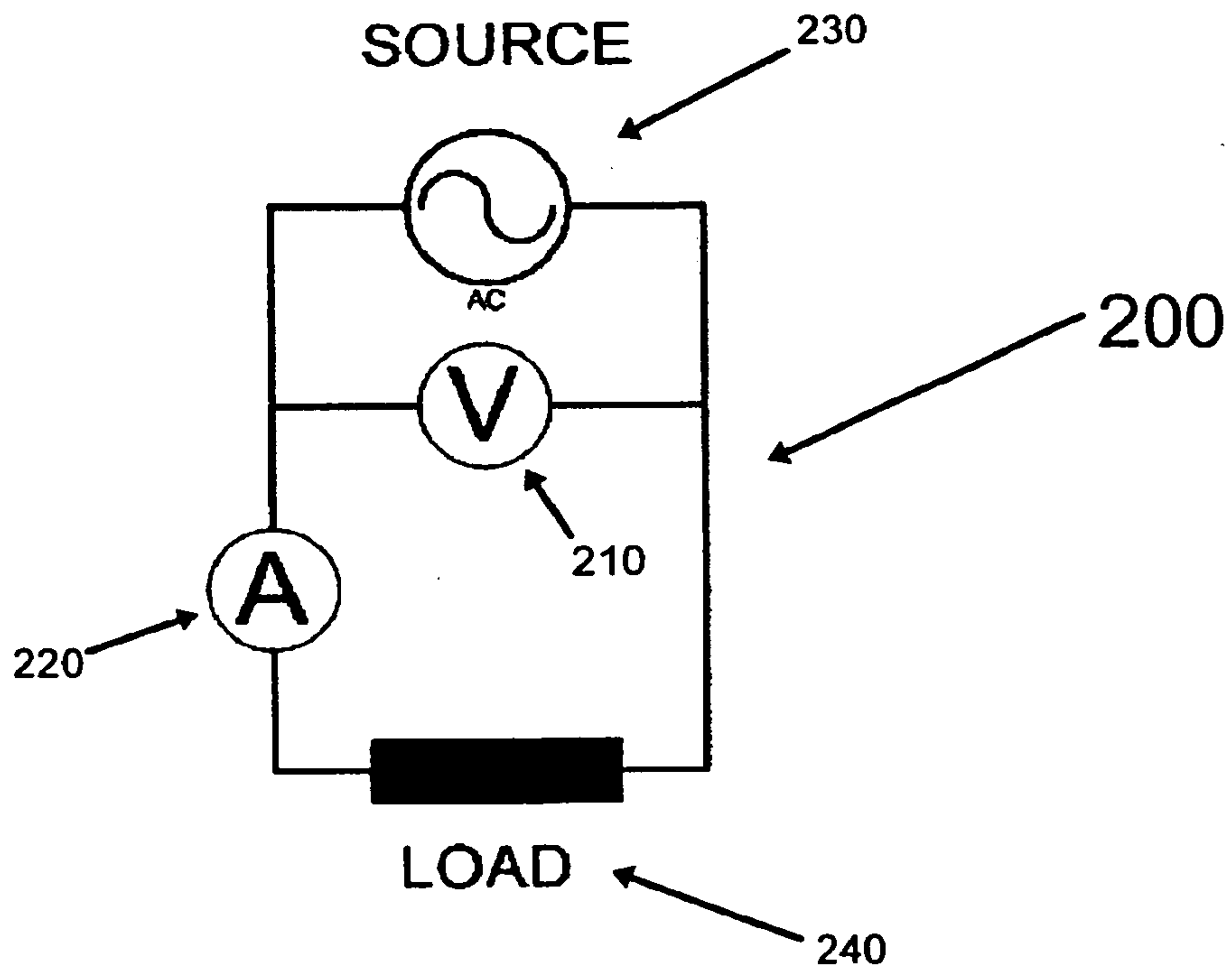
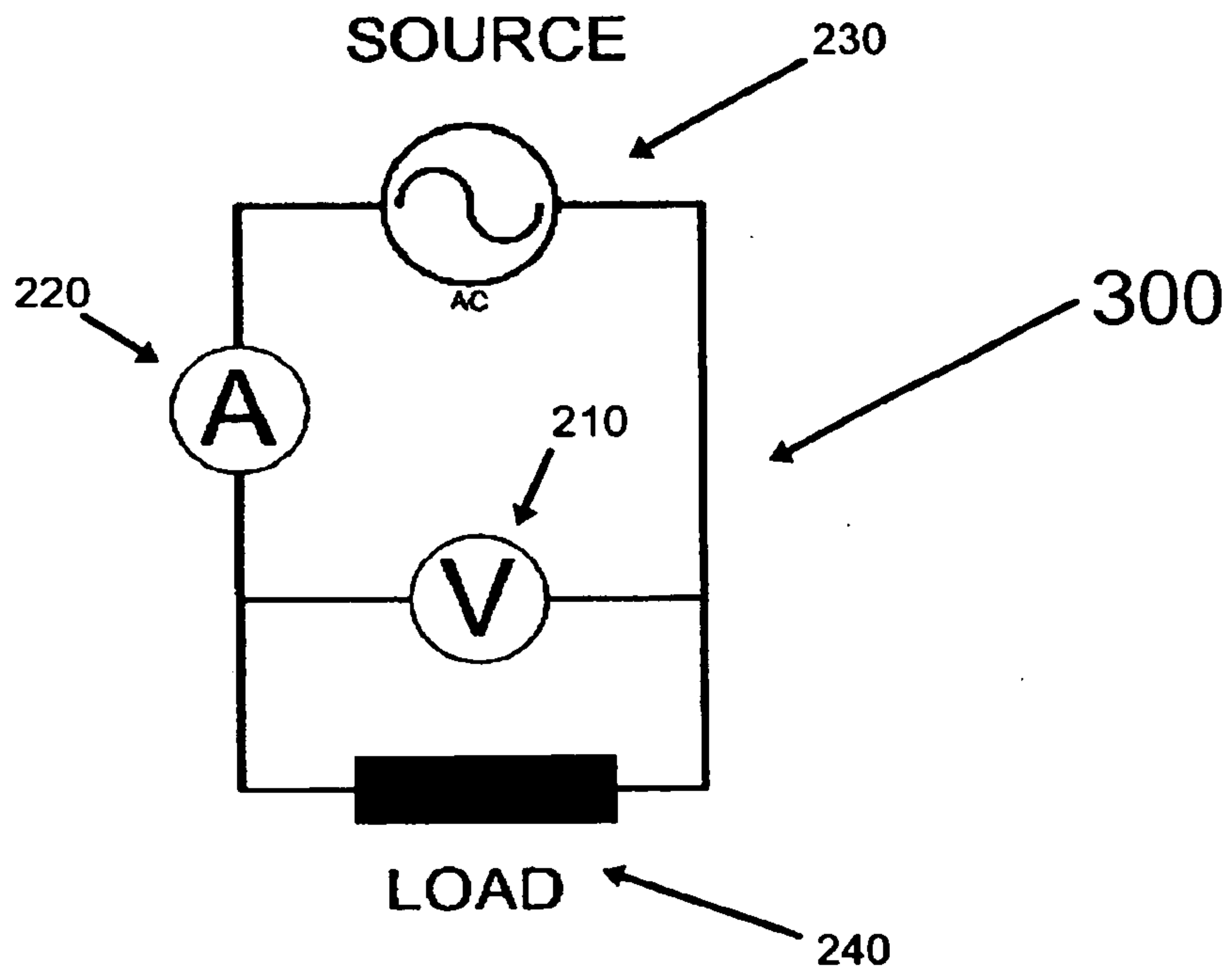

Fig. 3



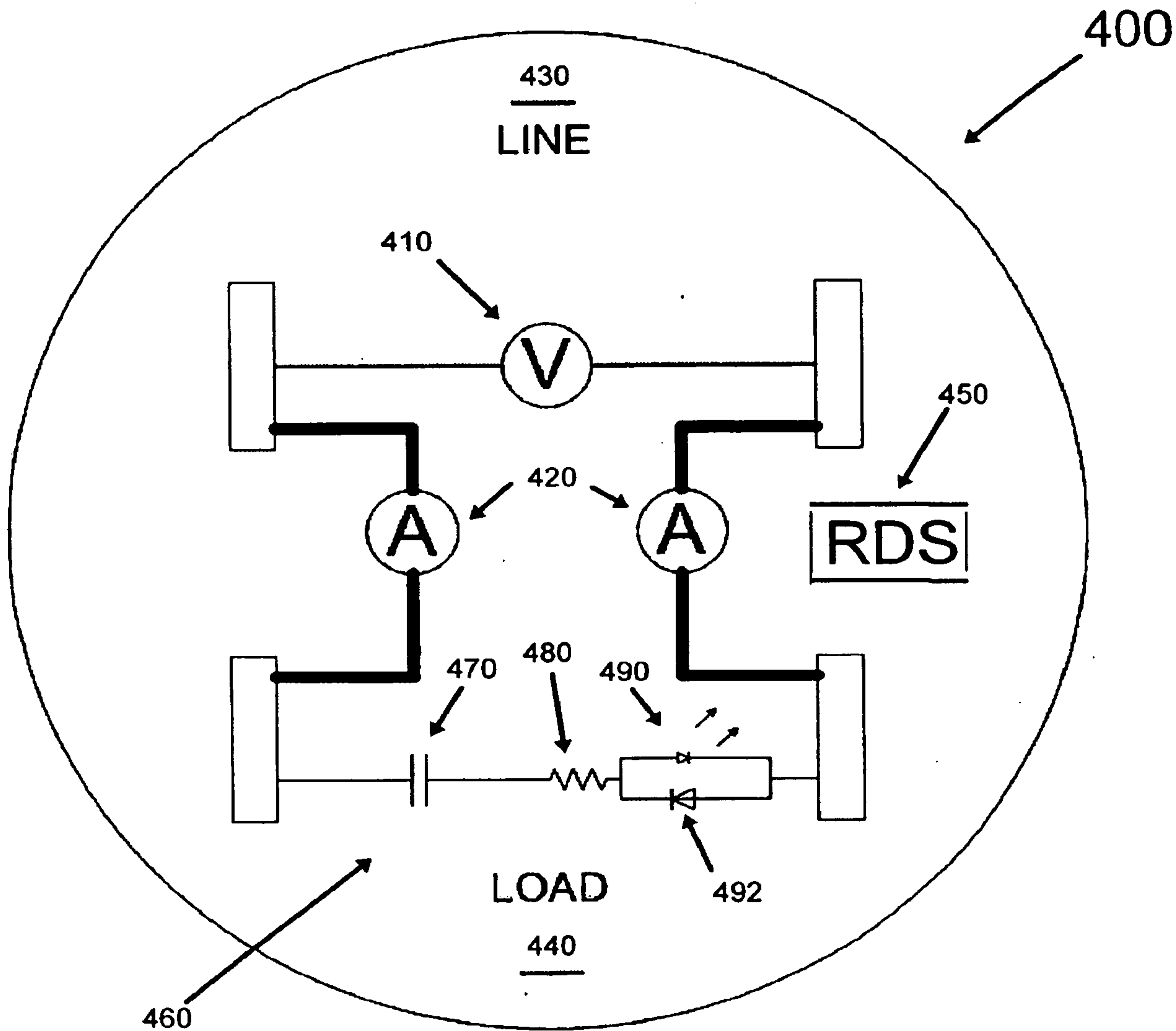

Fig. 4

