



INTERNATIONAL APPLICATION PUBLISHED UNDER THE PATENT COOPERATION TREATY (PCT)

<p>(51) International Patent Classification ⁶ : A61B 17/76</p>	<p>A1</p>	<p>(11) International Publication Number: WO 96/39974 (43) International Publication Date: 19 December 1996 (19.12.96)</p>
<p>(21) International Application Number: PCT/US96/07687 (22) International Filing Date: 24 May 1996 (24.05.96) (30) Priority Data: 08/476,019 7 June 1995 (07.06.95) US (71) Applicant: IMPLEX CORPORATION [US/US]; 80 Commerce Drive, Allendale, NJ 07401-1600 (US). (72) Inventors: COHEN, Robert, C.; 6 Robin Street, Rockaway Township, NJ 07866 (US). CHRISTIE, Michael, J.; 1500 21st South, Nashville, TN 37212 (US). (74) Agent: PLEVY, Arthur, L.; Plevy & Associates, 146 Route 1 North, P.O. Box 1365, Edison, NJ 08818-1366 (US).</p>		<p>(81) Designated States: CA, JP, European patent (AT, BE, CH, DE, DK, ES, FI, FR, GB, GR, IE, IT, LU, MC, NL, PT, SE). Published <i>With international search report.</i> <i>With amended claims.</i></p>

(54) Title: FEMORAL HEAD CORE CHANNEL FILLING PROSTHESIS

(57) Abstract

A prosthesis (10) for interfacing with an internal region of a bone of a given structure and functioning such as a femoral head (42) and/or neck (44), wherein the internal region of the bone can be an avascular necrotic region. The prosthesis comprises a porous filling member for filling a cored channel provided in the internal region of the bone to provide mechanical stability which preserves the function and structure of the bone, and accommodates an ingrowth of healthy vascularized bone tissue into the internal region of the bone. Also, a method for mechanically stabilizing a bone using the prosthesis.

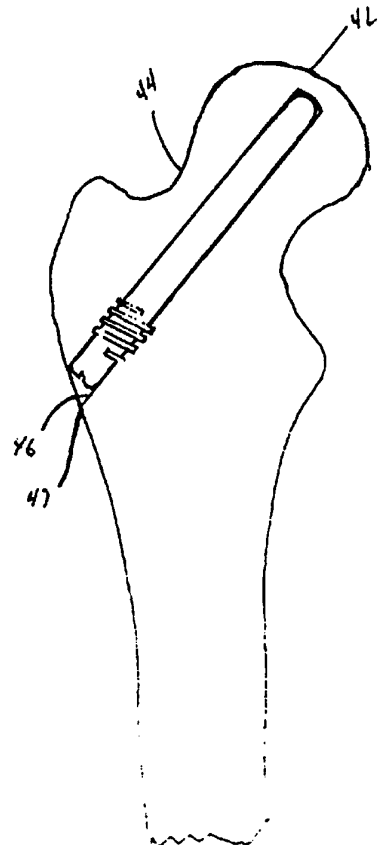

FOR THE PURPOSES OF INFORMATION ONLY

Codes used to identify States party to the PCT on the front pages of pamphlets publishing international applications under the PCT.

AM	Armenia	GB	United Kingdom	MW	Malawi
AT	Austria	GE	Georgia	MX	Mexico
AU	Australia	GN	Guinea	NE	Niger
BB	Barbados	GR	Greece	NL	Netherlands
BE	Belgium	HU	Hungary	NO	Norway
BF	Burkina Faso	IE	Ireland	NZ	New Zealand
BG	Bulgaria	IT	Italy	PL	Poland
BJ	Benin	JP	Japan	PT	Portugal
BR	Brazil	KE	Kenya	RO	Romania
BY	Belarus	KG	Kyrgyzstan	RU	Russian Federation
CA	Canada	KP	Democratic People's Republic of Korea	SD	Sudan
CF	Central African Republic	KR	Republic of Korea	SE	Sweden
CG	Congo	KZ	Kazakhstan	SG	Singapore
CH	Switzerland	LI	Liechtenstein	SI	Slovenia
CI	Côte d'Ivoire	LK	Sri Lanka	SK	Slovakia
CM	Cameroon	LR	Liberia	SN	Senegal
CN	China	LT	Lithuania	SZ	Swaziland
CS	Czechoslovakia	LU	Luxembourg	TD	Chad
CZ	Czech Republic	LV	Latvia	TG	Togo
DE	Germany	MC	Monaco	TJ	Tajikistan
DK	Denmark	MD	Republic of Moldova	TT	Trinidad and Tobago
EE	Estonia	MG	Madagascar	UA	Ukraine
ES	Spain	ML	Mali	UG	Uganda
FI	Finland	MN	Mongolia	US	United States of America
FR	France	MR	Mauritania	UZ	Uzbekistan
GA	Gabon			VN	Viet Nam

FEMORAL HEAD CORE CHANNEL FILLING PROSTHESIS**TECHNICAL FIELD OF THE INVENTION**

This invention relates generally to a bone prosthesis and more particularly, to a bone prosthesis used in the treatment of avascular necrosis of the femoral head.

5

BACKGROUND ART

Up to 20,000 people in the United States develop avascular necrosis of the femoral head each year. Avascular necrosis of the femoral head develops when the blood supply to the femoral head is interrupted. The interruption can be the result of many factors, some of which are unknown, however, whatever the cause, the disease is degenerative. Thus, over a period of time, the rate of viable bone resorption in the secondary degenerative stages of the disease will lead to femoral head and/or neck collapse and fracture. When this occurs, hip reconstructive surgery becomes necessary.

10

15

Accordingly, it is desirable to delay or avoid the need for total hip replacement surgery by performing other less radical surgical procedures that are available today. It is generally agreed that the recommended time for performing these less radical surgical procedures is in the early stages of the disease. In the early stages of avascular necrosis, the femoral head has not structurally failed and typically displays no signs of any radiographic crescent images or subchondral lucency. In particular, the pathological process in the early stages of the disease, is confined to a wedge-shaped area of necrosis in

20

25

the superior weight-bearing portion of the femoral head. This area is subject to collapse and fracture at the junction of the living and dead bone at the level of the "creeping substitution."

5 A common surgical procedure that is presently used prior to collapse and fracture of the femoral head and/or neck in an effort to delay or avoid hip reconstructive surgery, is core decompression. This procedure is generally implemented to preserve the function and the 10 structure of the femoral head and/or neck and to relieve the debilitating pain associated with the disease.

Core decompression involves repairing the necrotic area by coring and, optionally, filling the cored area with a bone graft. More specifically, core decompression 15 involves a technique wherein through a lateral trochanteric approach, an 8 to 10 mm cylindrical core of bone is removed from the anterolateral segment of the femoral head which creates an open cylindrical channel therein. The open channel operates to relieve pressure and provides a conduit for biological functions which 20 assist in repairing the bone. Optionally, the open channel in the femoral head can be filled with either a vascularized or a non-vascularized bone graft. Vascularized bone grafts are used in an attempt to assist 25 in the ingrowth of vascular cellular tissue into the necrotic area to enhance revascularization thereof in order to arrest the progression of the necrosis. Non-vascularized "cortical" bone grafts are used in an attempt to provide some structural stability to the femoral head and/or neck during the healing process. Unfortunately, 30 due to the existence of problems associated with inaccurate matching of the open channel and the quality of

these bone grafts, collapse of the necrotic area still often occurs.

In an attempt to provide additional structural stability to the femoral head and/or neck, the prior art
5 has provided solid metal drills or threaded pins which are implanted in the femoral head. However, due to the relative minor diameter of these drills and pins and their inherent lack of any biological interface characteristics, collapse and fracture of the femoral head and/or neck
10 still commonly occurs.

Furthermore, major complications are associated with core decompression. For example, collapse of the femoral wedge-shaped area of necrosis occurs from the lack of bony structural support and the continuing degenerative changes
15 caused by the disease. Thus, the objective of preserving the function and structure of the femoral head and/or neck by performing a core decompression and filling the open channel with a bone graft remains unfulfilled.

It is, therefore, a primary object of the present
20 invention to provide a bone core channel filling prosthesis which mechanically stabilizes the femoral head and/or neck.

It is a further object of the present invention to provide a bone core channel filling prosthesis which
25 enables the ingrowth of vascular cellular tissue into a necrotic region of the bone to enhance revascularization and slow the progression of the necrosis.

DISCLOSURE OF THE INVENTION

30 A prosthesis for interfacing with an internal region of a bone of a given structure and function such as a femoral head and/or neck, wherein the internal region of the bone can be an avascular necrotic region. The

prosthesis comprises porous filling means for filling a cored channel provided in the bone, whereby the porous filling means provides mechanical stability which preserves the function and the structure of the bone while also accommodating an ingrowth of healthy vascularized bone tissue into the internal bone region in instances where the internal bone region is an avascular necrotic region of the bone.

The present invention also describes a method for mechanically stabilizing a femoral head to substantially prevent the femoral head from collapsing and fracturing. The method comprises removing a core of bone from an anterolateral segment of the femoral head to provide an open channel therein. Next, the open channel is filled by inserting the filling prosthesis of the present invention.

BRIEF DESCRIPTION OF THE DRAWINGS

The novel features of the present invention will become apparent from the following detailed description of the invention illustrated in the accompanying drawings, wherein:

FIG. 1A is an elevational view of an exemplary embodiment of the filling prosthesis of the present invention;

FIG. 1B is a cross-sectional view of the filling prosthesis of FIG. 1A;

FIG. 1C is a elevational view from the second end of the filling prosthesis shown in FIGS. 1A and 1B; and

FIG. 2 depicts the filling prosthesis of FIGS. 1A-1C implanted into a cored channel made in the femoral head.

BEST MODE FOR CARRYING OUT THE INVENTION

The present invention relates to a bone core channel filling prosthesis and method for implanting same.

5 Although the present invention is especially suited for use in core channels created by a core decompression of the femoral head, persons of ordinary skill in the art will recognized that the present invention can be used as a bone core channel filling prosthesis in any other type
10 of bone or clinical indication.

Referring to FIG. 1A, there is shown an exemplary preferred embodiment of the bone core channel filling prosthesis made in accordance with the present invention designated by the numeral 10. The filling prosthesis 10
15 comprises a machined cylindrical rod-shaped member 12 having a first end 14 and a second end 16. The rod-shaped member 12 has a preferred diameter of approximately 10 mm and a preferred length of approximately 100 mm. One of ordinary skill in the art will recognize, however, that in
20 order to accommodate a broad patient population, the rod-shaped member can also be manufactured in other diameters and length combinations.

The filling prosthesis 10 includes fixation means for affixing the prosthesis within the core channel. In the
25 preferred embodiment shown, the fixation means comprises a single helical thread 18 having approximately four 360° thread rotations, disposed on the outer surface of the rod-shaped member 12. As shown in FIG. 1B, the thread 18 defines a major diameter 20 of approximately 12 mm and a
30 minor diameter 22 of approximately 10 mm. The pitch 24 of the thread 18 is approximately 3 mm. Each thread rotation includes a substantially flat inclined leading face 26, a substantially flat inclined trailing face 28, a

substantially flat crest 30 and a substantially flat root 32. The inclined leading face 26 and the inclined trailing face 28 define an angle 34 of approximately 30.0°. The trailing end of the thread 18 starts approximately 10 mm from the second end 16 of the rod-shaped member 12 and extends therealong approximately 20 mm. The thread 18 of the filling device 10 cuts into the wall of the core channel 46 as shown in FIG. 2, to provide immediate intraoperative stability to the femoral head 42 and neck 44 and to prevent the filling prosthesis 10 from dislodging from the core channel 46.

Referring again to FIG. 1A, the first end 14 of the rod-shaped member 12 has a full spherical radius 36 which allows the first end 14 of the rod-shaped member 12 to be easily inserted into the core channel to reside in the femoral head. The second end 16 of the rod-shaped member 12 includes turning means for screwing the filling prosthesis 10 into its final seating position in the core channel of the femoral head. In the preferred embodiment shown, the turning means comprises a slot 38 which extends diametrically along the second end of the rod-shaped member 12 and a pair of opposing recesses 40 as best seen in FIGS 1A and 1C. The slot 38 and the pair of opposing recesses 40 are adapted to receive a filling prosthesis driving tool (not shown).

The filling prosthesis 10 described above, should be made from a highly porous material having a structure of interconnecting pores which accommodates tissue ingrowth, revascularization and deposition of new bone. The material chosen should allow for accurate machining to enable the filling prosthesis to properly fill the cored channel.

The use of a material having a volumetrically large porous structure is important in the present invention because such a structure is complimentary to the microstructure of natural cancellous bone and thus, enables the filling prosthesis 10 of the present invention to operate as a matrix for the biological ingrowth of bone. The porous structure of the filling device of the present invention, operates as a conduit from the healthy, vascularized bone into the avascularized bone of the necrotic area. The pores of the filling prosthesis 10 should form a three dimensional network of continuously connected never-ending channels which define a bulk volume porosity of approximately 50-90 percent and preferably greater than 80 percent. Such a network provides optimal permeability and a high surface area which encourages tissue ingrowth, vascularization, and deposition of new bone. The material used in the present invention should also have a high corrosion and crack resistance, and be biocompatible.

In the preferred embodiment of the present invention, the filling prosthesis is made from an open-celled lattice tantalum-carbon composite material available from Implex Corporation, the assignee herein, under the tradename HEDROCEL. HEDROCEL is well known in the art as a composite of reticulated vitreous carbon foam and tantalum metal. The tantalum metal provides the carbon foam with the requisite mechanical properties which the carbon foam does not, by itself, possess. The composite is made by applying tantalum metal to a reticulated vitreous carbon foam construct in a chemical vapor infiltration process (CVI), which is a variation of chemical vapor deposition (CVD). Tantalum has a long history of use as an implant material in bone tissue since it possesses good mechanical

a properties, excellent corrosion resistance and demonstrated biocompatibility.

The following method viewed in conduction with FIG. 2, describes how the filling prosthesis of the present invention is used to treat a necrotic region in the femoral head 42. The method comprises removing a core of bone from an anterolateral segment of the femoral head 42 to provide an open channel 46 therein. The first end 14 of the filling prosthesis 10 of the present invention is then inserted into the open channel 46 until the threads 18 contact the external lateral femoral bone 47. Then, a filling prosthesis driving tool (not shown) is used to turn the filling prosthesis into its final position in the bone as depicted in FIG. 2. In hard bone, a tapping instrument can be used in a preparation to receive the threads of the filling prosthesis.

The filling prosthesis of the present invention overcomes the problems associated with the bone grafting techniques described earlier which provide insufficient structural stability to the bone. Further, the filling prosthesis of the present invention possesses the needed biological interface characteristics that are lacking in the prior art solid metal drills and threaded pins.

It should be understood that the embodiment described herein is merely exemplary and that a person skilled in the art may make many variations and modifications to the embodiment utilizing functionally equivalent elements to those described herein. Any and all such variations or modifications as well as others which may become apparent to those skilled in the art, are intended to be included within the scope of the invention as defined by the appended claims.

CLAIMS

I/we claim:

1. A prosthesis for interfacing with an internal region of a bone of a given structure and function, comprising:

porous filling means for filling a cored channel provided in the internal region of the bone, whereby said porous filling means provides mechanical stability which preserves the function and the structure of the bone and accommodates an ingrowth of healthy vascularized bone tissue into the internal region of the bone.

2. The prosthesis according to claim 1, wherein the internal region is an avascularized necrotic region of the bone and said porous filling means comprises a volumetrically large porous structure of interconnecting pores that operate as conduits which allow the healthy vascularized bone tissue to pass into the avascular necrotic region of the bone.

3. The prosthesis according to claim 1, wherein said porous filling means comprises a bulk volume porosity between approximately 50 and 90 percent.

4. The prosthesis according to claim 1, wherein said porous filling means comprises a reticulated vitreous carbon foam having tantalum deposited thereon.

5. The prosthesis according to claim 1, wherein the bone comprises a femoral head.

6. The prosthesis according to claim 1, wherein said porous filling means comprises a rod-shaped member having a first end and a second end.

7. The prosthesis according to claim 6, wherein said rod-shaped member includes a thread.

8. The prosthesis according to claim 7, wherein said thread is located marginally adjacent to said second end.

9. The prosthesis according to claim 8, wherein said thread has a pitch of approximately 3 mm and substantially flat roots and crests.

10. The prosthesis according to claim 6, wherein said first end of said rod-shaped member comprises a spherical-shape.

11. The prosthesis according to claim 6, wherein said second end of said rod-shaped member comprises means for driving said device into the cored hole of the bone.

12. A core channel filling prosthesis for interfacing with an internal region of a femoral head to substantially prevent the femoral head from collapsing and fracturing, comprising:

a porous rod-shaped member having a first end and second end for filling a cored channel provided in the internal region of the bone, said porous member having a volumetrically large structure of interconnecting pores which operate as conduits which allow healthy vascularized

bone tissue to pass into the internal region of the femoral head, whereby said prosthesis provides mechanical stability which preserves the function and the structure of the femoral head.

13. The prosthesis according to claim 12, wherein said porous rod-shaped member includes a thread located marginally adjacent to said second end.

14. The prosthesis according to claim 13, wherein said thread has a pitch of approximately 3 mm and substantially flat roots and crests.

15. The prosthesis according to claim 14, wherein said first end of said porous rod-shaped member comprises a spherical-shape and said second end of said rod-shaped member comprises means for driving said device into the cored channel of the femoral head.

16. The prosthesis according to claim 13, wherein said porous rod-shaped member comprises a bulk volume porosity of between approximately 50-90 percent.

17. The prosthesis according to claim 13, wherein said porous rod-shaped member comprises a reticulate vitreous carbon foam having tantalum deposited thereon.

18. The prosthesis according to claim 12, wherein said internal region is an avascularized necrotic region of the bone.

19. A method for mechanically stabilizing a femoral head to substantially prevent said femoral head from collapsing and fracturing, comprising the steps of:

removing a core of bone from an anterolateral segment of said femoral head to provide an open channel therein; and

filling said open channel with a porous rod-shaped member having a first end, a second end and a volumetrically large porous structure of interconnecting pores that operate as conduits which allow healthy vascularized bone tissue to pass into said avascular necrotic region of said femoral head, whereby said porous rod-shaped member provides mechanical stability which preserves the function and the structure of said femoral head.

20. The method according to claim 19, wherein said first end of said porous rod-shaped member comprises a spherical-shape and said second end of said rod-shaped member comprises means for driving said device into said open channel, said step of filling includes the steps of:

inserting said spherical-shaped first end of said porous rod-shaped member into said open channel; and driving said porous rod-shaped member into said open channel with said driving means of said second end.

21. The method according to claim 20, wherein said porous rod-shaped member includes a thread located marginally adjacent to said second end.

22. The method according to claim 19, wherein said porous rod-shaped member comprises a bulk volume porosity of between approximately 50 and 90 percent.

23. The method according to claim 19, wherein said porous rod-shaped member comprises a reticulated vitreous carbon foam having tantalum deposited thereon.

AMENDED CLAIMS

[received by the International Bureau on 3 September 1996 (03.09.96);
original claims 1-23 replaced by amended claims 1-19 (4 pages)]

1. A prosthesis for interfacing with an internal region of a femoral bone, comprising:
porous filling means for filling a cored channel provided in the internal region of a femoral head, said porous filling means comprising a unitarily formed rod-shaped member of reticulated vitreous carbon foam having tantalum deposited thereon, whereby said porous filling means provides mechanical stability which preserves the function and the structure of the bone and accommodates an ingrowth of healthy vascularized bone tissue into the internal region of the bone.
2. The prosthesis according to claim 1, wherein the internal region is an avascularized necrotic region of said femoral head and said porous filling means comprises a volumetrically large porous structure of interconnecting pores that operate as conduits which allow the healthy vascularized bone tissue to pass into the avascular necrotic region of the bone.
3. The prosthesis according to claim 1, wherein said porous filling means comprises a bulk volume porosity between approximately 50 and 90 percent.
4. The prosthesis according to claim 1, wherein said unitarily formed rod-shaped member has a first end and a second end.
5. The prosthesis according to claim 4, wherein said rod-shaped member includes a thread.
6. The prosthesis according to claim 5, wherein said thread is located marginally adjacent to said second end.

7. The prosthesis according to claim 6, wherein said thread has a pitch of approximately 3 mm and substantially flat roots and crests.

8. The prosthesis according to claim 4, wherein said first end of said rod-shaped member comprises a spherical-shape.

9. The prosthesis according to claim 4, wherein said second end of said rod-shaped member comprises means for driving said device into the cored hole of the bone.

10. A core channel filling prosthesis for interfacing with an internal region of a femoral head to substantially prevent the femoral head from collapsing and fracturing, comprising:

a unitarily formed porous rod-shaped member having a first end and second end for filling a cored channel provided in the internal region of a femoral head, said porous member comprising reticulate vitreous carbon foam having tantalum deposited thereon, said foam forming a volumetrically large structure of interconnecting pores which operate as conduits which allow healthy vascularized bone tissue to pass into the internal region of the femoral head, whereby said prosthesis provides mechanical stability which preserves the function and the structure of the femoral head.

11. The prosthesis according to claim 10, wherein said porous rod-shaped member includes a thread located marginally adjacent to said second end.

12. The prosthesis according to claim 11, wherein said thread has a pitch of approximately 3 mm and substantially flat roots and crests.

13. The prosthesis according to claim 12, wherein said first end of said porous rod-shaped member comprises a spherical-shape and said second end of said rod-shaped member comprises means for driving said device into the cored channel of the femoral head.

14. The prosthesis according to claim 11, wherein said porous rod-shaped member comprises a bulk volume porosity of between approximately 50-90 percent.

15. The prosthesis according to claim 10, wherein said internal region is an avascularized necrotic region of the bone.

16. A method for mechanically stabilizing a femoral head to substantially prevent said femoral head from collapsing and fracturing, comprising the steps of:

removing a core of bone from an anterolateral segment of said femoral head to provide an open channel therein; and

filling said open channel with a unitarily formed porous rod-shaped member having a first end, a second end and a volumetrically large porous structure comprising reticulated vitreous carbon foam having tantalum deposited thereon which forms interconnecting pores that operate as conduits which allow healthy vascularized bone tissue to pass into said avascular necrotic region of said femoral head, whereby said porous rod-shaped member provides mechanical stability which preserves the function and the structure of said femoral head.

17. The method according to claim 16, wherein said first end of said porous rod-shaped member comprises a spherical-shape and said second end of said rod-shaped member comprises means for driving said device into said open channel, said step of filling includes the steps of:

inserting said spherical-shaped first end of said porous rod-shaped member into said open channel;
and

driving said porous rod-shaped member into said open channel with said driving means of said second end.

18. The method according to claim 17, wherein said porous rod-shaped member includes a thread located marginally adjacent to said second end.

19. The method according to claim 16, wherein said porous rod-shaped member comprises a bulk volume porosity of between approximately 50 and 90 percent.

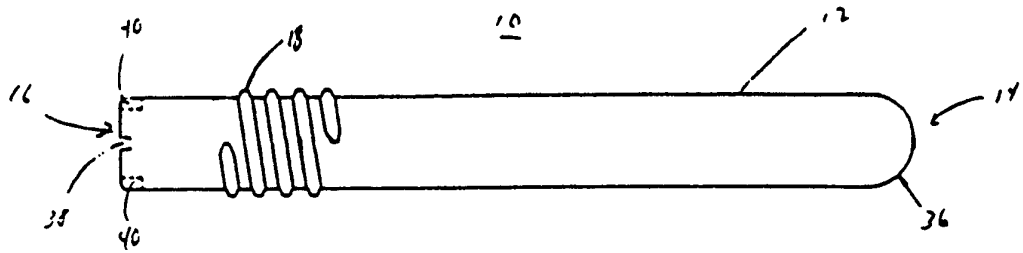

FIG. 1A

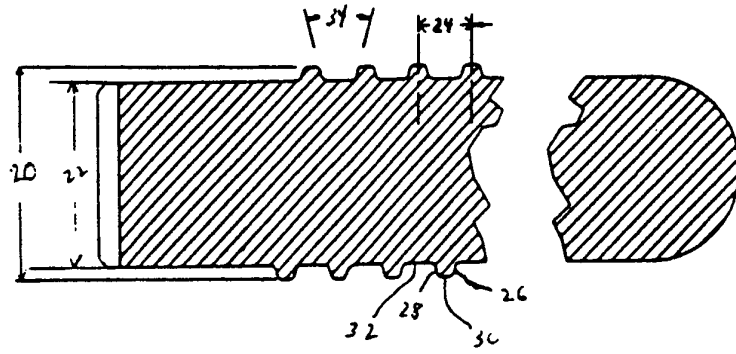

FIG. 1B

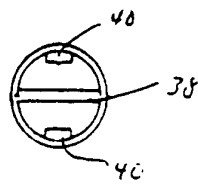

FIG. 1C

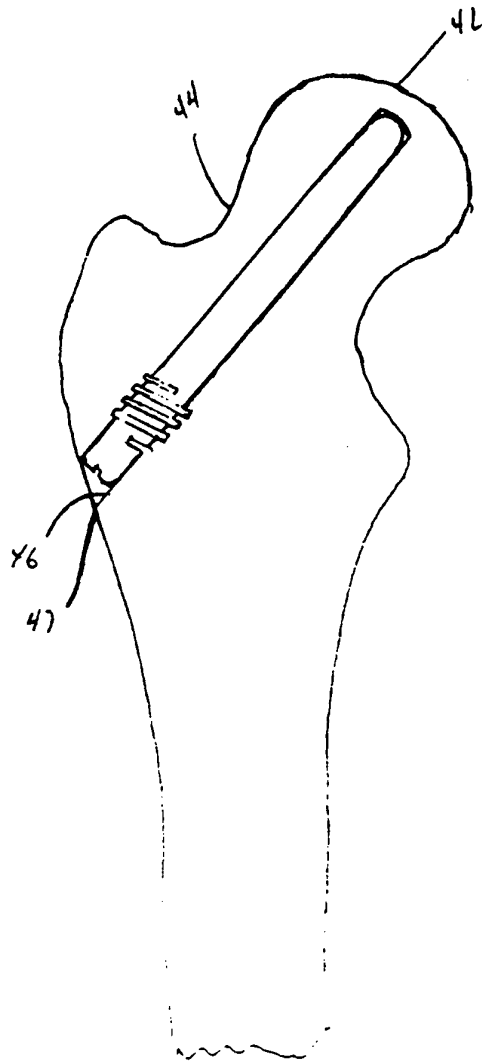

FIG. 2

INTERNATIONAL SEARCH REPORT

International application No.
PCT/US96/07687

A. CLASSIFICATION OF SUBJECT MATTER

IPC(6) :A61B 17/76
US CL :606/65

According to International Patent Classification (IPC) or to both national classification and IPC

B. FIELDS SEARCHED

Minimum documentation searched (classification system followed by classification symbols)

U.S. : 606/65, 76

Documentation searched other than minimum documentation to the extent that such documents are included in the fields searched

Electronic data base consulted during the international search (name of data base and, where practicable, search terms used)

APS

Search Terms: carbon, fiberglass, tantalum

C. DOCUMENTS CONSIDERED TO BE RELEVANT

Category*	Citation of document, with indication, where appropriate, of the relevant passages	Relevant to claim No.
X	US, A, 3,852,045, (WHEELER ET AL.) 03 December 1974, see column 4 lines 21-24, column 6 lines 7-11. column 7 lines 31 and 44, column 9 lines 48-57, column 10 line 68, through column 11 line 5, column 16 lines 41 and 42, and Table II.	1-3, 5-8, 12, 13, 16, 18
X	US, A, 4,259,072 (HIRAHAYASHI ET AL.) 31 March 1981, see column 2 lines 2-4, column 4 lines 32-34, and the figures.	1-3, 5-16, 18
X	US, A, 5,282,861 (KAPLAN) 01 February 1994, see entire document.	1-6, 12
---		-----
Y		17
Y	WO, A, 92/15257 (ASNIS ET AL.) 17 September 1992, see figures.	19-23

Further documents are listed in the continuation of Box C. See patent family annex.

* Special categories of cited documents:	*T	later document published after the international filing date or priority date and not in conflict with the application but cited to understand the principle or theory underlying the invention
*A document defining the general state of the art which is not considered to be part of particular relevance	*X	document of particular relevance; the claimed invention cannot be considered novel or cannot be considered to involve an inventive step when the document is taken alone
*E earlier document published on or after the international filing date	*Y	document of particular relevance; the claimed invention cannot be considered to involve an inventive step when the document is combined with one or more other such documents, such combination being obvious to a person skilled in the art
*L document which may throw doubts on priority claim(s) or which is cited to establish the publication date of another citation or other special reason (as specified)	*G	document member of the same patent family
*O document referring to an oral disclosure, use, exhibition or other means		
*P document published prior to the international filing date but later than the priority date claimed		

Date of the actual completion of the international search

22 JULY 1996

Date of mailing of the international search report

14 AUG 1996

Name and mailing address of the ISA/US
Commissioner of Patents and Trademarks
Box PCT
Washington, D.C. 20231

Facsimile No. (703) 305-3590

Authorized officer

DAVID H. WILLSE

Telephone No. (703) 308-2903