

(19)



(11)

EP 2 620 183 B1

(12)

EUROPEAN PATENT SPECIFICATION

(45) Date of publication and mention of the grant of the patent:
18.09.2019 Bulletin 2019/38

(51) Int Cl.:
A62C 13/76 (2006.01)

(21) Application number: **12195557.9**

(22) Date of filing: **04.12.2012**

(54) Fire extinguisher safety mechanism

Sicherheitsmechanismus für einen Feuerlöscher

Mécanisme de sécurité pour un extincteur d'incendie.

(84) Designated Contracting States:
AL AT BE BG CH CY CZ DE DK EE ES FI FR GB GR HR HU IE IS IT LI LT LU LV MC MK MT NL NO PL PT RO RS SE SI SK SM TR

(30) Priority: **06.12.2011 GB 201120907**

(43) Date of publication of application:
31.07.2013 Bulletin 2013/31

(60) Divisional application:
18188594.8 / 3 421 104

(73) Proprietor: **UTC CCS Manufacturing Polska Sp. z o.o.**
39-100 Ropczyce (PL)

(72) Inventors:
• **May, John James**
Kenilworth, Warwickshire CV8 1BS (GB)

- **Fernandes, Mark Anthony John**
Learnington Spa, Warwickshire CV32 6EW (GB)
- **Rutter, Paul Benedict**
Warwick, Warwickshire CV34 4UJ (GB)
- **Fletcher, Peter George**
Chobham, Surrey GU24 8HD (GB)
- **Fergusson, Chris John**
Burton on Trent, Staffordshire DE15 9HL (GB)

(74) Representative: **Dehns**
St. Bride's House
10 Salisbury Square
London EC4Y 8JD (GB)

(56) References cited:
GB-A- 1 566 815 GB-A- 2 322 298
JP-U- S5 059 894

EP 2 620 183 B1

Note: Within nine months of the publication of the mention of the grant of the European patent in the European Patent Bulletin, any person may give notice to the European Patent Office of opposition to that patent, in accordance with the Implementing Regulations. Notice of opposition shall not be deemed to have been filed until the opposition fee has been paid. (Art. 99(1) European Patent Convention).

Description

FIELD OF INVENTION

[0001] The present invention relates to fire extinguishers and in particular to fire extinguisher safety mechanisms.

BACKGROUND

[0002] Fire extinguishers frequently include a safety mechanism which prevents accidental discharge of the extinguisher. One such mechanism comprises a pin which extends through the handle of the extinguisher. The pin has a handle at one end which can be pulled by a user when he or she wishes to use the extinguisher. The pulling action breaks a part of the pin allowing it to be withdrawn from the extinguisher handle and allowing the extinguisher then to be used. The broken pin also indicates that the extinguisher has been used. An example of such an extinguisher is disclosed in US-A-3844356.

[0003] In a similar system, the end of the pin remote from the pin handle is provided with a weakened head which engages a pronged opening in a seal. When the pin is withdrawn the seal breaks, allowing the pin to be withdrawn and the extinguisher to be used. The damaged caused to the seal indicates that the extinguisher has been used. Such a system is disclosed in US-A-3 666 016.

[0004] In a variation on that design, the end of a pin remote from the pin handle is weakened such that when it is pulled from the extinguisher it breaks, allowing an indicator member to fall away. This indicates that the extinguisher has been used. This type of design has been used by the Applicant for some 20 years.

[0005] A problem with such designs is that the pin handle projects from one side of the extinguisher body, i.e. it is a "handed" arrangement which may be inconvenient for a user. A further problem is that the pin breaks in tension which may make construction of the pin more difficult or breaking of the pin more difficult.

[0006] The present invention seeks to overcome or at least mitigate the above problems.

[0007] GB 2322298 A discloses a fire extinguisher safety mechanism having the features of the preamble of claim 1. JP S50 59894 U discloses an indicator for a fire extinguisher safety mechanism.

SUMMARY

[0008] The present invention provides a fire extinguisher safety mechanism. The mechanism as set forth in claim 1.

[0009] In accordance with the disclosure, therefore, rather than a user operating the extinguisher by pulling a release mechanism from one side of the extinguisher, the user pulls a release member lengthwise from be-

tween the handles. Pulling the release member in this manner will cause the shank of the indicator member to shear, allowing the release member to be removed from between the handles. One of the handles can then be moved relative to the other to operate the extinguisher. The indicator member will no longer be retained and will simply fall away indicating that the extinguisher has been used. As its shank has been sheared, it cannot be used again.

[0010] The head of the indicator member may be relatively thin and may for example be disc like. It may be circular in shape or have any desired shape, for example a polygonal shape.

[0011] The head may carry an inscription, for example "OK", to indicate that the extinguisher has not been used.

[0012] To enhance visibility of the indicator member in low light conditions, the indicator member may be brightly coloured. It may be made from a fluorescent, phosphorescent, luminescent or other 'glow in the dark' material. The colour of the indicator may be varied to, for example, indicate its year of manufacture or servicing of the extinguisher, thereby giving the user an indication of the period in which the extinguisher has not been operated. Up to 20 wt% of a coloured and/or luminous additive may be added to the material of the indicator.

[0013] The indicator member may be moulded from a plastics material, for example a polystyrene material. The material should desirably be chosen such that the shank of the indicator member shears without excessive strain, i.e. such that it does not stretch excessively. If the material stretches, it will break in tension rather than in shear which is undesirable since the force required to break the shank would typically be twice as high in tension as in shear. A desirable breaking force in some applications is less than 100N, for example below 80N.

[0014] To provide the requisite material properties, regrind (particularly of the same material of the virgin material) may be added to the virgin material. This reduces the strength of the virgin material. In one example, between 2-10 wt% regrind, more narrowly 4-6 wt%, for example 5% regrind may be used. A material which has proven particularly suitable is EDISTIR N1840, with 5 wt% EDISTIR N1840 regrind.

[0015] The indicator member head may be configured to be received by a complementary area provided on the extinguisher head, more particularly an area on the movable handle of the extinguisher. That area may carry an inscription such as "USED" which becomes visible once the indicator member head has fallen away, thereby indicating that the extinguisher has been used. The inscription may be embossed, printed or otherwise provided on the extinguisher head.

[0016] In order to facilitate shearing of the indicator member shank, the shank may be provided with one or more areas of weakness. This area of weakness may be in an intermediate region of the shank.

[0017] In one arrangement, the shank is provided with a through hole which effectively reduces the thickness

of the shank. Other arrangements are possible, however, for example a waisting of the shank in the region of its engagement with the release member. In one arrangement, a though hole may be provided in a waisted region of the shank. This not only reduces the force necessary to shear the shank but also to improve flow of material in the mould during the moulding of the indicator member.

[0018] The shank may be stepped in order to provide a first region for engaging in the aperture provided in the extinguisher head and a second region, smaller in cross section than the first region, for engaging in the aperture provided in the release member.

[0019] In another embodiment, however, a proximal portion of the shank adjacent the head may taper towards the distal end of the shank. This avoids a columnar shank which potentially could be reinserted in the aperture in the extinguisher head after use, which is undesirable.

[0020] The resilient retaining means provided on the distal end of the shank may be barb-like, for example formed on the ends of flexible legs formed by a slot in the distal end of the shank. The barbs prevent the indicator member being withdrawn from the release member once the indicator member has been inserted.

[0021] The distal end of the shank may have a profile which is at least in part complementary to that of the aperture in the distal end of the release member. This is advantageous in that it helps locate the indicator in the release member and reduces twisting of the shank as the release member is withdrawn, thereby reducing the chances of the shank breaking in tension rather than in shear.

[0022] In the arrangement described immediately above, the lateral surfaces of the flexible legs of the retaining means may be formed as flat surfaces, particularly parallel flat surfaces, to cooperate with complementary surface in the aperture in the release member.

[0023] Alignment means may be provided to align the indicator member in an appropriate orientation on the extinguisher, so that, for example, any inscription is easily readable by a user. In one arrangement, the rear surface of the head of the indicator member is provided with a formation, for example one or more projections which engages with a corresponding formation on the extinguisher. In one example, the rear surface of the head is provided with a rib which engages under the lower edge of the handle to which the indicator member is mounted.

[0024] As discussed above, once the extinguisher has been used the indicator member is broken and, once the extinguisher is re-charged, must be replaced.

[0025] Turning to the release member, the proximal end thereof may comprise an aperture through which a user may place one or more fingers to pull the release member from between the extinguisher handles.

[0026] The distal end of the release member may be provided with a clip for engaging a part of the extinguisher handle or a part of the extinguisher valve mechanism to assist in retaining the release member in position. This may take some load off the shank of the indicator member

in the event of a force being applied accidentally to the release member.

[0027] As discussed above, the aperture in the distal end of the release member may be at least in part complementary in shape to the distal end of the indicator shank.

[0028] The distal end of the release member may be provided with a boss, offset from the main plane of the release member. The boss is provided with the aperture for receiving the shank of the indicator member. This may allow the shank of the indicator member to be shorter in length, leading to improved strength and stability. It may also prevent or reduce external access to the shank.

[0029] The release member is shaped to be received between the fixed and movable handles of the fire extinguisher operating mechanism. Both handles may be provided with longitudinally extending formations for example grooves or ribs to locate the release mechanism. The release member may then be provided with complementary formations.

[0030] The release member may be moulded from a plastics material such as polypropylene and it may be brightly coloured, luminescent, fluorescent etc. as the indicator member. It may be formed from different colours to reflect the type of extinguishing material held in the extinguisher, e.g. water, foam or powder. Up to 20 wt% of a coloured and/or luminous additive may be added to the material of the indicator.

[0031] The invention also extends to a fire extinguisher including a safety mechanism as discussed above.

[0032] In the described embodiment, the aperture for receiving the shank of the indicator member is provided on the movable handle of the extinguisher.

[0033] An embodiment of the invention will now be described by way of example only with reference to the accompanying drawings.

BRIEF DESCRIPTION OF THE DRAWINGS

[0034]

Figure 1 is a perspective view of a fire extinguisher incorporating a safety mechanism in accordance with the invention;

Figure 2 is a side elevation of the release member of the safety mechanism;

Figure 3 is a top view of the release member of Figure 2;

Figure 4 is a front view of the release member of Figure 2

Figure 5 is a side view of the movable handle of the fire extinguisher of Figure 1;

Figure 6 is a bottom view of the handle of Figure 5;

Figure 7 is a perspective view of the fixed handle of the fire extinguisher of Figure 1

Figure 8 is a front perspective view of the indicator member of the safety mechanism;

Figure 9 is a rear perspective view of the indicator

member of Figure 8;

Figure 10 is a side view of the indicator member of Figure 8; and

Figure 11 is a top view of the indicator member of Figure 8.

DETAILED DESCRIPTION OF AN EMBODIMENT

[0035] With reference to Figure 1, a fire extinguisher 2 comprises a head 4 having a ferrule 6 for the attachment of a hose (not shown). The head 4 comprises a fixed handle 8 and a movable handle 10 which is pivotably mounted to the fixed handle 8 about a pivot (not shown) in a known manner. As is known in the art, downward movement of the movable handle 10 presses on a actuating pin (not shown) which opens a valve to release fire suppressant, e.g. water, foam or powder through the head 4 and ferrule 6.

[0036] To avoid inadvertent operation of the extinguisher, a safety mechanism 14 is provided. The safety mechanism 14 comprises a release member 16 and an indicator member 18.

[0037] The release member 16 is moulded from a plastics material, e.g. polypropylene, and is elongate. It is received between the movable and fixed handles 8, 10. As can be seen from Figures 2 to 4, the release member 16 has a generally planar web 20 with a relatively narrow flange 22 provided around its periphery, in particular along its upper edge 24, and a relatively wide flange 26 provided along its lower edge 28. A rib 30 projects downwardly from the relatively wide flange 26.

[0038] The relatively narrow flange 22 is received within a groove 32 provided on the lower surface 34 of the movable handle 8, and the rib 30 is received in a groove 36 provided on an upwardly facing surface 37 of the fixed handle 10. The interengagement of the flange 22 in groove 32 and rib 30 in groove 36 provides lateral support for the release member 16.

[0039] The proximal end 38 of the release member 16 is provided with a circular opening 40 through which a user may insert one or more fingers. The middle section 42 of the web 20 is provided with arrow like openings 44 which indicate to the user the direction of operation of the release member 16.

[0040] The distal end 46 of the release member 16 comprises a resilient clip 48 which in use engages around a post provided in the movable handle 8.

[0041] Also provided at the distal end 46 of the release member 16 is an L-section boss 50. The boss 50 has a forwardly projecting flange 52 the distal end 54 of which is provided with an opening 56. The opening 56 is generally circular in shape, but with straight sides 58. The opening 56 receives the indicator member 18, which is described with reference to Figures 8 to 10.

[0042] The indicator member 18 is moulded from a plastics material such as polystyrene. In one embodiment, the material may be EDISTIR N1840 with 5 wt% regrind. It may be brightly coloured and may be fluores-

cent or phosphorescent.

[0043] It comprises a relatively thin, disk-shaped head 60 and a shank 62 projecting from the rear surface 64 of the head 60. Although shown as circular, the head 60 may of course have any convenient shape, for example polygonal.

[0044] The front surface 66 of the head 60 is provided with a recessed inscription 68 ("OK" in the illustrated embodiment) which will be seen by a user when the indicator member 18 is *in situ*.

[0045] The rear surface 64 of the head 60 is generally planar for engaging and covering a complementary area 70 of the movable handle 8. As can be seen from Figure 5, this area 70 bears an inscription 72, in this embodiment "USED", so that when the area 70 is exposed, the user will know that the extinguisher has been used. Of course some other wording may be used, for example "used" in other languages. That area 70 also includes an opening 71 for receiving the shank 62 of the indicator member 18.

[0046] The rear surface 64 of the head 60 also comprises a rib 74 which in use engages under a portion of the lower edge 76 of the movable handle 8 to assist in the orientation of the indicator member 18 so that the inscription 68 is the correct way up.

[0047] The shank 62 is provided with a slot 78 at its distal end 80, thereby defining two resilient legs 82. Each leg 82 is provided with a barbed tooth 84 at its distal end. The lateral surfaces 86 of each leg 82 are formed as flat surfaces for engagement with the sides 58 of the opening 56 in the distal end of the release member 16. The surfaces 86 stand proud of the surrounding surface, as can be seen most clearly from Figure 11. The upper and lower surfaces 88 of the legs 82 are generally circular in section and of a diameter smaller than the circular sections of the opening 56.

[0048] The shank 62 has a tapering proximal section 90 and a transversely waisted intermediate section 92. An opening 94 is provided through the intermediate section 92 to provide a well defined area of weakness in the shank 62. The dimensions of the waisting and opening 94 are chosen such that the shank can break in shear under an applied force of less than 100N. The maximum diameter of the proximal and intermediate sections 90, 92 is smaller than the diameter of the opening 71 provided in the area 70 of the movable handle 8 to allow the shank 62 to be received therein.

[0049] Installation and operation of the safety mechanism 14 will now be described.

[0050] As a first step, the release member 16 is inserted longitudinally into position between the handles 8, 10. The flange 22 and the rib 30 provided on the release member 16 and the grooves 32, 36 formed in the handles 8, 10 guide the release member 16 appropriately. The release member 16 is pushed into the space between the handles 8, 10 until the clip 48 engages with the valve pin. In this position, the opening 56 at the distal end of the release member 16 is aligned with the opening 71 provided in the movable handle 10. The relatively wide

flange 26 of the release member 16 generally follows the contour of and covers the upper surface 37 of the fixed handle 8.

[0051] The indicator member 18 can then be mounted. The shank 62 of the indicator member 18 is pushed through the opening 71 in the movable handle 8 and the aligned opening 56 in the release member 16. The resilience of the legs 82 of the shank 62 allow the barbed teeth 84 to deflect inwardly as the shank 62 is pressed in, and then spring back when the teeth 84 have passed through the openings 71, 56 preventing the indicator member 18 from being withdrawn through the openings. The flat lateral surfaces 86 of the legs 82 engage closely with the straight sides 58 of the opening 56. This will help prevent twisting of the shank 62 as the release member is pulled out.

[0052] Proper orientation of the head 60 is ensured by interengagement of the rib 74 of the head 60 and the lower edge 76 of the movable handle 8.

[0053] When the indicator member 18 is so inserted, the user will see from the "OK" inscription 68 that the extinguisher is ready to use. Should the user inadvertently press on the movable handle 8, operation of the extinguisher is prevented by the release member 16 which prevents the movable handle 8 moving towards the fixed handle 10. Moreover, any small force acting to pull the release member 16 rearwardly from between the handles 8, 10 will be resisted by the shank 62 of the indicator member and by the clip 48.

[0054] In the event of a fire, however, the user pulls the release member 16 from between the handles 8, 10 in the direction indicated by the arrow openings 44. The pulling action causes the weakened intermediate section 92 of the shank 62, which is within the opening 56 in the release member 16, to shear, allowing the release member 16 to be withdrawn. The release member 16 pulls the distal end 80 of the shank 62 away with it so that it does not interfere with operation of the extinguisher. The head 60 of the indicator member 18 simply falls away, no longer being retained by its shank 62. The extinguisher 2 can then be used in the normal way.

[0055] After use, it will be clear to potential other users that the extinguisher has been used since the "USED" inscription 72 is visible.

[0056] After the extinguisher 2 has been recharged, a new safety mechanism 14 may be installed. The relatively robust release member 16 is not damaged in use and so may be re-used. However, a new indicator member 18 will have to be provided. The tapering of the proximal portion 90 of the shank 62 of the indicator member 18 means that the used indicator member 18 cannot simply be pushed into the opening 71 in the handle 8, as it will simply fall out. This would be undesirable since a user would then not be able to determine with certainty whether an extinguisher had been used or not. However, as the indicator member 18 is a moulding, it is relatively inexpensive to replace.

[0057] It will be understood that the above is a descrip-

tion of just one possible embodiment of the invention and that various modifications may be made to the embodiment without departing from the scope of the invention as defined by the following claims.

Claims

1. A fire extinguisher safety mechanism comprising: an release member (16) configured for lengthwise insertion and withdrawal from between the handles (8, 10) of a fire extinguisher (2), said release member (16) having a proximal end (38) and a distal end (46), said proximal end (38) for gripping by a user; **characterised in that:** said distal end (46) has an aperture (56); and **in that** said safety mechanism further comprises:

an indicator member (18), said indicator member (18) having a head (60), a shank (62) projecting from said head (60) and having a distal end (80) with resilient retaining means, said indicator member (18) being configured to be mounted to said extinguisher (2), with its shank (62) passing through an aperture (71) in the head (4) of said extinguisher (2) and through said aperture (56) in said distal end (46) of said release member (16) so as to be retained relative to said release member (16) by said resilient retaining means and for preventing accidental withdrawal of said release member (16) from between the handles (8, 10).

2. A fire extinguisher safety mechanism as claimed in claim 1 wherein the head (60) of the indicator member (18) is relatively thin and disc like in shape.

3. A fire extinguisher safety mechanism as claimed in any preceding claim wherein the indicator member (18) is configured to be received by a complementary area (70) provided on the extinguisher head (4), more particularly an area (70) on the movable handle (8) of the extinguisher (2), said area (70) optionally carrying an inscription (72) which becomes visible once the extinguisher (2) has been used.

4. A fire extinguisher safety mechanism as claimed in any preceding claim wherein the shank (62) of the indicator member (18) is provided with one or more areas of weakness.

5. A fire extinguisher safety mechanism as claimed in claim 4 wherein the area of weakness is provided by a through hole (94).

6. A fire extinguisher safety mechanism as claimed in claim 5 wherein the hole (94) extends through a waisted area of an intermediate portion of said shank

(62).

7. A fire extinguisher safety mechanism as claimed in any preceding claim wherein a proximal portion (90) of the shank (62) tapers towards the distal end (80) of the shank (62). 5
8. A fire extinguisher safety mechanism as claimed in any preceding claim wherein the resilient retaining means provided on the distal end (80) of the shank (62) comprises barbs (84) formed on the ends of flexible legs (82) formed by a slot (78) in the distal end (80) of the shank (62). 10
9. A fire extinguisher safety mechanism as claimed in any preceding claim wherein the distal end (80) of the shank (62) has a profile which is at least in part complementary to the aperture (56) in the distal end (46) of the release member (16), for example wherein lateral surfaces of the flexible legs (82) are formed as flat surfaces to engage with flat surfaces of the aperture (56). 15 20
10. A fire extinguisher safety mechanism as claimed in any preceding claim comprising alignment means to align the indicator member (18) in an appropriate orientation on the extinguisher (2), for example wherein a rear surface (64) of the head (60) of the indicator member (18) is provided with one or more ribs (74) which engage under a lower edge (76) of the handle (8) to which the indicator member (18) is mounted. 25 30
11. A fire extinguisher safety mechanism as claimed in any preceding claim wherein the distal end (46) of the release member (16) is provided with a clip (48). 35
12. A fire extinguisher safety mechanism as claimed in any preceding claim wherein the aperture (56) for receiving the shank (62) of the indicator member (18) is provided in a boss (50) provided at the distal end (46) of the release member (16), the boss (50) being offset from the main plane of the release member (16). 40
13. A fire extinguisher safety mechanism as claimed in any preceding claim wherein the indicator member (18) and/or the release member (16) is brightly coloured, fluorescent, luminescent or phosphorescent. 45
14. A fire extinguisher comprising a safety mechanism as claimed in any preceding claim. 50

Patentansprüche

1. Sicherheitsmechanismus für einen Feuerlöscher, der Folgendes umfasst:

ein Freigabeelement (16), das für eine Einführung zwischen die Griffe (8, 10) eines Feuerlöschers (2) in Längsrichtung und ein Herausziehen von dort konfiguriert ist, wobei das Freigabeelement (16) ein proximales Ende (38) und ein distales Ende (46) aufweist, wobei das proximale Ende (38) von einem Benutzer ergriffen werden soll; **dadurch gekennzeichnet, dass:**

das distale Ende (46) eine Apertur (56) aufweist; und dadurch, dass der Sicherheitsmechanismus ferner Folgendes umfasst:

ein Anzeigeelement (18), wobei das Anzeigeelement (18) einen Kopf (60) aufweist, wobei ein Schenkel (62) von dem Kopf (60) hervorsteht und ein distales Ende (80) mit elastischen Rückhaltemitteln aufweist,

wobei das Anzeigeelement (18) dazu konfiguriert ist, an dem Löscher (2) befestigt zu sein, wobei sein Schenkel (62) eine Apertur (71) in dem Kopf (4) des Löschers (2) und die Apertur (56) in dem distalen Ende (46) des Freigabeelements (16) durchquert, um relativ zu dem Freigabeelement (16) durch die elastischen Rückhaltemittel zurückgehalten zu werden, und um ein versehentliches Herausziehen des Freigabeelements (16) zwischen den Griffen (8, 10) zu verhindern.

2. Sicherheitsmechanismus für einen Feuerlöscher nach Anspruch 1, wobei der Kopf (60) des Anzeigeelements (18) relativ dünn ist und eine scheibenförmige Form aufweist.

3. Sicherheitsmechanismus für einen Feuerlöscher nach einem der vorhergehenden Ansprüche, wobei das Anzeigeelement (18) dazu konfiguriert ist, in einem komplementären Bereich (70) aufgenommen zu werden, der an dem Löscherkopf (4) bereitgestellt ist, insbesondere einem Bereich (70) an dem beweglichen Griff (8) des Löschers (2), wobei der Bereich (70) gegebenenfalls eine Aufschrift (72) trägt, die sichtbar wird, sobald der Löscher (2) benutzt worden ist.

4. Sicherheitsmechanismus für einen Feuerlöscher nach einem der vorhergehenden Ansprüche, wobei der Schenkel (62) des Anzeigeelements (18) mit einer oder mehreren Sollbruchstellen versehen ist.

5. Sicherheitsmechanismus für einen Feuerlöscher nach Anspruch 4, wobei die Sollbruchstelle durch eine Durchgangsöffnung (94) bereitgestellt ist.

6. Sicherheitsmechanismus für einen Feuerlöscher nach Anspruch 5, wobei die Öffnung (94) sich durch einen taillierten Bereich eines Zwischenabschnitts des Schenkels (62) erstreckt.

7. Sicherheitsmechanismus für einen Feuerlöscher nach einem der vorhergehenden Ansprüche, wobei ein proximaler Abschnitt (90) des Schenkels (62) sich in Richtung des distalen Endes (80) des Schenkels (62) verjüngt.
8. Sicherheitsmechanismus für einen Feuerlöscher nach einem der vorhergehenden Ansprüche, wobei die elastischen Rückhaltemittel, die an dem distalen Ende (80) des Schenkels (62) bereitgestellt sind, Haken (84) umfassen, die an den Enden von flexiblen Beinen (82) ausgebildet sind, die durch einen Schlitz (78) in dem distalen Ende (80) des Schenkels (62) ausgebildet sind.
9. Sicherheitsmechanismus für einen Feuerlöscher nach einem der vorhergehenden Ansprüche, wobei das distale Ende (80) des Schenkels (62) eine Profil aufweist, welches mindestens teilweise komplementär zu der Apertur (56) in dem distalen Ende (46) des Freigabeelements (16) ist, wobei zum Beispiel seitliche Flächen der flexiblen Beine (82) als flache Flächen ausgebildet sind, die die flachen Flächen der Apertur (56) in Eingriff nehmen sollen.
10. Sicherheitsmechanismus für einen Feuerlöscher nach einem der vorhergehenden Ansprüche, umfassend Ausrichtungsmittel zum Ausrichten des Anzeigeelements (18) in einer geeigneten Orientierung an dem Löscher (2), wobei zum Beispiel eine hintere Fläche (64) des Kopfs (60) des Anzeigeelements (18) mit einer oder mehreren Rippen (74) versehen ist, welche unter einer unteren Kante (76) des Griffs (8) in Eingriff stehen, an welchem das Anzeigeelement (18) befestigt ist.
11. Sicherheitsmechanismus für einen Feuerlöscher nach einem der vorhergehenden Ansprüche, wobei das distale Ende (46) des Freigabeelements (16) mit einer Klammer (48) bereitgestellt ist.
12. Sicherheitsmechanismus für einen Feuerlöscher nach einem der vorhergehenden Ansprüche, wobei die Apertur (56) zum Aufnehmen des Schenkels (62) des Anzeigeelements (18) in einer Wulst (50) bereitgestellt ist, die an dem distalen Ende (46) des Freigabeelements (16) bereitgestellt ist, wobei die Wulst (50) gegenüber der Hauptebene des Freigabeelements (16) versetzt ist.
13. Sicherheitsmechanismus für einen Feuerlöscher nach einem der vorhergehenden Ansprüche, wobei das Anzeigeelement (18) und/oder das Freigabeelement (16) hell gefärbt, fluoreszierend, lumineszierend oder phosphoreszierend sind.
14. Feuerlöscher, der einen Sicherheitsmechanismus nach einem der vorhergehenden Ansprüche um-

fasst.

Revendications

- 5
1. Mécanisme de sécurité d'extincteur d'incendie comprenant :
- 10 un élément de libération (16) configuré pour une insertion et un retrait dans le sens de la longueur entre les poignées (8, 10) d'un extincteur d'incendie (2), ledit élément de libération (16) ayant une extrémité proximale (38) et une extrémité distale (46), ladite extrémité proximale (38) étant destinée à une préhension par un utilisateur ; **caractérisé en ce que** :
- 15 ladite extrémité distale (46) a une ouverture (56) ; et **en ce que** ledit mécanisme de sécurité comprend en outre :
- 20 un élément indicateur (18), ledit élément indicateur (18) ayant une tête (60), un manche (62) faisant saillie à partir de ladite tête (60) et ayant une extrémité distale (80) avec des moyens de retenue résilients,
- 25 ledit élément indicateur (18) étant configuré pour être monté sur ledit extincteur (2), avec son manche (62) passant à travers une ouverture (71) dans la tête (4) dudit extincteur (2) et à travers ladite ouverture (56) dans ladite extrémité distale (46) dudit élément de libération (16) de façon à être retenu par rapport audit élément de libération (16) par lesdits moyens de retenue résilients et pour empêcher un retrait accidentel dudit élément de libération (16) entre les poignées (8, 10).
- 30
2. Mécanisme de sécurité d'extincteur d'incendie selon la revendication 1, dans lequel la tête (60) de l'élément indicateur (18) est relativement mince et a une forme de type disque.
- 35
3. Mécanisme de sécurité d'extincteur d'incendie selon une quelconque revendication précédente, dans lequel l'élément indicateur (18) est configuré pour être reçu par une zone complémentaire (70) prévue sur la tête d'extincteur (4), plus particulièrement une zone (70) sur la poignée mobile (8) de l'extincteur (2), ladite zone (70) portant facultativement une inscription (72) qui devient visible une fois que l'extincteur (2) a été utilisé.
- 40
4. Mécanisme de sécurité d'extincteur d'incendie selon une quelconque revendication précédente, dans lequel le manche (62) de l'élément indicateur (18) est doté d'une ou plusieurs zones de faiblesse.
- 45
5. Mécanisme de sécurité d'extincteur d'incendie selon la revendication 4, dans lequel la zone de faiblesse est fournie par un trou débouchant (94).
- 50
- 55

6. Mécanisme de sécurité d'extincteur d'incendie selon la revendication 5, dans lequel le trou (94) s'étend à travers une zone cintrée d'une portion intermédiaire dudit manche (62). 5
7. Mécanisme de sécurité d'extincteur d'incendie selon une quelconque revendication précédente, dans lequel une portion proximale (90) du manche (62) rétrécit progressivement vers l'extrémité distale (80) du manche (62). 10
8. Mécanisme de sécurité d'extincteur d'incendie selon une quelconque revendication précédente, dans lequel les moyens de retenue résilients prévus sur l'extrémité distale (80) du manche (62) comprennent des arêtes (84) formées sur les extrémités de pattes flexibles (82) formées par une encoche (78) dans l'extrémité distale (80) du manche (62). 15
9. Mécanisme de sécurité d'extincteur d'incendie selon une quelconque revendication précédente, dans lequel l'extrémité distale (80) du manche (62) a un profil qui est au moins en partie complémentaire de l'ouverture (56) dans l'extrémité distale (46) de l'élément de libération (16), par exemple dans lequel des surfaces latérales des pattes flexibles (82) sont formées en tant que surfaces plates pour se mettre en prise avec des surfaces plates de l'ouverture (56). 20
25
10. Mécanisme de sécurité d'extincteur d'incendie selon une quelconque revendication précédente, comprenant des moyens d'alignement pour aligner l'élément indicateur (18) dans une orientation appropriée sur l'extincteur (2), par exemple dans lequel une surface arrière (64) de la tête (60) de l'élément indicateur (18) est dotée d'une ou plusieurs nervures (74) qui se mettent en prise sous un bord inférieur (76) de la poignée (8) sur laquelle l'élément indicateur (18) est monté. 30
35
40
11. Mécanisme de sécurité d'extincteur d'incendie selon une quelconque revendication précédente, dans lequel l'extrémité distale (46) de l'élément de libération (16) est dotée d'une attache (48). 45
12. Mécanisme de sécurité d'extincteur d'incendie selon une quelconque revendication précédente, dans lequel l'ouverture (56) pour recevoir le manche (62) de l'élément indicateur (18) est prévue dans un bossage (50) prévu au niveau de l'extrémité distale (46) de l'élément de libération (16), le bossage (50) étant décalé par rapport au plan principal de l'élément de libération (16). 50
13. Mécanisme de sécurité d'extincteur d'incendie selon une quelconque revendication précédente, dans lequel l'élément indicateur (18) et/ou l'élément de libération (16) ont une couleur éclatante, sont fluores- 55
- cents, luminescents ou phosphorescents.
14. Extincteur d'incendie comprenant un mécanisme de sécurité selon une quelconque revendication précédente.

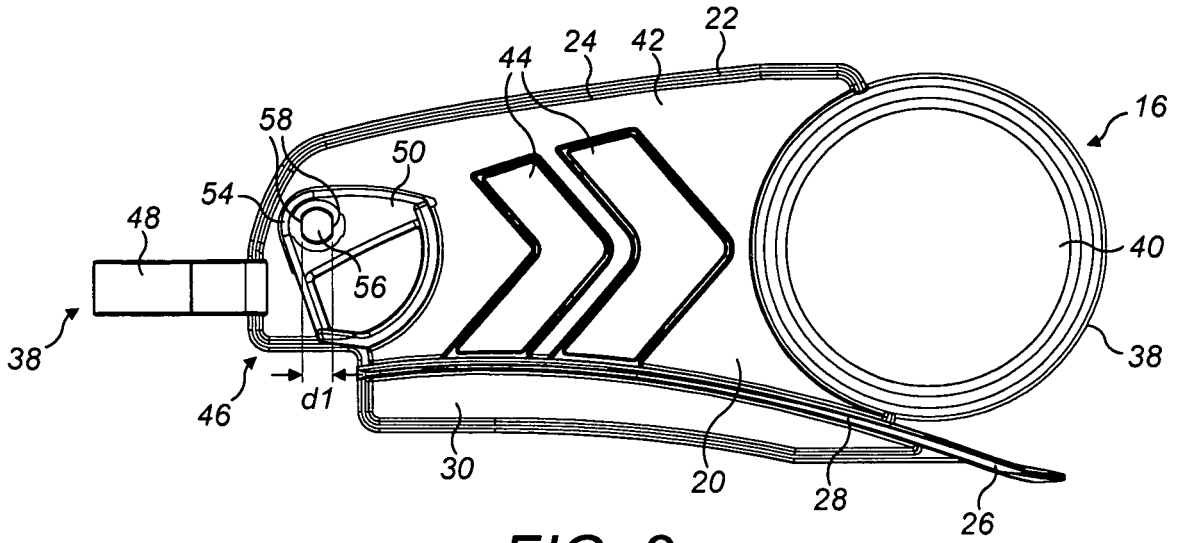

FIG. 2

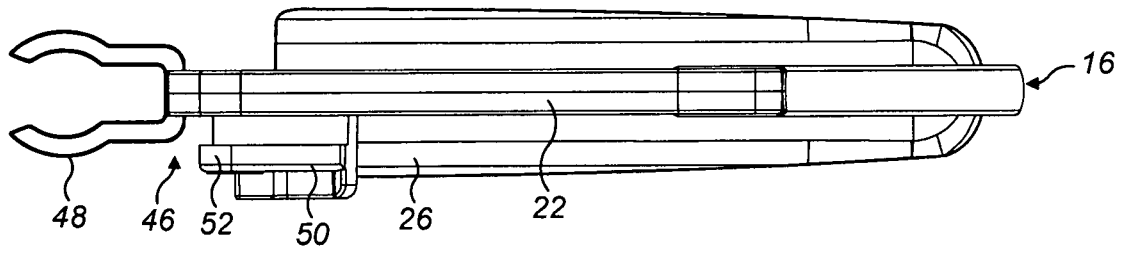

FIG. 3

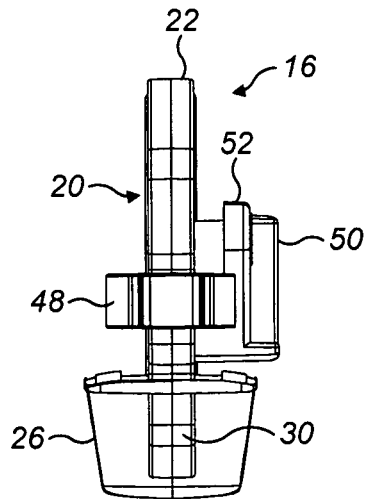
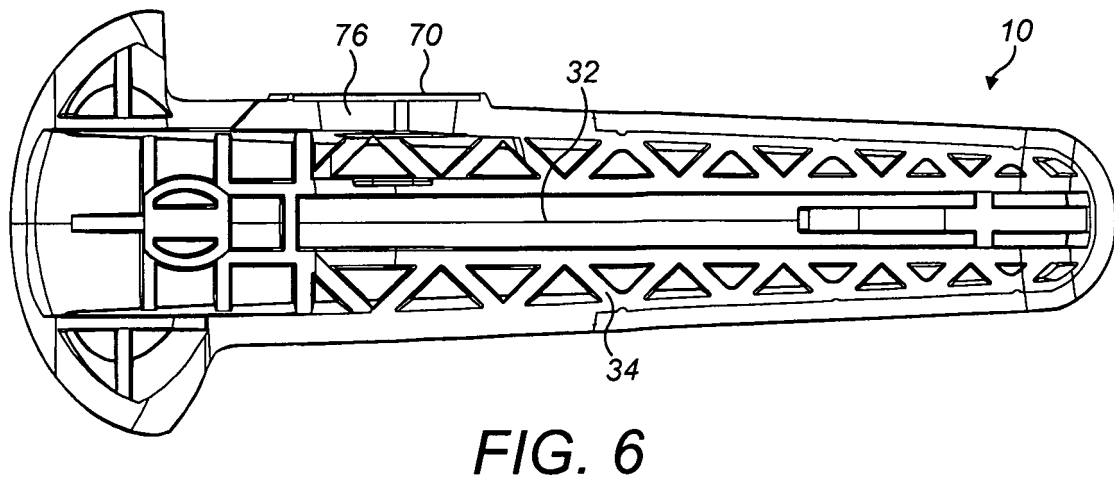
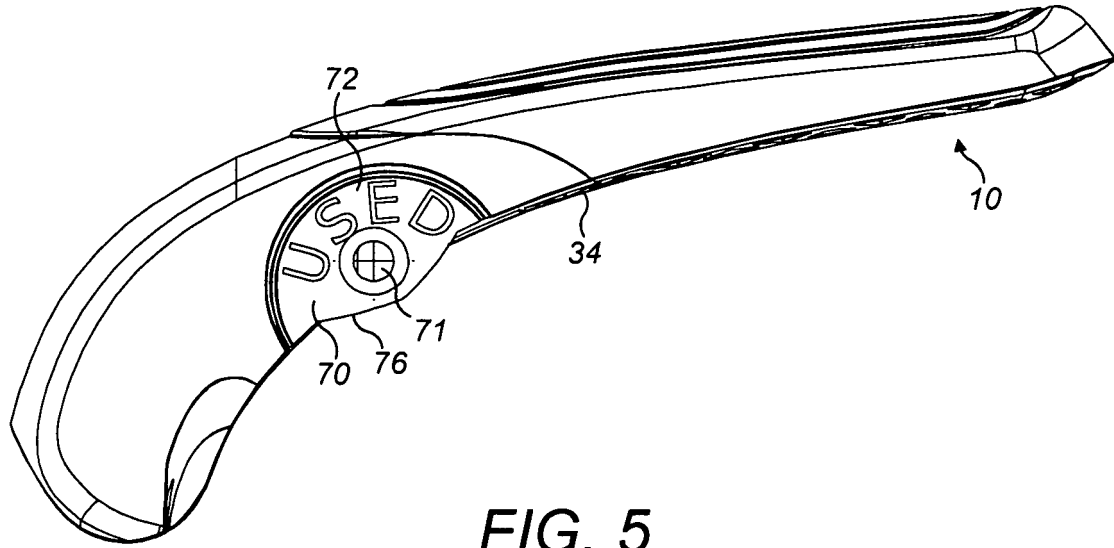

FIG. 4



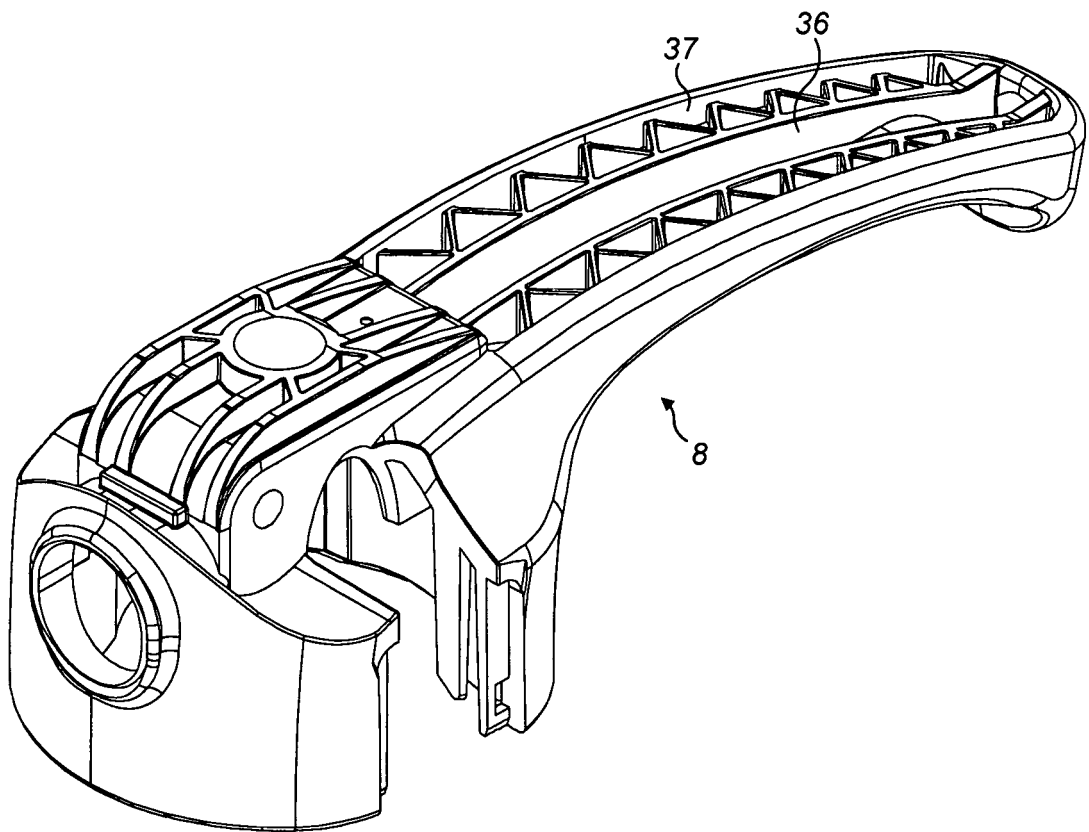

FIG. 7

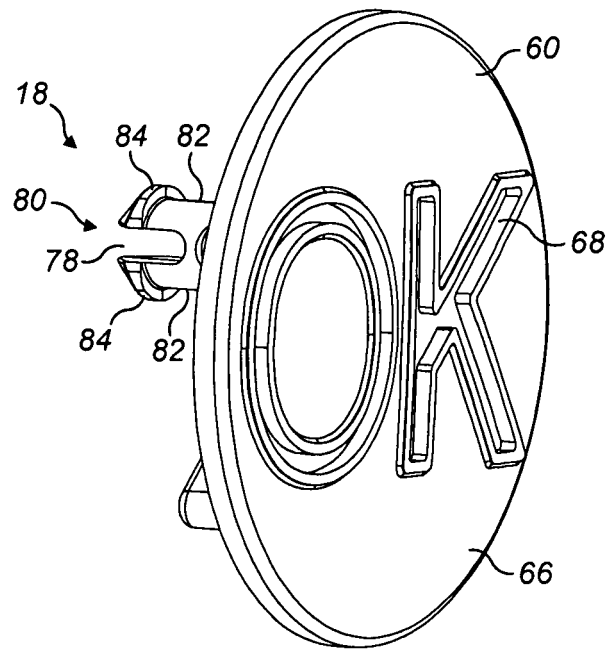

FIG. 8

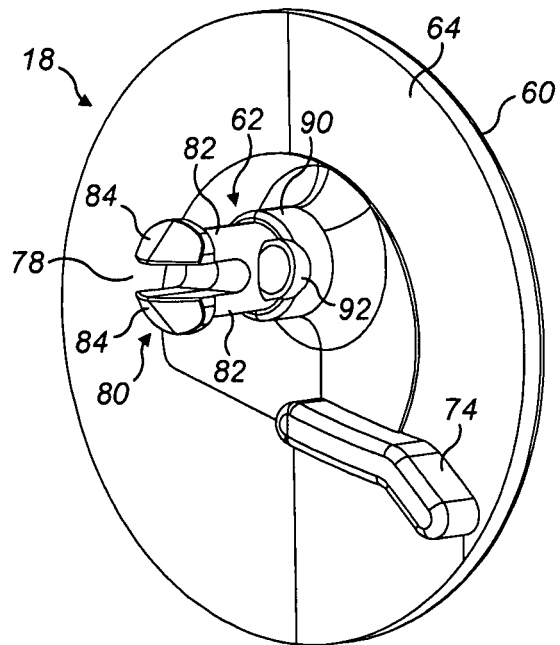

FIG. 9

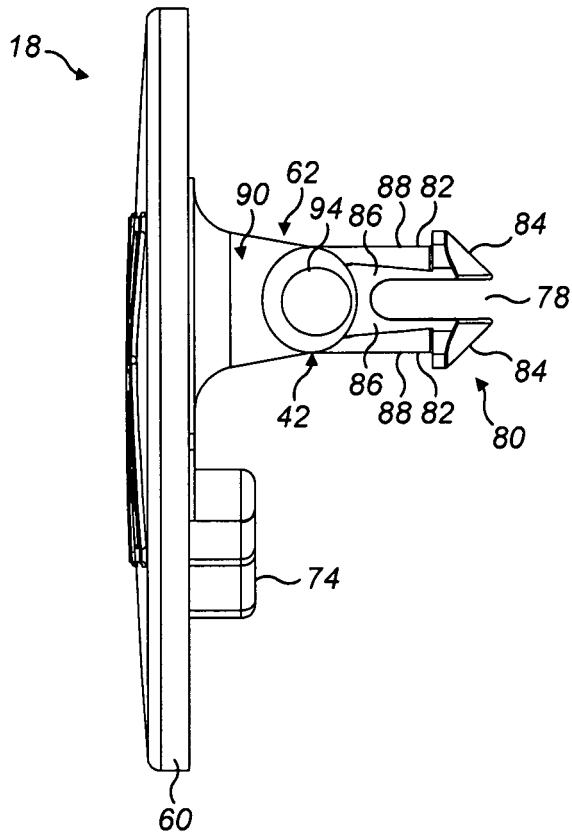

FIG. 10

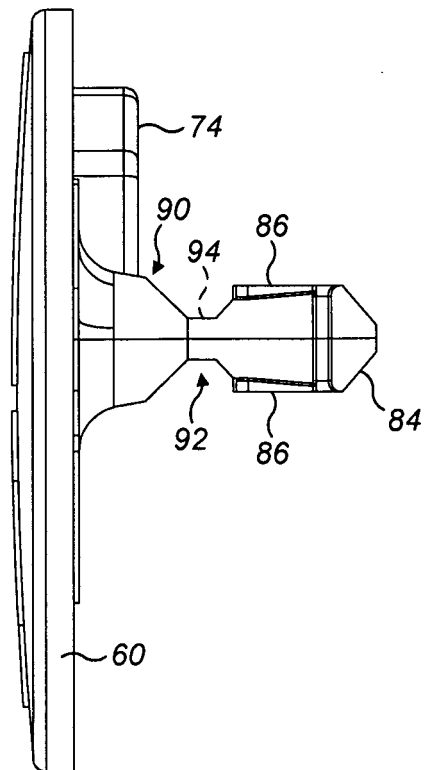

FIG. 11

REFERENCES CITED IN THE DESCRIPTION

This list of references cited by the applicant is for the reader's convenience only. It does not form part of the European patent document. Even though great care has been taken in compiling the references, errors or omissions cannot be excluded and the EPO disclaims all liability in this regard.

Patent documents cited in the description

- US 3844356 A [0002]
- US 3666016 A [0003]
- GB 2322298 A [0007]
- JP S5059894 U [0007]