

(19) World Intellectual Property Organization
International Bureau



(43) International Publication Date
24 August 2006 (24.08.2006)

PCT

(10) International Publication Number
WO 2006/088785 A1

- (51) International Patent Classification:
A61B 5/15 (2006.01) A61M 1/36 (2006.01)
- (21) International Application Number:
PCT/US2006/005005
- (22) International Filing Date:
13 February 2006 (13.02.2006)
- (25) Filing Language: English
- (26) Publication Language: English
- (30) Priority Data:

60/652,660	14 February 2005 (14.02.2005)	US
60/658,001	2 March 2005 (02.03.2005)	US
60/673,551	21 April 2005 (21.04.2005)	US
60/724,199	6 October 2005 (06.10.2005)	US
11/316,205	21 December 2005 (21.12.2005)	US
11/316,681	21 December 2005 (21.12.2005)	US

1547 Petersen Avenue, San Jose, California 95129 (US).
WECHSLER, Mark [US/US]; 181 42nd Avenue, San Mateo, California 94403 (US). **RULE, Peter** [US/US]; 24183 Hillview Road, Los Altos Hills, California 94024 (US). **KEENAN, Richard** [US/US]; 2342 Sixth Street, Livermore, California 94550 (US).

(74) Agent: **ALTMAN, Daniel, E.**; KNOBBE, MARTENS, OLSON & BEAR, LLP, 2040 Main Street, Fourteenth Floor, Irvine, California 92614 (US).

(81) Designated States (unless otherwise indicated, for every kind of national protection available): AE, AG, AL, AM, AT, AU, AZ, BA, BB, BG, BR, BW, BY, BZ, CA, CH, CN, CO, CR, CU, CZ, DE, DK, DM, DZ, EC, EE, EG, ES, FI, GB, GD, GE, GH, GM, HR, HU, ID, IL, IN, IS, JP, KE, KG, KM, KN, KP, KR, KZ, LC, LK, LR, LS, LT, LU, LV, LY, MA, MD, MG, MK, MN, MW, MX, MZ, NA, NG, NI, NO, NZ, OM, PG, PH, PL, PT, RO, RU, SC, SD, SE, SG, SK, SL, SM, SY, TJ, TM, TN, TR, TT, TZ, UA, UG, US, UZ, VC, VN, YU, ZA, ZM, ZW.

(84) Designated States (unless otherwise indicated, for every kind of regional protection available): ARIPO (BW, GH, GM, KE, LS, MW, MZ, NA, SD, SL, SZ, TZ, UG, ZM, ZW), Eurasian (AM, AZ, BY, KG, KZ, MD, RU, TJ, TM), European (AT, BE, BG, CH, CY, CZ, DE, DK, EE, ES, FI,

[Continued on next page]

(54) Title: ANALYTE DETECTION SYSTEM WITH DISTRIBUTED SENSING

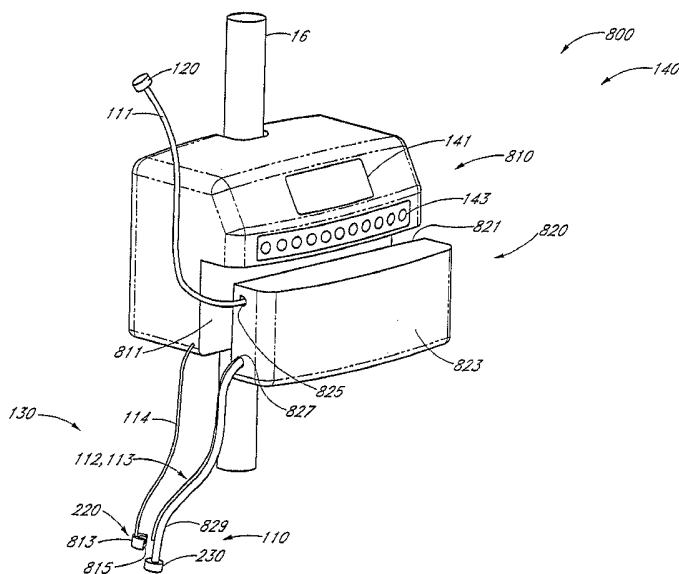

(57) Abstract: In certain embodiments, a sampling assembly is for use with a main analyzer. The main analyzer is configured to sense an analyte in a body fluid obtained from a patient through a first fluid passageway extending from the main analyzer. The sampling assembly includes an instrument portion separate from the main analyzer and including at least one sensor. The instrument portion is removably engaged with the first fluid passageway. The at least one sensor is in sensing engagement with the first fluid passageway such that the at least one sensor can sense a property of a fluid within the first fluid passageway.

WO 2006/088785 A1



FR, GB, GR, HU, IE, IS, IT, LT, LU, LV, MC, NL, PL, PT,
RO, SE, SI, SK, TR), OAPI (BF, BJ, CF, CG, CI, CM, GA,
GN, GQ, GW, ML, MR, NE, SN, TD, TG).

— *before the expiration of the time limit for amending the
claims and to be republished in the event of receipt of
amendments*

Published:

— *with international search report*

*For two-letter codes and other abbreviations, refer to the "Guid-
ance Notes on Codes and Abbreviations" appearing at the begin-
ning of each regular issue of the PCT Gazette.*

ANALYTE DETECTION SYSTEM WITH DISTRIBUTED SENSING

Background

Field

[0001] Certain embodiments disclosed herein relate to methods and apparatus for determining the concentration of an analyte in a sample, such as an analyte in a sample of bodily fluid, as well as methods and apparatus which can be used to support the making of such determinations.

Description of the Related Art

[0002] It is a common practice to measure the levels of certain analytes, such as glucose, in a bodily fluid, such as blood. Often this is done in a hospital or clinical setting when there is a risk that the levels of certain analytes may move outside a desired range, which in turn can jeopardize the health of a patient. Certain currently known systems for analyte monitoring in a hospital or clinical setting suffer from various drawbacks.

Summary

[0003] In certain embodiments, a sampling assembly is configured for use with a main analyzer. The main analyzer is configured to sense an analyte in a body fluid obtained from a patient through a first fluid passageway extending from the main analyzer. The sampling assembly comprises an instrument portion separate from the main analyzer and comprising at least one sensor. The instrument portion is removably engaged with the first fluid passageway. The at least one sensor is in sensing engagement with the first fluid passageway such that the at least one sensor can sense a property of a fluid within the first fluid passageway. In certain other embodiments, the at least one sensor is configured to detect the arrival of the body fluid in the first fluid passageway.

[0004] In certain embodiments, a sampling assembly is configured for use with a main analyzer. The main analyzer is configured to sense an analyte in a body fluid obtained from a patient through a first fluid passageway. The passageway has a patient end spaced from the main analyzer and an interface region where the first fluid passageway meets the main analyzer. The sampling assembly comprises an instrument portion comprising at least one sensor. The instrument portion is removably engaged with the first fluid passageway between the patient end and the interface region. The at least one sensor is in sensing engagement with the first fluid passageway such that the at least one sensor can sense a property of a fluid contained in the first fluid passageway. In certain other

embodiments, the at least one sensor is configured to detect the arrival of the body fluid in the first fluid passageway.

[0005] In certain embodiments, a body fluid analysis system comprises a main analyzer configured to measure an analyte in a sample of body fluid obtained from a patient. The body fluid analysis system further comprises a sampling assembly in communication with the main analyzer. The sampling assembly comprises a first fluid passageway extending from the main analyzer and having a patient end spaced from the main analyzer. The sampling assembly further comprises an instrument portion removably engaged with the first fluid passageway and located on the first fluid passageway spaced from the main analyzer. The instrument portion has at least one sensor in sensing engagement with the first fluid passageway. In certain other embodiments, at least one of the at least one sensor is configured to detect the arrival of the body fluid in the first fluid passageway.

[0006] In certain embodiments, a method of handles body fluid within a first fluid passageway which extends from and is in fluid communication with a main analyzer. The method comprises removably engaging the first fluid passageway with a sensing module separate from the main analyzer. The method further comprises, with at least one sensor of the sensing module, sensing a property of a fluid within the first fluid passageway. In certain other embodiments, the sensing comprises sensing the arrival of the fluid in the first fluid passageway.

[0007] Certain objects and advantages of the invention(s) are described herein. Of course, it is to be understood that not necessarily all such objects or advantages may be achieved in accordance with any particular embodiment. Thus, for example, those skilled in the art will recognize that the invention(s) may be embodied or carried out in a manner that achieves or optimizes one advantage or group of advantages as taught herein without necessarily achieving other objects or advantages as may be taught or suggested herein.

[0008] Certain embodiments are summarized above. However, despite the foregoing discussion of certain embodiments, only the appended claims (and not the present summary) are intended to define the invention(s). The summarized embodiments, and other embodiments, will become readily apparent to those skilled in the art from the following detailed description of the preferred embodiments having reference to the attached figures, the invention(s) not being limited to any particular embodiment(s) disclosed.

[0009] In certain embodiments, an apparatus for analyzing the composition of bodily fluid comprises a first fluid passageway having a patient end which is configured to provide fluid communication with a bodily fluid within a patient. The apparatus further comprises at least one pump coupled to the first fluid passageway. The at least one pump has an infusion mode in which the pump is operable to deliver infusion fluid to the patient through the patient end, and a sample draw mode in which the pump is operable to draw a sample of the bodily fluid from the patient through the patient end. The apparatus further comprises an analyte detection system accessible via the first fluid passageway such that the analyte detection system can receive at least one component of the drawn sample of bodily fluid and determine a concentration of at least one analyte. The analyte detection system is spaced from the patient end of the first fluid passageway. The apparatus further comprises a fluid sensor located at or near the patient end of the first fluid passageway and spaced from the analyte detection system. The fluid sensor is configured to sense a property of a fluid within the first fluid passageway. In certain other embodiments, the fluid sensor is configured to detect the arrival of the drawn sample of bodily fluid in the first fluid passageway.

[0010] In certain embodiments, a fluid-handling method comprises providing a first fluid passageway having a patient end and a spectroscopic analyte detection system accessible via the first fluid passageway. The method further comprises infusing an infusion fluid through the patient end. The method further comprises drawing a body fluid through the patient end. The method further comprises sensing a property of a fluid within the first fluid passageway at a sensing location at or near the patient end and spaced from the analyte detection system. The method further comprise determining the concentration of at least one analyte in the fluid within the first fluid passageway using the analyte detection system. In certain embodiments, the sensing comprises detecting the arrival of the fluid within the first fluid passageway.

[0011] In certain embodiments, a method for analyzing the composition of a body fluid comprises obtaining a body fluid sample from a patient end of a first fluid passageway. The method further comprises passing the sample through the first fluid passageway towards an analyte detection system. The method further comprises detecting a property of the sample at a location along the first fluid passageway. The method further comprises separating the sample into a first portion and a second portion, passing the first portion to the analyte detection system, and returning the second portion through the patient

end of the first fluid passageway. In certain other embodiments, the first portion travels a first distance to the analyte detection system, the second portion travels a second distance to the patient end, and the second distance is smaller than the first distance.

[0012] In certain embodiments, a system for obtaining a body fluid sample comprises a first fluid passageway having a patient end which is configured to provide fluid communication with a body fluid of a patient. The system further comprises a sensor located at a predetermined location along the first fluid passageway. The sensor is configured to detect a property of fluid within the first fluid passageway. The system further comprises an analyte detection system in fluid communication with the first fluid passageway. At least a first portion of the fluid within the first fluid passageway at the predetermined location travels a first distance to the analyte detection system and at least a second portion of the fluid within the first fluid passageway at the predetermined location travels a second distance to the patient. In certain other embodiments, the second distance is smaller than the first distance.

[0013] Certain objects and advantages of the invention(s) are described herein. Of course, it is to be understood that not necessarily all such objects or advantages may be achieved in accordance with any particular embodiment. Thus, for example, those skilled in the art will recognize that the invention(s) may be embodied or carried out in a manner that achieves or optimizes one advantage or group of advantages as taught herein without necessarily achieving other objects or advantages as may be taught or suggested herein.

Certain embodiments are summarized above. However, despite the foregoing discussion of certain embodiments, only the appended claims (and not the present summary) are intended to define the invention(s). The summarized embodiments, and other embodiments, will become readily apparent to those skilled in the art from the following detailed description of the preferred embodiments having reference to the attached figures, the invention(s) not being limited to any particular embodiment(s) disclosed.

Brief Description of the Drawings

[0014] FIGURE 1 is a schematic of a fluid handling system in accordance with one embodiment;

[0015] FIGURE 1A is a schematic of a fluid handling system, wherein a fluid handling and analysis apparatus of the fluid handling system is shown in a cutaway view;

[0016] FIGURE 1B is a cross-sectional view of a bundle of the fluid handling system of FIGURE 1A taken along the line 1B-1B;

[0017] FIGURE 2 is a schematic of an embodiment of a sampling apparatus;

[0018] FIGURE 3 is a schematic showing details of an embodiment of a sampling apparatus;

[0019] FIGURE 4 is a schematic of an embodiment of a sampling unit;

[0020] FIGURE 5 is a schematic of an embodiment of a sampling apparatus;

[0021] FIGURE 6A is a schematic of an embodiment of gas injector manifold;

[0022] FIGURE 6B is a schematic of an embodiment of gas injector manifold;

[0023] FIGURES 7A-7J are schematics illustrating methods of using the infusion and blood analysis system, where FIGURE 7A shows one embodiment of a method of infusing a patient, and FIGURES 7B-7J illustrate steps in a method of sampling from a patient, where FIGURE 7B shows fluid being cleared from a portion of the first and second passageways; FIGURE 7C shows a sample being drawn into the first passageway; FIGURE 7D shows a sample being drawn into second passageway; FIGURE 7E shows air being injected into the sample; FIGURE 7F shows bubbles being cleared from the second passageway; FIGURES 7H and 7I show the sample being pushed part way into the second passageway followed by fluid and more bubbles; and FIGURE 7J shows the sample being pushed to analyzer;

[0024] FIGURE 8 is a perspective front view of an embodiment of a sampling apparatus;

[0025] FIGURE 9 is a schematic front view of one embodiment of a sampling apparatus cassette;

[0026] FIGURE 10 is a schematic front view of one embodiment of a sampling apparatus instrument;

[0027] FIGURE 11 is an illustration of one embodiment of an arterial patient connection;

[0028] FIGURE 12 is an illustration of one embodiment of a venous patient connection;

[0029] FIGURES 13A, 13B, and 13C are various views of one embodiment of a pinch valve, where FIGURE 13A is a front view, FIGURE 13B is a sectional view, and FIGURE 13C is a sectional view showing one valve in a closed position;

[0030] FIGURES 14A and 14B are various views of one embodiment of a pinch valve, where FIGURE 14A is a front view and FIGURE 14B is a sectional view showing one valve in a closed position;

[0031] FIGURE 15 is a side view of one embodiment of a separator;

[0032] FIGURE 16 is an exploded perspective view of the separator of FIGURE 15;

[0033] FIGURE 17 is one embodiment of a fluid analysis apparatus;

[0034] FIGURE 18 is a top view of a cuvette for use in the apparatus of FIGURE 17;

[0035] FIGURE 19 is a side view of the cuvette of FIGURE 18;

[0036] FIGURE 20 is an exploded perspective view of the cuvette of FIGURE 18;

[0037] FIGURE 21 is a schematic of an embodiment of a sample preparation unit;

[0038] FIGURE 22A is a perspective view of another embodiment of a fluid handling and analysis apparatus having a main instrument and removable cassette;

[0039] FIGURE 22B is a partial cutaway, side elevational view of the fluid handling and analysis apparatus with the cassette spaced from the main instrument;

[0040] FIGURE 22C is a cross-sectional view of the fluid handling and analysis apparatus of FIGURE 22A wherein the cassette is installed onto the main instrument;

[0041] FIGURE 23A is a cross-sectional view of the cassette of the fluid handling and analysis apparatus of FIGURE 22A taken along the line 23A-23A;

[0042] FIGURE 23B is a cross-sectional view of the cassette of FIGURE 23A taken along the line 23B-23B of FIGURE 23A;

[0043] FIGURE 23C is a cross-sectional view of the fluid handling and analysis apparatus having a fluid handling network, wherein a rotor of the cassette is in a generally vertical orientation;

[0044] FIGURE 23D is a cross-sectional view of the fluid handling and analysis apparatus, wherein the rotor of the cassette is in a generally horizontal orientation;

[0045] FIGURE 23E is a front elevational view of the main instrument of the fluid handling and analysis apparatus of FIGURE 23C;

[0046] FIGURE 24A is a cross-sectional view of the fluid handling and analysis apparatus having a fluid handling network in accordance with another embodiment;

[0047] FIGURE 24B is a front elevational view of the main instrument of the fluid handling and analysis apparatus of FIGURE 24A;

[0048] FIGURE 25A is a front elevational view of a rotor having a sample element for holding sample fluid;

[0049] FIGURE 25B is a rear elevational view of the rotor of FIGURE 25A;

[0050] FIGURE 25C is a front elevational view of the rotor of FIGURE 25A with the sample element filled with a sample fluid;

[0051] FIGURE 25D is a front elevational view of the rotor of FIGURE 25C after the sample fluid has been separated;

[0052] FIGURE 25E is a cross-sectional view of the rotor taken along the line 25E-25E of FIGURE 25A;

[0053] FIGURE 25F is an enlarged sectional view of the rotor of FIGURE 25E;

[0054] FIGURE 26A is an exploded perspective view of a sample element for use with a rotor of a fluid handling and analysis apparatus;

[0055] FIGURE 26B is a perspective view of an assembled sample element;

[0056] FIGURE 27A is a front elevational view of a fluid interface for use with a cassette;

[0057] FIGURE 27B is a top elevational view of the fluid interface of FIGURE 27A;

[0058] FIGURE 27C is an enlarged side view of a fluid interface engaging a rotor;

[0059] FIGURE 28 is a cross-sectional view of the main instrument of the fluid handling and analysis apparatus of FIGURE 22A taken along the line 28-28;

[0060] FIGURE 29 is a graph illustrating the absorption spectra of various components that may be present in a blood sample;

[0061] FIGURE 30 is a graph illustrating the change in the absorption spectra of blood having the indicated additional components of FIGURE 29 relative to a Sample Population blood and glucose concentration, where the contribution due to water has been numerically subtracted from the spectra;

[0062] FIGURE 31 is an embodiment of an analysis method for determining the concentration of an analyte in the presence of possible interferents;

[0063] FIGURE 32 is one embodiment of a method for identifying interferents in a sample for use with the embodiment of FIGURE 31;

[0064] FIGURE 33A is a graph illustrating one embodiment of the method of FIGURE 32, and FIGURE 33B is a graph further illustrating the method of FIGURE 32;

[0065] FIGURE 34 is a one embodiment of a method for generating a model for identifying possible interferents in a sample for use with an embodiment of FIGURE 31;

[0066] FIGURE 35 is a schematic of one embodiment of a method for generating randomly-scaled interferent spectra;

[0067] FIGURE 36 is one embodiment of a distribution of interferent concentrations for use with the embodiment of FIGURE 35;

[0068] FIGURE 37 is a schematic of one embodiment of a method for generating combination interferent spectra;

[0069] FIGURE 38 is a schematic of one embodiment of a method for generating an interferent-enhanced spectral database;

[0070] FIGURE 39 is a graph illustrating the effect of interferents on the error of glucose estimation;

[0071] FIGURES 40A, 40B, 40C, and 40D each have a graph showing a comparison of the absorption spectrum of glucose with different interferents taken using two different techniques: a Fourier Transform Infrared (FTIR) spectrometer having an interpolated resolution of 1 cm^{-1} (solid lines with triangles); and by 25 finite-bandwidth IR filters having a Gaussian profile and full-width half-maximum (FWHM) bandwidth of 28 cm^{-1} corresponding to a bandwidth that varies from 140 nm at $7.08 \text{ }\mu\text{m}$, up to 279 nm at $10 \text{ }\mu\text{m}$ (dashed lines with circles). The Figures show a comparison of glucose with mannitol (FIGURE 40A), dextran (FIGURE 40B), n-acetyl L cysteine (FIGURE 40C), and procainamide (FIGURE 40D), at a concentration level of 1 mg/dL and path length of $1 \text{ }\mu\text{m}$;

[0072] FIGURE 41 shows a graph of the blood plasma spectra for 6 blood sample taken from three donors in arbitrary units for a wavelength range from $7 \text{ }\mu\text{m}$ to $10 \text{ }\mu\text{m}$, where the symbols on the curves indicate the central wavelengths of the 25 filters;

[0073] FIGURES 42A, 42B, 42C, and 42D contain spectra of the Sample Population of 6 samples having random amounts of mannitol (FIGURE 42A), dextran (FIGURE 42B), n-acetyl L cysteine (FIGURE 42C), and procainamide (FIGURE 42D), at a concentration levels of 1 mg/dL and path lengths of $1 \text{ }\mu\text{m}$;

[0074] FIGURES 43A-43D are graphs comparing calibration vectors obtained by training in the presence of an interferent, to the calibration vector obtained by training on

clean plasma spectra for mannitol (FIGURE 43A), dextran (FIGURE 43B), n-acetyl L cysteine (FIGURE 43C), and procainamide (FIGURE 43D) for water-free spectra;

[0075] FIGURE 44 is a schematic illustration of another embodiment of the analyte detection system;

[0076] FIGURE 45 is a plan view of one embodiment of a filter wheel suitable for use in the analyte detection system depicted in FIGURE 44;

[0077] FIGURE 46 is a partial sectional view of another embodiment of an analyte detection system;

[0078] FIGURE 47 is a detailed sectional view of a sample detector of the analyte detection system illustrated in FIGURE 46; and

[0079] FIGURE 48 is a detailed sectional view of a reference detector of the analyte detection system illustrated in FIGURE 46.

[0080] Reference symbols are used in the Figures to indicate certain components, aspects or features shown therein, with reference symbols common to more than one Figure indicating like components, aspects or features shown therein.

Detailed Description of the Preferred Embodiments

[0081] Although certain preferred embodiments and examples are disclosed below, it will be understood by those skilled in the art that the inventive subject matter extends beyond the specifically disclosed embodiments to other alternative embodiments and/or uses of the invention, and to obvious modifications and equivalents thereof. Thus it is intended that the scope of the inventions herein disclosed should not be limited by the particular disclosed embodiments described below. Thus, for example, in any method or process disclosed herein, the acts or operations making up the method/process may be performed in any suitable sequence, and are not necessarily limited to any particular disclosed sequence. For purposes of contrasting various embodiments with the prior art, certain aspects and advantages of these embodiments are described where appropriate herein. Of course, it is to be understood that not necessarily all such aspects or advantages may be achieved in accordance with any particular embodiment. Thus, for example, it should be recognized that the various embodiments may be carried out in a manner that achieves or optimizes one advantage or group of advantages as taught herein without necessarily achieving other aspects or advantages as may be taught or suggested herein. While the systems and methods discussed herein can be used for invasive techniques, the

systems and methods can also be used for non-invasive techniques or other suitable techniques, and can be used in hospitals, healthcare facilities, ICUs, or residences.

OVERVIEW OF EMBODIMENTS OF FLUID HANDLING SYSTEMS

[0082] Disclosed herein are fluid handling systems and various methods of analyzing sample fluids. FIGURE 1 illustrates an embodiment of a fluid handling system **10** which can determine the concentration of one or more substances in a sample fluid, such as a whole blood sample from a patient **P**. The fluid handling system **10** can also deliver an infusion fluid **14** to the patient **P**.

[0078] The fluid handling system **10** is located bedside and generally comprises a container **15** holding the infusion fluid **14** and a sampling system **100** which is in communication with both the container **15** and the patient **P**. In some embodiments, the fluid handling system **10** can be in fluid communication with an extracorporeal fluid conduit containing a volume of a bodily fluid. A tube **13** extends from the container **15** to the sampling system **100**. A tube **12** extends from the sampling system **100** to the patient **P**. In some embodiments, in lieu of the depicted tube **12**, any suitable extracorporeal fluid conduit, such as a catheter, IV tube or an IV network, can be connected to the sampling system **100** with a connector such as the depicted connector **110**. The extracorporeal fluid conduit need not be attached to the patient **P**; for example, the extracorporeal fluid conduit can be in fluid communication with a container of bodily fluid of interest (e.g. blood), or the extracorporeal fluid conduit can serve as a stand-alone volume of the bodily fluid of interest. In some embodiments, one or more components of the fluid handling system **10** can be located at another facility, room, or other suitable remote location. One or more components of the fluid handling system **10** can communicate with one or more other components of the fluid handling system **10** (or with other devices) by any suitable communication means, such as communication interfaces including, but not limited to, optical interfaces, electrical interfaces, and wireless interfaces. These interfaces can be part of a local network, internet, wireless network, or other suitable networks.

[0083] The Infusion fluid **14** can comprise water, saline, dextrose, lactated Ringer's solution, drugs, insulin, mixtures thereof, or other suitable substances. The illustrated sampling system **100** allows the infusion fluid to pass to the patient **P** and/or uses the infusion fluid in the analysis. In some embodiments, the fluid handling system **10** may not employ infusion fluid. The fluid handling system **10** may thus draw samples without delivering any fluid to the patient **P**.

[0084] The sampling system 100 can be removably or permanently coupled to the tube 13 and tube 12 via connectors 110, 120. The patient connector 110 can selectively control the flow of fluid through a bundle 130, which includes a patient connection passageway 112 and a sampling passageway 113, as shown in FIGURE 1B. The sampling system 100 can also draw one or more samples from the patient P by any suitable means. The sampling system 100 can perform one or more analyses on the sample, and then returns the sample to the patient or a waste container. In some embodiments, the sampling system 100 is a modular unit that can be removed and replaced as desired. The sampling system 100 can include, but is not limited to, fluid handling and analysis apparatuses, connectors, passageways, catheters, tubing, fluid control elements, valves, pumps, fluid sensors, pressure sensors, temperature sensors, hematocrit sensors, hemoglobin sensors, colorimetric sensors, and gas (or “bubble”) sensors, fluid conditioning elements, gas injectors, gas filters, blood plasma separators, and/or communication devices (e.g., wireless devices) to permit the transfer of information within the sampling system or between sampling system 100 and a network. The illustrated sampling system 100 has a patient connector 110 and a fluid handling and analysis apparatus 140, which analyzes a sample drawn from the patient P. The fluid handling and analysis apparatus 140 and patient connector 110 cooperate to control the flow of infusion fluid into, and/or samples withdrawn from, the patient P. Samples can also be withdrawn and transferred in other suitable manners.

[0085] FIGURE 1A is a close up view of the fluid handling and analysis apparatus 140 which is partially cutaway to reveal some of its internal components. The fluid handling and analysis apparatus 140 preferably includes a pump 203 that controls the flow of fluid from the container 15 to the patient P and/or the flow of fluid drawn from the patient P. The pump 203 can selectively control fluid flow rates, direction(s) of fluid flow(s), and other fluid flow parameters as desired. As used herein, the term “pump” is a broad term and means, without limitation, a pressurization/pressure device, vacuum device, or any other suitable means for causing fluid flow. The pump 203 can include, but is not limited to, a reversible peristaltic pump, two unidirectional pumps that work in concert with valves to provide flow in two directions, a unidirectional pump, a displacement pump, a syringe, a diaphragm pump, roller pump, or other suitable pressurization device.

[0086] The illustrated fluid handling and analysis apparatus 140 has a display 141 and input devices 143. The illustrated fluid handling and analysis apparatus 140 can also have a sampling unit 200 configured to analyze the drawn fluid sample. The sampling

unit **200** can thus receive a sample, prepare the sample, and/or subject the sample (prepared or unprepared) to one or more tests. The sampling unit **200** can then analyze results from the tests. The sampling unit **200** can include, but is not limited to, separators, filters, centrifuges, sample elements, and/or detection systems, as described in detail below. The sampling unit **200** (see FIGURE 3) can include an analyte detection system for detecting the concentration of one or more analytes in the body fluid sample. In some embodiments, the sampling unit **200** can prepare a sample for analysis. If the fluid handling and analysis apparatus **140** performs an analysis on plasma contained in whole blood taken from the patient **P**, filters, separators, centrifuges, or other types of sample preparation devices can be used to separate plasma from other components of the blood. After the separation process, the sampling unit **200** can analyze the plasma to determine, for example, the patient **P**'s glucose level. The sampling unit **200** can employ spectroscopic methods, colorimetric methods, electrochemical methods, or other suitable methods for analyzing samples.

[0087] With continued reference to FIGURES 1 and 1A, the fluid **14** in the container **15** can flow through the tube **13** and into a fluid source passageway **111**. The fluid can further flow through the passageway **111** to the pump **203**, which can pressurize the fluid. The fluid **14** can then flow from the pump **203** through the patient connection passageway **112** and catheter **11** into the patient **P**. To analyze the patient's **P** body fluid (e.g., whole blood, blood plasma, interstitial fluid, bile, sweat, excretions, etc.), the fluid handling and analysis apparatus **140** can draw a sample from the patient **P** through the catheter **11** to a patient connector **110**. The patient connector **110** directs the fluid sample into the sampling passageway **113** which leads to the sampling unit **200**. The sampling unit **200** can perform one or more analyses on the sample. The fluid handling and analysis apparatus **140** can then output the results obtained by the sampling unit **200** on the display **141**.

[0088] In some embodiments, the fluid handling system **10** can draw and analyze body fluid sample(s) from the patient **P** to provide real-time or near-real-time measurement of glucose levels. Body fluid samples can be drawn from the patient **P** continuously, at regular intervals (e.g., every 5, 10, 15, 20, 30 or 60 minutes), at irregular intervals, or at any time or sequence for desired measurements. These measurements can be displayed bedside with the display **141** for convenient monitoring of the patient **P**.

[0089] The illustrated fluid handling system **10** is mounted to a stand **16** and can be used in hospitals, ICUs, residences, healthcare facilities, and the like. In some embodiments, the fluid handling system **10** can be transportable or portable for an ambulatory patient. The ambulatory fluid handling system **10** can be coupled (e.g., strapped, adhered, etc.) to a patient, and may be smaller than the bedside fluid handling system **10** illustrated in FIGURE 1. In some embodiments, the fluid handling system **10** is an implantable system sized for subcutaneous implantation and can be used for continuous monitoring. In some embodiments, the fluid handling system **10** is miniaturized so that the entire fluid handling system can be implanted. In other embodiments, only a portion of the fluid handling system **10** is sized for implantation.

[0090] In some embodiments, the fluid handling system **10** is a disposable fluid handling system and/or has one or more disposable components. As used herein, the term “disposable” when applied to a system or component (or combination of components), such as a cassette or sample element, is a broad term and means, without limitation, that the component in question is used a finite number of times and then discarded. Some disposable components are used only once and then discarded. Other disposable components are used more than once and then discarded. For example, the fluid handling and analysis apparatus **140** can have a main instrument and a disposable cassette that can be installed onto the main instrument, as discussed below. The disposable cassette can be used for predetermined length of time, to prepare a predetermined amount of sample fluid for analysis, etc. In some embodiments, the cassette can be used to prepare a plurality of samples for subsequent analyses by the main instrument. The reusable main instrument can be used with any number of cassettes as desired. Additionally or alternatively, the cassette can be a portable, handheld cassette for convenient transport. In these embodiments, the cassette can be manually mounted to or removed from the main instrument. In some embodiments, the cassette may be a non disposable cassette which can be permanently coupled to the main instrument, as discussed below.

[0091] Disclosed herein are a number of embodiments of fluid handling systems, sampling systems, fluid handling and analysis apparatuses, analyte detection systems, and methods of using the same. Section I below discloses various embodiments of the fluid handling system that may be used to transport fluid from a patient for analysis. Section II below discloses several embodiments of fluid handling methods that may be used with the apparatus discussed in Section I. Section III below discloses several embodiments

of a sampling system that may be used with the apparatus of Section I or the methods of Section II. Section IV below discloses various embodiments of a sample analysis system that may be used to detect the concentration of one or more analytes in a material sample. Section V below discloses methods for determining analyte concentrations from sample spectra.

SECTION I – FLUID HANDLING SYSTEM

[0092] FIGURE 1 is a schematic of the fluid handling system **10** which includes the container **15** supported by the stand **16** and having an interior that is fillable with the fluid **14**, the catheter **11**, and the sampling system **100**. Fluid handling system **10** includes one or more passageways **20** that form conduits between the container, the sampling system, and the catheter. Generally, sampling system **100** is adapted to accept a fluid supply, such as fluid **14**, and to be connected to a patient, including, but not limited to catheter **11** which is used to catheterize a patient **P**. Fluid **14** includes, but is not limited to, fluids for infusing a patient such as saline, lactated Ringer's solution, or water. Sampling system **100**, when so connected, is then capable of providing fluid to the patient. In addition, sampling system **100** is also capable of drawing samples, such as blood, from the patient through catheter **11** and passageways **20**, and analyzing at least a portion of the drawn sample. Sampling system **100** measures characteristics of the drawn sample including, but not limited to, one or more of the blood plasma glucose, blood urea nitrogen (BUN), hematocrit, hemoglobin, or lactate levels. Optionally, sampling system **100** includes other devices or sensors to measure other patient or apparatus related information including, but not limited to, patient blood pressure, pressure changes within the sampling system, or sample draw rate.

[0093] More specifically, FIGURE 1 shows sampling system **100** as including the patient connector **110**, the fluid handling and analysis apparatus **140**, and the connector **120**. Sampling system **100** may include combinations of passageways, fluid control and measurement devices, and analysis devices to direct, sample, and analyze fluid. Passageways **20** of sampling system **100** include the fluid source passageway **111** from connector **120** to fluid handling and analysis apparatus **140**, the patient connection passageway **112** from the fluid handling and analysis apparatus to patient connector **110**, and the sampling passageway **113** from the patient connector to the fluid handling and analysis apparatus. The reference of passageways **20** as including one or more passageway, for example passageways **111**, **112**, and **113** are provided to facilitate discussion of the

system. It is understood that passageways may include one or more separate components and may include other intervening components including, but not limited to, pumps, valves, manifolds, and analytic equipment.

[0094] As used herein, the term "passageway" is a broad term and is used in its ordinary sense and includes, without limitation except as explicitly stated, as any opening through a material through which a fluid, such as a liquid or a gas, may pass so as to act as a conduit. Passageways include, but are not limited to, flexible, inflexible or partially flexible tubes, laminated structures having openings, bores through materials, or any other structure that can act as a conduit and any combination or connections thereof. The internal surfaces of passageways that provide fluid to a patient or that are used to transport blood are preferably biocompatible materials, including but not limited to silicone, polyetheretherketone (PEEK), or polyethylene (PE). One type of preferred passageway is a flexible tube having a fluid contacting surface formed from a biocompatible material. A passageway, as used herein, also includes separable portions that, when connected, form a passageway.

[0095] The inner passageway surfaces may include coatings of various sorts to enhance certain properties of the conduit, such as coatings that affect the ability of blood to clot or to reduce friction resulting from fluid flow. Coatings include, but are not limited to, molecular or ionic treatments.

[0096] As used herein, the term "connected" is a broad term and is used in its ordinary sense and includes, without limitation except as explicitly stated, with respect to two or more things (e.g., elements, devices, patients, etc.): a condition of physical contact or attachment, whether direct, indirect (via, e.g., intervening member(s)), continuous, selective, or intermittent; and/or a condition of being in fluid, electrical, or optical-signal communication, whether direct, indirect, continuous, selective (e.g., where there exist one or more intervening valves, fluid handling components, switches, loads, or the like), or intermittent. A condition of fluid communication is considered to exist whether or not there exists a continuous or contiguous liquid or fluid column extending between or among the two or more things in question. Various types of connectors can connect components of the fluid handling system described herein. As used herein, the term "connector" is a broad term and is used in its ordinary sense and includes, without limitation except as explicitly stated, as a device that connects passageways or electrical wires to provide communication (whether direct, indirect, continuous, selective, or intermittent) on either side of the

connector. Connectors contemplated herein include a device for connecting any opening through which a fluid may pass. These connectors may have intervening valves, switches, fluid handling devices, and the like for affecting fluid flow. In some embodiments, a connector may also house devices for the measurement, control, and preparation of fluid, as described in several of the embodiments.

[0097] Fluid handling and analysis apparatus **140** may control the flow of fluids through passageways **20** and the analysis of samples drawn from a patient **P**, as described subsequently. Fluid handling and analysis apparatus **140** includes the display **141** and input devices, such as buttons **143**. Display **141** provides information on the operation or results of an analysis performed by fluid handling and analysis apparatus **140**. In one embodiment, display **141** indicates the function of buttons **143**, which are used to input information into fluid handling and analysis apparatus **140**. Information that may be input into or obtained by fluid handling and analysis apparatus **140** includes, but is not limited to, a required infusion or dosage rate, sampling rate, or patient specific information which may include, but is not limited to, a patient identification number or medical information. In an other alternative embodiment, fluid handling and analysis apparatus **140** obtains information on patient **P** over a communications network, for example an hospital communication network having patient specific information which may include, but is not limited to, medical conditions, medications being administered, laboratory blood reports, gender, and weight. As one example of the use of fluid handling system **10**, which is not meant to limit the scope of the present invention, FIGURE 1 shows catheter **11** connected to patient **P**.

[0098] As discussed subsequently, fluid handling system **10** may catheterize a patient's vein or artery. Sampling system **100** is releasably connectable to container **15** and catheter **11**. Thus, for example, FIGURE 1 shows container **15** as including the tube **13** to provide for the passage of fluid to, or from, the container, and catheter **11** as including the tube **12** external to the patient. Connector **120** is adapted to join tube **13** and passageway **111**. Patient connector **110** is adapted to join tube **12** and to provide for a connection between passageways **112** and **113**.

[0099] Patient connector **110** may also include one or more devices that control, direct, process, or otherwise affect the flow through passageways **112** and **113**. In some embodiments, one or more lines **114** are provided to exchange signals between patient connector **110** and fluid handling and analysis apparatus **140**. The lines **114** can be electrical lines, optical communicators, wireless communication channels, or other means

for communication. As shown in FIGURE 1, sampling system 100 may also include passageways 112 and 113, and lines 114. The passageways and electrical lines between apparatus 140 and patient connector 110 are referred to, with out limitation, as the bundle 130.

[0100] In various embodiments, fluid handling and analysis apparatus 140 and/or patient connector 110, includes other elements (not shown in FIGURE 1) that include, but are not limited to: fluid control elements, including but not limited to valves and pumps; fluid sensors, including but not limited to pressure sensors, temperature sensors, hematocrit sensors, hemoglobin sensors, colorimetric sensors, and gas (or “bubble”) sensors; fluid conditioning elements, including but not limited to gas injectors, gas filters, and blood plasma separators; and wireless communication devices to permit the transfer of information within the sampling system or between sampling system 100 and a wireless network.

[0101] In one embodiment, patient connector 110 includes devices to determine when blood has displaced fluid 14 at the connector end, and thus provides an indication of when a sample is available for being drawn through passageway 113 for sampling. The presence of such a device at patient connector 110 allows for the operation of fluid handling system 10 for analyzing samples without regard to the actual length of tube 12. Accordingly, bundle 130 may include elements to provide fluids, including air, or information communication between patient connector 110 and fluid handling and analysis apparatus 140 including, but not limited to, one or more other passageways and/or wires.

[0102] In one embodiment of sampling system 100, the passageways and lines of bundle 130 are sufficiently long to permit locating patient connector 110 near patient P, for example with tube 12 having a length of less than 0.1 to 0.5 meters, or preferably approximately 0.15 meters and with fluid handling and analysis apparatus 140 located at a convenient distance, for example on a nearby stand 16. Thus, for example, bundle 130 is from 0.3 to 3 meters, or more preferably from 1.5 to 2.0 meters in length. It is preferred, though not required, that patient connector 110 and connector 120 include removable connectors adapted for fitting to tubes 12 and 13, respectively. Thus, in one embodiment, container 15/tube 13 and catheter 11/tube 12 are both standard medical components, and sampling system 100 allows for the easy connection and disconnection of one or both of the container and catheter from fluid handling system 10.

[0103] In another embodiment of sampling system 100, tubes 12 and 13 and a substantial portion of passageways 111 and 112 have approximately the same internal cross-sectional area. It is preferred, though not required, that the internal cross-sectional area of passageway 113 is less than that of passageways 111 and 112 (see FIGURE 1B). As described subsequently, the difference in areas permits fluid handling system 10 to transfer a small sample volume of blood from patient connector 110 into fluid handling and analysis apparatus 140.

[0104] Thus, for example, in one embodiment passageways 111 and 112 are formed from a tube having an inner diameter from 0.3 millimeter to 1.50 millimeter, or more preferably having a diameter from 0.60 millimeter to 1.2 millimeter. Passageway 113 is formed from a tube having an inner diameter from 0.3 millimeter to 1.5 millimeter, or more preferably having an inner diameter of from 0.6 millimeter to 1.2 millimeter.

[0105] While FIGURE 1 shows sampling system 100 connecting a patient to a fluid source, the scope of the present disclosure is not meant to be limited to this embodiment. Alternative embodiments include, but are not limited to, a greater or fewer number of connectors or passageways, or the connectors may be located at different locations within fluid handling system 10, and alternate fluid paths. Thus, for example, passageways 111 and 112 may be formed from one tube, or may be formed from two or more coupled tubes including, for example, branches to other tubes within sampling system 100, and/or there may be additional branches for infusing or obtaining samples from a patient. In addition, patient connector 110 and connector 120 and sampling system 100 alternatively include additional pumps and/or valves to control the flow of fluid as described below.

[0106] FIGURES 1A and 2 illustrate a sampling system 100 configured to analyze blood from patient P which may be generally similar to the embodiment of the sampling system illustrated in FIGURE 1, except as further detailed below. Where possible, similar elements are identified with identical reference numerals in the depiction of the embodiments of FIGURES 1 to 2. FIGURES 1A and 2 show patient connector 110 as including a sampling assembly 220 and a connector 230, portions of passageways 111 and 113, and lines 114, and fluid handling and analysis apparatus 140 as including the pump 203, the sampling unit 200, and a controller 210. The pump 203, sampling unit 200, and controller 210 are contained within a housing 209 of the fluid handling and analysis apparatus 140. The passageway 111 extends from the connector 120 through the housing

209 to the pump 203. The bundle 130 extends from the pump 203, sampling unit 200, and controller 210 to the patient connector 110.

[0107] In FIGURES 1A and 2, the passageway 111 provides fluid communication between connector 120 and pump 203 and passageway 113 provides fluid communication between pump 203 and connector 110. Controller 210 is in communication with pump 203, sampling unit 200, and sampling assembly 220 through lines 114. Controller 210 has access to memory 212, and optionally has access to a media reader 214, including but not limited to a DVD or CD-ROM reader, and communications link 216, which can comprise a wired or wireless communications network, including but not limited to a dedicated line, an intranet, or an Internet connection.

[0108] As described subsequently in several embodiments, sampling unit 200 may include one or more passageways, pumps and/or valves, and sampling assembly 220 may include passageways, sensors, valves, and/or sample detection devices. Controller 210 collects information from sensors and devices within sampling assembly 220, from sensors and analytical equipment within sampling unit 200, and provides coordinated signals to control pump 203 and pumps and valves, if present, in sampling assembly 220.

[0109] Fluid handling and analysis apparatus 140 includes the ability to pump in a forward direction (towards the patient) and in a reverse direction (away from the patient). Thus, for example, pump 203 may direct fluid 14 into patient P or draw a sample, such as a blood sample from patient P, from catheter 11 to sampling assembly 220, where it is further directed through passageway 113 to sampling unit 200 for analysis. Preferably, pump 203 provides a forward flow rate at least sufficient to keep the patient vascular line open. In one embodiment, the forward flow rate is from 1 to 5 ml/hr. In some embodiments, the flow rate of fluid is about 0.05 ml/hr, 0.1 ml/hr, 0.2 ml/hr, 0.4 ml/hr, 0.6 ml/hr, 0.8 ml/hr, 1.0 ml/hr, and ranges encompassing such flow rates. In some embodiments, for example, the flow rate of fluid is less than about 1.0 ml/hr. In certain embodiments, the flow rate of fluid may be about 0.1 ml/hr or less. When operated in a reverse direction, fluid handling and analysis apparatus 140 includes the ability to draw a sample from the patient to sampling assembly 220 and through passageway 113. In one embodiment, pump 203 provides a reverse flow to draw blood to sampling assembly 220, preferably by a sufficient distance past the sampling assembly to ensure that the sampling assembly contains an undiluted blood sample. In one embodiment, passageway 113 has an inside diameter of from 25 to 200 microns, or more preferably from 50 to 100 microns. Sampling unit 200 extracts a

small sample, for example from 10 to 100 microliters of blood, or more preferably approximately 40 microliters volume of blood, from sampling assembly 220.

[0110] In one embodiment, pump 203 is a directionally controllable pump that acts on a flexible portion of passageway 111. Examples of a single, directionally controllable pump include, but are not limited to a reversible peristaltic pump or two unidirectional pumps that work in concert with valves to provide flow in two directions. In an alternative embodiment, pump 203 includes a combination of pumps, including but not limited to displacement pumps, such as a syringe, and/or valve to provide bi-directional flow control through passageway 111.

[0111] Controller 210 includes one or more processors for controlling the operation of fluid handling system 10 and for analyzing sample measurements from fluid handling and analysis apparatus 140. Controller 210 also accepts input from buttons 143 and provides information on display 141. Optionally, controller 210 is in bi-directional communication with a wired or wireless communication system, for example a hospital network for patient information. The one or more processors comprising controller 210 may include one or more processors that are located either within fluid handling and analysis apparatus 140 or that are networked to the unit.

[0112] The control of fluid handling system 10 by controller 210 may include, but is not limited to, controlling fluid flow to infuse a patient and to sample, prepare, and analyze samples. The analysis of measurements obtained by fluid handling and analysis apparatus 140 of may include, but is not limited to, analyzing samples based on inputted patient specific information, from information obtained from a database regarding patient specific information, or from information provided over a network to controller 210 used in the analysis of measurements by apparatus 140.

[0113] Fluid handling system 10 provides for the infusion and sampling of a patient blood as follows. With fluid handling system 10 connected to bag 15 having fluid 14 and to a patient P, controller 210 infuses a patient by operating pump 203 to direct the fluid into the patient. Thus, for example, in one embodiment, the controller directs that samples be obtained from a patient by operating pump 203 to draw a sample. In one embodiment, pump 203 draws a predetermined sample volume, sufficient to provide a sample to sampling assembly 220. In another embodiment, pump 203 draws a sample until a device within sampling assembly 220 indicates that the sample has reached the patient connector 110. As an example which is not meant to limit the scope of the present

invention, one such indication is provided by a sensor that detects changes in the color of the sample. Another example is the use of a device that indicates changes in the material within passageway 111 including, but not limited to, a decrease in the amount of fluid 14, a change with time in the amount of fluid, a measure of the amount of hemoglobin, or an indication of a change from fluid to blood in the passageway.

[0114] When the sample reaches sampling assembly 220, controller 210 provides an operating signal to valves and/or pumps in sampling system 100 (not shown) to draw the sample from sampling assembly 220 into sampling unit 200. After a sample is drawn towards sampling unit 200, controller 210 then provides signals to pump 203 to resume infusing the patient. In one embodiment, controller 210 provides signals to pump 203 to resume infusing the patient while the sample is being drawn from sampling assembly 220. In an alternative embodiment, controller 210 provides signals to pump 203 to stop infusing the patient while the sample is being drawn from sampling assembly 220. In another alternative embodiment, controller 210 provides signals to pump 203 to slow the drawing of blood from the patient while the sample is being drawn from sampling assembly 220.

[0115] In another alternative embodiment, controller 210 monitors indications of obstructions in passageways or catheterized blood vessels during reverse pumping and moderates the pumping rate and/or direction of pump 203 accordingly. Thus, for example, obstructed flow from an obstructed or kinked passageway or of a collapsing or collapsed catheterized blood vessel that is being pumped will result in a lower pressure than an unobstructed flow. In one embodiment, obstructions are monitored using a pressure sensor in sampling assembly 220 or along passageways 20. If the pressure begins to decrease during pumping, or reaches a value that is lower than a predetermined value then controller 210 directs pump 203 to decrease the reverse pumping rate, stop pumping, or pump in the forward direction in an effort to reestablish unobstructed pumping.

[0116] FIGURE 3 is a schematic showing details of a sampling system 300 which may be generally similar to the embodiments of sampling system 100 as illustrated in FIGURES 1 and 2, except as further detailed below. Sampling system 300 includes sampling assembly 220 having, along passageway 112: connector 230 for connecting to tube 12, a pressure sensor 317, a colorimetric sensor 311, a first bubble sensor 314a, a first valve 312, a second valve 313, and a second bubble sensor 314b. Passageway 113 forms a "T" with passageway 111 at a junction 318 that is positioned between the first valve 312

and second valve 313, and includes a gas injector manifold 315 and a third valve 316. The lines 114 comprise control and/or signal lines extending from colorimetric sensor 311, first, second, and third valves (312, 313, 316), first and second bubble sensors (314a, 314b), gas injector manifold 315, and pressure sensor 317. Sampling system 300 also includes sampling unit 200 which has a bubble sensor 321, a sample analysis device 330, a first valve 323a, a waste receptacle 325, a second valve 323b, and a pump 328. Passageway 113 forms a "T" to form a waste line 324 and a pump line 327.

[0117] It is preferred, though not necessary, that the sensors of sampling system 100 are adapted to accept a passageway through which a sample may flow and that sense through the walls of the passageway. As described subsequently, this arrangement allows for the sensors to be reusable and for the passageways to be disposable. It is also preferred, though not necessary, that the passageway is smooth and without abrupt dimensional changes which may damage blood or prevent smooth flow of blood. In addition, is also preferred that the passageways that deliver blood from the patient to the analyzer not contain gaps or size changes that permit fluid to stagnate and not be transported through the passageway.

[0118] In one embodiment, the respective passageways on which valves 312, 313, 316, and 323 are situated along passageways that are flexible tubes, and valves 312, 313, 316, and 323 are "pinch valves," in which one or more movable surfaces compress the tube to restrict or stop flow therethrough. In one embodiment, the pinch valves include one or more moving surfaces that are actuated to move together and "pinch" a flexible passageway to stop flow therethrough. Examples of a pinch valve include, for example, Model PV256 Low Power Pinch Valve (Instech Laboratories, Inc., Plymouth Meeting, PA). Alternatively, one or more of valves 312, 313, 316, and 323 may be other valves for controlling the flow through their respective passageways.

[0119] Colorimetric sensor 311 accepts or forms a portion of passageway 111 and provides an indication of the presence or absence of blood within the passageway. In one embodiment, colorimetric sensor 311 permits controller 210 to differentiate between fluid 14 and blood. Preferably, colorimetric sensor 311 is adapted to receive a tube or other passageway for detecting blood. This permits, for example, a disposable tube to be placed into or through a reusable colorimetric sensor. In an alternative embodiment, colorimetric sensor 311 is located adjacent to bubble sensor 314b. Examples of a colorimetric sensor

include, for example, an Optical Blood Leak/Blood vs. Saline Detector available from Introtek International (Edgewood, NJ).

[0120] As described subsequently, sampling system **300** injects a gas – referred to herein and without limitation as a “bubble” – into passageway **113**. Sampling system **300** includes gas injector manifold **315** at or near junction **318** to inject one or more bubbles, each separated by liquid, into passageway **113**. The use of bubbles is useful in preventing longitudinal mixing of liquids as they flow through passageways both in the delivery of a sample for analysis with dilution and for cleaning passageways between samples. Thus, for example the fluid in passageway **113** includes, in one embodiment of the invention, two volumes of liquids, such as sample **S** or fluid **14** separated by a bubble, or multiple volumes of liquid each separated by a bubble therebetween.

[0121] Bubble sensors **314a**, **314b** and **321** each accept or form a portion of passageway **112** or **113** and provide an indication of the presence of air, or the change between the flow of a fluid and the flow of air, through the passageway. Examples of bubble sensors include, but are not limited to ultrasonic or optical sensors, that can detect the difference between small bubbles or foam from liquid in the passageway. Once such bubble detector is an MEC Series Air Bubble/ Liquid Detection Sensor (Introtek International, Edgewood, NY). Preferably, bubble sensor **314a**, **314b**, and **321** are each adapted to receive a tube or other passageway for detecting bubbles. This permits, for example, a disposable tube to be placed through a reusable bubble sensor.

[0122] Pressure sensor **317** accepts or forms a portion of passageway **111** and provides an indication or measurement of a fluid within the passageway. When all valves between pressure sensor **317** and catheter **11** are open, pressure sensor **317** provides an indication or measurement of the pressure within the patient’s catheterized blood vessel. In one embodiment, the output of pressure sensor **317** is provided to controller **210** to regulate the operation of pump **203**. Thus, for example, a pressure measured by pressure sensor **317** above a predetermined value is taken as indicative of a properly working system, and a pressure below the predetermined value is taken as indicative of excessive pumping due to, for example, a blocked passageway or blood vessel. Thus, for example, with pump **203** operating to draw blood from patient **P**, if the pressure as measured by pressure sensor **317** is within a range of normal blood pressures, it may be assumed that blood is being drawn from the patient and pumping continues. However, if the pressure as measured by pressure sensor **317** falls below some level, then controller **210** instructs pump **203** to slow or to be

operated in a forward direction to reopen the blood vessel. One such pressure sensor is a Deltran IV part number DPT-412 (Utah Medical Products, Midvale, UT).

[0123] Sample analysis device 330 receives a sample and performs an analysis. In several embodiments, device 330 is configured to prepare of the sample for analysis. Thus, for example, device 330 may include a sample preparation unit 332 and an analyte detection system 334, where the sample preparation unit is located between the patient and the analyte detection system. In general, sample preparation occurs between sampling and analysis. Thus, for example, sample preparation unit 332 may take place removed from analyte detection, for example within sampling assembly 220, or may take place adjacent or within analyte detection system 334.

[0124] As used herein, the term “analyte” is a broad term and is used in its ordinary sense and includes, without limitation, any chemical species the presence or concentration of which is sought in the material sample by an analyte detection system. For example, the analyte(s) include, but not are limited to, glucose, ethanol, insulin, water, carbon dioxide, blood oxygen, cholesterol, bilirubin, ketones, fatty acids, lipoproteins, albumin, urea, creatinine, white blood cells, red blood cells, hemoglobin, oxygenated hemoglobin, carboxyhemoglobin, organic molecules, inorganic molecules, pharmaceuticals, cytochrome, various proteins and chromophores, microcalcifications, electrolytes, sodium, potassium, chloride, bicarbonate, and hormones. As used herein, the term “material sample” (or, alternatively, “sample”) is a broad term and is used in its ordinary sense and includes, without limitation, any collection of material which is suitable for analysis. For example, a material sample may comprise whole blood, blood components (e.g., plasma or serum), interstitial fluid, intercellular fluid, saliva, urine, sweat and/or other organic or inorganic materials, or derivatives of any of these materials. In one embodiment, whole blood or blood components may be drawn from a patient’s capillaries.

[0125] In one embodiment, sample preparation unit 332 separates blood plasma from a whole blood sample or removes contaminants from a blood sample and thus comprises one or more devices including, but not limited to, a filter, membrane, centrifuge, or some combination thereof. In alternative embodiments, analyte detection system 334 is adapted to analyze the sample directly and sample preparation unit 332 is not required.

[0126] Generally, sampling assembly 220 and sampling unit 200 direct the fluid drawn from sampling assembly 220 into passageway 113 into sample analysis device 330. FIGURE 4 is a schematic of an embodiment of a sampling unit 400 that permits some of

the sample to bypass sample analysis device 330. Sampling unit 400 may be generally similar to sampling unit 200, except as further detailed below. Sampling unit 400 includes bubble sensor 321, valve 323, sample analysis device 330, waste line 324, waste receptacle 325, valve 326, pump line 327, pump 328, a valve 322, and a waste line 329. Waste line 329 includes valve 322 and forms a "T" at pump line 337 and waste line 329. Valves 316, 322, 323, and 326 permit a flow through passageway 113 to be routed through sample analysis device 330, to be routed to waste receptacle 325, or to be routed through waste line 324 to waste receptacle 325.

[0127] FIGURE 5 is a schematic of one embodiment of a sampling system 500 which may be generally similar to the embodiments of sampling system 100 or 300 as illustrated in FIGURES 1 through 4, except as further detailed below. Sampling system 500 includes an embodiment of a sampling unit 510 and differs from sampling system 300 in part, in that liquid drawn from passageway 111 may be returned to passageway 111 at a junction 502 between pump 203 and connector 120.

[0128] With reference to FIGURE 5, sampling unit 510 includes a return line 503 that intersects passageway 111 on the opposite side of pump 203 from passageway 113, a bubble sensor 505 and a pressure sensor 507, both of which are controlled by controller 210. Bubble sensor 505 is generally similar to bubble sensors 314a, 314b and 321 and pressure sensor 507 is generally similar to pressure sensor 317. Pressure sensor 507 is useful in determining the correct operation of sampling system 500 by monitoring pressure in passageway 111. Thus, for example, the pressure in passageway 111 is related to the pressure at catheter 11 when pressure sensor 507 is in fluid communication with catheter 11 (that is, when any intervening valve(s) are open). The output of pressure sensor 507 is used in a manner similar to that of pressure sensor 317 described previously in controlling pumps of sampling system 500.

[0129] Sampling unit 510 includes valves 501, 326a, and 326b under the control of controller 210. Valve 501 provides additional liquid flow control between sampling unit 200 and sampling unit 510. Pump 328 is preferably a bi-directional pump that can draw fluid from and into passageway 113. Fluid may either be drawn from and returned to passageway 501, or may be routed to waste receptacle 325. Valves 326a and 326b are situated on either side of pump 328. Fluid can be drawn through passageway 113 and into return line 503 by the coordinated control of pump 328 and valves 326a and 326b. Directing flow from return line 503 can be used to prime sampling system 500 with fluid.

Thus, for example, liquid may be pulled into sampling unit **510** by operating pump **328** to pull liquid from passageway **113** while valve **326a** is open and valve **326b** is closed. Liquid may then be pumped back into passageway **113** by operating pump **328** to push liquid into passageway **113** while valve **326a** is closed and valve **326b** is open.

[0130] FIGURE 6A is a schematic of an embodiment of gas injector manifold **315** which may be generally similar or included within the embodiments illustrated in FIGURES 1 through 5, except as further detailed below. Gas injector manifold **315** is a device that injects one or more bubbles in a liquid within passageway **113** by opening valves to the atmosphere and lowering the liquid pressure within the manifold to draw in air. As described subsequently, gas injector manifold **315** facilitates the injection of air or other gas bubbles into a liquid within passageway **113**. Gas injector manifold **315** has three gas injectors **610** including a first injector **610a**, a second injector **610b**, and a third injector **610c**. Each injector **610** includes a corresponding passageway **611** that begins at one of several laterally spaced locations along passageway **113** and extends through a corresponding valve **613** and terminates at a corresponding end **615** that is open to the atmosphere. In an alternative embodiment, a filter is placed in end **615** to filter out dust or particles in the atmosphere. As described subsequently, each injector **610** is capable of injecting a bubble into a liquid within passageway **113** by opening the corresponding valve **613**, closing a valve on one end of passageway **113** and operating a pump on the opposite side of the passageway to lower the pressure and pull atmospheric air into the fluid. In one embodiment of gas injector manifold **315**, passageways **113** and **611** are formed within a single piece of material (e.g., as bores formed in or through a plastic or metal housing (not shown)). In an alternative embodiment, gas injector manifold **315** includes fewer than three injectors, for example one or two injectors, or includes more than three injectors. In another alternative embodiment, gas injector manifold **315** includes a controllable high pressure source of gas for injection into a liquid in passageway **113**. It is preferred that valves **613** are located close to passageway **113** to minimize trapping of fluid in passageways **611**.

[0131] Importantly, gas injected into passageways **20** should be prevented from reaching catheter **11**. As a safety precaution, one embodiment prevents gas from flowing towards catheter **11** by the use of bubble sensor **314a** as shown, for example, in FIGURE 3. If bubble sensor **314a** detects gas within passageway **111**, then one of several alternative embodiments prevents unwanted gas flow. In one embodiment, flow in the vicinity of sampling assembly **220** is directed into line **113** or through line **113** into waste receptacle

325. With further reference to FIGURE 3, upon the detection of gas by bubble sensor 314a, valves 316 and 323a are opened, valve 313 and the valves 613a, 613b and 613c of gas injector manifold 315 are closed, and pump 328 is turned on to direct flow away from the portion of passageway 111 between sampling assembly 220 and patient P into passageway 113. Bubble sensor 321 is monitored to provide an indication of when passageway 113 clears out. Valve 313 is then opened, valve 312 is closed, and the remaining portion of passageway 111 is then cleared. Alternatively, all flow is immediately halted in the direction of catheter 11, for example by closing all valves and stopping all pumps. In an alternative embodiment of sampling assembly 220, a gas-permeable membrane is located within passageway 113 or within gas injector manifold 315 to remove unwanted gas from fluid handling system 10, e.g., by venting such gas through the membrane to the atmosphere or a waste receptacle.

[0132] FIGURE 6B is a schematic of an embodiment of gas injector manifold 315' which may be generally similar to, or included within, the embodiments illustrated in FIGURES 1 through 6A, except as further detailed below. In gas injector manifold 315', air line 615 and passageway 113 intersect at junction 318. Bubbles are injected by opening valve 316 and 613 while drawing fluid into passageway 113. Gas injector manifold 315' is thus more compact than gas injector manifold 315, resulting in a more controllable and reliable gas generator.

SECTION II – FLUID HANDLING METHODS

[0133] One embodiment of a method of using fluid handling system 10, including sampling assembly 220 and sampling unit 200 of FIGURES 2, 3 and 6A, is illustrated in Table 1 and in the schematic fluidic diagrams of FIGURES 7A-7J. In general, the pumps and valves are controlled to infuse a patient, to extract a sample from the patient up passageway 111 to passageway 113, and to direct the sample along passageway 113 to device 330. In addition, the pumps and valves are controlled to inject bubbles into the fluid to isolate the fluid from the diluting effect of previous fluid and to clean the lines between sampling. The valves in FIGURES 7A-7J are labeled with suffices to indicate whether the valve is open or closed. Thus a valve "x," for example, is shown as valve "x-o" if the valve is open and "x-c" if the valve is closed.

Mode	Step	Pump 203	Pump 328	Valve 312	Valve 313	Valve 613a	Valve 613b	Valve 613c	Valve 316	Valve 323a	Valve 323b
Infuse patient	(FIGURE 7A) Infuse patient	F	Off	O	O	C	C	C	C	C	C
Sample patient	(FIGURE 7B) Clear fluid from passageways	R	Off	C	O	one or more are open			C	C	C
						O	O	O			
	(FIGURE 7C) Draw sample until after colorimetric sensor 311 senses blood	R	Off	O	O	C	C	C	C	C	C
	(FIGURE 7D) Inject sample into bubble manifold	Off	On	O	C	C	C	C	O	C	O
	Alternative to FIGURE 7D	R	On	O	O	C	C	C	O	C	O
	(FIGURE 7E) Inject bubbles	Off	On	C	C	sequentially			O	C	O
						O	O	O			
	(FIGURE 7F) Clear bubbles from patient line	F	Off	C	O	C	C	C	O	O	C
	(FIGURE 7G) Clear blood from patient line	F	Off	O	O	C	C	C	C	C	C
	(FIGURE 7H) Move bubbles out of bubbler	F	Off	C	O	C	C	C	O	O	C
	(FIGURE 7I) Add cleaning bubbles	Off	On	C	C	sequentially			O	C	O
						O	O	O			
	(FIGURE 7J) Push sample to analyzer until bubble sensor 321 detects bubble	F	Off	C	O	C	C	C	O	O	C

F = Forward (fluid into patient), R = Reverse (fluid from patient), O = Open, C = Closed

Table 1. Methods of operating system 10 as illustrated in FIGURES 7A-7J

[0134] FIGURE 7A illustrates one embodiment of a method of infusing a patient. In the step of FIGURE 7A, pump 203 is operated forward (pumping towards the patient) pump 328 is off, or stopped, valves 313 and 312 are open, and valves 613a, 613b, 613c, 316, 323a, and 323b are closed. With these operating conditions, fluid 14 is provided to patient P. In a preferred embodiment, all of the other passageways at the time of the step of FIGURE 7A substantially contain fluid 14.

[0135] The next nine figures (FIGURES 7B-7J) illustrate steps in a method of sampling from a patient. The following steps are not meant to be inclusive of all of the steps of sampling from a patient, and it is understood that alternative embodiments may include more steps, fewer steps, or a different ordering of steps. FIGURE 7B illustrates a first sampling step, where liquid is cleared from a portion of patient connection passageway and sampling passageways 112 and 113. In the step of FIGURE 7B, pump 203 is operated in reverse (pumping away from the patient), pump 328 is off, valve 313 is open, one or more of valves 613a, 613b, and 613c are open, and valves 312, 316, 323a, and 326b are closed. With these operating conditions, air 701 is drawn into sampling passageway 113 and back into patient connection passageway 112 until bubble sensor 314b detects the presence of the air.

[0136] FIGURE 7C illustrates a second sampling step, where a sample is drawn from patient P into patient connection passageway 112. In the step of FIGURE 7C, pump 203 is operated in reverse, pump 328 is off, valves 312 and 313 are open, and valves 316, 613a, 613b, 613c, 323a, and 323b are closed. Under these operating conditions, a sample S is drawn into passageway 112, dividing air 701 into air 701a within sampling passageway 113 and air 701b within the patient connection passageway 112. Preferably this step proceeds until sample S extends just past the junction of passageways 112 and 113. In one embodiment, the step of FIGURE 7C proceeds until variations in the output of colorimetric sensor 311 indicate the presence of a blood (for example by leveling off to a constant value), and then proceeds for an additional set amount of time to ensure the presence of a sufficient volume of sample S.

[0137] FIGURE 7D illustrates a third sampling step, where a sample is drawn into sampling passageway 113. In the step of FIGURE 7D, pump 203 is off, or stopped, pump 328 is on, valves 312, 316, and 326b are open, and valves 313, 613a, 613b, 613c and 323a are closed. Under these operating conditions, blood is drawn into passageway 113.

Preferably, pump **328** is operated to pull a sufficient amount of sample **S** into passageway **113**. In one embodiment, pump **328** draws a sample **S** having a volume from 30 to 50 microliters. In an alternative embodiment, the sample is drawn into both passageways **112** and **113**. Pump **203** is operated in reverse, pump **328** is on, valves **312**, **313**, **316**, and **323b** are open, and valves **613a**, **613b**, **613c** and **323a** are closed to ensure fresh blood in sample **S**.

[0138] FIGURE 7E illustrates a fourth sampling step, where air is injected into the sample. Bubbles which span the cross-sectional area of sampling passageway **113** are useful in preventing contamination of the sample as it is pumped along passageway **113**. In the step of FIGURE 7E, pump **203** is off, or stopped, pump **328** is on, valves **316**, and **323b** are open, valves **312**, **313** and **323a** are closed, and valves **613a**, **613b**, **613c** are each opened and closed sequentially to draw in three separated bubbles. With these operating conditions, the pressure in passageway **113** falls below atmospheric pressure and air is drawn into passageway **113**. Alternatively, valves **613a**, **613b**, **613c** may be opened simultaneously for a short period of time, generating three spaced bubbles. As shown in FIGURE 7E, injectors **610a**, **610b**, and **610c** inject bubbles **704**, **703**, and **702**, respectively, dividing sample **S** into a forward sample **S1**, a middle sample **S2**, and a rear sample **S3**.

[0139] FIGURE 7F illustrates a fifth sampling step, where bubbles are cleared from patient connection passageway **112**. In the step of FIGURE 7F, pump **203** is operated in a forward direction, pump **328** is off, valves **313**, **316**, and **323a** are open, and valves **312**, **613a**, **613b**, **613c**, and **323b** are closed. With these operating conditions, the previously injected air **701b** is drawn out of first passageway **111** and into second passageway **113**. This step proceeds until air **701b** is in passageway **113**.

[0140] FIGURE 7G illustrates a sixth sampling step, where blood in passageway **112** is returned to the patient. In the step of FIGURE 7G, pump **203** is operated in a forward direction, pump **328** is off, valves **312** and **313** are open, and valves **316**, **323a**, **613a**, **613b**, **613c** and **323b** are closed. With these operating conditions, the previously injected air remains in passageway **113** and passageway **111** is filled with fluid **14**.

[0141] FIGURES 7H and 7I illustrates a seventh and eighth sampling steps, where the sample is pushed part way into passageway **113** followed by fluid **14** and more bubbles. In the step of FIGURE 7H, pump **203** is operated in a forward direction, pump **328** is off, valves **313**, **316**, and **323a** are open, and valves **312**, **613a**, **613b**, **613c**, and **323b** are closed. With these operating conditions, sample **S** is moved partway into passageway **113**

with bubbles injected, either sequentially or simultaneously, into fluid 14 from injectors 610a, 610b, and 610c. In the step of FIGURE 7I, the pumps and valves are operated as in the step of FIGURE 7E, and fluid 14 is divided into a forward solution C1, a middle solution C2, and a rear solution C3 separated by bubbles 705, 706, and 707.

[0142] The last step shown in FIGURE 7 is FIGURE 7J, where middle sample S2 is pushed to sample analysis device 330. In the step of FIGURE 7J, pump 203 is operated in a forward direction, pump 328 is off, valves 313, 316, and 323a are open, and valves 312, 613a, 613b, 613c, and 323b are closed. In this configuration, the sample is pushed into passageway 113. When bubble sensor 321 detects bubble 702, pump 203 continues pumping until sample S2 is taken into device sample analysis 330. Additional pumping using the settings of the step of FIGURE 7J permits the sample S2 to be analyzed and for additional bubbles and solutions to be pushed into waste receptacle 325, cleansing passageway 113 prior to accepting a next sample.

SECTION III – SAMPLING SYSTEM

[0143] FIGURE 8 is a perspective front view of a third embodiment of a sampling system 800 which may be generally similar to sampling system 100, 300 or 500 and the embodiments illustrated in FIGURES 1 through 7, except as further detailed below. The fluid handling and analysis apparatus 140 of sampling system 800 includes the combination of an instrument 810 and a sampling system cassette 820. FIGURE 8 illustrates instrument 810 and cassette 820 partially removed from each other. Instrument 810 includes controller 210 (not shown), display 141 and input devices 143, a cassette interface 811, and lines 114. Cassette 820 includes passageway 111 which extends from connector 120 to connector 230, and further includes passageway 113, a junction 829 of passageways 111 and 113, an instrument interface 821, a front surface 823, an inlet 825 for passageway 111, and an inlet 827 for passageways 111 and 113. In addition, sampling assembly 220 is formed from a sampling assembly instrument portion 813 having an opening 815 for accepting junction 829. The interfaces 811 and 821 engage the components of instrument 810 and cassette 820 to facilitate pumping fluid and analyzing samples from a patient, and sampling assembly instrument portion 813 accepts junction 829 in opening 815 to provide for sampling from passageway 111.

[0144] FIGURES 9 and 10 are front views of a sampling system cassette 820 and instrument 810, respectively, of a sampling system 800. Cassette 820 and instrument

810, when assembled, form various components of FIGURES 9 and 10 that cooperate to form an apparatus consisting of sampling unit **510** of FIGURE 5, sampling assembly **220** of FIGURE 3, and gas injection manifold **315'** of FIGURE 6B.

[0145] More specifically, as shown in FIGURE 9, cassette **820** includes passageways **20** including: passageway **111** having portions **111a**, **112a**, **112b**, **112c**, **112d**, **112e**, and **112f**; passageway **113** having portions **113a**, **113b**, **113c**, **113d**, **113e**, and **113f**; passageway **615**; waste receptacle **325**; disposable components of sample analysis device **330** including, for example, a sample preparation unit **332** adapted to allow only blood plasma to pass therethrough and a sample chamber **903** for placement within analyte detection system **334** for measuring properties of the blood plasma; and a displacement pump **905** having a piston control **907**.

[0146] As shown in FIGURE 10, instrument **810** includes bubble sensor units **1001a**, **1001b**, and **1001c**, colorimetric sensor, which is a hemoglobin sensor unit **1003**, a peristaltic pump roller **1005a** and a roller support **1005b**, pincher pairs **1007a**, **1007b**, **1007c**, **1007d**, **1007e**, **1007f**, **1007g**, and **1007h**, an actuator **1009**, and a pressure sensor unit **1011**. In addition, instrument **810** includes portions of sample analysis device **330** which are adapted to measure a sample contained within sample chamber **903** when located near or within a probe region **1002** of an optical analyte detection system **334**.

[0147] Passageway portions of cassette **820** contact various components of instrument **810** to form sampling system **800**. With reference to FIGURE 5 for example, pump **203** is formed from portion **111a** placed between peristaltic pump roller **1005a** and roller support **1005b** to move fluid through passageway **111** when the roller is actuated; valves **501**, **323**, **326a**, and **326b** are formed with pincher pairs **1007a**, **1007b**, **1007c**, and **1007d** surrounding portions **113a**, **113c**, **113d**, and **113e**, respectively, to permit or block fluid flow therethrough. Pump **328** is formed from actuator **1009** positioned to move piston control **907**. It is preferred that the interconnections between the components of cassette **820** and instrument **810** described in this paragraph are made with one motion. Thus for example the placement of interfaces **811** and **821** places the passageways against and/or between the sensors, actuators, and other components.

[0148] In addition to placement of interface **811** against interface **821**, the assembly of apparatus **800** includes assembling sampling assembly **220**. More specifically, an opening **815a** and **815b** are adapted to receive passageways **111** and **113**, respectively, with junction **829** within sampling assembly instrument portion **813**. Thus, for example,

with reference to FIGURE 3, valves **313** and **312** are formed when portions **112b** and **112c** are placed within pinchers of pinch valves **1007e** and **1007f**, respectively, bubble sensors **314b** and **314a** are formed when bubble sensor units **1001b**, and **1001c** are in sufficient contact with portions **112a** and **112d**, respectively, to determine the presence of bubbles therein; hemoglobin detector is formed when hemoglobin sensor **1003** is in sufficient contact with portion **112e**, and pressure sensor **317** is formed when portion **112f** is in sufficient contact with pressure sensor unit **1011** to measure the pressure of a fluid therein. With reference to FIGURE 6B, valves **316** and **613** are formed when portions **113f** and **615** are placed within pinchers of pinch valves **1007h** and **1007g**, respectively.

[0149] In operation, the assembled main instrument **810** and cassette **820** of FIGURES 9-10 can function as follows. The system can be considered to begin in an idle state or infusion mode in which the roller pump **1005** operates in a forward direction (with the impeller **1005a** turning counterclockwise as shown in FIGURE 10) to pump infusion fluid from the container **15** through the passageway **111** and the passageway **112**, toward and into the patient **P**. In this infusion mode the pump **1005** delivers infusion fluid to the patient at a suitable infusion rate as discussed elsewhere herein.

[0150] When it is time to conduct a measurement, air is first drawn into the system to clear liquid from a portion of the passageways **112**, **113**, in a manner similar to that shown in FIGURE 7B. Here, the single air injector of FIGURE 9 (extending from the junction **829** to end **615**, opposite the passageway **813**) functions in place of the manifold shown in FIGURES 7A-7J. Next, to draw a sample, the pump **1005** operates in a sample draw mode, by operating in a reverse direction and pulling a sample of bodily fluid (e.g. blood) from the patient into the passageway **112** through the connector **230**. The sample is drawn up to the hemoglobin sensor **1003**, and is preferably drawn until the output of the sensor **1003** reaches a desired plateau level indicating the presence of an undiluted blood sample in the passageway **112** adjacent the sensor **1003**.

[0151] From this point the pumps **905**, **1005**, valves **1007e**, **1007f**, **1007g**, **1007h**, bubble sensors **1001b**, **1001c** and/or hemoglobin sensor **1003** can be operated to move a series of air bubbles and sample-fluid columns into the passageway **113**, in a manner similar to that shown in FIGURES 7D-7F. The pump **905**, in place of the pump **328**, is operable by moving the piston control **907** of the pump **905** in the appropriate direction (to the left or right as shown in FIGURES 9-10) with the actuator **1009**.

[0152] Once a portion of the bodily fluid sample and any desired bubbles have moved into the passageway 113, the valve 1007h can be closed, and the remainder of the initial drawn sample or volume of bodily fluid in the passageway 112 can be returned to the patient, by operating the pump 1005 in the forward or infusion direction until the passageway 112 is again filled with infusion fluid.

[0153] With appropriate operation of the valves 1007a-1007h, and the pump(s) 905 and/or 1005, at least a portion of the bodily fluid sample in the passageway 113 (which is 10-100 microliters in volume, or 20, 30, 40, 50 or 60 microliters, in various embodiments) is moved through the sample preparation unit 332 (in the depicted embodiment a filter or membrane; alternatively a centrifuge as discussed in greater detail below). Thus, only one or more components of the bodily fluid (e.g., only the plasma of a blood sample) passes through the unit 332 or filter/membrane and enters the sample chamber or cell 903. Alternatively, where the unit 332 is omitted, the "whole" fluid moves into the sample chamber 903 for analysis.

[0154] Once the component(s) or whole fluid is in the sample chamber 903, the analysis is conducted to determine a level or concentration of one or more analytes, such as glucose, lactate, carbon dioxide, blood urea nitrogen, hemoglobin, and/or any other suitable analytes as discussed elsewhere herein. Where the analyte detection system 1700 is spectroscopic (e.g. the system 1700 of FIGURES 17 or 44-46), a spectroscopic analysis of the component(s) or whole fluid is conducted.

[0155] After the analysis, the body fluid sample within the passageway 113 is moved into the waste receptacle 325. Preferably, the pump 905 is operated via the actuator 1009 to push the body fluid, behind a column of saline or infusion fluid obtained via the passageway 909, back through the sample chamber 903 and sample preparation unit 332, and into the receptacle 325. Thus, the chamber 903 and unit 332 are back-flushed and filled with saline or infusion fluid while the bodily fluid is delivered to the waste receptacle. Following this flush a second analysis can be made on the saline or infusion fluid now in the chamber 903, to provide a "zero" or background reading. At this point, the fluid handling network of FIGURE 9, other than the waste receptacle 325, is empty of bodily fluid, and the system is ready to draw another bodily fluid sample for analysis.

[0156] In some embodiments of the apparatus 140, a pair of pinch valve pinchers acts to switch flow between one of two branches of a passageway. FIGURES 13A and 13B are front view and sectional view, respectively, of a first embodiment pinch valve

1300 in an open configuration that can direct flow either one or both of two branches, or legs, of a passageway. Pinch valve **1300** includes two separately controllable pinch valves acting on a “Y” shaped passageway **1310** to allow switch of fluid between various legs. In particular, the internal surface of passageway **1310** forms a first leg **1311** having a flexible pinch region **1312**, a second leg **1313** having a flexible pinch region **1314**, and a third leg **1315** that joins the first and second legs at an intersection **1317**. A first pair of pinch valve pinchers **1320** is positioned about pinch region **1312** and a second pair of pinch valve pinchers **1330** is positioned about pinch region **1314**. Each pair of pinch valve pinchers **1320** and **1330** is positioned on opposite sides of their corresponding pinch regions **1312**, **1314** and perpendicular to passageway **1310**, and are individually controllable by controller **210** to open and close, that is allow or prohibit fluid communication across the pinch regions. Thus, for example, when pinch valve pinchers **1320** (or **1330**) are brought sufficiently close, each part of pinch region **1312** (or **1314**) touches another part of the pinch region and fluid may not flow across the pinch region.

[0157] As an example of the use of pinch valve **1300**, FIGURE 13B shows the first and second pair of pinch valve pinchers **1320**, **1330** in an open configuration. FIGURE 13C is a sectional view showing the pair of pinch valve pinchers **1320** brought together, thus closing off a portion of first leg **1311** from the second and third legs **1313**, **1315**. In part as a result of the distance between pinchers **1320** and intersection **1317** there is a volume **1321** associated with first leg **1311** that is not isolated (“dead space”). It is preferred that dead space is minimized so that fluids of different types can be switched between the various legs of the pinch valve. In one embodiment, the dead space is reduced by placing the pinch valves close to the intersection of the legs. In another embodiment, the dead space is reduced by having passageway walls of varying thickness. Thus, for example, excess material between the pinch valves and the intersection will more effectively isolate a valved leg by displacing a portion of volume **1321**.

[0158] As an example of the use of pinch valve **1300** in sampling system **300**, pinchers **1320** and **1330** are positioned to act as valve **323** and **326**, respectively.

[0159] FIGURES 14A and 14B are various views of a second embodiment pinch valve **1400**, where FIGURE 14A is a front view and FIGURE 14B is a sectional view showing one valve in a closed position. Pinch valve **1400** differs from pinch valve **1300** in that the pairs of pinch valve pinchers **1320** and **1330** are replaced by pinchers **1420** and **1430**, respectively, that are aligned with passageway **1310**.

[0160] Alternative embodiment of pinch valves includes 2, 3, 4, or more passageway segments that meet at a common junction, with pinchers located at one or more passageways near the junction.

[0161] FIGURES 11 and 12 illustrate various embodiment of connector 230 which may also form or be attached to disposable portions of cassette 820 as one embodiment of an arterial patient connector 1100 and one embodiment a venous patient connector 1200. Connectors 1100 and 1200 may be generally similar to the embodiment illustrated in FIGURES 1-10, except as further detailed below.

[0162] As shown in FIGURE 11, arterial patient connector 1100 includes a stopcock 1101, a first tube portion 1103 having a length X, a blood sampling port 1105 to acquire blood samples for laboratory analysis, and fluid handling and analysis apparatus 140, a second tube 1107 having a length Y, and a tube connector 1109. Arterial patient connector 1100 also includes a pressure sensor unit 1102 that is generally similar to pressure sensor unit 1011, on the opposite side of sampling assembly 220. Length X is preferably from 6 inches (0.15 meters) to 50 inches (1.27 meters) or approximately 48 inches (1.2 meters) in length. Length Y is preferably from 1 inch (25 millimeters) to 20 inches (0.5 meters), or approximately 12 inches (0.3 meters) in length. As shown in FIGURE 12, venous patient connector 1200 includes a clamp 1201, injection port 1105, and tube connector 1109.

SECTION IV – SAMPLE ANALYSIS SYSTEM

[0163] In several embodiments, analysis is performed on blood plasma. For such embodiments, the blood plasma must be separated from the whole blood obtained from the patient. In general, blood plasma may be obtained from whole blood at any point in fluid handling system 10 between when the blood is drawn, for example at patient connector 110 or along passageway 113, and when it is analyzed. For systems where measurements are performed on whole blood, it may not be necessary to separate the blood at the point of or before the measurements is performed.

[0164] For illustrative purposes, this section describes several embodiments of separators and analyte detection systems which may form part of system 10. The separators discussed in the present specification can, in certain embodiments, comprise fluid component separators. As used herein, the term “fluid component separator” is a broad term and is used in its ordinary sense and includes, without limitation, any device that is operable to separate one or more components of a fluid to generate two or more unlike

substances. For example, a fluid component separator can be operable to separate a sample of whole blood into plasma and non-plasma components, and/or to separate a solid-liquid mix (e.g. a solids-contaminated liquid) into solid and liquid components. A fluid component separator need not achieve complete separation between or among the generated unlike substances. Examples of fluid component separators include filters, membranes, centrifuges, electrolytic devices, or components of any of the foregoing. Fluid component separators can be “active” in that they are operable to separate a fluid more quickly than is possible through the action of gravity on a static, “standing” fluid. Section IV.A below discloses a filter which can be used as a blood separator in certain embodiments of the apparatus disclosed herein. Section IV.B below discloses an analyte detection system which can be used in certain embodiments of the apparatus disclosed herein. Section IV.C below discloses a sample element which can be used in certain embodiments of the apparatus disclosed herein. Section IV.D below discloses a centrifuge and sample chamber which can be used in certain embodiments of the apparatus disclosed herein.

SECTION IV.A – BLOOD FILTER

[0165] Without limitation as to the scope of the present invention, one embodiment of sample preparation unit 332 is shown as a blood filter 1500, as illustrated in FIGURES 15 and 16, where FIGURE 15 is a side view of one embodiment of a filter, and FIGURE 16 is an exploded perspective view of the filter.

[0166] As shown in the embodiment of FIGURE 15, filter 1500 that includes a housing 1501 with an inlet 1503, a first outlet 1505 and a second outlet 1507. Housing 1501 contains a membrane 1509 that divides the internal volume of housing 1501 into a first volume 1502 that include inlet 1503 and first outlet 1505 and a second volume 1504. FIGURE 16 shows one embodiment of filter 1500 as including a first plate 1511 having inlet 1503 and outlet 1505, a first spacer 1513 having an opening forming first volume 1502, a second spacer 1515 having an opening forming second volume 1504, and a second plate 1517 having outlet 1507.

[0167] Filter 1500 provides for a continuous filtering of blood plasma from whole blood. Thus, for example, when a flow of whole blood is provided at inlet 1503 and a slight vacuum is applied to the second volume 1504 side of membrane 1509, the membrane filters blood cells and blood plasma passes through second outlet 1507. Preferably, there is transverse blood flow across the surface of membrane 1509 to prevent blood cells from clogging filter 1500. Accordingly, in one embodiment of the inlet 1503

and first outlet **1505** may be configured to provide the transverse flow across membrane **1509**.

[0168] In one embodiment, membrane **1509** is a thin and strong polymer film. For example, the membrane filter may be a 10 micron thick polyester or polycarbonate film. Preferably, the membrane filter has a smooth glass-like surface, and the holes are uniform, precisely sized, and clearly defined. The material of the film may be chemically inert and have low protein binding characteristics.

[0169] One way to manufacture membrane **1509** is with a Track Etching process. Preferably, the “raw” film is exposed to charged particles in a nuclear reactor, which leaves “tracks” in the film. The tracks may then be etched through the film, which results in holes that are precisely sized and uniformly cylindrical. For example, GE Osmonics, Inc. (4636 Somerton Rd. Trevose, PA 19053-6783) utilizes a similar process to manufacture a material that adequately serves as the membrane filter. The surface the membrane filter depicted above is a GE Osmonics Polycarbonate TE film.

[0170] As one example of the use of filter **1500**, the plasma from 3 cc of blood may be extracted using a polycarbonate track etch film (“PCTE”) as the membrane filter. The PCTE may have a pore size of 2 μm and an effective area of 170 millimeter². Preferably, the tubing connected to the supply, exhaust and plasma ports has an internal diameter of 1 millimeter. In one embodiment of a method employed with this configuration, 100 μl of plasma can be initially extracted from the blood. After saline is used to rinse the supply side of the cell, another 100 μl of clear plasma can be extracted. The rate of plasma extraction in this method and configuration can be about 15-25 $\mu\text{l}/\text{min}$.

[0171] Using a continuous flow mechanism to extract plasma may provide several benefits. In one preferred embodiment, the continuous flow mechanism is reusable with multiple samples, and there is negligible sample carryover to contaminate subsequent samples. One embodiment may also eliminate most situations in which plugging may occur. Additionally, a preferred configuration provides for a low internal volume.

[0172] Additional information on filters, methods of use thereof, and related technologies may be found in U.S. Patent Application Publication No. 2005/0038357, published on February 17, 2005, titled SAMPLE ELEMENT WITH BARRIER MATERIAL; and U.S. Patent Application No. 11/122,794, filed on May 5, 2005, titled SAMPLE ELEMENT WITH SEPARATOR. The entire contents of the above noted

publication and patent application are hereby incorporated by reference herein and made a part of this specification.

SECTION IV.B – ANALYTE DETECTION SYSTEM

[0173] One embodiment of analyte detection system 334, which is not meant to limit the scope of the present invention, is shown in FIGURE 17 as an optical analyte detection system 1700. Analyte detection system 1700 is adapted to measure spectra of blood plasma. The blood plasma provided to analyte detection system 334 may be provided by sample preparation unit 332, including but not limited to a filter 1500.

[0174] Analyte detection system 1700 comprises an energy source 1720 disposed along a major axis X of system 1700. When activated, the energy source 1720 generates an energy beam E which advances from the energy source 1720 along the major axis X. In one embodiment, the energy source 1720 comprises an infrared source and the energy beam E comprises an infrared energy beam.

[0175] The energy beam E passes through an optical filter 1725 also situated on the major axis X, before reaching a probe region 1710. Probe region 1710 is portion of apparatus 322 in the path of an energized beam E that is adapted to accept a material sample S. In one embodiment, as shown in FIGURE 17, probe region 1710 is adapted to accept a sample element or cuvette 1730, which supports or contains the material sample S. In one embodiment of the present invention, sample element 1730 is a portion of passageway 113, such as a tube or an optical cell. After passing through the sample element 1730 and the sample S, the energy beam E reaches a detector 1745.

[0176] As used herein, “sample element” is a broad term and is used in its ordinary sense and includes, without limitation, structures that have a sample chamber and at least one sample chamber wall, but more generally includes any of a number of structures that can hold, support or contain a material sample and that allow electromagnetic radiation to pass through a sample held, supported or contained thereby; e.g., a cuvette, test strip, etc.

[0177] In one embodiment of the present invention, sample element 1730 forms a disposable portion of cassette 820, and the remaining portions of system 1700 form portions of instrument 810, and probe region 1710 is probe region 1002.

[0178] With further reference to FIGURE 17, the detector 1745 responds to radiation incident thereon by generating an electrical signal and passing the signal to processor 210 for analysis. Based on the signal(s) passed to it by the detector 1745, the

processor computes the concentration of the analyte(s) of interest in the sample **S**, and/or the absorbance/transmittance characteristics of the sample **S** at one or more wavelengths or wavelength bands employed to analyze the sample. The processor **210** computes the concentration(s), absorbance(s), transmittance(s), etc. by executing a data processing algorithm or program instructions residing within memory **212** accessible by the processor **210**.

[0179] In the embodiment shown in FIGURE 17, the filter **1725** may comprise a varying-passband filter, to facilitate changing, over time and/or during a measurement taken with apparatus **322**, the wavelength or wavelength band of the energy beam **E** that may pass the filter **1725** for use in analyzing the sample **S**. (In various other embodiments, the filter **1725** may be omitted altogether.) Some examples of a varying-passband filter usable with apparatus **322** include, but are not limited to, a filter wheel (discussed in further detail below), an electronically tunable filter, such as those manufactured by Aegis Semiconductor (Woburn, MA), a custom filter using an "Active Thin Films platform," a Fabry-Perot interferometer, such as those manufactured by Scientific Solutions, Inc. (North Chelmsford, MA), a custom liquid crystal Fabry-Perot (LCFP) Tunable Filter, or a tunable monochromator, such as a HORIBA (Jobin Yvon, Inc. (Edison, NJ) H1034 type with 7-10 μm grating, or a custom designed system.

[0180] In one embodiment detection system **1700**, filter **1725** comprises a varying-passband filter, to facilitate changing, over time and/or during a measurement taken with the detection system **1700**, the wavelength or wavelength band of the energy beam **E** that may pass the filter **25** for use in analyzing the sample **S**. When the energy beam **E** is filtered with a varying-passband filter, the absorption/transmittance characteristics of the sample **S** can be analyzed at a number of wavelengths or wavelength bands in a separate, sequential manner. As an example, assume that it is desired to analyze the sample **S** at **N** separate wavelengths (Wavelength 1 through Wavelength **N**). The varying-passband filter is first operated or tuned to permit the energy beam **E** to pass at Wavelength 1, while substantially blocking the beam **E** at most or all other wavelengths to which the detector **1745** is sensitive (including Wavelengths 2-**N**). The absorption/transmittance properties of the sample **S** are then measured at Wavelength 1, based on the beam **E** that passes through the sample **S** and reaches the detector **1745**. The varying-passband filter is then operated or tuned to permit the energy beam **E** to pass at Wavelength 2, while substantially blocking other wavelengths as discussed above; the sample **S** is then analyzed at Wavelength 2 as

was done at Wavelength 1. This process is repeated until all of the wavelengths of interest have been employed to analyze the sample S. The collected absorption/transmittance data can then be analyzed by the processor 210 to determine the concentration of the analyte(s) of interest in the material sample S. The measured spectra of sample S is referred to herein in general as $C_s(\lambda_i)$, that is, a wavelength dependent spectra in which C_s is, for example, a transmittance, an absorbance, an optical density, or some other measure of the optical properties of sample S having values at or about a number of wavelengths λ_i , where i ranges over the number of measurements taken. The measurement $C_s(\lambda_i)$ is a linear array of measurements that is alternatively written as C_{s_i} .

[0181] The spectral region of system 1700 depends on the analysis technique and the analyte and mixtures of interest. For example, one useful spectral region for the measurement of glucose in blood using absorption spectroscopy is the mid-IR (for example, about 4 microns to about 11 microns). In one embodiment system 1700, energy source 1720 produces a beam E having an output in the range of about 4 microns to about 11 microns. Although water is the main contributor to the total absorption across this spectral region, the peaks and other structures present in the blood spectrum from about 6.8 microns to 10.5 microns are due to the absorption spectra of other blood components. The 4 to 11 micron region has been found advantageous because glucose has a strong absorption peak structure from about 8.5 to 10 microns, whereas most other blood constituents have a low and flat absorption spectrum in the 8.5 to 10 micron range. The main exceptions are water and hemoglobin, both of which are interferents in this region.

[0182] The amount of spectral detail provided by system 1700 depends on the analysis technique and the analyte and mixture of interest. For example, the measurement of glucose in blood by mid-IR absorption spectroscopy is accomplished with from 11 to 25 filters within a spectral region. In one embodiment system 1700, energy source 1720 produces a beam E having an output in the range of about 4 microns to about 11 microns, and filter 1725 include a number of narrow band filters within this range, each allowing only energy of a certain wavelength or wavelength band to pass therethrough. Thus, for example, one embodiment filter 1725 includes a filter wheel having 11 filters with a nominal wavelength approximately equal to one of the following: 3 μm , 4.06 μm , 4.6 μm , 4.9 μm , 5.25 μm , 6.12 μm , 6.47 μm , 7.98 μm , 8.35 μm , 9.65 μm , and 12.2 μm .

[0183] In one embodiment, individual infrared filters of the filter wheel are multi-cavity, narrow band dielectric stacks on germanium or sapphire substrates,

manufactured by either OCLI (JDS Uniphase, San Jose, CA) or Spectrogon US, Inc. (Parsippany, NJ). Thus, for example, each filter may nominally be 1 millimeter thick and 10 millimeter square. The peak transmission of the filter stack is typically between 50% and 70%, and the bandwidths are typically between 150 nm and 350 nm with center wavelengths between 4 and 10 μ m. Alternatively, a second blocking IR filter is also provided in front of the individual filters. The temperature sensitivity is preferably <0.01% per degree C to assist in maintaining nearly constant measurements over environmental conditions.

[0184] In one embodiment, the detection system 1700 computes an analyte concentration reading by first measuring the electromagnetic radiation detected by the detector 1745 at each center wavelength, or wavelength band, without the sample element 1730 present on the major axis X (this is known as an “air” reading). Second, the system 1700 measures the electromagnetic radiation detected by the detector 1745 for each center wavelength, or wavelength band, with the material sample S present in the sample element 1730, and the sample element and sample S in position on the major axis X (i.e., a “wet” reading). Finally, the processor 210 computes the concentration(s), absorbance(s) and/or transmittances relating to the sample S based on these compiled readings.

[0185] In one embodiment, the plurality of air and wet readings are used to generate a pathlength corrected spectrum as follows. First, the measurements are normalized to give the transmission of the sample at each wavelength. Using both a signal and reference measurement at each wavelength, and letting S_i represent the signal of detector 1745 at wavelength i and R_i represent the signal of the detector at wavelength i , the transmittance, T_i at wavelength i may be computed as $T_i = S_i(\text{wet}) / S_i(\text{air})$. Optionally, the spectra may be calculated as the optical density, OD_i , as $-\text{Log}(T_i)$. Next, the transmission over the wavelength range of approximately 4.5 μ m to approximately 5.5 μ m is analyzed to determine the pathlength. Specifically, since water is the primary absorbing species of blood over this wavelength region, and since the optical density is the product of the optical pathlength and the known absorption coefficient of water ($OD = L \sigma$, where L is the optical pathlength and σ is the absorption coefficient), any one of a number of standard curve fitting procedures may be used to determine the optical pathlength, L from the measured OD . The pathlength may then be used to determine the absorption coefficient of the sample at each wavelength. Alternatively, the optical pathlength may be used in further calculations to convert absorption coefficients to optical density.

[0186] Blood samples may be prepared and analyzed by system 1700 in a variety of configurations. In one embodiment, sample S is obtained by drawing blood, either using a syringe or as part of a blood flow system, and transferring the blood into sample chamber 903. In another embodiment, sample S is drawn into a sample container that is a sample chamber 903 adapted for insertion into system 1700.

[0187] FIGURE 44 depicts another embodiment of the analyte detection system 1700, which may be generally similar to the embodiment illustrated in FIGURE 17, except as further detailed below. Where possible, similar elements are identified with identical reference numerals in the depiction of the embodiments of FIGURES 17 and 44.

[0188] The detection system 1700 shown in FIGURE 44 includes a collimator 30 located between source 1720 and filter 1725 and a beam sampling optics 90 between the filter and sample element 1730. Filter 1725 includes a primary filter 40 and a filter wheel assembly 4420 which can insert one of a plurality of optical filters into energy beam E. System 1700 also includes a sample detector 150 may be generally similar to sample detector 1725, except as further detailed below.

[0189] As shown in FIGURE 44, energy beam E from source 1720 passes through collimator 30 through which the before reaching a primary optical filter 40 which is disposed downstream of a wide end 36 of the collimator 30. Filter 1725 is aligned with the source 1720 and collimator 30 on the major axis X and is preferably configured to operate as a broadband filter, allowing only a selected band, e.g. between about 2.5 μm and about 12.5 μm , of wavelengths emitted by the source 1720 to pass therethrough, as discussed below. In one embodiment, the energy source 1720 comprises an infrared source and the energy beam E comprises an infrared energy beam. One suitable energy source 1720 is the TOMA TECH™ IR-50 available from HawkEye Technologies of Milford, Connecticut.

[0190] With further reference to FIGURE 44, primary filter 40 is mounted in a mask 44 so that only those portions of the energy beam E which are incident on the primary filter 40 can pass the plane of the mask-primary filter assembly. The primary filter 40 is generally centered on and oriented orthogonal to the major axis X and is preferably circular (in a plane orthogonal to the major axis X) with a diameter of about 8 mm. Of course, any other suitable size or shape may be employed. As discussed above, the primary filter 40 preferably operates as a broadband filter. In the illustrated embodiment, the primary filter 40 preferably allows only energy wavelengths between about 4 μm and about 11 μm to pass therethrough. However, other ranges of wavelengths can be selected. The primary filter 40

advantageously reduces the filtering burden of secondary optical filter(s) **60** disposed downstream of the primary filter **40** and improves the rejection of electromagnetic radiation having a wavelength outside of the desired wavelength band. Additionally, the primary filter **40** can help minimize the heating of the secondary filter(s) **60** by the energy beam E passing therethrough. Despite these advantages, the primary filter **40** and/or mask **44** may be omitted in alternative embodiments of the system **1700** shown in FIGURE 44.

[0191] The primary filter **40** is preferably configured to substantially maintain its operating characteristics (center wavelength, passband width) where some or all of the energy beam E deviates from normal incidence by a cone angle of up to about twelve degrees relative to the major axis X. In further embodiments, this cone angle may be up to about 15 to 35 degrees, or from about 15 degrees or 20 degrees. The primary filter **40** may be said to “substantially maintain” its operating characteristics where any changes therein are insufficient to affect the performance or operation of the detection system **1700** in a manner that would raise significant concerns for the user(s) of the system in the context in which the system **1700** is employed.

[0192] In the embodiment illustrated in FIGURE 44, filter wheel assembly **4420** includes an optical filter wheel **50** and a stepper motor **70** connected to the filter wheel and configured to generate a force to rotate the filter wheel **50**. Additionally, a position sensor **80** is disposed over a portion of the circumference of the filter wheel **50** and may be configured to detect the angular position of the filter wheel **50** and to generate a corresponding filter wheel position signal, thereby indicating which filter is in position on the major axis X. Alternatively, the stepper motor **70** may be configured to track or count its own rotation(s), thereby tracking the angular position of the filter wheel, and pass a corresponding position signal to the processor **210**. Two suitable position sensors are models EE-SPX302-W2A and EE-SPX402-W2A available from Omron Corporation of Kyoto, Japan.

[0193] Optical filter wheel **50** is employed as a varying-passband filter, to selectively position the secondary filter(s) **60** on the major axis X and/or in the energy beam E. The filter wheel **50** can therefore selectively tune the wavelength(s) of the energy beam E downstream of the wheel **50**. These wavelength(s) vary according to the characteristics of the secondary filter(s) **60** mounted in the filter wheel **50**. The filter wheel **50** positions the secondary filter(s) **60** in the energy beam E in a “one-at-a-time” fashion to sequentially vary, as discussed above, the wavelengths or wavelength bands employed to analyze the

material sample S. An alternative to filter wheel 50 is a linear filter translated by a motor (not shown). The linear filter may be, for example, a linear array of separate filters or a single filter with filter properties that change in a linear dimension.

[0194] In alternative arrangements, the single primary filter 40 depicted in FIGURE 44 may be replaced or supplemented with additional primary filters mounted on the filter wheel 50 upstream of each of the secondary filters 60. As yet another alternative, the primary filter 40 could be implemented as a primary filter wheel (not shown) to position different primary filters on the major axis X at different times during operation of the detection system 1700, or as a tunable filter.

[0195] The filter wheel 50, in the embodiment depicted in FIGURE 45, can comprise a wheel body 52 and a plurality of secondary filters 60 disposed on the body 52, the center of each filter being equidistant from a rotational center RC of the wheel body. The filter wheel 50 is configured to rotate about an axis which is (i) parallel to the major axis X and (ii) spaced from the major axis X by an orthogonal distance approximately equal to the distance between the rotational center RC and any of the center(s) of the secondary filter(s) 60. Under this arrangement, rotation of the wheel body 52 advances each of the filters sequentially through the major axis X, so as to act upon the energy beam E. However, depending on the analyte(s) of interest or desired measurement speed, only a subset of the filters on the wheel 50 may be employed in a given measurement run. A home position notch 54 may be provided to indicate the home position of the wheel 50 to a position sensor 80.

[0196] In one embodiment, the wheel body 52 can be formed from molded plastic, with each of the secondary filters 60 having, for example a thickness of 1 mm and a 10 mm x 10 mm or a 5 mm x 5 mm square configuration. Each of the filters 60, in this embodiment of the wheel body, is axially aligned with a circular aperture of 4 mm diameter, and the aperture centers define a circle of about 1.70 inches diameter, which circle is concentric with the wheel body 52. The body 52 itself is circular, with an outside diameter of 2.00 inches.

[0197] Each of the secondary filter(s) 60 is preferably configured to operate as a narrow band filter, allowing only a selected energy wavelength or wavelength band (i.e., a filtered energy beam (Ef) to pass therethrough. As the filter wheel 50 rotates about its rotational center RC, each of the secondary filter(s) 60 is, in turn, disposed along the major axis X for a selected dwell time corresponding to each of the secondary filter(s) 60.

[0198] The “dwell time” for a given secondary filter 60 is the time interval, in an individual measurement run of the system 1700, during which both of the following conditions are true: (i) the filter is disposed on the major axis X; and (ii) the source 1720 is energized. The dwell time for a given filter may be greater than or equal to the time during which the filter is disposed on the major axis X during an individual measurement run. In one embodiment of the analyte detection system 1700, the dwell time corresponding to each of the secondary filter(s) 60 is less than about 1 second. However, the secondary filter(s) 60 can have other dwell times, and each of the filter(s) 60 may have a different dwell time during a given measurement run.

[0199] From the secondary filter 60, the filtered energy beam (Ef) passes through a beam sampling optics 90, which includes a beam splitter 4400 disposed along the major axis X and having a face 4400a disposed at an included angle θ relative to the major axis X. The splitter 4400 preferably separates the filtered energy beam (Ef) into a sample beam (Es) and a reference beam (Er).

[0200] With further reference to FIGURE 44, the sample beam (Es) passes next through a first lens 4410 aligned with the splitter 4400 along the major axis X. The first lens 4410 is configured to focus the sample beam (Es) generally along the axis X onto the material sample S. The sample S is preferably disposed in a sample element 1730 between a first window 122 and a second window 124 of the sample element 1730. The sample element 1730 is further preferably removably disposed in a holder 4430, and the holder 4430 has a first opening 132 and a second opening 134 configured for alignment with the first window 122 and second window 124, respectively. Alternatively, the sample element 1730 and sample S may be disposed on the major axis X without use of the holder 4430.

[0201] At least a fraction of the sample beam (Es) is transmitted through the sample S and continues onto a second lens 4440 disposed along the major axis X. The second lens 4440 is configured to focus the sample beam (Es) onto a sample detector 150, thus increasing the flux density of the sample beam (Es) incident upon the sample detector 150. The sample detector 150 is configured to generate a signal corresponding to the detected sample beam (Es) and to pass the signal to a processor 210, as discussed in more detail below.

[0202] Beam sampling optics 90 further includes a third lens 160 and a reference detector 170. The reference beam (Er) is directed by beam sampling optics 90 from the beam splitter 4400 to a third lens 160 disposed along a minor axis Y generally

orthogonal to the major axis X. The third lens **160** is configured to focus the reference beam (Er) onto reference detector **170**, thus increasing the flux density of the reference beam (Er) incident upon the reference detector **170**. In one embodiment, the lenses **4410**, **4440**, **160** may be formed from a material which is highly transmissive of infrared radiation, for example germanium or silicon. In addition, any of the lenses **4410**, **4440** and **160** may be implemented as a system of lenses, depending on the desired optical performance. The reference detector **170** is also configured to generate a signal corresponding to the detected reference beam (Er) and to pass the signal to the processor **210**, as discussed in more detail below. Except as noted below, the sample and reference detectors **150**, **170** may be generally similar to the detector **1745** illustrated in FIGURE 17. Based on signals received from the sample and reference detectors **150**, **170**, the processor **210** computes the concentration(s), absorbance(s), transmittance(s), etc. relating to the sample S by executing a data processing algorithm or program instructions residing within the memory **212** accessible by the processor **210**.

[0203] In further variations of the detection system **1700** depicted in FIGURE 44, beam sampling optics **90**, including the beam splitter **4400**, reference detector **170** and other structures on the minor axis Y may be omitted, especially where the output intensity of the source **1720** is sufficiently stable to obviate any need to reference the source intensity in operation of the detection system **1700**. Thus, for example, sufficient signals may be generated by detectors **170** and **150** with one or more of lenses **4410**, **4440**, **160** omitted. Furthermore, in any of the embodiments of the analyte detection system **1700** disclosed herein, the processor **210** and/or memory **212** may reside partially or wholly in a standard personal computer ("PC") coupled to the detection system **1700**.

[0204] FIGURE 46 depicts a partial cross-sectional view of another embodiment of an analyte detection system **1700**, which may be generally similar to any of the embodiments illustrated in FIGURES 17, 44, and 45, except as further detailed below. Where possible, similar elements are identified with identical reference numerals in the depiction of the embodiments of FIGURES 17, 44, and 45.

[0205] The energy source **1720** of the embodiment of FIGURE 46 preferably comprises an emitter area **22** which is substantially centered on the major axis X. In one embodiment, the emitter area **22** may be square in shape. However the emitter area **22** can have other suitable shapes, such as rectangular, circular, elliptical, etc. One suitable emitter

area **22** is a square of about 1.5 mm on a side; of course, any other suitable shape or dimensions may be employed.

[0206] The energy source **1720** is preferably configured to selectably operate at a modulation frequency between about 1 Hz and 30 Hz and have a peak operating temperature of between about 1070 degrees Kelvin and 1170 degrees Kelvin. Additionally, the source **1720** preferably operates with a modulation depth greater than about 80% at all modulation frequencies. The energy source **1720** preferably emits electromagnetic radiation in any of a number of spectral ranges, e.g., within infrared wavelengths; in the mid-infrared wavelengths; above about 0.8 μm ; between about 5.0 μm and about 20.0 μm ; and/or between about 5.25 μm and about 12.0 μm . However, in other embodiments, the detection system **1700** may employ an energy source **1720** which is unmodulated and/or which emits in wavelengths found anywhere from the visible spectrum through the microwave spectrum, for example anywhere from about 0.4 μm to greater than about 100 μm . In still other embodiments, the energy source **1720** can emit electromagnetic radiation in wavelengths between about 3.5 μm and about 14 μm , or between about 0.8 μm and about 2.5 μm , or between about 2.5 μm and 20 μm , or between about 20 μm and about 100 μm , or between about 6.85 μm and about 10.10 μm . In yet other embodiments, the energy source **1720** can emit electromagnetic radiation within the radio frequency (RF) range or the terahertz range. All of the above-recited operating characteristics are merely exemplary, and the source **1720** may have any operating characteristics suitable for use with the analyte detection system **1700**.

[0207] A power supply (not shown) for the energy source **1720** is preferably configured to selectably operate with a duty cycle of between about 30% and about 70%. Additionally, the power supply is preferably configured to selectably operate at a modulation frequency of about 10Hz, or between about 1 Hz and about 30 Hz. The operation of the power supply can be in the form of a square wave, a sine wave, or any other waveform defined by a user.

[0208] With further reference to FIGURE 46, the collimator **30** comprises a tube **30a** with one or more highly-reflective inner surfaces **32** which diverge from a relatively narrow upstream end **34** to a relatively wide downstream end **36** as they extend downstream, away from the energy source **1720**. The narrow end **34** defines an upstream aperture **34a** which is situated adjacent the emitter area **22** and permits radiation generated by the emitter area to propagate downstream into the collimator. The wide end **36** defines a

downstream aperture **36a**. Like the emitter area **22**, each of the inner surface(s) **32**, upstream aperture **34a** and downstream aperture **36a** is preferably substantially centered on the major axis X.

[0209] As illustrated in FIGURE 46, the inner surface(s) **32** of the collimator may have a generally curved shape, such as a parabolic, hyperbolic, elliptical or spherical shape. One suitable collimator **30** is a compound parabolic concentrator (CPC). In one embodiment, the collimator **30** can be up to about 20 mm in length. In another embodiment, the collimator **30** can be up to about 30 mm in length. However, the collimator **30** can have any length, and the inner surface(s) **32** may have any shape, suitable for use with the analyte detection system **1700**.

[0210] The inner surfaces **32** of the collimator **30** cause the rays making up the energy beam E to straighten (i.e., propagate at angles increasingly parallel to the major axis X) as the beam E advances downstream, so that the energy beam E becomes increasingly or substantially cylindrical and oriented substantially parallel to the major axis X. Accordingly, the inner surfaces **32** are highly reflective and minimally absorptive in the wavelengths of interest, such as infrared wavelengths.

[0211] The tube **30a** itself may be fabricated from a rigid material such as aluminum, steel, or any other suitable material, as long as the inner surfaces **32** are coated or otherwise treated to be highly reflective in the wavelengths of interest. For example, a polished gold coating may be employed. Preferably, the inner surface(s) **32** of the collimator **30** define a circular cross-section when viewed orthogonal to the major axis X; however, other cross-sectional shapes, such as a square or other polygonal shapes, parabolic or elliptical shapes may be employed in alternative embodiments.

[0212] As noted above, the filter wheel **50** shown in FIGURE 46 comprises a plurality of secondary filters **60** which preferably operate as narrow band filters, each filter allowing only energy of a certain wavelength or wavelength band to pass therethrough. In one configuration suitable for detection of glucose in a sample S, the filter wheel **50** comprises twenty or twenty-two secondary filters **60**, each of which is configured to allow a filtered energy beam (E_f) to travel therethrough with a nominal wavelength approximately equal to one of the following: 3 μm, 4.06 μm, 4.6 μm, 4.9 μm, 5.25 μm, 6.12 μm, 6.47 μm, 7.98 μm, 8.35 μm, 9.65 μm, and 12.2 μm. (Moreover, this set of wavelengths may be employed with or in any of the embodiments of the analyte detection system **1700** disclosed herein.) Each secondary filter's **60** center wavelength is preferably equal to the desired

nominal wavelength plus or minus about 2%. Additionally, the secondary filters 60 are preferably configured to have a bandwidth of about 0.2 μm , or alternatively equal to the nominal wavelength plus or minus about 2%-10%.

[0213] In another embodiment, the filter wheel 50 comprises twenty secondary filters 60, each of which is configured to allow a filtered energy beam (Ef) to travel therethrough with a nominal center wavelengths of: 4.275 μm , 4.5 μm , 4.7 μm , 5.0 μm , 5.3 μm , 6.056 μm , 7.15 μm , 7.3 μm , 7.55 μm , 7.67 μm , 8.06 μm , 8.4 μm , 8.56 μm , 8.87 μm , 9.15 μm , 9.27 μm , 9.48 μm , 9.68 μm , 9.82 μm , and 10.06 μm . (This set of wavelengths may also be employed with or in any of the embodiments of the analyte detection system 1700 disclosed herein.) In still another embodiment, the secondary filters 60 may conform to any one or combination of the following specifications: center wavelength tolerance of $\pm 0.01 \mu\text{m}$; half-power bandwidth tolerance of $\pm 0.01 \mu\text{m}$; peak transmission greater than or equal to 75%; cut-on/cut-off slope less than 2%; center-wavelength temperature coefficient less than .01% per degree Celsius; out of band attenuation greater than OD 5 from 3 μm to 12 μm ; flatness less than 1.0 waves at 0.6328 μm ; surface quality of E-E per Mil-F-48616; and overall thickness of about 1 mm.

[0214] In still another embodiment, the secondary filters mentioned above may conform to any one or combination of the following half-power bandwidth ("HPBW") specifications:

Center Wavelength (μm)	HPBW (μm)	Center Wavelength (μm)	HPBW (μm)
4.275	0.05	8.06	0.3
4.5	0.18	8.4	0.2
4.7	0.13	8.56	0.18
5.0	0.1	8.87	0.2
5.3	0.13	9.15	0.15
6.056	0.135	9.27	0.14
7.15	0.19	9.48	0.23
7.3	0.19	9.68	0.3
7.55	0.18	9.82	0.34
7.67	0.197	10.06	0.2

[0215] In still further embodiments, the secondary filters may have a center wavelength tolerance of $\pm 0.5 \%$ and a half-power bandwidth tolerance of $\pm 0.02 \mu\text{m}$.

[0216] Of course, the number of secondary filters employed, and the center wavelengths and other characteristics thereof, may vary in further embodiments of the system 1700, whether such further embodiments are employed to detect glucose, or other analytes instead of or in addition to glucose. For example, in another embodiment, the filter wheel 50 can have fewer than fifty secondary filters 60. In still another embodiment, the filter wheel 50 can have fewer than twenty secondary filters 60. In yet another embodiment, the filter wheel 50 can have fewer than ten secondary filters 60.

[0217] In one embodiment, the secondary filters 60 each measure about 10 mm long by 10 mm wide in a plane orthogonal to the major axis X, with a thickness of about 1 mm. However, the secondary filters 60 can have any other (e.g., smaller) dimensions suitable for operation of the analyte detection system 1700. Additionally, the secondary filters 60 are preferably configured to operate at a temperature of between about 5 °C and about 35 °C and to allow transmission of more than about 75% of the energy beam E therethrough in the wavelength(s) which the filter is configured to pass.

[0218] According to the embodiment illustrated in FIGURE 46, the primary filter 40 operates as a broadband filter and the secondary filters 60 disposed on the filter wheel 50 operate as narrow band filters. However, one of ordinary skill in the art will realize that other structures can be used to filter energy wavelengths according to the embodiments described herein. For example, the primary filter 40 may be omitted and/or an electronically tunable filter or Fabry-Perot interferometer (not shown) can be used in place of the filter wheel 50 and secondary filters 60. Such a tunable filter or interferometer can be configured to permit, in a sequential, "one-at-a-time" fashion, each of a set of wavelengths or wavelength bands of electromagnetic radiation to pass therethrough for use in analyzing the material sample S.

[0219] A reflector tube 98 is preferably positioned to receive the filtered energy beam (E_f) as it advances from the secondary filter(s) 60. The reflector tube 98 is preferably secured with respect to the secondary filter(s) 60 to substantially prevent introduction of stray electromagnetic radiation, such as stray light, into the reflector tube 98 from outside of the detection system 1700. The inner surfaces of the reflector tube 98 are highly reflective in the relevant wavelengths and preferably have a cylindrical shape with a generally circular cross-section orthogonal to the major and/or minor axis X, Y. However, the inner surface of the tube 98 can have a cross-section of any suitable shape, such as oval, square, rectangular, etc. Like the collimator 30, the reflector tube 98 may be formed from a rigid material such

as aluminum, steel, etc., as long as the inner surfaces are coated or otherwise treated to be highly reflective in the wavelengths of interest. For example, a polished gold coating may be employed.

[0220] According to the embodiment illustrated in FIGURE 46, the reflector tube **98** preferably comprises a major section **98a** and a minor section **98b**. As depicted, the reflector tube **98** can be T-shaped with the major section **98a** having a greater length than the minor section **98b**. In another example, the major section **98a** and the minor section **98b** can have the same length. The major section **98a** extends between a first end **98c** and a second end **98d** along the major axis X. The minor section **98b** extends between the major section **98a** and a third end **98e** along the minor axis Y.

[0221] The major section **98a** conducts the filtered energy beam (Ef) from the first end **98c** to the beam splitter **4400**, which is housed in the major section **98a** at the intersection of the major and minor axes X, Y. The major section **98a** also conducts the sample beam (Es) from the beam splitter **4400**, through the first lens **4410** and to the second end **98d**. From the second end **98d** the sample beam (Es) proceeds through the sample element **1730**, holder **4430** and second lens **4440**, and to the sample detector **150**. Similarly, the minor section **98b** conducts the reference beam (Er) through beam sampling optics **90** from the beam splitter **4400**, through the third lens **160** and to the third end **98e**. From the third end **98e** the reference beam (Er) proceeds to the reference detector **170**.

[0222] The sample beam (Es) preferably comprises from about 75% to about 85% of the energy of the filtered energy beam (Ef). More preferably, the sample beam (Es) comprises about 80% of the energy of the filtered energy beam (Es). The reference beam (Er) preferably comprises from about 10% and about 50% of the energy of the filtered energy beam (Es). More preferably, the reference beam (Er) comprises about 20% of the energy of the filtered energy beam (Ef). Of course, the sample and reference beams may take on any suitable proportions of the energy beam E.

[0223] The reflector tube **98** also houses the first lens **4410** and the third lens **160**. As illustrated in FIGURE 46, the reflector tube **98** houses the first lens **4410** between the beam splitter **4400** and the second end **98d**. The first lens **4410** is preferably disposed so that a plane **4612** of the lens **4410** is generally orthogonal to the major axis X. Similarly, the tube **98** houses the third lens **160** between the beam splitter **4400** and the third end **98e**. The third lens **160** is preferably disposed so that a plane **162** of the third lens **160** is generally orthogonal to the minor axis Y. The first lens **4410** and the third lens **160** each has a focal

length configured to substantially focus the sample beam (Es) and reference beam (Er), respectively, as the beams (Es, Er) pass through the lenses **4410**, **160**. In particular, the first lens **4410** is configured, and disposed relative to the holder **4430**, to focus the sample beam (Es) so that substantially the entire sample beam (Es) passes through the material sample S, residing in the sample element **1730**. Likewise, the third lens **160** is configured to focus the reference beam (Er) so that substantially the entire reference beam (Er) impinges onto the reference detector **170**.

[0224] The sample element **1730** is retained within the holder **4430**, which is preferably oriented along a plane generally orthogonal to the major axis X. The holder **4430** is configured to be slidably displaced between a loading position and a measurement position within the analyte detection system **1700**. In the measurement position, the holder **4430** contacts a stop edge 136 which is located to orient the sample element **1730** and the sample S contained therein on the major axis X.

[0225] The structural details of the holder **4430** depicted in FIGURE 46 are unimportant, so long as the holder positions the sample element **1730** and sample S on and substantially orthogonal to the major axis X, while permitting the energy beam E to pass through the sample element and sample. As with the embodiment depicted in FIGURE 44, the holder **4430** may be omitted and the sample element **1730** positioned alone in the depicted location on the major axis X. However, the holder **4430** is useful where the sample element **1730** (discussed in further detail below) is constructed from a highly brittle or fragile material, such as barium fluoride, or is manufactured to be extremely thin.

[0226] As with the embodiment depicted in FIGURE 44, the sample and reference detectors **150**, **170** shown in FIGURE 46 respond to radiation incident thereon by generating signals and passing them to the processor **210**. Based these signals received from the sample and reference detectors **150**, **170**, the processor **210** computes the concentration(s), absorbance(s), transmittance(s), etc. relating to the sample S by executing a data processing algorithm or program instructions residing within the memory **212** accessible by the processor **210**. In further variations of the detection system **1700** depicted in FIGURE 46, the beam splitter **4400**, reference detector **170** and other structures on the minor axis Y may be omitted, especially where the output intensity of the source **1720** is sufficiently stable to obviate any need to reference the source intensity in operation of the detection system **1700**.

[0227] FIGURE 47 depicts a sectional view of the sample detector 150 in accordance with one embodiment. Sample detector 150 is mounted in a detector housing 152 having a receiving portion 152a and a cover 152b. However, any suitable structure may be used as the sample detector 150 and housing 152. The receiving portion 152a preferably defines an aperture 152c and a lens chamber 152d, which are generally aligned with the major axis X when the housing 152 is mounted in the analyte detection system 1700. The aperture 152c is configured to allow at least a fraction of the sample beam (Es) passing through the sample S and the sample element 1730 to advance through the aperture 152c and into the lens chamber 152d.

[0228] The receiving portion 152a houses the second lens 4440 in the lens chamber 152d proximal to the aperture 152c. The sample detector 150 is also disposed in the lens chamber 152d downstream of the second lens 4440 such that a detection plane 154 of the detector 150 is substantially orthogonal to the major axis X. The second lens 4440 is positioned such that a plane 142 of the lens 4440 is substantially orthogonal to the major axis X. The second lens 4440 is configured, and is preferably disposed relative to the holder 4430 and the sample detector 150, to focus substantially all of the sample beam (Es) onto the detection plane 154, thereby increasing the flux density of the sample beam (Es) incident upon the detection plane 154.

[0229] With further reference to FIGURE 47, a support member 156 preferably holds the sample detector 150 in place in the receiving portion 152a. In the illustrated embodiment, the support member 156 is a spring 156 disposed between the sample detector 150 and the cover 152b. The spring 156 is configured to maintain the detection plane 154 of the sample detector 150 substantially orthogonal to the major axis X. A gasket 157 is preferably disposed between the cover 152b and the receiving portion 152a and surrounds the support member 156.

[0230] The receiving portion 152a preferably also houses a printed circuit board 158 disposed between the gasket 157 and the sample detector 150. The board 158 connects to the sample detector 150 through at least one connecting member 150a. The sample detector 150 is configured to generate a detection signal corresponding to the sample beam (Es) incident on the detection plane 154. The sample detector 150 communicates the detection signal to the circuit board 158 through the connecting member 150a, and the board 158 transmits the detection signal to the processor 210.

[0231] In one embodiment, the sample detector **150** comprises a generally cylindrical housing **150a**, e.g. a type TO-39 “metal can” package, which defines a generally circular housing aperture **150b** at its “upstream” end. In one embodiment, the housing **150a** has a diameter of about 0.323 inches and a depth of about 0.248 inches, and the aperture **150b** may have a diameter of about 0.197 inches.

[0232] A detector window **150c** is disposed adjacent the aperture **150b**, with its upstream surface preferably about 0.078 inches (+/- 0.004 inches) from the detection plane **154**. (The detection plane **154** is located about 0.088 inches (+/- 0.004 inches) from the upstream edge of the housing **150a**, where the housing has a thickness of about 0.010 inches.) The detector window **150c** is preferably transmissive of infrared energy in at least a 3-12 micron passband; accordingly, one suitable material for the window **150c** is germanium. The endpoints of the passband may be “spread” further to less than 2.5 microns, and/or greater than 12.5 microns, to avoid unnecessary absorbance in the wavelengths of interest. Preferably, the transmittance of the detector window **150c** does not vary by more than 2% across its passband. The window **150c** is preferably about 0.020 inches in thickness. The sample detector **150** preferably substantially retains its operating characteristics across a temperature range of -20 to +60 degrees Celsius.

[0233] FIGURE 48 depicts a sectional view of the reference detector **170** in accordance with one embodiment. The reference detector **170** is mounted in a detector housing **172** having a receiving portion **172a** and a cover **172b**. However, any suitable structure may be used as the sample detector **150** and housing **152**. The receiving portion **172a** preferably defines an aperture **172c** and a chamber **172d** which are generally aligned with the minor axis Y, when the housing **172** is mounted in the analyte detection system **1700**. The aperture **172c** is configured to allow the reference beam (Er) to advance through the aperture **172c** and into the chamber **172d**.

[0234] The receiving portion **172a** houses the reference detector **170** in the chamber **172d** proximal to the aperture **172c**. The reference detector **170** is disposed in the chamber **172d** such that a detection plane **174** of the reference detector **170** is substantially orthogonal to the minor axis Y. The third lens **160** is configured to substantially focus the reference beam (Er) so that substantially the entire reference beam (Er) impinges onto the detection plane **174**, thus increasing the flux density of the reference beam (Er) incident upon the detection plane **174**.

[0235] With further reference to FIGURE 48, a support member 176 preferably holds the reference detector 170 in place in the receiving portion 172a. In the illustrated embodiment, the support member 176 is a spring 176 disposed between the reference detector 170 and the cover 172b. The spring 176 is configured to maintain the detection plane 174 of the reference detector 170 substantially orthogonal to the minor axis Y. A gasket 177 is preferably disposed between the cover 172b and the receiving portion 172a and surrounds the support member 176.

[0236] The receiving portion 172a preferably also houses a printed circuit board 178 disposed between the gasket 177 and the reference detector 170. The board 178 connects to the reference detector 170 through at least one connecting member 170a. The reference detector 170 is configured to generate a detection signal corresponding to the reference beam (E_r) incident on the detection plane 174. The reference detector 170 communicates the detection signal to the circuit board 178 through the connecting member 170a, and the board 178 transmits the detection signal to the processor 210.

[0237] In one embodiment, the construction of the reference detector 170 is generally similar to that described above with regard to the sample detector 150.

[0238] In one embodiment, the sample and reference detectors 150, 170 are both configured to detect electromagnetic radiation in a spectral wavelength range of between about 0.8 μm and about 25 μm . However, any suitable subset of the foregoing set of wavelengths can be selected. In another embodiment, the detectors 150, 170 are configured to detect electromagnetic radiation in the wavelength range of between about 4 μm and about 12 μm . The detection planes 154, 174 of the detectors 150, 170 may each define an active area about 2 mm by 2 mm or from about 1 mm by 1 mm to about 5 mm by 5 mm; of course, any other suitable dimensions and proportions may be employed. Additionally, the detectors 150, 170 may be configured to detect electromagnetic radiation directed thereto within a cone angle of about 45 degrees from the major axis X.

[0239] In one embodiment, the sample and reference detector subsystems 150, 170 may further comprise a system (not shown) for regulating the temperature of the detectors. Such a temperature-regulation system may comprise a suitable electrical heat source, thermistor, and a proportional-plus-integral-plus-derivative (PID) control. These components may be used to regulate the temperature of the detectors 150, 170 at about 35 °C. The detectors 150, 170 can also optionally be operated at other desired temperatures. Additionally, the PID control preferably has a control rate of about 60 Hz and, along with

the heat source and thermistor, maintains the temperature of the detectors **150**, **170** within about 0.1 °C of the desired temperature.

[0240] The detectors **150**, **170** can operate in either a voltage mode or a current mode, wherein either mode of operation preferably includes the use of a pre-amp module. Suitable voltage mode detectors for use with the analyte detection system **1700** disclosed herein include: models LIE 302 and 312 by InfraTec of Dresden, Germany; model L2002 by BAE Systems of Rockville, Maryland; and model LTS-1 by Dias of Dresden, Germany. Suitable current mode detectors include: InfraTec models LIE 301, 315, 345 and 355; and 2x2 current-mode detectors available from Dias.

[0241] In one embodiment, one or both of the detectors **150**, **170** may meet the following specifications, when assuming an incident radiation intensity of about 9.26×10^{-4} watts (rms) per cm^2 , at 10 Hz modulation and within a cone angle of about 15 degrees: detector area of 0.040 cm^2 (2 mm x 2 mm square); detector input of 3.70×10^{-5} watts (rms) at 10 Hz; detector sensitivity of 360 volts per watt at 10 Hz; detector output of 1.333×10^{-2} volts (rms) at 10 Hz; noise of 8.00×10^{-8} volts/sqrtHz at 10 Hz; and signal-to-noise ratios of 1.67×10^5 rms/sqrtHz and 104.4 dB/sqrtHz; and detectivity of 1.00×10^9 cm sqrtHz/watt.

[0242] In alternative embodiments, the detectors **150**, **170** may comprise microphones and/or other sensors suitable for operation of the detection system **1700** in a photoacoustic mode.

[0243] The components of any of the embodiments of the analyte detection system **1700** may be partially or completely contained in an enclosure or casing (not shown) to prevent stray electromagnetic radiation, such as stray light, from contaminating the energy beam E. Any suitable casing may be used. Similarly, the components of the detection system **1700** may be mounted on any suitable frame or chassis (not shown) to maintain their operative alignment as depicted in FIGURES 17, 44, and 46. The frame and the casing may be formed together as a single unit, member or collection of members.

[0244] In one method of operation, the analyte detection system **1700** shown in FIGURES 44 or 46 measures the concentration of one or more analytes in the material sample S, in part, by comparing the electromagnetic radiation detected by the sample and reference detectors **150**, **170**. During operation of the detection system **1700**, each of the secondary filter(s) **60** is sequentially aligned with the major axis X for a dwell time corresponding to the secondary filter **60**. (Of course, where an electronically tunable filter or Fabry-Perot interferometer is used in place of the filter wheel **50**, the tunable filter or

interferometer is sequentially tuned to each of a set of desired wavelengths or wavelength bands in lieu of the sequential alignment of each of the secondary filters with the major axis X.) The energy source 1720 is then operated at (any) modulation frequency, as discussed above, during the dwell time period. The dwell time may be different for each secondary filter 60 (or each wavelength or band to which the tunable filter or interferometer is tuned). In one embodiment of the detection system 1700, the dwell time for each secondary filter 60 is less than about 1 second. Use of a dwell time specific to each secondary filter 60 advantageously allows the detection system 1700 to operate for a longer period of time at wavelengths where errors can have a greater effect on the computation of the analyte concentration in the material sample S. Correspondingly, the detection system 1700 can operate for a shorter period of time at wavelengths where errors have less effect on the computed analyte concentration. The dwell times may otherwise be nonuniform among the filters/wavelengths/bands employed in the detection system.

[0245] For each secondary filter 60 selectively aligned with the major axis X, the sample detector 150 detects the portion of the sample beam (E_s), at the wavelength or wavelength band corresponding to the secondary filter 60, that is transmitted through the material sample S. The sample detector 150 generates a detection signal corresponding to the detected electromagnetic radiation and passes the signal to the processor 210. Simultaneously, the reference detector 170 detects the reference beam (E_r) transmitted at the wavelength or wavelength band corresponding to the secondary filter 60. The reference detector 170 generates a detection signal corresponding to the detected electromagnetic radiation and passes the signal to the processor 210. Based on the signals passed to it by the detectors 150, 170, the processor 210 computes the concentration of the analyte(s) of interest in the sample S, and/or the absorbance/transmittance characteristics of the sample S at one or more wavelengths or wavelength bands employed to analyze the sample. The processor 210 computes the concentration(s), absorbance(s), transmittance(s), etc. by executing a data processing algorithm or program instructions residing within the memory 212 accessible by the processor 210.

[0246] The signal generated by the reference detector may be used to monitor fluctuations in the intensity of the energy beam emitted by the source 1720, which fluctuations often arise due to drift effects, aging, wear or other imperfections in the source itself. This enables the processor 210 to identify changes in intensity of the sample beam (E_s) that are attributable to changes in the emission intensity of the source 1720, and not to

the composition of the sample S. By so doing, a potential source of error in computations of concentration, absorbance, etc. is minimized or eliminated.

[0247] In one embodiment, the detection system 1700 computes an analyte concentration reading by first measuring the electromagnetic radiation detected by the detectors 150, 170 at each center wavelength, or wavelength band, without the sample element 1730 present on the major axis X (this is known as an “air” reading). Second, the system 1700 measures the electromagnetic radiation detected by the detectors 150, 170 for each center wavelength, or wavelength band, with the material sample S present in the sample element 1730, and the sample element 1730 and sample S in position on the major axis X (i.e., a “wet” reading). Finally, the processor 180 computes the concentration(s), absorbance(s) and/or transmittance(s) relating to the sample S based on these compiled readings.

[0248] In one embodiment, the plurality of air and wet readings are used to generate a pathlength corrected spectrum as follows. First, the measurements are normalized to give the transmission of the sample at each wavelength. Using both a signal and reference measurement at each wavelength, and letting S_i represent the signal of detector 150 at wavelength i and R_i represent the signal of detector 170 at wavelength i , the transmission, τ_i is computed as $\tau_i = S_i(\text{wet})/R_i(\text{wet}) / S_i(\text{air})/R_i(\text{air})$. Optionally, the spectra may be calculated as the optical density, OD_i , as $-\text{Log}(T_i)$.

[0249] Next, the transmission over the wavelength range of approximately 4.5 μm to approximately 5.5 μm is analyzed to determine the pathlength. Specifically, since water is the primary absorbing species of blood over this wavelength region, and since the optical density is the product of the optical pathlength and the known absorption coefficient of water ($OD = L \sigma$, where L is the optical pathlength and σ is the absorption coefficient), any one of a number of standard curve fitting procedures may be used to determine the optical pathlength, L from the measured OD . The pathlength may then be used to determine the absorption coefficient of the sample at each wavelength. Alternatively, the optical pathlength may be used in further calculations to convert absorption coefficients to optical density.

[0250] Additional information on analyte detection systems, methods of use thereof, and related technologies may be found in the above-mentioned and incorporated U.S. Patent Application Publication No. 2005/0038357, published on February 17, 2005, titled SAMPLE ELEMENT WITH BARRIER MATERIAL.

SECTION IV.C – SAMPLE ELEMENT

[0251] FIGURE 18 is a top view of a sample element 1730, FIGURE 19 is a side view of the sample element, and FIGURE 20 is an exploded perspective view of the sample element. In one embodiment of the present invention, sample element 1730 includes sample chamber 903 that is in fluid communication with and accepts filtered blood from sample preparation unit 332. The sample element 1730 comprises a sample chamber 903 defined by sample chamber walls 1802. The sample chamber 903 is configured to hold a material sample which may be drawn from a patient, for analysis by the detection system with which the sample element 1730 is employed.

[0252] In the embodiment illustrated in FIGURES 18-19, the sample chamber 903 is defined by first and second lateral chamber walls 1802a, 1802b and upper and lower chamber walls 1802c, 1802d; however, any suitable number and configuration of chamber walls may be employed. At least one of the upper and lower chamber walls 1802c, 1802d is formed from a material which is sufficiently transmissive of the wavelength(s) of electromagnetic radiation that are employed by the sample analysis apparatus 322 (or any other system with which the sample element is to be used). A chamber wall which is so transmissive may thus be termed a “window;” in one embodiment, the upper and lower chamber walls 1802c, 1802d comprise first and second windows so as to permit the relevant wavelength(s) of electromagnetic radiation to pass through the sample chamber 903. In another embodiment, only one of the upper and lower chamber walls 1802c, 1802d comprises a window; in such an embodiment, the other of the upper and lower chamber walls may comprise a reflective surface configured to back-reflect any electromagnetic energy emitted into the sample chamber 903 by the analyte detection system with which the sample element 1730 is employed. Accordingly, this embodiment is well suited for use with an analyte detection system in which a source and a detector of electromagnetic energy are located on the same side as the sample element.

[0253] In various embodiments, the material that makes up the window(s) of the sample element 1730 is completely transmissive, i.e., it does not absorb any of the electromagnetic radiation from the source 1720 and filters 1725 that is incident upon it. In another embodiment, the material of the window(s) has some absorption in the electromagnetic range of interest, but its absorption is negligible. In yet another embodiment, the absorption of the material of the window(s) is not negligible, but it is stable for a relatively long period of time. In another embodiment, the absorption of the

window(s) is stable for only a relatively short period of time, but sample analysis apparatus 322 is configured to observe the absorption of the material and eliminate it from the analyte measurement before the material properties can change measurably. Materials suitable for forming the window(s) of the sample element 1730 include, but are not limited to, calcium fluoride, barium fluoride, germanium, silicon, polypropylene, polyethylene, or any polymer with suitable transmissivity (i.e., transmittance per unit thickness) in the relevant wavelength(s). Where the window(s) are formed from a polymer, the selected polymer can be isotactic, atactic or syndiotactic in structure, so as to enhance the flow of the sample between the window(s). One type of polyethylene suitable for constructing the sample element 1730 is type 220, extruded or blow molded, available from KUBE Ltd. of Staefa, Switzerland.

[0254] In one embodiment, the sample element 1730 is configured to allow sufficient transmission of electromagnetic energy having a wavelength of between about 4 μm and about 10.5 μm through the window(s) thereof. However, the sample element 1730 can be configured to allow transmission of wavelengths in any spectral range emitted by the energy source 1720. In another embodiment, the sample element 1730 is configured to receive an optical power of more than about 1.0 MW/cm² from the sample beam (Es) incident thereon for any electromagnetic radiation wavelength transmitted through the filter 1725. Preferably, the sample chamber 903 of the sample element 1730 is configured to allow a sample beam (Es) advancing toward the material sample S within a cone angle of 45 degrees from the major axis X (see FIGURE 17) to pass therethrough.

[0255] In the embodiment illustrated in FIGURES 18-19, the sample element further comprises a supply passage 1804 extending from the sample chamber 903 to a supply opening 1806 and a vent passage 1808 extending from the sample chamber 903 to a vent opening 1810. While the vent and supply openings 1806, 1810 are shown at one end of the sample element 1730, in other embodiments the openings may be positioned on other sides of the sample element 1730, so long as it is in fluid communication with the passages 1804 and 1808, respectively.

[0256] In operation, the supply opening 1806 of the sample element 1730 is placed in contact with the material sample S, such as a fluid flowing from a patient. The fluid is then transported through the sample supply passage 1804 and into the sample chamber 903 via an external pump or by capillary action.

[0257] Where the upper and lower chamber walls **1802c**, **1802d** comprise windows, the distance T (measured along an axis substantially orthogonal to the sample chamber **903** and/or windows **1802a**, **1802b**, or, alternatively, measured along an axis of an energy beam (such as but not limited to the energy beam E discussed above) passed through the sample chamber **903**) between them comprises an optical pathlength. In various embodiments, the pathlength is between about 1 μm and about 300 μm , between about 1 μm and about 100 μm , between about 25 μm and about 40 μm , between about 10 μm and about 40 μm , between about 25 μm and about 60 μm , or between about 30 μm and about 50 μm . In still other embodiments, the optical pathlength is about 50 μm , or about 25 μm . In some instances, it is desirable to hold the pathlength T to within about plus or minus 1 μm from any pathlength specified by the analyte detection system with which the sample element **1730** is to be employed. Likewise, it may be desirable to orient the walls **1802c**, **1802d** with respect to each other within plus or minus 1 μm of parallel, and/or to maintain each of the walls **1802c**, **1802d** to within plus or minus 1 μm of planar (flat), depending on the analyte detection system with which the sample element **1730** is to be used. In alternative embodiments, walls **1802c**, **1802d** are flat, textured, angled, or some combination thereof.

[0258] In one embodiment, the transverse size of the sample chamber **903** (i.e., the size defined by the lateral chamber walls **1802a**, **1802b**) is about equal to the size of the active surface of the sample detector **1745**. Accordingly, in a further embodiment the sample chamber **903** is round with a diameter of about 4 millimeter to about 12 millimeter, and more preferably from about 6 millimeter to about 8 millimeter.

[0259] The sample element **1730** shown in FIGURES 18-19 has, in one embodiment, sizes and dimensions specified as follows. The supply passage **1804** preferably has a length of about 15 millimeter, a width of about 1.0 millimeter, and a height equal to the pathlength T. Additionally, the supply opening **1806** is preferably about 1.5 millimeter wide and smoothly transitions to the width of the sample supply passage **1804**. The sample element **1730** is about 0.5 inches (12 millimeters) wide and about one inch (25 millimeters) long with an overall thickness of between about 1.0 millimeter and about 4.0 millimeter. The vent passage **1808** preferably has a length of about 1.0 millimeter to 5.0 millimeter and a width of about 1.0 millimeter, with a thickness substantially equal to the pathlength between the walls **1802c**, **1802d**. The vent aperture **1810** is of substantially the same height and width as the vent passage **1808**. Of course, other dimensions may be

employed in other embodiments while still achieving the advantages of the sample element 1730.

[0260] The sample element 1730 is preferably sized to receive a material sample S having a volume less than or equal to about 15 μL (or less than or equal to about 10 μL , or less than or equal to about 5 μL) and more preferably a material sample S having a volume less than or equal to about 2 μL . Of course, the volume of the sample element 1730, the volume of the sample chamber 903, etc. can vary, depending on many variables, such as the size and sensitivity of the sample detector 1745, the intensity of the radiation emitted by the energy source 1720, the expected flow properties of the sample, and whether flow enhancers are incorporated into the sample element 1730. The transport of fluid to the sample chamber 903 is achieved preferably through capillary action, but may also be achieved through wicking or vacuum action, or a combination of wicking, capillary action, peristaltic, pumping, and/or vacuum action.

[0261] FIGURE 20 depicts one approach to constructing the sample element 1730. In this approach, the sample element 1730 comprises a first layer 1820, a second layer 1830, and a third layer 1840. The second layer 1830 is preferably positioned between the first layer 1820 and the third layer 1840. The first layer 1820 forms the upper chamber wall 1802c, and the third layer 1840 forms the lower chamber wall 1802d. Where either of the chamber walls 1802c, 1802d comprises a window, the window(s)/wall(s) 1802c/1802d in question may be formed from a different material as is employed to form the balance of the layer(s) 1820/1840 in which the wall(s) are located. Alternatively, the entirety of the layer(s) 1820/1840 may be formed of the material selected to form the window(s)/wall(s) 1802c, 1802d. In this case, the window(s)/wall(s) 1802c, 1802d are integrally formed with the layer(s) 1820, 1840 and simply comprise the regions of the respective layer(s) 1820, 1840 which overlie the sample chamber 903.

[0262] With further reference to FIGURE 20, second layer 1830 may be formed entirely of an adhesive that joins the first and third layers 1820, 1840. In other embodiments, the second layer 1830 may be formed from similar materials as the first and third layers, or any other suitable material. The second layer 1830 may also be formed as a carrier with an adhesive deposited on both sides thereof. The second layer 1830 includes voids which at least partially form the sample chamber 903, sample supply passage 1804, supply opening 1806, vent passage 1808, and vent opening 1810. The thickness of the second layer 1830 can be the same as any of the pathlengths disclosed above as suitable for

the sample element 1730. The first and third layers can be formed from any of the materials disclosed above as suitable for forming the window(s) of the sample element 1730. In one embodiment, layers 1820, 1840 are formed from material having sufficient structural integrity to maintain its shape when filled with a sample S. Layers 1820, 1830 may be, for example, calcium fluoride having a thickness of 0.5 millimeter. In another embodiment, the second layer 1830 comprises the adhesive portion of Adhesive Transfer Tape no. 9471LE available from 3M Corporation. In another embodiment, the second layer 1830 comprises an epoxy, available, for example, from TechFilm (31 Dunham Road, Billerica, MA 01821), that is bound to layers 1820, 1840 as a result of the application of pressure and heat to the layers.

[0263] The sample chamber 903 preferably comprises a reagentless chamber. In other words, the internal volume of the sample chamber 903 and/or the wall(s) 1802 defining the chamber 903 are preferably inert with respect to the sample to be drawn into the chamber for analysis. As used herein, "inert" is a broad term and is used in its ordinary sense and includes, without limitation, substances which will not react with the sample in a manner which will significantly affect any measurement made of the concentration of analyte(s) in the sample with sample analysis apparatus 322 or any other suitable system, for a sufficient time (e.g., about 1-30 minutes) following entry of the sample into the chamber 903, to permit measurement of the concentration of such analyte(s). Alternatively, the sample chamber 903 may contain one or more reagents to facilitate use of the sample element in sample assay techniques which involve reaction of the sample with a reagent.

[0264] In one embodiment of the present invention, sample element 1730 is used for a limited number of measurements and is disposable. Thus, for example, with reference to FIGURES 8-10, sample element 1730 forms a disposable portion of cassette 820 adapted to place sample chamber 903 within probe region 1002.

[0265] Additional information on sample elements, methods of use thereof, and related technologies may be found in the above-mentioned and incorporated U.S. Patent Application Publication No. 2005/0038357, published on February 17, 2005, titled SAMPLE ELEMENT WITH BARRIER MATERIAL; and in the above-mentioned and incorporated U.S. Patent Application No. 11/122,794, filed on May 5, 2005, titled SAMPLE ELEMENT WITH SEPARATOR.

SECTION IV.D – CENTRIFUGE

[0266] FIGURE 21 is a schematic of one embodiment of a sample preparation unit 2100 utilizing a centrifuge and which may be generally similar to the sample preparation unit 332, except as further detailed below. In general, the sample preparation unit 332 includes a centrifuge in place of, or in addition to a filter, such as the filter 1500. Sample preparation unit 2100 includes a fluid handling element in the form of a centrifuge 2110 having a sample element 2112 and a fluid interface 2120. Sample element 2112 is illustrated in FIGURE 21 as a somewhat cylindrical element. This embodiment is illustrative, and the sample element may be cylindrical, planar, or any other shape or configuration that is compatible with the function of holding a material (preferably a liquid) in the centrifuge 2110. The centrifuge 2110 can be used to rotate the sample element 2112 such that the material held in the sample element 2112 is separated.

[0267] In some embodiments, the fluid interface 2120 selectively controls the transfer of a sample from the passageway 113 and into the sample element 2112 to permit centrifuging of the sample. In another embodiment, the fluid interface 2120 also permits a fluid to flow through the sample element 2112 to cleanse or otherwise prepare the sample element for obtaining an analyte measurement. Thus, the fluid interface 2120 can be used to flush and fill the sample element 2112.

[0268] As shown in FIGURE 21, the centrifuge 2110 comprises a rotor 2111 that includes the sample element 2112 and an axle 2113 attached to a motor, not shown, which is controlled by the controller 210. The sample element 2112 is preferably generally similar to the sample element 1730 except as described subsequently.

[0269] As is further shown in FIGURE 21, fluid interface 2120 includes a fluid injection probe 2121 having a first needle 2122 and a fluid removal probe 2123. The fluid removal probe 2123 has a second needle 2124. When sample element 2112 is properly oriented relative to fluid interface 2120, a sample, fluid, or other liquid is dispensed into or passes through the sample element 2112. More specifically, fluid injection probe 2121 includes a passageway to receive a sample, such as a bodily fluid from the patient connector 110. The bodily fluid can be passed through the fluid injection probe 2121 and the first needle 2122 into the sample element 2112. To remove material from the sample element 2112, the sample 2112 can be aligned with the second needle 2124, as illustrated. Material can be passed through the second needle 2124 into the fluid removal probe 2123. The

material can then pass through a passageway of the removal probe **2123** away from the sample element **2112**.

[0270] One position that the sample element **2112** may be rotated through or to is a sample measurement location **2140**. The location **2140** may coincide with a region of an analysis system, such as an optical analyte detection system. For example, the location **2140** may coincide with a probe region **1002**, or with a measurement location of another apparatus.

[0271] The rotor **2111** may be driven in a direction indicated by arrow R, resulting in a centrifugal force on sample(s) within sample element **2112**. The rotation of a sample(s) located a distance from the center of rotation creates centrifugal force. In some embodiments, the sample element **2112** holds whole blood. The centrifugal force may cause the denser parts of the whole blood sample to move further out from the center of rotation than lighter parts of the blood sample. As such, one or more components of the whole blood can be separated from each other. Other fluids or samples can also be removed by centrifugal forces. In one embodiment, the sample element **2112** is a disposable container that is mounted on to a disposable rotor **2111**. Preferably, the container is plastic, reusable and flushable. In other embodiments, the sample element **2112** is a non-disposable container that is permanently attached to the rotor **2111**.

[0272] The illustrated rotor **2111** is a generally circular plate that is fixedly coupled to the axle **2113**. The rotor **2111** can alternatively have other shapes. The rotor **2111** preferably comprises a material that has a low density to keep the rotational inertia low and that is sufficiently strong and stable to maintain shape under operating loads to maintain close optical alignment. For example, the rotor **2111** can be comprised of GE brand ULTEM (trademark) polyetherimide (PEI). This material is available in a plate form that is stable but can be readily machined. Other materials having similar properties can also be used.

[0273] The size of the rotor **2111** can be selected to achieve the desired centrifugal force. In some embodiments, the diameter of rotor **2111** is from about 75 millimeters to about 125 millimeters, or more preferably from about 100 millimeters to about 125 millimeters. The thickness of rotor **2111** is preferably just thick enough to support the centrifugal forces and can be, for example, from about 1.0 to 2.0 millimeter thick.

[0274] In an alternative embodiment, the fluid interface **2120** selectively removes blood plasma from the sample element **2112** after centrifuging. The blood plasma is then delivered to an analyte detection system for analysis. In one embodiment, the separated fluids are removed from the sample element **2112** through the bottom connector. Preferably, the location and orientation of the bottom connector and the container allow the red blood cells to be removed first. One embodiment may be configured with a red blood cell detector. The red blood cell detector may detect when most of the red blood cells have exited the container by determining the haemostatic level. The plasma remaining in the container may then be diverted into the analysis chamber. After the fluids have been removed from the container, the top connector may inject fluid (e.g., saline) into the container to flush the system and prepare it for the next sample.

[0275] FIGURES 22A to 23C illustrate another embodiment of a fluid handling and analysis apparatus **140**, which employs a removable, disposable fluid handling cassette **820**. The cassette **820** is equipped with a centrifuge rotor assembly **2016** to facilitate preparation and analysis of a sample. Except as further described below, the apparatus **140** of FIGURES 22A-22C can in certain embodiments be similar to any of the other embodiments of the apparatus **140** discussed herein, and the cassette **820** can in certain embodiments be similar to any of the embodiments of the cassettes **820** disclosed herein.

[0276] The removable fluid handling cassette **820** can be removably engaged with a main analysis instrument **810**. When the fluid handling cassette **820** is coupled to the main instrument **810**, a drive system **2030** of the main instrument **810** mates with the rotor assembly **2016** of the cassette **820** (FIGURE 22B). Once the cassette **820** is coupled to the main instrument **810**, the drive system **2030** engages and can rotate the rotor assembly **2016** to apply a centrifugal force to a body fluid sample carried by the rotor assembly **2016**.

[0277] In some embodiments, the rotor assembly **2016** includes a rotor **2020** sample element **2448** (FIGURE 22C) for holding a sample for centrifuging. When the rotor **2020** is rotated, a centrifugal force is applied to the sample contained within the sample element **2448**. The centrifugal force causes separation of one or more components of the sample (e.g., separation of plasma from whole blood). The separated component(s) can then be analyzed by the apparatus **140**, as will be discussed in further detail below.

[0278] The main instrument **810** includes both the centrifuge drive system **2030** and an analyte detection system **1700**, a portion of which protrudes from a housing **2049** of

the main instrument **810**. The drive system **2030** is configured to releasably couple with the rotor assembly **2016**, and can impart rotary motion to the rotor assembly **2016** to rotate the rotor **2020** at a desired speed. After the centrifuging process, the analyte detection system **1700** can analyze one or more components separated from the sample carried by the rotor **2020**. The projecting portion of the illustrated detection system **1700** forms a slot **2074** for receiving a portion of the rotor **2020** carrying the sample element **2448** so that the detection system **1700** can analyze the sample or component(s) carried in the sample element **2448**.

[0279] To assemble the fluid handling and analysis apparatus **140** as shown in FIGURE 22C, the cassette **820** is placed on the main instrument **810**, as indicated by the arrow **2007** of FIGURES 22A and 22B. The rotor assembly **2016** is accessible to the drive system **2030**, so that once the cassette **820** is properly mounted on the main instrument **810**, the drive system **2030** is in operative engagement with the rotor assembly **2016**. The drive system **2030** is then energized to spin the rotor **2020** at a desired speed. The spinning rotor **2020** can pass repeatedly through the slot **2074** of the detection system **1700**.

[0280] After the centrifuging process, the rotor **2020** is rotated to an analysis position (see FIGURES 22B and 23C) wherein the sample element **2448** is positioned within the slot **2074**. With the rotor **2020** and sample element **2448** in the analysis position, the analyte detection system **1700** can analyze one or more of the components of the sample carried in the sample element **2448**. For example, the detection system **1700** can analyze at least one of the components that is separated out during the centrifuging process. After using the cassette **820**, the cassette **820** can be removed from the main instrument **810** and discarded. Another cassette **820** can then be mounted to the main instrument **810**.

[0281] With reference to FIGURE 23A, the illustrated cassette **820** includes the housing **2400** that surrounds the rotor assembly **2016**, and the rotor **2020** is pivotally connected to the housing **2400** by the rotor assembly **2016**. The rotor **2020** includes a rotor interface **2051** for driving engagement with the drive system **2030** upon placement of the cassette **820** on the main instrument **810**.

[0282] In some embodiments, the cassette **820** is a disposable fluid handling cassette. The reusable main instrument **810** can be used with any number of cassettes **820** as desired. Additionally or alternatively, the cassette **820** can be a portable, handheld cassette for convenient transport. In these embodiments, the cassette **820** can be manually mounted to or removed from the main instrument **810**. In some embodiments, the cassette

820 may be a non disposable cassette which can be permanently coupled to the main instrument 810.

[0283] FIGURES 25A and 25B illustrate the centrifugal rotor 2020, which is capable of carrying a sample, such as bodily fluid. Thus, the illustrated centrifugal rotor 2020 can be considered a fluid handling element that can prepare a sample for analysis, as well as hold the sample during a spectroscopic analysis. The rotor 2020 preferably comprises an elongate body 2446, at least one sample element 2448, and at least one bypass element 2452. The sample element 2448 and bypass element 2452 can be located at opposing ends of the rotor 2020. The bypass element 2452 provides a bypass flow path that can be used to clean or flush fluid passageways of the fluid handling and analysis apparatus 140 without passing fluid through the sample element 2448.

[0284] The illustrated rotor body 2446 can be a generally planar member that defines a mounting aperture 2447 for coupling to the drive system 2030. The illustrated rotor 2020 has a somewhat rectangular shape. In alternative embodiments, the rotor 2020 is generally circular, polygonal, elliptical, or can have any other shape as desired. The illustrated shape can facilitate loading when positioned horizontally to accommodate the analyte detection system 1700.

[0285] With reference to FIGURE 25B, a pair of opposing first and second fluid connectors 2027, 2029 extends outwardly from a front face of the rotor 2020, to facilitate fluid flow through the rotor body 2446 to the sample element 2448 and bypass element 2452, respectively. The first fluid connector 2027 defines an outlet port 2472 and an inlet port 2474 that are in fluid communication with the sample element 2448. In the illustrated embodiment, fluid channels 2510, 2512 extend from the outlet port 2472 and inlet port 2474, respectively, to the sample element 2448. (See FIGURES 25E and 25F.) As such, the ports 2472, 2474 and channels 2510, 2512 define input and return flow paths through the rotor 2020 to the sample element 2448 and back.

[0286] With continued reference to FIGURE 25B, the rotor 2020 includes the bypass element 2452 which permits fluid flow therethrough from an outlet port 2572 to the inlet port 2574. A channel 2570 extends between the outlet port 2572 and the inlet port 2574 to facilitate this fluid flow. The channel 2570 thus defines a closed flow path through the rotor 2020 from one port 2572 to the other port 2574. In the illustrated embodiment, the outlet port 2572 and inlet port 2574 of the bypass element 2452 have generally the same spacing therebetween on the rotor 2020 as the outlet port 2472 and the inlet port 2474.

[0287] One or more windows **2460a**, **2460b** can be provided for optical access through the rotor **2020**. A window **2460a** proximate the bypass element **2452** can be a through-hole (see FIGURE 25E) that permits the passage of electromagnetic radiation through the rotor **2020**. A window **2460b** proximate the sample element **2448** can also be a similar through-hole which permits the passage of electromagnetic radiation. Alternatively, one or both of the windows **2460a**, **2460b** can be a sheet constructed of calcium fluoride, barium fluoride, germanium, silicon, polypropylene, polyethylene, combinations thereof, or any material with suitable transmissivity (i.e., transmittance per unit thickness) in the relevant wavelength(s). The windows **2460a**, **2460b** are positioned so that one of the windows **2460a**, **2460b** is positioned in the slot **2074** when the rotor **2020** is in a vertically orientated position.

[0288] Various fabrication techniques can be used to form the rotor **2020**. In some embodiments, the rotor **2020** can be formed by molding (e.g., compression or injection molding), machining, or a similar production process or combination of production processes. In some embodiments, the rotor **2020** is comprised of plastic. The compliance of the plastic material can be selected to create the seal with the ends of pins **2542**, **2544** of a fluid interface **2028** (discussed in further detail below). Non-limiting exemplary plastics for forming the ports (e.g., ports **2572**, **2574**, **2472**, **2474**) can be relatively chemically inert and can be injection molded or machined. These plastics include, but are not limited to, PEEK and polyphenylenesulfide (PPS). Although both of these plastics have high modulus, a fluidic seal can be made if sealing surfaces are produced with smooth finish and the sealing zone is a small area where high contact pressure is created in a very small zone. Accordingly, the materials used to form the rotor **2020** and pins **2542**, **2544** can be selected to achieve the desired interaction between the rotor **2020** and the pins **2542**, **2544**, as described in detail below.

[0289] The illustrated rotor assembly **2016** of FIGURE 23A rotatably connects the rotor **2020** to the cassette housing **2400** via a rotor axle boss **2426** which is fixed with respect to the cassette housing and pivotally holds a rotor axle **2430** and the rotor **2020** attached thereto. The rotor axle **2430** extends outwardly from the rotor axle boss **2426** and is fixedly attached to a rotor bracket **2436**, which is preferably securely coupled to a rear face of the rotor **2020**. Accordingly, the rotor assembly **2016** and the drive system **2030** cooperate to ensure that the rotor **2020** rotates about the axis **2024**, even at high speeds. The illustrated cassette **820** has a single rotor assembly **2016**. In other embodiments, the

cassette **820** can have more than one rotor assembly **2016**. Multiple rotor assemblies **2016** can be used to prepare (preferably simultaneously) and test multiple samples.

[0290] With reference again to FIGURES 25A, 25B, 25E and 25F, the sample element **2448** is coupled to the rotor **2020** and can hold a sample of body fluid for processing with the centrifuge. The sample element **2448** can, in certain embodiments, be generally similar to other sample elements or cuvettes disclosed herein (e.g., sample elements **1730**, **2112**) except as further detailed below.

[0291] The sample element **2448** comprises a sample chamber **2464** that holds a sample for centrifuging, and fluid channels **2466**, **2468**, which provide fluid communication between the chamber **2464** and the channels **2512**, **2510**, respectively, of the rotor **2020**. Thus, the fluid channels **2512**, **2466** define a first flow path between the port **2474** and the chamber **2464**, and the channels **2510**, **2468** define a second flow path between the port **2472** and the chamber **2464**. Depending on the direction of fluid flow into the sample element **2448**, either of the first or second flow paths can serve as an input flow path, and the other can serve as a return flow path.

[0292] A portion of the sample chamber **2464** can be considered an interrogation region **2091**, which is the portion of the sample chamber through which electromagnetic radiation passes during analysis by the detection system **1700** of fluid contained in the chamber **2464**. Accordingly, the interrogation region **2091** is aligned with the window **2460b** when the sample element **2448** is coupled to the rotor **2020**. The illustrated interrogation region **2091** comprises a radially inward portion (i.e., relatively close to the axis of rotation **2024** of the rotor **2020**) of the chamber **2464**, to facilitate spectroscopic analysis of the lower density portion(s) of the body fluid sample (e.g., the plasma of a whole blood sample) after centrifuging, as will be discussed in greater detail below. Where the higher-density portions of the body fluid sample are of interest for spectroscopic analysis, the interrogation region **2091** can be located in a radially outward (i.e., further from the axis of rotation **2024** of the rotor **2020**) portion of the chamber **2464**.

[0293] The rotor **2020** can temporarily or permanently hold the sample element **2448**. As shown in FIGURE 25F, the rotor **2020** forms a recess **2502** which receives the sample element **2448**. The sample element **2448** can be held in the recess **2502** by frictional interaction, adhesives, or any other suitable coupling means. The illustrated sample element **2448** is recessed in the rotor **2020**. However, the sample element **2448** can alternatively overlie or protrude from the rotor **2020**.

[0294] The sample element 2448 can be used for a predetermined length of time, to prepare a predetermined amount of sample fluid, to perform a number of analyses, etc. If desired, the sample element 2448 can be removed from the rotor 2020 and then discarded. Another sample element 2448 can then be placed into the recess 2502. Thus, even if the cassette 820 is disposable, a plurality of disposable sample elements 2448 can be used with a single cassette 820. Accordingly, a single cassette 820 can be used with any number of sample elements as desired. Alternatively, the cassette 820 can have a sample element 2448 that is permanently coupled to the rotor 2020. In some embodiments, at least a portion of the sample element 2448 is integrally or monolithically formed with the rotor body 2446. Additionally or alternatively, the rotor 2020 can comprise a plurality of sample elements (e.g., with a record sample element in place of the bypass 2452). In this embodiment, a plurality of samples (e.g., bodily fluid) can be prepared simultaneously to reduce sample preparation time.

[0295] FIGURES 26A and 26B illustrate a layered construction technique which can be employed when forming certain embodiments of the sample element 2448. The depicted layered sample element 2448 comprises a first layer 2473, a second layer 2475, and a third layer 2478. The second layer 2475 is preferably positioned between the first layer 2473 and the third layer 2478. The first layer 2473 forms an upper chamber wall 2482, and the third layer 2478 forms a lower chamber wall 2484. A lateral wall 2490 of the second layer 2475 defines the sides of the chamber 2464 and the fluid channels 2466, 2468.

[0296] The second layer 2475 can be formed by die-cutting a substantially uniform-thickness sheet of a material to form the lateral wall pattern shown in FIGURE 26A. The second layer 2475 can comprise a layer of lightweight flexible material, such as a polymer material, with adhesive disposed on either side thereof to adhere the first and third layers 2473, 2478 to the second layer 2475 in “sandwich” fashion as shown in FIGURE 26B. Alternatively, the second layer 2475 can comprise an “adhesive-only” layer formed from a uniform-thickness sheet of adhesive which has been die-cut to form the depicted lateral wall pattern.

[0297] However constructed, the second layer 2475 is preferably of uniform thickness to define a substantially uniform thickness or path length of the sample chamber 2464 and/or interrogation region 2091. This path length (and therefore the thickness of the second layer 2475 as well) is preferably between 10 microns and 100 microns, or is 20, 40, 50, 60, or 80 microns, in various embodiments.

[0298] The upper chamber wall 2482, lower chamber wall 2484, and lateral wall 2490 cooperate to form the chamber 2464. The upper chamber wall 2482 and/or the lower chamber wall 2484 can permit the passage of electromagnetic energy therethrough. Accordingly, one or both of the first and third layers 2473, 2478 comprises a sheet or layer of material which is relatively or highly transmissive of electromagnetic radiation (preferably infrared radiation or mid-infrared radiation) such as barium fluoride, silicon, polyethylene or polypropylene. If only one of the layers 2473, 2478 is so transmissive, the other of the layers is preferably reflective, to back-reflect the incoming radiation beam for detection on the same side of the sample element 2448 as it was emitted. Thus the upper chamber wall 2482 and/or lower chamber wall 2484 can be considered optical window(s). These window(s) are disposed on one or both sides of the interrogation region 2091 of the sample element 2448.

[0299] In one embodiment, sample element 2448 has opposing sides that are transmissive of infrared radiation and suitable for making optical measurements as described, for example, in U.S. Patent Application Publication No. 2005/0036146, published February 17, 2005, titled SAMPLE ELEMENT QUALIFICATION, and hereby incorporated by reference and made a part of this specification. Except as further described herein, the embodiments, features, systems, devices, materials, methods and techniques described herein may, in some embodiments, be similar to any one or more of the embodiments, features, systems, devices, materials, methods and techniques described in U.S. Patent Application Publication No. 2003/0090649, published on May 15, 2003, titled REAGENT-LESS WHOLE-BLOOD GLUCOSE METER; or in U.S. Patent Application Publication No. 2003/0086075, published on May 8, 2003, titled DEVICE AND METHOD FOR IN VITRO DETERMINATION OF ANALYTE CONCENTRATIONS WITHIN BODY FLUIDS; or in U.S. Patent Application Publication No. 2004/0019431, published on January 29, 2004, titled METHOD OF DETERMINING AN ANALYTE CONCENTRATION IN A SAMPLE FROM AN ABSORPTION SPECTRUM, or in U.S. Patent No. 6,652,136, issued on November 25, 2003 to Marziali, titled METHOD OF SIMULTANEOUS MIXING OF SAMPLES. In addition, the embodiments, features, systems, devices, materials, methods and techniques described herein may, in certain embodiments, be applied to or used in connection with any one or more of the embodiments, features, systems, devices, materials, methods and techniques disclosed in the above-mentioned U.S. Patent Applications Publications Nos. 2003/0090649;

2003/0086075; 2004/0019431; or U.S. Patent No. 6,652,136. All of the above-mentioned publications and patent are hereby incorporated by reference herein and made a part of this specification.

[0300] With reference to FIGURES 23B and 23C, the cassette **820** can further comprise the movable fluid interface **2028** for filling and/or removing sample liquid from the sample element **2448**. In the depicted embodiment, the fluid interface **2028** is rotatably mounted to the housing **2400** of the cassette **820**. The fluid interface **2028** can be actuated between a lowered position (FIGURE 22C) and a raised or filling position (FIGURE 27C). When the interface **2028** is in the lowered position, the rotor **2020** can freely rotate. To transfer sample fluid to the sample element **2448**, the rotor **2020** can be held stationary and in a sample element loading position (see FIGURE 22C) the fluid interface **2028** can be actuated, as indicated by the arrow **2590**, upwardly to the filling position. When the fluid interface **2028** is in the filling position, the fluid interface **2028** can deliver sample fluid into the sample element **2448** and/or remove sample fluid from the sample element **2448**.

[0301] With continued reference to FIGURES 27A and 27B, the fluid interface **2028** has a main body **2580** that is rotatably mounted to the housing **2400** of the cassette **820**. Opposing brackets **2581**, **2584** can be employed to rotatably couple the main body **2580** to the housing **2400** of the cassette **820**, and permit rotation of the main body **2580** and the pins **2542**, **2544** about an axis of rotation **2590** between the lowered position and the filling position. The main instrument **810** can include a horizontally moveable actuator (not shown) in the form of a solenoid, pneumatic actuator, etc. which is extendible through an opening **2404** in the cassette housing **2400** (see FIG. 23B). Upon extension, the actuator strikes the main body **2580** of the fluid interface **2028**, causing the body **2580** to rotate to the filling position shown in FIGURE 27C. The main body **2580** is preferably spring-biased towards the retracted position (shown in FIGURE 23A) so that retraction of the actuator allows the main body to return to the retracted position. The fluid interface **2028** can thus be actuated for periodically placing fluid passageways of the pins **2542**, **2544** in fluid communication with a sample element **2448** located on the rotor **2020**.

[0302] The fluid interface **2028** of FIGURES 27A and 23B includes fluid connectors **2530**, **2532** that can provide fluid communication between the interface **2028** and one or more of the fluid passageways of the apparatus **140** and/or sampling system **100/800**, as will be discussed in further detail below. The illustrated connectors **2530**, **2532** are in an upwardly extending orientation and positioned at opposing ends of the main body

2580. The connectors 2530, 2532 can be situated in other orientations and/or positioned at other locations along the main body 2580. The main body 2580 includes a first inner passageway (not shown) which provides fluid communication between the connector 2530 and the pin 2542, and a second inner passageway (not shown) which provides fluid communication between the connector 2532 and the pin 2544.

[0303] The fluid pins 2542, 2544 extend outwardly from the main body 2580 and can engage the rotor 2020 to deliver and/or remove sample fluid to or from the rotor 2020. The fluid pins 2542, 2544 have respective pin bodies 2561, 2563 and pin ends 2571, 2573. The pin ends 2571, 2573 are sized to fit within corresponding ports 2472, 2474 of the fluid connector 2027 and/or the ports 2572, 2574 of the fluid connector 2029, of the rotor 2020. The pin ends 2571, 2573 can be slightly chamfered at their tips to enhance the sealing between the pin ends 2571, 2573 and rotor ports. In some embodiments, the outer diameters of the pin ends 2573, 2571 are slightly larger than the inner diameters of the ports of the rotor 2020 to ensure a tight seal, and the inner diameters of the pins 2542, 2544 are preferably identical or very close to the inner diameters of the channels 2510, 2512 leading from the ports. In other embodiments, the outer diameter of the pin ends 2571, 2573 are equal to or less than the inner diameters of the ports of the rotor 2020.

[0304] The connections between the pins 2542, 2544 and the corresponding portions of the rotor 2020, either the ports 2472, 2474 leading to the sample element 2448 or the ports 2572, 2574 leading to the bypass element 2452, can be relatively simple and inexpensive. At least a portion of the rotor 2020 can be somewhat compliant to help ensure a seal is formed with the pins 2542, 2544. Alternatively or additionally, sealing members (e.g., gaskets, O-rings, and the like) can be used to inhibit leaking between the pin ends 2571, 2573 and corresponding ports 2472, 2474, 2572, 2574.

[0305] FIGURES 23A and 23B illustrate the cassette housing 2400 enclosing the rotor assembly 2016 and the fluid interface 2028. The housing 2400 can be a modular body that defines an aperture or opening 2404 dimensioned to receive a drive system housing 2050 when the cassette 820 is operatively coupled to the main instrument 810. The housing 2400 can protect the rotor 2020 from external forces and can also limit contamination of samples delivered to a sample element in the rotor 2020, when the cassette 820 is mounted to the main instrument 810.

[0306] The illustrated cassette 820 has a pair of opposing side walls 2041, 2043, top 2053, and a notch 2408 for mating with the detection system 1700. A front wall 2045

and rear wall 2047 extend between the side walls 2041, 2043. The rotor assembly 2016 is mounted to the inner surface of the rear wall 2047. The front wall 2045 is configured to mate with the main instrument 810 while providing the drive system 2030 with access to the rotor assembly 2016.

[0307] The illustrated front wall 2045 has the opening 2404 that provides access to the rotor assembly 2016. The drive system 2030 can be passed through the opening 2404 into the interior of the cassette 820 until it operatively engages the rotor assembly 2016. The opening 2404 of FIGURE 23B is configured to mate and tightly surround the drive system 2030. The illustrated opening 2404 is generally circular and includes an upper notch 2405 to permit the fluid interface actuator of the main instrument 810 to access the fluid interface 2028, as discussed above. The opening 2404 can have other configurations suitable for admitting the drive system 2030 and actuator into the cassette 820.

[0308] The notch 2408 of the housing 2400 can at least partially surround the projecting portion of the analyte detection system 1700 when the cassette 820 is loaded onto the main instrument 810. The illustrated notch 2408 defines a cassette slot 2410 (FIGURE 23A) that is aligned with elongate slot 2074 shown in FIGURE 22C, upon loading of the cassette 820. The rotating rotor 2020 can thus pass through the aligned slots 2410, 2074. In some embodiments, the notch 2408 has a generally U-shaped axial cross section as shown. More generally, the configuration of the notch 2408 can be selected based on the design of the projecting portion of the detection system 1700.

[0309] Although not illustrated, fasteners, clips, mechanical fastening assemblies, snaps, or other coupling means can be used to ensure that the cassette 820 remains coupled to the main instrument 810 during operation. Alternatively, the interaction between the housing 2400 and the components of the main instrument 810 can secure the cassette 820 to the main instrument 810.

[0310] FIGURE 28 is a cross-sectional view of the main instrument 810. The illustrated centrifuge drive system 2030 extends outwardly from a front face 2046 of the main instrument 810 so that it can be easily mated with the rotor assembly 2016 of the cassette 820. When the centrifuge drive system 2030 is energized, the drive system 2030 can rotate the rotor 2020 at a desired rotational speed.

[0311] The illustrated centrifuge drive system 2030 of FIGURES 23E and 28 includes a centrifuge drive motor 2038 and a drive spindle 2034 that is drivingly connected to the drive motor 2038. The drive spindle 2034 extends outwardly from the drive motor

2038 and forms a centrifuge interface **2042**. The centrifuge interface **2042** extends outwardly from the drive system housing **2050**, which houses the drive motor **2038**. To impart rotary motion to the rotor **2020**, the centrifuge interface **2042** can have keying members, protrusions, notches, detents, recesses, pins, or other types of structures that can engage the rotor **2020** such that the drive spindle **2034** and rotor **2020** are coupled together.

[0312] The centrifuge drive motor **2038** of FIGURE 28 can be any suitable motor that can impart rotary motion to the rotor **2020**. When the drive motor **2038** is energized, the drive motor **2038** can rotate the drive spindle **2034** at constant or varying speeds. Various types of motors, including, but not limited to, centrifuge motors, stepper motors, spindle motors, electric motors, or any other type of motor for outputting a torque can be utilized. The centrifuge drive motor **2038** is preferably fixedly secured to the drive system housing **2050** of the main instrument **810**.

[0313] The drive motor **2038** can be the type of motor typically used in personal computer hard drives that is capable of rotating at about 7,200 RPM on precision bearings, such as a motor of a Seagate Model ST380011A hard drive (Seagate Technology, Scotts Valley, CA) or similar motor. In one embodiment, the drive spindle **2034** may be rotated at 6,000 rpm, which yields approximately 2,000 G's for a rotor having a 2.5 inch (64 millimeter) radius. In another embodiment, the drive spindle **2034** may be rotated at speeds of approximately 7,200 rpm. The rotational speed of the drive spindle **2034** can be selected to achieve the desired centrifugal force applied to a sample carried by the rotor **2020**.

[0314] The main instrument **810** includes a main housing **2049** that defines a chamber sized to accommodate a filter wheel assembly **2300** including a filter drive motor **2320** and filter wheel **2310** of the analyte detection system **1700**. The main housing **2049** defines a detection system opening **3001** configured to receive an analyte detection system housing **2070**. The illustrated analyte detection system housing **2070** extends or projects outwardly from the housing **2049**.

[0315] The main instrument **810** of FIGURES 23C and 23E includes a bubble sensor unit **321**, a pump **2619** in the form of a peristaltic pump roller **2620a** and a roller support **2620b**, and valves **323a**, **323b**. The illustrated valves **323a**, **323b** are pincher pairs, although other types of valves can be used. When the cassette **820** is installed, these components can engage components of a fluid handling network **2600** of the cassette **820**, as will be discussed in greater detail below.

[0316] With continued reference to FIGURE 28, the analyte detection system housing 2070 surrounds and houses some of the internal components of the analyte detection system 1700. The elongate slot 2074 extends downwardly from an upper face 2072 of the housing 2070. The elongated slot 2074 is sized and dimensioned so as to receive a portion of the rotor 2020. When the rotor 2020 rotates, the rotor 2020 passes periodically through the elongated slot 2074. When a sample element of the rotor 2020 is in the detection region 2080 defined by the slot 2074, the analyte detection system 1700 can analyze material in the sample element.

[0317] The analyte detection system 1700 can be a spectroscopic bodily fluid analyzer that preferably comprises an energy source 1720. The energy source 1720 can generate an energy beam directed along a major optical axis X that passes through the slot 2074 towards a sample detector 1745. The slot 2074 thus permits at least a portion of the rotor (e.g., the interrogation region 2091 or sample chamber 2464 of the sample element 2448) to be positioned on the optical axis X. To analyze a sample carried by the sample element 2448, the sample element and sample can be positioned in the detection region 2080 on the optical axis X such that light emitted from the source 1720 passes through the slot 2074 and the sample disposed within the sample element 2448.

[0318] The analyte detection system 1700 can also comprise one or more lenses positioned to transmit energy outputted from the energy source 1720. The illustrated analyte detection system 1700 of FIGURE 28 comprises a first lens 2084 and a second lens 2086. The first lens 2084 is configured to focus the energy from the source 1720 generally onto the sample element and material sample. The second lens 2086 is positioned between the sample element and the sample detector 1745. Energy from energy source 1720 passing through the sample element can subsequently pass through the second lens 2086. A third lens 2090 is preferably positioned between a beam splitter 2093 and a reference detector 2094. The reference detector 2094 is positioned to receive energy from the beam splitter 2093.

[0319] The analyte detection system 1700 can be used to determine the analyte concentration in the sample carried by the rotor 2020. Other types of detection or analysis systems can be used with the illustrated centrifuge apparatus or sample preparation unit. The fluid handling and analysis apparatus 140 is shown for illustrative purposes as being used in conjunction with the analyte detection system 1700, but neither the sample

preparation unit nor analyte detection system are intended to be limited to the illustrated configuration, or to be limited to being used together.

[0320] To assemble the fluid handling and analysis apparatus 140, the cassette 820 can be moved towards and installed onto the main instrument 810, as indicated by the arrow 2007 in FIGURE 22A. As the cassette 820 is installed, the drive system 2030 passes through the aperture 2040 so that the spindle 2034 mates with the rotor 2020. Simultaneously, the projecting portion of the detection system 1700 is received in the notch 2408 of the cassette 820. When the cassette 820 is installed on the main instrument 810, the slot 2410 of the notch 2048 and the slot 2074 of the detection system 1700 are aligned as shown in FIGURE 22C. Accordingly, when the cassette 820 and main instrument 810 are assembled, the rotor 2020 can rotate about the axis 2024 and pass through the slots 2410, 2074.

[0321] After the cassette 820 is assembled with the main instrument 810, a sample can be added to the sample element 2448. The cassette 820 can be connected to an infusion source and a patient to place the system in fluid communication with a bodily fluid to be analyzed. Once the cassette 820 is connected to a patient, a bodily fluid may be drawn from the patient into the cassette 820. The rotor 2020 is rotated to a vertical loading position wherein the sample element 2448 is near the fluid interface 2028 and the bypass element 2452 is positioned within the slot 2074 of the detection system 1700. Once the rotor 2020 is in the vertical loading position, the pins 2542, 2544 of the fluid interface 2028 are positioned to mate with the ports 2472, 2474 of the rotor 2020. The fluid interface 2028 is then rotated upwardly until the ends 2571, 2573 of the pins 2542, 2544 are inserted into the ports 2472, 2474.

[0322] When the fluid interface 2028 and the sample element 2448 are thus engaged, sample fluid (e.g., whole blood) is pumped into the sample element 2448. The sample can flow through the pin 2544 into and through the rotor channel 2512 and the sample element channel 2466, and into the sample chamber 2464. As shown in FIGURE 25C, the sample chamber 2464 can be partially or completely filled with sample fluid. In some embodiments, the sample fills at least the sample chamber 2464 and the interrogation region 2091 of the sample element 2448. The sample can optionally fill at least a portion of the sample element channels 2466, 2468. The illustrated sample chamber 2464 is filled with whole blood, although the sample chamber 2464 can be filled with other substances.

After the sample element 2448 is filled with a desired amount of fluid, the fluid interface 2028 can be moved to a lowered position to permit rotation of the rotor 2020.

[0323] The centrifuge drive system 2030 can then spin the rotor 2020 and associated sample element 2448 as needed to separate one or more components of the sample. The separated component(s) of the sample may collect or be segregated in a section of the sample element for analysis. In the illustrated embodiment, the sample element 2448 of FIGURE 25C is filled with whole blood prior to centrifuging. The centrifugal forces can be applied to the whole blood until plasma 2594 is separated from the blood cells 2592. After centrifuging, the plasma 2594 is preferably located in a radially inward portion of the sample element 2448, including the interrogation region 2091. The blood cells 2592 collect in a portion of the sample chamber 2464 which is radially outward of the plasma 2594 and interrogation region 2091.

[0324] The rotor 2020 can then be moved to a vertical analysis position wherein the sample element 2448 is disposed within the slot 2074 and aligned with the source 1720 and the sample detector 1745 on the major optical axis X. When the rotor 2020 is in the analysis position, the interrogation portion 2091 is preferably aligned with the major optical axis X of the detection system 1700. The analyte detection system 1700 can analyze the sample in the sample element 2448 using spectroscopic analysis techniques as discussed elsewhere herein.

[0325] After the sample has been analyzed, the sample can be removed from the sample element 2448. The sample may be transported to a waste receptacle so that the sample element 2448 can be reused for successive sample draws and analyses. The rotor 2020 is rotated from the analysis position back to the vertical loading position. To empty the sample element 2448, the fluid interface 2028 can again engage the sample element 2448 to flush the sample element 2448 with fresh fluid (either a new sample of body fluid, or infusion fluid). The fluid interface 2028 can be rotated to mate the pins 2542, 2544 with the ports 2472, 2474 of the rotor 2020. The fluid interface 2028 can pump a fluid through one of the pins 2542, 2544 until the sample is flushed from the sample element 2448. Various types of fluids, such as infusion liquid, air, water, and the like, can be used to flush the sample element 2448. After the sample element 2448 has been flushed, the sample element 2448 can once again be filled with another sample.

[0326] In an alternative embodiment, the sample element 2448 may be removed from the rotor 2020 and replaced after each separate analysis, or after a certain number of

analyses. Once the patient care has terminated, the fluid passageways or conduits may be disconnected from the patient and the sample cassette **820** which has come into fluid contact with the patient's bodily fluid may be disposed of or sterilized for reuse. The main instrument **810**, however, has not come into contact with the patient's bodily fluid at any point during the analysis and therefore can readily be connected to a new fluid handling cassette **820** and used for the analysis of a subsequent patient.

[0327] The rotor **2020** can be used to provide a fluid flow bypass. To facilitate a bypass flow, the rotor **2020** is first rotated to the vertical analysis/bypass position wherein the bypass element **2452** is near the fluid interface **2028** and the sample element **2448** is in the slot **2074** of the analyte detection system **1700**. Once the rotor **2020** is in the vertical analysis/bypass position, the pins **2542**, **2544** can mate with the ports **2572**, **2574** of the rotor **2020**. In the illustrated embodiment, the fluid interface **2028** is rotated upwardly until the ends **2571**, **2573** of the pins **2542**, **2544** are inserted into the ports **2572**, **2574**. The bypass element **2452** can then provide a completed fluid circuit so that fluid can flow through one of the pins **2542**, **2544** into the bypass element **2452**, through the bypass element **2452**, and then through the other pin **2542**, **2544**. The bypass element **2452** can be utilized in this manner to facilitate the flushing or sterilizing of a fluid system connected to the cassette **820**.

[0328] As shown in FIGURE 23B, the cassette **820** preferably includes the fluid handling network **2600** which can be employed to deliver fluid to the sample element **2448** in the rotor **2020** for analysis. The main instrument **810** has a number of components that can, upon installation of the cassette **820** on the main instrument **810**, extend through openings in the front face **2045** of cassette **820** to engage and interact with components of the fluid handling network **2600**, as detailed below.

[0329] The fluid handling network **2600** of the fluid handling and analysis apparatus **140** includes the passageway **111** which extends from the connector **120** toward and through the cassette **820** until it becomes the passageway **112**, which extends from the cassette **820** to the patient connector **110**. A portion **111a** of the passageway **111** extends across an opening **2613** in the front face **2045** of the cassette **820**. When the cassette **820** is installed on the main instrument **810**, the roller pump **2619** engages the portion **111a**, which becomes situated between the impeller **2620a** and the impeller support **2620b** (see FIGURE 23C).

[0330] The fluid handling network 2600 also includes passageway 113 which extends from the patient connector 110 towards and into the cassette 820. After entering the cassette 820, the passageway 113 extends across an opening 2615 in the front face 2045 to allow engagement of the passageway 113 with a bubble sensor 321 of the main instrument 810, when the cassette 820 is installed on the main instrument 810. The passageway 113 then proceeds to the connector 2532 of the fluid interface 2028, which extends the passageway 113 to the pin 2544. Fluid drawn from the patient into the passageway 113 can thus flow into and through the fluid interface 2028, to the pin 2544. The drawn body fluid can further flow from the pin 2544 and into the sample element 2448, as detailed above.

[0331] A passageway 2609 extends from the connector 2530 of the fluid interface 2028 and is thus in fluid communication with the pin 2542. The passageway 2609 branches to form the waste line 324 and the pump line 327. The waste line 324 passes across an opening 2617 in the front face 2045 and extends to the waste receptacle 325. The pump line 327 passes across an opening 2619 in the front face 2045 and extends to the pump 328. When the cassette 820 is installed on the main instrument 810, the pinch valves 323a, 323b extend through the openings 2617, 2619 to engage the lines 324, 327, respectively.

[0332] The waste receptacle 325 is mounted to the front face 2045. Waste fluid passing from the fluid interface 2028 can flow through the passageways 2609, 324 and into the waste receptacle 325. Once the waste receptacle 325 is filled, the cassette 820 can be removed from the main instrument 810 and discarded. Alternatively, the filled waste receptacle 325 can be replaced with an empty waste receptacle 325.

[0333] The pump 328 can be a displacement pump (e.g., a syringe pump). A piston control 2645 can extend over at least a portion of an opening 2621 in the cassette face 2045 to allow engagement with an actuator 2652 when the cassette 820 is installed on the main instrument 810. When the cassette 820 is installed, the actuator 2652 (FIGURE 23E) of the main instrument 810 engages the piston control 2645 of the pump 328 and can displace the piston control 2645 for a desired fluid flow.

[0334] It will be appreciated that, upon installing the cassette 820 of FIGURE 23A on the main instrument 810 of FIGURE 23E, there is formed (as shown in FIGURE 23E) a fluid circuit similar to that shown in the sampling unit 200 in FIGURE 3. This fluid circuit can be operated in a manner similar to that described above in connection with the

apparatus of FIGURE 3 (e.g., in accordance with the methodology illustrated in FIGURES 7A-7J and Table 1).

[0335] FIGURE 24A depicts another embodiment of a fluid handling network 2700 that can be employed in the cassette 820. The fluid handling network 2700 can be generally similar in structure and function to the network 2600 of FIGURE 23B, except as detailed below. The network 2700 includes the passageway 111 which extends from the connector 120 toward and through the cassette 820 until it becomes the passageway 112, which extends from the cassette 820 to the patient connector 110. A portion 111a of the passageway 111 extends across an opening 2713 in the front face 2745 of the cassette 820. When the cassette 820 is installed on the main instrument 810, a roller pump 2619 of the main instrument 810 of FIGURE 24B can engage the portion 111a in a manner similar to that described above with respect to FIGURES 23B-23C. The passageway 113 extends from the patient connector 110 towards and into the cassette 820. After entering the cassette 820, the passageway 113 extends across an opening 2763 in the front face 2745 to allow engagement with a valve 2733 of the main instrument 810. A waste line 2704 extends from the passageway 113 to the waste receptacle 325 and across an opening 2741 in the front face 2745. The passageway 113 proceeds to the connector 2532 of the fluid interface 2028, which extends the passageway 113 to the pin 2544. The passageway 113 crosses an opening 2743 in the front face 2745 to allow engagement of the passageway 113 with a bubble sensor 2741 of the main instrument 810 of FIGURE 24B. When the cassette 820 is installed on the main instrument 810, the pinch valves 2732, 2733 extend through the openings 2731, 2743 to engage the passageways 113, 2704, respectively.

[0336] The illustrated fluid handling network 2700 also includes a passageway 2723 which extends between the passageway 111 and a passageway 2727, which in turn extends between the passageway 2723 and the fluid interface 2028. The passageway 2727 extends across an opening 2733 in the front face 2745. A pump line 2139 extends from a pump 328 to the passageways 2723, 2727. When the cassette 820 is installed on the main instrument 810, the pinch valves 2716, 2718 extend through the openings 2725, 2733 in the front face 2745 to engage the passageways 2723, 2727, respectively.

[0337] It will be appreciated that, upon installing the cassette 820 on the main instrument 810 (as shown in FIGURE 24A), there is formed a fluid circuit that can be operated in a manner similar to that described above, in connection with the apparatus of FIGS. 9-10.

[0338] In view of the foregoing, it will be further appreciated that the various embodiments of the fluid handling and analysis apparatus **140** (comprising a main instrument **810** and cassette **820**) depicted in FIGURES 22A-28 can serve as the fluid handling and analysis apparatus **140** of any of the sampling systems **100/300/500**, or the fluid handling system **10**, depicted in FIGURES 1-5 herein. In addition, the fluid handling and analysis apparatus **140** of FIGURES 22A-28 can, in certain embodiments, be similar to the apparatus **140** of FIGURES 1-2 or 8-10, except as further described above.

SECTION V - METHODS FOR DETERMINING ANALYTE CONCENTRATIONS FROM SAMPLE SPECTRA

[0339] This section discusses a number of computational methods or algorithms which may be used to calculate the concentration of the analyte(s) of interest in the sample **S**, and/or to compute other measures that may be used in support of calculations of analyte concentrations. Any one or combination of the algorithms disclosed in this section may reside as program instructions stored in the memory **212** so as to be accessible for execution by the processor **210** of the fluid handling and analysis apparatus **140** or analyte detection system **334** to compute the concentration of the analyte(s) of interest in the sample, or other relevant measures.

[0340] Several disclosed embodiments are devices and methods for analyzing material sample measurements and for quantifying one or more analytes in the presence of interferents. Interferents can comprise components of a material sample being analyzed for an analyte, where the presence of the interferent affects the quantification of the analyte. Thus, for example, in the spectroscopic analysis of a sample to determine an analyte concentration, an interferent could be a compound having spectroscopic features that overlap with those of the analyte. The presence of such an interferent can introduce errors in the quantification of the analyte. More specifically, the presence of interferents can affect the sensitivity of a measurement technique to the concentration of analytes of interest in a material sample, especially when the system is calibrated in the absence of, or with an unknown amount of, the interferent.

[0341] Independently of or in combination with the attributes of interferents described above, interferents can be classified as being endogenous (i.e., originating within the body) or exogenous (i.e., introduced from or produced outside the body). As example of these classes of interferents, consider the analysis of a blood sample (or a blood component sample or a blood plasma sample) for the analyte glucose. Endogenous interferents include

those blood components having origins within the body that affect the quantification of glucose, and may include water, hemoglobin, blood cells, and any other component that naturally occurs in blood. Exogenous interferents include those blood components having origins outside of the body that affect the quantification of glucose, and can include items administered to a person, such as medicaments, drugs, foods or herbs, whether administered orally, intravenously, topically, etc.

[0342] Independently of or in combination with the attributes of interferents described above, interferents can comprise components which are possibly but not necessarily present in the sample type under analysis. In the example of analyzing samples of blood or blood plasma drawn from patients who are receiving medical treatment, a medicament such as acetaminophen is possibly, but not necessarily present in this sample type. In contrast, water is necessarily present in such blood or plasma samples.

[0343] To facilitate an understanding of the inventions, embodiments are discussed herein where one or more analyte concentrations are obtained using spectroscopic measurements of a sample at wavelengths including one or more wavelengths that are identified with the analyte(s). The embodiments disclosed herein are not meant to limit, except as claimed, the scope of certain disclosed inventions which are directed to the analysis of measurements in general.

[0344] As an example, certain disclosed methods are used to quantitatively estimate the concentration of one specific compound (an analyte) in a mixture from a measurement, where the mixture contains compounds (interferents) that affect the measurement. Certain disclosed embodiments are particularly effective if each analyte and interferent component has a characteristic signature in the measurement, and if the measurement is approximately affine (i.e., includes a linear component and an offset) with respect to the concentration of each analyte and interferent. In one embodiment, a method includes a calibration process including an algorithm for estimating a set of coefficients and an offset value that permits the quantitative estimation of an analyte. In another embodiment, there is provided a method for modifying hybrid linear algorithm (HLA) methods to accommodate a random set of interferents, while retaining a high degree of sensitivity to the desired component. The data employed to accommodate the random set of interferents are (a) the signatures of each of the members of the family of potential additional components and (b) the typical quantitative level at which each additional component, if present, is likely to appear.

[0345] Certain methods disclosed herein are directed to the estimation of analyte concentrations in a material sample in the possible presence of an interferent. In certain embodiments, any one or combination of the methods disclosed herein may be accessible and executable processor 210 of system 334. Processor 210 may be connected to a computer network, and data obtained from system 334 can be transmitted over the network to one or more separate computers that implement the methods. The disclosed methods can include the manipulation of data related to sample measurements and other information supplied to the methods (including, but not limited to, interferent spectra, sample population models, and threshold values, as described subsequently). Any or all of this information, as well as specific algorithms, may be updated or changed to improve the method or provide additional information, such as additional analytes or interferents.

[0346] Certain disclosed methods generate a "calibration constant" that, when multiplied by a measurement, produces an estimate of an analyte concentration. Both the calibration constant and measurement can comprise arrays of numbers. The calibration constant is calculated to minimize or reduce the sensitivity of the calibration to the presence of interferents that are identified as possibly being present in the sample. Certain methods described herein generate a calibration constant by: 1) identifying the presence of possible interferents; and 2) using information related to the identified interferents to generate the calibration constant. These certain methods do not require that the information related to the interferents includes an estimate of the interferent concentration - they merely require that the interferents be identified as possibly present. In one embodiment, the method uses a set of training spectra each having known analyte concentration(s) and produces a calibration that minimizes the variation in estimated analyte concentration with interferent concentration. The resulting calibration constant is proportional to analyte concentration(s) and, on average, is not responsive to interferent concentrations.

[0347] In one embodiment, it is not required (though not prohibited either) that the training spectra include any spectrum from the individual whose analyte concentration is to be determined. That is, the term "training" when used in reference to the disclosed methods does not require training using measurements from the individual whose analyte concentration will be estimated (e.g., by analyzing a bodily fluid sample drawn from the individual).

[0348] Several terms are used herein to describe the estimation process. As used herein, the term "Sample Population" is a broad term and includes, without limitation, a

large number of samples having measurements that are used in the computation of a calibration – in other words, used to train the method of generating a calibration. For an embodiment involving the spectroscopic determination of glucose concentration, the Sample Population measurements can each include a spectrum (analysis measurement) and a glucose concentration (analyte measurement). In one embodiment, the Sample Population measurements are stored in a database, referred to herein as a “Population Database.”

[0349] The Sample Population may or may not be derived from measurements of material samples that contain interferents to the measurement of the analyte(s) of interest. One distinction made herein between different interferents is based on whether the interferent is present in both the Sample Population and the sample being measured, or only in the sample. As used herein, the term “Type-A interferent” refers to an interferent that is present in both the Sample Population and in the material sample being measured to determine an analyte concentration. In certain methods it is assumed that the Sample Population includes only interferents that are endogenous, and does not include any exogenous interferents, and thus Type-A interferents are endogenous. The number of Type-A interferents depends on the measurement and analyte(s) of interest, and may number, in general, from zero to a very large number. The material sample being measured, for example sample S, may also include interferents that are not present in the Sample Population. As used herein, the term “Type-B interferent” refers to an interferent that is either: 1) not found in the Sample Population but that is found in the material sample being measured (e.g., an exogenous interferent), or 2) is found naturally in the Sample Population, but is at abnormally high concentrations in the material sample (e.g., an endogenous interferent). Examples of a Type-B exogenous interferent may include medications, and examples of Type-B endogenous interferents may include urea in persons suffering from renal failure. In the example of mid-IR spectroscopic absorption measurement of glucose in blood, water is found in all blood samples, and is thus a Type-A interferent. For a Sample Population made up of individuals who are not taking intravenous drugs, and a material sample taken from a hospital patient who is being administered a selected intravenous drug, the selected drug is a Type-B interferent.

[0350] In one embodiment, a list of one or more possible Type-B Interferents is referred to herein as forming a “Library of Interferents,” and each interferent in the library is referred to as a “Library Interferent.” The Library Interferents include exogenous interferents and endogenous interferents that may be present in a material sample due, for

example, to a medical condition causing abnormally high concentrations of the endogenous interferent.

[0351] In addition to components naturally found in the blood, the ingestion or injection of some medicines or illicit drugs can result in very high and rapidly changing concentrations of exogenous interferents. This results in problems in measuring analytes in blood of hospital or emergency room patients. An example of overlapping spectra of blood components and medicines is illustrated in FIGURE 29 as the absorption coefficient at the same concentration and optical pathlength of pure glucose and three spectral interferents, specifically mannitol (chemical formula: hexane-1,2,3,4,5,6-hexaol), N acetyl L cysteine, dextran, and procainamide (chemical formula: 4-amino-N-(2-diethylaminoethyl)benzamid). FIGURE 30 shows the logarithm of the change in absorption spectra from a Sample Population blood composition as a function of wavelength for blood containing additional likely concentrations of components, specifically, twice the glucose concentration of the Sample Population and various amounts of mannitol, N acetyl L cysteine, dextran, and procainamide. The presence of these components is seen to affect absorption over a wide range of wavelengths. It can be appreciated that the determination of the concentration of one species without a priori knowledge or independent measurement of the concentration of other species is problematic.

[0352] One method for estimating the concentration of an analyte in the presence of interferents is presented in flowchart 3100 of FIGURE 31 as a first step (Block 3110) where a measurement of a sample is obtained, a second step (Block 3120), where the obtained measurement data is analyzed to identify possible interferents to the analyte, a third step (Block 3130) where a model is generated for predicting the analyte concentration in the presence of the identified possible interferents, and a fourth step (Block 3140) where the model is used to estimate the analyte concentration in the sample from the measurement. Preferably the step of Block 3130 generates a model where the error is minimized for the presence of the identified interferents that are not present in a general population of which the sample is a member.

[0353] The method Blocks 3110, 3120, 3130, and 3140 may be repeatedly performed for each analyte whose concentration is required. If one measurement is sensitive to two or more analytes, then the methods of Blocks 3120, 3130, and 3140 may be repeated for each analyte. If each analyte has a separate measurement, then the methods of Blocks 3110, 3120, 3130, and 3140 may be repeated for each analyte.

[0354] An embodiment of the method of flowchart 3100 for the determination of an analyte from spectroscopic measurements will now be discussed. Further, this embodiment will estimate the amount of glucose concentration in blood sample S, without limit to the scope of the inventions disclosed herein. In one embodiment, the measurement of Block 3110 is an absorbance spectrum, $C_s(\lambda_i)$, of a measurement sample S that has, in general, one analyte of interest, glucose, and one or more interferents. In one embodiment, the methods include generating a calibration constant $\kappa(\lambda_i)$ that, when multiplied by the absorbance spectrum $C_s(\lambda_i)$, provides an estimate, g_{est} , of the glucose concentration g_s .

[0355] As described subsequently, one embodiment of Block 3120 includes a statistical comparison of the absorbance spectrum of sample S with a spectrum of the Sample Population and combinations of individual Library Interferent spectra. After the analysis of Block 3120, a list of Library Interferents that are possibly contained in sample S has been identified and includes, depending on the outcome of the analysis of Block 3120, either no Library Interferents, or one or more Library Interferents. Block 3130 then generates a large number of spectra using the large number of spectra of the Sample Population and their respective known analyte concentrations and known spectra of the identified Library Interferents. Block 3130 then uses the generated spectra to generate a calibration constant matrix to convert a measured spectrum to an analyte concentration that is the least sensitive to the presence of the identified Library Interferents. Block 3140 then applies the generated calibration constant to predict the glucose concentration in sample S.

[0356] As indicated in Block 3110, a measurement of a sample is obtained. For illustrative purposes, the measurement, $C_s(\lambda_i)$, is assumed to be a plurality of measurements at different wavelengths, or analyzed measurements, on a sample indicating the intensity of light that is absorbed by sample S. It is to be understood that spectroscopic measurements and computations may be performed in one or more domains including, but not limited to, the transmittance, absorbance and/or optical density domains. The measurement $C_s(\lambda_i)$ is an absorption, transmittance, optical density or other spectroscopic measurement of the sample at selected wavelength or wavelength bands. Such measurements may be obtained, for example, using analyte detection system 334. In general, sample S contains Type-A interferents, at concentrations preferably within the range of those found in the Sample Population.

[0357] In one embodiment, absorbance measurements are converted to pathlength normalized measurements. Thus, for example, the absorbance is converted to

optical density by dividing the absorbance by the optical pathlength, L, of the measurement. In one embodiment, the pathlength L is measured from one or more absorption measurements on known compounds. Thus, in one embodiment, one or more measurements of the absorption through a sample S of water or saline solutions of known concentration are made and the pathlength, L, is computed from the resulting absorption measurement(s). In another embodiment, absorption measurements are also obtained at portions of the spectrum that are not appreciably affected by the analytes and interferents, and the analyte measurement is supplemented with an absorption measurement at those wavelengths.

[0358] Some methods are "pathlength insensitive," in that they can be used even when the precise pathlength is not known beforehand. The sample can be placed in the sample chamber 903 or 2464, sample element 1730 or 2448, or in a cuvette or other sample container. Electromagnetic radiation (in the mid-infrared range, for example) can be emitted from a radiation source so that the radiation travels through the sample chamber. A detector can be positioned where the radiation emerges, on the other side of the sample chamber from the radiation source, for example. The distance the radiation travels through the sample can be referred to as a "pathlength." In some embodiments, the radiation detector can be located on the same side of the sample chamber as the radiation source, and the radiation can reflect off one or more internal walls of the sample chamber before reaching the detector.

[0359] As discussed above, various substances can be inserted into the sample chamber. For example, a reference fluid such as water or saline solution can be inserted, in addition to a sample or samples containing an analyte or analytes. In some embodiments, a saline reference fluid is inserted into the sample chamber and radiation is emitted through that reference fluid. The detector measures the amount and/or characteristics of the radiation that passes through the sample chamber and reference fluid without being absorbed or reflected. The measurement taken using the reference fluid can provide information relating to the pathlength traveled by the radiation. For example, data may already exist from previous measurements that have been taken under similar circumstances. That is, radiation can be emitted previously through sample chambers with various known pathlengths to establish reference data that can be arranged in a "look-up table," for example. With reference fluid in the sample chamber, a one-to-one correspondence can be experimentally established between various detector readings and

various pathlengths, respectively. This correspondence can be recorded in the look-up table, which can be recorded in a computer database or in electronic memory, for example.

[0360] One method of determining the radiation pathlength can be accomplished with a thin, empty sample chamber. In particular, this approach can determine the thickness of a narrow sample chamber or cell with two reflective walls. (Because the chamber will be filled with a sample, this same thickness corresponds to the "pathlength" radiation will travel through the sample). A range of radiation wavelengths can be emitted in a continuous manner through the cell or sample chamber. The radiation can enter the cell and reflect off the interior cell walls, bouncing back and forth between those walls one or multiple times before exiting the cell and passing into the radiation detector. This can create a periodic interference pattern or "fringe" with repeating maxima and minima. This periodic pattern can be plotted where the horizontal axis is a range of wavelengths and the vertical axis is a range of transmittance, measured as a percentage of total transmittance, for example. The maxima occur when the radiation reflected off of the two internal surfaces of the cell has traveled a distance that is an integral multiple N of the wavelength of the radiation that was transmitted without reflection. Constructive interference occurs whenever the wavelength is equal to $2b/N$, where "b" is the thickness (or pathlength) of the cell. Thus, if ΔN is the number of maxima in this fringe pattern for a given range of wavelengths λ_1 - λ_2 , then the thickness of the cell b is provided by the following relation: $b = \Delta N / 2(\lambda_1 - \lambda_2)$. This approach can be especially useful when the refractive index of the material within the sample chamber or fluid cell is not the same as the refractive index of the walls of the cell, because this condition improves reflection.

[0361] Once the pathlength has been determined, it can be used to calculate or determine a reference value or a reference spectrum for the interferences (such as protein or water) that may be present in a sample. For example, both an analyte such as glucose and an interferent such as water may absorb radiation at a given wavelength. When the source emits radiation of that wavelength and the radiation passes through a sample containing both the analyte and the interferent, both the analyte and the interferent absorb the radiation. The total absorption reading of the detector is thus fully attributable to neither the analyte nor the interferent, but a combination of the two. However, if data exists relating to how much radiation of a given wavelength is absorbed by a given interferent when the radiation passes through a sample with a given pathlength, the contribution of the interferent can be subtracted from the total reading of the detector and the remaining value can provide

information regarding concentration of the analyte in the sample. A similar approach can be taken for a whole spectrum of wavelengths. If data exists relating to how much radiation is absorbed by an interferent over a range of wavelengths when the radiation passes through a sample with a given pathlength, the interferent absorbance spectrum can be subtracted from the total absorbance spectrum, leaving only the analyte's absorbance spectrum for that range of wavelengths. If the interferent absorption data is taken for a range of possible pathlengths, it can be helpful to determine the pathlength of a particular sample chamber first so that the correct data can be found for samples measured in that sample chamber.

[0362] This same process can be applied iteratively or simultaneously for multiple interferents and/or multiple analytes. For example, the water absorbance spectrum and the protein absorbance spectrum can both be subtracted to leave behind the glucose absorbance spectrum.

[0363] The pathlength can also be calculated using an isosbestic wavelength. An isosbestic wavelength is one at which all components of a sample have the same absorbance. If the components (and their absorption coefficients) in a particular sample are known, and one or multiple isosbestic wavelengths are known for those particular components, the absorption data collected by the radiation detector at those isosbestic wavelengths can be used to calculate the pathlength. This can be advantageous because the needed information can be obtained from multiple readings of the absorption detector that are taken at approximately the same time, with the same sample in place in the sample chamber. The isosbestic wavelength readings are used to determine pathlength, and other selected wavelength readings are used to determine interferent and/or analyte concentration. Thus, this approach is efficient and does not require insertion of a reference fluid in the sample chamber.

[0364] In some embodiments, a method of determining concentration of an analyte in a sample can include inserting a fluid sample into a sample container, emitting radiation from a source through the container and the fluid sample, obtaining total sample absorbance data by measuring the amount of radiation that reaches the detector, subtracting the correct interferent absorbance value or spectrum from the total sample absorbance data, and using the remaining absorbance value or spectrum to determine concentration of an analyte in the fluid sample. The correct interferent absorbance value can be determined using the calculated pathlength.

[0365] The concentration of an analyte in a sample can be calculated using the Beer-Lambert law (or Beer's Law) as follows: If T is transmittance, A is absorbance, P_0 is initial radiant power directed toward a sample, and P is the power that emerges from the sample and reaches a detector, then $T = P / P_0$, and $A = -\log T = \log (P_0 / P)$. Absorbance is directly proportional to the concentration (c) of the light-absorbing species in the sample, also known as an analyte or an interferent. Thus, if e is the molar absorptivity ($1/M$ $1/cm$), b is the path length (cm), and c is the concentration (M), Beer's Law can be expressed as follows: $A = e b c$. Thus, $c = A/(e b)$.

[0366] Referring once again to flowchart 3100, the next step is to determine which Library Interferents are present in the sample. In particular, Block 3120 indicates that the measurements are analyzed to identify possible interferents. For spectroscopic measurements, it is preferred that the determination is made by comparing the obtained measurement to interferent spectra in the optical density domain. The results of this step provide a list of interferents that may, or are likely to, be present in the sample. In one embodiment, several input parameters are used to estimate a glucose concentration g_{est} from a measured spectrum, C_s . The input parameters include previously gathered spectrum measurement of samples that, like the measurement sample, include the analyte and combinations of possible interferents from the interferent library; and spectrum and concentration ranges for each possible interferent. More specifically, the input parameters are:

[0367] Library of Interferent Data: Library of Interferent Data includes, for each of "M" interferents, the absorption spectrum of each interferent, $IF = \{IF_1, IF_2, \dots, IF_M\}$, where $m = 1, 2, \dots, M$; and a maximum concentration for each interferent, $Tmax = \{Tmax_1, Tmax_2, \dots, Tmax_M\}$; and

[0368] Sample Population Data: Sample Population Data includes individual spectra of a statistically large population taken over the same wavelength range as the sample spectrum, C_{si} , and an analyte concentration corresponding to each spectrum. As an example, if there are N Sample Population spectra, then the spectra can be represented as $C = \{C_1, C_2, \dots, C_N\}$, where $n = 1, 2, \dots, N$, and the analyte concentration corresponding to each spectrum can be represented as $g = \{g_1, g_2, \dots, g_N\}$.

[0369] Preferably, the Sample Population does not have any of the M interferences present, and the material sample has interferences contained in the Sample Population and none or more of the Library Interferences. Stated in terms of Type-A and Type-B interferences, the Sample Population has Type-A interferences and the material sample has Type-A and may have Type-B interferences. The Sample Population Data are used to statistically quantify an expected range of spectra and analyte concentrations. Thus, for example, for a system 10 or 334 used to determine glucose in blood of a person having unknown spectral characteristics, the spectral measurements are preferably obtained from a statistical sample of the population.

[0370] The following discussion, which is not meant to limit the scope of the present disclosure, illustrates embodiments for measuring more than one analyte using spectroscopic techniques. If two or more analytes have non-overlapping spectral features, then a first embodiment is to obtain a spectrum corresponding to each analyte. The measurements may then be analyzed for each analyte according to the method of flowchart 3100. An alternative embodiment for analytes having non-overlapping features, or an embodiment for analytes having overlapping features, is to make one measurement comprising the spectral features of the two or more analytes. The measurement may then be analyzed for each analyte according to the method of flowchart 3100. That is, the measurement is analyzed for each analyte, with the other analytes considered to be interferences to the analyte being analyzed for.

INTERFERENT DETERMINATION

[0371] One embodiment of the method of Block 3120 is shown in greater detail with reference to the flowchart of FIGURE 32. The method includes forming a statistical Sample Population model (Block 3210), assembling a library of interference data (Block 3220), comparing the obtained measurement and statistical Sample Population model with data for each interference from an interference library (Block 3230), performing a statistical test for the presence of each interference from the interference library (Block 3240), and identifying each interference passing the statistical test as a possible Library Interference (Block 3250). The steps of Block 3220 can be performed once or can be updated as necessary. The steps of Blocks 3230, 3240, and 3250 can either be performed sequentially for all interferences of the library, as shown, or alternatively, be repeated sequentially for each interference.

[0372] One embodiment of each of the methods of Blocks 3210, 3220, 3230, 3240, and 3250 are now described for the example of identifying Library Interferents in a sample from a spectroscopic measurement using Sample Population Data and a Library of Interferent Data, as discussed previously. Each Sample Population spectrum includes measurements (e.g., of optical density) taken on a sample in the absence of any Library Interferents and has an associated known analyte concentration. A statistical Sample Population model is formed (Block 3210) for the range of analyte concentrations by combining all Sample Population spectra to obtain a mean matrix and a covariance matrix for the Sample Population. Thus, for example, if each spectrum at n different wavelengths is represented by an $n \times 1$ matrix, C , then the mean spectrum, μ , is a $n \times 1$ matrix with the (e.g., optical density) value at each wavelength averaged over the range of spectra, and the covariance matrix, V , is the expected value of the deviation between C and μ as $V = E((C - \mu)(C - \mu)^T)$. The matrices μ and V are one model that describes the statistical distribution of the Sample Population spectra.

[0373] In another step, Library Interferent information is assembled (Block 3220). A number of possible interferents are identified, for example as a list of possible medications or foods that might be ingested by the population of patients at issue or measured by system 10 or 334, and their spectra (in the absorbance, optical density, or transmission domains) are obtained. In addition, a range of expected interferent concentrations in the blood, or other expected sample material, are estimated. Thus, each of M interferents has spectrum IF and maximum concentration T_{max} . This information is preferably assembled once and is accessed as needed.

[0374] The obtained measurement data and statistical Sample Population model are next compared with data for each interferent from the interferent library (Block 3230) to perform a statistical test (Block 3240) to determine the identity of any interferent in the mixture (Block 3250). This interferent test will first be shown in a rigorous mathematical formulation, followed by a discussion of FIGURES 33A and 33B which illustrates the method.

[0375] Mathematically, the test of the presence of an interferent in a measurement proceeds as follows. The measured optical density spectrum, C_s , is modified for each interferent of the library by analytically subtracting the effect of the interferent, if present, on the measured spectrum. More specifically, the measured optical density spectrum, C_s , is modified, wavelength-by-wavelength, by subtracting an interferent optical

density spectrum. For an interferent, M , having an absorption spectrum per unit of interferent concentration, IF_M , a modified spectrum is given by $C'_s(T) = C_s - IF_M T$, where T is the interferent concentration, which ranges from a minimum value, T_{min} , to a maximum value T_{max} . The value of T_{min} may be zero or, alternatively, be a value between zero and T_{max} , such as some fraction of T_{max} .

[0376] Next, the Mahalanobis distance (MD) between the modified spectrum $C'_s(T)$ and the statistical model (μ, V) of the Sample Population spectra is calculated as:

$$[0377] \quad MD^2(C_s - (T IF_m), \mu; \rho_s) = (C_s - (T IF_m) - \mu)^T V^{-1} (C_s - (T IF_m) - \mu)$$

Eq. (1)

[0378] The test for the presence of interferent IF is to vary T from T_{min} to T_{max} (i.e., evaluate $C'_s(T)$ over a range of values of T) and determine whether the minimum MD in this interval is in a predetermined range. Thus for example, one could determine whether the minimum MD in the interval is sufficiently small relative to the quantiles of a χ^2 random variable with L degrees of freedom ($L =$ number of wavelengths).

[0379] FIGURE 33A is a graph 3300 illustrating the steps of Blocks 3230 and 3240. The axes of graph 3300, OD_i and OD_j , are used to plot optical densities at two of the many wavelengths at which measurements are obtained. The points 3301 are the measurements in the Sample Population distribution. Points 3301 are clustered within an ellipse that has been drawn to encircle the majority of points. Points 3301 inside ellipse 3302 represent measurements in the absence of Library Interferents. Point 3303 is the sample measurement. Presumably, point 3303 is outside of the spread of points 3301 due the presence of one or more Library Interferents. Lines 3304, 3307, and 3309 indicate the measurement of point 3303 as corrected for increasing concentration, T , of three different Library Interferents over the range from T_{min} to T_{max} . The three interferents of this example are referred to as interferent #1, interferent #2, and interferent #3. Specifically, lines 3304, 3307, and 3309 are obtained by subtracting from the sample measurement an amount T of a Library Interferent (interferent #1, interferent #2, and interferent #3, respectively), and plotting the corrected sample measurement for increasing T .

[0380] FIGURE 33B is a graph further illustrating the method of FIGURE 32. In the graph of FIGURE 33B, the squared Mahalanobis distance, MD^2 has been calculated and plotted as a function of t for lines 3304, 3307, and 3309. Referring to FIGURE 33A, line 3304 reflects decreasing concentrations of interferent #1 and only slightly approaches

points 3301. The value of MD^2 of line 3304, as shown in FIGURE 33B, decreases slightly and then increases with decreasing interferent #1 concentration.

[0381] Referring to FIGURE 33A, line 3307 reflects decreasing concentrations of interferent #2 and approaches or passes through many points 3301. The value of MD^2 of line 3307, as shown in FIGURE 33B, shows a large decrease at some interferent #2 concentration, then increases. Referring to FIGURE 33A, line 3309 has decreasing concentrations of interferent #3 and approaches or passes through even more points 3303. The value of MD^2 of line 3309, as shown in FIGURE 33B, shows a still larger decrease at some interferent #3 concentration.

[0382] In one embodiment, a threshold level of MD^2 is set as an indication of the presence of a particular interferent. Thus, for example, FIGURE 33B shows a line labeled "original spectrum" indicating MD^2 when no interferents are subtracted from the spectrum, and a line labeled "95% Threshold", indicating the 95% quantile for the χ^2 distribution with L degrees of freedom (where L is the number of wavelengths represented in the spectra). This level is the value which should exceed 95% of the values of the MD^2 metric; in other words, values at this level are uncommon, and those far above it should be quite rare. Of the three interferents represented in FIGURES 33A and 33B, only interferent #3 has a value of MD^2 below the threshold. Thus, this analysis of the sample indicates that interferent #3 is the most likely interferent present in the sample. Interferent #1 has its minimum far above the threshold level and is extremely unlikely to be present; interferent #2 barely crosses the threshold, making its presence more likely than interferent #1, but still far less likely to be present than interferent #1.

[0383] As described subsequently, information related to the identified interferents is used in generating a calibration constant that is relatively insensitive to a likely range of concentration of the identified interferents. In addition to being used in certain methods described subsequently, the identification of the interferents may be of interest and may be provided in a manner that would be useful. Thus, for example, for a hospital based glucose monitor, identified interferents may be reported on display 141 or be transmitted to a hospital computer via communications link 216.

CALIBRATION CONSTANT GENERATION EMBODIMENTS

[0384] Once Library Interferents are identified as being possibly present in the sample under analysis, a calibration constant for estimating the concentration of analytes in the presence of the identified interferents is generated (Block 3130). More specifically, after

Block **3120**, a list of possible Library Interferents is identified as being present. One embodiment of the steps of Block **3120** are shown in the flowchart of FIGURE 34 as Block **3410**, where synthesized Sample Population measurements are generated, Block **3420**, where the synthesized Sample Population measurements are partitioned in to calibration and test sets, Block **3430**, where the calibration are is used to generate a calibration constant, Block **3440**, where the calibration set is used to estimate the analyte concentration of the test set, Block **3450** where the errors in the estimated analyte concentration of the test set is calculated, and Block **3460** where an average calibration constant is calculated.

[0385] One embodiment of each of the methods of Blocks **3410**, **3420**, **3430**, **3440**, **3450**, and **3460** are now described for the example of using identifying interferents in a sample for generating an average calibration constant. As indicated in Block **3410**, one step is to generate synthesized Sample Population spectra, by adding a random concentration of possible Library Interferents to each Sample Population spectrum. The spectra generated by the method of Block **3410** are referred to herein as an Interferent-Enhanced Spectral Database, or IESD. The IESD can be formed by the steps illustrated in FIGURES 35-38, where FIGURE 35 is a schematic diagram **3500** illustrating the generation of Randomly-Scaled Single Interferent Spectra, or RSIS; FIGURE 36 is a graph **3600** of the interferent scaling; FIGURE 37 is a schematic diagram illustrating the combination of RSIS into Combination Interferent Spectra, or CIS; and FIGURE 38 is a schematic diagram illustrating the combination of CIS and the Sample Population spectra into an IESD.

[0386] The first step in Block **3410** is shown in FIGURES 35 and 36. As shown schematically in flowchart **3500** in FIGURE 35, and in graph **3600** in FIGURE 36, a plurality of RSIS (Block **3540**) are formed by combinations of each previously identified Library Interferent having spectrum IF_m (Block **3510**), multiplied by the maximum concentration T_{max_m} (Block **3520**) that is scaled by a random factor between zero and one (Block **3530**), as indicated by the distribution of the random number indicated in graph **3600**. In one embodiment, the scaling places the maximum concentration at the 95th percentile of a log-normal distribution to produce a wide range of concentrations with the distribution having a standard deviation equal to half of its mean value. The distribution of the random numbers in graph **3600** are a log-normal distribution of $\mu=100$, $\sigma=50$.

[0387] Once the individual Library Interferent spectra have been multiplied by the random concentrations to produce the RSIS, the RSIS are combined to produce a large

population of interferent-only spectra, the CIS, as illustrated in FIGURE 37. The individual RSIS are combined independently and in random combinations, to produce a large family of CIS, with each spectrum within the CIS consisting of a random combination of RSIS, selected from the full set of identified Library Interferents. The method illustrated in FIGURE 37 produces adequate variability with respect to each interferent, independently across separate interferents.

[0388] The next step combines the CIS and replicates of the Sample Population spectra to form the IESD, as illustrated in FIGURE 38. Since the Interferent Data and Sample Population spectra may have been obtained at different pathlengths, the CIS are first scaled (i.e., multiplied) to the same pathlength. The Sample Population database is then replicated M times, where M depends on the size of the database, as well as the number of interferents to be treated. The IESD includes M copies of each of the Sample Population spectra, where one copy is the original Sample Population Data, and the remaining M-1 copies each have an added random one of the CIS spectra. Each of the IESD spectra has an associated analyte concentration from the Sample Population spectra used to form the particular IESD spectrum.

[0389] In one embodiment, a 10-fold replication of the Sample Population database is used for 130 Sample Population spectra obtained from 58 different individuals and 18 Library Interferents. Greater spectral variety among the Library Interferent spectra requires a smaller replication factor, and a greater number of Library Interferents requires a larger replication factor.

[0390] The steps of Blocks 3420, 3430, 3440, and 3450 are executed to repeatedly combine different ones of the spectra of the IESD to statistically average out the effect of the identified Library Interferents. First, as noted in Block 3420, the IESD is partitioned into two subsets: a calibration set and a test set. As described subsequently, the repeated partitioning of the IESD into different calibration and test sets improves the statistical significance of the calibration constant. In one embodiment, the calibration set is a random selection of some of the IESD spectra and the test set are the unselected IESD spectra. In a preferred embodiment, the calibration set includes approximately two-thirds of the IESD spectra.

[0391] In an alternative embodiment, the steps of Blocks 3420, 3430, 3440, and 3450 are replaced with a single calculation of an average calibration constant using all available data.

[0392] Next, as indicated in Block 3430, the calibration set is used to generate a calibration constant for predicting the analyte concentration from a sample measurement. First an analyte spectrum is obtained. For the embodiment of glucose determined from absorption measurements, a glucose absorption spectrum is indicated as a_G . The calibration constant is then generated as follows. Using the calibration set having calibration spectra $C = \{C_1, C_2, \dots, C_n\}$ and corresponding glucose concentration values $C_j = \{g_1, g_2, \dots, g_n\}$, then glucose-free spectra $C' = \{C'_1, C'_2, \dots, C'_n\}$ can be calculated as: $C'_j = C_j - a_G g_j$. Next, the calibration constant, κ , is calculated from C' and a_G , according to the following 5 steps:

- 1) C' is decomposed into $C' = A_{C'} \Delta_{C'} B_{C'}$, that is, a singular value decomposition, where the A-factor is an orthonormal basis of column space, or span, of C' ;
- 2) $A_{C'}$ is truncated to avoid overfitting to a particular column rank r , based on the sizes of the diagonal entries of Δ (the singular values of C'). The selection of r involves a trade-off between the precision and stability of the calibration, with a larger r resulting in a more precise but less stable solution. In one embodiment, each spectrum C includes 25 wavelengths, and r ranges from 15 to 19;
- 3) The first r columns of $A_{C'}$ are taken as an orthonormal basis of $\text{span}(C')$;
- 4) The projection from the background is found as the product $P_{C'} = A_{C'} A_{C'}^T$, that is the orthogonal projection onto the span of C' , and the complementary, or nulling projection $P_{C'}^\perp = 1 - P_{C'}$, which forms the projection onto the complementary subspace C'^\perp , is calculated; and
- 5) The calibration vector κ is then found by applying the nulling projection to the absorption spectrum of the analyte of interest: $\kappa_{\text{RAW}} = P_{C'}^\perp a_G$, and normalizing: $\kappa = \kappa_{\text{RAW}} / \langle \kappa_{\text{RAW}}, a_G \rangle$, where the angle brackets \langle, \rangle denote the standard inner (or dot) product of vectors. The normalized calibration constant produces a unit response for a unit a_G spectral input for one particular calibration set.

[0393] Next, the calibration constant is used to estimate the analyte concentration in the test set (Block 3440). Specifically, each spectrum of the test set (each spectrum having an associated glucose concentration from the Sample Population spectra used to generate the test set) is multiplied by the calibration vector κ from Block 3430 to calculate an estimated glucose concentration. The error between the calculated and known

glucose concentration is then calculated (Block 3450). Specifically, the measure of the error can include a weighted value averaged over the entire test set according to $1/\text{rms}^2$.

[0394] Blocks 3420, 3430, 3440, and 3450 are repeated for many different random combinations of calibration sets. Preferably, Blocks 3420, 3430, 3440, and 3450 are repeated hundreds to thousands of times. Finally, an average calibration constant is calculated from the calibration and error from the many calibration and test sets (Block 3460). Specifically, the average calibration is computed as weighted average calibration vector. In one embodiment the weighting is in proportion to a normalized rms, such as the $\kappa_{\text{ave}} = \kappa * \text{rms}^2 / \Sigma(\text{rms}^2)$ for all tests.

[0395] With the last of Block 3130 executed according to FIGURE 34, the average calibration constant κ_{ave} is applied to the obtained spectrum (Block 3140).

[0396] Accordingly, one embodiment of a method of computing a calibration constant based on identified interferences can be summarized as follows:

1. Generate synthesized Sample Population spectra by adding the RSIS to raw (interferent-free) Sample Population spectra, thus forming an Interferent Enhanced Spectral Database (IESD) -- each spectrum of the IESD is synthesized from one spectrum of the Sample Population, and thus each spectrum of the IESD has at least one associated known analyte concentration
2. Separate the spectra of the IESD into a calibration set of spectra and a test set of spectra
3. Generate a calibration constant for the calibration set based on the calibration set spectra and their associated known correct analyte concentrations (e.g., using the matrix manipulation outlined in five steps above)
4. Use the calibration constant generated in step 3 to calculate the error in the corresponding test set as follows (repeat for each spectrum in the test set):
 - a. Multiply (the selected test set spectrum) x (average calibration constant generated in step 3) to generate an estimated glucose concentration
 - b. Evaluate the difference between this estimated glucose concentration and the known, correct glucose concentration associated with the selected test spectrum to generate an error associated with the selected test spectrum
5. Average the errors calculated in step 4 to arrive at a weighted or average error for the current calibration set - test set pair

6. Repeat steps 2 through 5 n times, resulting in n calibration constants and n average errors
7. Compute a "grand average" error from the n average errors and an average calibration constant from the n calibration constants (preferably weighted averages wherein the largest average errors and calibration constants are discounted), to arrive at a calibration constant which is minimally sensitive to the effect of the identified interferents

EXAMPLE 1

[0397] One example of certain methods disclosed herein is illustrated with reference to the detection of glucose in blood using mid-IR absorption spectroscopy. Table 2 lists 10 Library Interferents (each having absorption features that overlap with glucose) and the corresponding maximum concentration of each Library Interferent. Table 2 also lists a Glucose Sensitivity to Interferent without and with training. The Glucose Sensitivity to Interferent is the calculated change in estimated glucose concentration for a unit change in interferent concentration. For a highly glucose selective analyte detection technique, this value is zero. The Glucose Sensitivity to Interferent without training is the Glucose Sensitivity to Interferent where the calibration has been determined using the methods above without any identified interferents. The Glucose Sensitivity to Interferent with training is the Glucose Sensitivity to Interferent where the calibration has been determined using the methods above with the appropriately identified interferents. In this case, least improvement (in terms of reduction in sensitivity to an interferent) occurs for urea, seeing a factor of 6.4 lower sensitivity, followed by three with ratios from 60 to 80 in improvement. The remaining six all have seen sensitivity factors reduced by over 100, up to over 1600. The decreased Glucose Sensitivity to Interferent with training indicates that the methods are effective at producing a calibration constant that is selective to glucose in the presence of interferents.

Library Interferent	Maximum Concentration	Glucose Sensitivity to Interferent w/o training	Glucose Sensitivity to Interferent w/ training
Sodium Bicarbonate	103	0.330	0.0002
Urea	100	-0.132	0.0206
Magnesium Sulfate	0.7	1.056	-0.0016
Naproxen	10	0.600	-0.0091
Uric Acid	12	-0.557	0.0108
Salicylate	10	0.411	-0.0050
Glutathione	100	0.041	0.0003
Niacin	1.8	1.594	-0.0086
Nicotinamide	12.2	0.452	-0.0026
Chlorpropamide	18.3	0.334	0.0012

Table 2. Rejection of 10 interfering substances

EXAMPLE 2

[0398] Another example illustrates the effect of the methods for 18 interferents. Table 3 lists of 18 interferents and maximum concentrations that were modeled for this example, and the glucose sensitivity to the interferent without and with training. The table summarizes the results of a series of 1000 calibration and test simulations that were performed both in the absence of the interferents, and with all interferents present. FIGURE 39 shows the distribution of the R.M.S. error in the glucose concentration estimation for 1000 trials. While a number of substances show significantly less sensitivity (sodium bicarbonate, magnesium sulfate, tolbutamide), others show increased sensitivity (ethanol, acetoacetate), as listed in Table 3. The curves in FIGURE 39 are for calibration set and the test set both without any interferents and with all 18 interferents. The interferent produces a degradation of performance, as can be seen by comparing the calibration or test curves of FIGURE 39. Thus, for example, the peaks appear to be shifted by about 2 mg/dL, and the width of the distributions is increased slightly. The reduction in height of the peaks is due to the spreading of the distributions, resulting in a modest degradation in performance.

	Library Interferent	Conc. (mg/dL)	Glucose Sensitivity to Interferent w/o training	Glucose Sensitivity to Interferent w/ training
1	Urea	300	-0.167	-0.100
2	Ethanol	400.15	-0.007	-0.044
3	Sodium Bicarbonate	489	0.157	-0.093
4	Acetoacetate Li	96	0.387	0.601
5	Hydroxybutyric Acid	465	-0.252	-0.101
6	Magnesium Sulfate	29.1	2.479	0.023
7	Naproxen	49.91	0.442	0.564
8	Salicylate	59.94	0.252	0.283
9	Ticarcillin Disodium	102	-0.038	-0.086
10	Cefazolin	119.99	-0.087	-0.006
11	Chlorpropamide	27.7	0.387	0.231
12	Nicotinamide	36.6	0.265	0.366
13	Uric Acid	36	-0.641	-0.712
14	Ibuprofen	49.96	-0.172	-0.125
15	Tolbutamide	63.99	0.132	0.004
16	Tolazamide	9.9	0.196	0.091
17	Bilirubin	3	-0.391	-0.266
18	Acetaminophen	25.07	0.169	0.126

Table 3. List of 18 Interfering Substances with maximum concentrations and Sensitivity with respect to interferents, with/without training

EXAMPLE 3

[0399] In a third example, certain methods disclosed herein were tested for measuring glucose in blood using mid-IR absorption spectroscopy in the presence of four interferents not normally found in blood (Type-B interferents) and that may be common for patients in hospital intensive care units (ICUs). The four Type-B interferents are mannitol, dextran, n-acetyl L cysteine, and procainamide.

[0400] Of the four Type-B interferents, mannitol and dextran have the potential to interfere substantially with the estimation of glucose: both are spectrally similar to glucose (see FIGURE 1), and the dosages employed in ICUs are very large in comparison to typical glucose levels. Mannitol, for example, may be present in the blood at concentrations of 2500 mg/dL, and dextran may be present at concentrations in excess of 5000 mg/dL. For comparison, typical plasma glucose levels are on the order of 100 – 200 mg/dL. The other Type-B interferents, n-acetyl L cysteine and procainamide, have spectra that are quite unlike the glucose spectrum.

[0401] FIGURES 40A, 40B, 40C, and 40D each have a graph showing a comparison of the absorption spectrum of glucose with different interferents taken using two different techniques: a Fourier Transform Infrared (FTIR) spectrometer having an interpolated resolution of 1 cm^{-1} (solid lines with triangles); and by 25 finite-bandwidth IR filters having a Gaussian profile and full-width half-maximum (FWHM) bandwidth of 28 cm^{-1} corresponding to a bandwidth that varies from 140 nm at $7.08\text{ }\mu\text{m}$, up to 279 nm at $10\text{ }\mu\text{m}$ (dashed lines with circles). Specifically, the figures show a comparison of glucose with mannitol (FIGURE 40A), with dextran (FIGURE 40B), with n-acetyl L cysteine (FIGURE 40C), and with procainamide (FIGURE 40D), at a concentration level of 1 mg/dL and path length of $1\text{ }\mu\text{m}$. The horizontal axis in FIGURES 40A-40D has units of wavelength in microns (μm), ranging from $7\text{ }\mu\text{m}$ to $10\text{ }\mu\text{m}$, and the vertical axis has arbitrary units.

[0402] The central wavelength of the data obtained using filter is indicated in FIGURES 40A, 40B, 40C, and 40D by the circles along each dashed curve, and corresponds to the following wavelengths, in microns: 7.082, 7.158, 7.241, 7.331, 7.424, 7.513, 7.605, 7.704, 7.800, 7.905, 8.019, 8.150, 8.271, 8.598, 8.718, 8.834, 8.969, 9.099, 9.217, 9.346, 9.461, 9.579, 9.718, 9.862, and 9.990. The effect of the bandwidth of the filters on the spectral features can be seen in FIGURES 40A-40D as the decrease in the sharpness of spectral features on the solid curves and the relative absence of sharp features on the dashed curves.

[0403] FIGURE 41 shows a graph of the blood plasma spectra for 6 blood samples taken from three donors in arbitrary units for a wavelength range from $7\text{ }\mu\text{m}$ to $10\text{ }\mu\text{m}$, where the symbols on the curves indicate the central wavelengths of the 25 filters. The 6 blood samples do not contain any mannitol, dextran, n-acetyl L cysteine, and procainamide – the Type-B interferents of this Example, and are thus a Sample Population. Three donors (indicated as donor A, B, and C) provided blood at different times, resulting in different blood glucose levels, shown in the graph legend in mg/dL as measured using a YSI Biochemistry Analyzer (YSI Incorporated, Yellow Springs, OH). The path length of these samples, estimated at $36.3\text{ }\mu\text{m}$ by analysis of the spectrum of a reference scan of saline in the same cell immediately prior to each sample spectrum, was used to normalize these measurements. This quantity was taken into account in the computation of the calibration vectors provided, and the application of these vectors to spectra obtained from other equipment would require a similar pathlength estimation and normalization process to obtain valid results.

[0404] Next, random amounts of each Type-B interferent of this Example are added to the spectra to produce mixtures that, for example could make up an Interferent Enhanced Spectral. Each of the Sample Population spectra was combined with a random amount of a *single* interferent added, as indicated in Table 4, which lists an index number N, the Donor, the glucose concentration (GLU), interferent concentration (conc(IF)), and the interferent for each of 54 spectra. The conditions of Table 4 were used to form combined spectra including each of the 6 plasma spectra was combined with 2 levels of each of the 4 interferents.

N	Donor	GLU	conc(IF)	IF
1	A	157.7		N/A
2	A	382		N/A
3	B	122		N/A
4	B	477.3		N/A
5	C	199.7		N/A
6	C	399		N/A
7	A	157.7	1001.2	Mannitol
8	A	382	2716.5	Mannitol
9	A	157.7	1107.7	Mannitol
10	A	382	1394.2	Mannitol
11	B	122	2280.6	Mannitol
12	B	477.3	1669.3	Mannitol
13	B	122	1710.2	Mannitol
14	B	477.3	1113.0	Mannitol
15	C	199.7	1316.4	Mannitol
16	C	399	399.1	Mannitol
17	C	199.7	969.8	Mannitol
18	C	399	2607.7	Mannitol
19	A	157.7	8.8	N Acetyl L Cysteine
20	A	382	2.3	N Acetyl L Cysteine
21	A	157.7	3.7	N Acetyl L Cysteine
22	A	382	8.0	N Acetyl L Cysteine
23	B	122	3.0	N Acetyl L Cysteine
24	B	477.3	4.3	N Acetyl L Cysteine
25	B	122	8.4	N Acetyl L Cysteine
26	B	477.3	5.8	N Acetyl L Cysteine
27	C	199.7	7.1	N Acetyl L Cysteine
28	C	399	8.5	N Acetyl L Cysteine
29	C	199.7	4.4	N Acetyl L Cysteine

30	C	399	4.3	N Acetyl L Cysteine
31	A	157.7	4089.2	Dextran
32	A	382	1023.7	Dextran
33	A	157.7	1171.8	Dextran
34	A	382	4436.9	Dextran
35	B	122	2050.6	Dextran
36	B	477.3	2093.3	Dextran
37	B	122	2183.3	Dextran
38	B	477.3	3750.4	Dextran
39	C	199.7	2598.1	Dextran
40	C	399	2226.3	Dextran
41	C	199.7	2793.0	Dextran
42	C	399	2941.8	Dextran
43	A	157.7	22.5	Procainamide
44	A	382	35.3	Procainamide
45	A	157.7	5.5	Procainamide
46	A	382	7.7	Procainamide
47	B	122	18.5	Procainamide
48	B	477.3	5.6	Procainamide
49	B	122	31.8	Procainamide
50	B	477.3	8.2	Procainamide
51	C	199.7	22.0	Procainamide
52	C	399	9.3	Procainamide
53	C	199.7	19.7	Procainamide
54	C	399	12.5	Procainamide

Table 4. Interferent Enhanced Spectral Database for Example 3.

[0405] FIGURES 42A, 42B, 42C, and 42D contain spectra formed from the conditions of Table 4. Specifically, the figures show spectra of the Sample Population of 6 samples having random amounts of mannitol (FIGURE 42A), dextran (FIGURE 42B), n-acetyl L cysteine (FIGURE 42C), and procainamide (FIGURE 42D), at a concentration levels of 1 mg/dL and path lengths of 1 μ m.

[0406] Next, calibration vectors were generated using the spectra of FIGURES 42A-42D, in effect reproducing the steps of Block 3120. The next step of this Example is the spectral subtraction of water that is present in the sample to produce water-free spectra. As discussed above, certain methods disclosed herein provide for the estimation of an analyte concentration in the presence of interferents that are present in both a sample

population and the measurement sample (Type-A interferents), and it is not necessary to remove the spectra for interferents present in Sample Population and sample being measured. The step of removing water from the spectrum is thus an alternative embodiment of the disclosed methods.

[0407] The calibration vectors are shown in FIGURES 43A-43D for mannitol (FIGURE 43A), dextran (FIGURE 43B), n-acetyl L cysteine (FIGURE 43C), and procainamide (FIGURE 43D) for water-free spectra. Specifically each one of FIGURES 43A-43D compares calibration vectors obtained by training in the presence of an interferent, to the calibration vector obtained by training on clean plasma spectra alone. The calibration vector is used by computing its dot-product with the vector representing (pathlength-normalized) spectral absorption values for the filters used in processing the reference spectra. Large values (whether positive or negative) typically represent wavelengths for which the corresponding spectral absorbance is sensitive to the presence of glucose, while small values generally represent wavelengths for which the spectral absorbance is insensitive to the presence of glucose. In the presence of an interfering substance, this correspondence is somewhat less transparent, being modified by the tendency of interfering substances to mask the presence of glucose.

[0408] The similarity of the calibration vectors obtained for minimizing the effects of the two interferents n-acetyl L cysteine and procainamide, to that obtained for pure plasma, is a reflection of the fact that these two interferents are spectrally quite distinct from the glucose spectrum; the large differences seen between the calibration vectors for minimizing the effects of dextran and mannitol, and the calibration obtained for pure plasma, are conversely representative of the large degree of similarity between the spectra of these substances and that of glucose. For those cases in which the interfering spectrum is similar to the glucose spectrum (that is, mannitol and dextran), the greatest change in the calibration vector. For those cases in which the interfering spectrum is different from the glucose spectrum (that is, n-acetyl L cysteine and procainamide), it is difficult to detect the difference between the calibration vectors obtained with and without the interferent.

[0409] It will be understood that the steps of methods discussed are performed in one embodiment by an appropriate processor (or processors) of a processing (i.e., computer) system executing instructions (code segments) stored in appropriate storage. It will also be understood that the disclosed methods and apparatus are not limited to any particular implementation or programming technique and that the methods and apparatus

may be implemented using any appropriate techniques for implementing the functionality described herein. The methods and apparatus are not limited to any particular programming language or operating system. In addition, the various components of the apparatus may be included in a single housing or in multiple housings that communication by wire or wireless communication.

[0410] Further, the interferent, analyte, or population data used in the method may be updated, changed, added, removed, or otherwise modified as needed. Thus, for example, spectral information and/or concentrations of interferents that are accessible to the methods may be updated or changed by updating or changing a database of a program implementing the method. The updating may occur by providing new computer readable media or over a computer network. Other changes that may be made to the methods or apparatus include, but are not limited to, the adding of additional analytes or the changing of population spectral information.

[0411] One embodiment of each of the methods described herein may include a computer program accessible to and/or executable by a processing system, e.g., a one or more processors and memories that are part of an embedded system. Thus, as will be appreciated by those skilled in the art, embodiments of the disclosed inventions may be embodied as a method, an apparatus such as a special purpose apparatus, an apparatus such as a data processing system, or a carrier medium, e.g., a computer program product. The carrier medium carries one or more computer readable code segments for controlling a processing system to implement a method. Accordingly, various ones of the disclosed inventions may take the form of a method, an entirely hardware embodiment, an entirely software embodiment or an embodiment combining software and hardware aspects. Furthermore, any one or more of the disclosed methods (including but not limited to the disclosed methods of measurement analysis, interferent determination, and/or calibration constant generation) may be stored as one or more computer readable code segments or data compilations on a carrier medium. Any suitable computer readable carrier medium may be used including a magnetic storage device such as a diskette or a hard disk; a memory cartridge, module, card or chip (either alone or installed within a larger device); or an optical storage device such as a CD or DVD.

[0412] In view of the foregoing, certain disclosed embodiments comprise an apparatus for analyzing the composition of bodily fluid. This apparatus includes a first fluid passageway, at least one pump, an analyte detection system, and a fluid sensor.

[0413] The first fluid passageway (such as, without limitation, the passageway 112 and/or the passageway 113) has a patient end configured to provide fluid communication with a bodily fluid within a patient. Where the first fluid passageway comprises the passageway 112, the patient end can comprise the end or region of the passageway 112 which is nearest the patient P, such as the patient connector 110/1100/1200, or any other suitable interface with any intervening fluid passageways or fluid network between the first fluid passageway and the patient P. Alternatively the patient end can comprise the connector 230; or the end of the connector 110 opposite the apparatus 140; or the end of the sampling assembly 220 adjacent the connector 1100/1200 when employed as shown in FIGURES 11 or 12. The patient end of the first fluid passageway of certain embodiments can provide the apparatus with fluid communication to the bodily fluid within the patient indirectly, where an intervening tube or passageway, such as the catheter 11, I.V. tubing, or other fluid handling apparatus, is positioned between the first fluid passageway and the patient to provide a fluid handling link between the patient and the first fluid passageway.

[0414] In some embodiments the apparatus also includes a second fluid passageway (such as, without limitation, the passageway 113) in fluid communication with the first fluid passageway via a junction between the first and second fluid passageways with the fluid sensor configured to sense the arrival of bodily fluid near the junction of the first and second fluid passageways. Thus, in several embodiments, the junction of the first and second fluid passageways can be the junction of the passageways 112 and 113 as depicted in any of FIGURES 3, 5, 6A, 6B, 7A-7J, or 9.

[0415] The at least one pump is coupled to the first fluid passageway and has an infusion mode and a sample draw mode. In the infusion mode (an example of which is described herein in reference to FIGURE 7A), the pump is operable to deliver infusion fluid to the patient through the patient end of the first fluid passageway. In the sample draw mode (an example of which is described herein in reference to FIGURE 7C), the pump is operable to draw a sample of the bodily fluid from the patient through the patient end of the first fluid passageway. The at least one pump can comprise any of the pumps discussed herein, including pumps 203 and 328, pump roller 1005a, and displacement pump 905. In certain embodiments, the apparatus comprises at least one pump having both the infusion mode and the sample draw modes. In certain other embodiments, the at least one pump of the apparatus comprises two unidirectional or single-mode pumps, wherein one

unidirectional or single-mode pump provides the infusion mode and a second unidirectional or single-mode pump provides the sample draw mode.

[0416] The analyte detection system is accessible via the first fluid passageway such that the analyte detection system can receive at least one component of the drawn sample of bodily fluid and determine the concentration of at least one analyte. For example, in certain embodiments, the analyte detection system receives the bodily fluid (e.g., blood) in its whole state and determines the concentration of at least one analyte. For another example, in certain embodiments, the analyte detection system receives plasma (a component) separated from a whole blood drawn sample and determines the concentration of at least one analyte. In certain embodiments, the analyte detection system determines the analyte concentration in the component under analysis, in the drawn sample, in the patient, or in a combination of one or more of the component, drawn sample, and patient. The analyte detection system is generally positioned at a distance (e.g., one foot to eight feet), from the patient end of the first fluid passageway. Some embodiments of the analyte detection system include analyte detection systems 334 and 1700, described herein. Alternatively, the analyte detection system can comprise any suitable optical, spectroscopic, enzymatic (e.g. glucose), reagent-based (e.g., TPH or heart condition markers), and/or electrochemical (e.g., pH) analyte detection system.

[0417] The fluid sensor is located at or near the patient end of the first fluid passageway and spaced from the analyte detection system. The fluid sensor is configured to sense a property of the fluid within the first fluid passageway. In some embodiments, the fluid sensor is located between the patient end of the first fluid passageway and the analyte detection system. In various embodiments, the fluid sensor can comprise a colorimetric sensor, a hemoglobin sensor, a hematocrit sensor, a pressure sensor, a bubble sensor, a dilution sensor, or a combination thereof. Examples of such sensors are discussed herein, including colorimetric sensor 311, hemoglobin sensor 1003, pressure sensors and sensor units 317, 507, 1011, and 1102, and bubble sensors and sensor units 314a, 314b, 321, 505, 1001a, 1001b, and 1001c. A dilution sensor compatible with certain embodiments described herein provides a signal indicative of the dilution of the fluid within the first fluid passageway. In certain embodiments, this signal from the dilution sensor is used to indicate that the system can discontinue drawing body fluid from the patient and can draw a sample of the body fluid to the analyzer. The fluid sensor of certain embodiments is useful for detecting the arrival of body fluid in the first fluid passageway, or for identifying the type

and/or condition of the fluid in proximity to the fluid sensor to facilitate directing the fluid to one or more appropriate locations in the system. For example, in certain embodiments, one or more signals from the fluid sensor are used to indicate that the system can discontinue drawing body fluid from the patient and can draw a sample of the body fluid to the analyzer, thereby facilitating directing a drawn blood sample to the analyte detection system for subsequent analysis of one or more desired blood analytes, as discussed herein. In some embodiments, the fluid sensor is located in a near-patient module (e.g., the patient connector 110 or the sampling assembly 220) located on the first fluid passageway between the patient end and the analyte detection system. The near-patient module can be spaced from the analyte detection system.

[0418] Certain disclosed embodiments comprise fluid-handling methods which are executable with, for example, any of the embodiments described above of the apparatus for analyzing the compositions of bodily fluid. Certain such methods include providing a first fluid passageway and an analyte detection system, infusing an infusion fluid to a patient, drawing or otherwise obtaining a body fluid from the patient, sensing a property of fluid within the first fluid passageway, and determining a concentration of at least one analyte in the fluid within the first fluid passageway. The first fluid passageway has a patient end and provides access to the analyte detection system. The infusion fluid is infused to the patient through the patient end, and the body fluid is drawn from the patient through the patient end. Properties of the fluid within the first fluid passageway are sensed at a sensing location at or near the patient end and spaced from the analyte detection system. In certain embodiments, the fluid within the first fluid passageway comprises the body fluid alone, while in other embodiments, the fluid within the first fluid passageway comprises the body fluid mixed with another fluid (e.g., infusion fluid). In some embodiments, the fluid-handling method further comprises providing a second fluid passageway in fluid communication with the first fluid passageway via a junction between the first and second passageways and sensing the arrival of the body fluid near the junction of the first and second fluid passageways.

[0419] In various embodiments, sensing a property of the fluid within the first fluid passageway comprises sensing the color, the hemoglobin content, the hematocrit, the dilution, the pressure of the fluid within the first fluid passageway, the presence of one or more bubbles in the first fluid passageway, detecting the arrival of body fluid in the first fluid passageway, or a combination thereof. In certain embodiments, sensing a property of

the fluid within the first fluid passageway comprises sensing a property of the infusion fluid or the body fluid within the first fluid passageway. In certain embodiments, determining the concentration of at least one analyte in the fluid within the first fluid passageway comprises determining the concentration of at least one analyte in at least one component of the body fluid. In certain embodiments, the property of the fluid within the first fluid passageway is sensed by a fluid sensor, which can be located at or near the patient end of the first fluid passageway, or on the first fluid passageway between the patient end and the analyte detection system.

[0420] Other disclosed embodiments comprise a sampling assembly to be used with a main analyzer (such as, without limitation, the fluid handling and analysis apparatus 140 or the analyte detection system 334) which is configured to sense an analyte in a body fluid drawn or otherwise obtained from a patient through a first fluid passageway (e.g., the passageway 112 and/or the passageway 113). The first fluid passageway extends from the main analyzer toward the patient. The assembly (which, in certain embodiments can comprise the sampling assembly 220 or the patient connector 110) includes an instrument portion (such as, without limitation, the instrument portion 813 or a sensing module). The instrument portion includes at least one sensor and is preferably separate from the main analyzer and removably engaged with the first fluid passageway. The at least one sensors of the instrument portion is in sensing engagement with the first fluid passageway such that the at least one sensors can sense a property of a fluid within the first fluid passageway.

[0421] Still other disclosed embodiments comprise a body fluid analysis system including a main analyzer (such as, without limitation, the fluid handling and analysis apparatus 140 or the analyte detection system 334) and a sampling assembly (e.g., the sampling assembly 220 or the patient connector 110). The main analyzer is configured to measure an analyte in a sample of body fluid drawn or otherwise obtained from a patient, or in one or more components of such a drawn sample of body fluid. The sampling assembly is in communication with the main analyzer and includes a first fluid passageway (such as, without limitation, the passageway 112 and/or the passageway 113) and an instrument portion or sensing module (which, in one embodiment, can comprise the instrument portion 813). The first fluid passageway extends from the main analyzer and has a patient end spaced from the main analyzer. The instrument portion is removably engaged with the first fluid passageway and is located on the first fluid passageway spaced from the main

analyzer. The instrument portion has at least one sensor in sensing engagement with the first fluid passageway.

[0422] Other disclosed embodiments comprise a sampling assembly for use with a main analyzer (such as, without limitation, the fluid handling and analysis apparatus 140 or analyte detection system 334) which is configured to sense an analyte in a body fluid drawn or otherwise obtained from a patient through a first fluid passageway (e.g., the passageway 112 and/or the passageway 113). The first fluid passageway has a patient end located at a distance from the main analyzer and an interface region where the first fluid passageway meets the main analyzer. The sampling assembly (such as, without limitation, the sampling assembly 220 or the patient connector 110) includes an instrument portion or sensing module (which can comprise the instrument portion 813) which includes at least one sensor and is removably engaged with the first fluid passageway between the patient end and the interface region of the first fluid passageway. The sensor engages the first fluid passageway such that it can sense a property of a fluid within the first fluid passageway. In certain embodiments, the fluid within the first fluid passageway comprises the body fluid alone while in other embodiments, the fluid within the first fluid passageway comprises the body fluid mixed with another fluid (e.g., the infusion fluid).

[0423] In some embodiments, the sampling assemblies disclosed above can also include a second fluid passageway (such as, without limitation, the passageway 113) in fluid communication with the first fluid passageway via a passageway junction (e.g., the junction 829). The instrument portion or the sampling assembly removably engages both the first and second fluid passageways at or near the passageway junction. One or more of the at least one sensor of the instrument portion or the sampling assembly can be located between the passageway junction and a patient end of the first fluid passageway, or between the junction and the interface region of the passageway.

[0424] The at least one sensor of the sampling assemblies discussed above can comprise any one or more of the following, in various embodiments: dilution sensor, colorimetric sensor 311, hemoglobin sensor 1003, pressure sensors and sensor units 317, 507, 1011, and 1102, and bubble sensors and sensor units 314a, 314b, 505, 1001b, and 1001c. The at least one sensor can be configured to detect the arrival of, or a property of, drawn body fluid in the first fluid passageway, or to identify the type and/or condition of the fluid next to the fluid sensor to facilitate directing the fluid to the appropriate location

or locations in the system for, e.g., subsequent analysis of one or more desired blood analytes in the analyte detection system, as discussed herein.

[0425] The junction of the first and second fluid passageways of the above-described embodiments of the sampling assembly or body fluid analysis system can be the junction of the passageways 112 and 113 as depicted in any of FIGURES 3, 5, 6A, 6B, 7A-7J, or 9.

[0426] Where the first fluid passageway comprises the passageway 112, the patient end can comprise the end or region of the passageway 112 which is nearest the patient P, such as the patient connector 110/1100/1200, or any other suitable interface with any intervening fluid passageways or fluid network between the first fluid passageway and the patient P. Alternatively the patient end can comprise the connector 230; or the end of the connector 110 opposite the apparatus 140; or the end of the sampling assembly 220 adjacent the connector 1100/1200 when employed as shown in FIGURES 11 or 12. The patient end of the first fluid passageway can provide fluid communication with the bodily fluid within the patient indirectly, where an intervening tube or passageway, such as the catheter 11, I.V. tubing, or other fluid handling apparatus, is positioned between the first fluid passageway and the patient to provide a fluid handling link between the patient and the first fluid passageway.

[0427] The instrument portion, in some embodiments of the sampling assembly or body fluid analysis system discussed above, can include at least one first valve portion (such as, without limitation, 312, 313, 316, and/or 613) in operative engagement with the first fluid passageway. An instrument portion including such a first valve portion can also include a second valve portion (such as, without limitation, 312, 313, 316, and/or 613) in operative engagement with a second fluid passageway connected to the first fluid passageway.

[0428] Certain disclosed embodiments comprise methods of handling body fluid which are executable with, for example, any of the embodiments described above of the sampling assembly or body fluid analysis system. In certain embodiments, the body fluid is within a first fluid passageway extending from and in fluid communication with a main analyzer. In certain embodiments, a method includes removably engaging the first fluid passageway with a sensing module separate from the main analyzer and sensing a property of the body fluid within the first fluid passageway with at least one sensor of the sensing module. In some embodiments the method further includes injecting gas into the first fluid

passageway or a second fluid passageway in fluid communication with the first fluid passageway using the sensing module. In some embodiments the method includes directing the body fluid from the first fluid passageway into a second fluid passageway using the sensing module. Some embodiments further include directing the body fluid with at least one valve portion of the sensing module. In some embodiments, sensing includes sensing the arrival of the body fluid in the first fluid passageway. In various embodiments, sensing comprises sensing the color, the hemoglobin content, the hematocrit, the dilution, and/or the pressure of the body fluid; and/or sensing the presence of bubbles in the first fluid passageway.

[0429] One advantage of some embodiments of the apparatus and methods disclosed herein (including the sampling assembly 220 and patient connector 100, and methods of use thereof) is limiting blood damage. More particularly, when a sample or volume of blood is drawn or otherwise obtained from the patient for sensing by the one or more sensors of the sampling assembly or instrument portion, the sample passes through the passageway 112 from the patient end to reach the instrument portion, where it is stopped, preferably well short of the analyte detection system 334 or apparatus 140. At least a first portion of this initial sample is then diverted and passed along to the system 334 or apparatus 140 for analysis, and a second portion (e.g., having a volume larger than a volume of the first portion) is returned to the patient via the passageway 112 (e.g., by one or more valves). In certain embodiments in which this returned blood travels only a relatively short distance to the sampling assembly 220 or patient connector 110 (e.g., where the distance traveled by the second portion is shorter than the distance traveled by the first portion), rather than all the way to the system 334 or apparatus 140, damage to the returned blood is diminished. For example, this returned blood is much less likely to coagulate or to have lysed (incurred damage to the red blood cells) as a result of the shorter distance traveled in returning to the patient. Limiting coagulation prevents the formation of clots which can restrict the flow of blood, and maintaining the integrity of red blood cells prevents loss of the blood's oxygen transport functions. These benefits result in overall improved status of the patient as compared to patients analyzed by systems that require returning blood to travel longer distances (e.g. all the way to the analyte detection system and back to the patient). Accordingly, certain of the above-described apparatus and methods can be considered apparatus and methods for limiting damage to returned blood.

[0430] Reference throughout this specification to “one embodiment” or “an embodiment” means that a particular feature, structure or characteristic described in connection with the embodiment is included in at least one embodiment. Thus, appearances of the phrases “in one embodiment” or “in an embodiment” in various places throughout this specification are not necessarily all referring to the same embodiment. Furthermore, the particular features, structures or characteristics may be combined in any suitable manner, as would be apparent to one of ordinary skill in the art from this disclosure, in one or more embodiments.

[0431] Similarly, it should be appreciated that in the above description of embodiments, various features of the inventions are sometimes grouped together in a single embodiment, figure, or description thereof for the purpose of streamlining the disclosure and aiding in the understanding of one or more of the various inventive aspects. This method of disclosure, however, is not to be interpreted as reflecting an intention that any claim require more features than are expressly recited in that claim. Rather, as the following claims reflect, inventive aspects lie in a combination of fewer than all features of any single foregoing disclosed embodiment. Thus, the claims following the Detailed Description are hereby expressly incorporated into this Detailed Description, with each claim standing on its own as a separate embodiment.

[0432] Further information on analyte detection systems, sample elements, algorithms and methods for computing analyte concentrations, and other related apparatus and methods can be found in U.S. Patent Application Publication No. 2003/0090649, published May 15, 2003, titled REAGENT-LESS WHOLE BLOOD GLUCOSE METER; U.S. Patent Application Publication No. 2003/0178569, published September 25, 2003, titled PATHLENGTH-INDEPENDENT METHODS FOR OPTICALLY DETERMINING MATERIAL COMPOSITION; U.S. Patent Application Publication No. 2004/0019431, published January 29, 2004, titled METHOD OF DETERMINING AN ANALYTE CONCENTRATION IN A SAMPLE FROM AN ABSORPTION SPECTRUM; U.S. Patent Application Publication No. 2005/0036147, published February 17, 2005, titled METHOD OF DETERMINING ANALYTE CONCENTRATION IN A SAMPLE USING INFRARED TRANSMISSION DATA; and U.S. Patent Application Publication No. 2005/0038357, published on February 17, 2005, titled SAMPLE ELEMENT WITH BARRIER MATERIAL. The entire contents of each of the above-mentioned publications are hereby incorporated by reference herein and are made a part of this specification.

[0433] A number of applications, publications and external documents are incorporated by reference herein. Any conflict or contradiction between a statement in the bodily text of this specification and a statement in any of the incorporated documents is to be resolved in favor of the statement in the bodily text.

[0434] Although the invention(s) presented herein have been disclosed in the context of certain preferred embodiments and examples, it will be understood by those skilled in the art that the invention(s) extend beyond the specifically disclosed embodiments to other alternative embodiments and/or uses of the invention(s) and obvious modifications and equivalents thereof. Thus, it is intended that the scope of the invention(s) herein disclosed should not be limited by the particular embodiments described above, but should be determined only by a fair reading of the claims that follow.

WHAT IS CLAIMED IS:

1. A sampling assembly for use with a main analyzer which is configured to sense an analyte in a body fluid obtained from a patient through a first fluid passageway extending from said main analyzer, said sampling assembly comprising:

an instrument portion separate from said main analyzer and comprising at least one sensor, said instrument portion being removably engaged with said first fluid passageway, said at least one sensor being in sensing engagement with said first fluid passageway such that said at least one sensor can sense a property of a fluid within said first fluid passageway.

2. The assembly of Claim 1, wherein said fluid within said first fluid passageway comprises said body fluid.

3. The assembly of Claim 1, wherein a second fluid passageway is in fluid communication with said first fluid passageway via a passageway junction, said instrument portion removably engaging both said first and second fluid passageways at or near said passageway junction.

4. The assembly of Claim 1, wherein said at least one sensor is configured to detect the arrival of said body fluid in said first fluid passageway.

5. The assembly of Claim 1, wherein said at least one sensor comprises a colorimetric sensor.

6. The assembly of Claim 1, wherein said at least one sensor comprises a hemoglobin sensor.

7. The assembly of Claim 1, wherein said at least one sensor comprises a hematocrit sensor.

8. The assembly of Claim 1, wherein said at least one sensor comprises a pressure sensor.

9. The assembly of Claim 1, wherein said at least one sensor comprises a bubble sensor.

10. The assembly of Claim 1, wherein said at least one sensor comprises a dilution sensor.

11. The assembly of Claim 1, wherein said instrument portion further comprises at least one first valve portion in operative engagement with said first fluid passageway.

12. The assembly of Claim 10, further comprising a second fluid passageway in fluid communication with said first fluid passageway, wherein said instrument portion further comprises a second valve portion in operative engagement with said second fluid passageway.

13. The assembly of Claim 2, wherein at least one sensor of the instrument portion is located between said passageway junction and a patient end of said first fluid passageway.

14. A sampling assembly for use with a main analyzer which is configured to sense an analyte in a body fluid obtained from a patient through a first fluid passageway having a patient end spaced from said main analyzer and an interface region where said first fluid passageway meets said main analyzer, said sampling assembly comprising:

an instrument portion comprising at least one sensor, said instrument portion being removably engaged with said first fluid passageway between said patient end and said interface region, said at least one sensor being in sensing engagement with said first fluid passageway such that said at least one sensor can sense a property of a fluid contained in said first fluid passageway.

15. The assembly of Claim 14, wherein said fluid contained in said first fluid passageway comprises said body fluid.

16. The assembly of Claim 14, wherein a second fluid passageway is in fluid communication with said first fluid passageway via a passageway junction, said instrument portion removably engaging both said first and second fluid passageways at said passageway junction.

17. The assembly of Claim 14, wherein said at least one sensor is configured to detect the arrival of said body fluid in said first fluid passageway.

18. The assembly of Claim 14, wherein said at least one sensor comprises a colorimetric sensor.

19. The assembly of Claim 14, wherein said at least one sensor comprises a hemoglobin sensor.

20. The assembly of Claim 14, wherein said at least one sensor comprises a hematocrit sensor.

21. The assembly of Claim 14, wherein said at least one sensor comprises a pressure sensor.

22. The assembly of Claim 14, wherein said at least one sensor comprises a bubble sensor.

23. The assembly of Claim 14, wherein said at least one sensor comprises a dilution sensor.

24. The assembly of Claim 14, wherein said instrument portion further comprises at least one first valve portion in operative engagement with said first fluid passageway.

25. The assembly of Claim 23, further comprising a second fluid passageway in fluid communication with said first fluid passageway, wherein said instrument portion further comprises a second valve portion in operative engagement with said second fluid passageway.

26. The assembly of Claim 15, wherein said at least one sensor is located between said passageway junction and a patient end of said first fluid passageway.

27. A body fluid analysis system comprising:
a main analyzer configured to measure an analyte in a sample of body fluid obtained from a patient; and

a sampling assembly in communication with said main analyzer, said sampling assembly comprising:

a first fluid passageway extending from said main analyzer, said first fluid passageway having a patient end spaced from said main analyzer; and

an instrument portion removably engaged with said first fluid passageway and located on said first fluid passageway spaced from said main analyzer, said instrument portion having at least one sensor in sensing engagement with said first fluid passageway.

28. The assembly of Claim 27, wherein a second fluid passageway is in fluid communication with said first fluid passageway via a passageway junction, said instrument portion removably engaging both said first and second fluid passageways at or near said passageway junction.

29. The assembly of Claim 27, wherein at least one of said at least one sensor is configured to detect the arrival of said body fluid in said first fluid passageway.

30. The assembly of Claim 27, wherein said at least one sensor comprises a colorimetric sensor.

31. The assembly of Claim 27, wherein said at least one sensor comprises a hemoglobin sensor.

32. The assembly of Claim 27, wherein said at least one sensor comprises a hematocrit sensor.

33. The assembly of Claim 27, wherein said at least one sensor comprises a pressure sensor.

34. The assembly of Claim 27, wherein said at least one sensor comprises a bubble sensor.

35. The assembly of Claim 27, wherein said at least one sensor comprises a dilution sensor.

36. The assembly of Claim 27, wherein said instrument portion further comprises at least one first valve portion in operative engagement with said first fluid passageway.

37. The assembly of Claim 35, further comprising a second fluid passageway in fluid communication with said first fluid passageway, wherein said instrument portion further comprises a second valve portion in operative engagement with said second fluid passageway.

38. The assembly of Claim 28, wherein at least one of said at least one sensor is located between said passageway junction and a patient end of said first fluid passageway.

39. A method of handling body fluid within a first fluid passageway which extends from and is in fluid communication with a main analyzer, said method comprising:

removably engaging said first fluid passageway with a sensing module separate from said main analyzer; and

with at least one sensor of said sensing module, sensing a property of a fluid within said first fluid passageway.

40. The method of Claim 39, wherein said sensing comprises sensing the arrival of said fluid in said first fluid passageway.

41. The method of Claim 39, wherein said sensing comprises sensing the color of said fluid in said first fluid passageway.

42. The method of Claim 39, wherein said sensing comprises sensing the hemoglobin content of said fluid in said first fluid passageway.

43. The method of Claim 39, wherein said sensing comprises sensing the hematocrit of said fluid in said first fluid passageway.

44. The method of Claim 39, wherein said sensing comprises sensing the pressure of said fluid in said first fluid passageway.

45. The method of Claim 39, wherein said sensing comprises sensing the presence of one or more bubbles in said first fluid passageway.

46. The method of Claim 39, wherein said sensing comprises sensing dilution of said fluid in said first fluid passageway.

47. The method of Claim 39, further comprising directing said body fluid from said first fluid passageway into a second fluid passageway using said sensing module.

48. The method of Claim 46, wherein said directing comprises directing with at least one valve portion of said sensing module.

49. The method of Claim 39, further comprising injecting gas into said first fluid passageway or a second fluid passageway in fluid communication with said first fluid passageway using said sensing module.

50. The method of Claim 39, wherein said fluid within said first fluid passageway comprises said body fluid.

51. An apparatus for analyzing the composition of bodily fluid, said apparatus comprising:

a first fluid passageway having a patient end which is configured to provide fluid communication with a bodily fluid within a patient;

at least one pump coupled to said first fluid passageway, said at least one pump having an infusion mode in which said pump is operable to deliver infusion fluid to said patient through said patient end, and a sample draw mode in which said pump is operable to draw a sample of said bodily fluid from said patient through said patient end;

an analyte detection system accessible via said first fluid passageway such that said analyte detection system can receive at least one component of said drawn sample of bodily fluid, and determine a concentration of at least one analyte, said analyte detection system being spaced from said patient end of said first fluid passageway; and

a fluid sensor located at or near said patient end of said first fluid passageway and spaced from said analyte detection system, said fluid sensor being configured to sense a property of a fluid within said first fluid passageway.

52. The apparatus of Claim 51, wherein said analyte detection system comprises an optical analyte detection system.

53. The apparatus of Claim 51, wherein said analyte detection system comprises a spectroscopic analyte detection system.

54. The apparatus of Claim 51, wherein said analyte detection system comprises an electromechanical analyte detection system.

55. The apparatus of Claim 51, wherein said analyte detection system comprises an enzymatic analyte detection system.

56. The apparatus of Claim 51, wherein said analyte detection system comprises a reagent-based analyte detection system.

57. The apparatus of Claim 51, wherein said fluid sensor is located between said patient end and said analyte detection system.

58. The apparatus of Claim 51, wherein said fluid sensor comprises a colorimetric sensor.

59. The apparatus of Claim 51, wherein said fluid sensor comprises a hemoglobin sensor.

60. The apparatus of Claim 51, wherein said fluid sensor comprises a hematocrit sensor.

61. The apparatus of Claim 51, wherein said fluid sensor comprises a pressure sensor.

62. The apparatus of Claim 51, wherein said fluid sensor comprises a bubble sensor.

63. The apparatus of Claim 51, wherein said fluid sensor comprises a dilution sensor.

64. The apparatus of Claim 51, wherein said fluid sensor is configured to detect the arrival of said drawn sample of bodily fluid in said first fluid passageway.

65. The apparatus of Claim 51, wherein said fluid sensor is located in a near-patient module located on said first fluid passageway between said patient end and said analyte detection system.

66. The apparatus of Claim 65, wherein said near-patient module is spaced from said analyte detection system.

67. The apparatus of Claim 51, further comprising a second fluid passageway in fluid communication with said first fluid passageway via a junction between the first and second passageways, wherein said fluid sensor is configured to sense the arrival of said drawn sample of bodily fluid near said junction between said first and second fluid passageways.

68. The apparatus of Claim 51, wherein said at least one pump comprises a first single-mode pump operable in said infusion mode and a second single-mode pump operable in said sample draw mode.

69. A fluid-handling method comprising:
providing a first fluid passageway having a patient end and a spectroscopic analyte detection system accessible via said first fluid passageway;
infusing an infusion fluid through said patient end;
drawing a body fluid through said patient end;
sensing a property of a fluid within said first fluid passageway at a sensing location at or near said patient end and spaced from said analyte detection system;
and
determining the concentration of at least one analyte in the fluid within said first fluid passageway using said analyte detection system.

70. The method of Claim 69, wherein said fluid within said first fluid passageway comprises the body fluid.

71. The method of Claim 69, wherein said sensing comprises sensing the color of the fluid within said first fluid passageway.

72. The method of Claim 69, wherein said sensing comprises sensing the hemoglobin content of the fluid within said first fluid passageway.

73. The method of Claim 69, wherein said sensing comprises sensing the hematocrit of the fluid within said first fluid passageway.

74. The method of Claim 69, wherein said sensing comprises sensing the pressure of the fluid within said first fluid passageway.

75. The method of Claim 69, wherein said sensing comprises sensing the presence of one or more bubbles within said first fluid passageway.

76. The method of Claim 69, wherein said sensing comprises sensing dilution of said fluid within said first fluid passageway.

77. The method of Claim 69, wherein said sensing comprises detecting the arrival of said fluid within said first fluid passageway.

78. The method of Claim 69, further comprising providing a second fluid passageway in fluid communication with said first fluid passageway via a junction between the first and second passageways and sensing the arrival of said body fluid near said junction of said first and second fluid passageways.

79. The method of Claim 69, wherein sensing a property of said fluid within said first fluid passageway comprises sensing a property of said infusion fluid or said body fluid within said first fluid passageway.

80. The method of Claim 69, wherein determining the concentration of at least one analyte in said fluid within said first fluid passageway comprises determining the concentration of at least one analyte in at least one component of said body fluid.

81. A method for analyzing the composition of a body fluid, said method comprising:

obtaining a body fluid sample from a patient end of a first fluid passageway;

passing said sample through said first fluid passageway towards an analyte detection system;

detecting a property of said sample at a location along said first fluid passageway;

separating the sample into a first portion and a second portion;

passing said first portion to said analyte detection system; and

returning said second portion through said patient end of said first fluid passageway.

82. The method of Claim 81, wherein said first portion travels a first distance to said analyte detection system and said second portion travels a second distance to said patient end, wherein said second distance is smaller than said first distance.

83. A system for obtaining a body fluid sample, said system comprising:

a first fluid passageway having a patient end which is configured to provide fluid communication with a body fluid of a patient;

a sensor located at a predetermined location along said first fluid passageway, wherein said sensor is configured to detect a property of fluid within said first fluid passageway; and

an analyte detection system in fluid communication with said first fluid passageway, wherein at least a first portion of said fluid within said first fluid passageway at said predetermined location travels a first distance to said analyte detection system and at least a second portion of said fluid within said first fluid passageway at said predetermined location travels a second distance to said patient.

84. The system of Claim 83, wherein said second distance is smaller than said first distance.

85. The system of Claim 83, further comprising one or more valves configured to direct fluid within said first fluid passageway into at least said first portion and at least said second portion.

86. The system of Claim 83, wherein a volume of said first portion is smaller than a volume of said second portion.

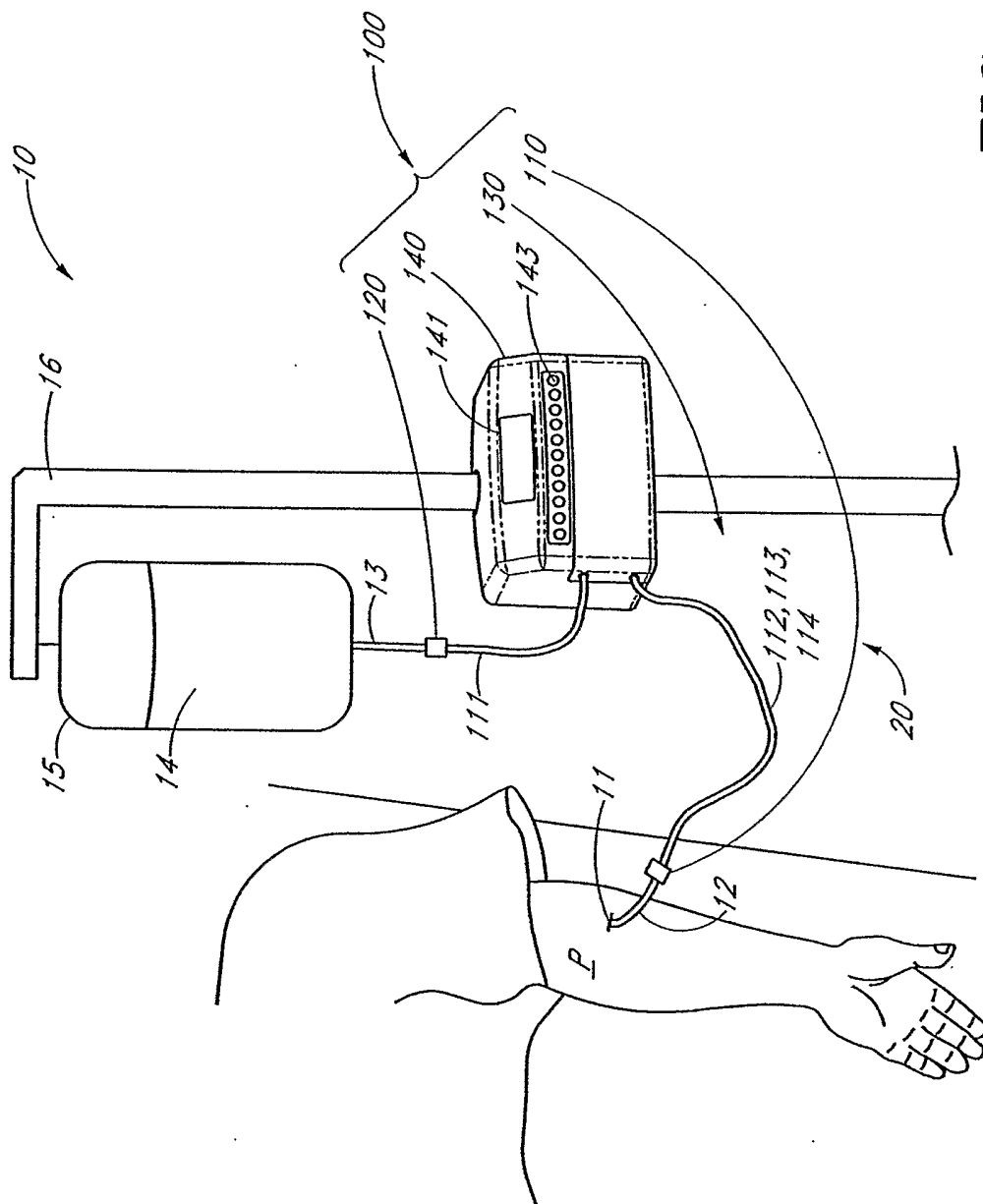

FIG. 1

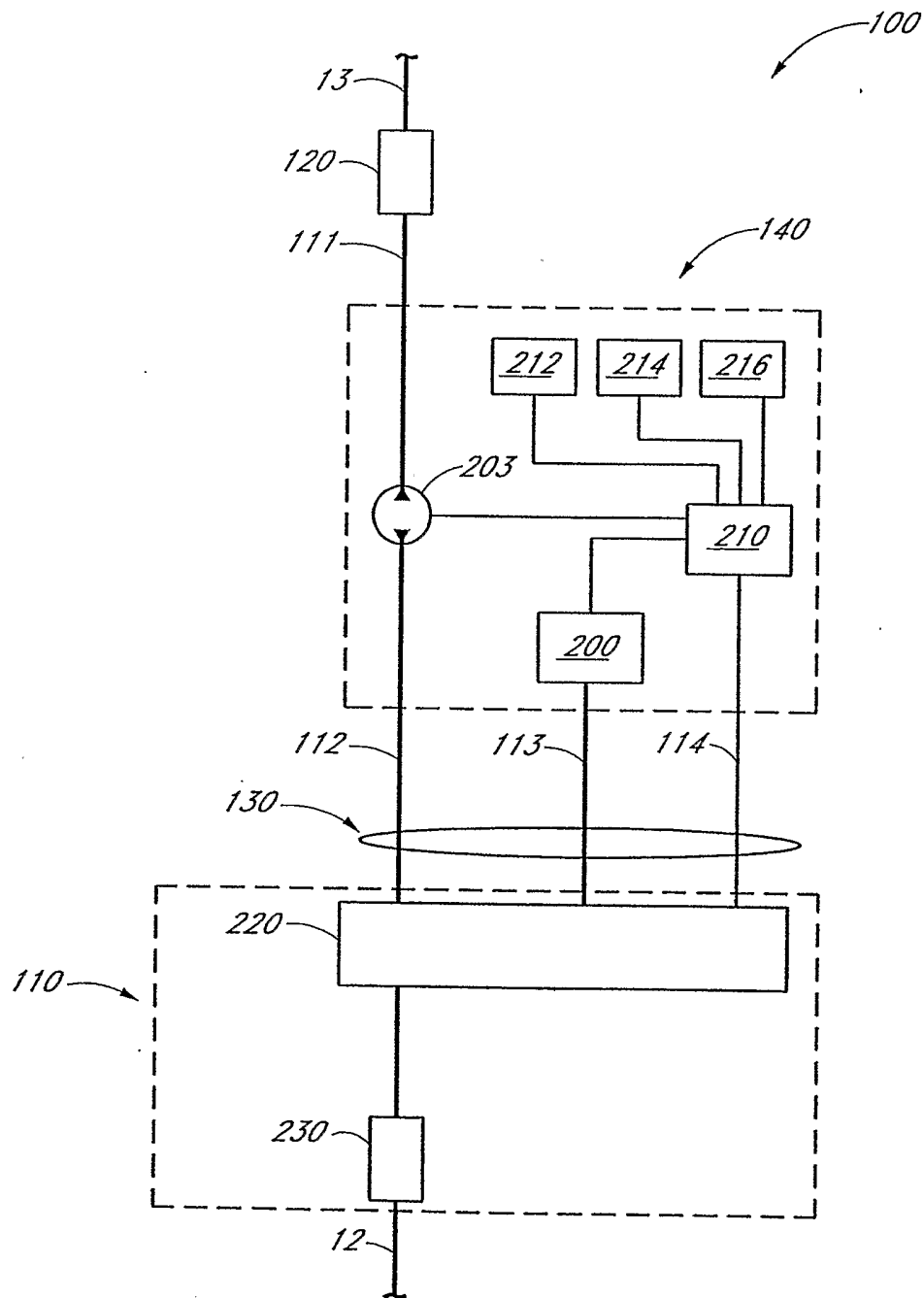

FIG. 2

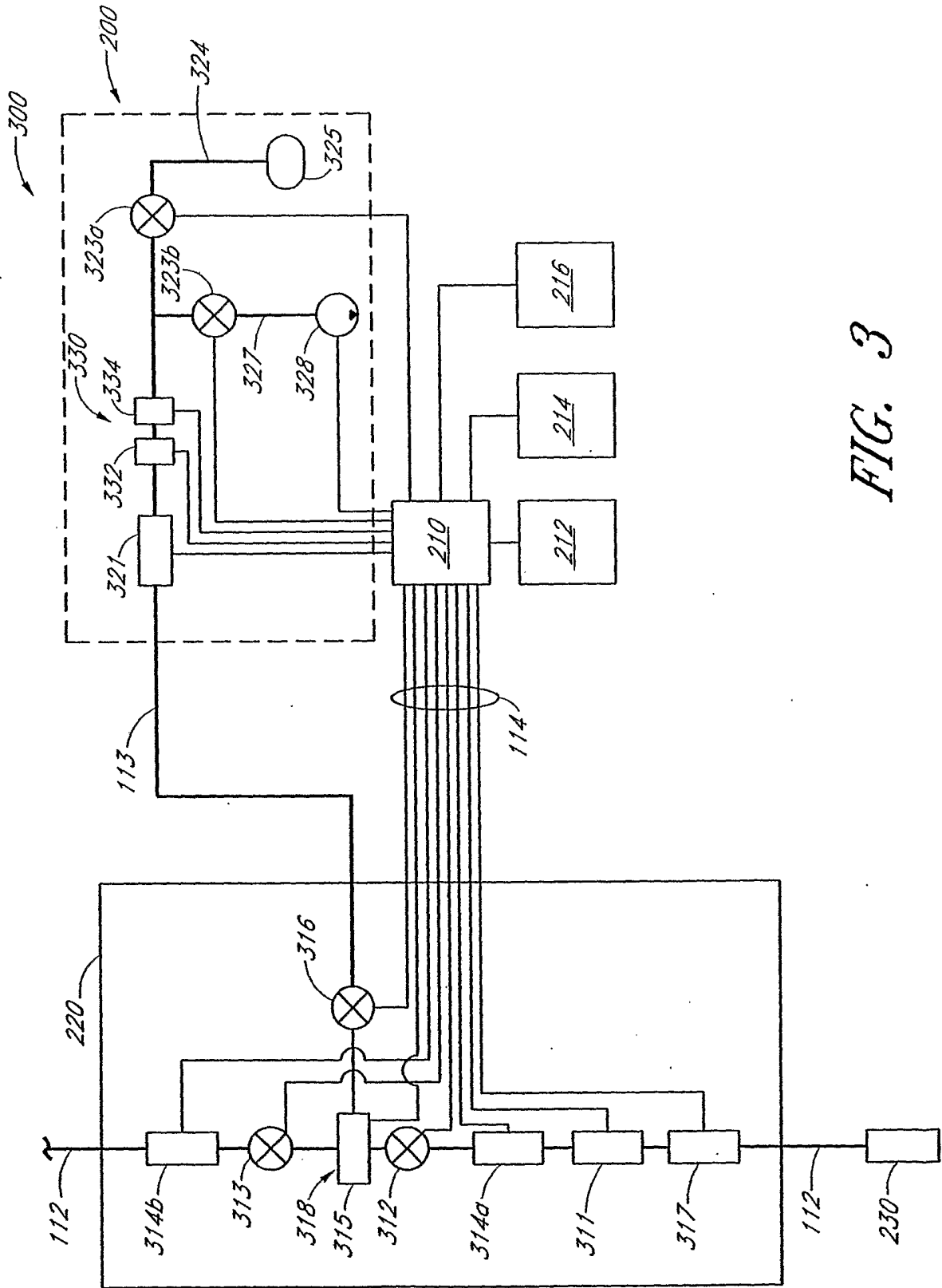

FIG. 3

400

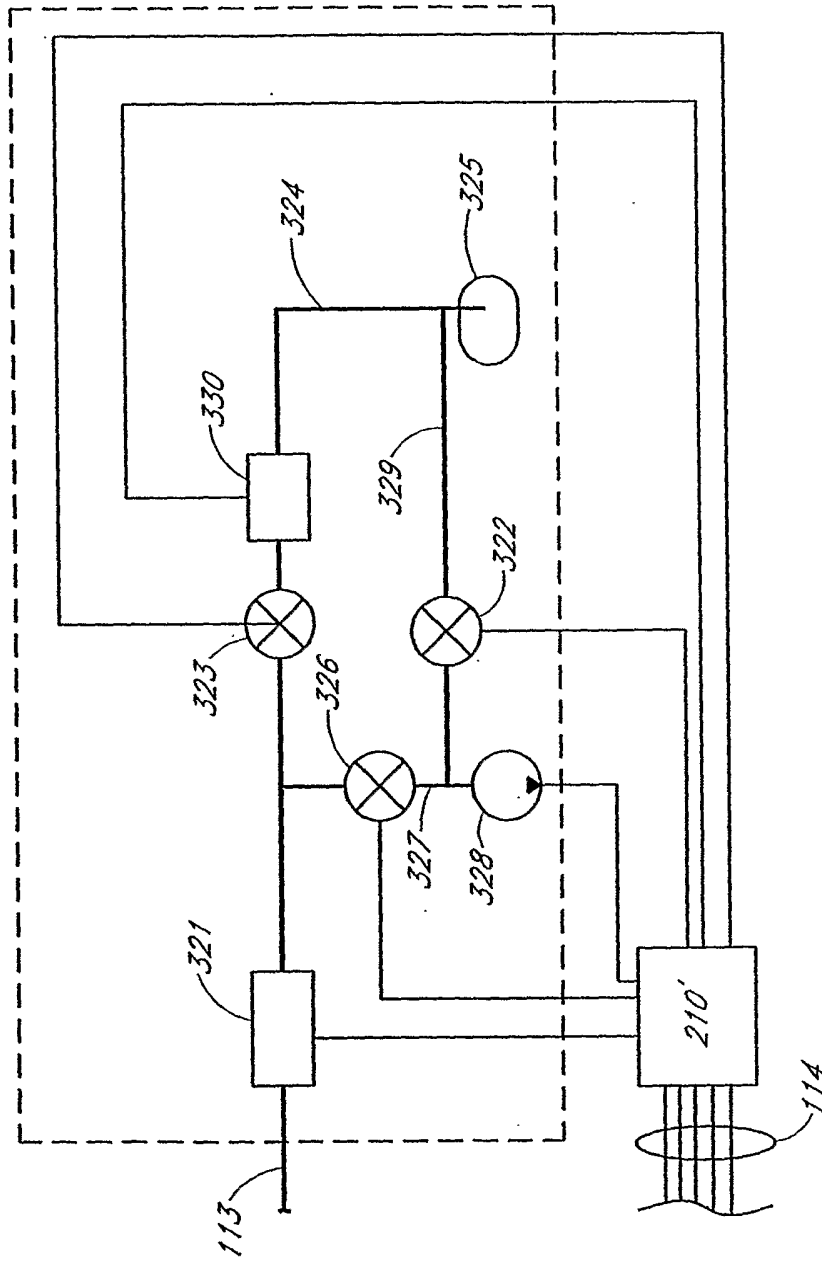

FIG. 4

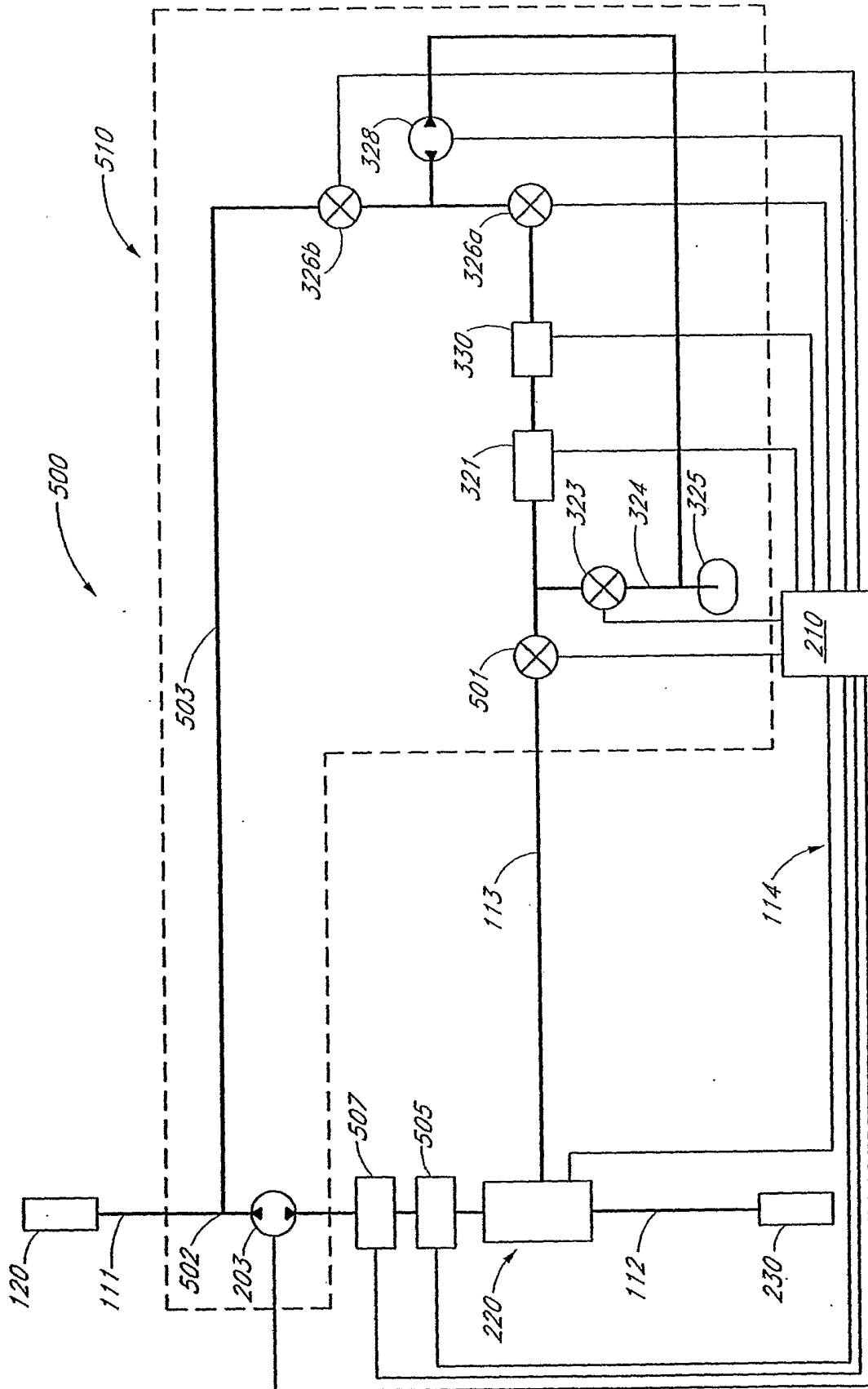

FIG. 5

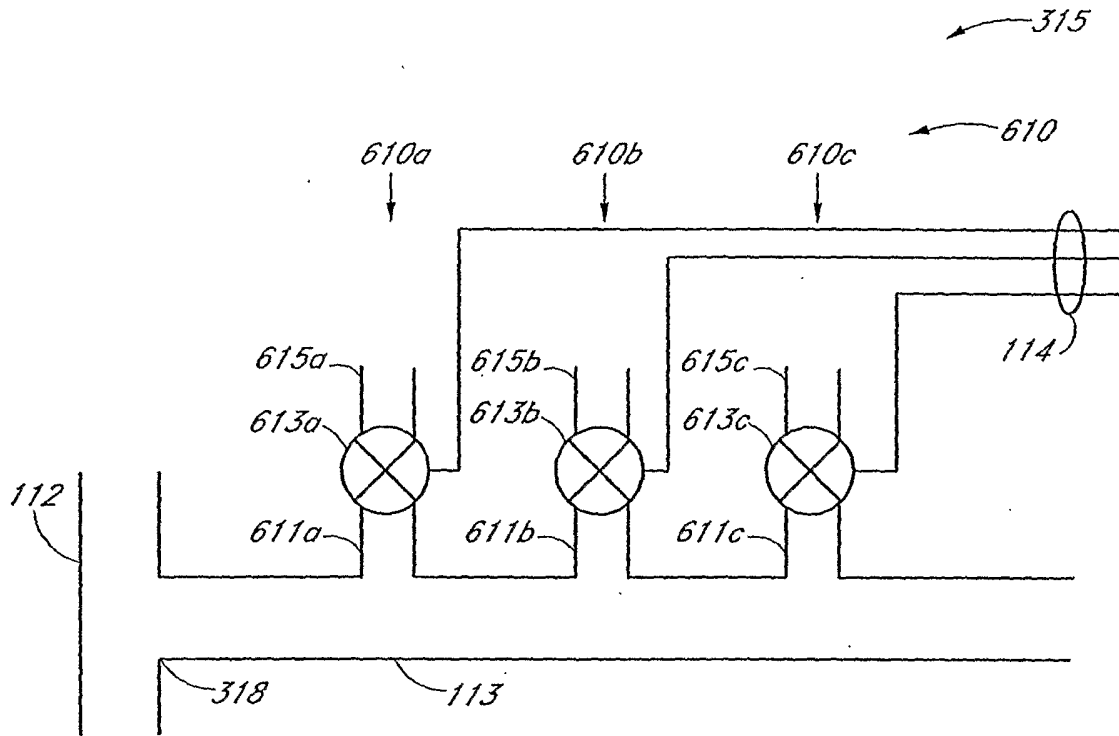

FIG. 6A

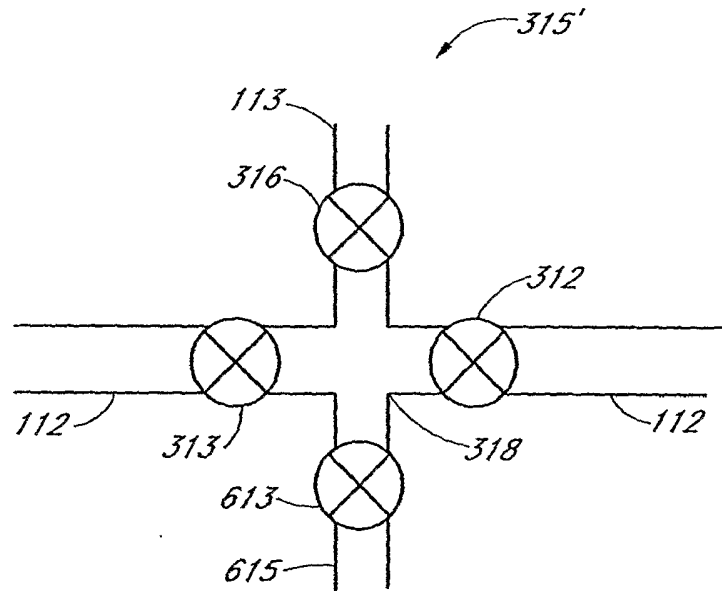

FIG. 6B

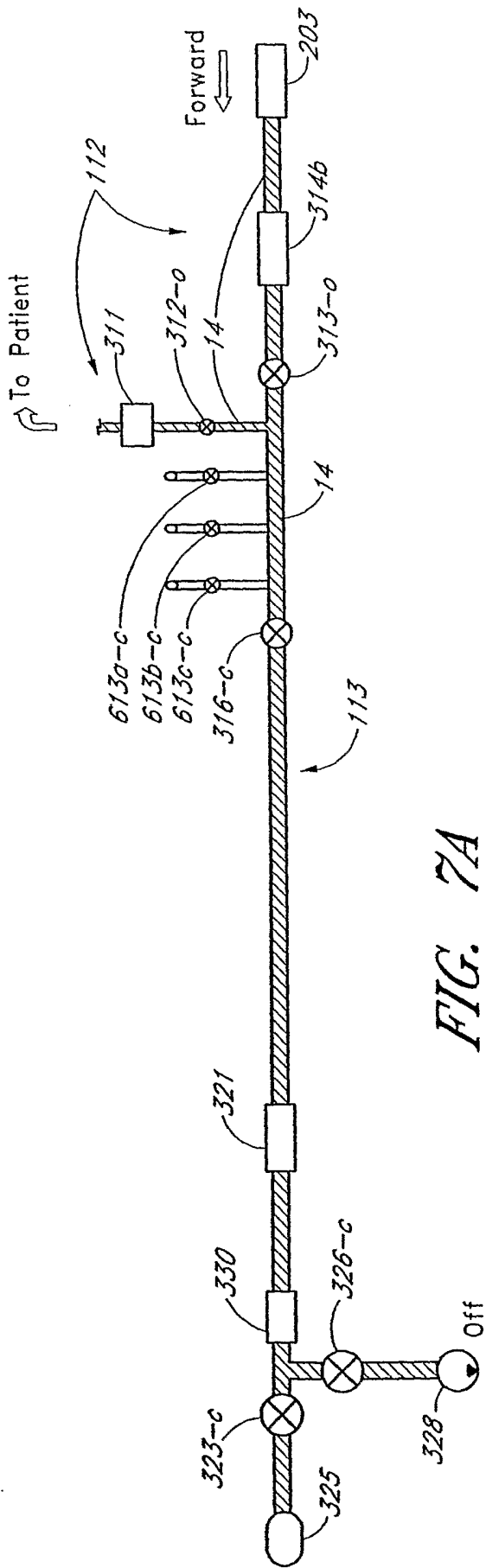

FIG. 7A

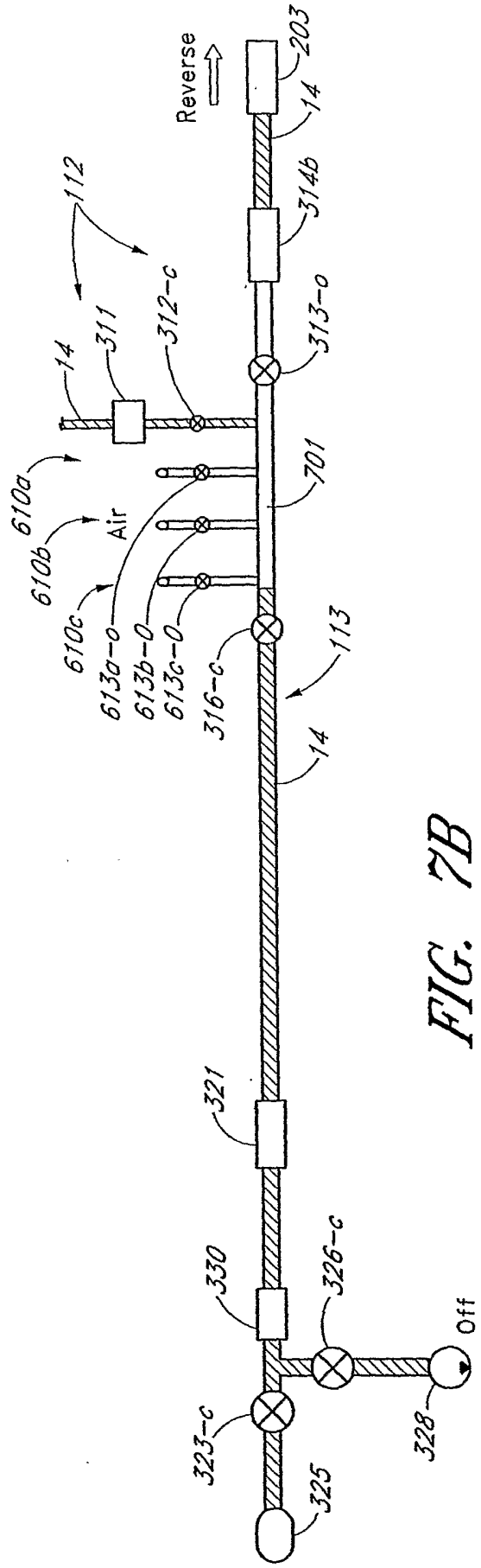

FIG. 7B

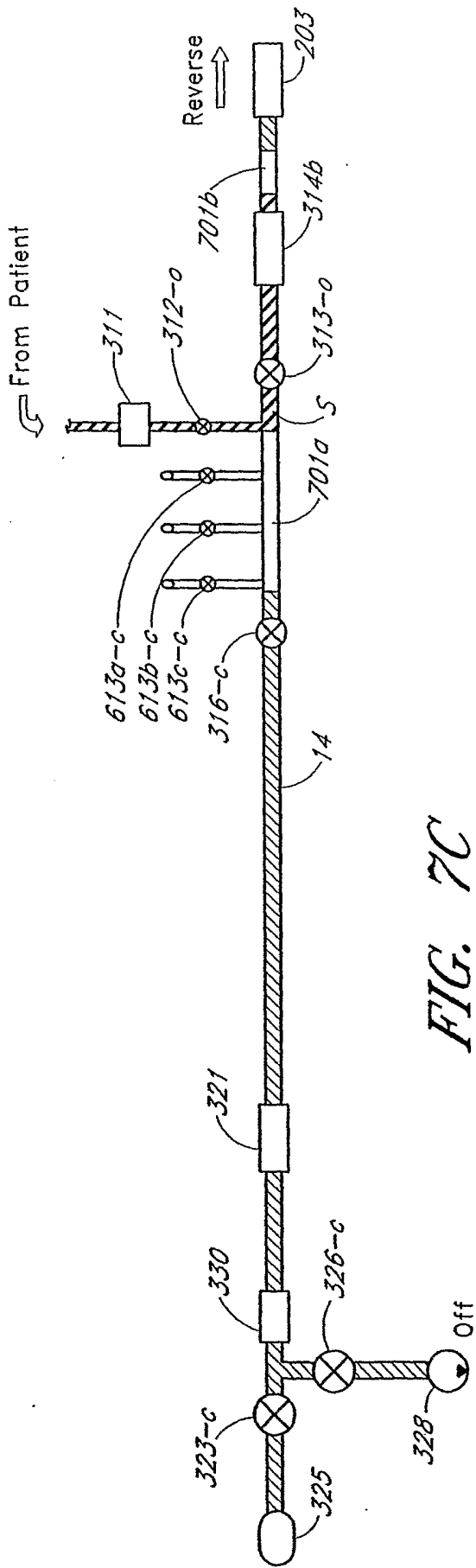

FIG. 7C

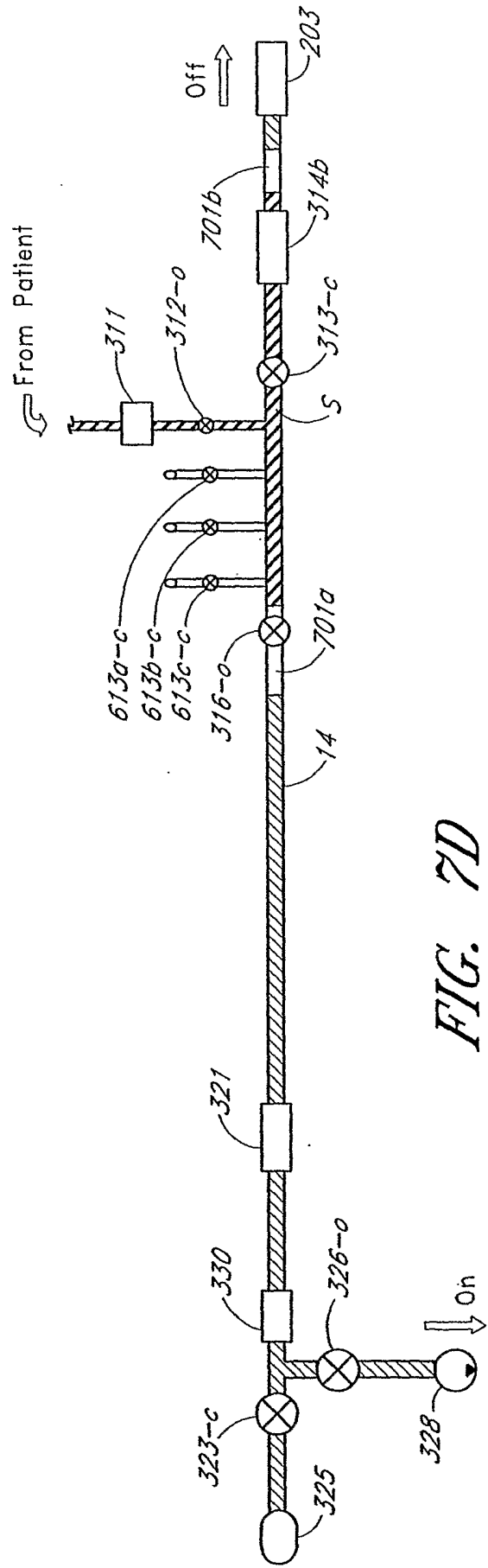

FIG. 7D

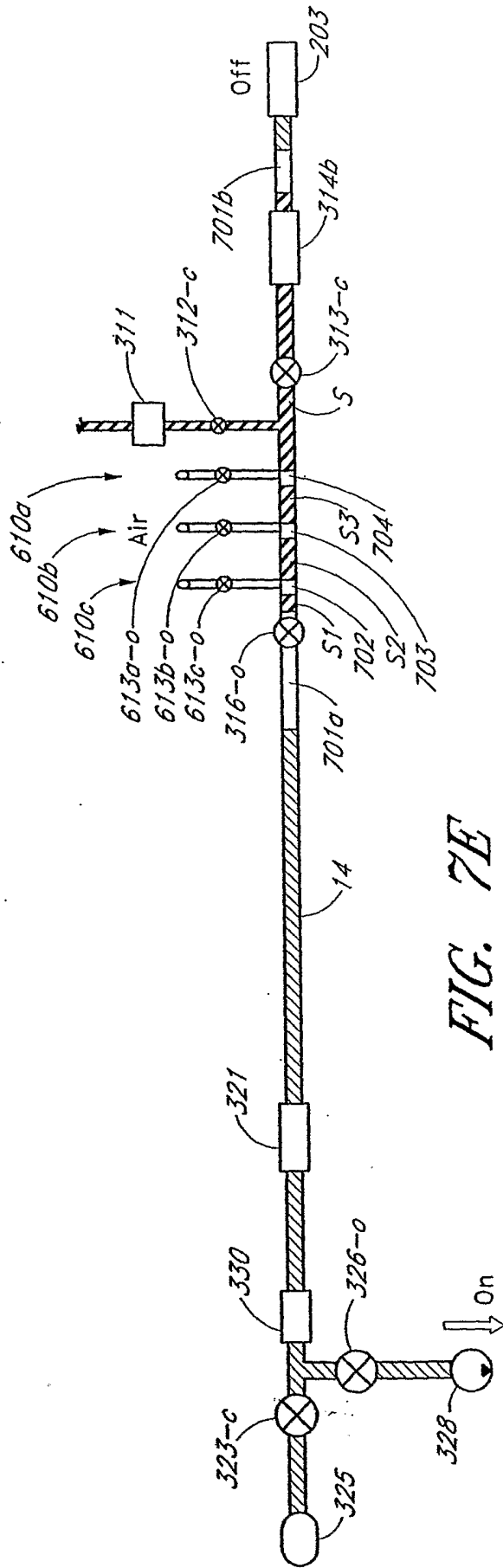

FIG. 7E

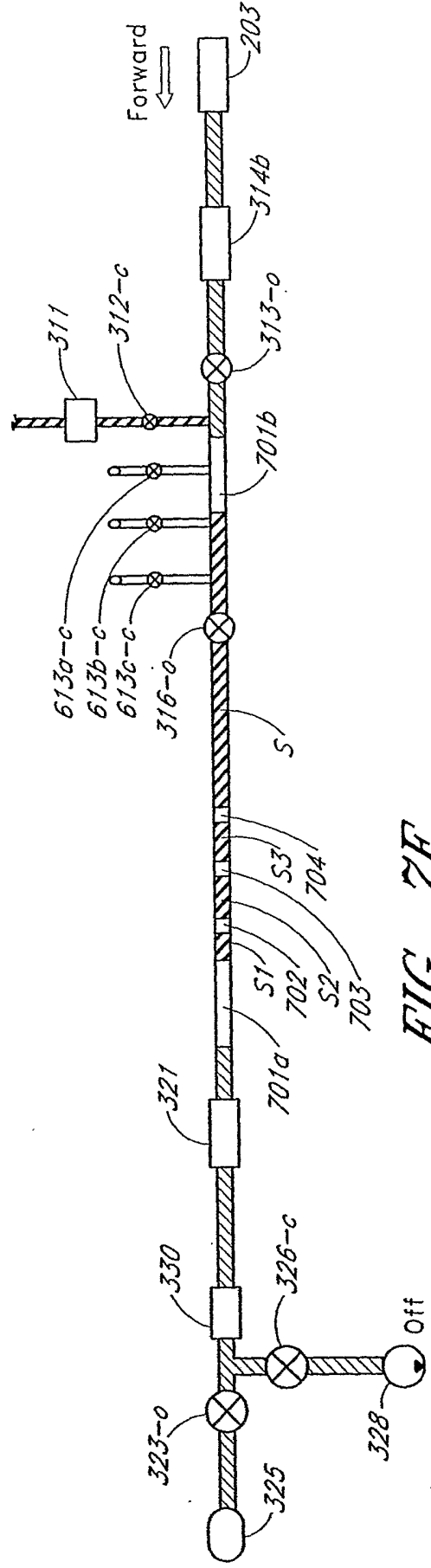

FIG. 7F

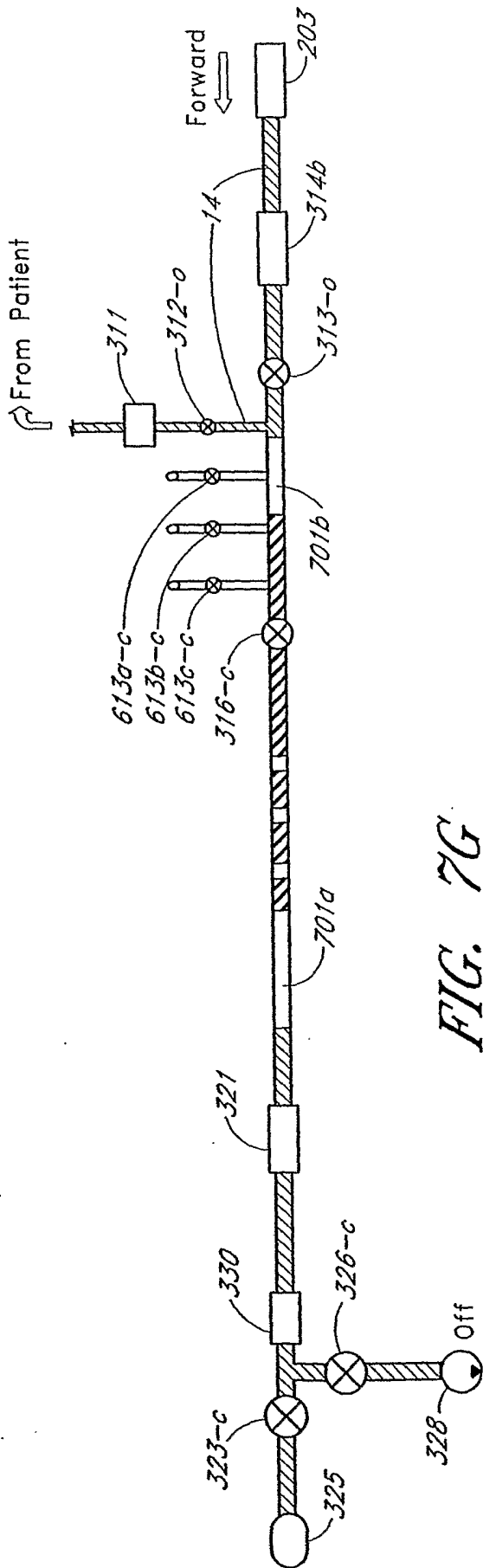

FIG. 7G

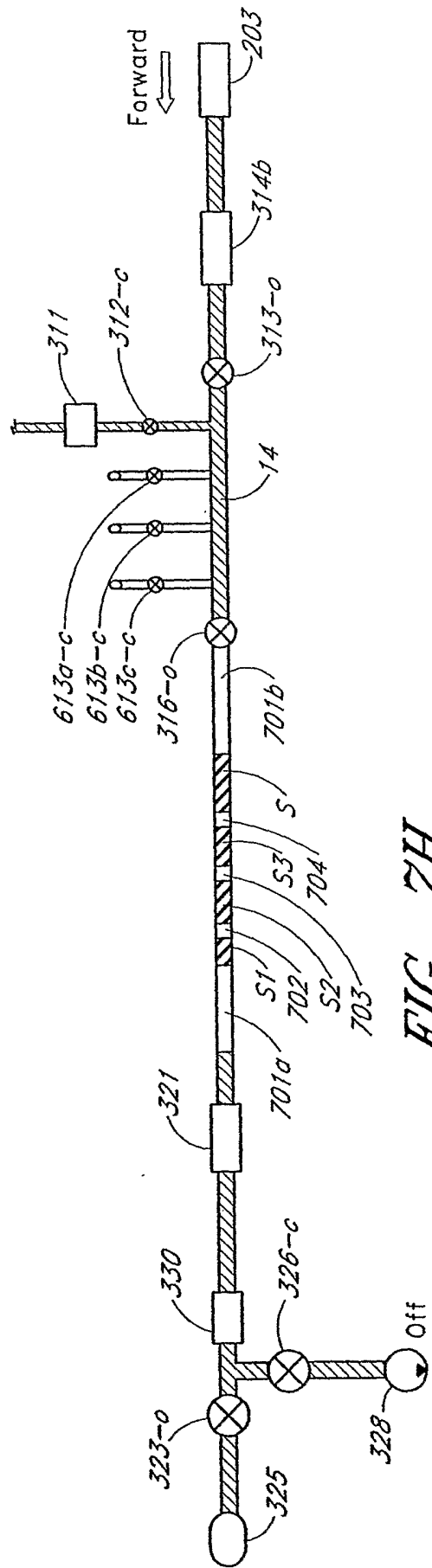

FIG. 7H

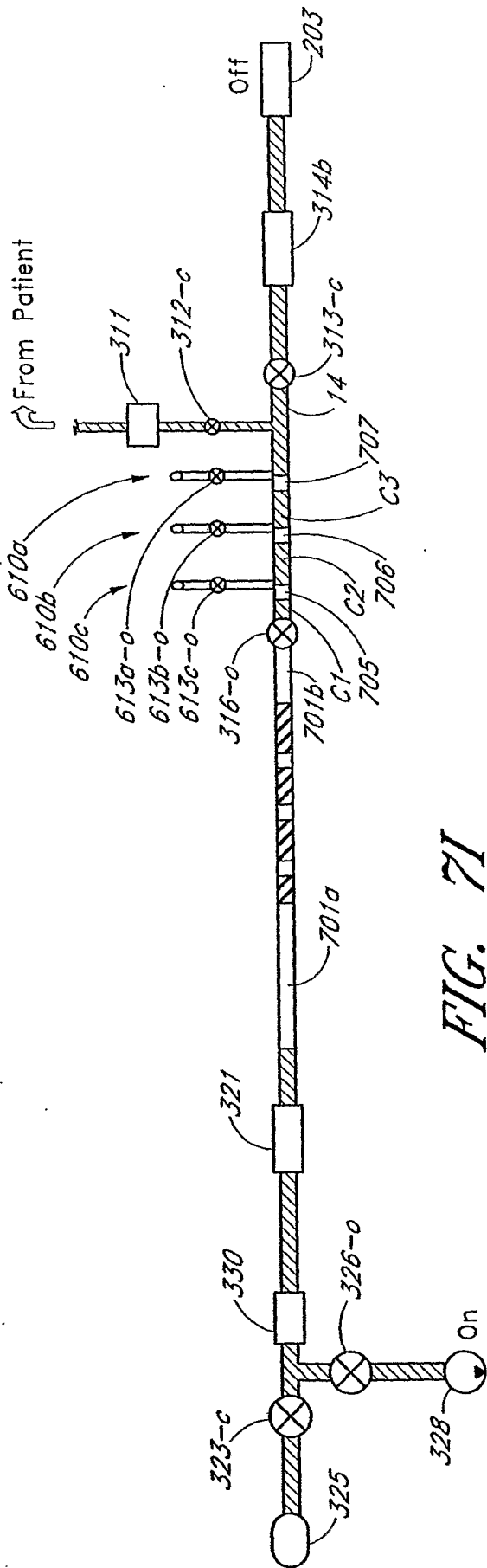

FIG. 7I

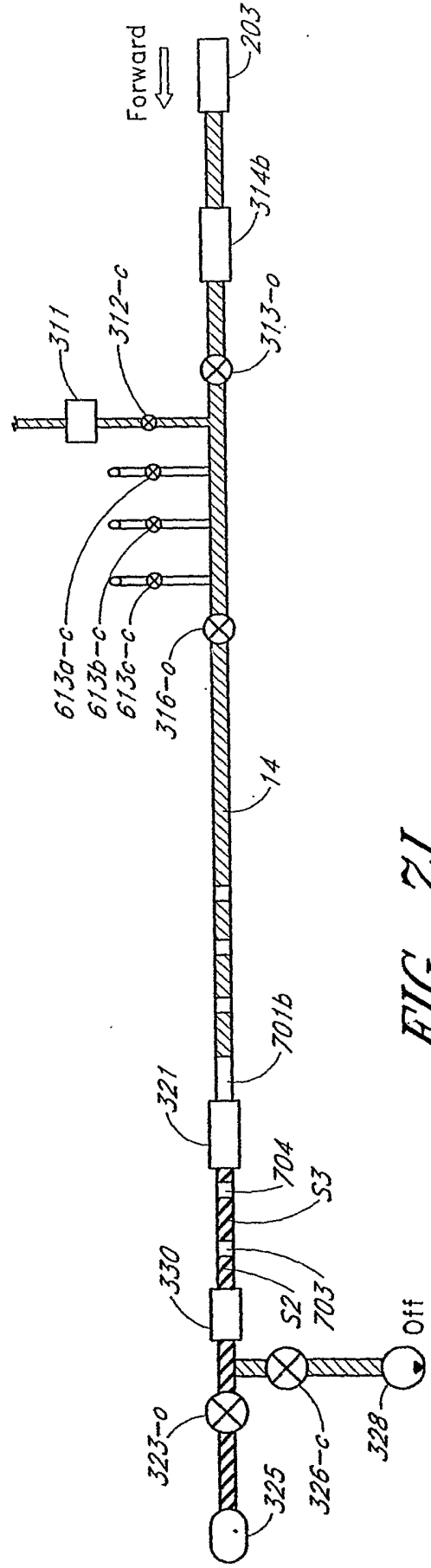
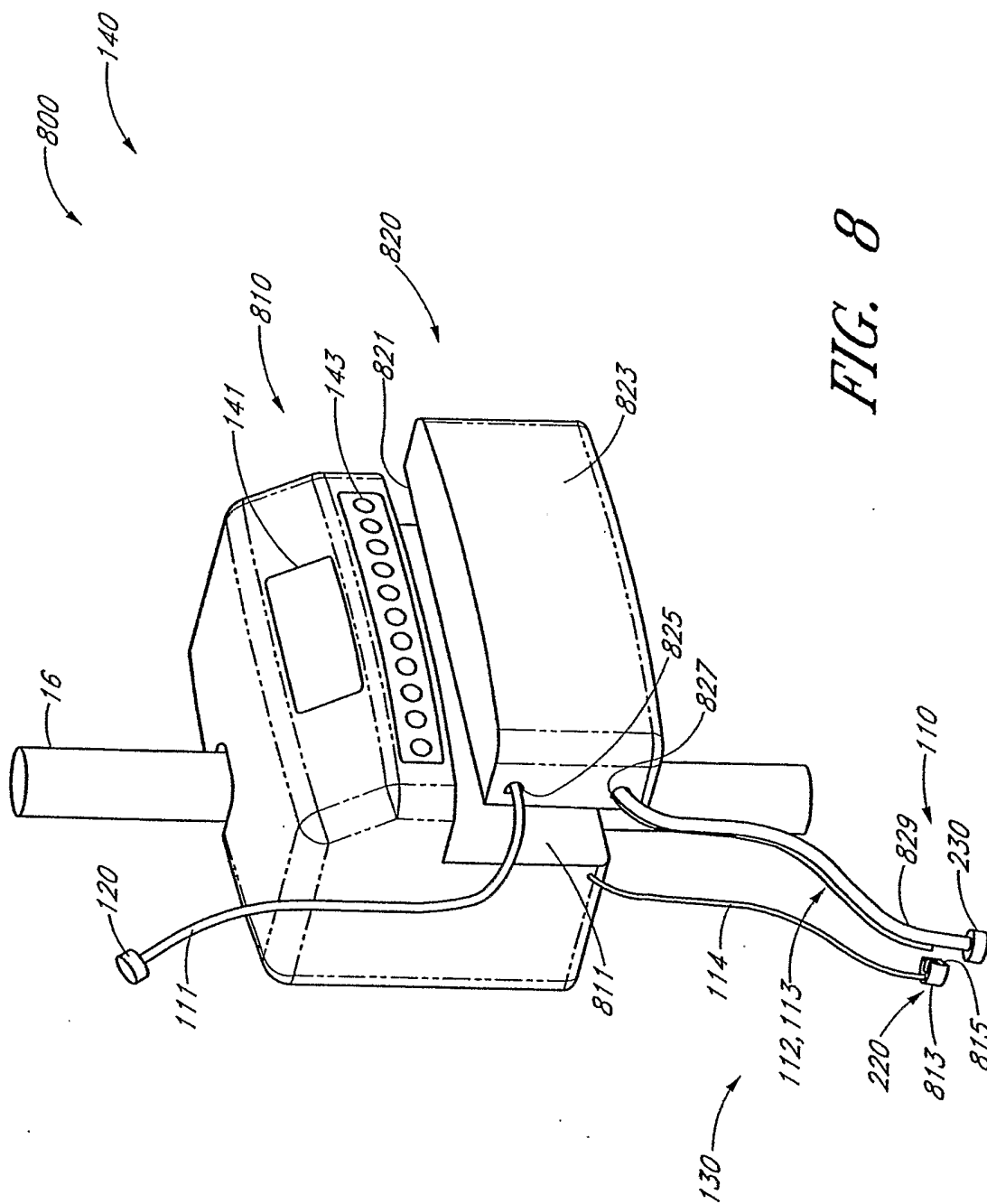

FIG. 7J



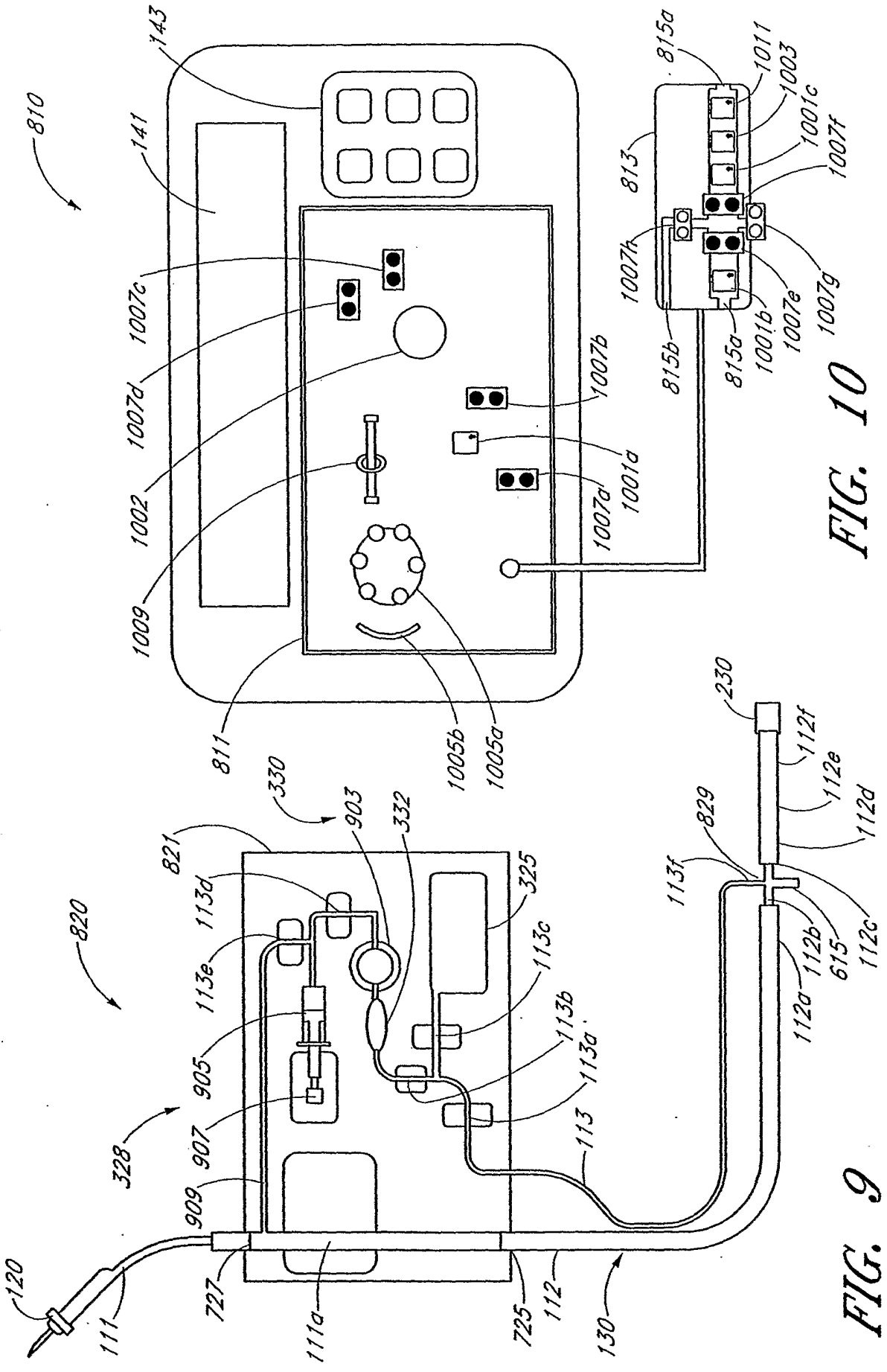

FIG. 10

FIG. 9

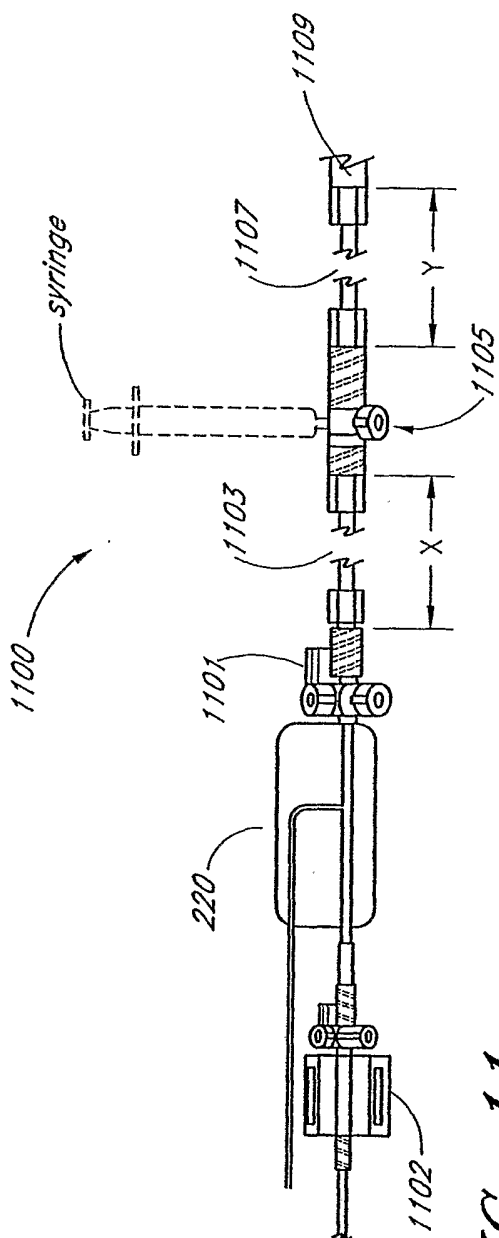

FIG. 11

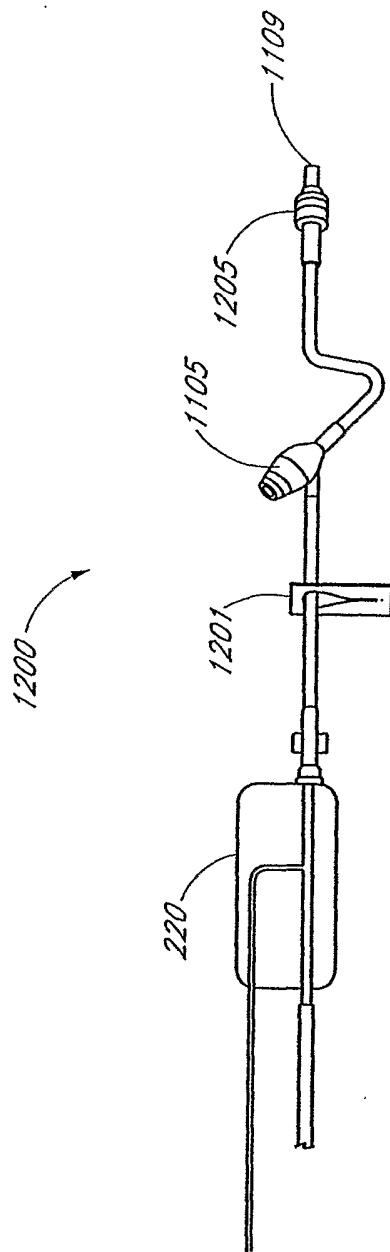

FIG. 12

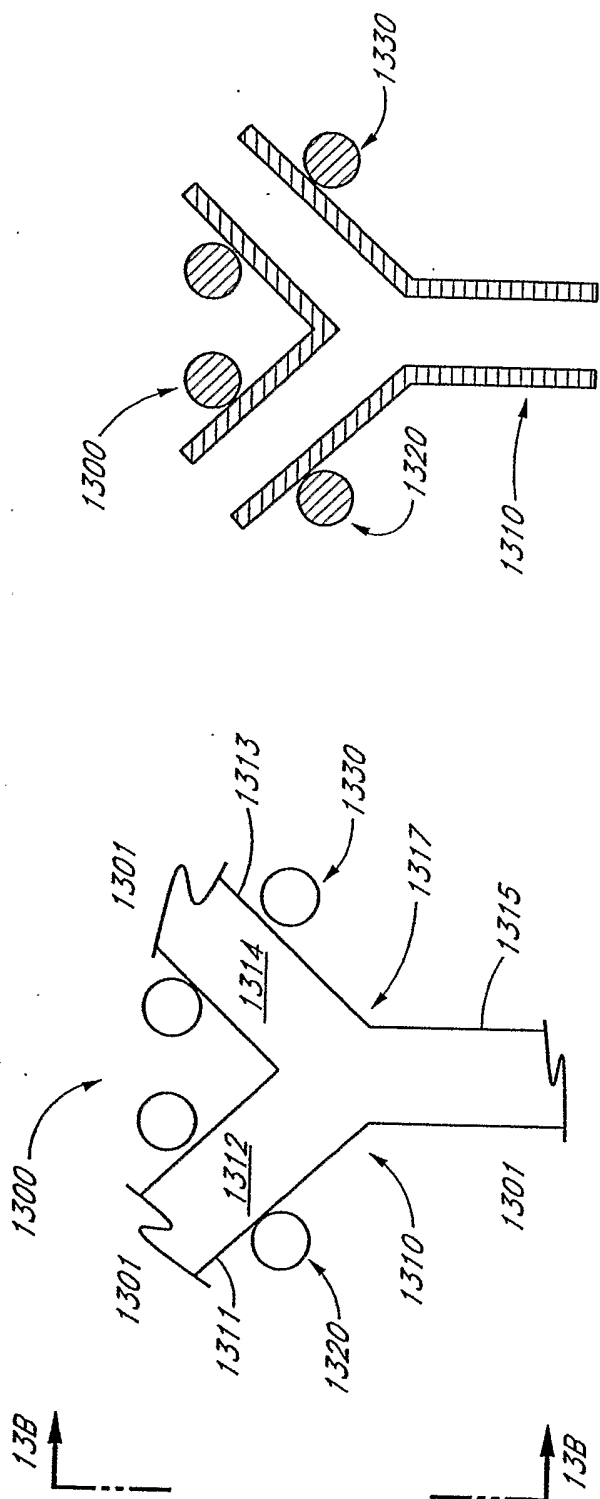

FIG. 13A

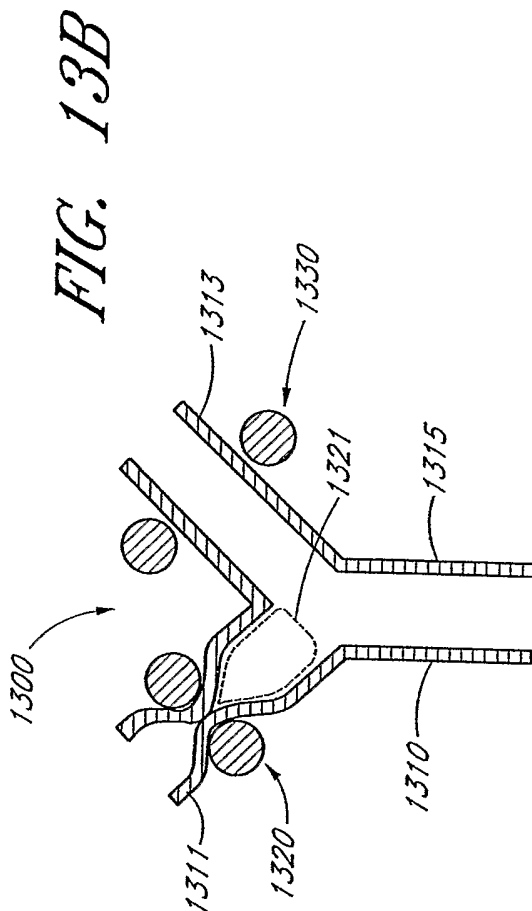

FIG. 13B

FIG. 13C

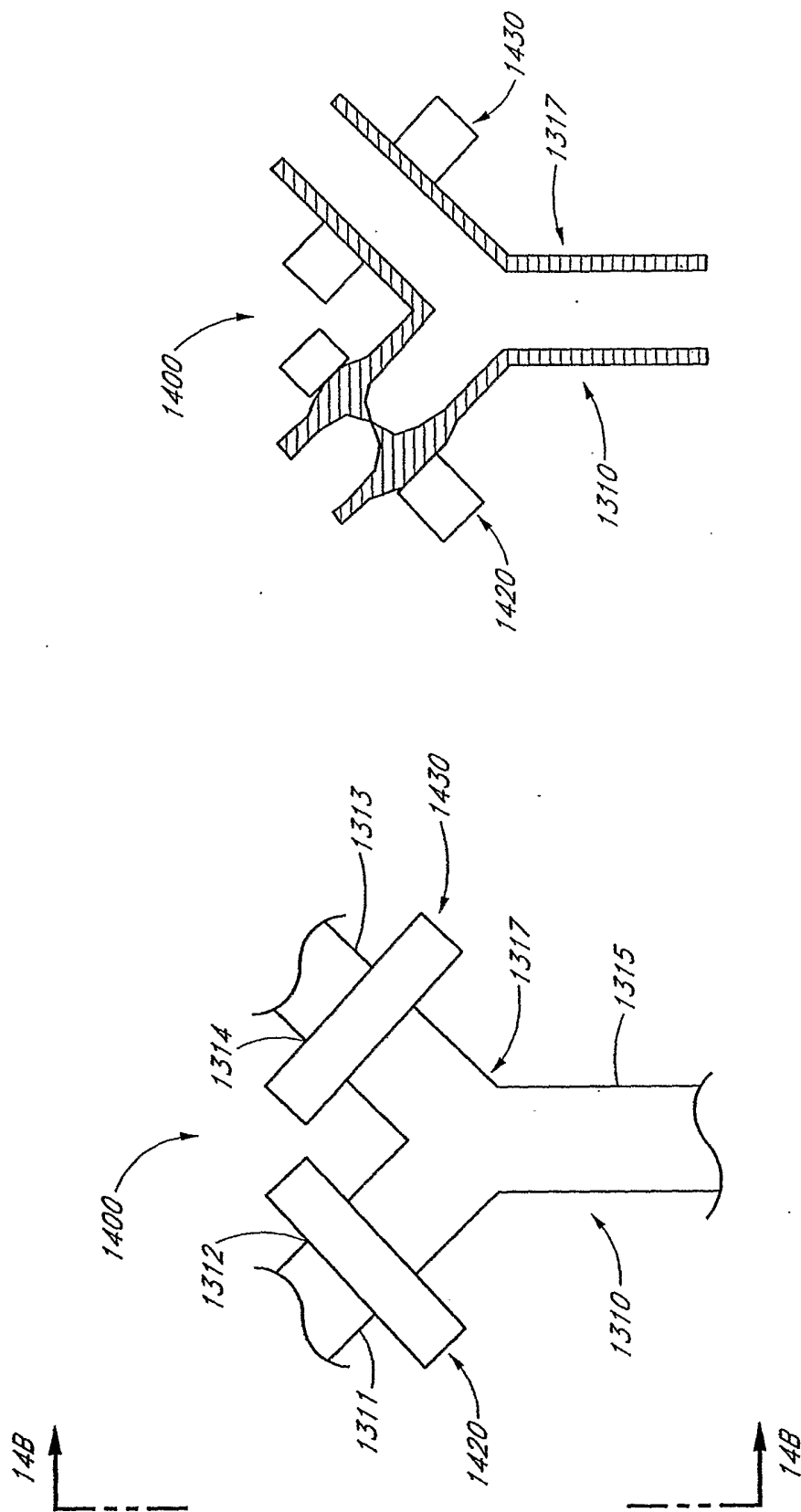

FIG. 14B

FIG. 14A

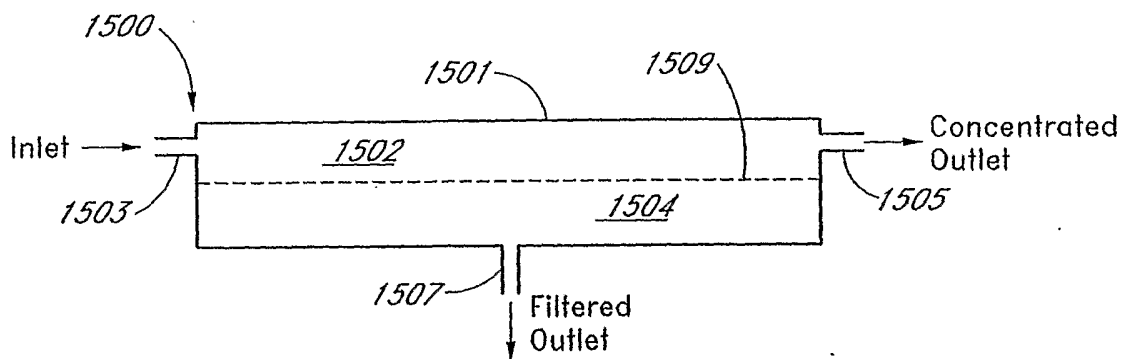

FIG. 15

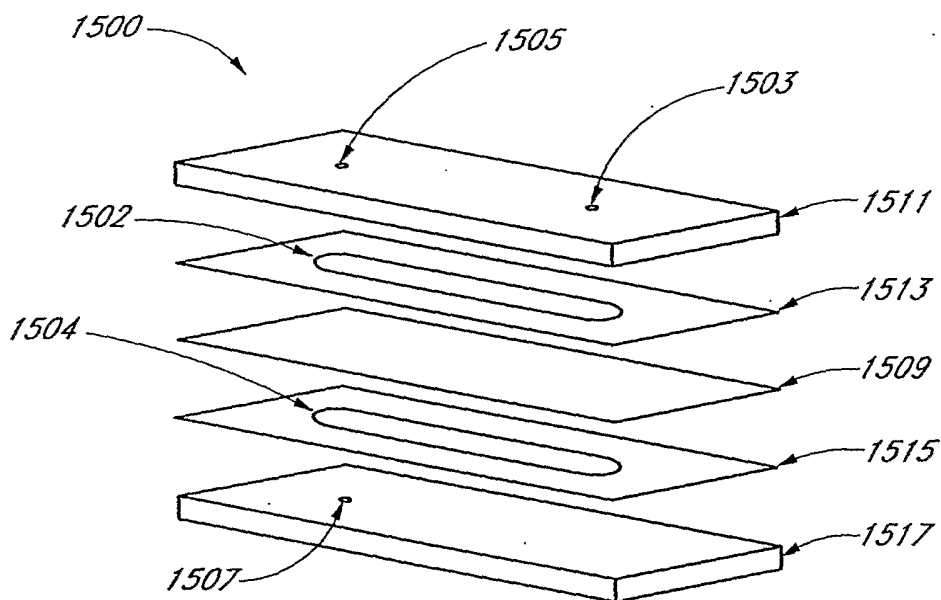

FIG. 16

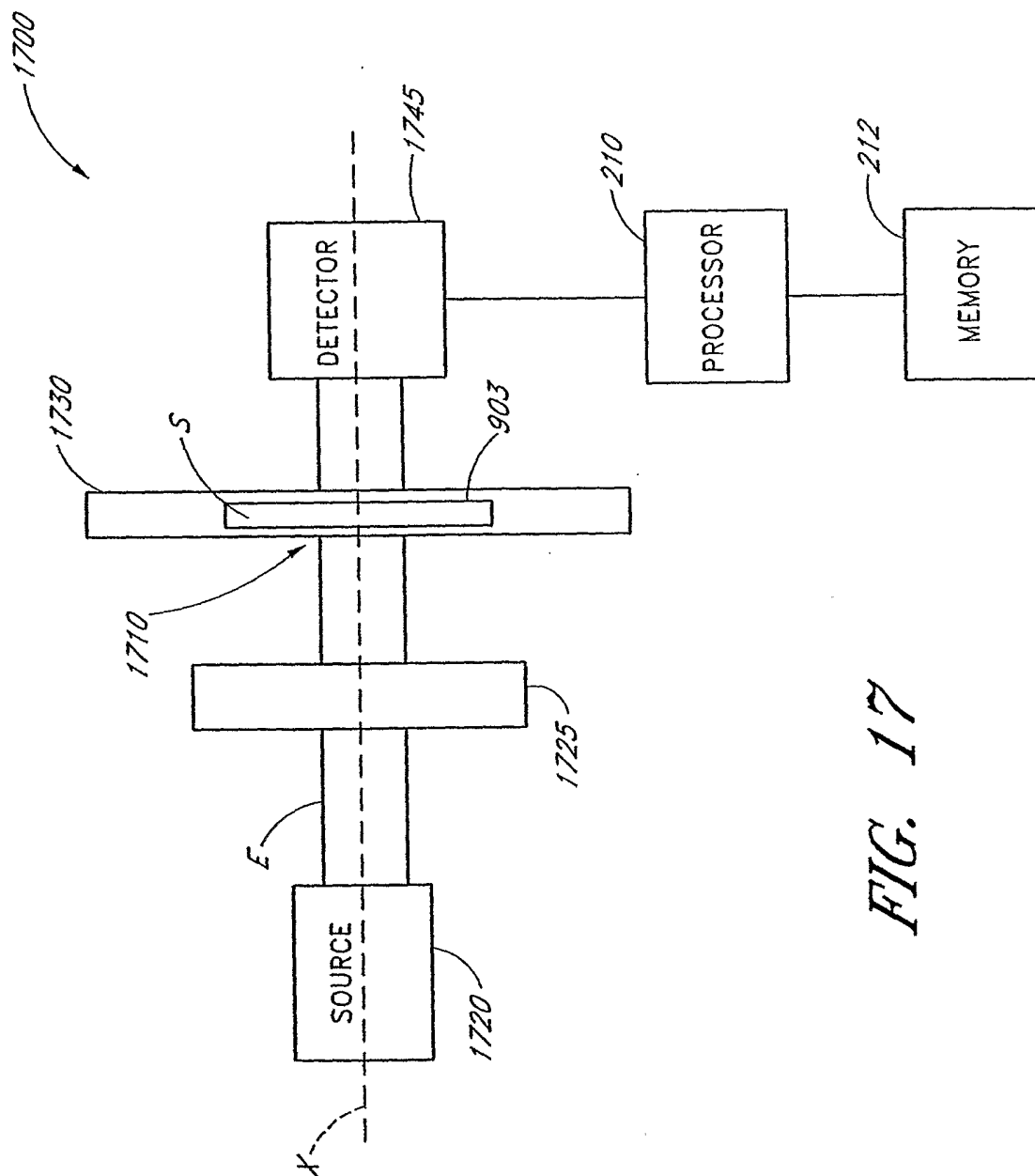

FIG. 17

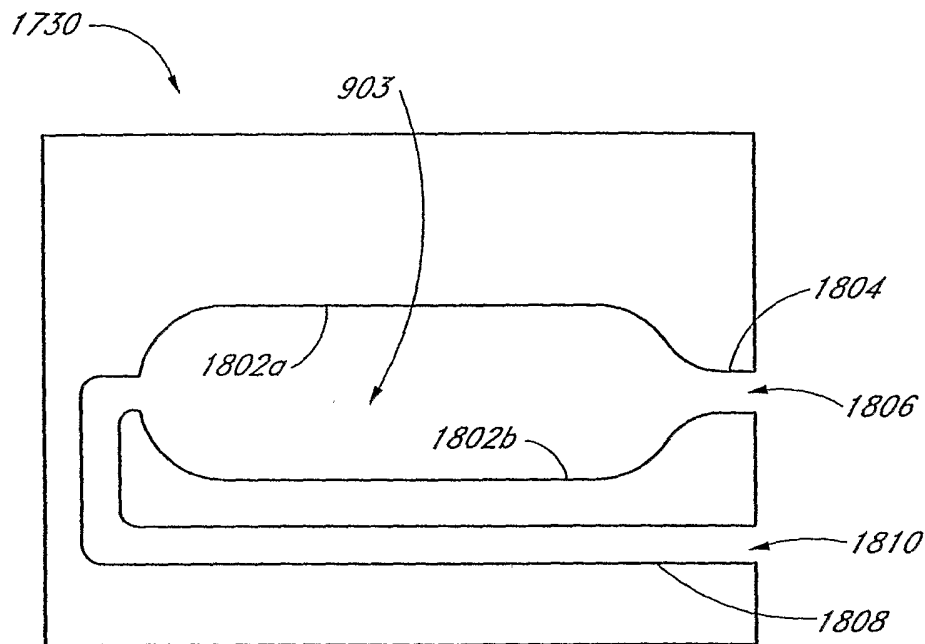

FIG. 18

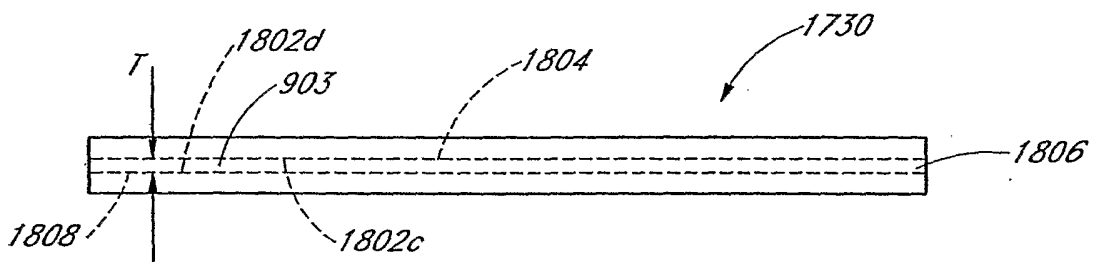

FIG. 19

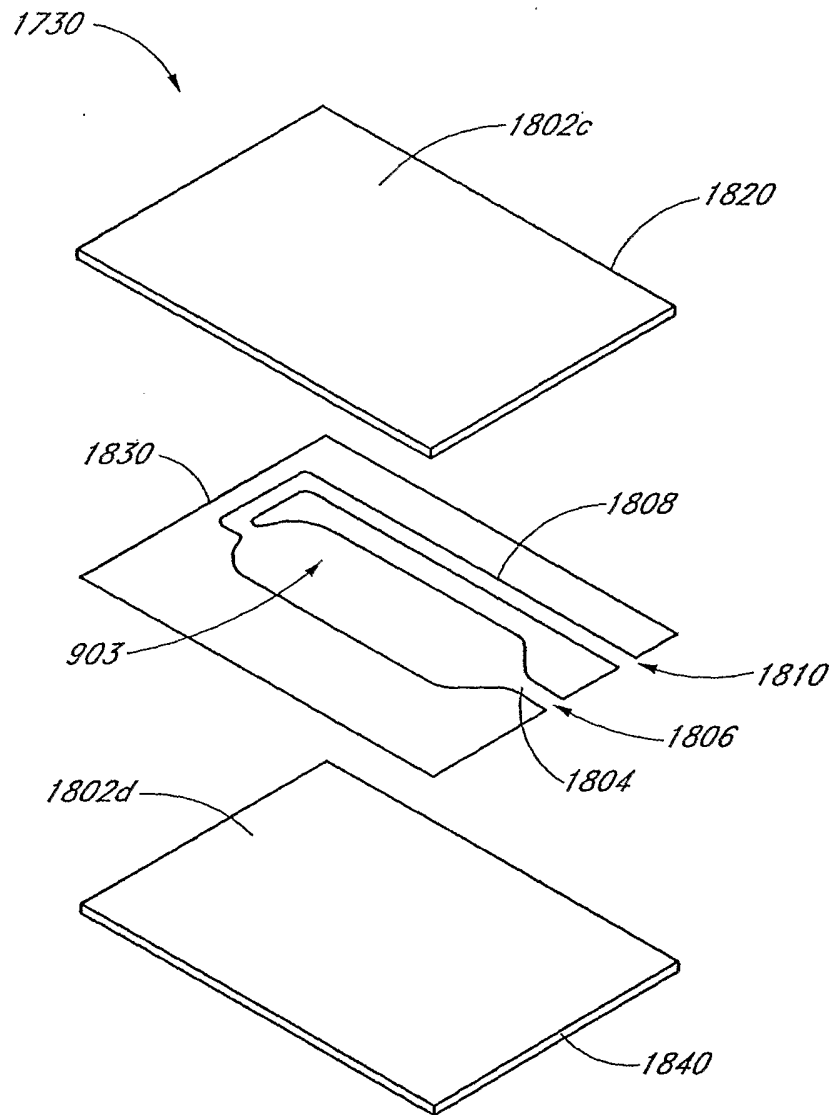

FIG. 20

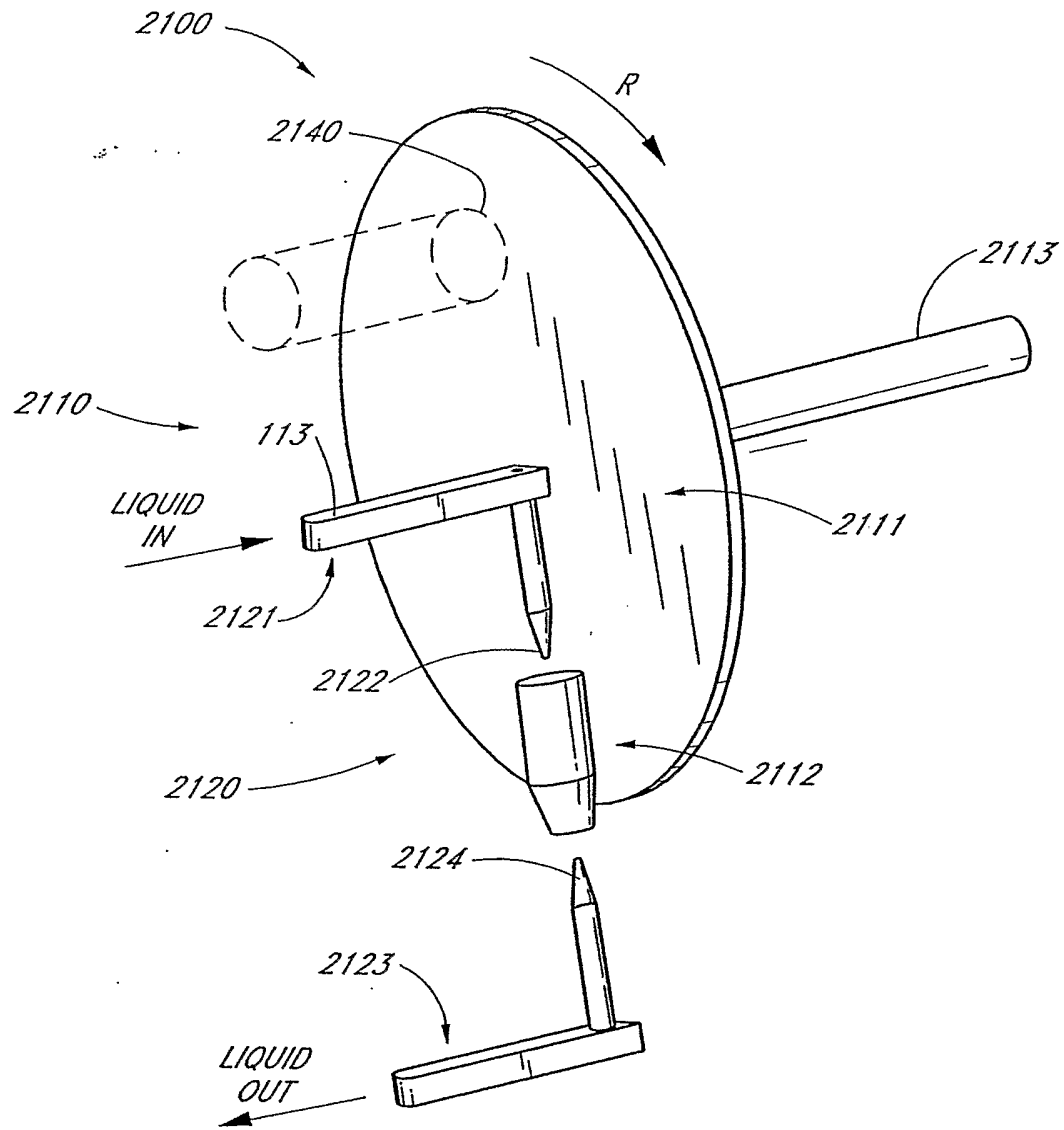

FIG. 21

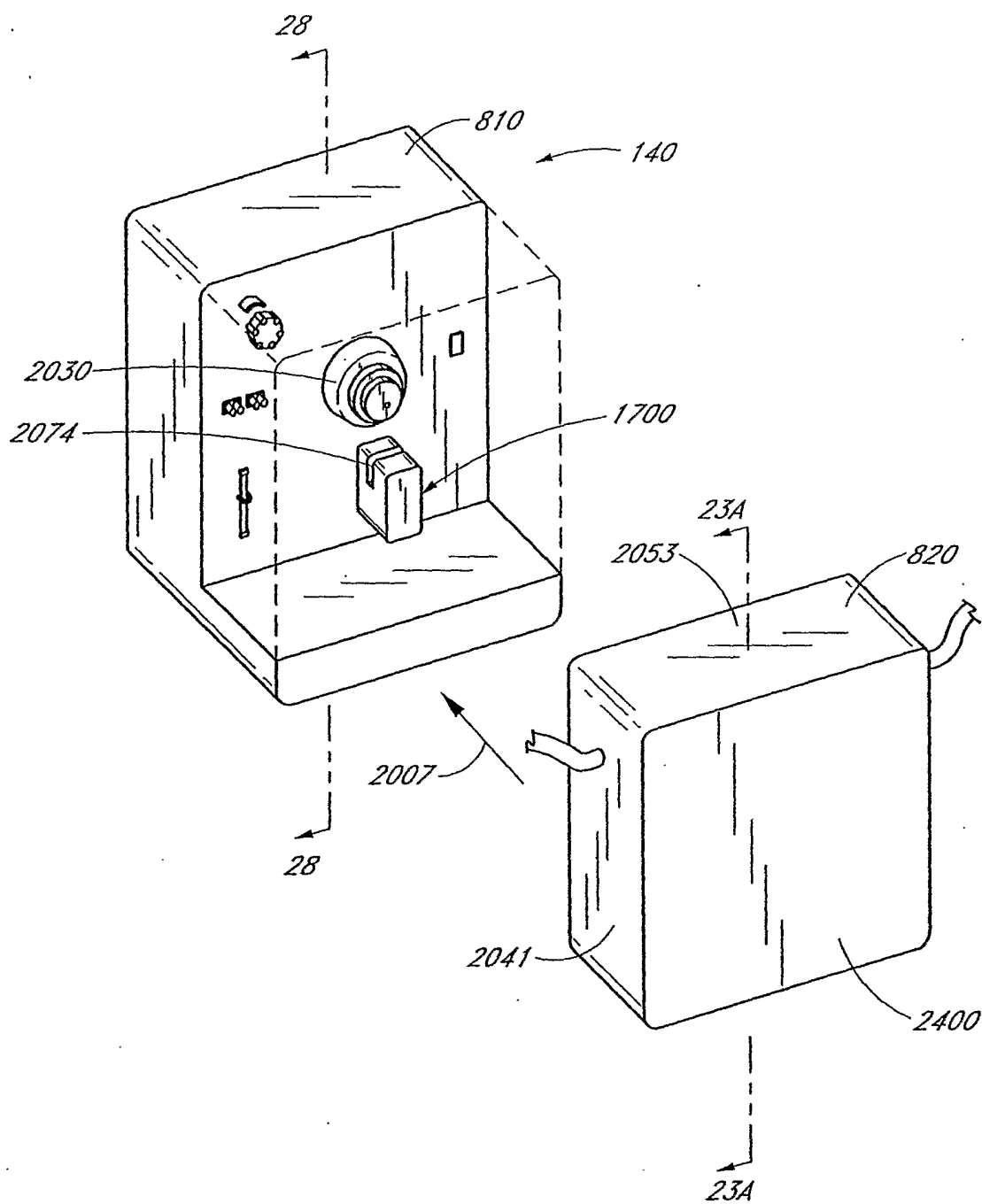

FIG. 22A

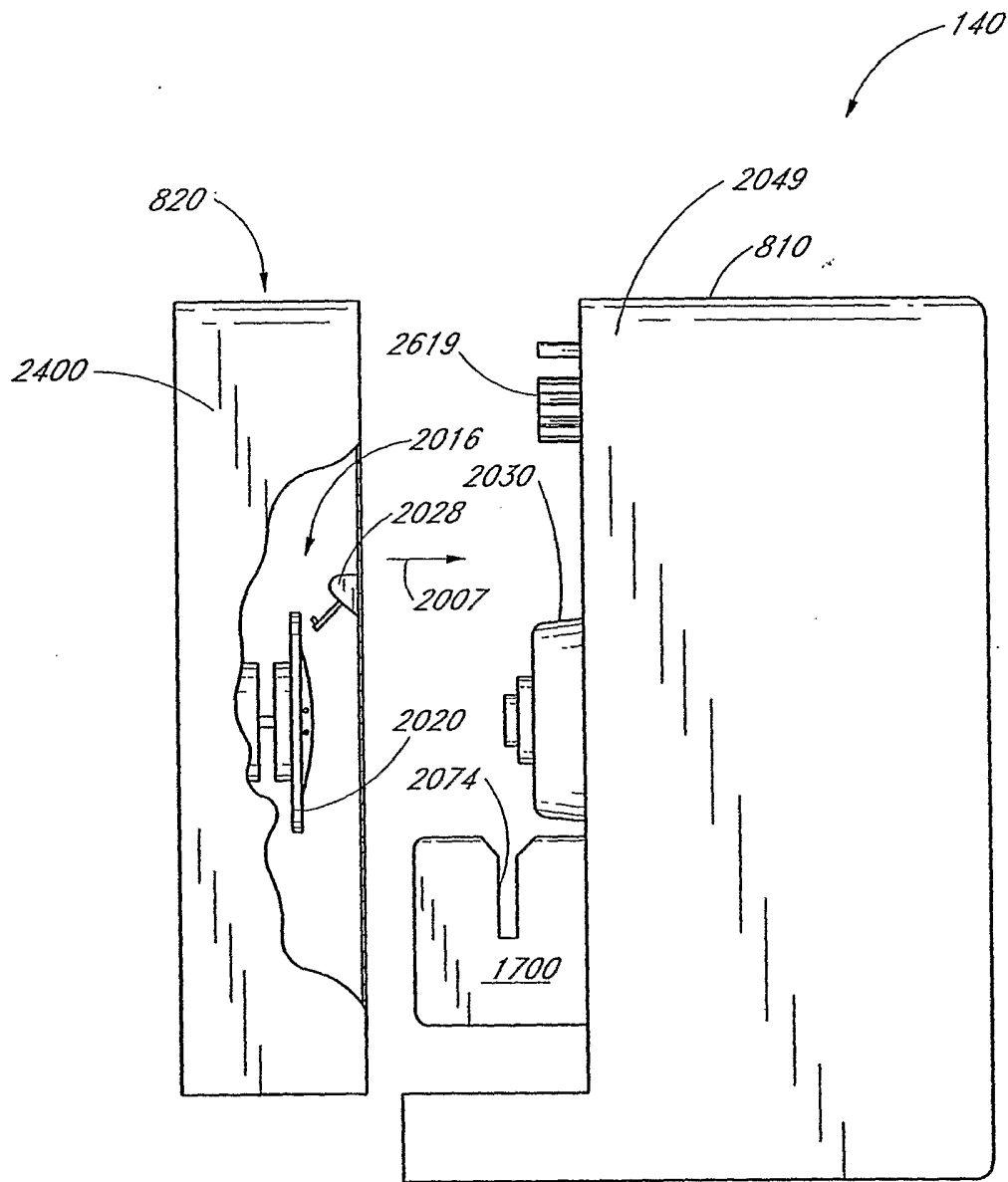

FIG. 22B

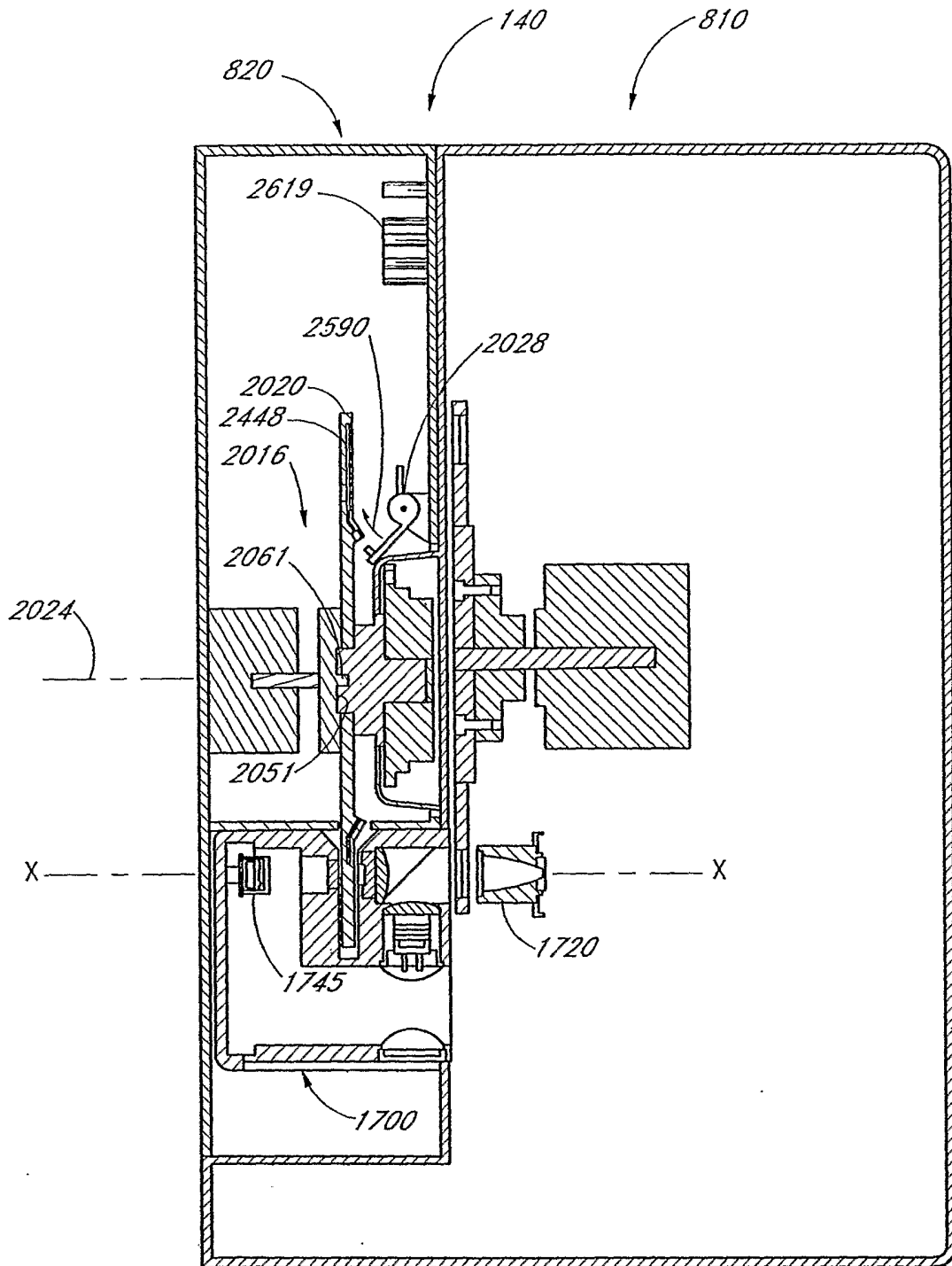

FIG. 22C

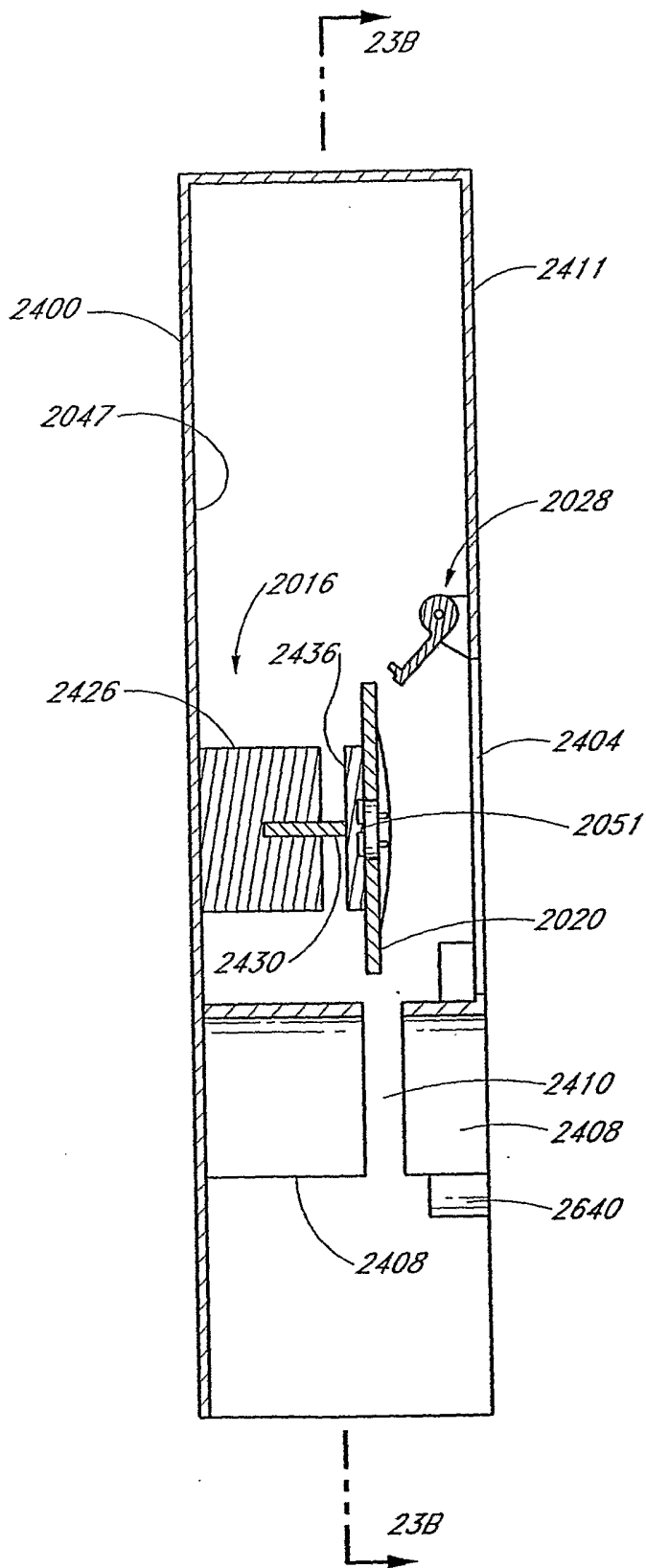

FIG. 23A

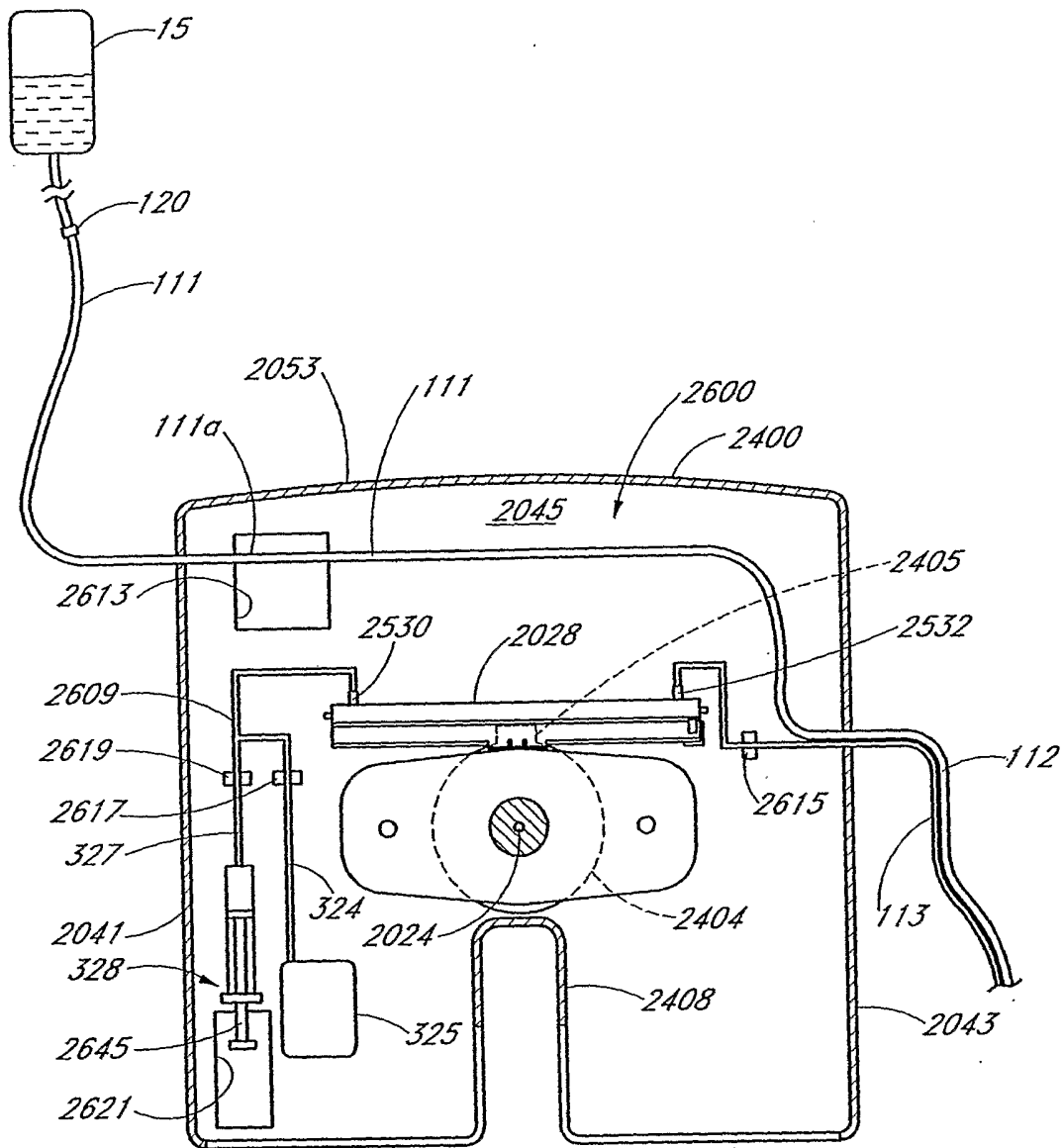

FIG. 23B

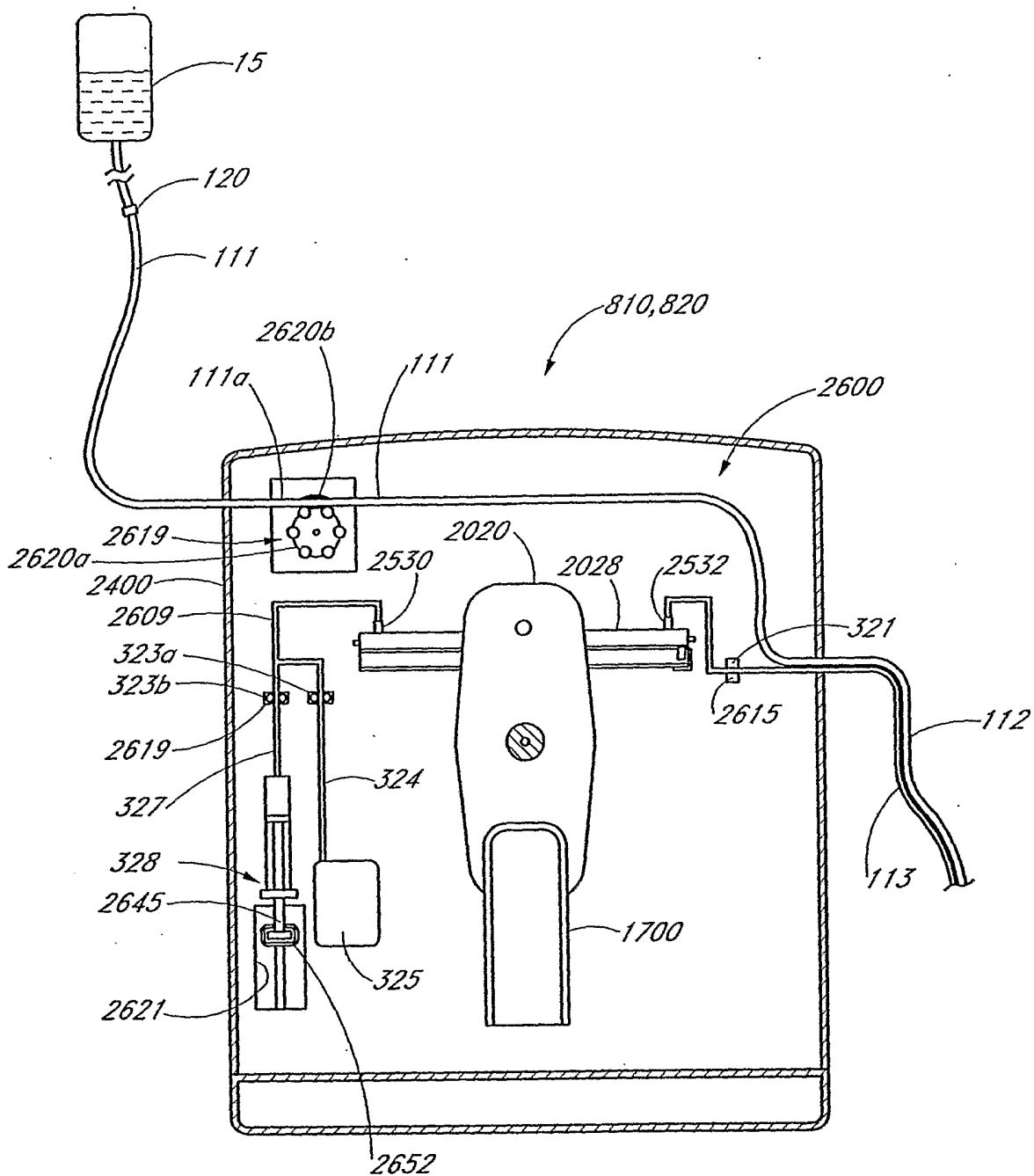

FIG. 23C

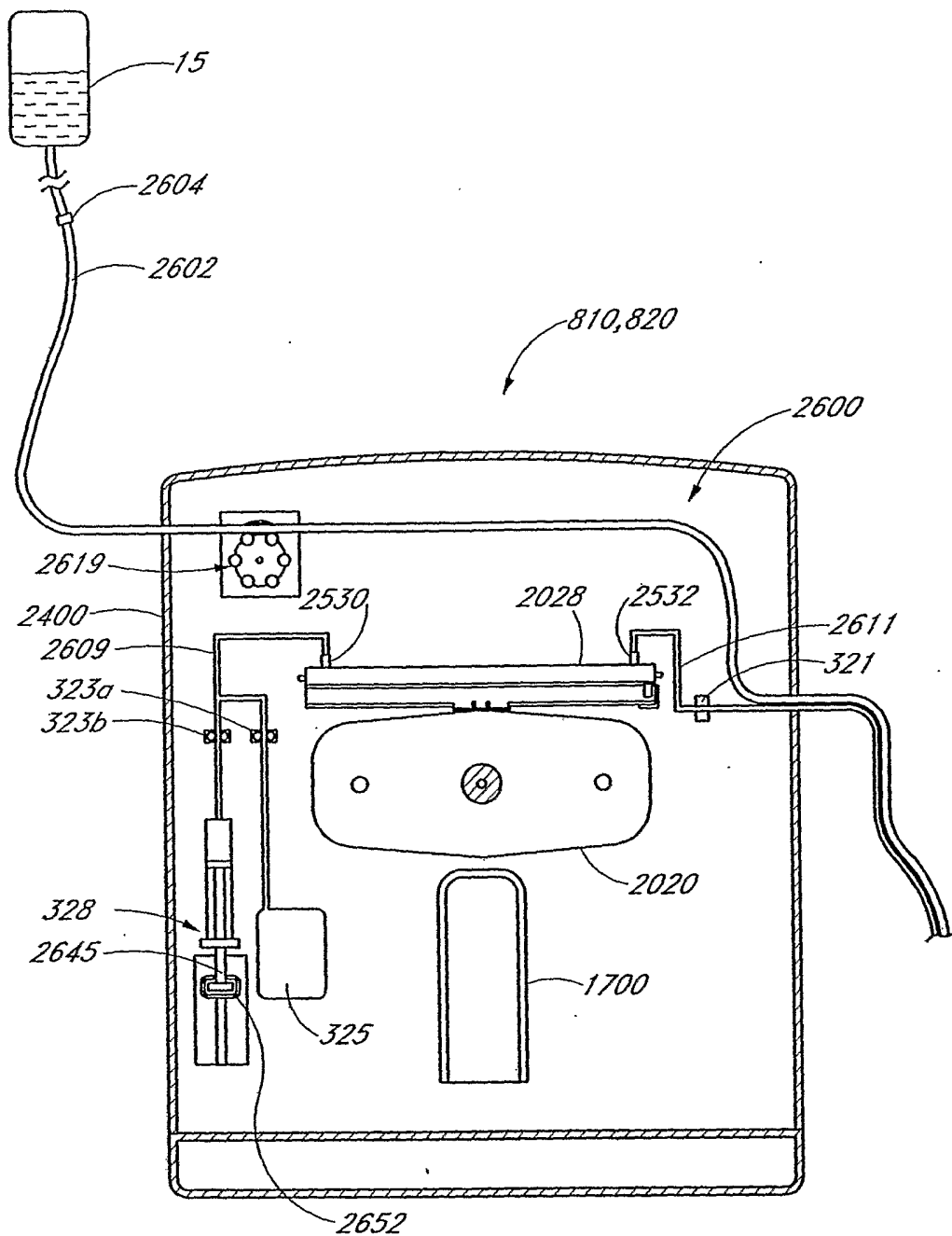

FIG. 23D

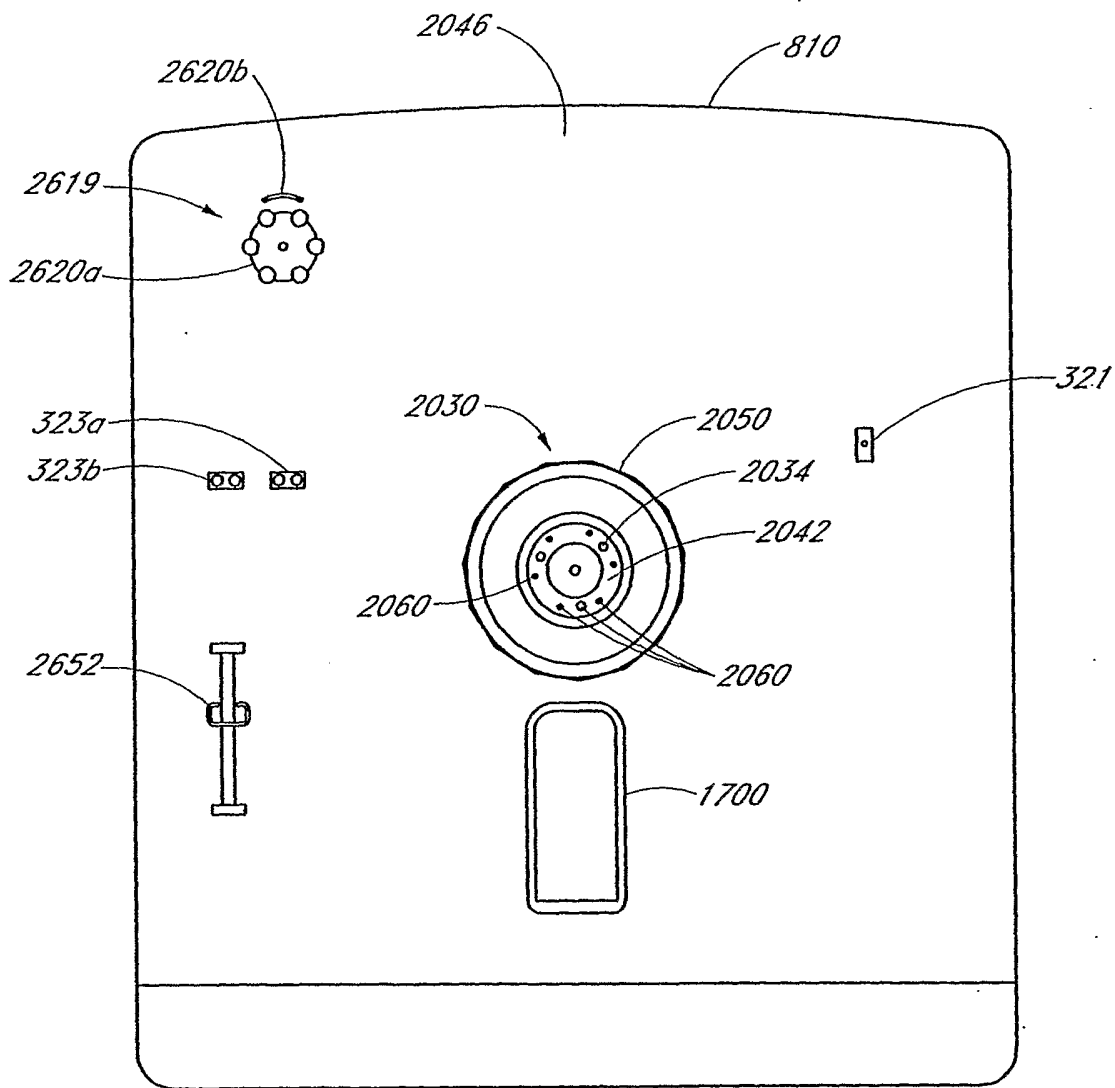

FIG. 23E

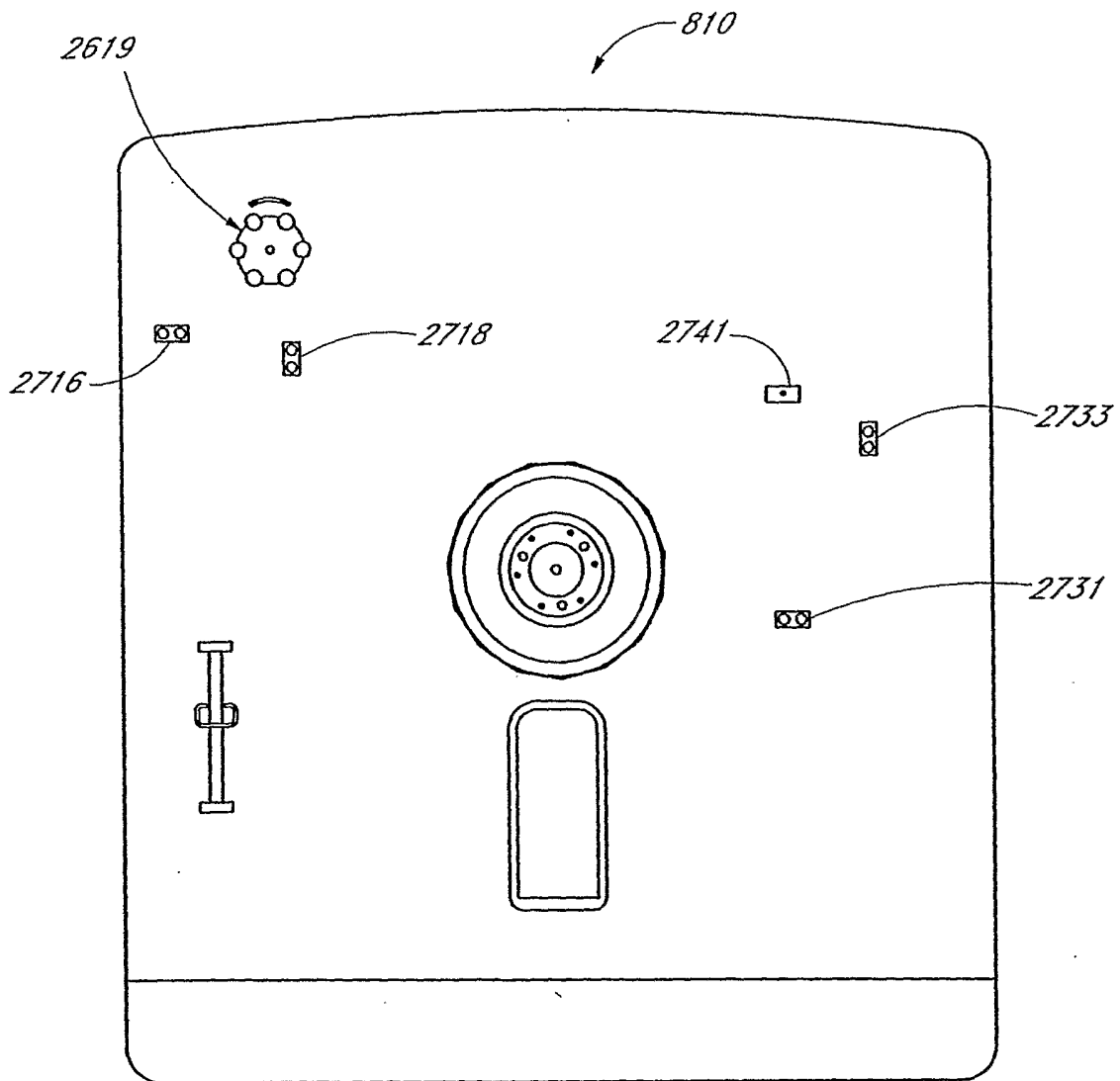

FIG. 24B

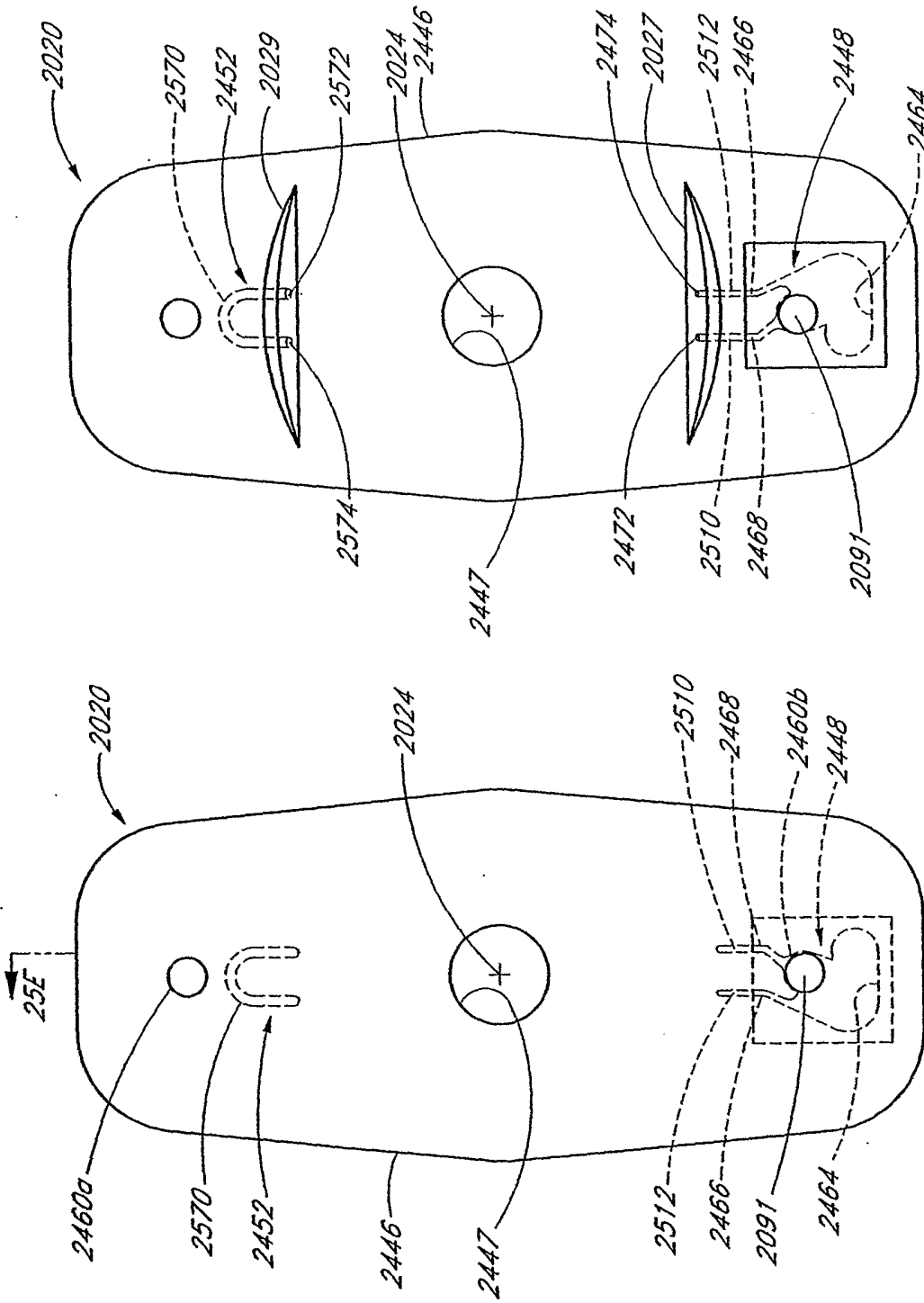

FIG. 25B

FIG. 25A

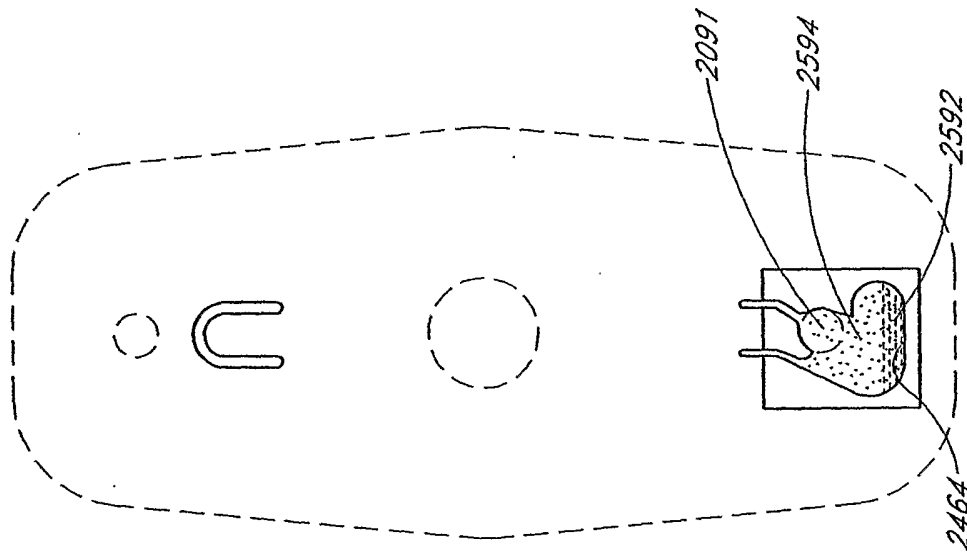

FIG. 25D

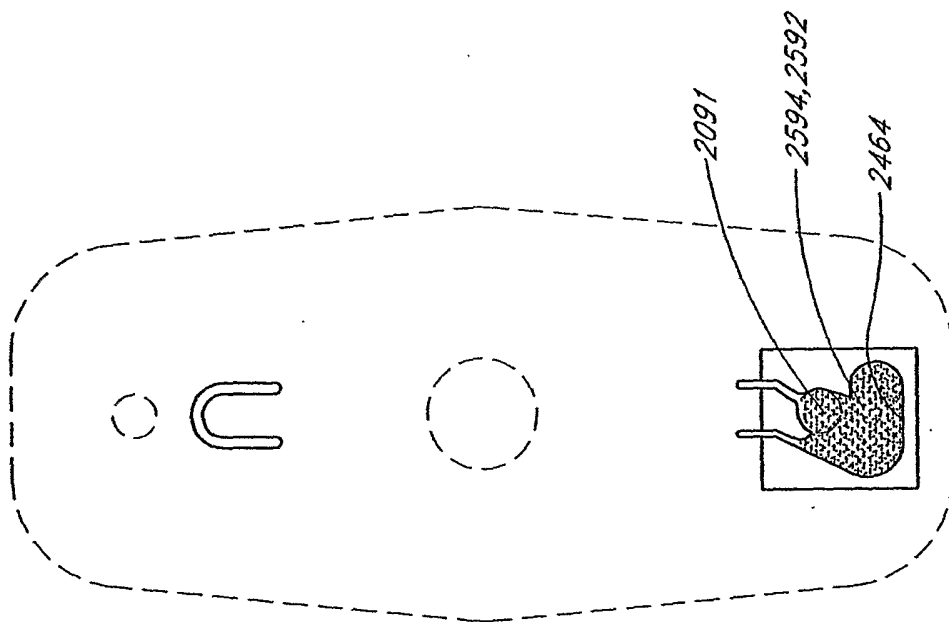

FIG. 25C

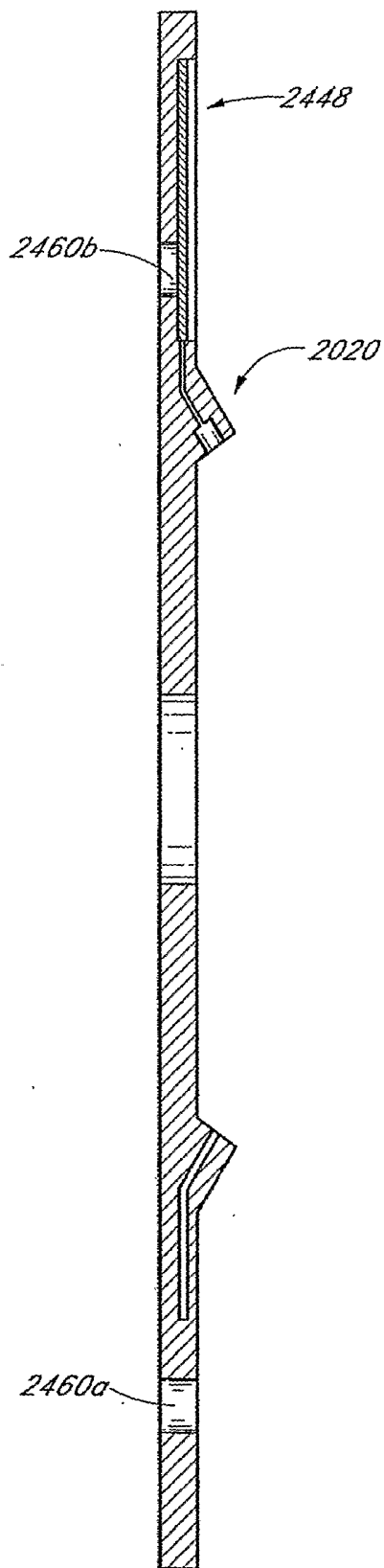

FIG. 25E

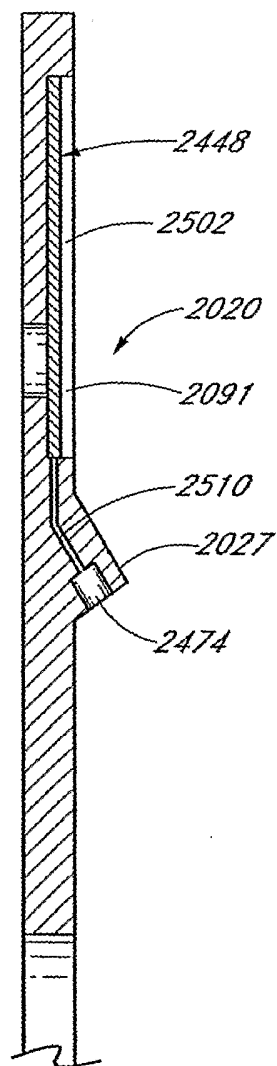

FIG. 25F

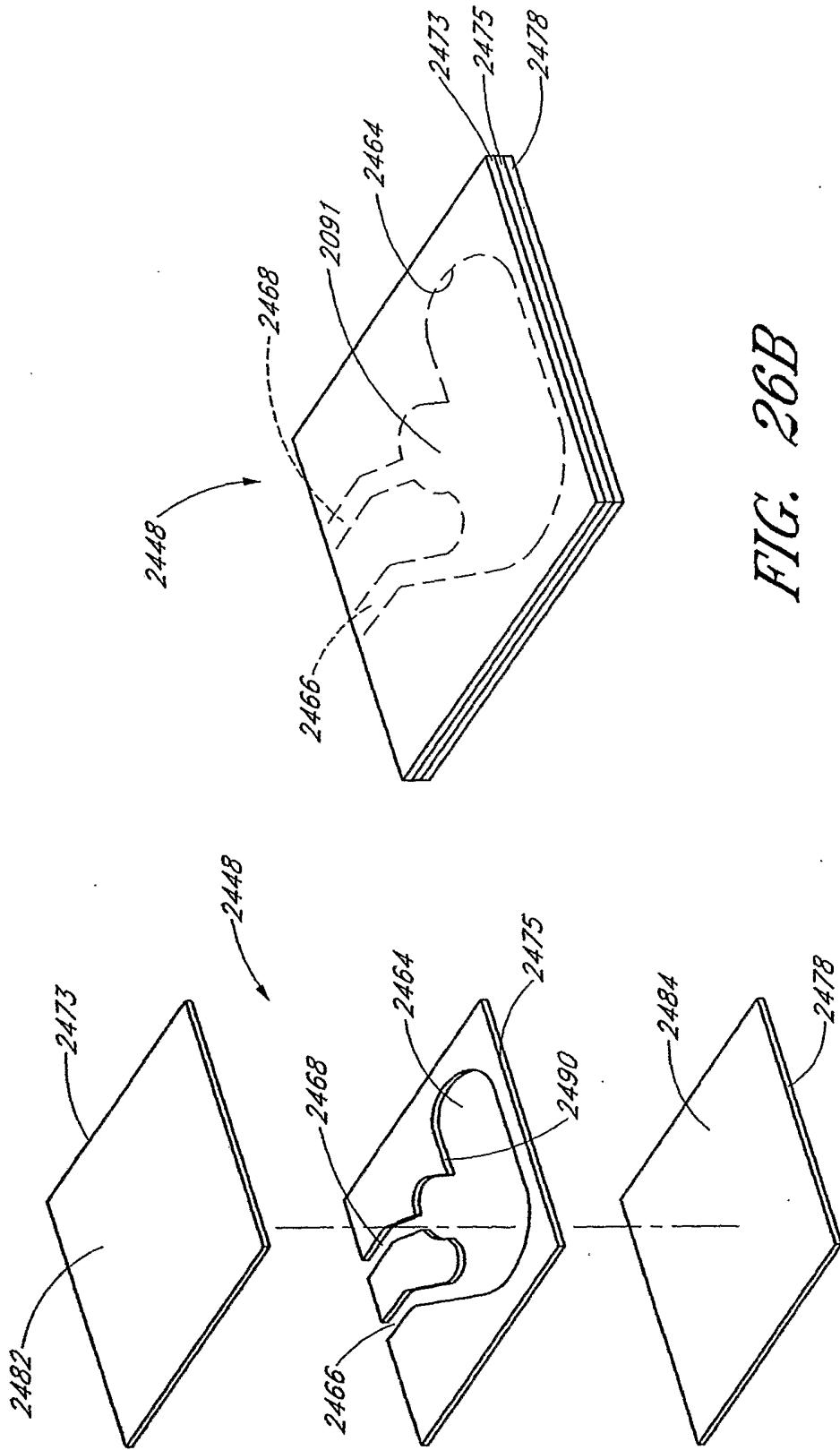

FIG. 26B

FIG. 26A

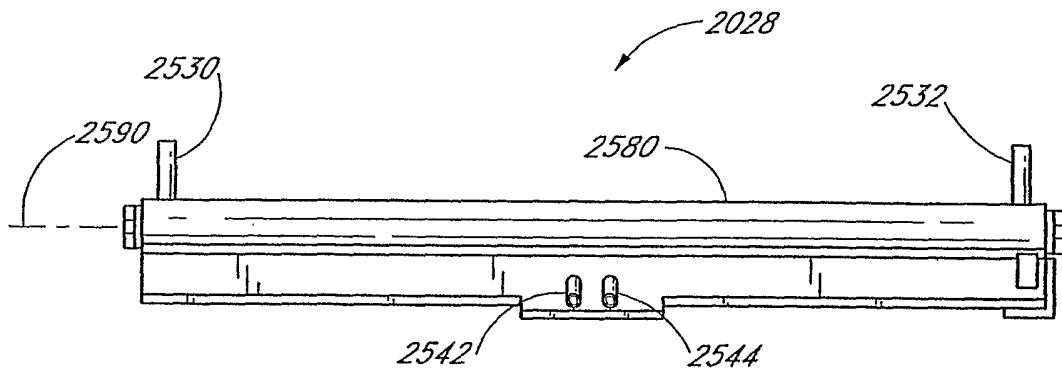

FIG. 27A

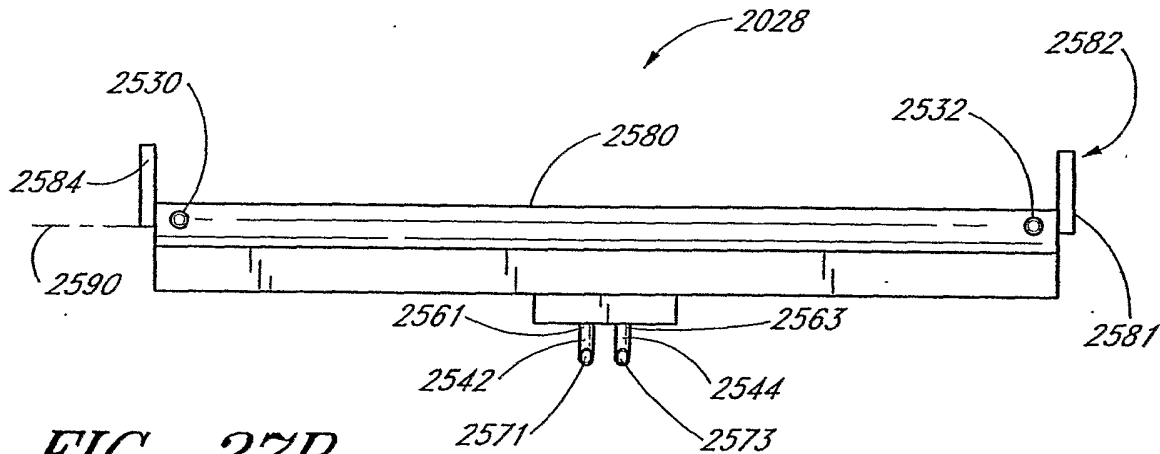

FIG. 27B

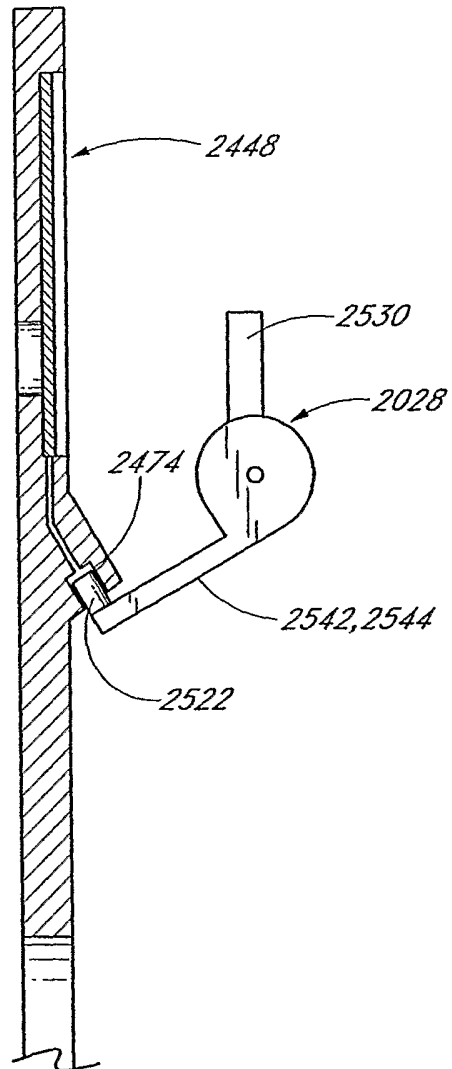

FIG. 27C

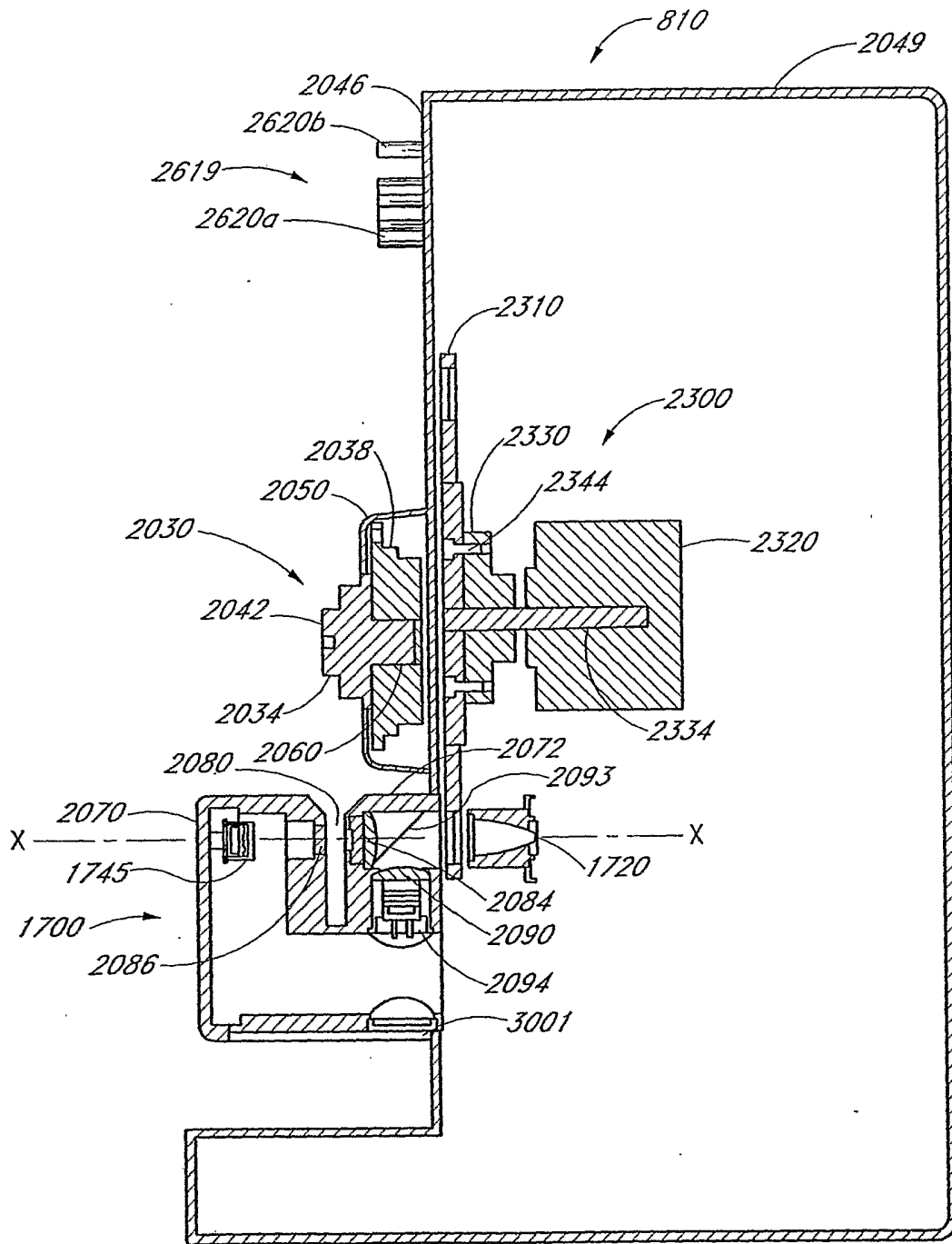

FIG. 28

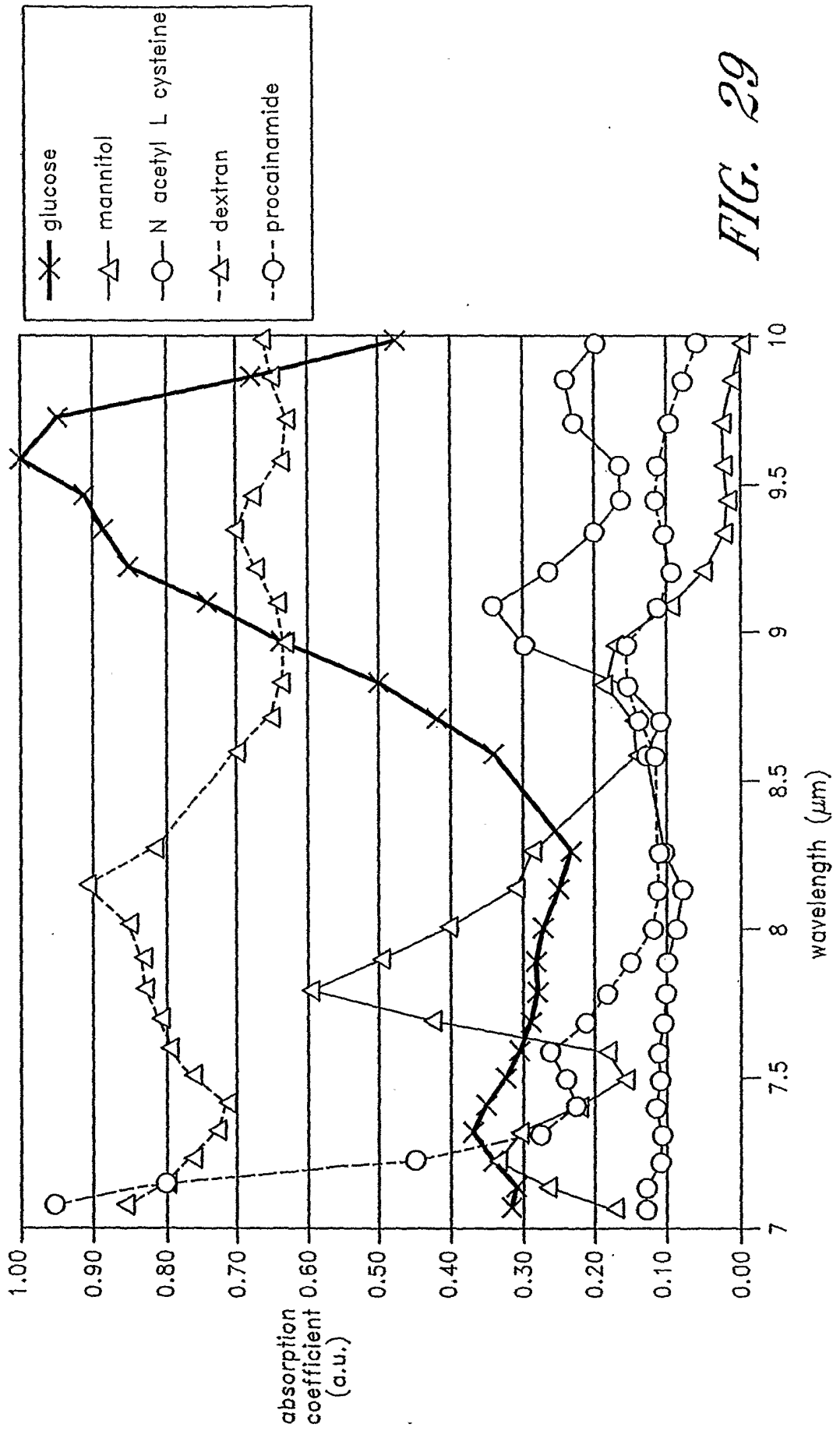

FIG. 29

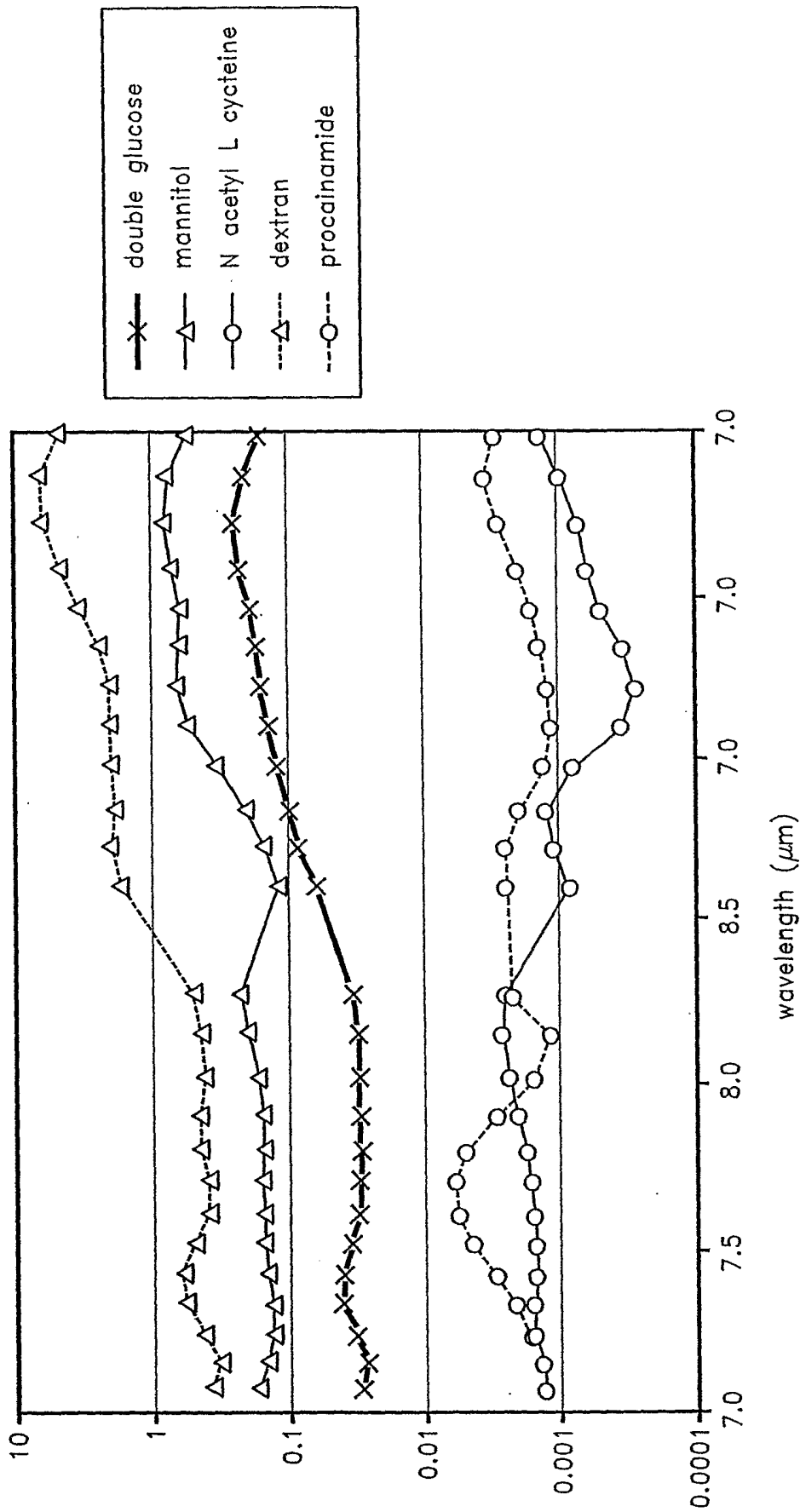

FIG. 30

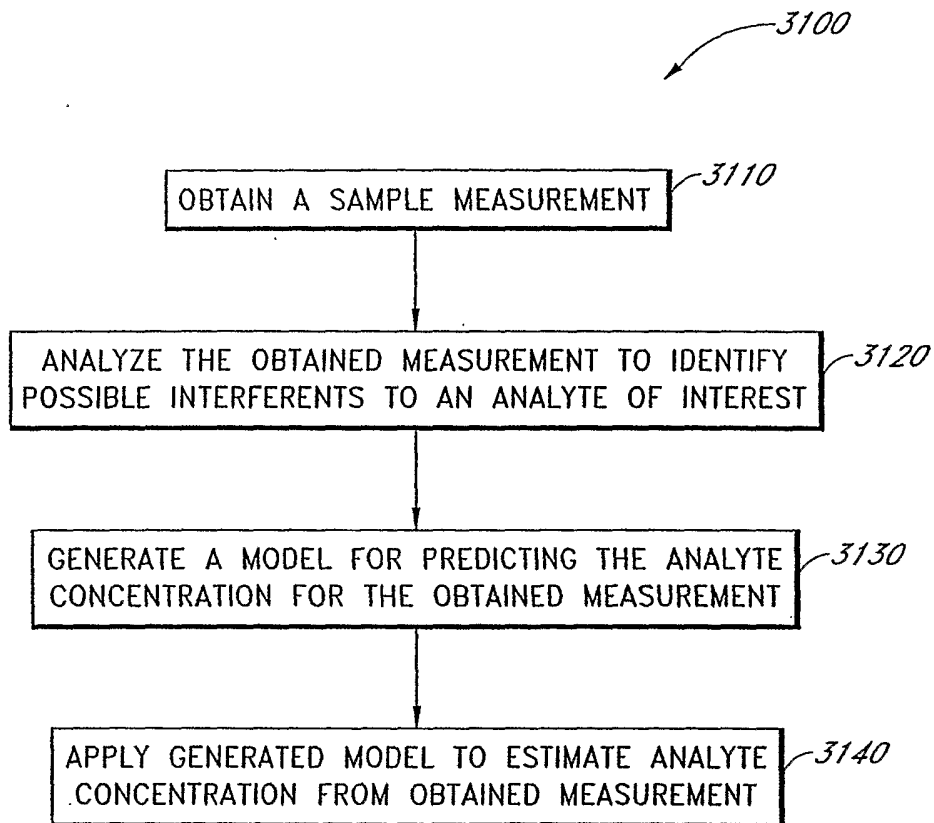

FIG. 31

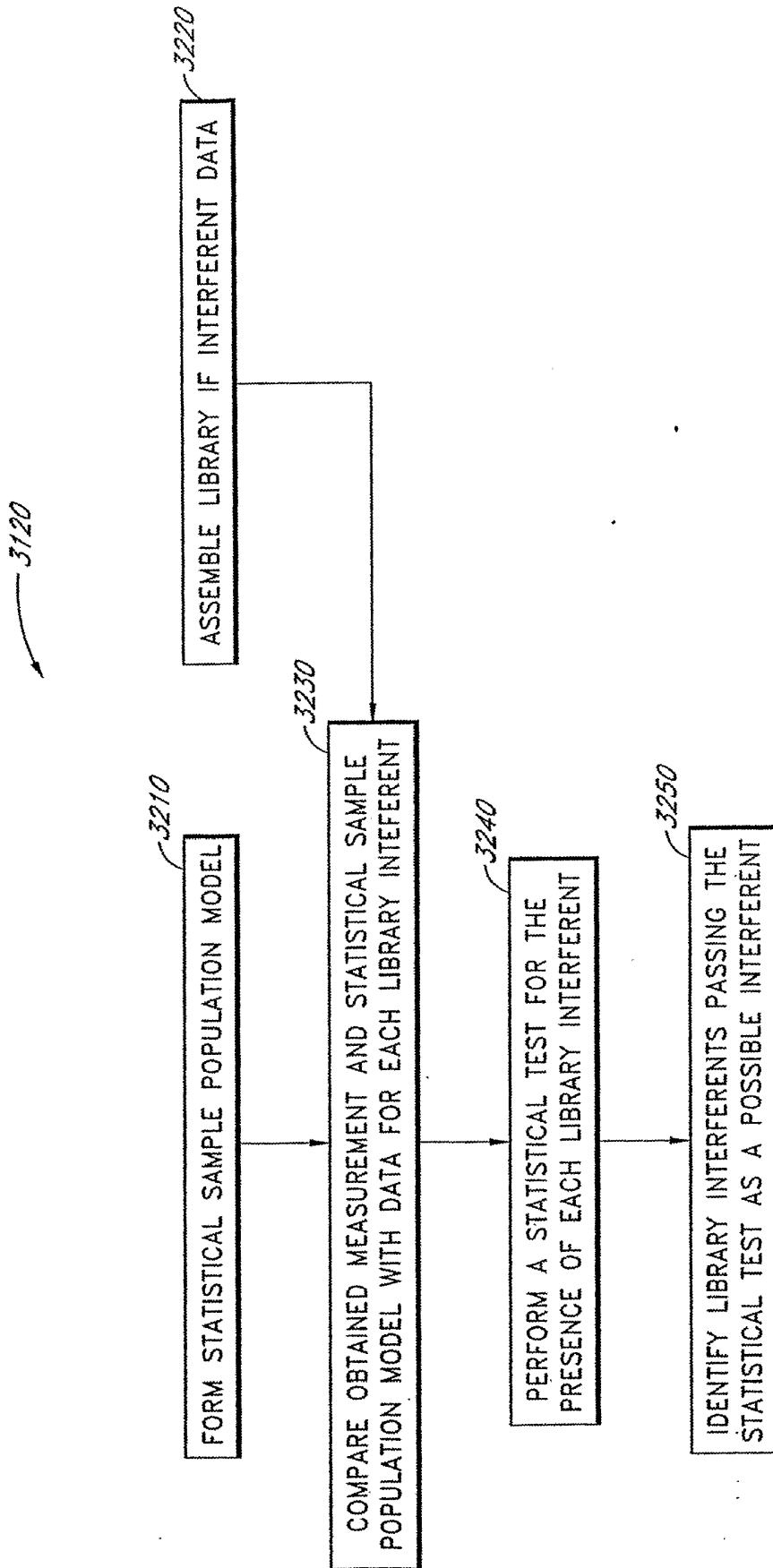

FIG. 32

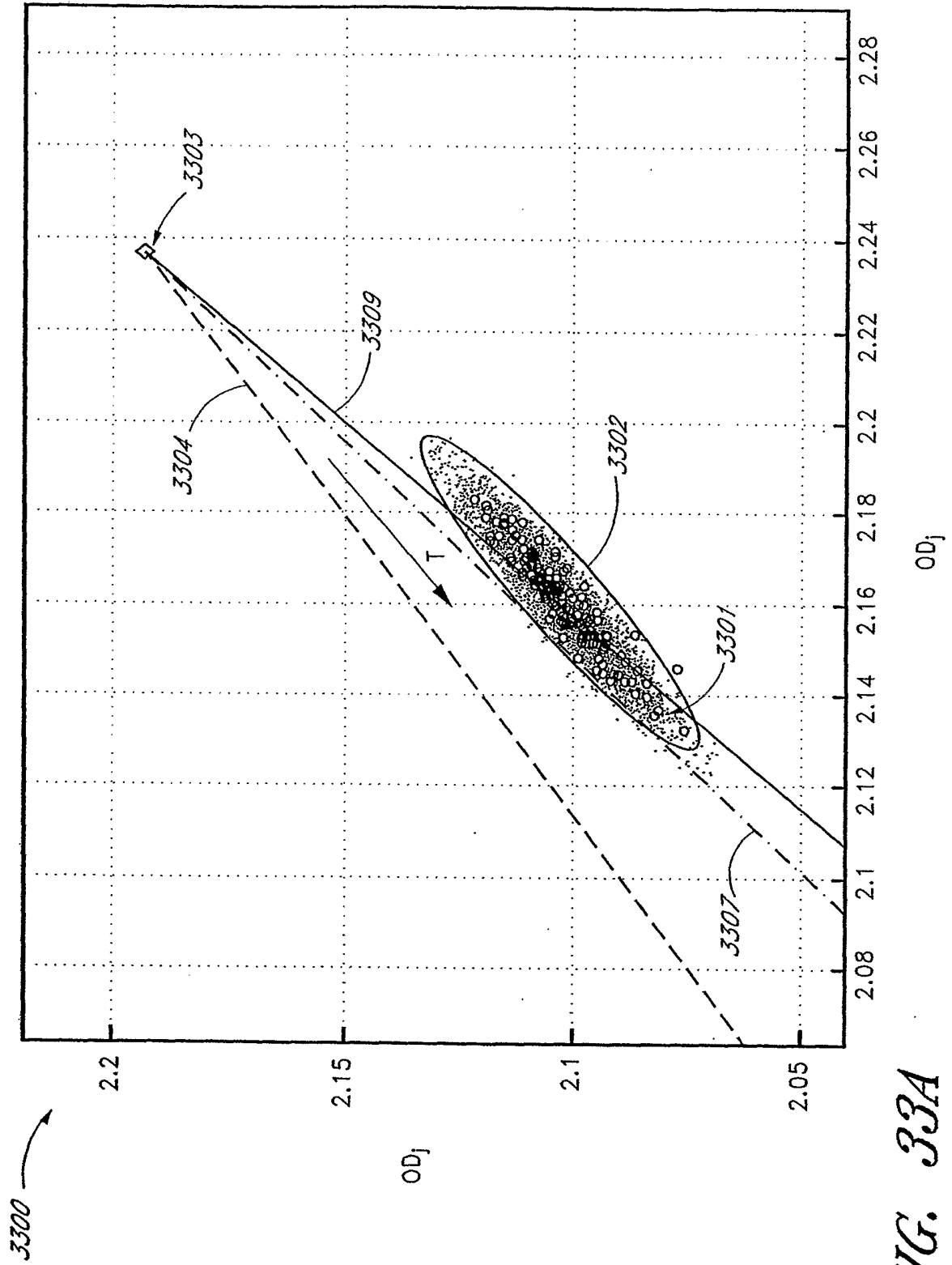

FIG. 33A

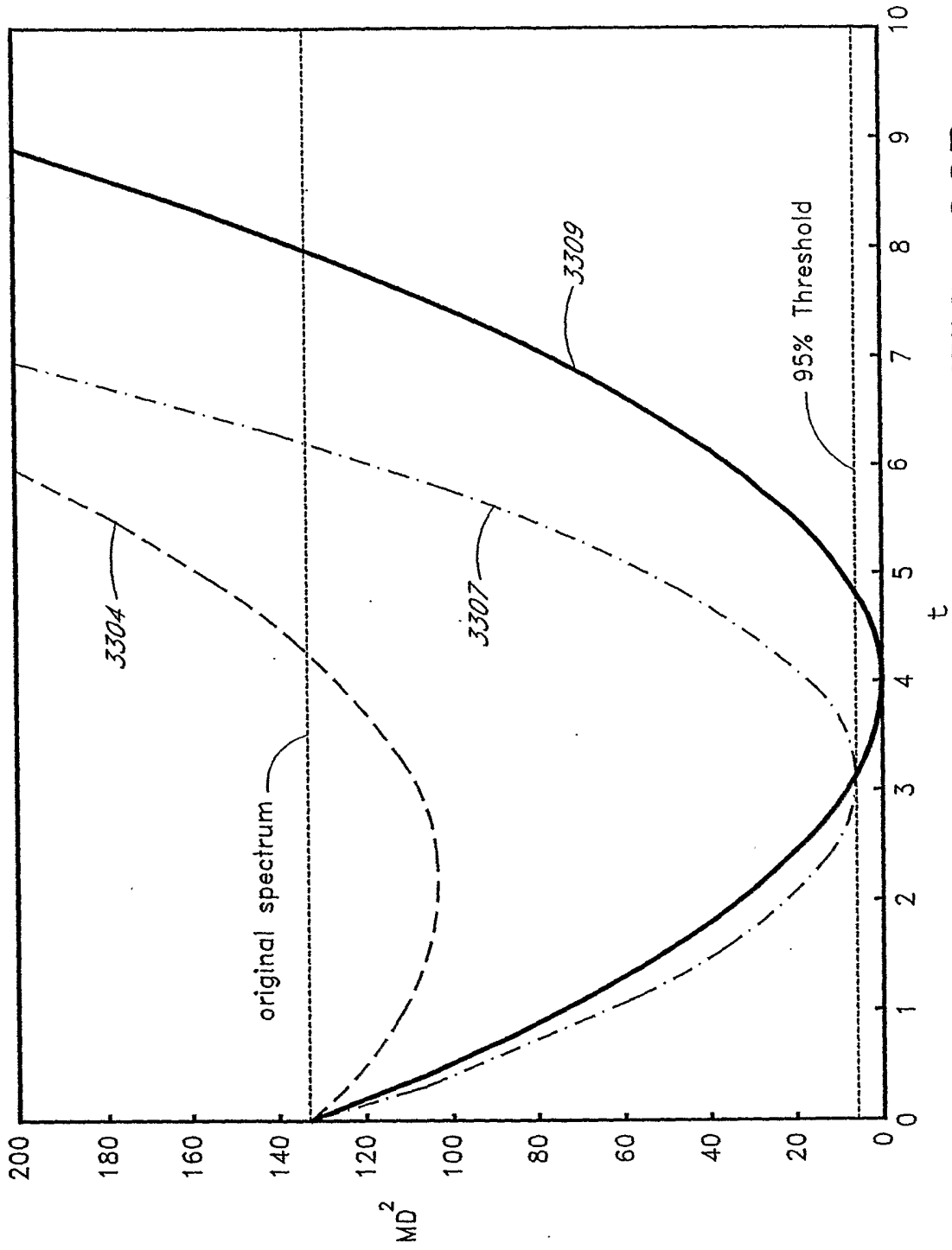

FIG. 33B

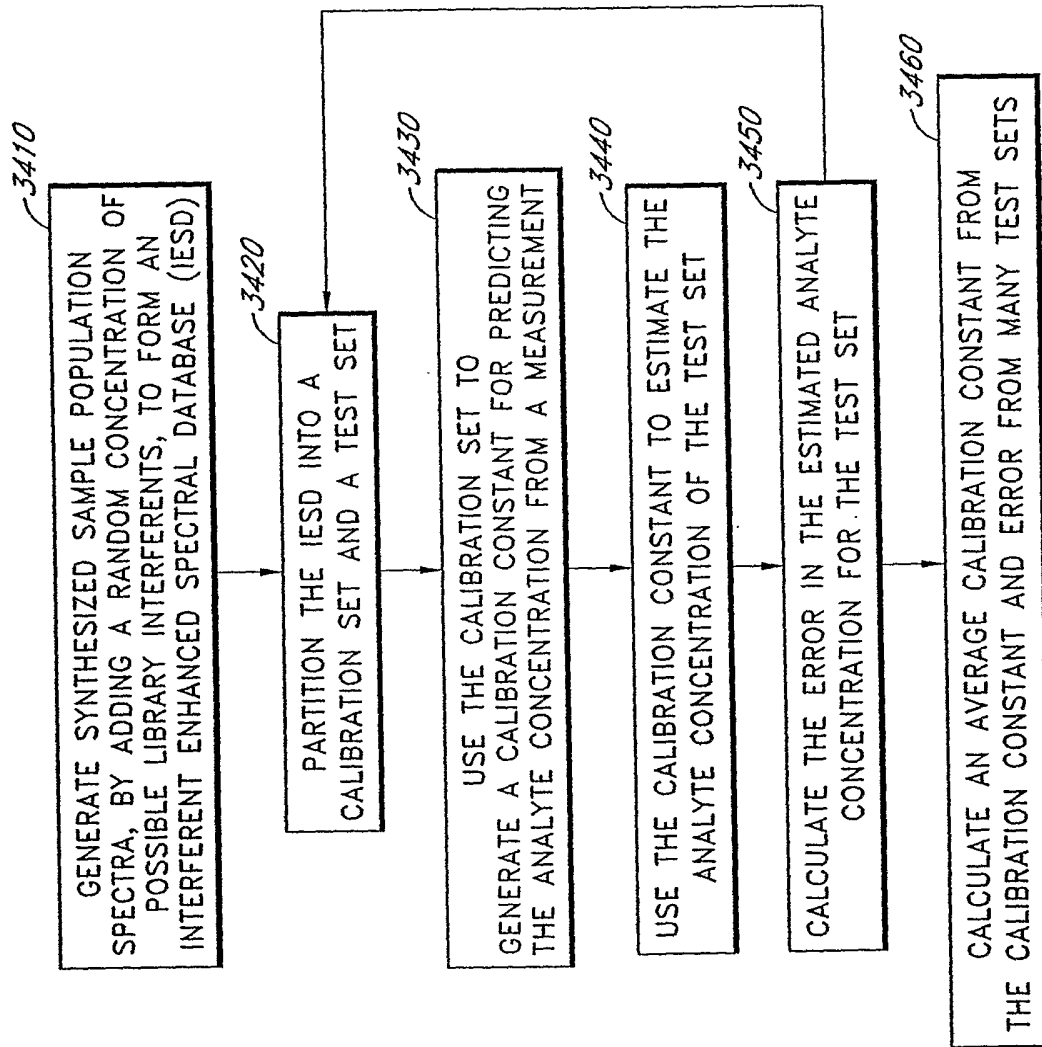

FIG. 34

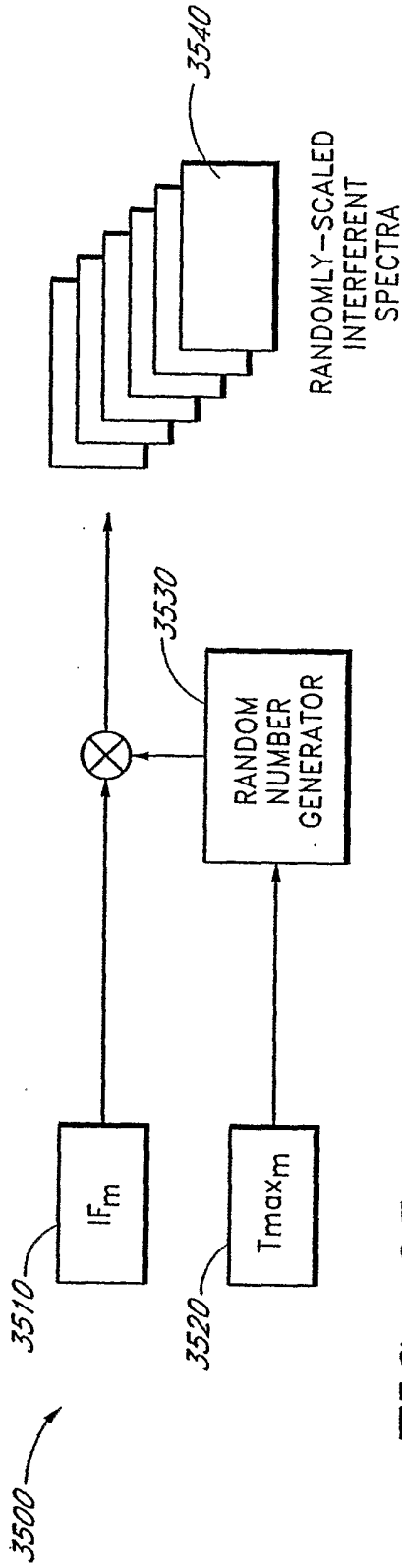

FIG. 35

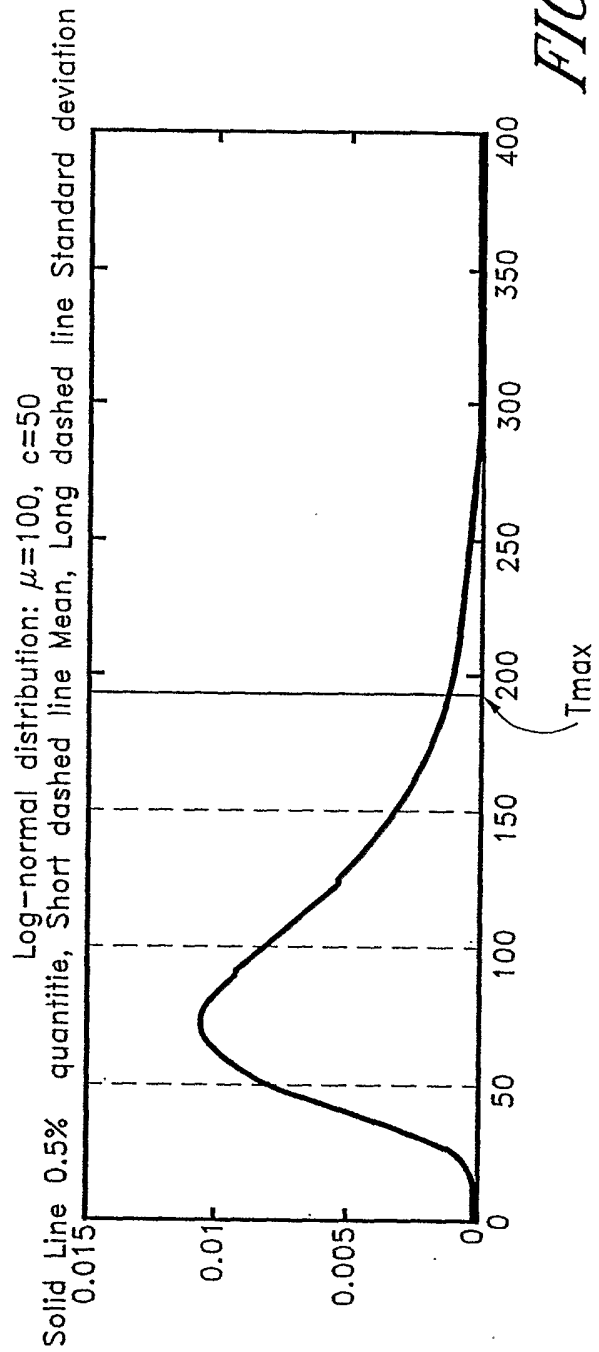

FIG. 36

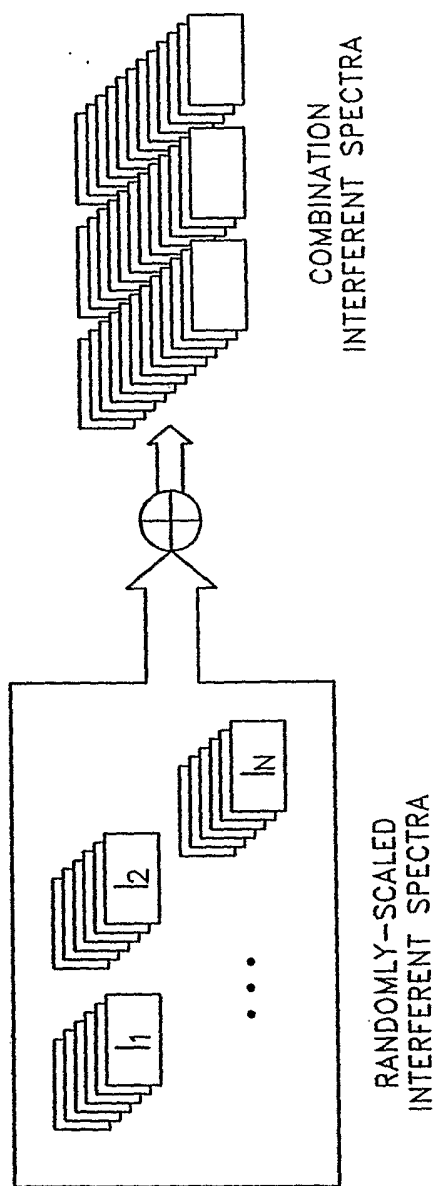

FIG. 37

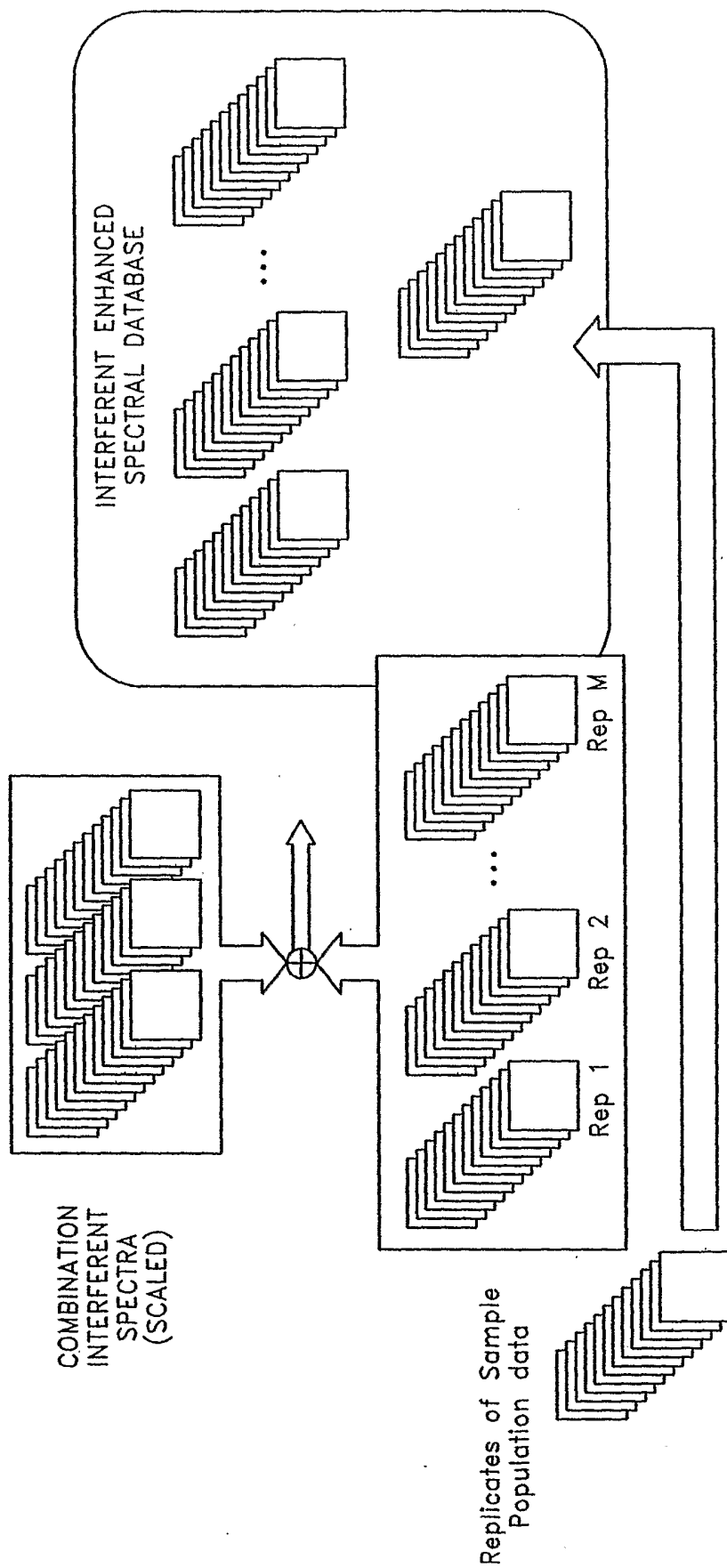

FIG. 38

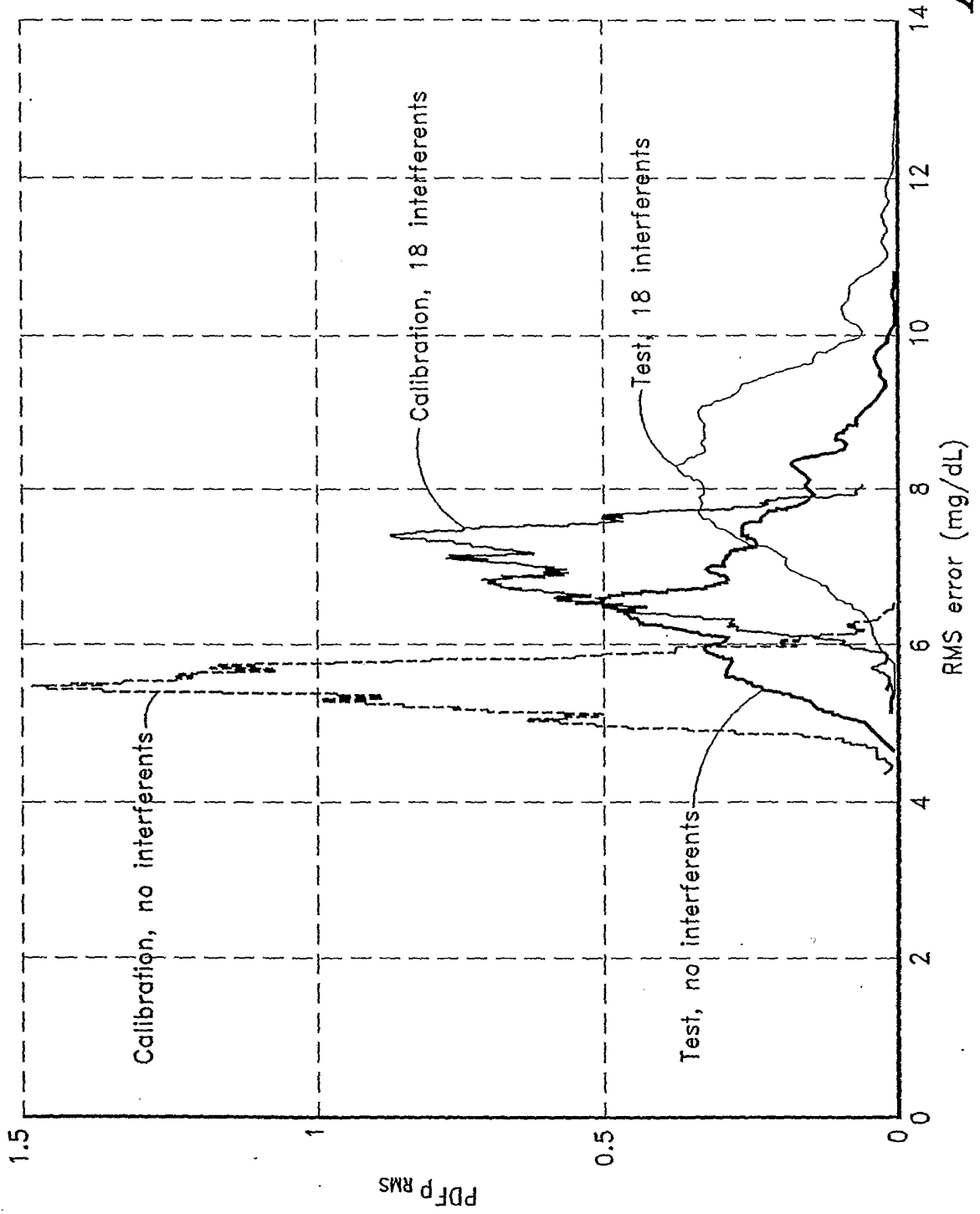

FIG. 39

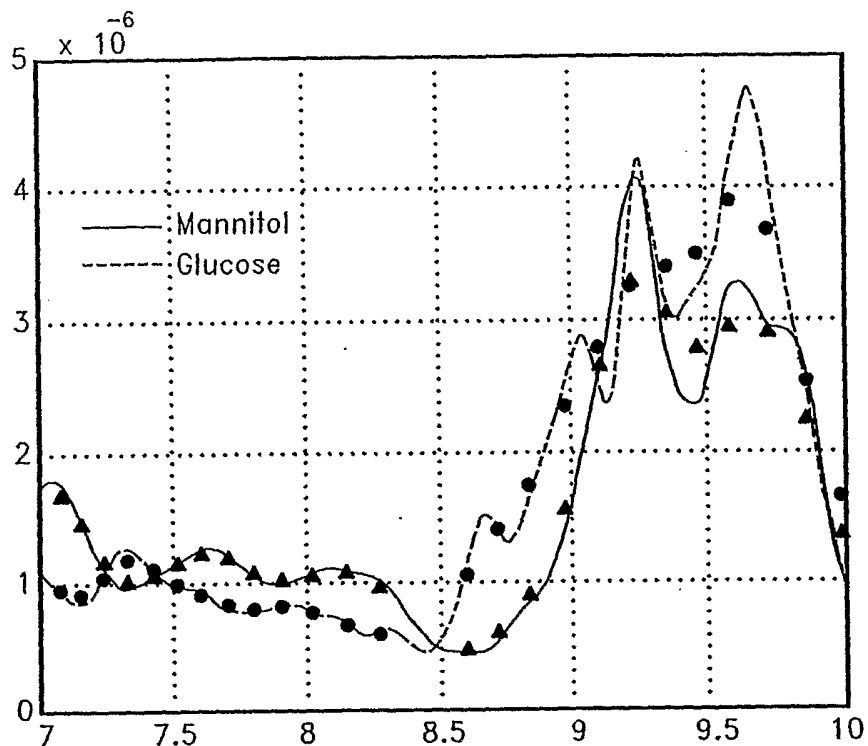

FIG. 40A

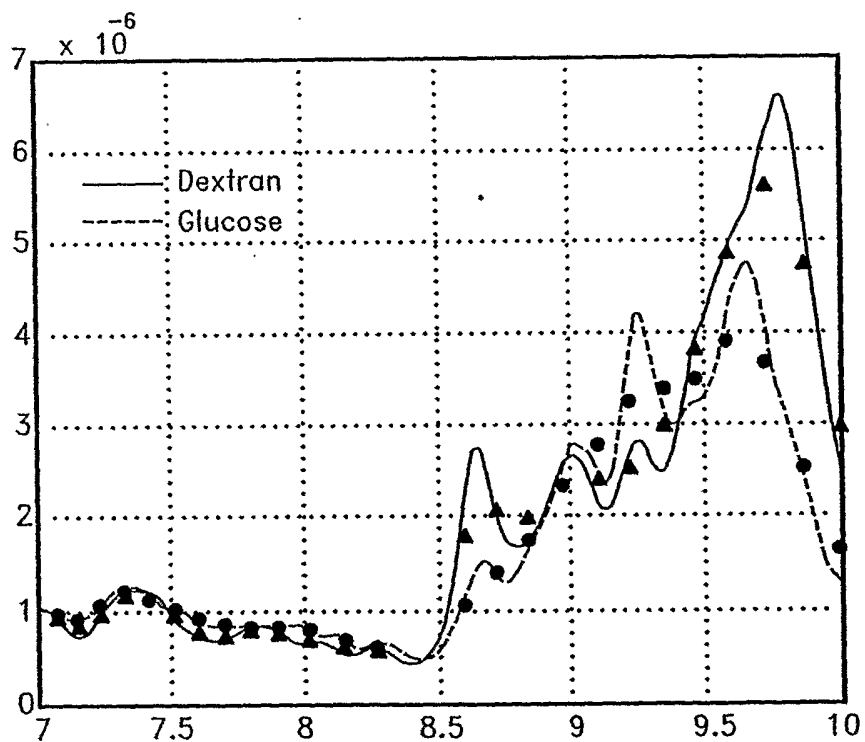

FIG. 40B

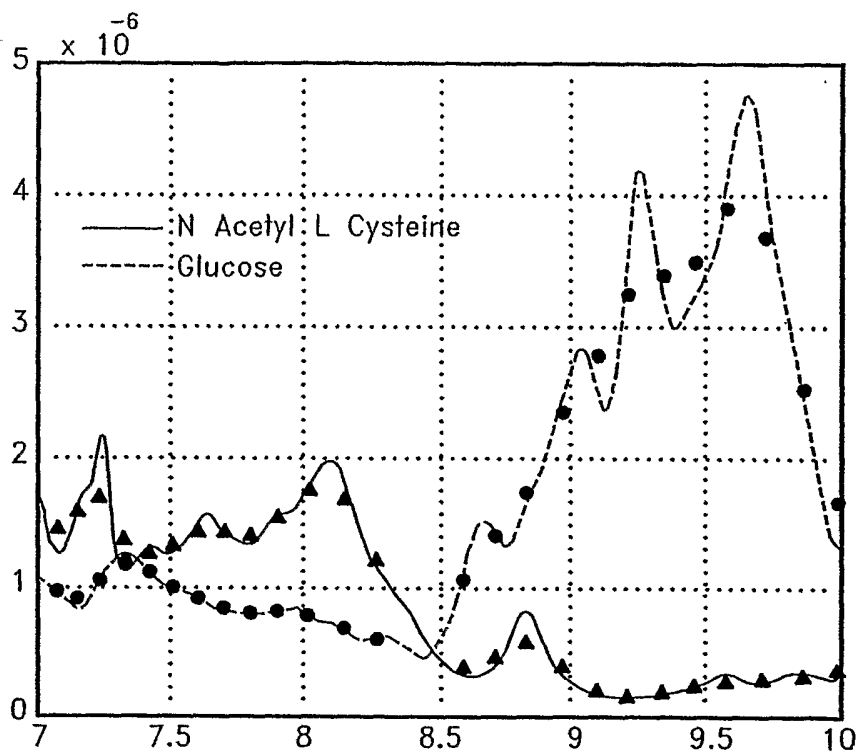

FIG. 40C

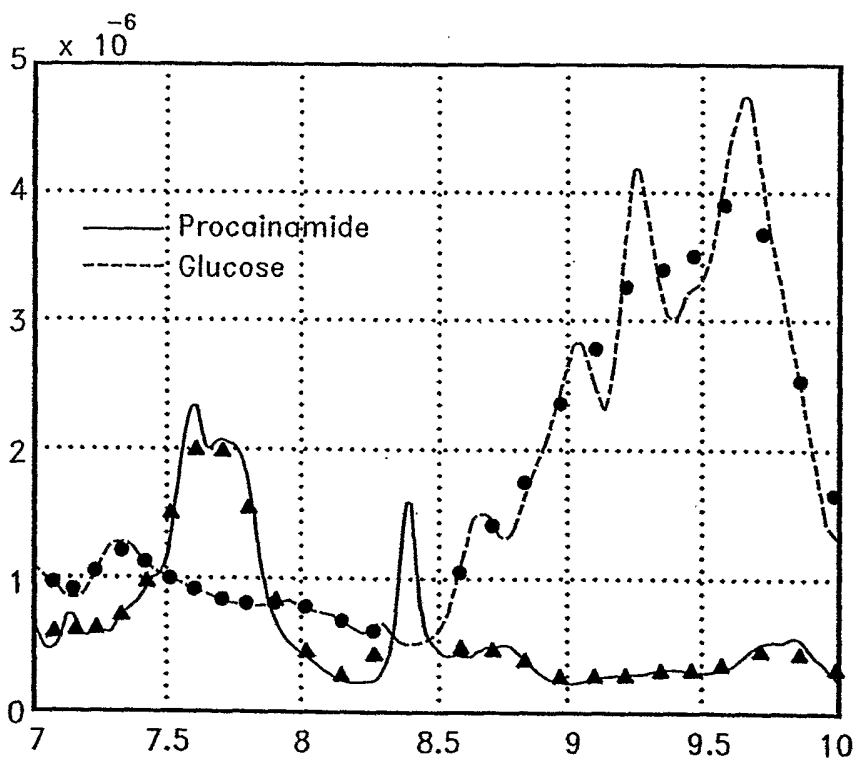

FIG. 40D

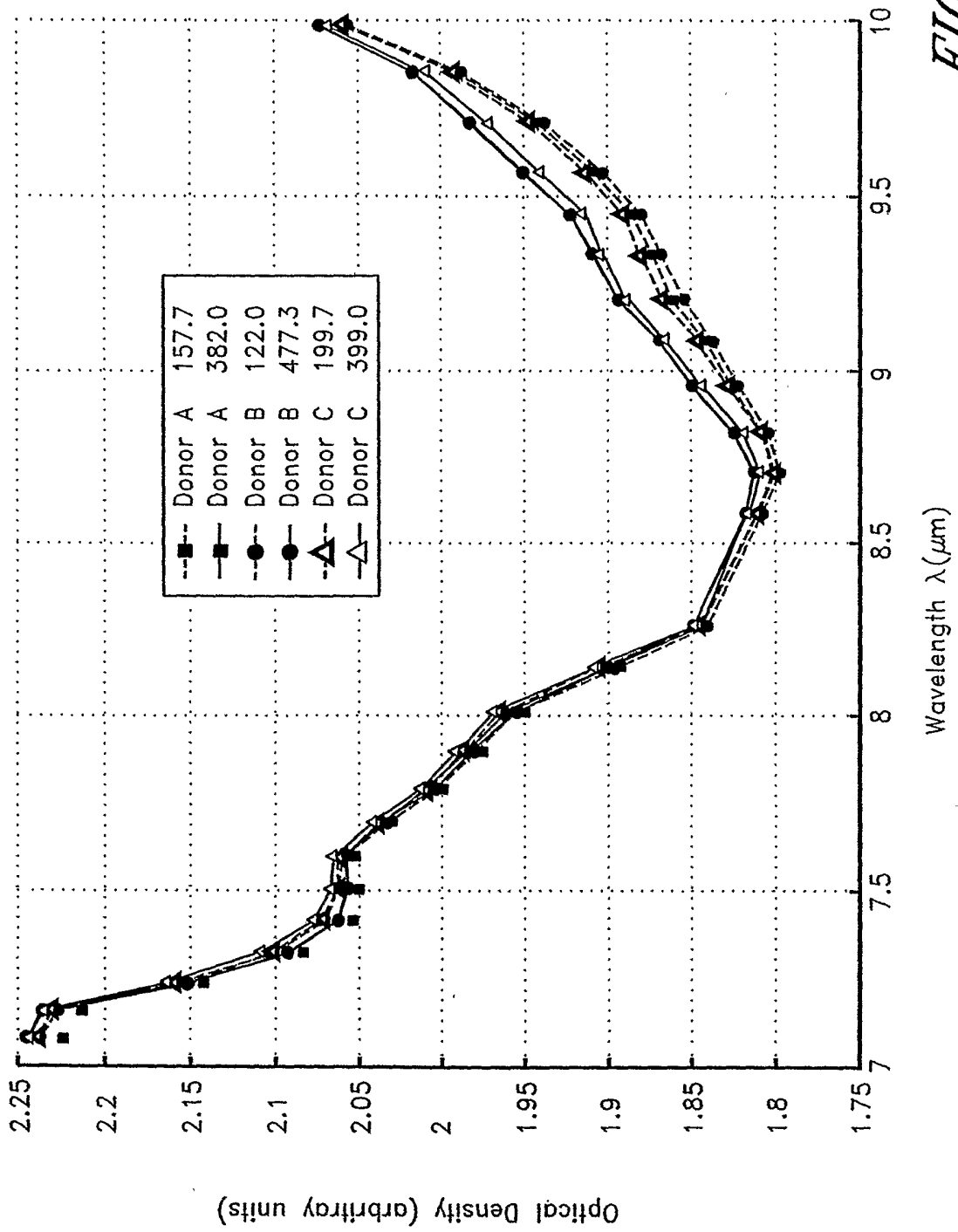

FIG. 41

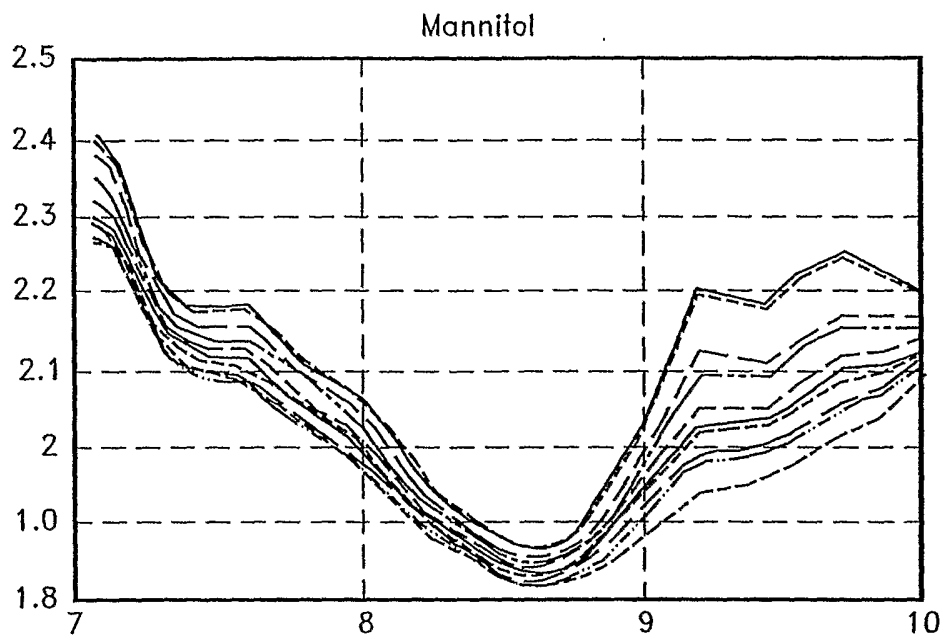

FIG. 42A

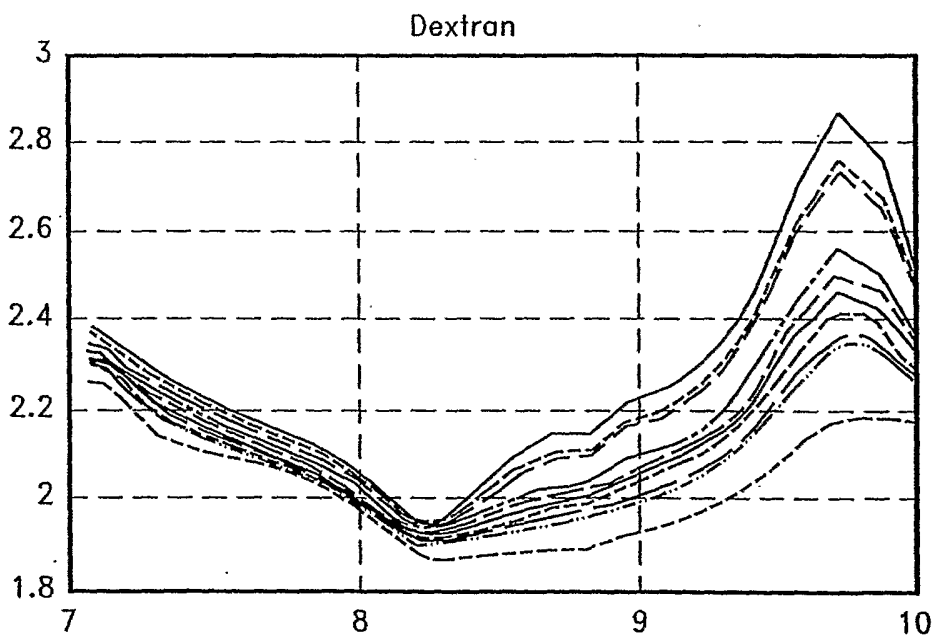

FIG. 42B

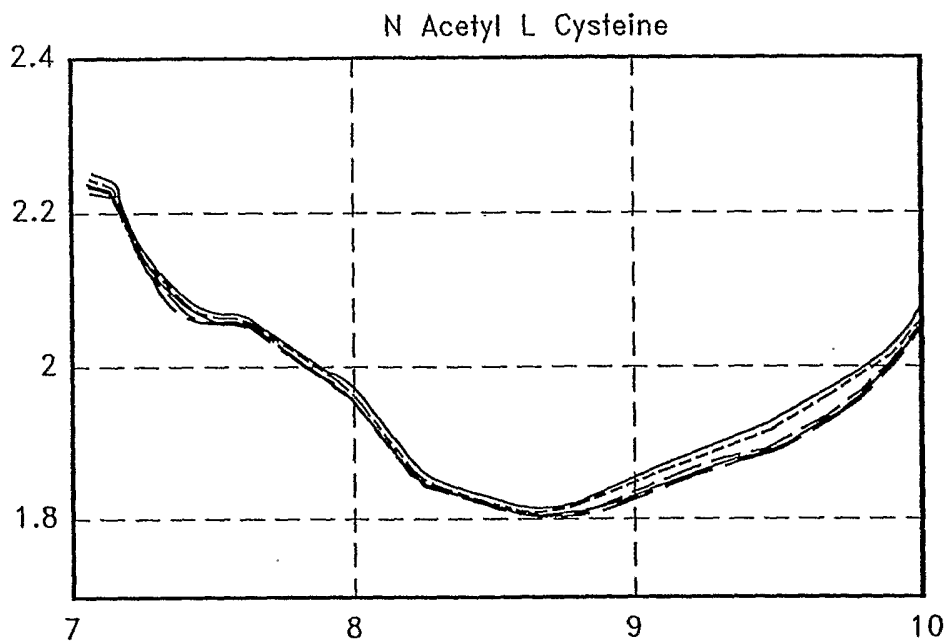

FIG. 42C

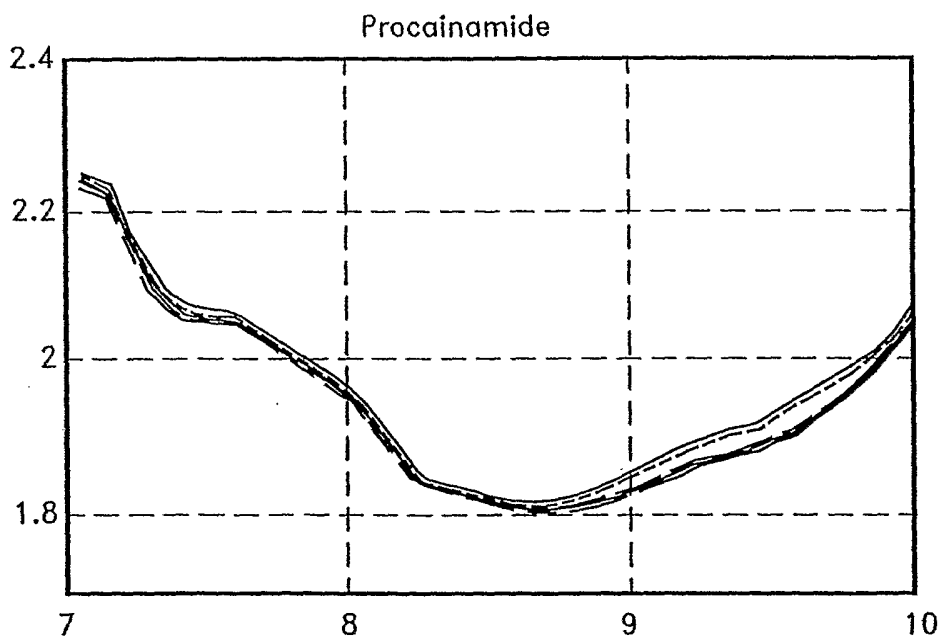

FIG. 42D

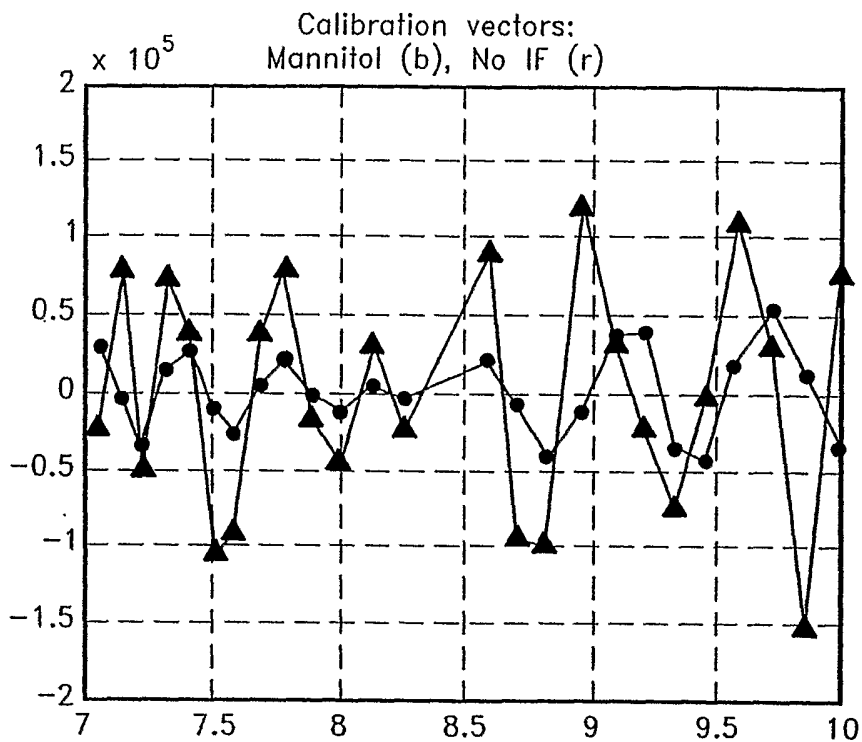

FIG. 43A

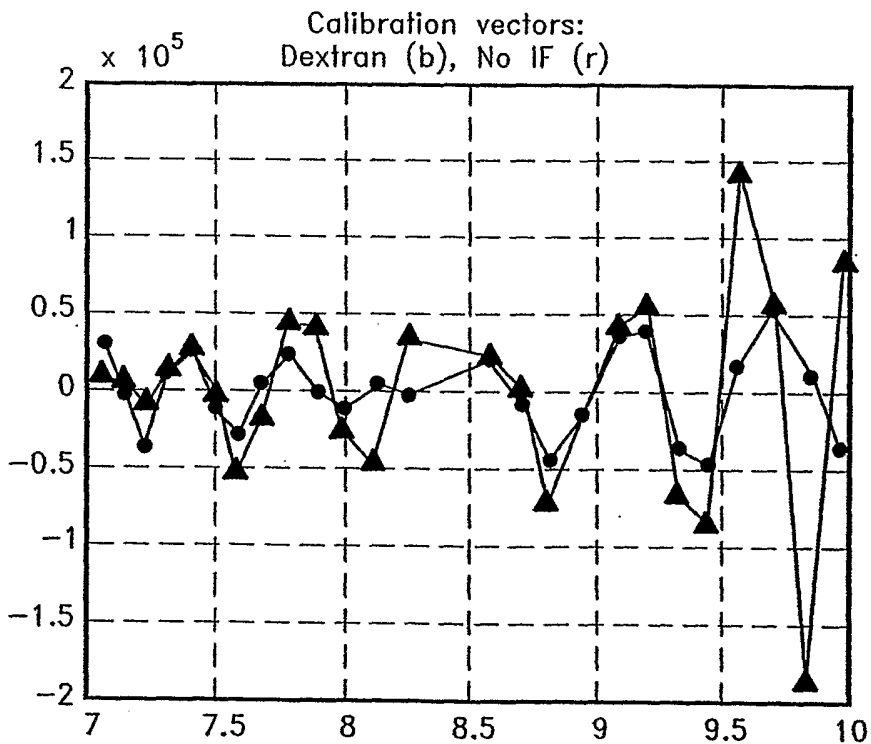

FIG. 43B

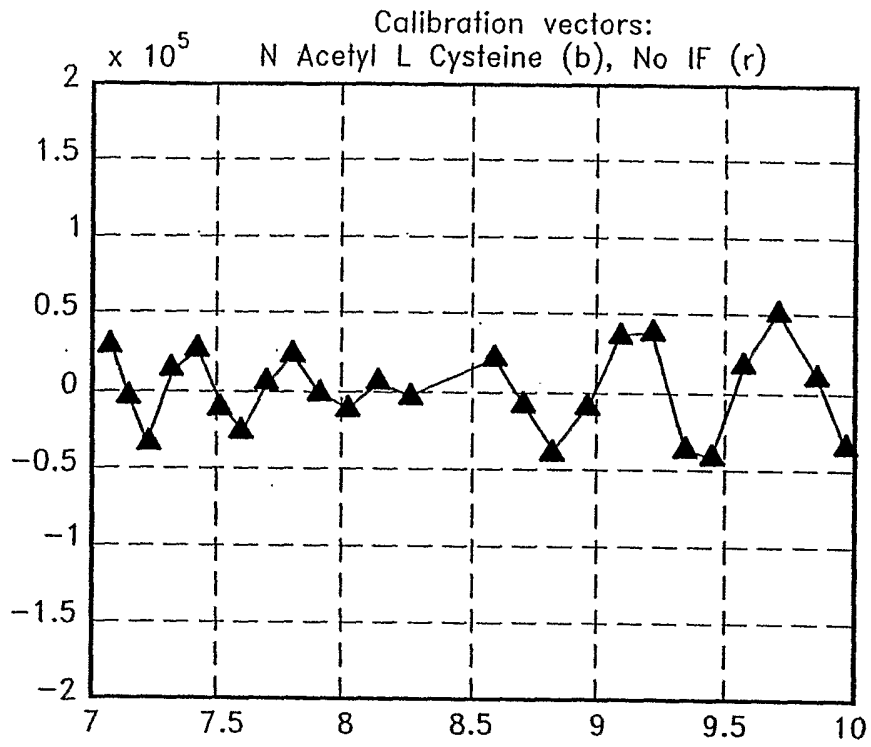

FIG. 43C

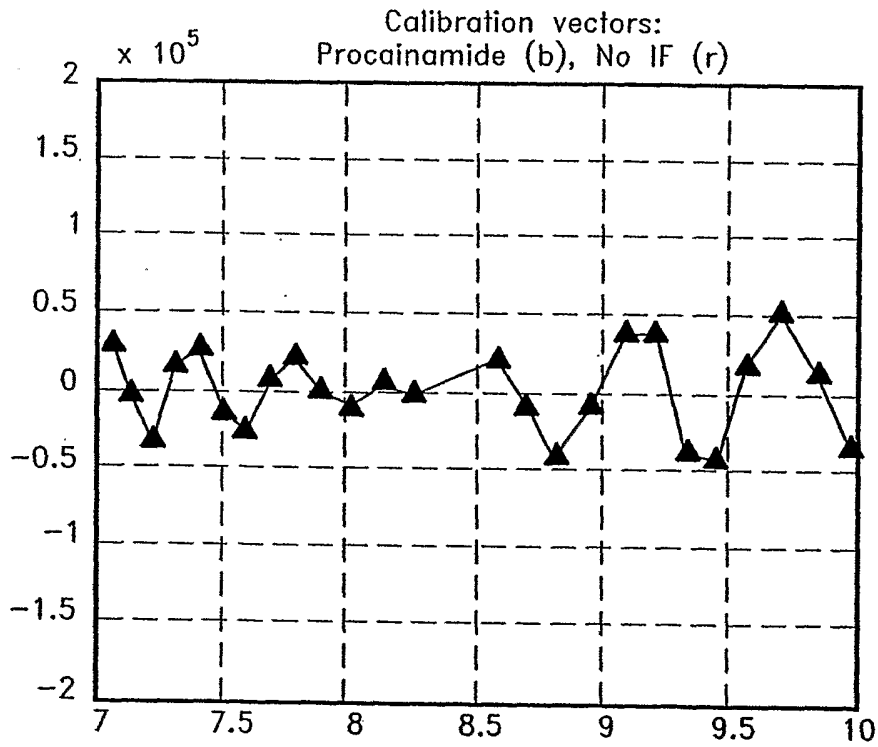

FIG. 43D

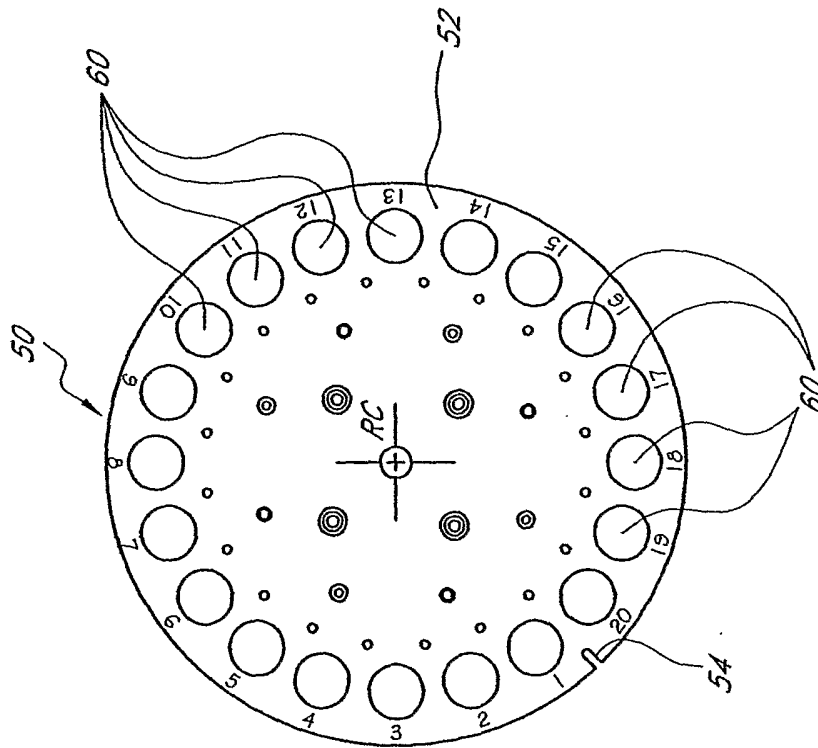

FIG. 45

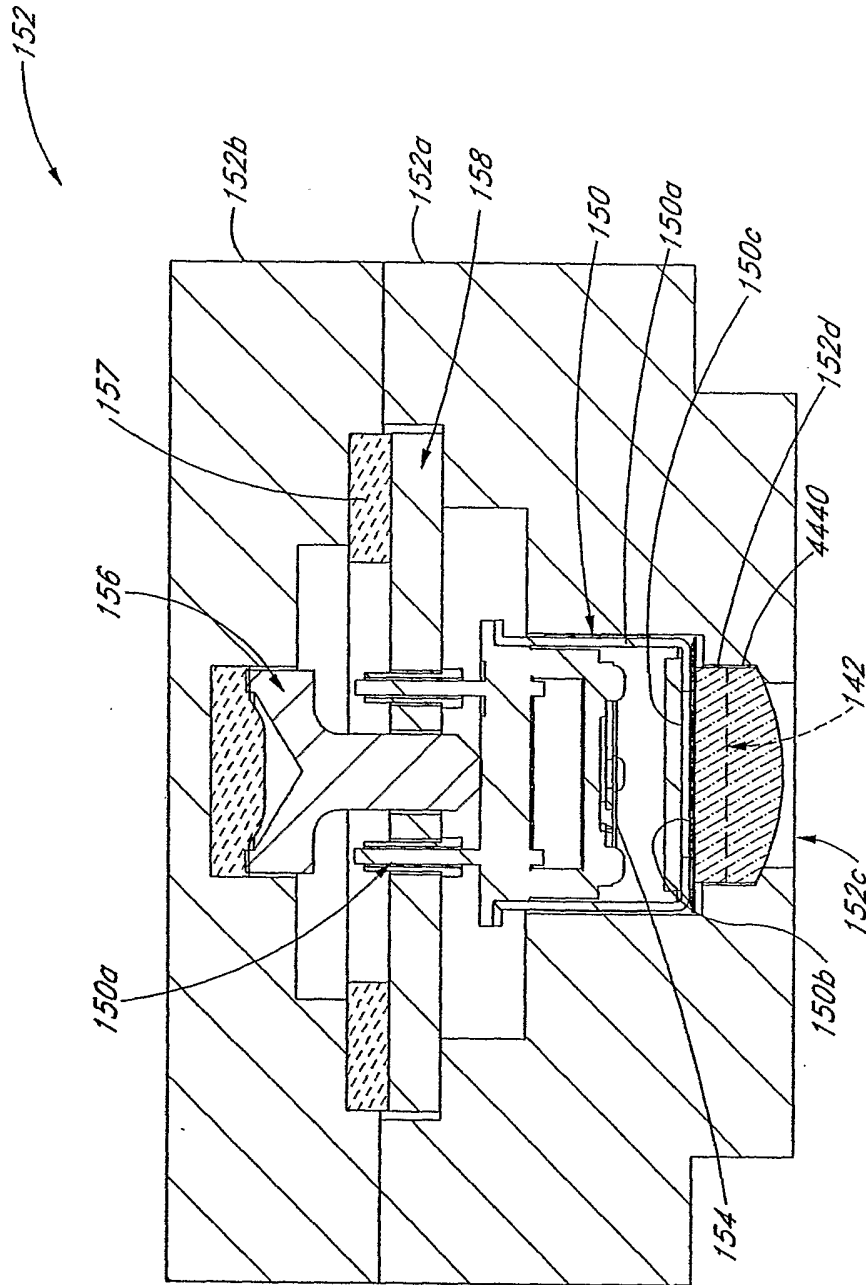

FIG. 47

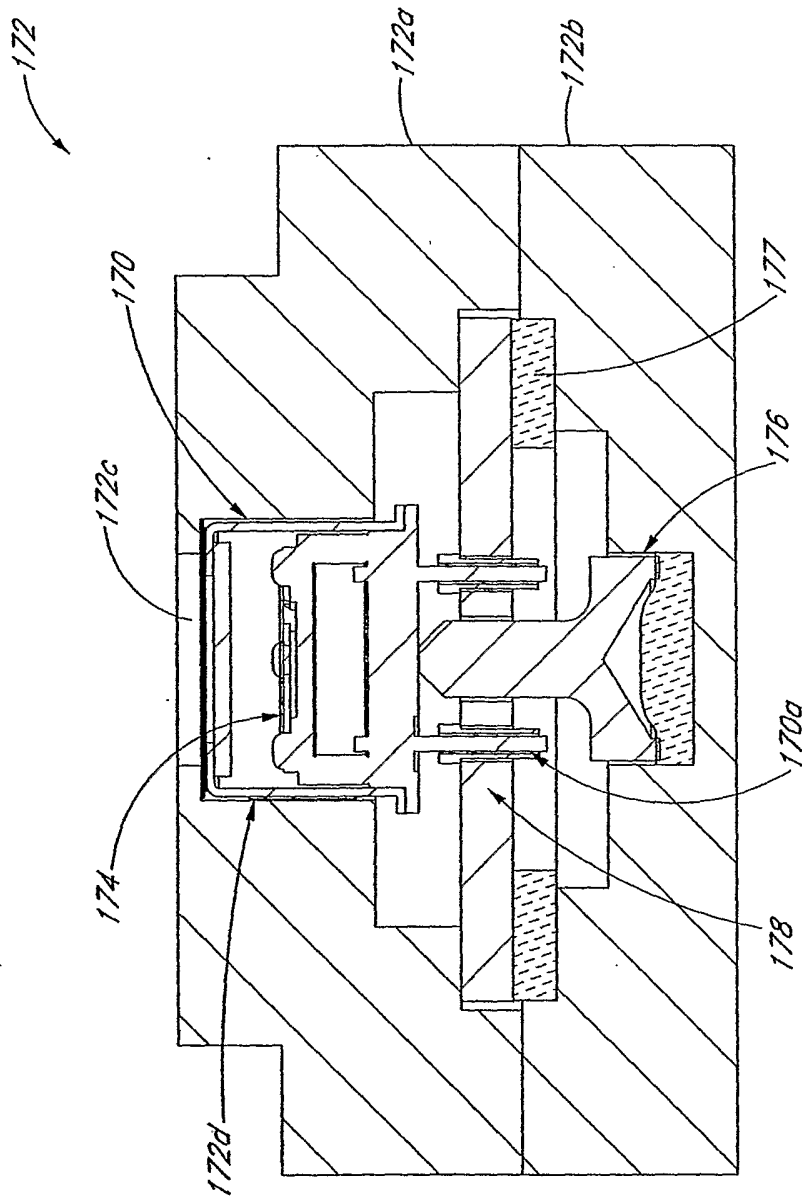

FIG. 48

INTERNATIONAL SEARCH REPORT

International application No
PCT/US2006/005005A. CLASSIFICATION OF SUBJECT MATTER
INV. A61B5/15 A61M1/36

According to International Patent Classification (IPC) or to both national classification and IPC

B. FIELDS SEARCHED

Minimum documentation searched (classification system followed by classification symbols)
A61B A61M

Documentation searched other than minimum documentation to the extent that such documents are included in the fields searched

Electronic data base consulted during the international search (name of data base and, where practical, search terms used)

EPO-Internal

C. DOCUMENTS CONSIDERED TO BE RELEVANT

Category*	Citation of document, with indication, where appropriate, of the relevant passages	Relevant to claim No.
X	US 4 657 529 A (PRINCE ET AL) 14 April 1987 (1987-04-14) column 4, line 3 - column 5, line 3	1-38, 51-68, 83-86
X	US 4 974 592 A (BRANCO ET AL) 4 December 1990 (1990-12-04) column 5, line 51 - column 6, line 9 column 7, lines 16-60 column 8, line 14 - column 9, line 25	1-26

 Further documents are listed in the continuation of Box C. See patent family annex.

* Special categories of cited documents :

A document defining the general state of the art which is not considered to be of particular relevance

E earlier document but published on or after the international filing date

L document which may throw doubts on priority claim(s) or which is cited to establish the publication date of another citation or other special reason (as specified)

O document referring to an oral disclosure, use, exhibition or other means

P document published prior to the international filing date but later than the priority date claimed

T later document published after the international filing date or priority date and not in conflict with the application but cited to understand the principle or theory underlying the invention

X document of particular relevance; the claimed invention cannot be considered novel or cannot be considered to involve an inventive step when the document is taken alone

Y document of particular relevance; the claimed invention cannot be considered to involve an inventive step when the document is combined with one or more other such documents, such combination being obvious to a person skilled in the art.

& document member of the same patent family

Date of the actual completion of the international search

23 June 2006

Date of mailing of the international search report

04/07/2006

Name and mailing address of the ISA/

European Patent Office, P.B. 5818 Patentlaan 2
NL - 2280 HV Rijswijk
Tel. (+31-70) 340-2040, Tx. 31 651 epo nl,
Fax: (+31-70) 340-3016

Authorized officer

Martelli, L

INTERNATIONAL SEARCH REPORT

International application No.
PCT/US2006/005005

Box II Observations where certain claims were found unsearchable (Continuation of item 2 of first sheet)

This International Search Report has not been established in respect of certain claims under Article 17(2)(a) for the following reasons:

1. Claims Nos.: 39-50, 69-82
because they relate to subject matter not required to be searched by this Authority, namely:
Rule 39.1(iv) PCT - Method for treatment of the human or animal body by surgery. All the method claims include the steps of sampling and injecting fluid from or into the patient.
2. Claims Nos.:
because they relate to parts of the International Application that do not comply with the prescribed requirements to such an extent that no meaningful International Search can be carried out, specifically:
3. Claims Nos.:
because they are dependent claims and are not drafted in accordance with the second and third sentences of Rule 6.4(a).

Box III Observations where unity of invention is lacking (Continuation of item 3 of first sheet)

This International Searching Authority found multiple inventions in this international application, as follows:

1. As all required additional search fees were timely paid by the applicant, this International Search Report covers all searchable claims.
2. As all searchable claims could be searched without effort justifying an additional fee, this Authority did not invite payment of any additional fee.
3. As only some of the required additional search fees were timely paid by the applicant, this International Search Report covers only those claims for which fees were paid, specifically claims Nos.:
4. No required additional search fees were timely paid by the applicant. Consequently, this International Search Report is restricted to the invention first mentioned in the claims; it is covered by claims Nos.:

Remark on Protest

- The additional search fees were accompanied by the applicant's protest.
- No protest accompanied the payment of additional search fees.

INTERNATIONAL SEARCH REPORT

Information on patent family members

International application No
PCT/US2006/005005

Patent document cited in search report	Publication date	Patent family member(s)	Publication date
US 4657529	A	14-04-1987	NONE
US 4974592	A	04-12-1990	ES 2019733 A6 01-07-1991 FR 2638960 A1 18-05-1990 GB 2224851 A 16-05-1990 JP 2189133 A 25-07-1990