

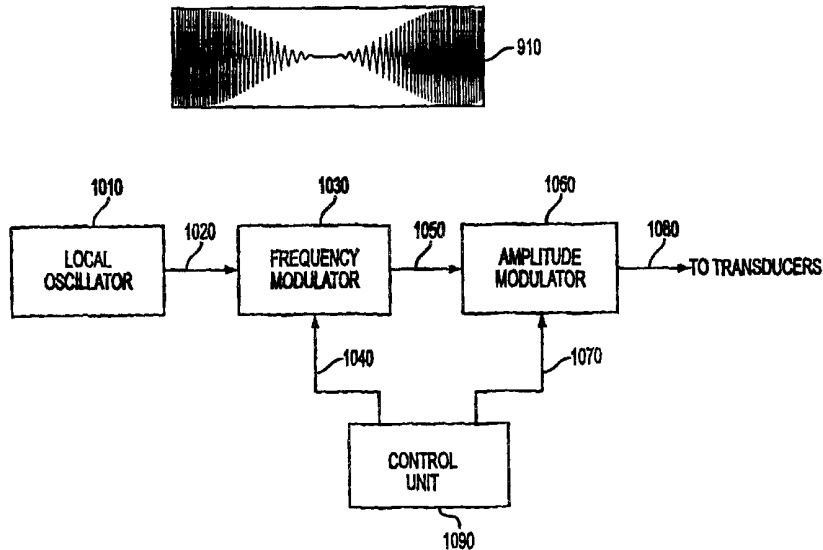

INTERNATIONAL APPLICATION PUBLISHED UNDER THE PATENT COOPERATION TREATY (PCT)

<p>(51) International Patent Classification <sup>7</sup> : A61H 23/02, 1/00, A47C 21/00</p>	<p>A1</p>	<p>(11) International Publication Number: <b>WO 00/67693</b> (43) International Publication Date: 16 November 2000 (16.11.00)</p>
<p>(21) International Application Number: PCT/US00/12912 (22) International Filing Date: 11 May 2000 (11.05.00) (30) Priority Data: 60/133,845 12 May 1999 (12.05.99) US (63) Related by Continuation (CON) or Continuation-in-Part (CIP) to Earlier Application US 60/133,845 (CIP) Filed on 12 May 1999 (12.05.99)  (71)(72) Applicants and Inventors: LENHARDT, Martin, L. [US/US]; 1608 Mouring Lane, Hayes, VA 23072 (US). MADSEN, Alan, G. [US/US]; 15-H Belles Cove Drive, Poquoson, VA 23662-1566 (US).  (74) Agent: ISACSON, John, P.; Foley &amp; Lardner, 3000 K. Street, N.W., Suite 500, Washington, DC 20007-5109 (US).</p>	<p>(81) Designated States: AE, AG, AL, AM, AT, AU, AZ, BA, BB, BG, BR, BY, CA, CH, CN, CR, CU, CZ, DE, DK, DM, DZ, EE, ES, FI, GB, GD, GE, GH, GM, HR, HU, ID, IL, IN, IS, JP, KE, KG, KP, KR, KZ, LC, LK, LR, LS, LT, LU, LV, MA, MD, MG, MK, MN, MW, MX, NO, NZ, PL, PT, RO, RU, SD, SE, SG, SI, SK, SL, TJ, TM, TR, TT, TZ, UA, UG, US, UZ, VN, YU, ZA, ZW, ARIPO patent (GH, GM, KE, LS, MW, SD, SL, SZ, TZ, UG, ZW), Eurasian patent (AM, AZ, BY, KG, KZ, MD, RU, TJ, TM), European patent (AT, BE, CH, CY, DE, DK, ES, FI, FR, GB, GR, IE, IT, LU, MC, NL, PT, SE), OAPI patent (BF, BJ, CF, CG, CI, CM, GA, GN, GW, ML, MR, NE, SN, TD, TG).</p> <p><b>Published</b> <i>With international search report.</i></p>	

(54) Title: VIBRATION DELIVERY SYSTEM AND METHOD



(57) Abstract

A comfort system for a patient includes a reference generator for generating a reference sinusoid. The reference sinusoid is preferably an 85 Hz sinusoid, that acts as a carrier signal. The reference sinusoid is frequency modulated at a particular sweep rate to produce a frequency modulated sinusoid. The frequency modulated carrier is then amplitude modulated at another sweep rate to produce an AM/FM signal. The AM/FM signal is then provided to a transducer, which provides a vibration by way of a bladder connected to a chair, bed, pillow or the like, in order to provide a soothing affect to a user sitting on the chair. The sinusoids can be created in software using signal processing techniques, or they can be created using hardware components.

*FOR THE PURPOSES OF INFORMATION ONLY*

Codes used to identify States party to the PCT on the front pages of pamphlets publishing international applications under the PCT.

AL	Albania	ES	Spain	LS	Lesotho	SI	Slovenia
AM	Armenia	FI	Finland	LT	Lithuania	SK	Slovakia
AT	Austria	FR	France	LU	Luxembourg	SN	Senegal
AU	Australia	GA	Gabon	LV	Latvia	SZ	Swaziland
AZ	Azerbaijan	GB	United Kingdom	MC	Monaco	TD	Chad
BA	Bosnia and Herzegovina	GE	Georgia	MD	Republic of Moldova	TG	Togo
BB	Barbados	GH	Ghana	MG	Madagascar	TJ	Tajikistan
BE	Belgium	GN	Guinea	MK	The former Yugoslav Republic of Macedonia	TM	Turkmenistan
BF	Burkina Faso	GR	Greece	ML	Mali	TR	Turkey
BG	Bulgaria	HU	Hungary	MN	Mongolia	TT	Trinidad and Tobago
BJ	Benin	IE	Ireland	MR	Mauritania	UA	Ukraine
BR	Brazil	IL	Israel	MW	Malawi	UG	Uganda
BY	Belarus	IS	Iceland	MX	Mexico	US	United States of America
CA	Canada	IT	Italy	NE	Niger	UZ	Uzbekistan
CF	Central African Republic	JP	Japan	NL	Netherlands	VN	Viet Nam
CG	Congo	KE	Kenya	NO	Norway	YU	Yugoslavia
CH	Switzerland	KG	Kyrgyzstan	NZ	New Zealand	ZW	Zimbabwe
CI	Côte d'Ivoire	KP	Democratic People's Republic of Korea	PL	Poland		
CM	Cameroon	KR	Republic of Korea	PT	Portugal		
CN	China	KZ	Kazakstan	RO	Romania		
CU	Cuba	LC	Saint Lucia	RU	Russian Federation		
CZ	Czech Republic	LI	Liechtenstein	SD	Sudan		
DE	Germany	LK	Sri Lanka	SE	Sweden		
DK	Denmark	LR	Liberia	SG	Singapore		
EE	Estonia						

## VIBRATION DELIVERY SYSTEM AND METHOD

### Background of the Invention

#### 5           1.    Field of the Invention

The present invention relates to a vibration delivery system and method for humans or animals. In particular, the present invention relates to a vibration delivery system and method for presenting low  
10 frequency vibration to a human or animal body directly or indirectly via a fluid, gel or solid medium.

#### 2.    Description of the Related Art

15           Humans and animals sometimes need devices that provide comfort, in order to relieve pain due to stress, old age, injuries, etc. Conventional therapies, like pharmaceuticals (such as muscle relaxants), warm baths, whirlpools, topical anesthetics, massages, vibrating devices, compresses, heat application, may be used to  
20 provide some level of comfort to a patient. With respect to vibrating devices, various types currently are available, ranging from comfort beds to back massagers and leg massagers, to name just a few. Vibrating devices provide a more effective alternative than other types of 'comfort' devices which may have potential adverse side effects,  
25 such as drowsiness from muscle relaxants. Several different types of conventional vibrating devices are discussed in detail below.

U.S. Patent No. 5,695,455, issued to Noyal Alton, Jr. and George Madsen, which is incorporated in its entirety herein by reference, discloses a hydro-acoustic massage system and method. In that system and method, a massage apparatus includes a flexible bladder filled with a fluid and having bladder displacement devices coupled to the flexible bladder. A signal source outputs first and second frequency modulated (FM) signals, which are identical in spectrum but which are propagated 180 degrees out-of-phase with respect to each other. The first FM signal is fed to one half of the bladder displacement devices, and the second FM signal is fed to the other half of the bladder displacement devices. These FM signals are controlled such that vibrational energy travels in the bladder, with a user disposed thereon, while ambient vibration of the apparatus is canceled. Such a system is shown in Figure 1, in which signals 40 and 50 correspond to the two FM signals that are out-of-phase with respect to each other.

U.S. Patent No. 5,314,403, issued to Richard Shaw, discloses an apparatus for the enhancement of the enjoyment of low frequency component of music. The apparatus is a chair with liquid-filled bladders and transducers in the seat and the back of the chair. The transducers move the liquid in the bladders, so that movement of the liquid can be felt by a user sitting in the chair. Electrical signals are filtered to pass only bass frequencies to the transducers, to thereby provide a low frequency component of music to the user by way of the movement of liquid in the chair that the user is sitting in.

U.S. Patent No. 4,507,816, issued to Gray Smith, discloses a waterbed with a sound wave system, having loudspeaker housings

positioned within the floor pedestal of the bed beneath the supporting deck for the water-filled bladder mattress. Sound waves projected from the loudspeakers cause waves to form in the water within the mattress, so that a person reclining on the mattress will feel as well as  
5 hear the sound and music passing through the mattress.

U.S. Patent No. 5,086,755, issued to Helmut Scmid-Eilber, discloses a therapeutic chaise lounge that includes three support sections hinged together for comfortably supporting a patient. The support sections have openings formed therein with electroacoustic  
10 transducers movably disposed below the openings. The transducers radiate upwardly through the openings at the lower back, the chest and the head/neck areas of a patient resting on the chaise lounge with an enhanced signal of a frequency corresponding to the rhythm frequency of certain music to which the patient's body is exposed, in which the  
15 rhythm frequency is in the non-audible range. This provides enhanced relaxation of the patient.

While each of the above-mentioned comfort/relaxation systems provide a level of comfort to a user, they operate on frequencies that typically correspond to music or the like, and provide those  
20 frequencies, with minimal processing, to the user. The Alton and Madsen reference does not utilize a frequency that corresponds to music, but rather provides two FM signals that effectively operate together to cancel out an unwanted vibration.

As such, a system or method for providing better comfort and/or  
25 relaxation for a user is desired.

### Summary of the Invention

It is an object of the present invention to provide a vibration delivery system or method that provides comfort to a user.

5 It is a further object of the present invention to provide a vibration delivery system or method that utilizes low frequency vibration that is swept across a range of frequencies, with that low frequency vibration being provided to a user.

The above-mentioned objects and other advantages may be  
10 obtained by a method for providing vibrations to a user. The method includes a step of providing a sinusoidal signal at a fixed frequency value. The method also includes a step of frequency modulating (FM) the sinusoidal signal in a range between a first frequency value less than the fixed frequency value, and a second frequency value that is  
15 greater than the fixed frequency value. The method further includes a step of amplitude modulating (AM) the frequency modulated sinusoidal signal to provide an output signal, the output signal being amplitude modulated being performed from a first amplitude level to a second amplitude level, and at a rate that is swept between a third  
20 frequency value and a fourth frequency value, where the fourth frequency value is greater than the third frequency value, and is less than the first frequency value. The method still further includes a step of providing vibrations to the user in accordance with the output signal. The vibrations are preferably applied to at least one bladder  
25 filled with liquid or gel, with that bladder being disposed within, for example, a bed mattress, thereby providing the vibrations to the user as the user rests on the bed mattress.

Preferably, the frequency modulating and the amplitude modulating are both swept between frequencies in the respective ranges, with the sweep rate being different for the FM and the AM.

The above-mentioned objects and other advantages may be  
5 obtained by an apparatus for providing vibrations to a user. The  
apparatus includes a signal generator that is configured to provide a  
sinusoidal signal at a fixed frequency value. The apparatus also  
includes a frequency modulator that is configured to receive the  
sinusoidal signal and to frequency modulate the sinusoidal signal in a  
10 range between a first frequency value less than the fixed frequency  
value, and a second frequency value that is greater than the fixed  
frequency value. The apparatus further includes an amplitude  
modulator configured to receive the frequency modulated sinusoidal  
signal, and to amplitude modulate the frequency modulated sinusoidal  
15 signal to provide an output signal, where the output signal is amplitude  
modulated between a first amplitude level and a second amplitude  
level, and where the amplitude modulation is performed at a rate that  
is swept between a third frequency value and a fourth frequency  
value, where the fourth frequency value is greater than the third  
20 frequency value, and is less than the first frequency value. The  
apparatus still further includes a vibrator configured to receive the  
output signal and to provide vibrations to a user in accordance with the  
output signal. The vibrations are preferably applied to at least one  
bladder filled with liquid or gel, with that bladder being disposed  
25 within a bed mattress, for thereby providing the vibrations to the user  
as the user rests on the bed mattress.

### Brief Description of the Drawings

The above-mentioned object and advantages of the invention will  
5 become more fully apparent from the following detailed description  
when read in conjunction with the accompanying drawings, with like  
reference numerals indicating corresponding parts throughout, and  
wherein:

Figure 1 shows a conventional hydro-acoustic massage unit;

10 Figure 2a shows a typical analog signal;

Figure 2b shows a sampled version of the analog signal of Figure  
2a;

Figure 3 is a graph of a digitized sinusoidal waveform;

15 Figure 4 is a graph of a digitized sinusoidal waveform that has  
been scaled by a factor of two;

Figure 5 shows a reference sinusoidal signal that may be utilized  
in forming a carrier wave according to a first embodiment of the  
invention;

20 Figure 6 shows a sinusoidal reference waveform and another  
modulating waveform that is used to frequency modulate the reference  
waveform, according to the first embodiment of the invention;

Figure 7 shows the results of the frequency modulation of the  
reference waveform, in which a frequency modulated waveform is  
formed, according to the first embodiment of the invention;

25 Figure 8 shows the frequency modulated waveform and another  
sinusoidal waveform that is used to amplitude modulate the frequency



modulated waveform, according to the first embodiment of the invention;

Figure 9 shows the result of the amplitude modulation of the frequency modulated waveform, according to the first embodiment of the invention;

Figure 10 shows a first alternative configuration of the present invention using hardware components;

Figure 11 shows a second alternative configuration of the present invention using hardware components; and

Figures 12a - 12c respectively show levels of energy, displacement, and acceleration versus frequency that are provided by transducers that may be utilized in the present invention.

#### Detailed Description of the Preferred Embodiments

15

The present invention will be described in detail below with reference to the drawings. The present invention utilizes signal processing techniques for providing a low frequency vibration to a user, where that low frequency vibration is preferably provided to a user on a chair, bed, a table, a cushion, a pad or other device in which the user can rest thereon. These vibrations provide an analgesic effect to the user, which is very desirable to persons suffering from injuries, old age, stress, fatigue, or the like. Also, the present invention can be utilized to provide comfort to animals as well as humans.

25 Before a detailed description of the present invention is provided, a brief description of waveforms and signal processing will be provided in order to provide a better understanding of the present

invention. Waveforms are in a very general sense a computer approximation of a natural occurring audio, vibratory, or ultrasonic event. In nature, these periodic events are actually vibratory patterns displacing through a medium such as air or water. Through air, a  
5 vibration in the range of approximately 20 Hz to 20 kHz can be detected by the average human ear, with that vibration being known as sound. However, there are other events either lower or higher than the audible frequency range. Periodic events lower than the range of human hearing are known as infrasound, and periodic events higher  
10 than the range of human hearing are known as ultrasound. Digital audio presents some real benefits in the development of signals operating in the infrasound range, the audible range and the ultrasound range.

In order to generate waveforms of varying frequencies and  
15 amplitudes, oscillators and function generators are typically used. While these provide immediate feedback during experimentation, they are limited in the types of waveforms they can produce. A computer can also generate waveforms through software programs, and these are more accurate, flexible and less prone to drift than their stand-  
20 alone hardware components. For this reason, signals generated by software often are preferred for implementation of the present invention. However, hardware components may be utilized as an alternative embodiment.

The present invention provides a waveform pattern that is used to  
25 generate a so-called analgesic signal for pain relief and massage applications. This signal is a compound frequency modulated and amplitude modulated signal, with a corresponding sweep bandwidth

that is provided for both types of modulation at the same time. Generated on the computer, the information is then transferred to an output device, such as a standard audio compact disk (CD), which can be played back on any standard consumer CD player. The output of  
5 the CD player is provided to a vibratory element, such as a transducer. Other forms of storage media besides a CD, including magnetic, optical, magneto-optical, and stylus-based (i.e., records), may be employed as alternative storage devices. Using a CD, an AM/FM waveform can be stored therein to provide up to 30 minutes  
10 of comfortable vibration to a patient. Once the CD has been played, it can be replayed again and again to provide the desired amount of treatment time to the patient.

The following discussion relates to how the computer produces sound signals. This discussion has been derived from a product  
15 brochure of Tucker-Davis Technologies, of 4637 N.W. 6<sup>th</sup> Street, Gainesville, Florida. Sound corresponds to changing fluctuations of energy in air. Sound can be represented by use of a computer. However, a computer deals only with numbers (e.g., bits that are set to either 0 or 1). Computers cannot understand or hear sound as  
20 humans and animals do. In order for a computer to produce sound, it must translate that sound into numbers. This is accomplished an analog-to-digital converter (ADC). The ADC samples an analog voltage periodically, and represents each sampled voltage at a particular time sample with a number. For professional sound, the  
25 sampling time period is approximately 0.0133 seconds, or 13.3 milliseconds. In order to construct a contiguous wave, the ADC must therefore sample at 44,100 times a second, where each sample is

represented inside the computer by a number. If the resolution of the number is 16 bits, then that yields  $2^{16} = 65,535$  possible values to represent the waveform.

Figure 2a shows an analog signal 210, such as a sound signal,  
5 and Figure 2b shows the analog signal being sampled periodically, to provide a sampled signal 220 that matches the analog signal at the sampling time instants. As seen from Figure 2b, multiple samples when arranged side by side in a computer memory, form a digital representation of the original sound wave. To play the sound back,  
10 the computer outputs these values to a digital-to-analog converter (DAC). The DAC performs the opposite task with respect to the ADC, and translates the numbers to individual voltage levels at the same playback sampling speed as the original sample. The voltages can then be fed through an amplifier to a speaker, to produce the  
15 sound. Of course, the computer does not always have to sample an original sound, and it can just as easily arrange a series of numbers together to form patterns, which can then be fed to the DAC. The sound which is produced in that case is totally synthetic, since it has no natural origin. Through mathematical functions, arrays of numbers  
20 can be built and manipulated before being converted to sound, and it is in this manner that the various waveforms utilized in the present invention are preferably produced.

An example will now be provided as to how a simple sine wave is created inside a computer's memory. First, an array of memory  
25 locations is allocated, with this array holding data corresponding to one cycle of the sine wave. For example, assume that an array of 256 memory locations, although an array of any size could be built to

create a sine wave. Next, a sine wave pattern is created in the array. To do this, the following mathematical formula can be utilized:

$$\text{Loc}_i - \sin(2*\Pi*i)$$

where Loc is the memory location indexed by the pointer i.

- 5 Repeating this equation 256 times with i incrementing from 0 to 255 will yield a sine wave pattern in the memory array. Figure 3 is a graph of the above mathematical function repeated 10 times.

As is evident from Figure 3, the numbers on the y axis represent the voltage levels and run from 1 to -1. If the y axis numbers were to  
10 be scaled by 2, by using the following equation:

$$\text{Loc}_i - \sin(2*\Pi*i)$$

then the waveform would look like the one shown in Figure 4.

Once the array is created, the computer can duplicate it many times to create a continuous waveform, and can send the data to the  
15 DAC to be converted into sound, with that sound sounding like a pure tone to the human ear. Inside the array, the computer can be programmed to scale all of the numbers or some of the numbers, which will affect the level of the signal and thus the amplitude of the waveform. If the numbers are scaled using the same formula as was  
20 used to create the sine wave, then an amplitude modulated waveform will result. In the present invention, the amplitude modulation is performed at a rate that is less than the rate (which corresponds to the inverse of the period of the waveform) of the sine wave that is being subject to the AM. If the numbers corresponding to the sine wave are  
25 altered as to their location in time, by the same token a frequency modulated waveform will result.

The present invention provides a waveform which includes a carrier wave (first sinusoid) amplitude modulated by a second sinusoid and then frequency modulated by a third sinusoid, with each sinusoid being represented as a mathematical formula that is created in software and run on a computer in order to provide each sinusoid. In an alternative configuration, each of the sinusoids are generated by hardware components.

The present invention according to the first embodiment of the invention can be broken down to the following steps.

10 In a first step, a first sinusoidal waveform is created in a computer memory by software.

In a second step, a frequency modulated waveform is created in a computer memory, by altering the samples of the first sinusoidal waveform created in the first step with respect to their individual positions in time. This altering is provided by way of a second sinusoidal waveform.

In a third step, the scale of the individual samples of the second sinusoidal waveform are changed using a third sinusoidal waveform, in order to amplitude modulate the second sinusoidal waveform.

20 In a fourth step, the samples are looped to form a continuous changing waveform, which is then written to a file on the computer's hard drive or other storage device accessible by the computer.

In a fifth step, the computer file is transferred to a digital storage and playback device, such as a compact disk (CD), by using, for example, a CD recorder communicatively coupled to the computer. The entire file may be looped while recording to the CD to create very long CD tracks, such as ones as long as 1 hour or perhaps more. This

is done so that extensive amounts of data does not have to be stored on the computer's hard drive or the like, which would consume a lot of memory space (e.g., 1 minute of signal can take up to 5 million bytes of hard disk space).

5       The above description is for generating a waveform by a computer, and then transferring that waveform to a CD or other type of device that can play back the waveform. This results in a static signal which plays for a certain time on the CD, with that signal of course changing according to the FM and AM applied to it. In an  
10 alternative configuration, a plurality of separate tracks can be created, each with a different type of signal according to a desired effect it will have on a user.

      Given the above discussion of waveforms in general and the present invention, more details are provided hereinbelow. The present  
15 invention utilizes waveforms created preferably in software, but these waveforms can alternatively be created by hardware components, such as oscillators, sweeping circuits, frequency modulators, amplitude modulators, and the like. The waveforms, if created in software, are transferred to a storage medium, such as a CD, for playback onto a  
20 device, such as a CD player. The CD player is attached through power amplifiers to selected transducers which are preferably mounted to various locations on a platform. The platform may be a bed, a massage table, a gurney, a chair, a pad, or the like. Possible applications of the present invention may including vibrating limbs to  
25 alleviate pain, whole body massage for relaxation, and automotive massage and pain relief during extended trips in a vehicle.

A sinusoidal reference waveform (e.g., sine wave or cosine wave) is generated at a fixed frequency, which is set to 85 Hz in the first embodiment. The sinusoidal reference waveform may be created by a computer running a program, as explained above, or it may be  
5 created by hardware, such as an oscillator providing an 85 Hz sinusoidal waveform. Figure 5 shows an 85 Hz sine wave, designed by label 510, that has an amplitude that varies between a maximum of +1 and a minimum of -1, where that amplitude can be set to any particular value based on the degree of vibration to be provided to a  
10 user. The sinusoidal reference waveform 510 acts as a carrier wave, to be explained in greater detail below. The sinusoidal reference waveform 510 is swept from a minimum frequency and a maximum frequency, where the minimum frequency is preferably set to 60 Hz, and where the maximum frequency is preferably set to 110 Hz. This  
15 results in a swept carrier signal, where the sweeping is performed by modulating the sinusoidal reference waveform by another waveform at a particular sweep rate to obtain a frequency modulated waveform. The range of sweeping is set at its low end to 25 Hz below the reference frequency of 85 Hz, and at its high end to 25 Hz above the  
20 reference frequency of 85 Hz. In other words, the frequency modulated waveform sweeps in the following manner: 85 Hz up to 110 Hz, then back down to 60 Hz, then back up to 110 Hz, etc.

Figure 6 shows the sinusoidal reference waveform 510 and another modulating waveform 610 that is used to frequency modulate  
25 the sinusoidal reference waveform 510. The result of this frequency modulating of the sinusoidal reference waveform is a frequency modulated waveform 710, as shown in Figure 7. The frequency



modulated waveform varies from a minimum frequency of 60 Hz to a maximum frequency of 110 Hz, and varies its frequency in a linear manner periodically to provide a swept carrier signal that corresponds to the frequency modulated waveform 710.

5 In the first embodiment, the modulating waveform 610 is created in software, and is represented in amplitude by one of  $2^{16}$  values (e.g., 16 bit representation of signal magnitude for each sample of the waveform 610). Typically, the maximum deviation frequency is set to a ratio of 1 Hz to 1 amplitude level of the modulating waveform.

10 However, in the first embodiment, given the deviation frequency range of from 60 Hz to 110 Hz about a reference frequency of 85 Hz, the deviation frequency may be set to a ratio of  $32767 / 25 \approx 131$ , where a 131-binary value change of the modulating waveform 610 result in a 1 Hz frequency deviation of the FM waveform 710. That

15 131-binary value change can be set to represent a 1 volt change in the frequency modulating signal, a 10 volt change in the frequency modulating signal, or to any other amplitude level change, as desired. Of course, other ratios may be envisioned based on the frequency deviation ratio desired, as well as the number of amplitude values

20 allowed for the modulating waveform 610. For example, if the binary value representative of the modulating waveform 610 is at a value equal to  $0000000000000000_{bin} = 0$  (representing a '0' amplitude value for the modulating waveform 610) in decimal notation, then that value would have to change to  $0000000010000011_{bin} = 131$  in decimal

25 notation (representing a small positive amplitude value for the modulating waveform 610) to cause a 1 Hz frequency change in the frequency modulated waveform 710 (e.g., from 85 Hz to 86 Hz) A

change in the modulating waveform by another 131 amplitude steps would cause another 1 Hz frequency change in the same direction in the frequency modulated waveform (e.g., from 86 Hz to 87 Hz).

The modulating waveform 610 can be set to any particular low  
5 frequency value, depending upon the desired effect. The modulating waveform 610 is multiplied with the sinusoidal reference waveform 510, to thereby provide the frequency modulated waveform 710, in a manner known to those skilled in the art of signal processing. The sweep rate of the frequency modulated waveform 710 is preferably  
10 within a range of from 0.03 Hz to 1 Hz. Thus, at the 1 Hz sweep rate, the swept carrier signal 710 sweeps from a low of 60 Hz to a high of 110 Hz and back to 60 Hz in 1 second, and at the 0.03 Hz sweep rate, the swept carrier signal 710 sweeps from a low of 60 Hz to a high of 110 Hz and back to 60 Hz in  $1/0.03 = 33$  seconds. The  
15 sweep rate is adjusted to suit an individual patient's needs, based on type of stimulus desired, by trial-and-error or other suitable methods.

The swept carrier signal 710 is then amplitude modulated by a low frequency sinusoidal waveform 810, to thereby control the envelope of the swept carrier signal 710 in a predetermined manner.  
20 The amplitude modulating (AM) is provided to the swept carrier signal 710 to change its amplitude from full volume (its maximum level) to an arbitrary volume level. The arbitrary volume level can be set to any value below full volume, such as 0 level, 20% of full volume, 35% of full volume, etc., based on the desired effect on a user. By  
25 this manner, an FM waveform, that being the swept carrier signal 710, is amplitude modulated by a low frequency waveform 810, in order to create an output signal that can be provided to a patient. The

way of providing such an output signal to the patient can be done in a manner known to those skilled in the art, such as providing the output signal to transducers that stimulate bladders filled with fluid, with those bladders being disposed on a bed, chair or the like, in which the patient is resting on.

Figure 8 shows the swept carrier signal 710 and another, low frequency sinusoidal signal 810 that is used to amplitude modulate the swept carrier signal so as to create the output signal which is an AM/FM signal.

Figure 9 shows the amplitude modulated swept carrier signal 910, which corresponds to the output signal mentioned above. In Figure 8, the amplitude is varied from a maximum level "A" to a minimum level "0", but other minimum levels may be utilized to suit a patient's needs and desires. The amplitude modulation rate in the first embodiment has a AM sweep rate of 0.066 Hz or once every 15 seconds, as a preferred sweep rate. Thus, in 15 seconds, the AM goes from a low of 0 Hz up to a high of 4 Hz, and back to a low of 0 Hz. The upper range of the AM may be set to as high as 59 Hz (from 4 Hz value set in the first embodiment) based on a particular patient's needs, and the AM sweep rate may be varied based on the particular patient's needs as well. In one configuration, the AM rate starts at 2 Hz, is swept up to a value of 4 Hz, is then swept down to a value of 0 Hz, is then swept up to a value of 4 Hz, etc. (e.g., 2 Hz, 3 Hz, 4 Hz, 3 Hz, 2 Hz, 1 Hz, 0 Hz, 1 Hz, 2 Hz, 3 Hz, 4 Hz, 3 Hz, . . .). If the AM rate was from 0 to 10 Hz, then the AM rate would start at 2 Hz, would then be swept up to 10 Hz, would then be swept down to 0 Hz, would then be swept up to 10 Hz, and so on.

By providing a sliding amplitude modulating frequency and a sliding carrier, the patient is provided with a soothing signal that is used to vibrate a medium, such as a fluid, gel, or solid medium disposed on a chair, bed or the like in which the patient is resting.

5 The low frequency sinusoidal signal 810 that is used to provide amplitude modulation of the swept carrier signal 710 can be set to sweep the frequencies that resonate bodily organs. Those frequencies and the respective bodily organs are: eyes, 20-25 Hz; feet, 16-31 Hz; legs, 4-8 Hz; lower back, 4-14 Hz, abdomen, 4-12 Hz; chest, 6-12

10 Hz, and shoulders, 2-6 Hz. Information related to the frequencies that resonate bodily organs may be found from various sources, such as: 1) B.K.N. Rao et al., Subjective Effects of Vibration, published in W. Tempest ed., Infrasound and Low Frequency Vibration, Academic Press, London, pages 187-234, 1976; 2) D.E. Wasserman, Human

15 Aspects of Occupational Vibration, published by Elsevier, New York, 1987. The carrier signal is swept over frequencies that have been found to have an analgesic effect, such as relief of itching and/or pain reduction. Information related to the frequencies that provide an analgesic effect to a user may be found in various sources, such as: 1)

20 R. Kakigi et al., Mechanism of Pain Relief by Vibration and Movement, published in Neurol. Neurosurg. Psychiatry, Vol. 55, pages 282-286, 1992; 2) T. Lumdeberg et al., Pain Alleviation by Vibratory Stimulation, published in Pain Journal, Vol. 20, pages 25-44, 1984; 3) R. Melzack et al., Itch and Vibration, published in

25 Science Magazine, Vol. 147, pages 1047-1098, 1965; and 4) M. Zoppi et al., Pain Threshold Changers By Skin Vibratory Stimulation in Healthy Subjects, published in Acta. Physiol. Scand., Vol. 143,

pages 439-444, 1991. The information in the above-referenced articles are incorporated in their entirety herein by reference. The combination of an AM/FM waveform that is set to sweep within particular frequencies in both frequency and amplitude is provided in  
5 the present invention to provide a signal that can cause corresponding vibrations that are felt by a patient. Although not bound by any particular theory, it has been postulated that the FM sweep rate causes a release of endorphins for patients, which provides a measure of relief from pain, stiffness, and the like.

10 Referring now to Figure 1, which shows a comfort bed according to a conventional vibrating device, the present invention may utilize such a comfort bed as shown in Figure 1, but with a different waveform applied to the comfort bed. The present invention utilizes transducers to provide the vibration to the bed, with such  
15 transducers being, by way of example and not by way of limitation, Aura bass shakers, which are relatively inexpensive. This and other types of transducers require about 100 watts rms. The frequency response of the shaker is preferably in the range of from 26 to 110 Hz, in order to provide the vibrational carrier frequencies according to  
20 the present invention. The impedance of the Aura bass shaker is about 4 ohms, and its size ranges from 6 to 12 inches in diameter and 3 inches in depth, depending upon the particular model chosen. These values are exemplary, and are not meant to limit the size and other attributes of transducers that may be utilized with the present  
25 invention.

In the present invention, a plurality of transducers are placed on the bed, to provide vibrations to different parts of the patient at the

same time. For example, one transducer may be placed on the underside of the bed nearby where the upper thorax of the patient would be located (for an average-sized patient), and another transducer may be placed on the underside of the bed where the patient's pelvis and thighs would be located.

Based on experiments performed by the inventors, in one case without body loading on a comfort device, the displacement at 80 Hz was 0.0000054 meters rms, and in another case with body loading, the displacement was 0.0000234 meters rms. These displacement levels were with an average of 4 volts delivered to the transducers (range varies with frequency, 2 to 5.5 volts). Figure 12a shows energy versus frequency, Figure 12b shows displacement versus frequency, and Figure 12c shows acceleration versus frequency, for a transducer that may be utilized in the embodiments of the invention discussed above. These values are shown for both a loaded state (e.g., person on apparatus) and an unloaded state (e.g., no one on apparatus), where the loaded state corresponds to the lower curve in each of Figures 12a - 12c. The values provided in Figures 12a - 12c are minimum levels, and can be increased another 20 dB or more, based on a particular user's desired comfort range. The present invention typically operates about two orders of magnitude below any threshold that might rise to a safety concern, based on current standards. The displacement values shown in Figure 12b correspond to movement of the comfort apparatus (e.g., bed or chair) due to vibrations in accordance with the present invention, and the acceleration values in Figure 12c correspond to acceleration of the comfort apparatus due to vibrations in accordance with the present invention.

While the implementation of the present invention has been described above with respect to a bed, other types of comfort devices, such as a chair seat/back, a pillow arrangement, or other types of arrangements, may be utilized. In particular, the present invention is applicable to an apparatus with a layer of foam or gel or the like, and with shakers (e.g., transducers) disposed under the layer of foam. The patient would be resting on the layer of foam, on the side opposite to where the shakers are disposed. In an alternative configuration, the transducers may be embedded in the vibrating layer itself (e.g., in a packet of gel).

In a second embodiment, recorded air bubble sounds are used together with the vibrations provided in the first embodiment, to provide an additional soothing effect for the patient. The air bubble sounds provide a 'dry' whirlpool sensation for the patient. The air bubble sounds can be digitized and stored in a computer memory, and then downloaded to a CD to be played by a CD player, as one example.

While preferred embodiments have been described herein, modification of the described embodiments may become apparent to those of ordinary skill in the art, following the teachings of the invention, without departing from the spirit and scope of the invention as set forth in the appended claims. For example, Figure 10 shows an alternative configuration, in which a local oscillator 1010 provides a first sinusoid 1020 that corresponds to the reference sinusoid (100 Hz sinusoid). Such oscillators are well known and are readily obtainable from various electronics manufacturers. The first sinusoid 1020 is frequency modulated by a frequency modulator 1030, at a sweep rate

based on a first control signal 1040 provided to the frequency modulator 1030 by a control unit 1090. The frequency modulated carrier 1050 output from the frequency modulator 1030 is then amplitude modulated by an amplitude modulator 1060, at a sweep rate  
5 based on a second control signal 1070 provided to the amplitude modulator 1060 by the control unit 1090. The AM/FM output signal of the amplitude modulator 1060 is provided to transducers (not shown), to apply an analgesic vibration to a patient by way of a bed, chair, mattress, or the like. In Figure 10, the control unit 1090 may  
10 be provided by way of a microprocessor or the like. Alternatively, the sweep rates may be preset in hardware, in which case the control unit would not be required. In the first embodiment, the sweep rate of the AM is less than the sweep rate of the FM. For example, with a 0.033 Hz FM sweep rate = one FM sweep for every 30 seconds, an  
15 AM sweep rate of 0.016 = one AM sweep for every 15 seconds is preferably used.

Figure 11 shows a second alternate configuration of the present invention in hardware. A first function generator/oscillator 1110 is set to a frequency of 0.066 Hz and an amplitude level of two. The output  
20 1115 of the first function generator/oscillator 1110, which is a signal used to provide the FM sweep rate, is provided to the FM input 1120 of a second function generator/oscillator 1125. The second function generator/oscillator 1125 is set to a frequency of  $2 + \text{FM Hz}$ , with an amplitude level of one. The output 1130 of the second function  
25 generator/oscillator 1125 is provided to an AM input of a third function generator/oscillator 1135. A fourth function generator/oscillator 1145 is set to a frequency of 0.033 Hz and an



amplitude level of 25. The output 1150 of the fourth generator/oscillator 1145, which is a signal used to provide the AM sweep rate, is provided to the FM input 1155 of the third function generator/oscillator 1135. The output 1160 of the third function generator/oscillator 1135 is an AM/FM waveform, which is provided to transducers and/or amplifiers (not shown), so as to provide an effective vibration to a patient by way of a bed, a chair/seat, a pillow, or other type of device that a patient may be resting against. The hardware construction of Figure 11 presupposes that an amplitude level of one will cause a deviation from carrier of one Hz +/- on an FM input, and will cause zero (0) to full output on an AM input, and all waves output by the hardware construction of Figure 11 are pure sinusoidal waveforms. Of course, other implementations are possible while remaining within the scope of the invention are described herein.

Furthermore, while the first embodiment was described with reference to an 85 Hz reference sinusoid that was frequency modulated to provide an FM range of from 60 Hz to 110 Hz, other reference sinusoids that are not symmetric with respect to the lower and upper FM frequencies may be used. For example, a 100 Hz reference sinusoid may be used to provide an FM signal from anywhere between 60 Hz and 110 Hz, where wave clipping is used to limit the sweep to the desired FM range. This approach may result in the FM waveform spending more time at the lower and upper ends of the FM range during a particular sweep, however. Also, the FM sweep range may be varied from as low as 26 Hz to up to 110 Hz. Values greater than 110 Hz result in audible noiselike sounds that are

discernable by the patient, and are undesirable. Furthermore, the AM sweep range can be anywhere from 0.1 Hz up to 26 Hz.

The choice of an AM sweep range and an FM sweep range for a particular patient is based on the individualized needs of a particular patient, as well as that patient's body structure (e.g., height and weight), and the present invention allows for individualized control to provide a desired AM/FM waveform for any particular patient. The AM and the FM sweeps are semi-independent in that they both start at zero amplitude and zero phase. The time of sweep and the exact range (some fraction of the AM and the FM range) is chosen to produce a soothing vibration for the patient.

The present invention may also be used as a retrofit to a standard bed or chair, and for such beds as a waterbed or the like, there is no need to provide a fluid layer or foam layer, since one is already there. In such instances, transducers may be affixed to the waterbed to provide vibrations to the patient that are felt by way of vibrations in the water within the bed.

Also, while the present invention has been described with respect to providing a single AM/FM waveform, other implementations are possible in that a different AM/FM waveform may be provided to different transducers located at different areas on a layer of foam or liquid or gel. For example, a first AM/FM waveform may be provided on a first channel to a transducer disposed nearby where a patient's head would be located, a second AM/FM waveform may be provided on a second channel to a transducer nearby where a patient's upper back is located, a third AM/FM waveform may be provided on a third channel to a transducer nearby where a patient's lower back is

located, and so on. Based on the different vibrational frequencies of various body organs, as discussed previously, each AM/FM waveform may be fine-tuned for the respective body part that it is nearest to.

The providing of different AM/FM waveforms on separate  
5 channels is readily achievable by today's powerful personal computers, whereby an eight channel system, or more, can be implemented. For example, currently-available DVD systems have the capability for six-channel sound, and can be utilized to store AM/FM waveforms from a personal computer, and to provide the  
10 separate waveforms at the same time to the patient, via different transducers.

With this multiple-channel configuration, a patient may be provided with a first waveform for the legs, for example, and a second waveform for the back, for example. One CD (or one track of a CD)  
15 may be used to provide the first waveform to a transducer (or transducers) on the apparatus nearby one's legs, and a second CD (or another track of the same CD) may be used to provide the second waveform to a transducer (or transducers) on the apparatus nearby one's back, for example. The patient may be provided with a control,  
20 such as a rotatable button disposed on the apparatus or away from the apparatus but communicatively coupled to the apparatus (e.g., via wireless communications such by an infrared signal sent from a remote control unit to the apparatus), for allowing patient-controlled changes to either or both of the AM and the FM sweep rates for each  
25 particular output AM/FM waveform, in order that a desired set of signals (that do not interfere with each other) may be provided at the same time to the patient. A set of CDs in a CD player may be utilized

to play certain CDs based on a particular setting of the button by the patient.

In yet another alternative configuration, a sensor or sensors may be provided for each vibrating element, such as for each gel pack or  
5 foam pack to be vibrated, whereby the each sensor provides a feedback signal to the apparatus. The feedback signal is used to sense the body's acoustical responses to a particular AM/FM waveform, and from the feedback signal, a CD (from a set of CDs) or a particular track of one CD is chosen to achieve a desired analgesic effect.

What Is Claimed Is:

1. A method for providing vibrations to a user, the method comprising:  
providing a sinusoidal signal at a fixed frequency value;  
5 frequency modulating (FM) the sinusoidal signal in a range between a first  
frequency value less than the fixed frequency value, and a second frequency value  
that is greater than the fixed frequency value;  
amplitude modulating (AM) the frequency modulated sinusoidal signal to  
provide an output signal, the output signal being amplitude modulated being  
10 performed from a first amplitude level to a second amplitude level, and at a rate  
that is swept between a third frequency value and a fourth frequency value,  
wherein the fourth frequency value is greater than the third frequency value, and is  
less than the first frequency value; and  
providing vibrations to the user in accordance with the output signal.  
15
2. The method according to claim 1, wherein the vibrations are applied to at  
least one bladder filled with liquid or gel, wherein the bladder is disposed within  
one of a bed mattress, a chair, and a pad.
- 20 3. The method according to claim 1, wherein the frequency modulating and  
the amplitude modulating are both swept between frequencies in the respective  
ranges, with the sweep rate being different for the FM and the AM.
4. The method according to claim 1, wherein the frequency modulating is  
25 swept within a range of from 26 Hz to 110 Hz.

5. The method according to claim 1, wherein the amplitude modulating is swept within a range of from 0.1 Hz and 26 Hz.

6. An apparatus for providing vibrations to a user, comprising:

5 a signal generator that is configured to provide a sinusoidal signal at a fixed frequency value;

a frequency modulator that is configured to receive the sinusoidal signal and to frequency modulate the sinusoidal signal in a range between a first frequency value less than the fixed frequency value, and a second frequency value that is  
10 greater than the fixed frequency value; and

an amplitude modulator configured to receive the frequency modulated sinusoidal signal, and to amplitude modulate the frequency modulated sinusoidal signal to provide an output signal, wherein the output signal is amplitude modulated between a first amplitude level and a second amplitude level, and wherein the  
15 amplitude modulation is performed at a rate that is swept between a third frequency value and a fourth frequency value, wherein the fourth frequency value is greater than the third frequency value, and is less than the first frequency value; and

a vibrator configured to receive the output signal and to provide vibrations to a user in accordance with the output signal.

20

7. The apparatus according to claim 6, wherein the vibrator includes at least one bladder filled with liquid or gel.

8. The apparatus according to claim 7, wherein the at least one bladder is  
25 disposed in one of a bed mattress, a chair, and a pad.

9. The apparatus according to claim 6, wherein the frequency modulation is swept within a range of from 26 Hz to 110 Hz.

10. The apparatus according to claim 6, wherein the amplitude modulation is  
5 swept within a range of from 0.1 Hz and 26 Hz.

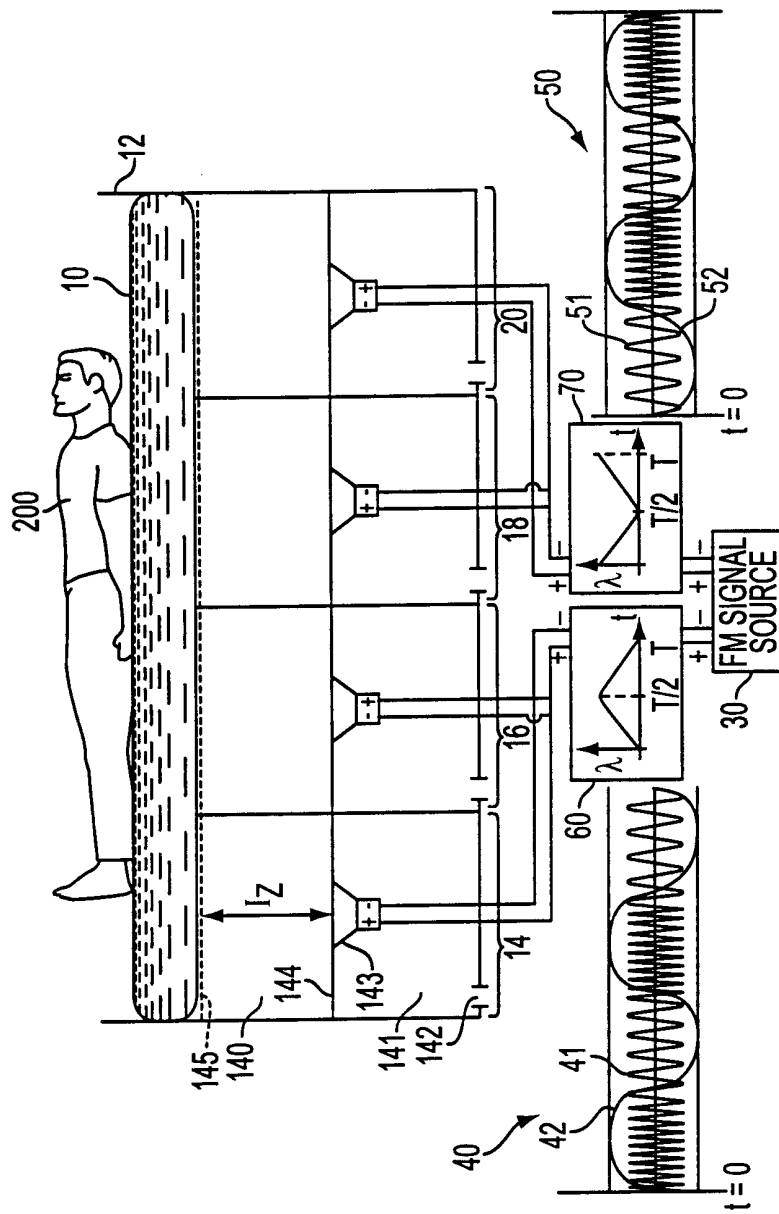

FIG. 1  
PRIOR ART



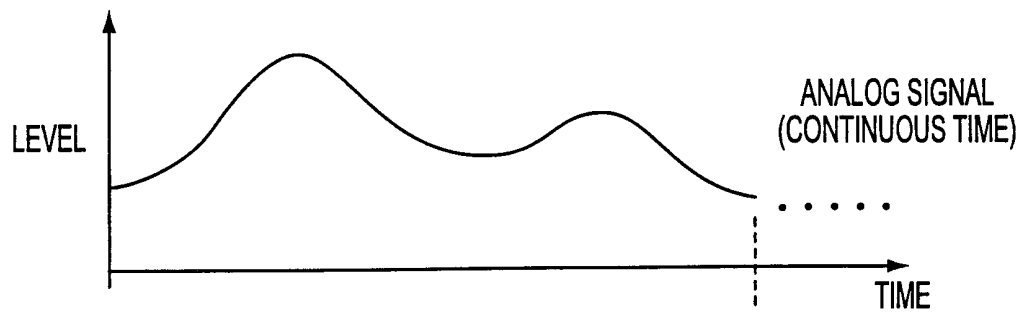

FIG. 2A

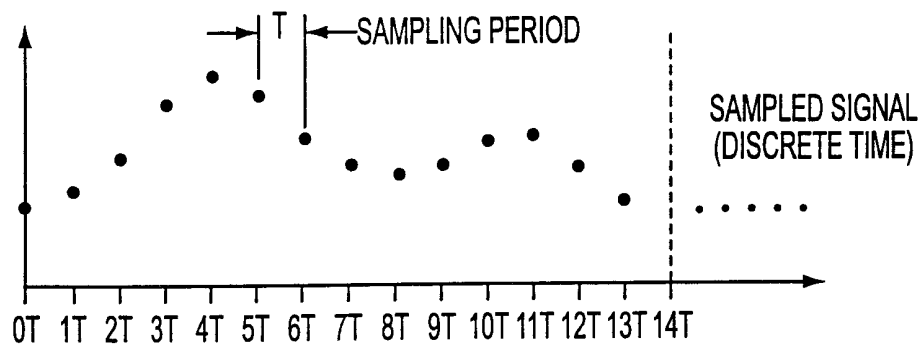

FIG. 2B

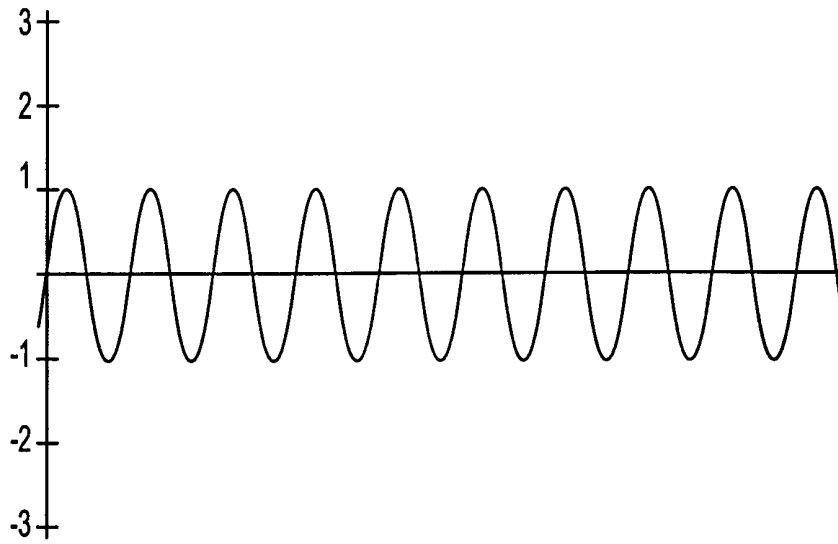

FIG. 3

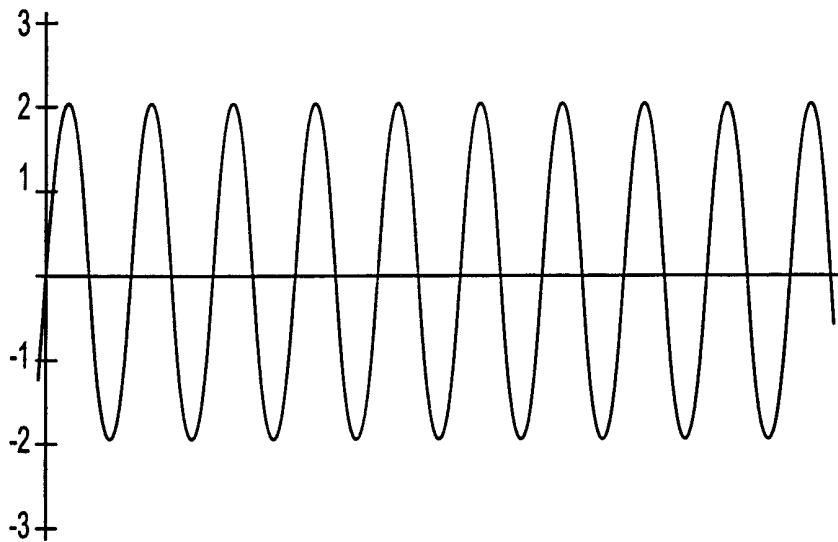

FIG. 4

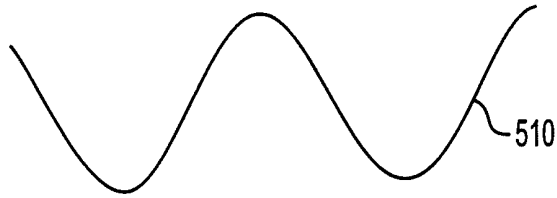

FIG. 5

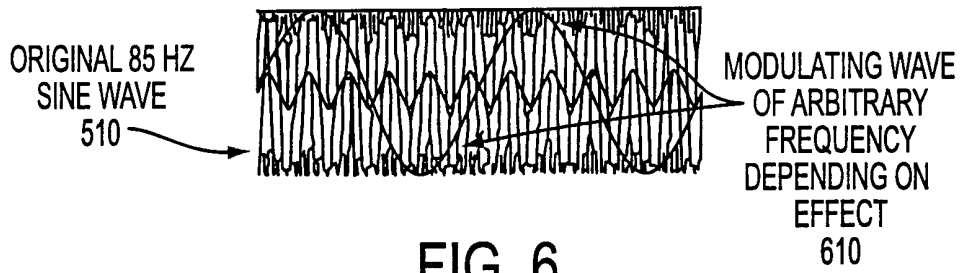

FIG. 6

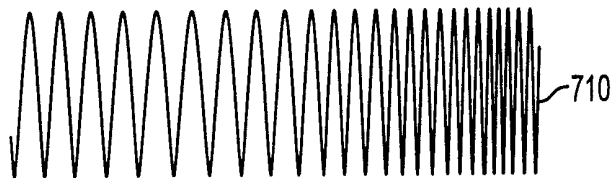

FIG. 7

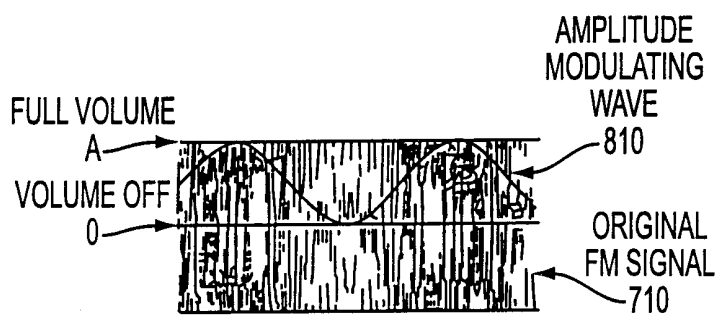

FIG. 8

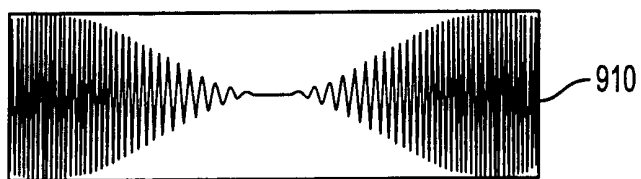

FIG. 9

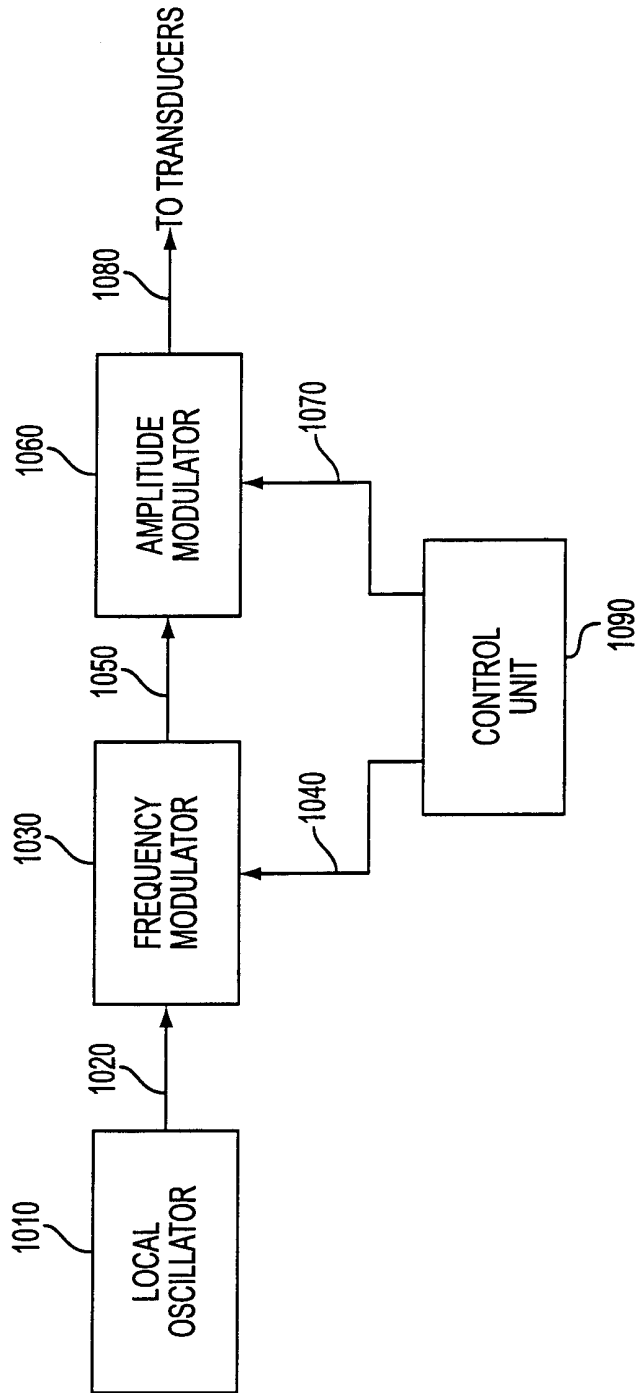

FIG. 10

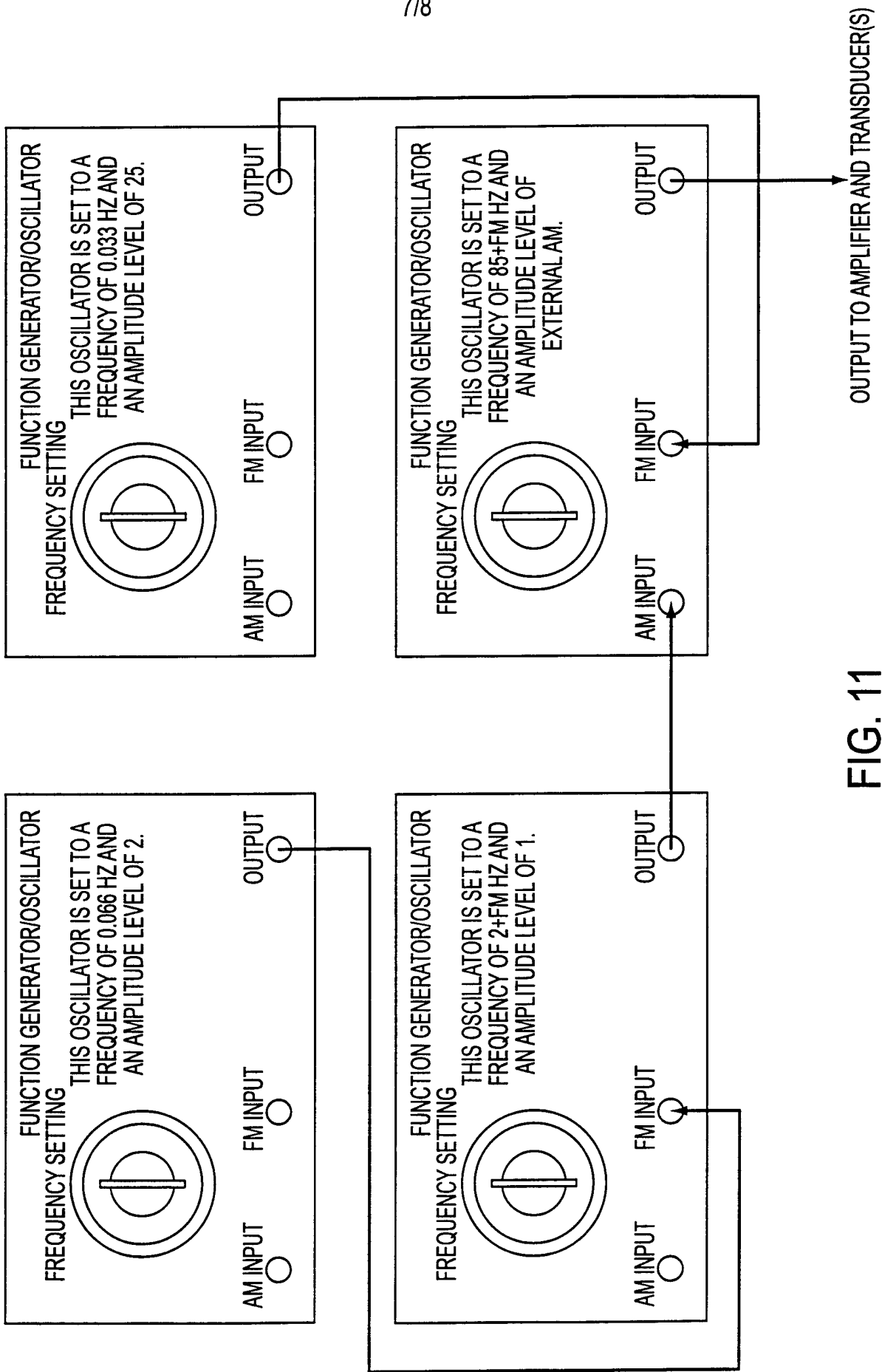

FIG. 11

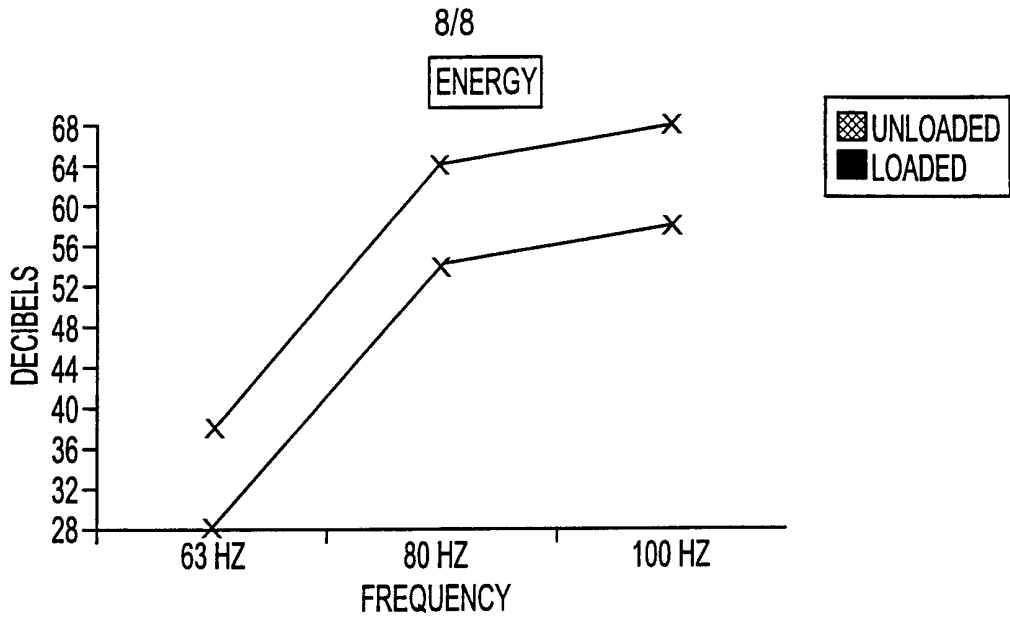

FIG. 12A

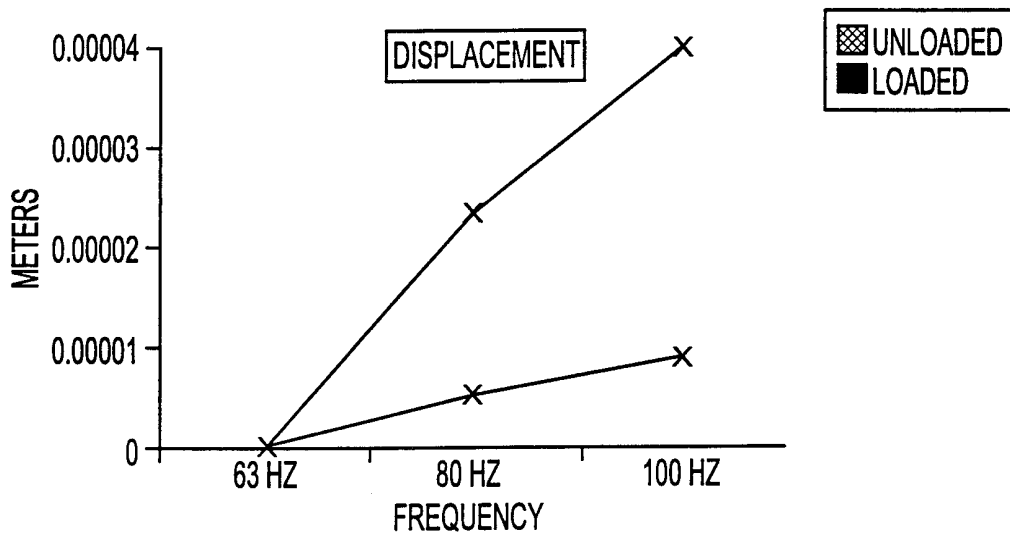

FIG. 12B

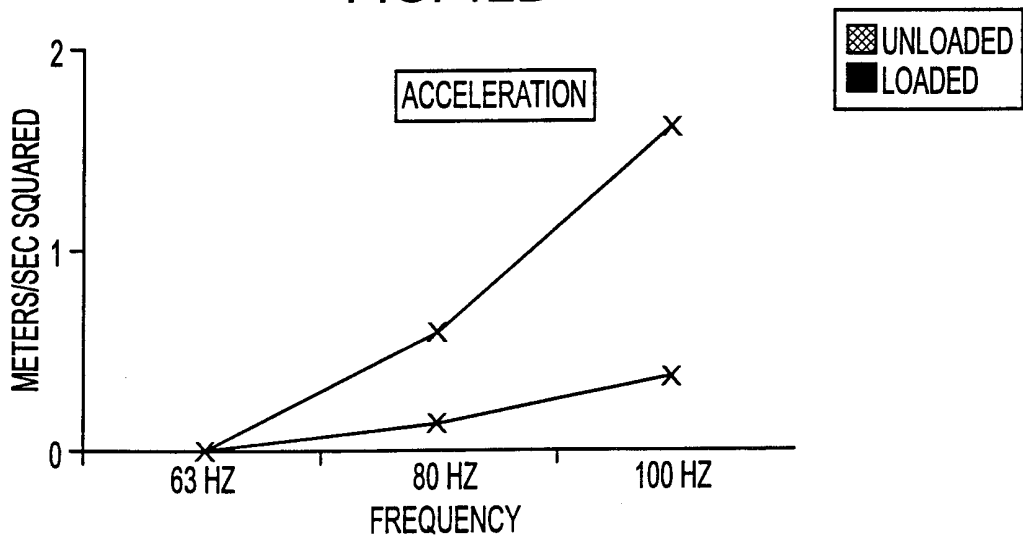

FIG. 12C

INTERNATIONAL SEARCH REPORT

Intr    ional Application No  
PCT/US 00/12912

**A. CLASSIFICATION OF SUBJECT MATTER**  
IPC 7    A61H23/02    A61H1/00    A47C21/00

According to International Patent Classification (IPC) or to both national classification and IPC

**B. FIELDS SEARCHED**  
Minimum documentation searched (classification system followed by classification symbols)  
IPC 7    A61H    A47C    H03C    H04L

Documentation searched other than minimum documentation to the extent that such documents are included in the fields searched

Electronic data base consulted during the international search (name of data base and, where practical, search terms used)  
EPO-Internal, WPI Data, PAJ

**C. DOCUMENTS CONSIDERED TO BE RELEVANT**

Category °	Citation of document, with indication, where appropriate, of the relevant passages	Relevant to claim No.
A	US 5 695 455 A (ALTON JR NOYAL JOHN ET AL) 9 December 1997 (1997-12-09) cited in the application column 3, line 19 - line 64	6
A	US 5 113 852 A (MURTONEN SALOMO) 19 May 1992 (1992-05-19) column 4, line 12 - line 50; figure 3	6
A	US 5 101 810 A (SKILLE OLAV ET AL) 7 April 1992 (1992-04-07) column 3, line 12 -column 4, line 9	6
A	US 4 370 602 A (JONES JR JOHNNY O ET AL) 25 January 1983 (1983-01-25) column 3, line 14 -column 5, line 22 column 8, line 14 - line 19	6
	-/-	

Further documents are listed in the continuation of box C.       Patent family members are listed in annex.

° Special categories of cited documents :

*A* document defining the general state of the art which is not considered to be of particular relevance	*T* later document published after the international filing date or priority date and not in conflict with the application but cited to understand the principle or theory underlying the invention
*E* earlier document but published on or after the international filing date	*X* document of particular relevance; the claimed invention cannot be considered novel or cannot be considered to involve an inventive step when the document is taken alone
*L* document which may throw doubts on priority claim(s) or which is cited to establish the publication date of another citation or other special reason (as specified)	*Y* document of particular relevance; the claimed invention cannot be considered to involve an inventive step when the document is combined with one or more other such documents, such combination being obvious to a person skilled in the art.
*O* document referring to an oral disclosure, use, exhibition or other means	*&* document member of the same patent family
*P* document published prior to the international filing date but later than the priority date claimed	

Date of the actual completion of the international search  22 August 2000	Date of mailing of the international search report  29/08/2000
---	--

Name and mailing address of the ISA European Patent Office, P.B. 5818 Patentlaan 2 NL - 2280 HV Rijswijk Tel. (+31-70) 340-2040, Tx. 31 651 epo nl, Fax: (+31-70) 340-3016	Authorized officer  Millward, R
--	---------------------------------------



# INTERNATIONAL SEARCH REPORT

International Application No

PCT/US 00/12912

## C.(Continuation) DOCUMENTS CONSIDERED TO BE RELEVANT

Category	Citation of document, with indication, where appropriate, of the relevant passages	Relevant to claim No.
A	US 4 232 661 A (CHRISTENSEN EARL A) 11 November 1980 (1980-11-11) column 2, line 50 - line 56 column 3, line 5 -column 4, line 24 column 5, line 33 -column 6, line 33 -----	6

# INTERNATIONAL SEARCH REPORT

information on patent family members

International Application No

PCT/US 00/12912

Patent document cited in search report		Publication date	Patent family member(s)	Publication date
US 5695455	A	09-12-1997	NONE	
US 5113852	A	19-05-1992	FI 884898 A AU 630630 B AU 4347589 A CA 2001388 A,C DE 68914466 D DE 68914466 T EP 0441802 A WO 9004379 A JP 6093905 B JP 4501073 T KR 133731 B	25-04-1990 05-11-1992 14-05-1990 24-04-1990 11-05-1994 28-07-1994 21-08-1991 03-05-1990 24-11-1994 27-02-1992 20-04-1998
US 5101810	A	07-04-1992	NO 861060 A AT 84962 T CA 1296391 A CN 1015148 B DK 606087 A,B, FI 875104 A,B, JP 7114811 B JP 63502806 T KR 9411208 B RU 2070020 C AU 7125687 A DD 265326 A DE 3687657 A DE 3687657 T EP 0244508 A ES 2040204 T WO 8705497 A	21-09-1987 15-02-1993 25-02-1992 25-12-1991 18-11-1987 18-11-1987 13-12-1995 20-10-1988 29-11-1994 10-12-1996 09-10-1987 01-03-1989 11-03-1993 02-09-1993 11-11-1987 16-10-1993 24-09-1987
US 4370602	A	25-01-1983	AU 3649678 A CA 1111948 A US 4371815 A	29-11-1979 03-11-1981 01-02-1983
US 4232661	A	11-11-1980	US RE31603 E	19-06-1984