



- (51) International Patent Classification:  
*G01V 3/32* (2006.01)    *G01V 3/38* (2006.01)
- (21) International Application Number:  
PCT/US2013/023782
- (22) International Filing Date:  
30 January 2013 (30.01.2013)
- (25) Filing Language: English
- (26) Publication Language: English
- (30) Priority Data:  
61/592,380    30 January 2012 (30.01.2012)    US
- (71) Applicant (for CA only): **SCHLUMBERGER CANADA LIMITED** [CA/CA]; 525-3rd Avenue Southwest, Calgary, Alberta T2P-0G4 (CA).
- (71) Applicant (for FR only): **SERVICES PETROLIERS SCHLUMBERGER** [FR/FR]; 42 rue Saint Dominique, F-75007 Paris (FR).
- (71) Applicant (for GB, JP, NL only): **SCHLUMBERGER HOLDINGS LIMITED** [GB/GB]; P.O. Box 71, Craigmuir Chambers, Road Town, 1110 Tortola (VG).
- (71) Applicant (for all designated States except AE, AO, BH, CA, CN, FR, GB, GH, IN, JP, LY, MA, MZ, NA, NG, NL, PH, SD, SY, US, VN): **SCHLUMBERGER TECHNO-**

**LOGY B.V.** [NL/NL]; Parkstraat 83-89m, NL-2514 JG The Hague (NL).

- (71) Applicant (for AE, AO, BF, BH, BJ, CF, CG, CI, CM, CN, GA, GH, GN, GQ, GW, IN, LY, MA, ML, MR, MZ, NA, NE, NG, PH, SD, SN, SY, TD, TG, VN only): **PRAD RESEARCH AND DEVELOPMENT LIMITED** [GB/GB]; P.O. Box 71, Craigmuir Chambers, Road Town, 1110 Tortola (VG).
- (71) Applicant (for US only): **SCHLUMBERGER TECHNOLOGY CORPORATION** [US/US]; 300 Schlumberger Drive, Sugar Land, Texas 77478 (US).
- (72) Inventors: **BENNETT, Nicholas N.**; 822 Ridge Road, Hamden, Connecticut 06517 (US). **VENKATARAMAN, Lalitha**; 61 Webb Street, Lexington, Massachusetts 020420 (US). **HEATON, Nicholas**; 4236 Purdue Street, Houston, Texas 77005 (US).
- (74) Agents: **LIU, Kenneth** et al.; 10001 Richmond Avenue, IP Administration Center of Excellence, Room 4720, Houston, Texas 77042 (US).
- (81) Designated States (unless otherwise indicated, for every kind of national protection available): AE, AG, AL, AM, AO, AT, AU, AZ, BA, BB, BG, BH, BN, BR, BW, BY, BZ, CA, CH, CL, CN, CO, CR, CU, CZ, DE, DK, DM, DO, DZ, EC, EE, EG, ES, FI, GB, GD, GE, GH, GM, GT,

[Continued on next page]

(54) Title: METHOD OF PERFORMING ERROR-CORRECTION OF NMR DATA

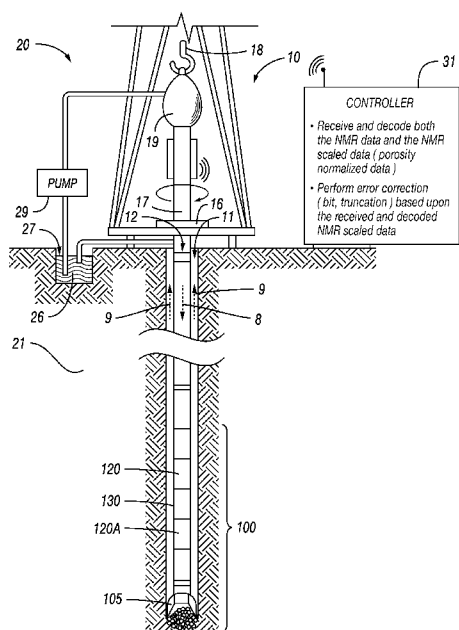


FIG. 1

(57) Abstract: A method of obtaining nuclear magnetic resonance (NMR) data from a subterranean formation may include operating a tool in a subterranean formation for generating both NMR data and NMR scaled data based upon NMR measurements of the subterranean formation. The method may also include operating the tool for encoding and transmitting both the NMR data and NMR scaled data, and receiving and decoding, above the subterranean formation, both the NMR data and NMR scaled data from the tool. The method may also include performing error-correction of the received and decoded NMR data based upon the received and decoded NMR scaled data.





HN, HR, HU, ID, IL, IN, IS, JP, KE, KG, KM, KN, KP, KR, KZ, LA, LC, LK, LR, LS, LT, LU, LY, MA, MD, ME, MG, MK, MN, MW, MX, MY, MZ, NA, NG, NI, NO, NZ, OM, PA, PE, PG, PH, PL, PT, QA, RO, RS, RU, RW, SC, SD, SE, SG, SK, SL, SM, ST, SV, SY, TH, TJ, TM, TN, TR, TT, TZ, UA, UG, US, UZ, VC, VN, ZA, ZM, ZW.

UG, ZM, ZW), Eurasian (AM, AZ, BY, KG, KZ, RU, TJ, TM), European (AL, AT, BE, BG, CH, CY, CZ, DE, DK, EE, ES, FI, FR, GB, GR, HR, HU, IE, IS, IT, LT, LU, LV, MC, MK, MT, NL, NO, PL, PT, RO, RS, SE, SI, SK, SM, TR), OAPI (BF, BJ, CF, CG, CI, CM, GA, GN, GQ, GW, ML, MR, NE, SN, TD, TG).

**(84) Designated States** (unless otherwise indicated, for every kind of regional protection available): ARIPO (BW, GH, GM, KE, LR, LS, MW, MZ, NA, RW, SD, SL, SZ, TZ,

**Published:**

— with international search report (Art. 21(3))

## METHOD OF PERFORMING ERROR-CORRECTION OF NMR DATA

### Background

[0001] Well placement has been developed over the years by providing logging while drilling (LWD) measurements at the surface or above the subterranean formation in real time, starting with gamma ray and resistivity logs, and more recently deeper directional electromagnetic measurements. In addition, there has been increasing interest in providing additional formation evaluation data at the surface in real time, such as, for example, nuclear magnetic resonance (NMR) echo train measurements. The NMR measurements can provide information concerning porosity, the distribution of pore sizes, fluid typing, and fluid composition. NMR echo train measurements are very high dimensional and may include both Carr, Purcell, Meiboom, and Gill (CPMG) and enhanced precision mode (EPM) burst measurements that include thousands of echoes.

[0002] To make these NMR echo measurements available at the surface in real time, compression algorithms may be used to convert the NMR data into a bitstream that can be transmitted to the surface using, for example, a mud-pulse telemetry system. These compression algorithms may employ entropy encoding. Because of this entropy encoding, these bitstreams may be susceptible to various types of transmission errors that can cause errors in the NMR data reconstructed at the surface.

### Summary

[0003] This summary is provided to introduce a selection of concepts that are further described below in the detailed description. This summary is not intended to identify key or essential features of the claimed subject matter, nor is it intended to be used as an aid in limiting the scope of the claimed subject matter.

[0004] A method of obtaining nuclear magnetic resonance (NMR) data from a subterranean formation may include operating a tool in a subterranean formation for

generating both NMR data and NMR scaled data based upon a plurality of NMR measurements of the subterranean formation. The method may also include operating the tool in the subterranean formation for encoding and transmitting both the NMR data and NMR scaled data, and receiving and decoding, above the subterranean formation, both the NMR data and NMR scaled data encoded and transmitted from the tool. The method may also include performing error-correction of the received and decoded NMR data based upon the received and decoded NMR scaled data.

**[0005]** A system aspect is for obtaining nuclear magnetic resonance (NMR) data from a subterranean formation. The system includes a tool positioned in a subterranean formation to generate both NMR data and NMR scaled data based upon a plurality of NMR measurements of the subterranean formation, and encode and transmit both the NMR data and NMR scaled data. The system also includes a controller positioned above the subterranean formation to receive and decode both the NMR data and NMR scaled data encoded and transmitted from the tool, and perform error-correction of the received and decoded NMR data based upon the received and decoded NMR scaled data.

**[0006]** A non-transitory computer readable medium aspect is for obtaining nuclear magnetic resonance (NMR) data from a subterranean formation. The non-transitory computer-readable medium has computer-executable instructions for decoding, above the subterranean formation, both NMR data and NMR scaled data that is encoded and transmitted from a tool operated in a subterranean formation. The tool generates both the NMR data and the NMR scaled data based upon NMR measurements of the subterranean formation. The computer-executable instructions perform error-correction of the received and decoded NMR data based upon the received and decoded NMR scaled data.

### **Brief Description of the Drawings**

**[0007]** FIG. 1 is a schematic diagram of a subterranean a well logging system for use with a method in accordance with an embodiment.

[0008] FIG. 2 is a flowchart of obtaining nuclear magnetic resonance (NMR) data in a subterranean formation in accordance with an embodiment.

[0009] Fig. 3 is a graph of reconstructed CPMG measurements from three candidate bitstreams according to an embodiment along with original CPMG measurements encoded in the subterranean formation.

[0010] FIG. 4 is a graph of reconstructed CPMG values versus possible codeword completions in accordance with an embodiment.

[0011] FIG. 5 is a graph of T2 probability density functions derived from the data in the graph of FIG. 4 and with and without error-correction.

[0012] FIG. 6 is a graph of reconstructed CPMG measurements from four candidate bitstreams according to an embodiment along with original CPMG measurements encoded in the subterranean formation.

### **Detailed Description**

[0013] The present description is made with reference to the accompanying drawings, in which example embodiments are shown. However, many different embodiments may be used, and thus the description should not be construed as limited to the embodiments set forth herein. Rather, these embodiments are provided so that this disclosure will be thorough and complete. Like numbers refer to like elements throughout.

[0014] Referring initially to FIG. 1 and the flowchart **40** in FIG. 2, a system **20** and corresponding method of obtaining nuclear magnetic resonance (NMR) data from a subterranean formation **21** is described.

[0015] The wellsite system **20** may be onshore or offshore, for example. A borehole **11** is formed in the subterranean formation **21**, for example, by rotary drilling. Of course,

the borehole **11** may be formed in the subterranean formation **21** using other techniques, for example, directional drilling.

[0016] A drill string **12** is suspended within the borehole **11** and has a bottom hole assembly **100** or tool which includes a drill bit **105** at its lower end. The system **20** includes a platform and derrick assembly **10** positioned over the borehole **11**. The assembly **10** includes a rotary table **16**, a kelly **17**, a hook **18**, and a rotary swivel **19**. The drill string **12** is rotated by the rotary table **16** and energized to engage the kelly **17** at the upper end of the drill string. The drill string **12** is suspended from the hook **18**, attached to a traveling block, through the kelly **17** and the rotary swivel **19** which permits rotation of the drill string relative to the hook. A top drive system could alternatively be used.

[0017] Drilling fluid or mud **26** may be stored in a pit **27** formed at the well site. A pump **29** delivers the drilling fluid **26** to the interior of the drill string **12** via a port in the swivel **19**, causing the drilling fluid to flow downwardly through the drill string **12** as indicated by the directional arrow **8**. The drilling fluid exits the drill string **12** via ports in the drill bit **105**, and then circulates upwardly through the annulus region between the outside of the drill string and the wall of the borehole **11**, as indicated by the directional arrows **9**. The drilling fluid lubricates the drill bit **105** and carries subterranean formation cuttings to the surface to be returned to the pit **27** for recirculation.

[0018] The bottom hole assembly **100** or tool includes a logging-while-drilling (LWD) module **120**, a measuring-while-drilling (MWD) module **130**, a roto-steerable system and motor, and drill bit **105**. The LWD module **120** is carried by a drill collar and may include one or more logging tools. Of course, more than one LWD and/or MWD module may be used, for example, as illustrated. It should be noted that references made herein to a module at the position **120** may alternatively correspond to a module at the position of **120A**. The LWD module **120** includes capabilities for measuring, processing, and storing information, and for communicating with the surface equipment. The LWD module **120** may include an NMR measuring device.

[0019] The MWD module **130** is also carried by a drill collar, and may include one or more devices for measuring characteristics of the drill string and drill bit. The MWD tool or module **130** may further include a device for generating electrical power to the downhole system, for example, a mud turbine generator powered by the flow of the drilling fluid. Of course, other types of power and/or battery systems may be used. The MWD module **130** may include one or more of the following types of measuring devices: a weight-on-bit measuring device, a torque measuring device, a vibration measuring device, a shock measuring device, a stick slip measuring device, a direction measuring device, and an inclination measuring device.

[0020] Measurements from the measuring devices of the LWD and/or MWD modules **120**, **130** may be sent, for example, wirelessly via wireless communications circuitry, to the surface for processing. For example, a controller **31** may control and log the measurements. The controller **31** may be in the form of one or more processors and a memory coupled thereto, and may include a database, for example. While a particular tool **100** has been described herein, it should be appreciated that a tool may include more or less components described above.

[0021] Beginning at Block **42**, the tool **100** is operated in a subterranean formation **21**, and more particularly, the borehole **11**, to collect NMR measurements (Block **44**). The tool **100**, while positioned in the subterranean formation **21** generates both NMR data and NMR scaled data based upon the NMR measurements of the subterranean formation (Block **46**). In some embodiments, the NMR scaled data includes porosity-scaled data, which may be normalized, for example, that is, scaled to a scale value of 1. In other embodiments, other types of NMR data may be collected, and scale values other than 1 may be used.

[0022] The tool **100** encodes (Block **48**) and transmits (Block **50**), for example wirelessly, both the NMR data and NMR scaled data (e.g., NMR porosity data and NMR porosity scaled data) to above the subterranean formation to the controller **31**. In some embodiments, the tool **100** may transmit both the NMR data and the NMR scaled data via a wired interface.

[0023] The tool **100** encodes the NMR scaled data by performing a transformation, which may be a linear transformation, for example, to generate corresponding transform coefficients. The transform coefficients are then entropy encoded, for example, Huffman encoded, to generate code words.

[0024] The controller **31**, which is positioned above the subterranean formation **21**, receives (Block **52**) and decodes (Block **54**) both the NMR data and NMR scaled data encoded and transmitted from the tool **100** below the subterranean formation. Indeed, when the encoded NMR data, including the code words, is transmitted to above the subterranean formation **21** and received by the controller **31**, errors may be introduced, as described in further detail below.

[0025] The controller **31** performs error-correction of the received and decoded NMR data based upon the received and decoded NMR scaled data (Block **56**). The controller **31** may perform one or more of bit error correction, or a truncation error correction, as described in further detail below. The controller **31** may perform the error-correction based upon the decoded NMR scaled data being within  $\pm 10\%$  of the scale value, for example. In some embodiments, the controller **31** may perform the error-correction based upon the decoded NMR scaled data being within  $\pm 5\%$  of the scale value. The method ends at Block **58**.

[0026] Further details and examples of the embodiments are now described. NMR measurements are collected from the tool **100**, for example, an NMR echo train measurement. The NMR echo train measurement is separated into two components: (a) the NMR porosity; and (b) the porosity-normalized NMR echo data. The NMR echo train measurement transmission may be separated because, for example, during drilling operations, NMR porosity may be used to derive other subterranean formation evaluation information.

[0027] Separating the NMR echo train measurements into NMR porosity and porosity-normalized NMR data may be accomplished by first representing the NMR echo measurements with a vector  $\vec{a}$  within a linear system of equations shown in Equation 1.

[0028] Equation 1:  $\mathbf{d} = \mathbf{K}f_{T_2}$

[0029] The vector  $f_{T_2}$  may describe the distribution of  $T_2$  relaxation times of the fluid components in the pore space of the subterranean formation, and  $\mathbf{K}$  is the kernel matrix describing the linear relationship between the vectors  $\mathbf{d}$  and  $f_{T_2}$ .

[0030] The NMR porosity  $\phi$  may then be estimated by solving Equation 1 for the vector  $f_{T_2}$  using, for example, a least squares technique and then adding together the entries of the vector as in Equation 2.

[0031] Equation 2:  $\phi = \int_0^\infty f_{T_2}(T_2) dT_2$

[0032] The porosity normalized NMR data may then be obtained by dividing the entries of the vector  $\mathbf{d}$  by the estimated NMR porosity  $\phi$ , as in  $\mathbf{d}/\phi$ . These porosity-normalized NMR data may then be scaled according to an arbitrary but fixed constant, for example, the constant 1 or, as another example, 100 porosity units (p.u.).

[0033] A consequence of separating the NMR echo train measurement transmission is that, at the surface or above the subterranean formation **21**, reconstructed porosity-normalized CPMG data should have values approximately equal to the scale value 1 at relatively early echo times. Alternatively, the porosity estimated from the reconstructed porosity-normalized NMR data may have values approximately equal to the scale value 1. This property can be used to correct at least two of the most common types of transmission errors including truncation errors and bit errors, as described below.

[0034] A truncation error may occur because during LWD operations, a fixed number of bits may be typically allocated to compress the NMR measurements so that a particular codeword may not be completely transmitted.

[0035] To describe a truncation error, the procedure for processing a set of transform coefficients, for example, singular value decomposition (SVD) transform coefficients is

described with reference to Table 1. The SVD transform coefficients shown in Column 2 of Table 1 may be computed by first decomposing the kernel matrix  $K$  described in Equation 1 into its SVD decomposition  $K = USV'$ . The SVD transform coefficients are then obtained by multiplying the SVD matrix  $U$  by the vector  $d/\phi$  of porosity-normalized NMR data, as described by  $U d/\phi$ . When a set of SVD transform coefficients are converted into a bitstream, each SVD transform coefficient is divided by a step size (that may depend on the SVD coefficient ID) and rounded to the nearest integer. This unconstrained symbol value refers to an entry in the corresponding Huffman coding table.

SVD Coeff ID	SVD Coeff	Step Size	Unconstrained Symbol Value	Min Symbol Value	Max Symbol Value	Codeword
1	-9.8671	0.488	-20	-67	-4	110000
2	-9.6782	0.508	-19	-31	32	001101
3	-2.6834	0.719	-4	-17	14	01110
4	-1.2216	0.346	-9	-13	18	11010
5	-0.0461	0.463	0	-8	7	1001
6	0.0844	0.456	0	-7	8	1000
7	-0.2730	0.837	0	-3	4	100

**Table 1**

Table 2 below shows the Huffman table for SVD coefficient 4.

Symbol Value	Huffman Codeword
-14	0 0 0 1 0 1 0 0 0

-13	0	0	0	1	0	1	0	0	1
-12	0	0	0	1	0	1	1		
-11	1	0	0	1	0	0	0		
<b>-10</b>	<b>1</b>	<b>1</b>	<b>0</b>	<b>1</b>	<b>1</b>				
<b>-9</b>	<b>1</b>	<b>1</b>	<b>0</b>	<b>1</b>	<b>0</b>				
-8	0	1	1	0					
-7	0	0	0	0					
-6	0	0	1	0					
-5	1	0	1	1					
-4	0	1	1	1					
-3	1	1	1	0					
-2	1	1	0	0					
-1	1	0	1	0					
0	1	1	1	1					
1	0	0	1	1					
<b>2</b>	<b>0</b>	<b>1</b>	<b>0</b>	<b>0</b>					
3	0	1	0	1					
4	1	0	0	0					
5	0	0	0	1	1				
6	1	0	0	1	1	1			
7	1	0	0	1	0	1			
8	1	0	0	1	0	0	1	1	
9	0	0	0	1	0	0			
10	1	0	0	1	1	0	0		
11	1	0	0	1	1	0	1	1	
12	1	0	0	1	1	0	1	0	1
13	0	0	0	1	0	1	0	1	0
14	0	0	0	1	0	1	0	1	1
15	1	0	0	1	0	0	1	0	0
16	1	0	0	1	0	0	1	0	1
17	1	0	0	1	1	0	1	0	0

**Table 2**

**[0036]** Suppose that the decoded bitstream includes the first three codewords described in Table 1 along with a portion of the fourth codeword:

110000 001101 01110 110

[0037] The '110' is enough information to infer that one of the three symbols highlighted or bolded above is being transmitted as the fourth SVD coefficient. This issue is referred to as a truncation error. The possible bitstreams that are consistent with the received bitstream can be enumerated similarly to the handling of the bit errors.

Candidate #1: 110000 001101 01110 110 **1 1**

Candidate #2: 110000 001101 01110 110 **1 0**

Candidate #3: 110000 001101 01110 110 **0**

[0038] The NMR data from these three bitstreams can be reconstructed and the corresponding values of porosity may be computed. These values of porosity may then be used to help distinguish which candidate codeword was actually transmitted as SVD Coefficient #4.

[0039] At the surface, the controller **31**, which may include decoder circuitry, determines if the portion of the bitstream corresponding to the last codeword has been truncated. If that is the case, the decoder's symbol frequency table could be used to estimate the last codeword from the truncated codeword. This estimation may lead to porosity normalized NMR data reconstructions where the CPMG data does not have early time values close to 1, for example, as illustrated in the graph **70** in FIG. 3. In the graph **70** the CPMG data **71** was reconstructed from a bitstream where the final codeword was determined to be candidate bitstream #3 using the symbol frequency table. Unlike the original (porosity-normalized) CPMG data **72**, the reconstructed CPMG data has relatively early time values that are far from 1. The curves **76** and **77** represent the CPMG echo data reconstructed from the candidate bitstreams #1 and #2. For this example, the truncation error correction mechanism produces the error corrected NMR data by averaging together the NMR data associated with candidate bitstreams #1 and #2.

[0040] An additional example of correcting truncation errors is now discussed. When the non-porosity component of the NMR data bitstream is truncated at 30 bits (or 18 bits or any number of bits), invariably the portion of the bitstream that describes the last

codeword is truncated. Because of the rapid decay of the transform coefficients (e.g., 8-10 yield a relatively high accuracy reconstruction of the NMR data when using the SVD-based methods, for example), the set of possible quantized SVD coefficient values that are consistent with the received bitstream at the surface can be enumerated, and the NMR echo train measurements for each one can be reconstructed. A small subset of these possible bitstream completions may lead to reconstructed porosity-normalized CPMG data values that are close to 1. This relatively small set of bitstream completions (and corresponding NMR data reconstructions) may be used to obtain a truncation error correction. As the bit budget for the porosity-normalized NMR echo train data decreases to 18 or 12 bits, for example, this truncation error correction mechanism may become increasingly desirable.

**[0041]** In an example, there are 96 possible sets of code words that are consistent with the received bitstream. These are enumerated on the x-axis of the graph **73** in FIG. 4. For each of these possible bitstream completions, the NMR measurements may be reconstructed and their early time CPMG values may be assessed, as shown on the y-axis. It is noted that among the possible symbol streams are the symbol stream associated with the untruncated data **75** and the symbol stream that could be constructed from the truncated bitstream using the symbol frequency table **74**. There are just 9 symbol streams which lead to acceptable CPMG reconstructions as shown by the diamond markers, some of which are indicated by **78**. For this example, the truncation error correction mechanism produces the error corrected NMR data by averaging together the NMR data associated with this small set of acceptable symbol streams.

**[0042]** This truncation error correction mechanism can make a relatively large difference for the T2 probability distributions functions (PDFs) derived at above the subterranean formation **21** or at the surface, for example.

**[0043]** Referring to the graph **80** in FIG. 5, the T2 PDFs that correspond to the symbol streams shown in the graph FIG. 4 are shown. The curve **82** represents original NMR measurements, the curve **84** represents data reconstructed from a truncated bitstream after error-correction, and the curve **86** represents data reconstructed from a truncated

bitstream using the symbol frequency table represented by **74** (FIG. 3). Indeed, using the truncation error correction mechanism or method described herein may lead to a significantly increased accuracy T2 distribution from the received NMR telemetry. Correcting the truncation error may lead to obtaining more accurate information from other NMR interpretations made at the surface or subterranean formation **21** - bound fluid volume, fluid typing, fluid composition in terms of chain length distributions, etc.

**[0044]** Another type of transmission error is a bit error. For example, when a mud-pulse telemetry system is used to transmit the NMR data to above the subterranean formation **21** or to the surface, the MWD receiver assigns a confidence level to each bit. This confidence level is between 0 and 100%. For the bitstream belonging to the NMR scaled data, or more particularly, the porosity-normalized data, the set of possible bitstreams that agree with the received bitstream for all the high-confidence level bits may be considered. For each of these candidate bitstreams, the NMR measurements can be reconstructed and assessed as to whether the early CPMG values are close to the scale value of 1. Alternatively, the porosity estimates from the reconstructed porosity-normalized NMR data should have values approximately equal to the scale value 1. A small subset of the candidate bitstreams may have early CPMG values close to 1, and this small subset represents a relatively simple bit error correction. Additionally, the method described herein may also be used to detect bit errors.

**[0045]** Of course, there may be other error correction mechanisms that may be considered for use with the embodiments described herein. For example, when there are burst measurements, CPMG measurements may be reconstructed to forward model the burst measurements to assess whether the burst measurements are indeed consistent with the reconstructed CPMG measurements.

**[0046]** An example of bit error correction using according to an embodiment is now described. Suppose that the MWD receiver indicates that bits 5 & 12 of the 30 bits used to compress the non-porosity component of the NMR data may not be necessarily trustworthy. These bits of a received bitstream are indicated in bold below:

1 1 1 1 1 1 1 0 1 0 0 0 0 0 0 1 1 1 1 0 1 0 0 0 0 0 0 0 1 1

[0047] There are 4 candidate bitstreams that agree with the received bitstream at all locations other than bits 5 & 12.

Candidate #1:

1 1 1 1 0 1 1 0 1 0 0 0 0 0 0 1 1 1 1 0 1 0 0 0 0 0 0 0 1 1

Candidate #2:

1 1 1 1 0 1 1 0 1 0 0 1 0 0 0 1 1 1 1 0 1 0 0 0 0 0 0 0 1 1

Candidate #3:

1 1 1 1 1 1 1 0 1 0 0 0 0 0 0 1 1 1 1 0 1 0 0 0 0 0 0 0 1 1

Candidate #4:

1 1 1 1 1 1 1 0 1 0 0 1 0 0 0 1 1 1 1 0 1 0 0 0 0 0 0 0 1 1

[0048] The NMR measurements may be reconstructed that correspond to these 4 bitstreams. The reconstructed CPMG measurements corresponding to the 4 bitstreams are illustrated by the curves **91**, **92**, **93**, **94**, respectively in the graph **90** in FIG. 6, along with the CPMG measurements that were encoded in the borehole **11** or within the subterranean formation **21**. The “correct” curve is represented by the curve **95**. Indeed, candidate bitstream **93** is the correct one, and bitstream **93** is the error corrected bit stream.

[0049] Another aspect is directed to a non-transitory computer-readable medium, for example, that may be included or part of the controller **31** above the subterranean formation **21**. The non-transitory computer-readable medium may include computer-executable instructions configured to perform steps that include decoding, above the subterranean formation, both NMR data and NMR scaled data encoded and transmitted from a tool operated in a subterranean formation. The tool generates both the NMR data and the NMR scaled data based upon NMR measurements of the subterranean formation. The computer-executable instructions are also configured to perform steps that include performing error-correction of the decoded NMR data based upon the decoded NMR

scaled data. Of course, the computer-executable instructions may also include other or additional instructions.

**[0050]** Many modifications and other embodiments will come to the mind of one skilled in the art having the benefit of the teachings presented in the foregoing descriptions and the associated drawings. Therefore, it is understood that various modifications and embodiments are intended to be included within the scope of the appended claims.

**That Which Is Claimed Is:**

1. A method of obtaining nuclear magnetic resonance (NMR) data from a subterranean formation comprising:
  - operating a tool in a subterranean formation for
    - generating both NMR data and NMR scaled data based upon a plurality of NMR measurements of the subterranean formation, and
    - encoding and transmitting both the NMR data and NMR scaled data;
  - receiving and decoding, above the subterranean formation, both the NMR data and NMR scaled data encoded and transmitted from the tool; and
  - performing error-correction of the received and decoded NMR data based upon the received and decoded NMR scaled data.
2. The method of Claim 1, wherein generating the NMR data comprises generating NMR porosity data, and wherein generating the NMR scaled data comprises generating NMR porosity-scaled data.
3. The method of Claim 1, wherein generating the NMR data comprises generating NMR porosity data, and wherein generating the NMR scaled data comprises generating NMR porosity-normalized data.
4. The method of Claim 1, wherein generating the scaled NMR data comprises generating the scaled NMR data with respect to a scale value; and wherein performing the error-correction comprises performing same based upon the decoded NMR scaled data being with  $\pm 10\%$  of the scale value.
5. The method of Claim 1, wherein encoding the NMR scaled data comprises:
  - performing a transformation to generate a plurality of transform coefficients; and
  - entropy encoding the plurality of transform coefficients to generate a plurality of code words.

6. The method of Claim 5, wherein performing the transformation comprises performing a linear transformation; and wherein entropy encoding comprises Huffman encoding.

7. The method of Claim 1, wherein performing the error-correction comprises performing truncation error correction.

8. The method of Claim 1, wherein performing the error-correction comprises performing bit error correction.

9. The method of Claim 1, wherein transmitting comprises wirelessly transmitting.

10. A system for obtaining nuclear magnetic resonance (NMR) data from a subterranean formation comprising:

a tool to be positioned in a subterranean formation to generate both NMR data and NMR scaled data based upon a plurality of NMR measurements of the subterranean formation, and

encode and transmit both the NMR data and NMR scaled data; and

a controller to be positioned above the subterranean formation to receive and decode both the NMR data and NMR scaled data encoded and transmitted from the tool, and perform error-correction of the received and decoded NMR data based upon the received and decoded NMR scaled data.

11. The system of Claim 10, wherein the NMR data comprises NMR porosity data, and wherein the NMR scaled data comprises NMR porosity-scaled data.

12. The system of Claim 10, wherein the NMR data comprises NMR porosity data, and wherein the NMR scaled data comprises NMR porosity-normalized data.

13. The system of Claim 10, wherein said tool is to generate the scaled NMR data with respect to a scale value; and wherein said controller is to perform the error-correction based upon the decoded NMR scaled data being with  $\pm 10\%$  of the scale value.

14. The system of Claim 10, wherein said tool is to encode the NMR scaled data by at least performing a transformation to generate a plurality of transform coefficients, and entropy encoding the plurality of transform coefficients to generate a plurality of code words.

15. A non-transitory computer readable medium for obtaining nuclear magnetic resonance (NMR) data from a subterranean formation, the non-transitory computer-readable medium having computer-executable instructions configured to perform the steps comprising:

decoding, above the subterranean formation, both NMR data and NMR scaled data encoded and transmitted from a tool operated in a subterranean formation, the tool generating both the NMR data and the NMR scaled data based upon a plurality of NMR measurements of the subterranean formation; and

performing error-correction of the decoded NMR data based upon the decoded NMR scaled data.

16. The non-transitory computer readable medium of Claim 15, wherein the NMR data comprises NMR porosity data, and wherein the NMR scaled data comprises NMR porosity-scaled data.

17. The non-transitory computer readable medium of Claim 15, wherein the NMR data comprises NMR porosity data, and wherein the NMR scaled data comprises NMR porosity-normalized data.

18. The non-transitory computer readable medium of Claim 15, the scaled NMR data is generated with respect to a scale value; and wherein performing the error-

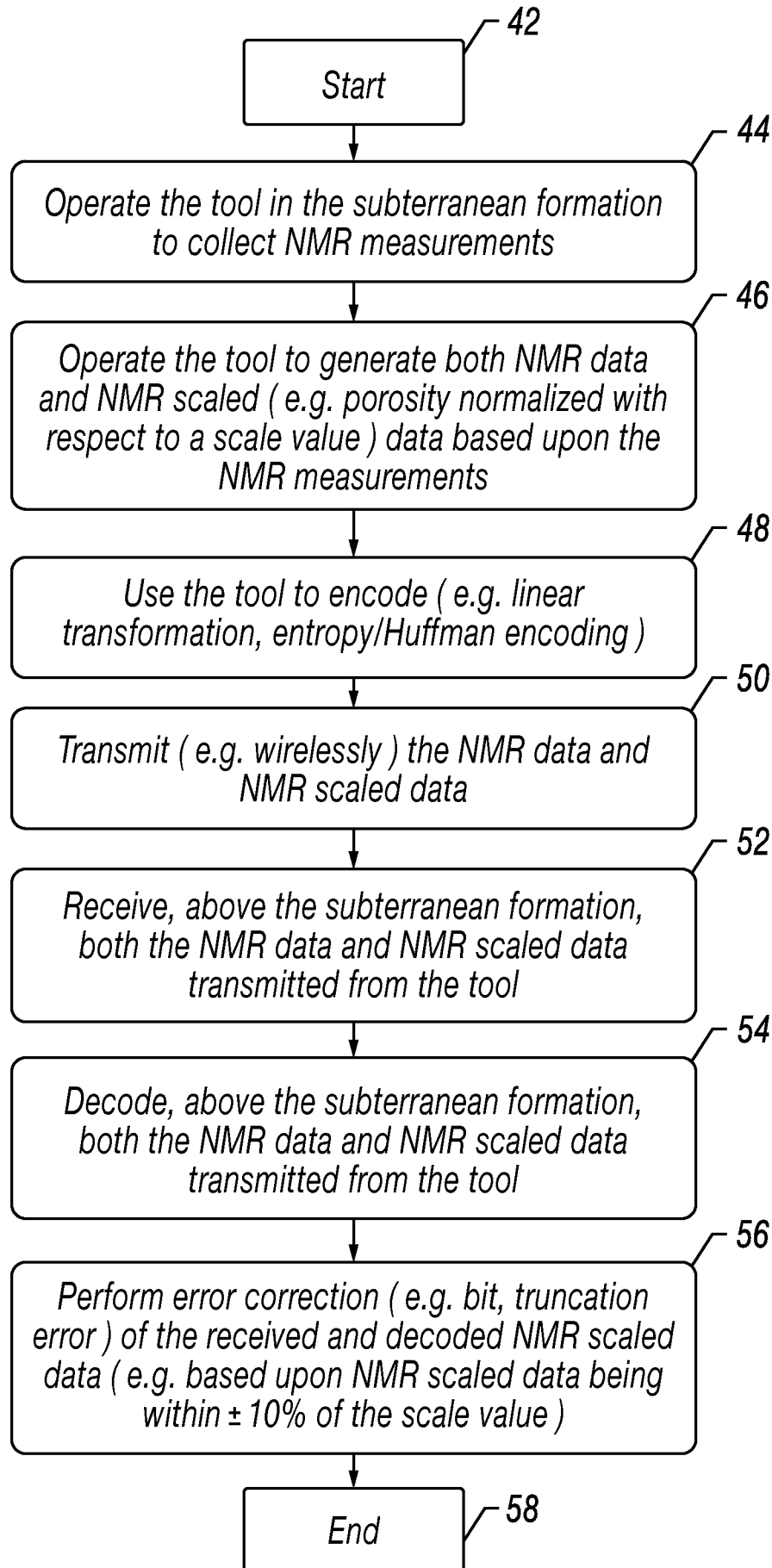
correction is based upon the decoded NMR scaled data being with  $\pm 10\%$  of the scale value.

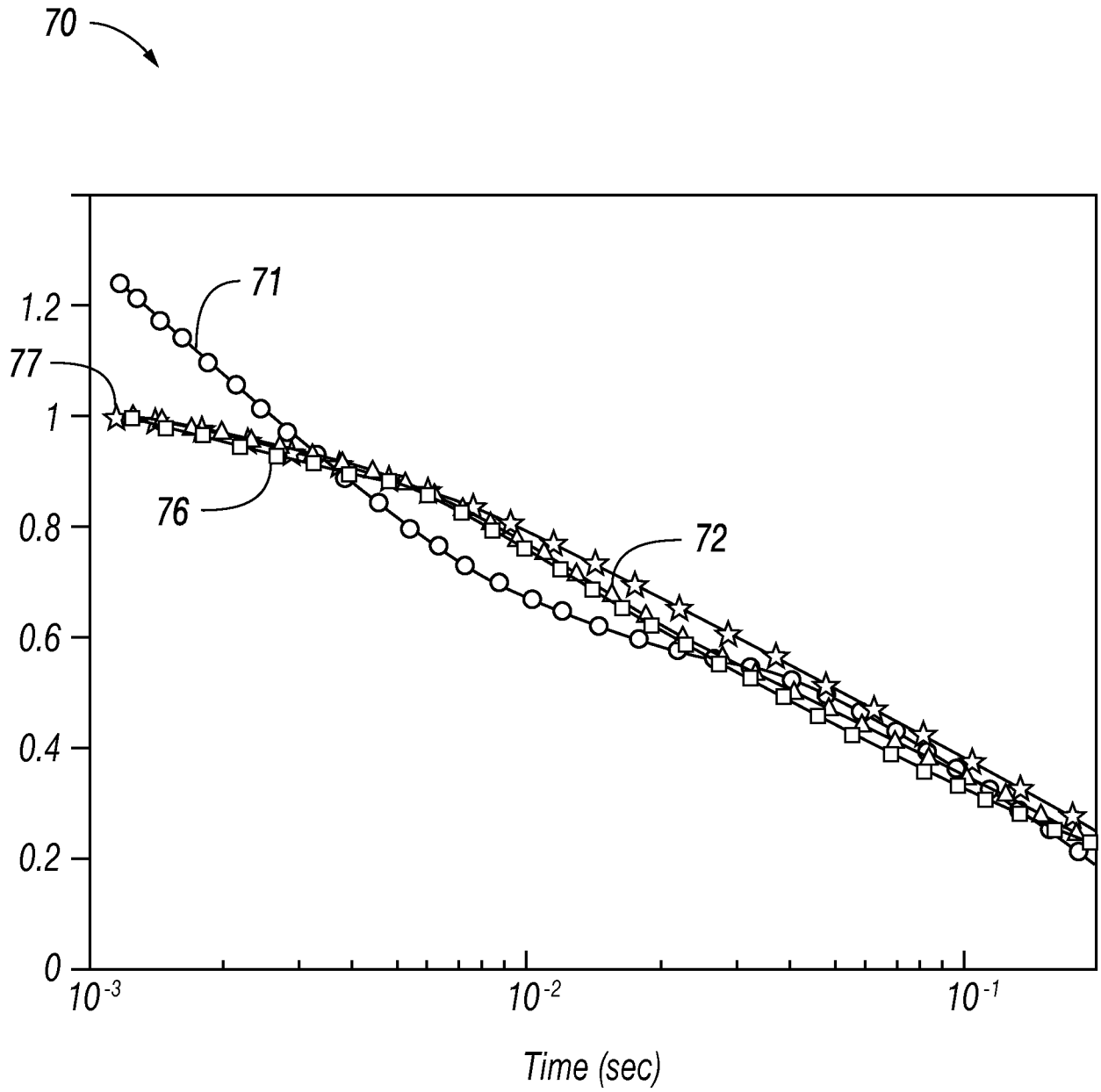
19. The non-transitory computer readable medium of Claim 15, wherein the NMR scaled data is encoded by at least performing a transformation to generate a plurality of transform coefficients, and entropy encoding the plurality of transform coefficients to generate a plurality of code words.

20. The non-transitory computer readable medium of Claim 15, wherein performing the error-correction comprises at least one of performing truncation error correction, and performing bit error correction.



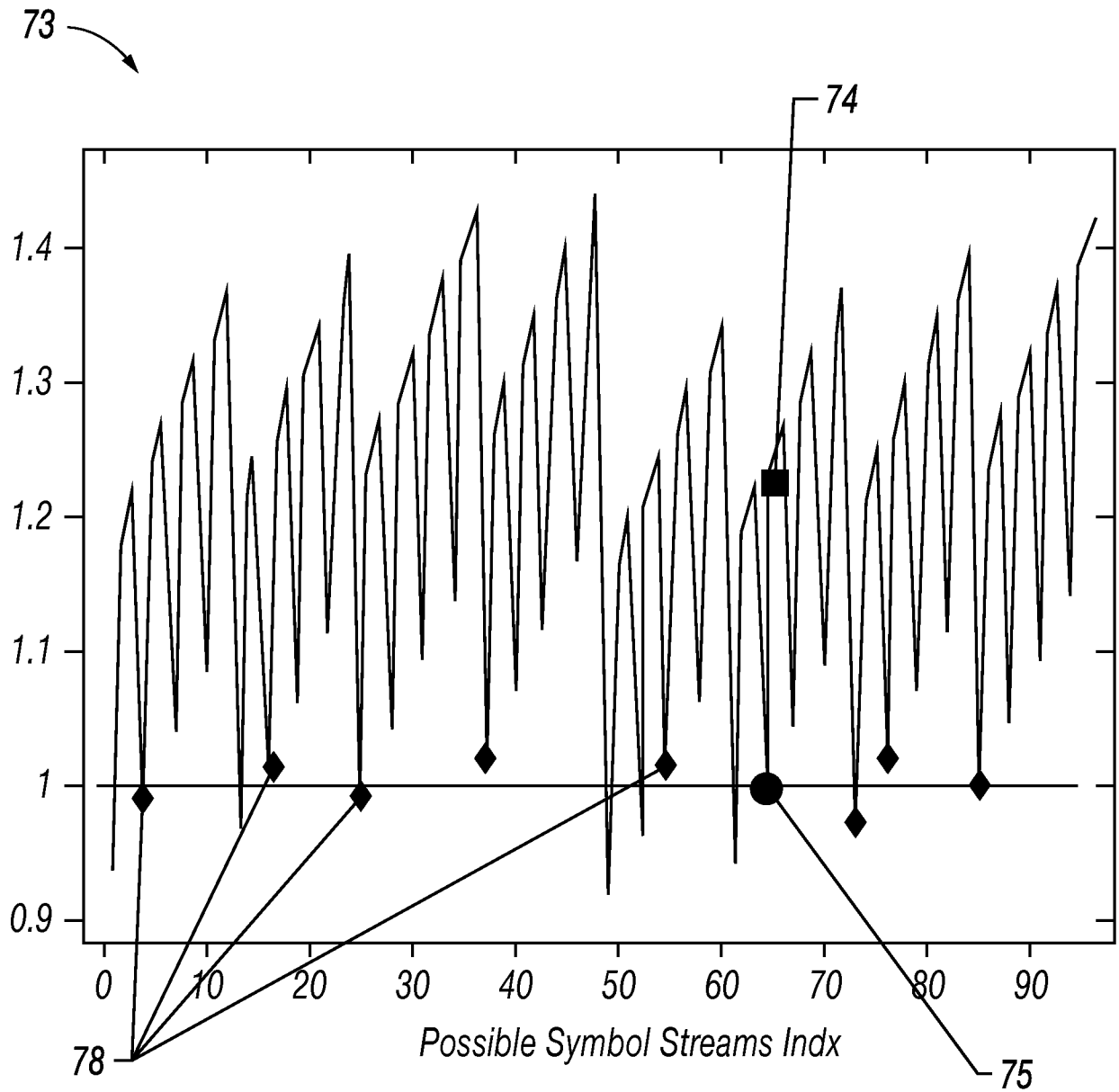
2/6

**FIG. 2**

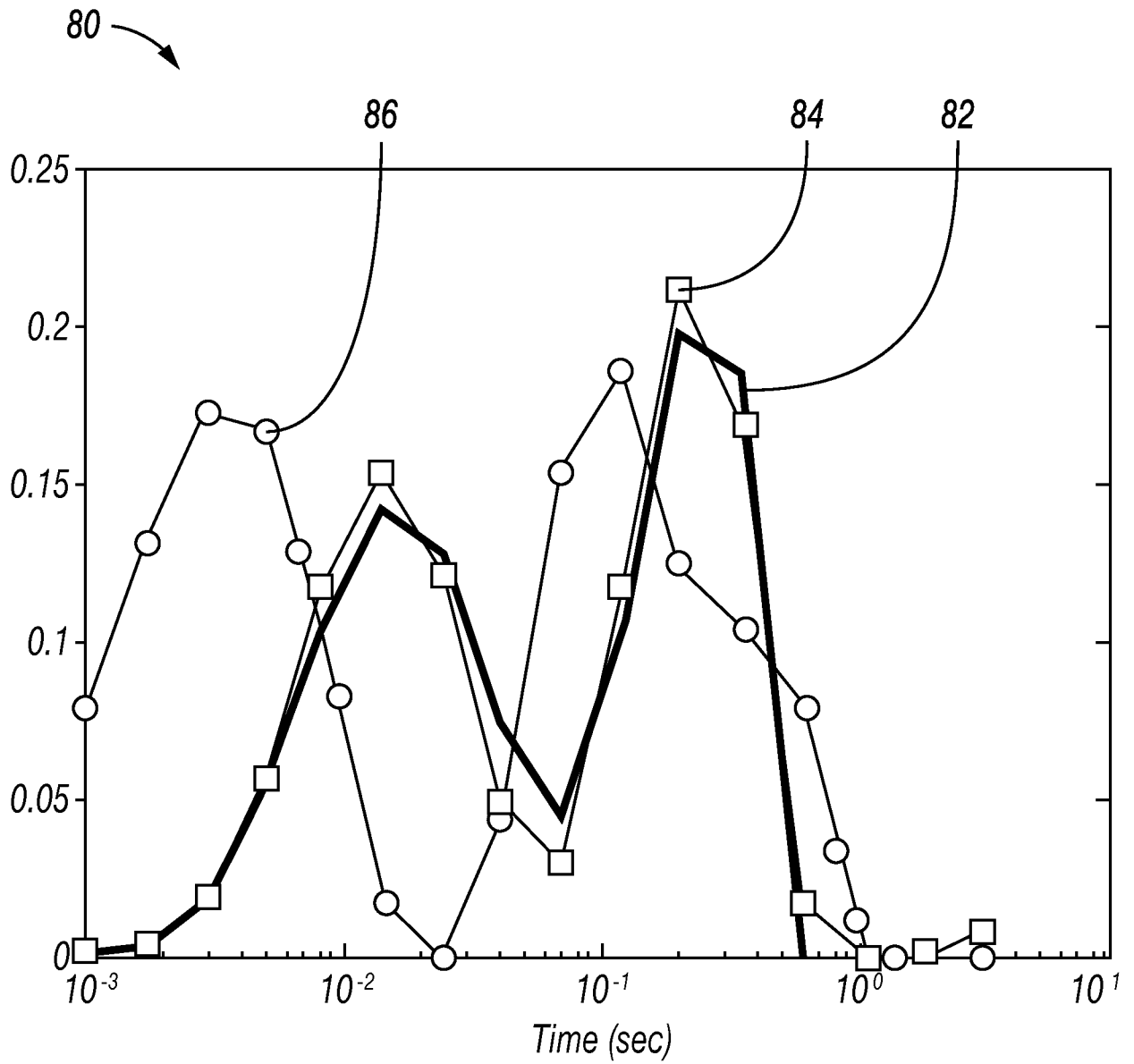


**FIG. 3**

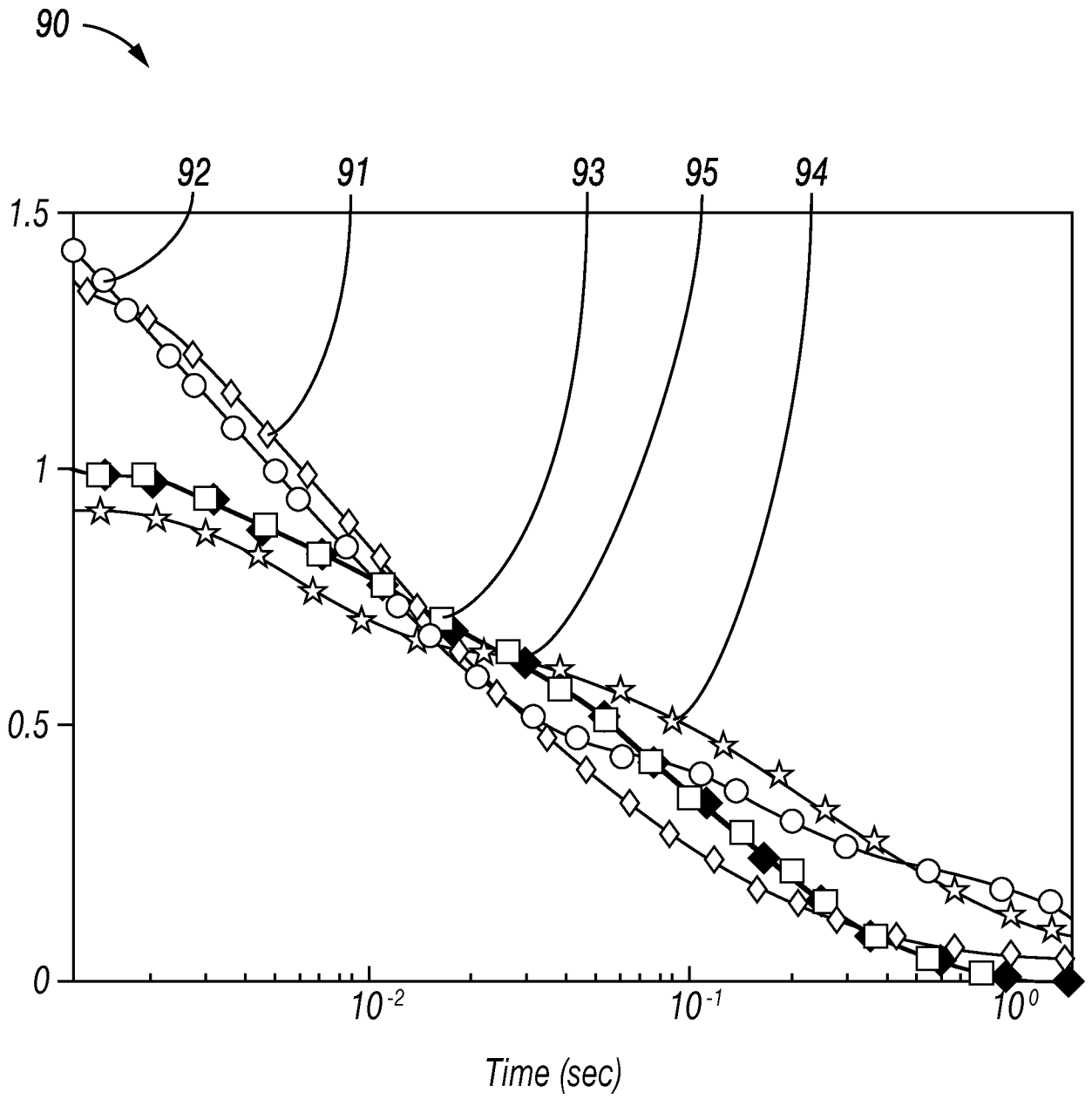
**SUBSTITUTE SHEET (RULE 26)**



**FIG. 4**





**FIG. 5**



**FIG. 6**

## INTERNATIONAL SEARCH REPORT

International application No.  
**PCT/US2013/023782**

<b>A. CLASSIFICATION OF SUBJECT MATTER</b>		
<i>G01V 3/32(2006.01)i, G01V 3/38(2006.01)i</i>		
According to International Patent Classification (IPC) or to both national classification and IPC		
<b>B. FIELDS SEARCHED</b>		
Minimum documentation searched (classification system followed by classification symbols) IPC: G01V 3/32; G01V 3/18, G01V 3/00		
Documentation searched other than minimum documentation to the extent that such documents are included in the fields searched Korean utility models and applications for utility models Japanese utility models and applications for utility models		
Electronic data base consulted during the international search (name of data base and, where practicable, search terms used) eKOMPASS(KIPO internal) & Keywords: NMR, formation, scaled data, error, correction, encoding, decoding, and similar terms		
<b>C. DOCUMENTS CONSIDERED TO BE RELEVANT</b>		
Category*	Citation of document, with indication, where appropriate, of the relevant passages	Relevant to claim No.
A	US 2004-0008027 A1 (PRAMMER, MANFRED) 15 January 2004 See abstract, paragraphs [0088],[0097],[0098],[0140],[0171],[0231],[0256]-[0261], claims 1-8,35, and figures 1,3.	1-20
A	US 6405136 B1 (LI et al.) 11 June 2002 See abstract, column 2 lines 49-54, column 4 line 64-column 6 line 19, column 7 line 1-column 8 line 36, claims 1,18, and figure 1.	1-20
A	US 2010-0245121 A1 (REED et al.) 30 September 2010 See abstract, paragraphs [0016],[0024]-[0027],[0037],[0053],[0065], claim 1, and figure 1.	1-20
A	US 2011-0005835 A1 (LI, JIANG) 13 January 2011 See abstract, paragraphs [0026]-[0032], claims 1,9,18, and figure 1.	1-20
A	US 2009-0198446 A1 (HURSAN, GABOR) 06 August 2009 See abstract, paragraphs [0027]-[0031], [0063], claims 1-17, and figures 1,12.	1-20
<input type="checkbox"/> Further documents are listed in the continuation of Box C. <input checked="" type="checkbox"/> See patent family annex.		
* Special categories of cited documents: "A" document defining the general state of the art which is not considered to be of particular relevance "E" earlier application or patent but published on or after the international filing date "L" document which may throw doubts on priority claim(s) or which is cited to establish the publication date of citation or other special reason (as specified) "O" document referring to an oral disclosure, use, exhibition or other means "P" document published prior to the international filing date but later than the priority date claimed "T" later document published after the international filing date or priority date and not in conflict with the application but cited to understand the principle or theory underlying the invention "X" document of particular relevance; the claimed invention cannot be considered novel or cannot be considered to involve an inventive step when the document is taken alone "Y" document of particular relevance; the claimed invention cannot be considered to involve an inventive step when the document is combined with one or more other such documents, such combination being obvious to a person skilled in the art "&" document member of the same patent family		
Date of the actual completion of the international search 13 May 2013 (13.05.2013)		Date of mailing of the international search report <b>14 May 2013 (14.05.2013)</b>
Name and mailing address of the ISA/KR  Korean Intellectual Property Office 189 Cheongsu-ro, Seo-gu, Daejeon Metropolitan City, 302-701, Republic of Korea Facsimile No. 82-42-472-7140		Authorized officer PARK, Jin Ho Telephone No. 0424818398 

## INTERNATIONAL SEARCH REPORT

Information on patent family members

International application No.

**PCT/US2013/023782**

Patent document cited in search report	Publication date	Patent family member(s)	Publication date		
US 2004-0008027 A1	15.01.2004	AU 1996-71172 B2	09.03.2000		
		CA 2449789 A1	12.12.2002		
		EP 0852737 A1	09.10.2002		
		EP 0852737 B1	03.11.2004		
		EP 1397708 A2	17.03.2004		
		GB 2418021 A	15.03.2006		
		US 2002-0167314 A1	14.11.2002		
		US 6242912 B1	05.06.2001		
		US 6512371 B2	28.01.2003		
		US 6956371 B2	18.10.2005		
		WO 02-099463 A2	12.12.2002		
		WO 2004-070423 A2	19.08.2004		
		WO 97-11674 A2	03.04.1997		
		WO 97-14063 A1	17.04.1997		
		US 6405136 B1	11.06.2002	GB 0024335 D0	22.11.2000
				GB 2358561 A	25.07.2001
				GB 2358561 B	03.07.2002
ID 27625 A	19.04.2001				
NO 20005156 A	17.04.2001				
NO 20005156 D0	13.10.2000				
US 2010-0245121 A1	30.09.2010	EP 2236744 A2	06.10.2010		
		US 8294591 B2	23.10.2012		
US 2011-0005835 A1	13.01.2011	GB 2486088 A	06.06.2012		
		NO 20120104 A	09.03.2012		
		WO 2011-005829 A2	13.01.2011		
		WO 2011-005829 A3	21.04.2011		
US 2009-0198446 A1	06.08.2009	AU 2009-209070 A1	06.08.2009		
		NO 20101085 A	26.08.2010		
		US 7705592 B2	27.04.2010		
		WO 2009-097510 A2	06.08.2009		
		WO 2009-097510 A3	12.11.2009		