

(51) International Patent Classification <sup>6</sup> : <b>B07C</b>		A2	(11) International Publication Number: <b>WO 96/06689</b>
			(43) International Publication Date: 7 March 1996 (07.03.96)
(21) International Application Number: PCT/IB95/00672		(74) Common Representative: BURROWS, Anthony, Gregory; Business Centre West, Avenue One, Business Park, Letchworth Garden City, Hertfordshire SG6 2HB (GB).	
(22) International Filing Date: 21 August 1995 (21.08.95)			
(30) Priority Data: 9416787.1 19 August 1994 (19.08.94) GB 9503472.4 22 February 1995 (22.02.95) GB		(81) Designated States: AM, AT, AU, BB, BG, BR, BY, CA, CH, CN, CZ, DE, DK, EE, ES, FI, GB, GE, HU, IS, JP, KE, KG, KP, KR, KZ, LK, LR, LT, LU, LV, MD, MG, MK, MN, MW, MX, NO, NZ, PL, PT, RO, RU, SD, SE, SG, SI, SK, TJ, TM, TT, UA, UG, US, UZ, VN, European patent (AT, BE, CH, DE, DK, ES, FR, GB, GR, IE, IT, LU, MC, NL, PT, SE), OAPI patent (BF, BJ, CF, CG, CI, CM, GA, GN, ML, MR, NE, SN, TD, TG), ARIPO patent (KE, MW, SD, SZ, UG).	
(71) Applicant (for all designated States except US): TIEDMANN-SJOH. H. ANDRESEN ANS [NO/NO]; Joh. H. Andresen Vei 5, N-0655 Oslo 6 (NO).			
(71) Applicant (for LU only): BURROWS, Anthony, Gregory [GB/GB]; Business Centre West, Avenue One, Business Park, Letchworth Garden City, Hertfordshire SG6 2HB (GB).		<b>Published</b> Without international search report and to be republished upon receipt of that report.	
(72) Inventors; and (75) Inventors/Applicants (for US only): ULRICHSEN, Borre, Bengt [NO/NO]; Holmenkollveien 33B, N-0376 Oslo (NO). MENDER, Clas, Frederik [NO/NO]; Eilert Sundts Gate 9, N-0259 Oslo (NO). FOSS-PEDERSEN, Geir [NO/NO]; Solvrevn 70, N-3033 Drammen (NO). TSCHUDI, Jon, Henrik [NO/NO]; Brinken 16B, N-0654 Oslo (NO). JOHANSEN, Ib-Rune [NO/NO]; Solligrenda 89, N-0491 Oslo (NO).			

(54) Title: DETERMINATION OF CHARACTERISTICS OF MATERIAL

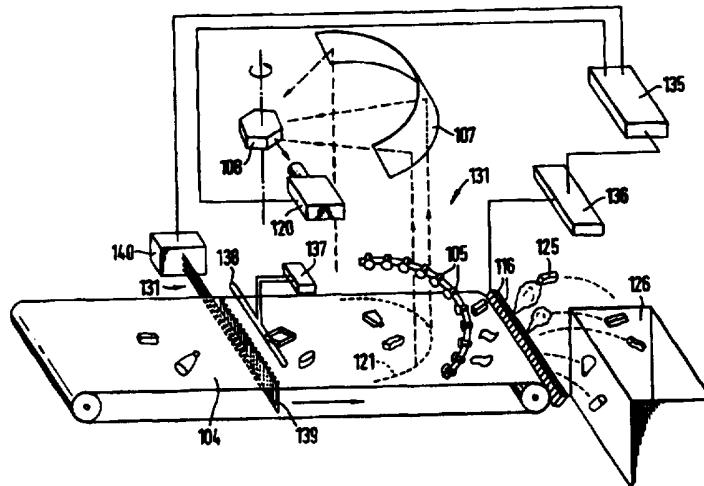

## (57) Abstract

A system for automatically inspecting matter for varying composition comprises one or more detection stations (131) through which one or more streams of matter are advanced and particular materials therein are detected through their diffusely reflected IR spectra, if any, and/or through their variation of an electromagnetic field by their metallic portions, if any. A row of light sources (105) distributed across the overall width of one or more belt conveyors (104) may cause desired portions (125) of the stream to reflect light diffusely onto a part-toroidal mirror (107) extending over that overall width, whence the light is reflected, by a rotating, polygonal mirror (108) through optical filters dedicated to differing IR wavelengths, onto detectors (120) the data output of which is utilised in controlling solenoid valves operating air jet nozzles (116) which separate-out the desired portions. Alternatively or additionally, an oscillator (137) and an antenna (138) which extends over that overall width generate an electromagnetic field through the belt (104) and sensing coils (139) sense variations therein produced by metallic portions of the stream passing through the detection station (131) and the detection data produced by the sensing coils (139) is used to control the solenoid valves operating the nozzles (116) to separate-out the metallic portions.

**FOR THE PURPOSES OF INFORMATION ONLY**

Codes used to identify States party to the PCT on the front pages of pamphlets publishing international applications under the PCT.

AT	Austria	GB	United Kingdom	MR	Mauritania
AU	Australia	GE	Georgia	MW	Malawi
BB	Barbados	GN	Guinea	NE	Niger
BE	Belgium	GR	Greece	NL	Netherlands
BF	Burkina Faso	HU	Hungary	NO	Norway
BG	Bulgaria	IE	Ireland	NZ	New Zealand
BJ	Benin	IT	Italy	PL	Poland
BR	Brazil	JP	Japan	PT	Portugal
BY	Belarus	KE	Kenya	RO	Romania
CA	Canada	KG	Kyrgystan	RU	Russian Federation
CF	Central African Republic	KP	Democratic People's Republic of Korea	SD	Sudan
CG	Congo	KR	Republic of Korea	SE	Sweden
CH	Switzerland	KZ	Kazakhstan	SI	Slovenia
CI	Côte d'Ivoire	LI	Liechtenstein	SK	Slovakia
CM	Cameroon	LK	Sri Lanka	SN	Senegal
CN	China	LU	Luxembourg	TD	Chad
CS	Czechoslovakia	LV	Latvia	TG	Togo
CZ	Czech Republic	MC	Monaco	TJ	Tajikistan
DE	Germany	MD	Republic of Moldova	TT	Trinidad and Tobago
DK	Denmark	MG	Madagascar	UA	Ukraine
ES	Spain	ML	Mali	US	United States of America
FI	Finland	MN	Mongolia	UZ	Uzbekistan
FR	France			VN	Viet Nam
GA	Gabon				

DETERMINATION OF CHARACTERISTICS OF MATERIAL

This invention relates to determination in first and second dimensions of characteristics of material, for example automatic inspection and sorting of discrete objects of differing compositions, e.g. waste objects, or automatic inspection of sheet material, which may be in the form of a strip, for surface layer composition, e.g. surface layer thickness.

With the recent focus on collection and recycling of waste, the cost effectiveness of waste sorting has become an essential economic parameter.

In the "Dual System" in Germany all recyclable "non-biological" packaging waste excluding glass containers and newsprint is collected and sorted in more than 300 sorting plants.

Objects can be sorted on the basis of:-

Size

Density/weight

Metal content (using eddy current effect)

Ferrous metal content (using magnetic separation)

but most objects such as plastics bottles and beverage cartons are today sorted out manually. Some beverage cartons contain an aluminium barrier and by eddy current induction they can be expelled from the waste stream. Generally, beverage cartons in their simpler form present a composite object consisting of paperboard with polymer overcoats on both their inside and outside surfaces.

To make a positive identification by automatic means is very difficult. Physical shape is normally quite distorted, making any camera-based recognition very complex unless the printing pattern is made in a specially recognisable way, or the carton is equipped with a recognisable marker or tracer.

Several sorting systems exist today that can sort a number of different plastics bottles/objects from each other when they arrive sequentially (i.e. one-by-one). The detection is based on reflected infrared spectrum analysis. To separate the various polymers a quite elaborate variance analysis has to be performed and thus detection systems become expensive. The objects being fed sequentially pass

beneath the infrared spectral detector whereby infrared is shone onto the objects and the relative intensities of selected wavelengths of the infrared radiation reflected are used to determine the particular plastics compound of the plastics passing beneath the detection head. Downstream of the detection head are a number of air jets which blow the individual plastics objects into respective bins depending upon the plastics which constitutes the majority of the object.

10 A similar system is disclosed in US-A-5,134,291 in which, although the objects to be sorted can be made of any material, e.g. metals, paper, plastics or any combination thereof, it is critical that at least some of the objects be made predominantly from PET (polyethylene terephthalate) and PS (polystyrene) as well as predominantly from at least two of PVC (polyvinyl chloride), PE (polyethylene) and PP (polypropylene), for example objects including: an object made predominantly from PET, an object made predominantly from PS, an object made predominantly from PVC and an object made predominantly from PE. A source of NIR (Near Infra Red), preferably a tungsten lamp, radiates NIR onto a conveyor sequentially advancing the objects, which reflect the NIR into a detector in the form of a scanning grating NIR spectrometer or a diode array NIR spectrometer. The detector is connected to a digital computer connected to a series of solenoid valves controlling a row of air-actuated pushers arranged along the conveyor opposite a row of transverse conveyors. The diffuse reflectance of the irradiated objects in the NIR region is measured to identify the particular plastics of each object and the appropriate solenoid valve and thus pusher are operated to direct that object laterally from the conveyor onto the appropriate transverse conveyor. The computer can manipulate data in the form of discrete wavelength measurements and in the form of spectra. A measurement at one wavelength can be ratioed to a measurement at another wavelength. Preferably, however, the data is manipulated in the form of spectra and the spectra manipulated, by analogue signal processing and digital pattern recognition, to make the differences more apparent and the resulting identification more reliable.

DE-A-4312915 discloses the separation of plastics, particularly of plastics waste, into separate types, on the basis of the fact that some types of plastics have characteristic IR spectra. In the IR spectroscopic procedure, the intensity of diffusely reflected radiation from each sample is measured on a discrete number of NIR wavelengths simultaneously and the intensities measured are compared. Measurements are taken on wavelengths at which the respective types of plastics produce the minimum intensities of reflected radiation. If, for example, three different plastics are to be separated, each sample is measured on three wavelengths simultaneously, whereby one type of plastics is identified in a first comparison of the intensity of the reflected radiation on the lowest wavelength with that of the second-lowest wavelength and the other two types of plastic are determined in a second comparison of the greater intensity on one wavelength in the first comparison with the intensity on the third wavelength. To measure the light on particular wavelengths, respective detectors can have narrow band pass filters for the respective requisite wavelengths, and respective constituent cables of a split optical fibre cable are allocated to the respective detectors, the cable entry lying in the beam path of a lens for detecting the light reflected from the sample. Alternatively, a light dispersing element, e.g. a prism or grid, is placed in the beam path after the lens and several detectors are arranged to detect the NIR of the requisite wavelengths. Sorting facilities are controlled by utilising the detection data obtained by the comparisons. As a further example, five differing plastics, namely PA (polyamide), PE, PS, PP and PETP, may be separated, utilising measurement points at five differing wavelengths between 1500nm. and 1800nm.

EP-A-557738 discloses an automatic sorting method with substance-specific separation of differing plastics components, particularly from domestic and industrial waste. In the method, light is radiated onto the plastics components, or the plastics components are heated to above room temperature, light emitted by the plastics components and/or light allowed through them (in an embodiment in which

light transmitted through the components and through a belt conveying them is measured) is received on selected IR wavelengths, and the material of the respective plastics components is identified from differences in intensity (contrast) between the light emitted and/or absorbed, measured on at least two differing wavelengths. The light emitted or allowed through is received by a camera which reproduces it on a detector through a lens. A one-dimensional line detector is usable, although a two-dimensional matrix detector or a one-element detector with a scanning facility can be employed. In order that the camera may receive the light on selected IR wavelengths, interference filters may be mounted either in front of the light source or in front of the lens or the detector. In an example in which the material of the plastics components is identified from the differences in intensity of emitted light at two differing wavelengths, the wavelengths are chosen to produce maximum contrast. This means that one wavelength is selected so that maximum intensity of the emitted light is obtained at a specified viewing angle, whereas the other wavelength is selected so that minimum intensity is obtained at that viewing angle. Changing of wavelengths may be achieved by mounting the filters on a rotating disc, with the frequency of rotation being synchronised with the imaging frequency of the detector. Alternatively, an electrically triggered, turnable, optical filter may be employed. The electrical signals generated by the detector are fed to an electronic signal processor, digitised, and subsequently evaluated by image processing software. It is ensured that the plastics components are at approximately the same temperature at the time of imaging, as differences in contrast can also be caused by temperature differences. The belt should consist of a material which guarantees constant contrast on individual wavelengths.

There is also previously known a system in which infrared spectral detection is performed from below the objects, with the objects passing sequentially over a hole up through which the IR is directed. Again, the infrared reflected is used to sort the objects according to the

various plastics within the respective objects.

In an eddy current system for ejecting metal from a stream of waste, the discharge end roller of a belt conveyor normally contains a strong alternating magnetic field generated by permanent magnets contained within and distributed along the roller and counter-rotating relative to the sense of rotation of the roller. This field ejects metallic objects to varying degrees depending upon the amount and the conductivity of the metal of the object. Since metallic objects in which the metal content is small, for example post-consumer packaging cartons of a laminate consisting of polymer-coated paperboard and aluminium foil, are only weakly affected by the magnetic field, such cartons tend not to be separated-out by the eddy-current ejection system.

Another known system uses an electromagnetic field for eddy current detection through induction of eddy currents in the metal in metallic objects and the detection output is used to control an air jet ejection arrangement but this time the objects are caused to queue up one after another in single lines.

Various systems are known for automatic inspection of a continuous strip of sheet material. One system includes a mechanical scanner reciprocated across the width of the strip as the latter advances past the scanner. Light containing IR is shone onto a transverse section of the strip and the scanner includes a transducer which detects the reflected IR at a plurality of locations across the section and emits electrical signals representing, for instance, the polymer layer thickness of a polymer layer/paperboard layer laminate. This is employed in a laminating machine to control the thickness of polymer deposited onto the paperboard.

US-A-4996440 discloses a system for measuring one or a plurality of regions of an object to be able to determine one or a plurality of dimensions of the object. In one example, the system utilises a mirror arrangement for transmitting pulsed laser light so that the light impinges downwards upon the object and for receiving the upwardly reflected light. The system includes a laser, a rotating

planar mirror and a concave frusto-conical mirror encircling the planar mirror, which serve for directing the light beam towards the object. The frusto-conical mirror, the planar mirror and a light receiver serve for receiving light beams which are reflected from the object. Electronic circuitry connected to the light receiver serves for calculating the travel time of the beam to and from the object, with a modulator causing the light beam to be modulated with a fixed frequency and the rotating planar mirror and the frusto-conical mirror causing the light beam to sweep across the object at a defined angle/defined angles relative to a fixed plane of reference during the entire sweeping operation.

According to a first aspect of the present invention, there is provided a method of automatically inspecting matter for varying composition, comprising advancing a stream of said matter through a detection station, emitting a detection medium to be active at a transverse section of said stream at said detection station, wherein said medium is varied by variations in the composition of said matter at said transverse section, receiving the varied medium at receiving means, and generating detection data in dependence upon the variations in said medium, characterised in that said varied medium is received over substantially the width of the stream by said receiving means which physically extends across substantially the width of said stream.

According to a second aspect of the present invention, there is provided apparatus for automatically inspecting matter for varying composition, comprising advancing means for advancing a stream of said matter, a detection station through which said advancing means advances said stream, emitting means serving to emit a detection medium to be active at a transverse section of said stream at said station, receiving means at said station serving to receive detection medium varied by variations in the composition of said matter at said section and detecting means serving to generate detection data in dependence upon the variations in said medium, and data-obtaining means connected to said detecting means and serving to obtain said detection data therefrom, characterised in that said receiving means is

arranged to extend physically across substantially the width of said stream.

Owing to these aspects of the present invention, it is possible for the stream to be relatively wide, so that the inspection rate can be increased.

By applying multiple sensors and/or a scanning system, it becomes possible to introduce a large number of detection points.

The detection medium can be electromagnetic radiation, for example IR or visible light to detect variations in constituency or colour, or an electromagnetic field to detect metal portions of the stream, e.g. in sorting of materials. A wide variety of materials may be sorted from each other, but particularly plastics-surfaced objects sorted from other objects. For the present automatic sorting, the objects must be distributed in substantially a single layer.

Preferably, for sorting of objects, the objects are advanced through the detection station on an endless conveyor belt. If the objects to be separated-out are plastics objects which are substantially transparent to the electromagnetic radiation, e.g. IR, then the conveying surface of the belt should be diffusely reflective of the electromagnetic radiation.

For a polymer, two or more detection wavelength bands in the NIR region of 1.5 microns to 1.85 microns can be employed. For a laminate comprised of polyethylene on paperboard, a first wavelength band centred on substantially 1.73 microns is employed, as well as a second wavelength band centred less than 0.1 microns from the first band, for example at about 1.66 microns.

The matter may comprise laminate comprised of a first layer and a second layer underneath said first layer and of a material having a spectrum of reflected substantially invisible electromagnetic radiation significantly different from that of the material of the first layer. As a result, the spectrum of substantially invisible electromagnetic radiation; particularly IR, reflected from such laminate can be readily distinguishably different from the spectrum of that radiation reflected from a single layer of the material

of either of its layers.

Using substantially invisible electromagnetic radiation, particularly IR, has the advantage of permitting more effective determination of the composition of the first layer.

In cases where the first layer is a polymer, e.g. polyethylene, for the diffusely reflected IR from the substrate to be sufficient for detection purposes, the first layer should be no more than 1mm. thick. Its thickness is advantageously less than 100 microns, preferably less than 50 microns, e.g. 20 microns.

If the stream is a continuous strip of laminate advancing on a laminating machine, for example a polymer coating machine coating a polymer layer onto a substrate, it is possible to detect any variation in composition of the advancing polymer layer and to correct the coating process accordingly.

Alternatively, it is possible to separate-out objects, e.g. waste objects, of a predetermined composition from a stream of matter, e.g. waste matter, which can be relatively wide compared with a sequential stream, so that a relatively high rate of separation can be achieved.

Typically, there could be a transverse row of some 25 to 50 detection points for a stream 1m. wide. A central detection system can be applied to "serve" all 25 to 50 detection points if there is sufficient IR intensity across the width of the stream from a single or multiple IR source or even if there is an infrared source at each detection point. Optical fibres may lead the reflected IR from the detection points to this central detection system. However, a system of IR reflectors is preferred to optical fibres, since a reflector system is less expensive, allows operation at higher IR intensity levels (since it involves lower IR signal losses) and is less demanding of well-defined focal depths. If the stream moves at some 2.5 m/sec. and the system is capable of 100 to 160 scans across the stream each second, then detections can be made at a spacing of some 2.5 to 1.5cm along the stream. When each scan is divided into 25 to 50 detection points, detections can be made in a grid of from 1.5 x 2.0cm. to 2.5 x 4.0cm.

The transverse scanning of the moving stream makes it possible to construct a two-dimensional simulation which can be analyzed using image processing. In this way it is possible to detect:

5 matter composition, e.g. thickness, and position in the stream

shape and size of composition variation  
several composition variations substantially simultaneously.

10 The detection data processing system will determine wanted/unwanted composition at each point.

For thickness measurement of a surface polymer coating of a packaging web comprised of a paperboard substrate and the polymer coating on the substrate, the apparatus scans the moving web and measures the thickness of the polymer coating by monitoring two lines in the IR spectrum. The IR passes through the polymer and is partially absorbed on the way. When past the polymer layer it meets the paperboard substrate, which diffusely reflects the IR. The diffusely reflected IR travels back through the polymer and is again partially absorbed. The diffusely reflected IR leaving the polymer surface passes to a detector which reads the incoming IR. The absorption will be a measure of "absorption length", viz. the thickness of the polymer layer. The two IR lines are chosen so that one is largely absorbed in the polymer and the other not, so functioning as a reference. Both IR lines are chosen to have low absorption in fibre.

20  
30 The rough fibre surface largely gives diffuse reflection, while the polymer mainly gives direct reflection, which is not measured.

For food quality control, the apparatus measures the quality of foodstuff by monitoring the absorption spectrum in the IR range. Fat content and maturing of fish, and the maturing of meat is today measured by single detectors only capable of single point measurements. Only the low range of the IR spectrum (<1micron) is currently used, restricting the available information. The present apparatus enables much wider analysis in the IR spectrum, and also enables an almost continuous total quality control.

40

In separating beverage cartons from a stream of waste, the signals from each of the wavelength bands are combined using signal processing for each detection. The two-dimensional simulation which is built up as the stream passes the detection station can be processed using robust statistical data analysis. For example, a logical rule may be applied where a minimum cluster of positive detections, for instance 3 x 3, is required before the system recognises a possible beverage carton. In high speed systems (e.g., 2.5m./sec. belt speed) only slight air pulses (an air cushion) are required to alter the carton exit trajectory from the belt sufficiently that they can land in a bin separate from other objects dropping freely. Normally, some 15-30 positive detections are made on a 1 litre carton. The peripheral detection points in the clusters can thus advantageously be disregarded, only initiating the air pulses according to the interior detection points, so securing more lift than tilt.

In slower speed systems (e.g., 0.2-0.5m/sec belt speed) more positive air ejection pulses may be required to expel the cartons from the remaining stream. This requires air pulses hitting the cartons near their centres of gravity to avoid uncontrolled ejection trajectories.

Although an advantage of arranging the detection of objects from underneath (rather than above) the waste stream is that it gives as uniform a distance from detection point to object as possible, it has disadvantages which more than outweigh that advantage. By irradiating the waste objects on a conveyor belt with radiation from above and by utilising a reflector system to select that portion of the reflected radiation which propagates roughly vertically, the system can be made very focusing insensitive.

In addition to or instead of spectral sensing devices, electromagnetic sensing devices may be employed at a metal-detection station. By means of an antenna extending across the advancing means, an alternating electromagnetic field can be set up across the advancing means. By providing as many eddy current detection points (in the form of individual detection coils) across the advancing means as there are spectral detection points a simultaneous metal

detection can be performed at very low additional cost.

Thereby, with a waste stream including polymer-coated beverage cartons, and with several air jet arrays arranged one after another it becomes possible to sort out:

- 5           beverage cartons without an aluminium barrier  
          beverage cartons with an aluminium barrier  
          other metal-containing objects.

With a more elaborate spectral analysis it also becomes possible to identify and sort out the type of polymer in a  
10 plastics object. The system could hence be applied to sorting into separate fractions the various plastics types occurring.

An important cost factor in the spectral analysis system, whether mirror systems or fibre optic systems are  
15 used, is the method chosen to "serve" the detection points.

According to a third aspect of the present invention, there is provided a method of automatically inspecting matter for varying composition, comprising advancing a stream of said matter through a detection station,  
20 irradiating with electromagnetic radiation comprising substantially invisible electromagnetic radiation a section of said stream at said station, scanning said section and determining the intensity of substantially invisible electromagnetic radiation of selected wavelength(s)  
25 reflected from portions of said stream, and obtaining detection data from said detection station, characterised in that said scanning is performed in respect of a plurality of discrete detection zones distributed across said stream and in that said determining is performed for each detection zone in respect of a plurality of said wavelengths  
30 simultaneously.

Owing to this aspect of the present invention, it is possible to increase the rate of reliable detection.

One device scanning all of the detection points should  
35 be the simplest and least expensive. A high-quality, high-speed device is required, but one optical separation unit with the required number of separation filters and detectors can then serve all detection points.

Frequency multiplexing IR pulses to all detection  
40 points is another alternative but this system would be more

sensitive to interference and more costly than the first alternative.

Time multiplexing, whether of IR pulses to all detection points or of analysis of the diffusely reflected IR, can be somewhat simpler than frequency multiplexing, but implies that spectral identifications in the various wavelengths should be done sequentially, which could pose practical problems and limitations.

Determination that post-consumer beverage cartons contain polyethylene-coated paperboard can advantageously be done with only a few IR wavelengths analysed. Only NIR wavelengths seem to be required to be analysed, for example:-

	<u>Wavelength (microns)</u>	<u>Filter Band Width (nm.)</u>
15	1. 1.565	85
	2. 1.662	34.5
	3. 1.737	32
	4. 1.855	79
	5. 2.028	114

Wavelength no. 5, 2.028 microns, is quite moisture-sensitive and may advantageously be omitted. This will leave a very low number of wavelengths to be analysed and compared, thus increasing the maximum computational speed of the system considerably compared to existing systems designed for elaborate polymer absorption characteristic comparison.

According to a fourth aspect of the present invention, there is provided a method of separating polymer-coated paperboard objects from a stream of waste, comprising advancing said stream through a detection station and separating the polymer-coated paperboard objects from the stream, characterised in that at said station a determination is made, using substantially invisible electromagnetic radiation, solely as to whether a portion of said waste is or is not a polymer-coated paperboard object.

Owing to this aspect of the invention, it is possible to minimize the number of radiation wavelengths required to

be analyzed.

Of the hereinbefore mentioned group of wavelengths Nos. 1 to 5, at least Nos. 2 and 3 are advantageously employed where IR radiation is utilized for separating-out of polyethylene-coated board, since, of common objects in a waste stream, paper and polymer-coated paperboard are the most difficult to distinguish between with IR detection and those two wavelengths give good discrimination between paper and polymer-coated paper.

According to a fifth aspect of the present invention, there is provided a method of automatically inspecting matter for varying composition, comprising advancing through a detection station a first stream of matter, and obtaining from said detection station first detection data as to a constituent of said first stream, characterised by advancing a second stream of matter through said detection station simultaneously with said first stream, and obtaining from said detection station second detection data as to a constituent of said second stream.

According to a sixth aspect of the present invention, there is provided apparatus for automatically inspecting matter for varying composition, comprising a detection station, first advancing means serving to advance through said station a first stream of matter, and detecting means serving to produce first detection data as to a constituent of said first stream at said station, characterised by second advancing means serving to advance a second stream of matter through said station simultaneously with said first stream, and said detecting means serving to produce second detection data as to a constituent of said first stream.

Owing to these aspects of the invention, whereby one-and-the-same detection station is employed for at least two streams simultaneously, the cost of inspection can be reduced compared with a case where the streams have respective detection stations.

The first and second streams can pass through the detection station in respective opposite directions or in a common direction. In the latter case, the streams can be conveyed on an upper run of an endless belt, with a partition along the upper run to keep the streams apart.

The streams can be inspected for respective constituents of differing compositions or of the same composition, in which latter case the second stream can be a separated-out fraction of the first stream, to produce a final separated-out fraction of increased homogeneity.

In order that the invention may be clearly understood and readily carried into effect, reference will now be made, by way of example, to the accompanying drawings, in which:-

Figure 1 illustrates diagrammatically a system for automatic sorting of waste objects of differing compositions, with detection from underneath,

Figure 2 illustrates diagrammatically a modified version of the system, with detection from above,

Figure 3 illustrates diagrammatically a variation of the version of Figure 2,

Figure 4 illustrates diagrammatically a beam-splitting detection unit of the modified version,

Figure 5 illustrates diagrammatically another modified version of the system in which detection is performed using three selected wavelengths of diffusely reflected IR,

Figure 6 is a graph of intensity against frequency for diffusely reflected IR and showing respective curves for a single layer of paperboard, a single layer of LDPE (low density polyethylene), and a laminate consisting of LDPE-coated paperboard,

Figure 7 is a graph similar to Figure 6 but showing sections of respective curves for the paperboard layer and the laminate and also respective reference transmission curves for three optical filters included in the system of Figure 5,

Figure 8 is a diagrammatic perspective view from above of a further modified version of the system, and

Figure 9 is a diagrammatic top plan view of a yet further modified version of the system,

Figure 10 is a diagrammatic side elevation of a still further modified version of the system, and

Figure 11 is a view similar to Figure 2, but of a system for monitoring and controlling the thickness of a polymer coating applied in a laminating machine.

Referring to Figure 1, at a detection station 131 there

are 24 detection points across and below a single-layer stream 1 of waste objects as it passes over a transverse slot 2 formed through a downwardly inclined plate 3 at the downstream end of a continuously advancing conveyor belt 4, with a separate IR source 5 for each detection point. At each detection point the reflected IR passes through a lens 6 focussed into an optical fibre 7 and these optical fibres 7 are terminated at a scanner 8, where an arm 9 of a material transparent to IR scans the 24 terminal points 10 of the optical fibres. The plastics arm 9 could be replaced by a mirror system or an IR-conducting fibre. The output 11 of the arm 9 is on the axis of the scanner 8, where a diffuser 12 shines the IR onto 6 infrared filters 13 which pass only respective individual IR wavelengths to IR detectors 14 dedicated to respective wavelengths and connected to an electronic control device 15. In this way each detector 14 serves 24 detection points. The scanning may be performed 100 times per second. If high irradiation intensity is needed, there would be high intensity, IR - producing, halogen lamps 5 at the respective detection points, in which case the focus depth would not be particularly critical. Downstream of the 24 detection points are one or more rows of air jet nozzles 16 to eject laminated objects, for example polymer-coated paperboard cartons, from the stream 1 and controlled by the outputs from the 24 detection points through the device 15. There can additionally be arranged across the stream a row of individual eddy current detectors the signals from which are used to operate one or more further rows of air jet nozzles which are spaced equivalently from the first mentioned row(s) of air jet nozzles as the eddy current detectors are spaced from the spectral detectors and which eject metal objects.

In an alternative form of scanner, the 24 optical fibres terminate at a single fixed disc, mounted opposite to which is a rotating disc carrying 6 (or 12) IR filters passing six wavelengths. Beyond the rotating disc is a ring of 24 detectors. The rotating disc is opaque to IR and the IR passes through that disc only at the locations of the filters. However, since all 6 filters must pass the

terminal of one of the optical fibres before a small carton  
can pass the corresponding detection point, the opaque disc  
must rotate at a very high speed, at something like  
30,000rpm. Moreover 24 detectors are required compared to  
5 the above-mentioned 6.

In an alternative embodiment, a single source of IR  
illuminates a chopper wheel which effectively emits six  
streams of IR radiation of a pulsed form, each stream being  
of a different pulse frequency. These IR streams are then  
10 fed by optical fibres to the detection points and the  
reflections at those detection points are then electrically  
detected and fed to a single electric processor. However, a  
disadvantage of this embodiment is that the conversion of  
the IR into pulsed IR means that the light intensity at the  
15 detection points is relatively much reduced and as a  
consequence the focal depth is relatively critical. It  
also requires a relatively very fast digital processing  
system to separate all of the frequencies and produce  
control outputs where required.

Referring to Figure 2, in this version IR sources 105  
are arranged in a horizontal arc across and above the  
horizontal conveyor belt 4. For some and perhaps all  
wavelengths in the infrared spectrum to be analysed, it is  
very desirable to avoid the forwarding towards the IR  
25 detectors (referenced 114 in Figure 4) of directly reflected  
IR. Diffusely reflected IR shows the best and most clearly  
defined absorption characteristics, which form the basis for  
determining the materials and laminate identity of the waste  
objects. This means that the IR sources 105 are mounted at  
30 low angles with respect to the conveyor belt 4 and the  
object surfaces to be identified, in order to reduce chances  
for direct IR reflection. It is also expected to be  
advantageous to mount the light sources 105 in such a way  
that each detection point is illuminated by more than one of  
35 the sources 105, to minimise shadows and to minimise the  
sensitivity of the system to the orientation of the object  
surfaces to be inspected.

An IR transmission system 107, 108 is based on metallic  
mirrors. By using a reflector 107 in the form of roughly a  
40 conical segment, with roughly a vertical cone axis, it is

possible to select that portion of the reflected IR from the objects on the conveyor belt which propagates in roughly a vertical direction, thereby making the system very focusing insensitive. This is because, if the only IR which is  
5 detected is roughly vertical, then variations in the heights of objects does not produce false readings caused by hiding of short objects by tall ones or by misrepresentation of the actual positions of objects. Height variations of the objects of up to 20cm can be tolerated, provided that the  
10 objects are sufficiently well irradiated.

By using a reflector 107 in the form of a doubly-curved surface of the shape of part of a torus an extra focussing effect of the IR reflected from a given detection point towards an optical separation/detection unit 120 can be  
15 obtained. This will allow more of the reflected IR from a given detection point to be focussed onto the unit 120 than that which propagates in a strictly vertical direction. Thereby, a significant intensity increase can be obtained compared to use of planar or conical reflectors.

20 By using a rotating polygonal (in this case hexagonal) mirror 108 in front of the optical separation/detection unit 120, it becomes possible to scan an almost arbitrarily chosen number of detection points per scan. The arbitrary choice is possible because the unit 120 is adjustable to  
25 sample at chosen, regular intervals. Six times per revolution of the mirror 108, a scan of the width of the conveyor belt is made. With the reflector 107, the "scan line" 121 on the conveyor belt is a circular arc. With a differently shaped reflector, the scan line can be straight.  
30 For example, instead of the reflector 107 of roughly conical segment form, it is possible to use a series of individual planar or doubly-curved mirrors appropriately angled to converge the IR towards the mirror 108. This reduces the data processing capacity required compared with the version  
35 shown in the Figure, because the distances from the detection points to the air jets 116 at the end of the belt 104 are then equal to each other. Using a hexagonal mirror reduces the necessary rotational speed of the mirror to one-third of a "front and back" 2-mirror configuration. The  
40 reflector system 107,108 has low losses and it is possible

to operate at high intensity and signal levels. This makes the material/object identification less susceptible to noise in the form of, for instance, stray light and internally generated noise in the opto-electronic systems.

5 As shown in Figure 4, the unit 120 comprises transparent plates 122 obliquely angled to the reflected IR beam 123 to split it into six beams 124 shone onto "positive" optical filters 113 of the detectors 114.

10 By applying a beam splitter and optical filter combination for each wavelength to be analysed, all selected wavelengths can be analysed simultaneously referring to the same spot on the object surface.

15 As an alternative to the beam splitter and filter combination 122 and 113, "negative" optical filters in the form of selectively reflecting surfaces can be employed. Such a negative filter mounted at an oblique angle will transmit nearly all light outside a particular wavelength, and the latter would be reflected to the appropriate detector. All detectors can then operate at much higher  
20 signal levels than when a beam splitter and "positive" filters are used.

In slowly operating sorting installations, it is conceivable that the IR wavelengths can be scanned sequentially, so that there is no need to split the  
25 reflected IR beam. An error source will occur in that the various wavelengths are not referred to exactly the same spot, but this may be acceptable when the conveyor belt is moving at low speed. By chopping the reflected IR 25 to 50 times per scan by utilising the motion of the polygonal  
30 mirror 108, a series of filters can be scanned for each detection location, and by an internal reflector in the optical detection unit all signals can be led to the same detector. This can also be achieved by having the filters mounted in a rotating wheel in front of the detector. The  
35 advantage of these solutions is that all detections are made with the same detector, avoiding sensitivity and response differences developing over time in a set of several detectors. Cost savings may also be realised.

40 The air jet ejection system for the selected waste objects may be a solenoid-operated nozzle array, indicated

as 116 in Figure 2. Normally each nozzle in this array is controlled in dependence upon the signal from an individual detection point, and the ejection is done by changing the elevation angle of the object trajectory when leaving the conveyor belt. For example, Figure 2 shows polymer-coated cartons 125 being selected for ejection into a bin 126. As an alternative and as shown in Figure 3, the nozzle array 116 may be mounted inside a slim profile 127 riding on or suspended just above the surface of the belt 104, so that unwanted objects can pass the ejection station without hindrance. Beverage cartons 125 are lifted from the profile and onto a second conveyor 128 by the nozzles 116. Alternatively, once lifted by the nozzles 116, they may be hit with a second air impulse, for example a transverse air flow, which could be triggered by a photocell rather than be continuous, to make them land in a bin at the side of the conveyor belt 104. This "two step" air ejection can also be advantageous when the nozzle array 116 is mounted at the end of the conveyor belt. The profile 127 has some means 129 for conveying the waste objects over its upper surface. Normally, the profile 127 is mounted upon a framework 132 also carrying the detection system 107, 108, 120.

In high-speed conveying systems, the belt 104 may have a speed in excess of 2 m/sec. The objects will then have a sufficient speed in leaving the belt at the end that only a weak air impulse, which might even be an air cushion, is required to change the trajectory. Possibly all detection points can be made to trigger such a weak air impulse allowing a very simple logic for the nozzle control, because there would be no need to calculate the centre of gravity of the object.

The analogue signals from the detector 120 are fed to an analogue-to-digital converter and data processor 135 the output from which is supplied to a controller 136 for solenoid valves (not shown) which control the supply of compressed air to the respective nozzles of the array 116.

Instead of or in addition to the IR-detection arrangement 105, 107, 108, 120, there may be employed, at the same detection station 131 or a second detection station 131, a metal-detection arrangement also illustrated in

Figure 2. The latter arrangement comprises an electrical oscillator 137 supplying an antenna 138 extending across substantially the whole width of the belt 104. The antenna 138 generates an oscillating electromagnetic field through the belt 104 which is detected by a row of a multiplicity of sensing coils 139 extending underneath the upper run of the belt 104 across substantially the whole width of the belt. The electrical outputs from the coils 139 are fed to a coil induction analyser, the output from which is fed to the converter/processor 135 and is utilised in controlling the supplies of compressed air to the nozzles 116.

Referring to Figure 5, in this preferred version waste objects are fed down a slide 145 (which helps to promote a single layer of waste objects on the conveyor 104) onto the horizontal conveyor 104. Arrays of halogen lamps 105 extend across the belt 104 at respective opposite sides of the detection station and are directed onto that transverse section of the belt at the station and so illuminate objects thereon from both upstream and downstream to reduce shading of objects from the light emitted by the lamps 105. The diffusely reflected light from the objects is reflected by the mirror 107 (or equivalent folding mirrors) onto the polygonal mirror 108, which is rotatable about a vertical axis, and thence to two beam splitters 122. The three sub-beams produced by the two splitters 122 pass to three positive optical filters 113, whence the IR beams of three respective predetermined wavelengths pass through respective lenses 146 to three detectors 114. The detectors 114 are connected via respective amplifiers 147 to an analogue-to-digital converter 135A the output from which is fed to a data processing module 135B. The module 135B is connected to both a user interface 148 in the form of a keyboard/display module and to a driver circuit 136 for solenoid valves of the respective nozzles of the array 116. A tachometer 149 at the output end of the conveyor 104 supplies to the module 135B data as to the speed of the belt 104. The nozzles eject the cartons 125 from the stream to beyond a dividing wall 150.

Figure 6 illustrates in full line, dotted line and dashed line, respectively, the curves (i), (ii) and (iii) of

typical diffusely reflected IR spectra for paperboard, LDPE, and LDPE-coated paperboard, respectively. In Figure 7, the three dotted lines (iv) to (vi) show the curves of the transmission bands of the three filters 113 in Figure 5. Particularly the band (vi) centred on 1730nm. and, to a lesser degree, the band centred on 1660nm. are optimisations for segregation between paper and paperboard, on the one hand, and LDPE-coated paperboard, on the other hand. The band (iv) centred on 1550nm. serves to distinguish LDPE-coated paperboard from certain other materials, e.g. nylon and some plastics with much colour pigment. The curves (i) to (iii) in Figures 6 and 7 have been normalised such that the average value of the intensity over the wavelength range is 1.0.

Referring to Figure 8, this version has the horizontal upper run of its belt 104 divided into two lanes by a longitudinal partition 160. The detection station(s) 131 again contain the light-receiving means (7;107) and/or the electromagnetic-field generating means (138) and its associated field-variation detecting means (139) and this/these again extend(s) across substantially the whole width of the belt 104. The nozzle array 116 again extends across substantially the whole width of the belt 104. A stream of waste including objects, for example laminate cartons, to be separated-out is advanced, as a single layer of waste, along the lane indicated by the arrow 161, the objects to be separated-out are detected in any manner hereinbefore described with reference to the drawings, and are ejected into a hopper 162 with the aid of air jets from nozzles of the array 116, most of the remaining waste falling onto a transverse conveyor belt 163 for disposal. The stream fraction discharged into the hopper 162 tends to contain a proportion of waste additional to the objects to be separated-out and is therefore discharged from the hopper 162 onto an upwardly inclined, return conveyor belt 164 which lifts the fraction onto a slide 165 whereby the fraction slips down onto the lane indicated by the arrow 166. The belt 104 then advances the fraction along the lane 166 past the detection station(s) 131, while it simultaneously advances the stream along the lane 161 past

the same detection station(s), and subsequently the objects to be separated-out are ejected from the fraction with the aid of air jets from other nozzles of the array 116 into a hopper 167 whence they are discharged into a bin 168. Other waste from the fraction falls onto the conveyor 163 for disposal.

Figure 9 shows a modification of Figure 8, in which two parallel, horizontal conveyor belts 104A and 104B disposed side-by-side advance in respective opposite directions through a detection station or stations 131, the light-receiving mirror(s) and/or the antenna and the row of sensing coils of which extend(s) across substantially the whole overall width of the two belts 104A and 104B. A stream of waste containing the waste objects to be separated-out is advanced by the conveyor 104A past the detection station(s) 131 where those objects are detected, to an air nozzle array 116A whereby a stream fraction consisting mainly of the objects to be separated-out is ejected into a hopper 162, discharged onto a conveyor 164 and lifted onto a slide 165, whence the fraction slips down onto the belt 104B. The remainder of the stream falls onto a transverse conveyor 163A. The belt 104B advances the fraction past the detection station(s) 131, where those objects are again detected, to an air nozzle array 116B with the aid of which the desired objects are ejected into the hopper 167, remaining waste in the fraction falling onto a transverse conveyor 163B.

The two lanes 161 and 166 or the two conveyors 104A and 104B could advance respective streams from which respective differing types of material (for example laminated material and purely plastics material, or, as another example, laminated material and wood-fibre material or metallic material) are to be separated-out. In that case, the conveyor 164 would be omitted, the hopper 162 would discharge into a bin a stream fraction comprised of the material separated-out into the hopper 162 and the remainder of the stream advanced by the lane 161 or conveyor 104A would be forwarded by the conveyor 163A to the slide 165 to constitute the stream on the lane 166 or conveyor 104B, and the hopper 167 would discharge into a bin a second stream

fraction comprised of the other material to be separated-out.

5 The various embodiments utilising detection by radiation and described with reference to Figures 1 to 5, 8 and 9 are applicable in the waste recovery field also to sorting of a mixture of plastics wastes in fractions each predominantly of one type of plastics, and also applicable to a variety of other fields in which matter of varying composition is to be sorted. For example, they are applicable in the food industry for separating-out from 10 animal solids, namely meat and fish, discrete portions, for example whole chickens or salmon or pieces of chicken, salmon, or beef, which are below quality thresholds. As instances, detection of diffusely reflected IR can be used to monitor for excessive amounts of fat, whilst detection of 15 diffusely reflected visible light can be used to determine the colour of the portions and so monitor for staleness, for example. Because a plurality of discrete portions can advance side-by-side in the stream, high capacity monitoring can be achieved, with or without the use of air jets to 20 eject the relevant fraction from the stream.

Referring to Figure 10, this version includes an eddy current ejection system for ejecting electrically conductive metal from a stream of waste and known per se. The eddy 25 current system has, within a discharge end roller 170 of the belt conveyor 104, permanent magnets 170a contained within and distributed along the roller 170 and counter-rotating relative to the roller 170. To separate-out polymer-coated paperboard cartons without metal foil and to improve the separation-out of polymer-coated paperboard cartons with 30 metal foil, the IR detection system of Figure 5 is also provided, as diagrammatically indicated in Figure 10, where the IR detection station 131, the two arrays of halogen lamps 105 and the air nozzle array 116 are shown. The belt 35 104 advances at relatively high speed, at least 2m./sec. At its discharge end are three compartments 171 to 173, respectively for remaining waste, separated-out metallic objects with greater metal contents and separated-out polymer-coated paperboard objects, usually cartons, whether 40 or not containing metal foil. The metallic objects with

greater metal contents, for example post-consumer beer cans, are nudged upwards out of the waste stream by the eddy current system, but, because they are generally heavier than the other objects, fall into the compartment 172 just beyond  
5 the general waste compartment 171. The polymer-coated paperboard objects, provided that a surface polymer coating directly onto the paperboard (and not, for example, a surface polymer coating directly onto aluminium foil) faces towards the mirror 107, are nudged upwards by the weak air  
10 jet pulses from the nozzle array 116, but to higher than the metallic objects with greater metal contents, and fall into the furthest compartment 173.

Advantages of this version are that it separates waste into three fractions in a single-stage operation and that an  
15 IR detection system can be fitted to an already installed eddy current ejection system, without any need to alter either system significantly.

Referring to Figure 11, in the laminating machine, a paperboard substrate 180 is advanced through an extrusion  
20 coating station 181 and is introduced into the nip between a pair of rollers 182. An extruder 183 extrudes a molten film 184 of polymer, for example LDPE, onto the upper surface of the substrate 180 at the nip. A winding roll  
25 185 advances past the detection station 131 the laminate web 186 so formed. As already explained hereinbefore, to measure the thickness of the polymer coating, two appropriately chosen wavelengths in the IR spectrum are monitored. This monitoring is performed in the  
30 converter/processor 135, which controls the extruder 183 accordingly. Instead of being of a part-toroidal form, the mirror 107 can comprise a series of facets 107a (or even a series of very small mirrors) arranged in a horizontal row transverse to the laminate 186 and arranged to reflect the  
35 diffusely reflected IR from the respective detection points (imaginarily indicated at 187) to the polygonal mirror 108. Each detection point 187 thus has an individual facet 107a dedicated to it. In this way, the mirror 107 can extend  
40 rectilinearly, rather than arcuately, across the web 186, as can the array of halogen lamps 105, with the advantage of reducing the necessary overall dimension of the detection

station 131 longitudinally of the web 186. Such rectilinearly extending mirror 107 is of course applicable in the versions of Figs. 2 to 5 and 8 to 10, with corresponding advantage.

CLAIMS

1. A method of automatically inspecting matter for varying composition, comprising advancing a stream of said matter through a detection station (131), emitting a detection medium to be active at a transverse section of said stream at said detection station (131), wherein said medium is varied by variations in the composition of said matter at said transverse section, receiving the varied medium at receiving means (7; 107; 139), and generating detection data in dependence upon the variations in said medium, characterised in that said varied medium is received over substantially the width of the stream by said receiving means (7; 107; 139) which physically extends across substantially the width of said stream.
2. A method according to claim 1, wherein said emitting occurs at a location significantly spaced from said receiving means (7; 107; 139).
3. A method according to claim 1 or 2, wherein said emitting occurs over substantially the width of said stream.
4. A method according to any preceding claim, wherein said transverse section comprises a multiplicity of individual detection zones distributed across substantially the width of said stream.
5. A method according to any preceding claim, wherein said detection medium comprises electromagnetic radiation which irradiates said section, said generating including determining the intensity of electromagnetic radiation of selected wavelength(s) reflected from portions (125) of said stream distributed across said stream.
6. A method according to claim 5, wherein said portions (125) comprise polymer and said selected wavelengths comprise a plurality of wavelength bands in the region 1.5 microns to 1.85 microns.
7. A method according to claim 5 or 6, wherein said receiving means (7; 107; 139) receives from said stream diffusely reflected said electromagnetic radiation travelling substantially perpendicularly to a widthwise and lengthwise plane of said stream.
8. A method according to claim 5, 6, or 7, as appended to claim 4, wherein said determining is performed for each

detection zone in respect of a plurality of wavelengths simultaneously.

9. A method according to claim 5, 6 or 7, as appended to claim 4, wherein said electromagnet radiation is supplied as pulses to each detection zone in a frequency multiplexed manner.

10. A method according to claim 5, 6, or 7, as appended to claim 4, wherein said determining is performed for each detection zone in respect of a plurality of said wavelengths in a time multiplexed manner.

11. A method according to any one of claims 5 to 10, wherein portions of said stream are substantially transparent to said electromagnetic radiation and said stream is advanced on a supporting surface (4, 104) which is diffusely reflective of said electromagnetic radiation.

12. A method according to any one of claims 5 to 10, wherein said matter comprises laminate (125, 186) comprised of a first layer (184) and a second layer (180) underneath said first layer (184) and of a material having a spectrum of reflected said electromagnetic radiation significantly different from that of the material of the first layer (184).

13. A method according to claim 12, wherein said stream of matter is a continuous strip of laminate (186) advancing on a laminating machine and said detection data is utilised to control the laminating process performed on said machine.

14. A method according to claim 13, wherein said first layer (184) is a coating of a polymer and said second layer (180) is a substrate (180) and variation in the composition of said first layer (184) is detected at said detecting station (131) and said detection data is utilised to control the coating process in said machine.

15. A method according to claim 14, wherein said variation in composition is variation in thickness of said first layer.

16. A method according to any one of claims 1 to 12, and further comprising utilising said detection data to separate from said stream a stream fraction comprised of desired portions (125) of said stream.

17. A method according to claim 16, wherein said stream

comprises solid food.

18. A method according to claim 17, wherein said solid food comprises higher-quality discrete portions and lower-quality discrete portions and said detection data is utilised to  
5 separate the stream into a higher-quality fraction and a lower-quality fraction, one of which fractions is comprised of said desired portions (125).

19. A method according to claim 16 as appended to claim 12, wherein said stream fraction comprises said laminate (125)  
10 as said desired portions (125).

20. A method according to claim 19, wherein said stream of matter is a stream of waste including said laminate (125) in the form of polymer-coated paperboard objects (125) and said determining is solely as to whether a portion of said  
15 waste is or is not a polymer-coated paperboard object (125), said stream fraction being comprised of the polymer-coated paperboard objects (125) as said desired portions (125).

21. A method according to claim 20, wherein said polymer is polyethylene, said substrate is paperboard and one of said  
20 wavelengths is in a band centred on substantially 1.7 microns.

22. A method according to claim 16, 19, 20, or 21, as appended to claim 5, and further comprising separating from said stream by means of eddy current ejection a second  
25 fraction comprised of metal portions.

23. A method according to any one of claims 1 to 4, wherein said detection medium comprises an electromagnetic field which induces eddy currents in metal portions of said stream at said detection station.

30 24. A method according to claim 23, and further comprising utilising said detection data to separate from said stream a stream fraction comprised of said metal portions as said desired portions.

25. A method according to any one of claims 19 to 21, and  
35 further comprising advancing said stream through a metal-detection station (131) including a multiplicity of metal-detection zones distributed across said stream, inducing eddy currents in metal portions of said stream at said metal-detection station, producing electrical signals in  
40 dependence on said eddy currents, and utilizing said

detection data in the form of said electrical signals in separating from said stream a stream fraction comprised of said metal portions as other desired portions.

5 26. A method according to any one of claims 19 to 25, and further comprising simultaneously cycling through the method, including advancing through the detection station(s) (131), another stream of matter, and utilizing the detection data obtained from said other stream in separating therefrom another fraction comprised of further desired portions.

10 27. A method according to claim 26, wherein the first-mentioned stream and said other stream are advanced in a common direction through said detection station.

15 28. A method according to claim 26, wherein the first-mentioned stream and said other stream are advanced in respective opposite directions through said detection station.

20 29. A method according to any one of claims 16 to 28, wherein the separating comprises causing air jet pulses to impinge upon said desired portions to force the same out of the stream(s).

30. A method according to claim 29, wherein said advancing is relatively fast and said air jet pulses are relatively weak.

25 31. A method according to any one of claims 26 to 28, or claim 28 or 29 as appended to claim 25, wherein said other stream comprises the separated-out fraction(s) of the first-mentioned stream.

30 32. A method according to any one of claims 26 to 28, or claim 29 or 30 as appended to claim 26, wherein said other fraction consists predominantly of a material of a differing constituency from that of the separated-out fraction(s) of the first-mentioned stream.

35 33. Apparatus for automatically inspecting matter for varying composition, comprising advancing means (4; 104; 185) for advancing a stream of said matter, a detection station (131) through which said advancing means (4; 104; 185) advances said stream, emitting means (5; 105; 138) serving to emit a detection medium to be active at a transverse section of said stream at said station (131),  
40 receiving means (7; 107; 139) at said station (131) serving

- to receive detection medium varied by variations in the composition of said matter at said section and detecting means (14;114; 140) serving to generate detection data in dependence upon the variations in said medium, and data-obtaining means (15; 135) connected to said detecting means (14; 114; 140) and serving to obtain said detection data therefrom, characterised in that said receiving means (7; 107) is arranged to extend physically across substantially the width of said stream.
- 5
- 10 34. Apparatus according to claim 33, wherein said emitting means (5; 105; 138) is significantly spaced from said receiving means (7; 107; 139).
35. Apparatus according to claim 33 or 34, wherein said emitting means (5; 105; 138) is arranged to extend
- 15 physically across substantially the width of said stream.
36. Apparatus according to claim 33, 34, or 35, wherein said emitting means (5; 105) serves to emit electromagnetic radiation as said detection medium, said detecting means (14; 114; 140) serving to determine the intensity of
- 20 electromagnetic radiation of selected wavelength(s) reflected from portions (125) of said stream distributed across said stream.
37. Apparatus according to claim 36, wherein said emitting means (105) is arranged to irradiate said portions (125)
- 25 obliquely relative to a widthwise and lengthwise plane of said stream and said receiving means (107) is arranged to receive from said portions (125) diffusely reflected said electromagnetic radiation travelling substantially perpendicularly to that plane.
- 30 38. Apparatus according to claim 36 or 37, wherein said emitting means (5;105) comprises a multiplicity of sources (5;105) of said electromagnetic radiation arranged to be distributed across said stream.
39. Apparatus according to any one of claims 36 to 38,
- 35 wherein said advancing means (4, 104) has a stream-supporting surface which is diffusely reflective of said electromagnetic radiation.
- 40 40. Apparatus according to any one of claims 36 to 39 and included in a laminating machine, said data-obtaining means (135) serving to control the laminating process performed on

said machine.

41. Apparatus according to any one of claims 36 to 39 and further comprising, downstream of said detection station (131), separating means (116) serving to separate from said stream a fraction comprised of desired portions (125) of said stream selected in accordance with said detection data obtained.

42. Apparatus according to claim 41, and further comprising an eddy current ejection arrangement (170) serving to eject metal portions from said stream.

43. Apparatus according to claim 42, wherein said separating means (116) and said eddy current ejection arrangement (170) are disposed one immediately after the other along said advancing means (104).

44. Apparatus according to any one of claims 36 to 43, wherein said receiving means (7; 107) comprises reflecting means (7; 107).

45. Apparatus according to claim 44, wherein said reflecting means (107) comprises a mirror (107) which is substantially arcuate concavely in a plane parallel to the widthwise and lengthwise plane of said stream and which is obliquely inclined to the former plane.

46. Apparatus according to claim 45, wherein said mirror (107) is part of an imaginary, substantially toroidal surface.

47. Apparatus according to claim 44, wherein said reflecting means (107) comprises a multiplicity of reflectors (107a) distributed in a row arranged to extend substantially rectilinearly across said stream, said reflectors (107a) being differingingly orientated so as to transmit electromagnetic radiation reflected from a multiplicity of detection zones distributed across said stream at said transverse section.

48. Apparatus according to any one of claims 36 to 47, and further comprising a polygonal mirror (108) interposed between said receiving means (107) and said detecting means (114) and having its reflective faces arranged around an axis of rotation of said polygonal mirror (108).

49. Apparatus according to any one of claims 36 to 43, wherein said receiving means (7) comprises conducting means

(7) for conducting therealong said electromagnetic radiation.

50. Apparatus according to claim 49, wherein said conducting means (7) comprises a multiplicity of optical fibres (7) having their entrances arranged to be distributed across said stream.

51. Apparatus according to any one of claims 36 to 50, and further comprising beam splitting means (122) interposed between said receiving means (107) and said detecting means (114) for said electromagnetic radiation.

52. Apparatus according to any one of claims 33 to 35, wherein said station (131) is a metal-detection station and said emitting means (138) serves to emit an electromagnetic field, said receiving means (139) comprising a multiplicity of electromagnetic field sensing devices (139) arranged to be distributed across said stream.

53. Apparatus according to any one of claims 36 to 51, and further comprising a metal-detection station (131) past which said advancing means (104) advances said stream, another emitting means (138) serving to generate an electromagnetic field, and another receiving means (139) arranged so as to be discretely distributed across said stream at said metal-detection station (131) and serving to detect metal portions of said stream advancing past said metal-detection station (131), and metal-separating means (116) downstream of said metal-detecting means (139) and serving to separate from said stream a fraction comprised of said metal portions.

54. Apparatus according to claim 52 or 53, wherein said emitting means (138) which serves to generate an electromagnetic field comprises an antenna (138) extending across said advancing means (104) at said metal-detection station (131), said advancing means (104) being situated between said antenna (138) and said receiving means (139) for the field.

55. Apparatus according to claim 41, 42, or 43, or any one of claims 44 to 54 as appended to claim 41, wherein said advancing means (104) comprises a substantially planar conveying surface and said separating means (116) is carried by an auxiliary conveying means (127) positionable at said

conveying surface to lift said stream from said conveying surface and forward said stream to said separating means (116).

5 56. Apparatus according to any one of claims 33 to 55, and further comprising second advancing means (104) serving to advance another stream of matter through the detection station(s) (131), said receiving means (7;107;139) serving also to receive detection medium varied by variations in the composition of the matter of said other stream at a  
10 transverse section of said other stream, said detecting means (14,114;140) serving also to generate detection data in dependence upon the latter variations in said medium, said data-obtaining means (15,135) serving also to obtain said detection data in respect of said other stream.

15 57. Apparatus according to claim 56, wherein said second advancing means (104) is arranged to advance said other stream through the detection station(s) 131 in substantially the same direction as that in which the first-mentioned advancing means (104) is arranged to advance the first-  
20 mentioned stream through the detection station(s) (131).

58. Apparatus according to claim 57, wherein said first-mentioned advancing means (104) and said second advancing means (104) take the form of a single conveyor (104).

25 59. Apparatus according to claim 58, wherein said single conveyor (104) includes a single conveying belt (104).

60. Apparatus according to claim 58 or 59, wherein said single conveyor (104) has a portion (160) extending therealong to keep the streams apart from each other.

30 61. Apparatus according to claim 57, wherein said second advancing means (104B) is arranged to advance said other stream through the detection station(s) 131 in substantially the opposite direction to that in which the first-mentioned advancing means (104A) is arranged to advance the first-mentioned stream through the detection station(s) (131).

35 62. Apparatus according to any one of claims 56 to 61 as appended to claim 41, and further comprising returning means (164) serving to transport the separated-out fraction(s) of the first-mentioned stream to said second advancing means (104B) upstream of said detection station(s) (131) to  
40 constitute said other stream.

63. Apparatus according to any one of claims 56 to 62, wherein said separating means (116) serves also to separate another fraction from said other stream.

5 64. Apparatus according to claim 41, 42, 43, 53, or 63, wherein the separating means (116) comprises one or more rows of air jet nozzles (116) arranged transversely of the advancing means (104).

65. A method of automatically inspecting matter for varying composition, comprising advancing a stream of said matter  
10 through a detection station (131), irradiating with electromagnetic radiation comprising substantially invisible electromagnetic radiation a section of said stream at said station (131), scanning said section and determining the intensity of substantially invisible electromagnetic  
15 radiation of selected wavelength(s) reflected from portions of said stream, and obtaining detection data from said detection station (131), characterised in that said scanning is performed in respect of a plurality of discrete detection zones distributed across said stream and in that said  
20 determining is performed for each detection zone in respect of a plurality of said wavelengths simultaneously.

66. A method according to claim 65, wherein portions of said stream comprise polymer and said plurality of wavelengths comprise a plurality of wavelength bands in the  
25 region 1.5 microns to 1.85 microns.

67. A method of separating polymer-coated paperboard objects from a stream of waste, comprising advancing said stream through a detection station (131) and separating the polymer-coated paperboard objects (125) from the stream,  
30 characterised in that at said station (131) a determination is made, using substantially invisible electromagnetic radiation, solely as to whether a portion of said waste is or is not a polymer-coated paperboard object (125).

68. A method of automatically inspecting matter for varying composition, comprising advancing through a detection  
35 station (131) a first stream of matter, obtaining from said detection station (131) first detection data as to a constituent of said first stream, characterised by advancing a second stream of matter through said detection station  
40 (131) simultaneously with said first stream, and obtaining

from said detection station (131) second detection data as to a constituent of said second stream.

69. A method according to claim 68, wherein the first and second streams are advanced in a common direction through said detection station (131).

70. A method according to claim 68, wherein the first and second streams are advanced in respective opposite directions through said detection station (131).

71. A method according to any one of claims 68 to 70, and further comprising utilising the first and second detection data to separate from the respective first and second streams respective first and second fractions comprised of said constituent of said first stream and said constituent of said second stream, respectively.

72. A method according to claim 71, wherein the first fraction constitutes the second stream.

73. A method according to any one of claims 68 to 72, wherein said constituent of said first stream is of substantially the same composition as said constituent of said second stream.

74. A method according to any one of claims 68 to 72, wherein said constituent of said first stream is of a significantly different composition from said constituent of said second stream.

75. Apparatus for automatically inspecting matter for varying composition, comprising a detection station (131), first advancing means (104) serving to advance through said station (131) a first stream of matter, and detecting means (4; 114; 140) serving to produce first detection data as to a constituent of said first stream at said station (131), characterised by second advancing means (104) serving to advance a second stream of matter through said station (131) simultaneously with said first stream, and said detecting means (4; 114; 140) serving to produce second detection data as to a constituent of said first stream.

76. Apparatus according to claim 75, wherein the first and second advancing means (104) are arranged to advance the first and second streams through said detection station (131) in a common direction.

77. Apparatus according to claim 76, wherein the first and

second advancing means (104) take the form of a single conveyor (104).

78. Apparatus according to claim 77, wherein said single conveyor (104) includes a single conveying belt (104).

5 79. Apparatus according to claim 77 or 78, wherein said single conveyor (104) has a partition (160) extending therealong to keep the streams apart from each other.

80. Apparatus according to claim 75, wherein the first and second advancing means (104A, 104B) are arranged to advance  
10 the first and second streams in respective opposite directions through said detection station (131).

81. Apparatus according to any one of claims 75 to 79, and further comprising returning means (164) serving to transport to said second advancing means (104) upstream of  
15 said station (131) to constitute said second stream a separated-out fraction of said first stream comprised of said constituent of said first stream.

82. Apparatus according to any one of claims 75 to 81 and further comprising radiation-emitting means (5; 105) serving  
20 to emit radiation to irradiate respective, substantially aligned, transverse sections of the first and second streams, and radiation receiving means (7; 107) at said station (131) serving to receive radiation reflected from said sections and to communicate the same to said detecting  
25 means (4; 114).

83. Apparatus according to claim 82, wherein said radiation emitting means (5; 105) is so arranged as to extend across both of the first and second streams.

84. Apparatus according to claim 83, wherein said radiation emitting means (5;105) comprises a row of radiation sources  
30 (5;105).

85. Apparatus according to any one of claims 82 to 84, wherein said receiving means (7;107) is so arranged as to extend across both of the first and second streams.

86. Apparatus according to claim 85, wherein said receiving  
35 means (107) comprises radiation-reflecting means (107).

87. Apparatus according to claim 86, wherein said reflecting means (107) comprises a mirror (107) which is substantially arcuate concavely in a plane parallel to a  
40 widthwise plane of the first and second streams and which is

obliquely inclined to the former plane.

88. Apparatus according to claim 87, wherein said mirror (107) is part of an imaginary, substantially toroidal surface.

5 89. Apparatus according to any one of claims 75 to 81, wherein said detecting means (140) communicates with a multiplicity of metal-sensing means (139) arranged so as to be discretely distributed across the first and second  
10 streams and serving to detect metal portions constituting the constituent(s) of at least one of the first and second streams.

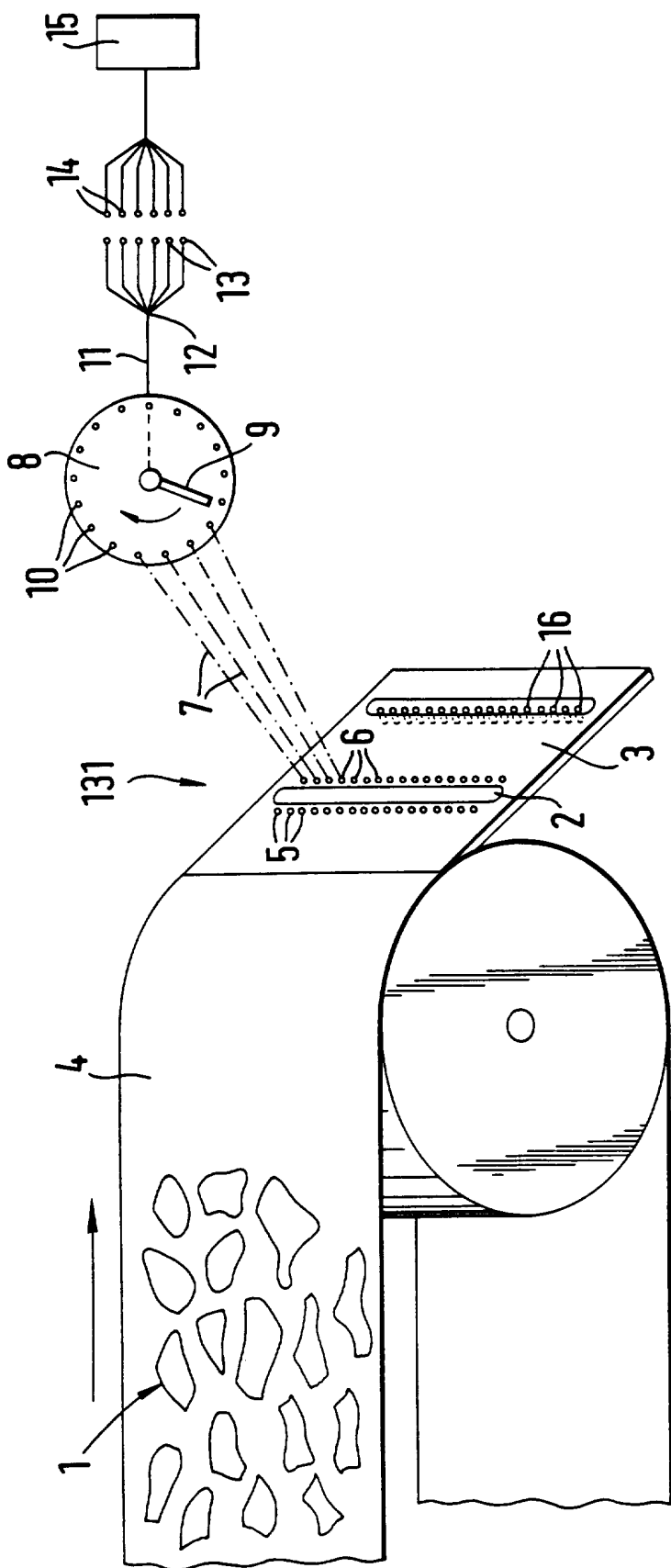

Fig.1

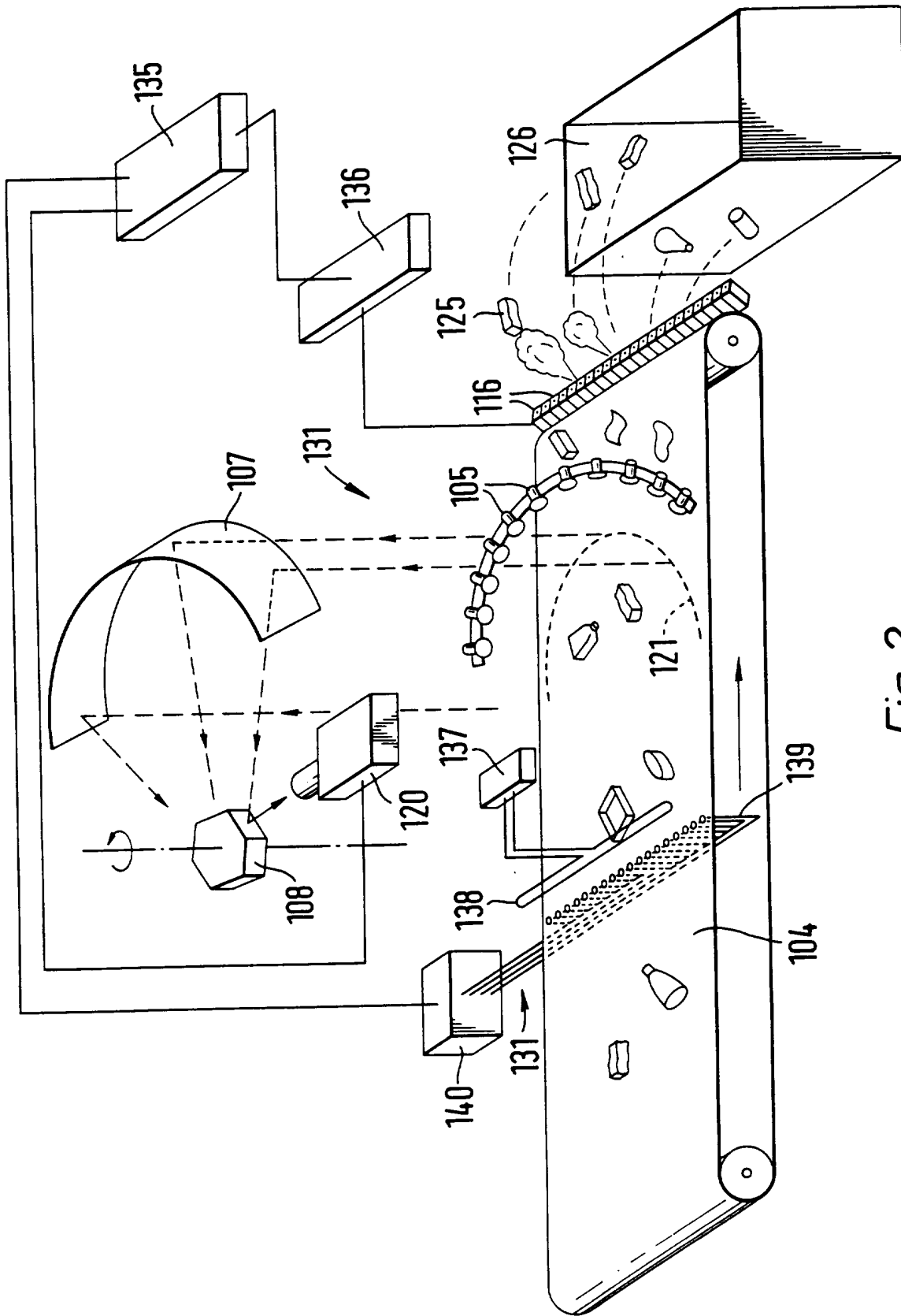

Fig. 2



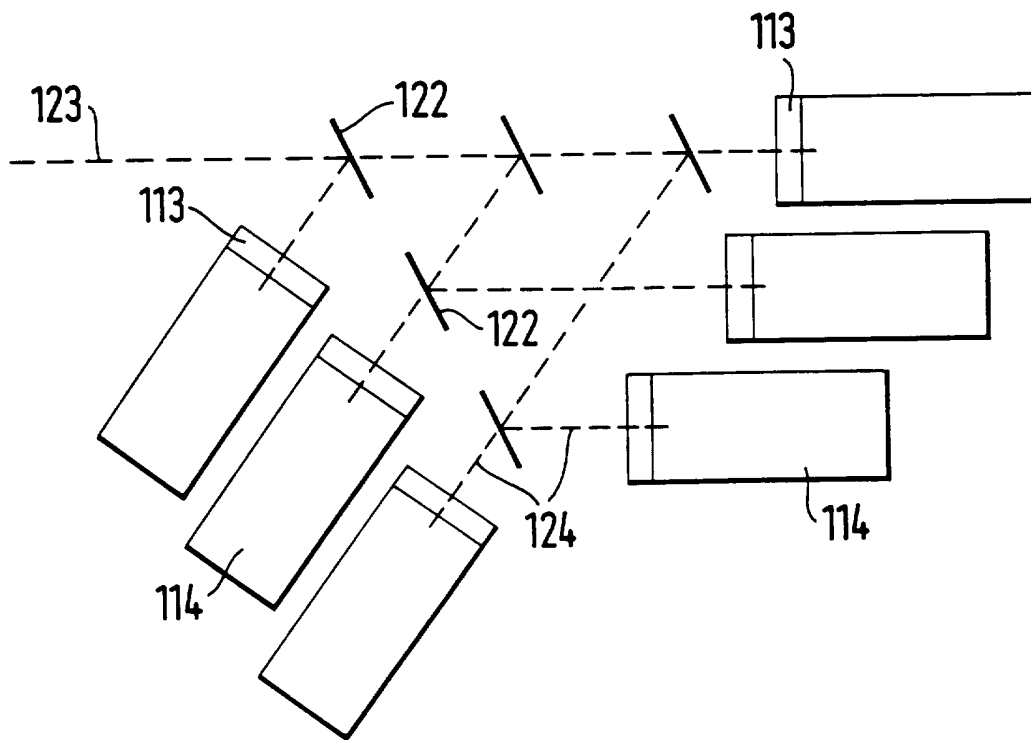

Fig. 4



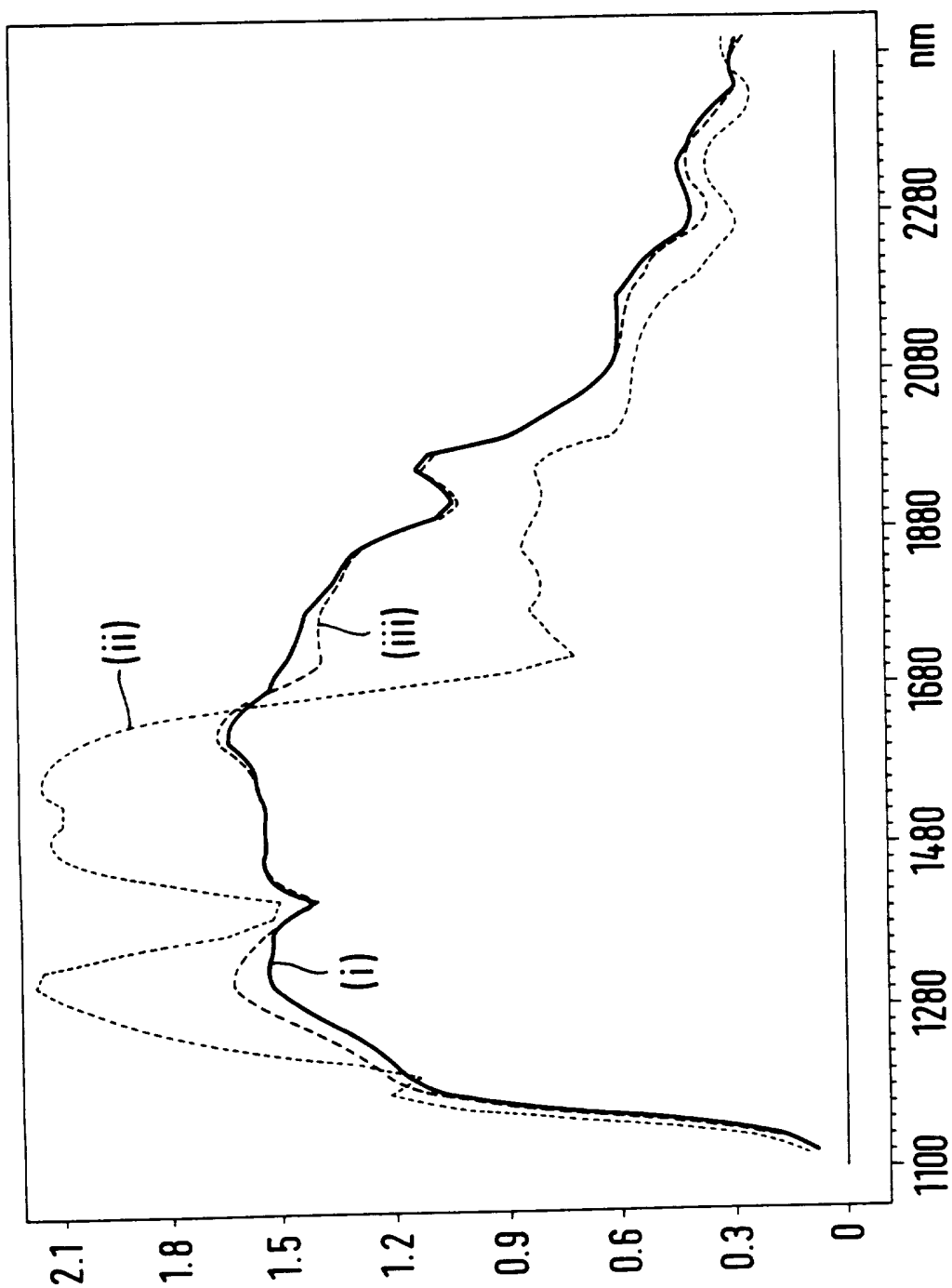

Fig. 6

7/10

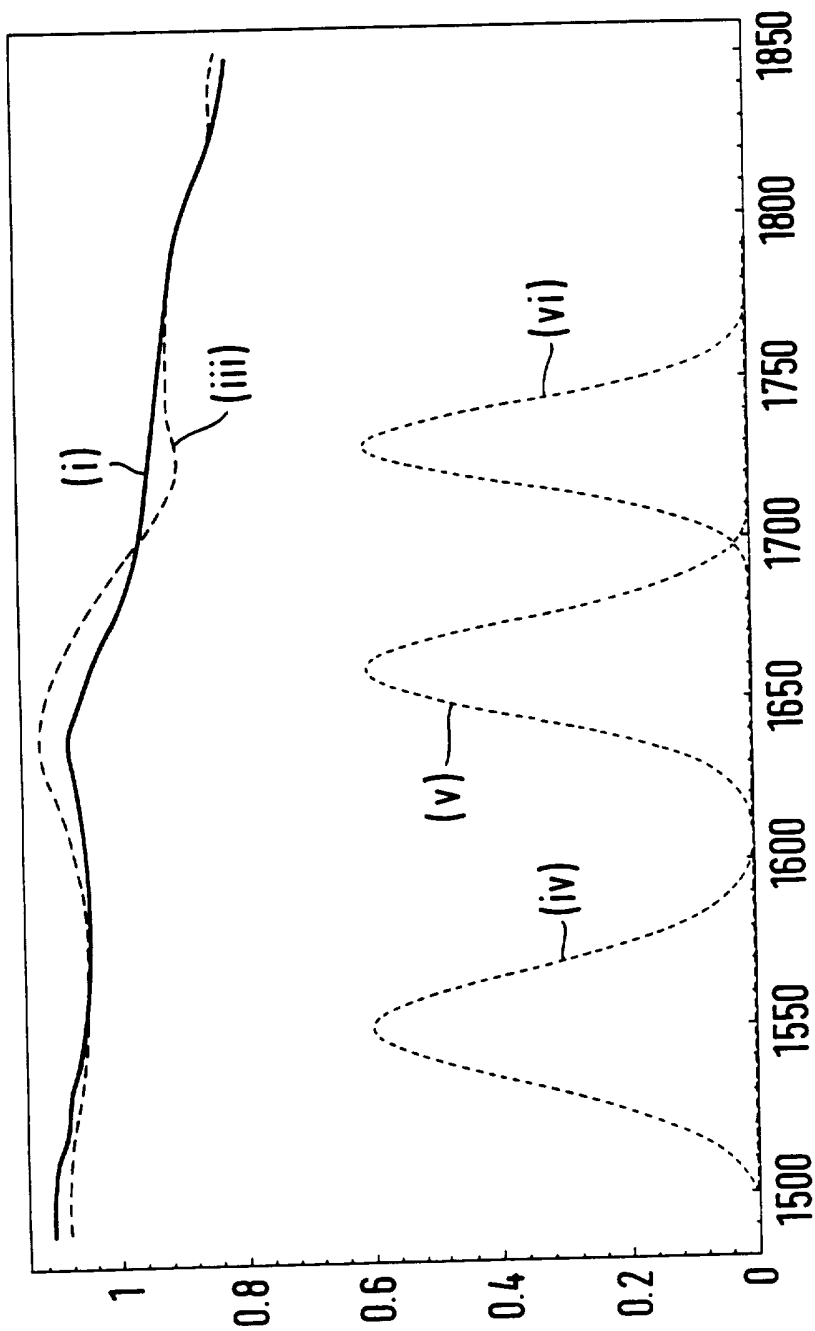

Fig. 7

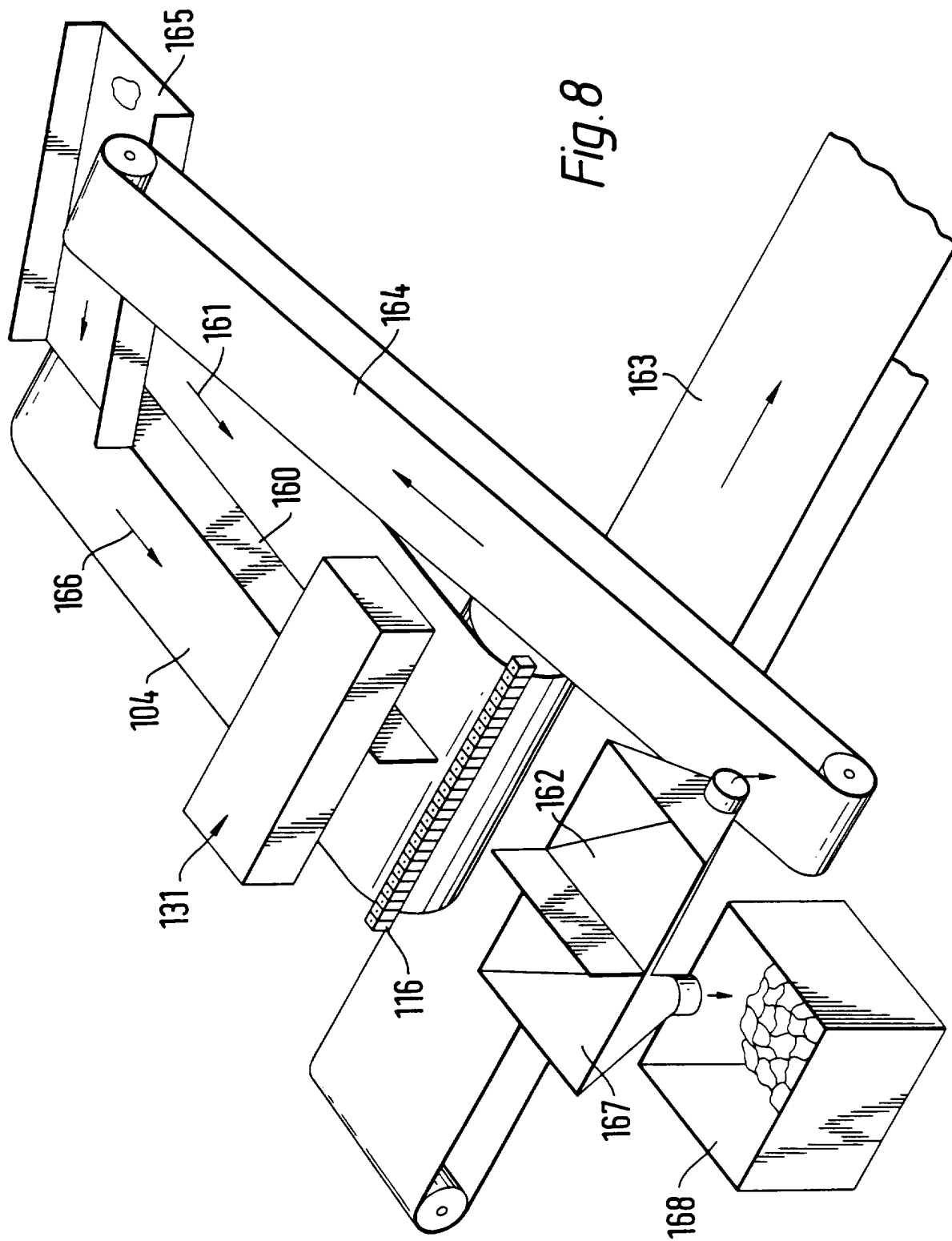

Fig. 8

9/10

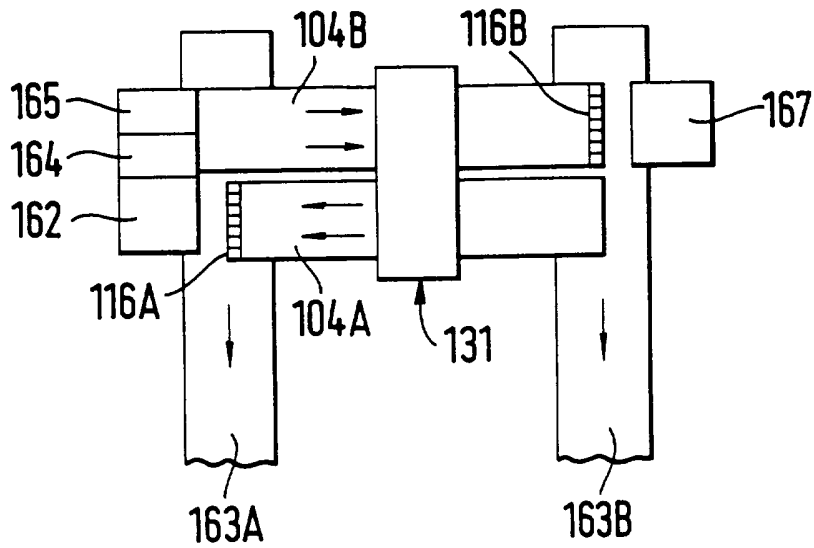

Fig. 9

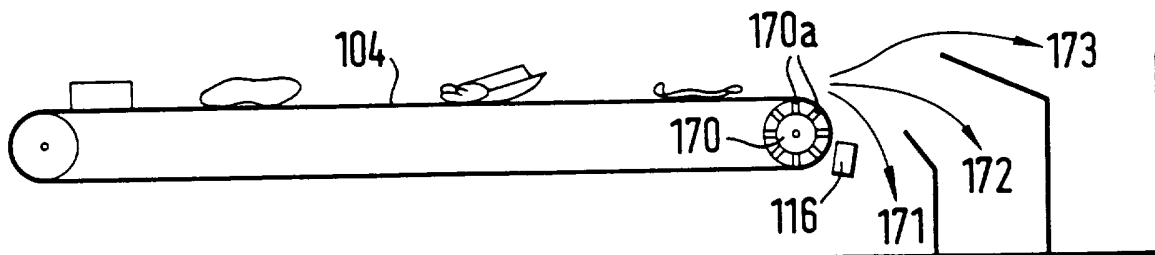
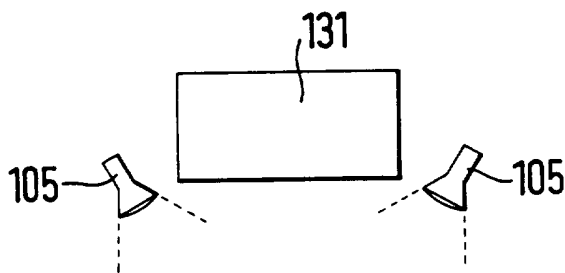

Fig. 10

10/10

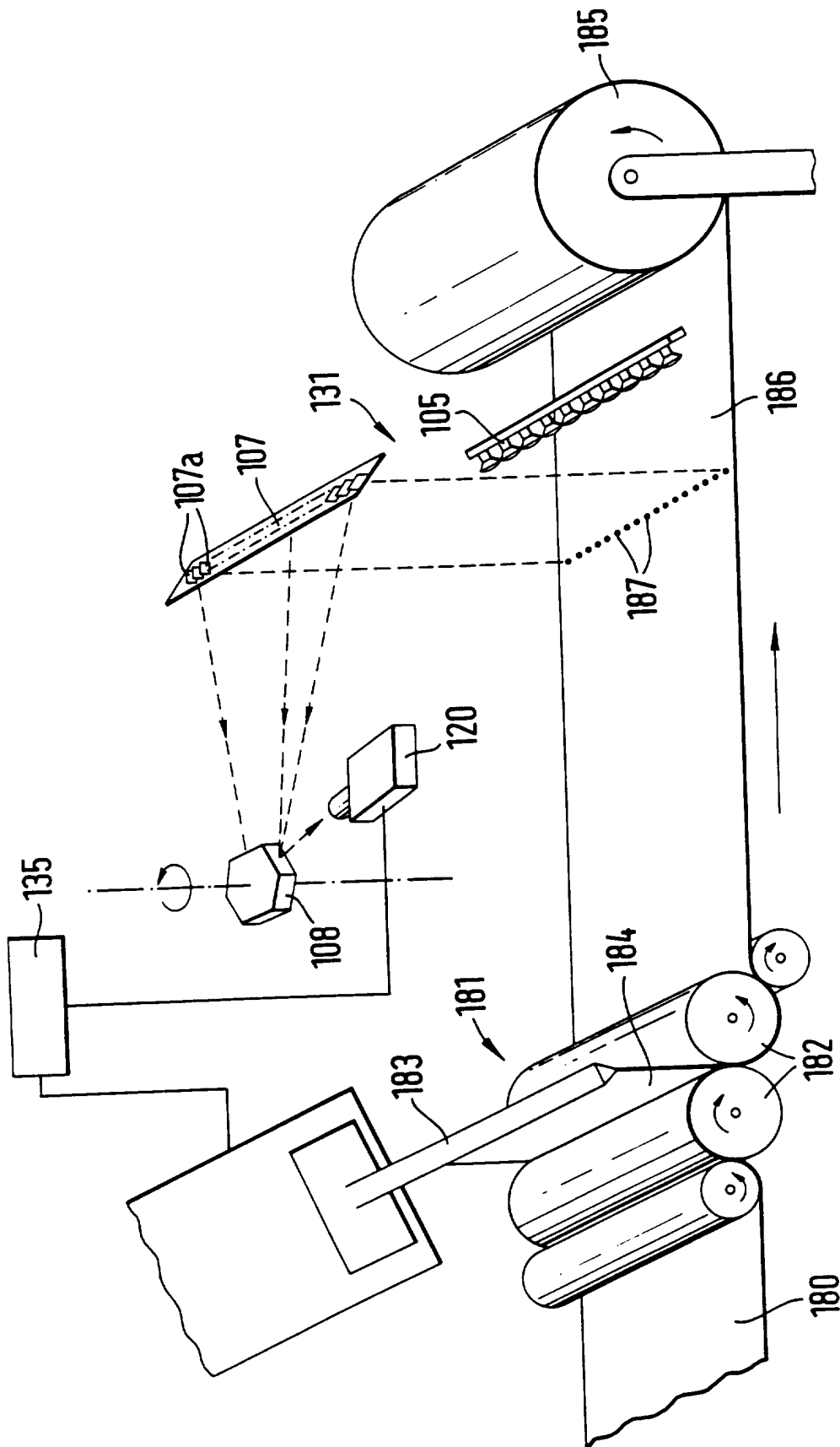

Fig.11