



US 20250221464A1

(19) **United States**

(12) **Patent Application Publication**  
**CHATEAU et al.**

(10) **Pub. No.: US 2025/0221464 A1**

(43) **Pub. Date: Jul. 10, 2025**

(54) **AN AEROSOL-GENERATING DEVICE AND SYSTEM AND METHOD FOR CONTROL THEREOF**

*A24F 40/20* (2020.01)  
*A24F 40/465* (2020.01)  
*A24F 40/51* (2020.01)  
*A24F 40/53* (2020.01)

(71) Applicant: **Philip Morris Products S.A.**,  
Neuchatel (CH)

(52) **U.S. Cl.**  
CPC ..... *A24F 40/57* (2020.01); *A24F 40/10* (2020.01); *A24F 40/20* (2020.01); *A24F 40/465* (2020.01); *A24F 40/51* (2020.01); *A24F 40/53* (2020.01)

(72) Inventors: **Maxime Clément Charles CHATEAU**,  
Montlebon (FR); **Farhang MOHSENI**,  
Neuchatel (CH)

(73) Assignee: **Philip Morris Products S.A.**,  
Neuchatel (CH)

(57) **ABSTRACT**

(21) Appl. No.: **18/852,725**

A method of controlling aerosol production in an aerosol-generating device is provided, the device including a heating chamber to receive an aerosol-generating article including an aerosol-forming substrate; a heating system associated with a heating element to internally heat the substrate from within the substrate; and a power source to provide power to the heating system, the method including receiving the article by the chamber, the substrate having a total aerosol former content greater than 30% by weight and being a solid or gel; heating the substrate by controlling power to: increase a temperature of the heating element to a first temperature, and maintain the first temperature constant for a first time period; controlling power to, during a pre-heating time period before the first time period, increase the temperature from ambient to the initial temperature; and calibrating the heating element after the pre-heating time period and before the first time period.

(22) PCT Filed: **Mar. 31, 2023**

(86) PCT No.: **PCT/EP2023/058482**

§ 371 (c)(1),

(2) Date: **Sep. 30, 2024**

(30) **Foreign Application Priority Data**

Apr. 6, 2022 (EP) ..... 22166997.1

**Publication Classification**

(51) **Int. Cl.**  
*A24F 40/57* (2020.01)  
*A24F 40/10* (2020.01)

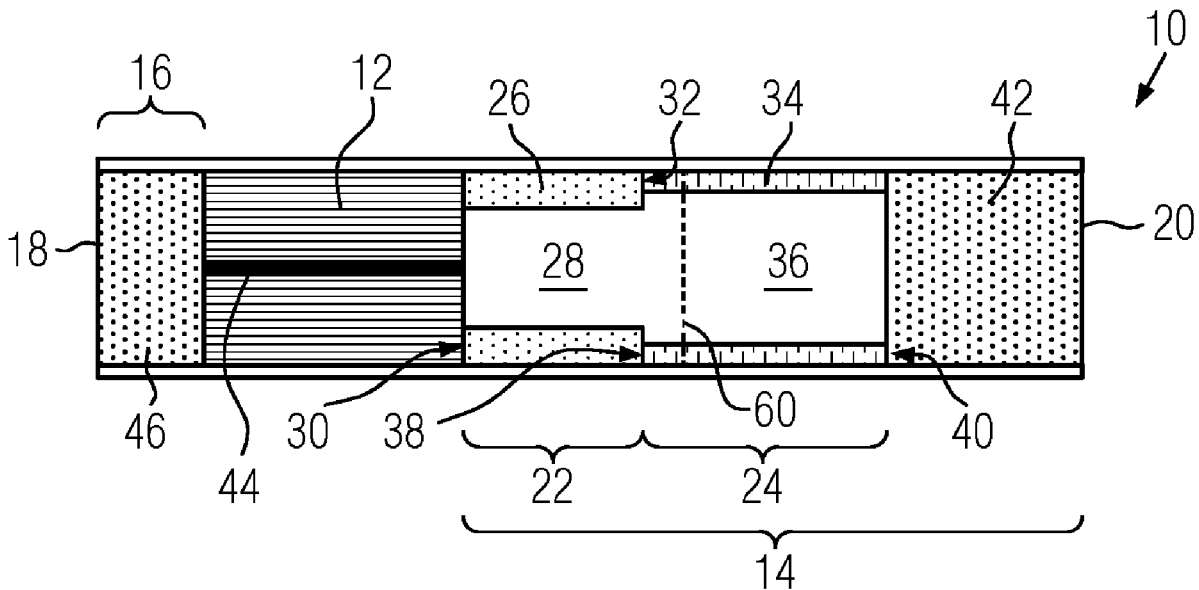

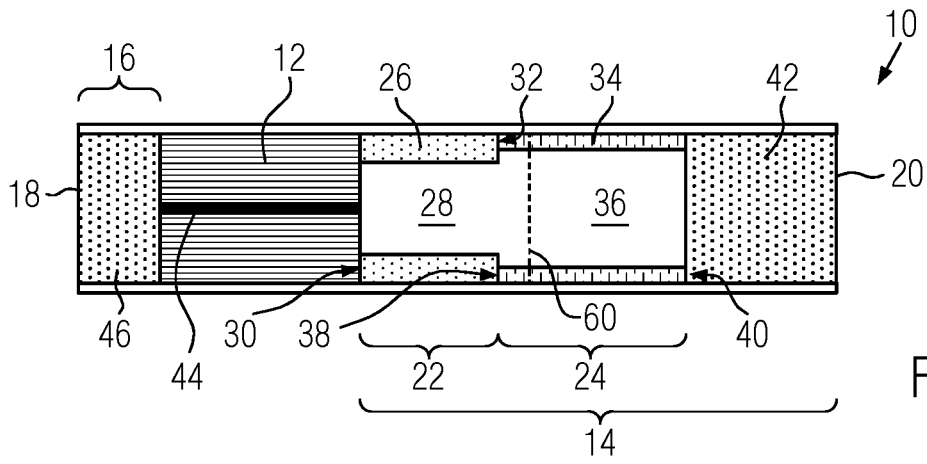

FIG. 1

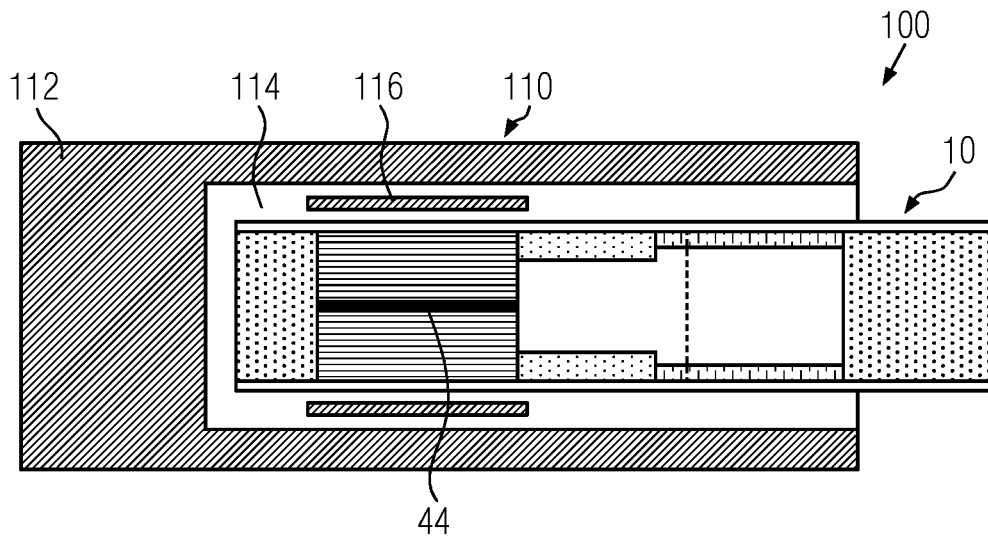

FIG. 2

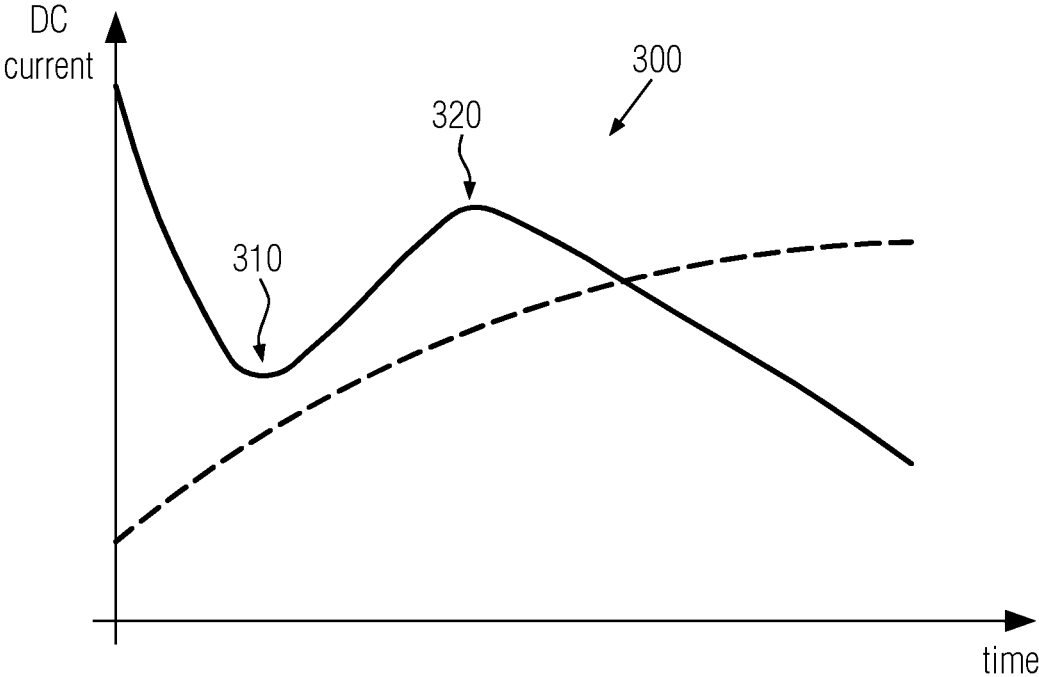

FIG. 3

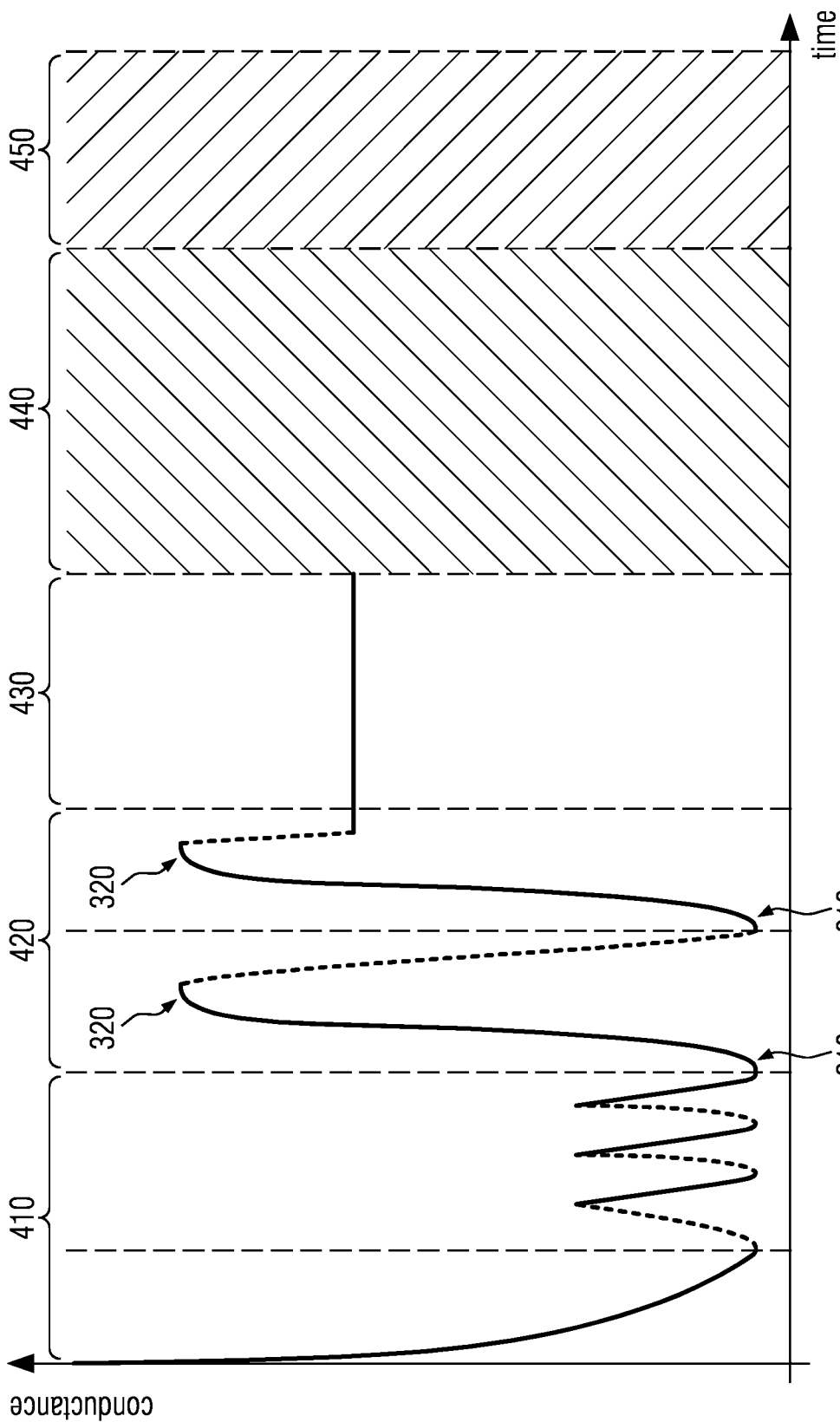

FIG. 4

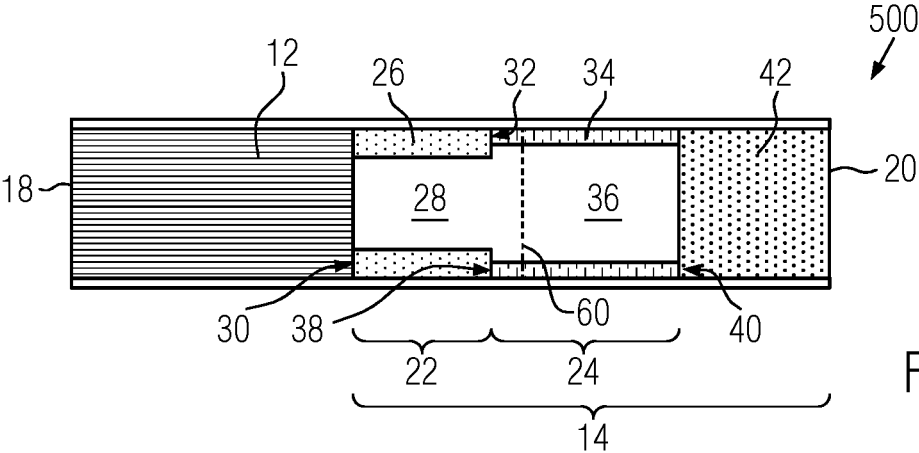

FIG. 5

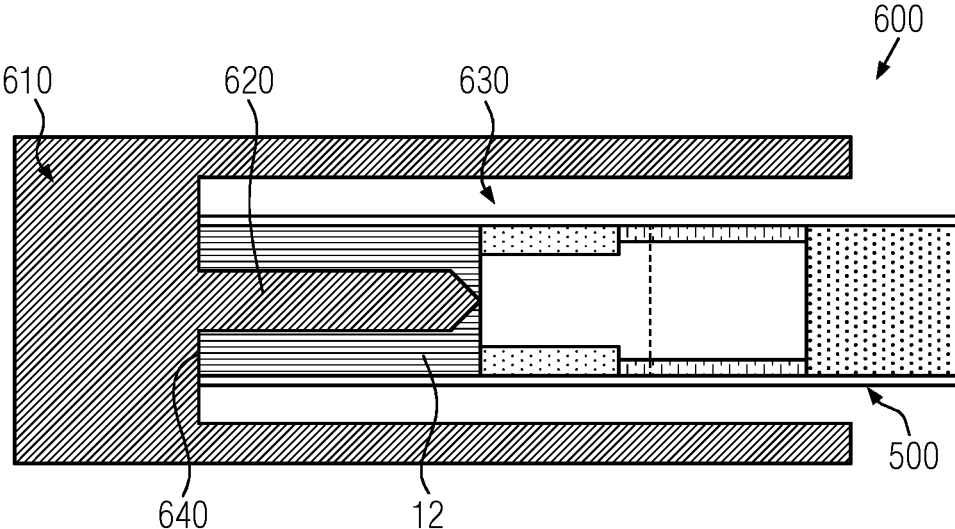

FIG. 6

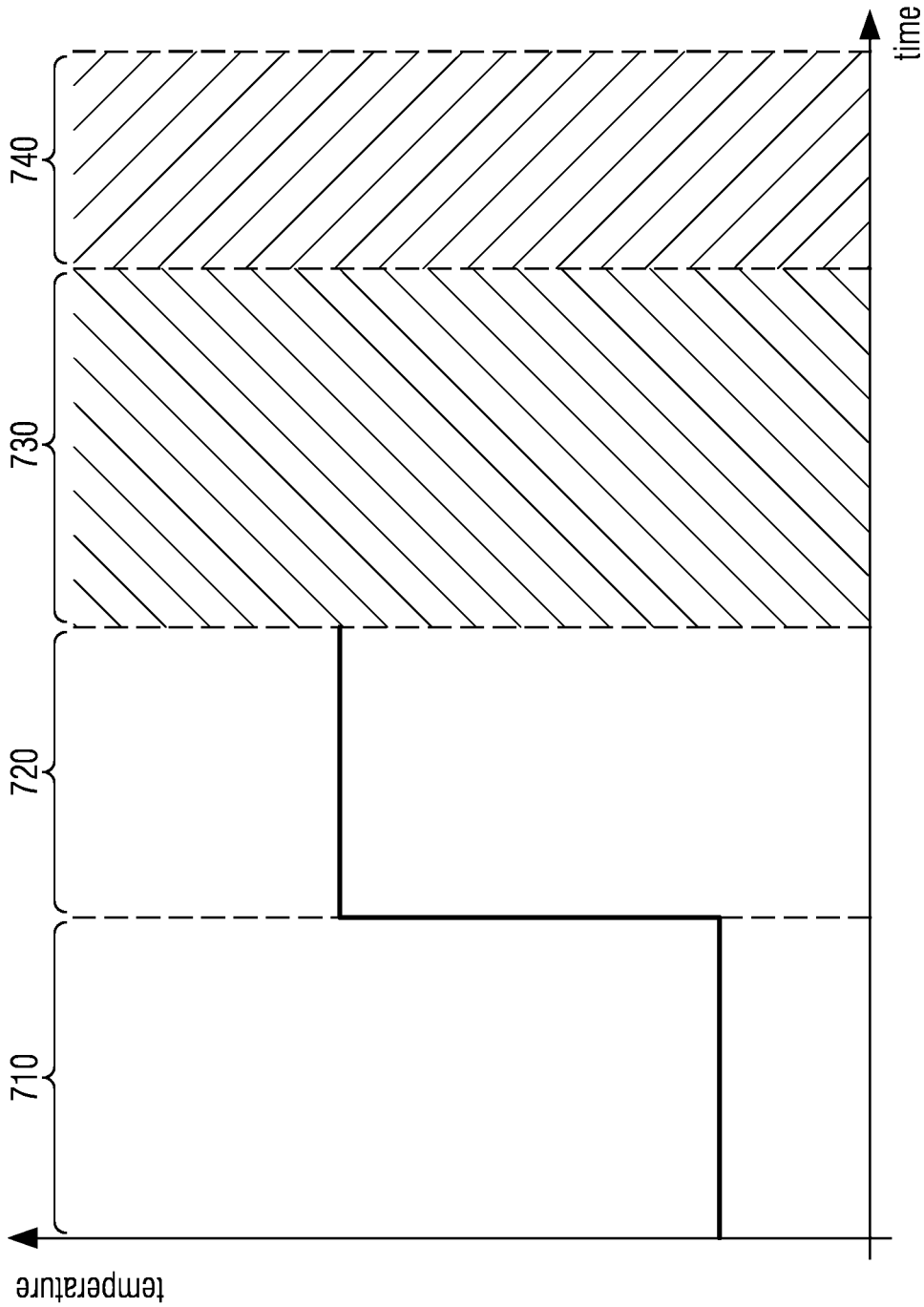

FIG. 7

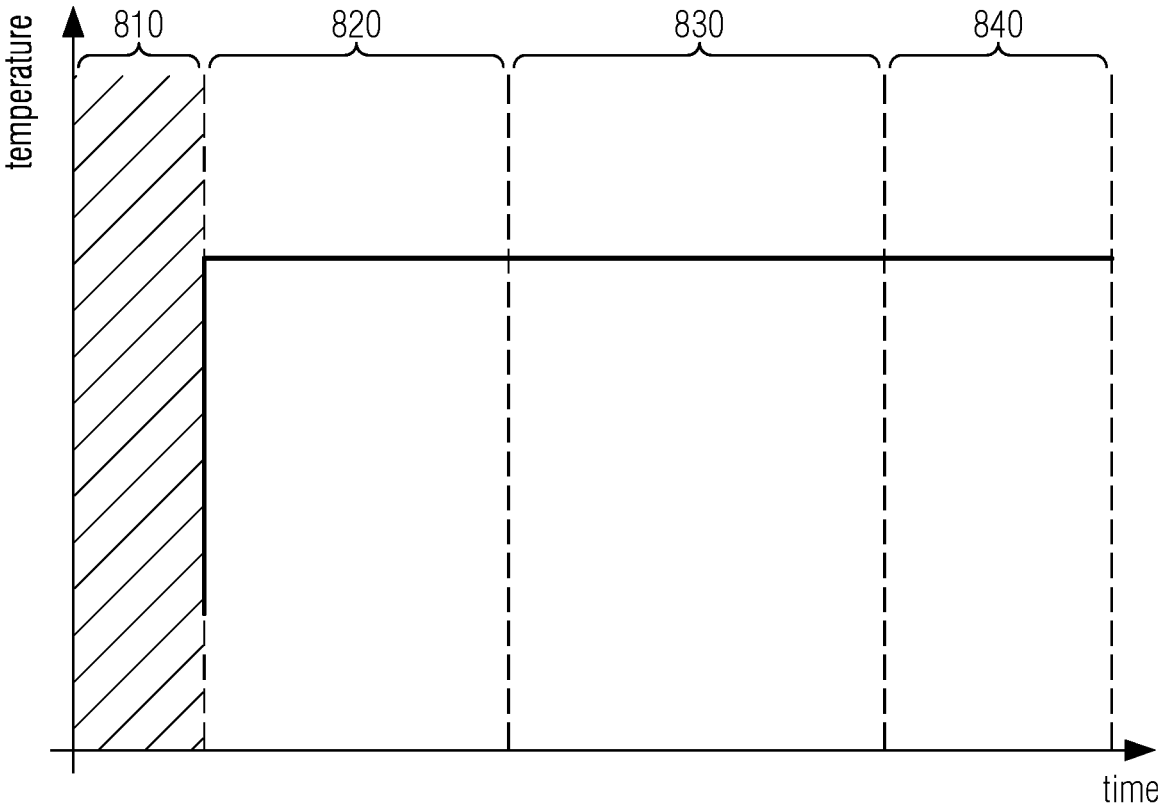

FIG. 8

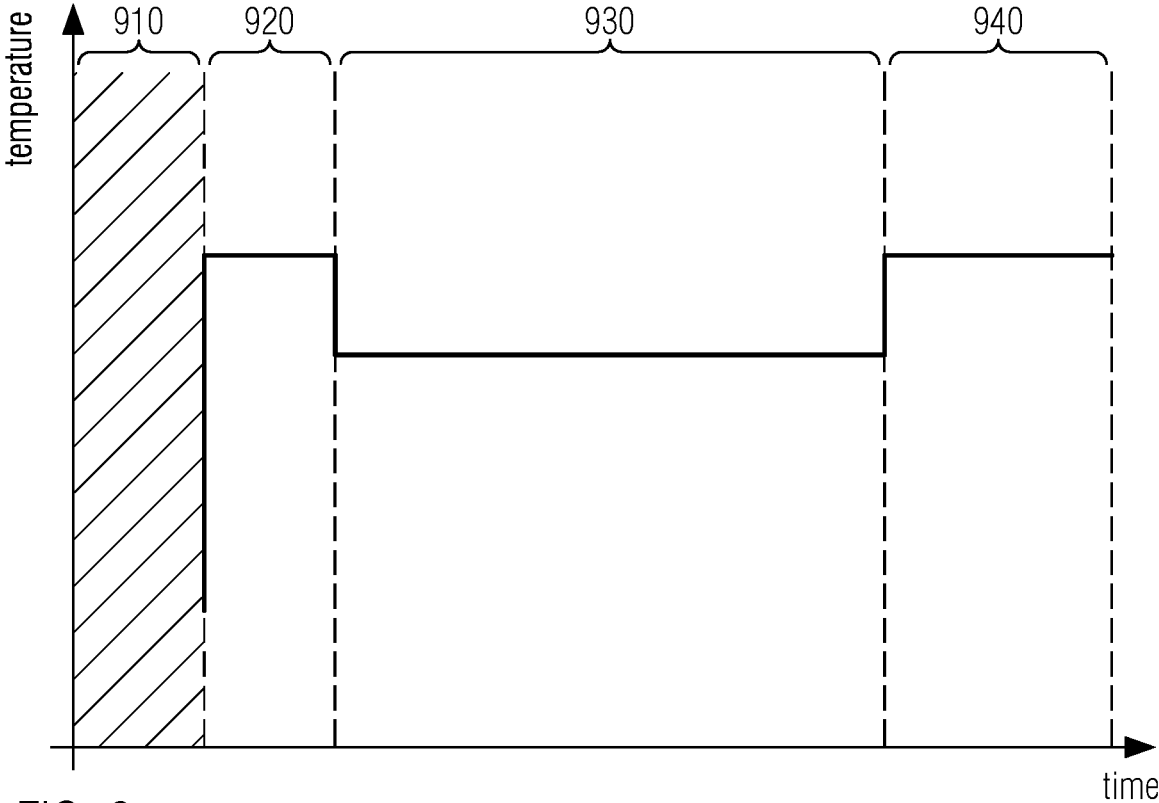

FIG. 9

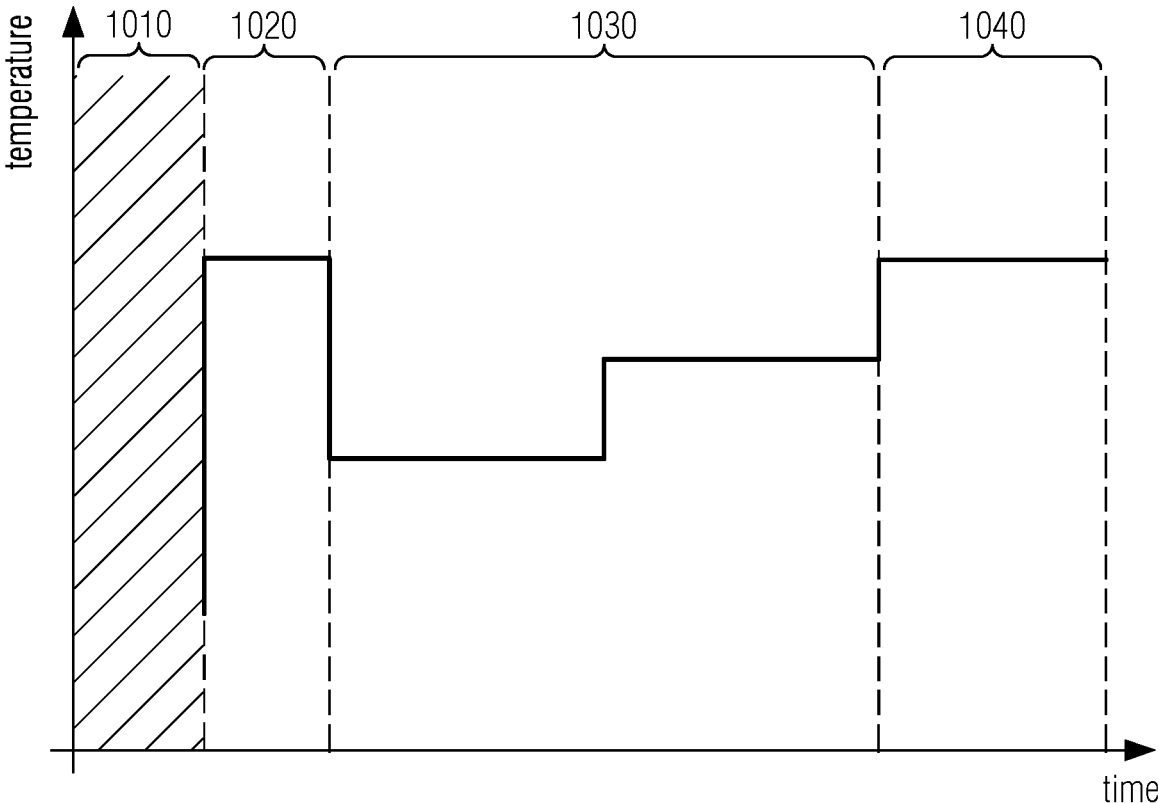

FIG. 10

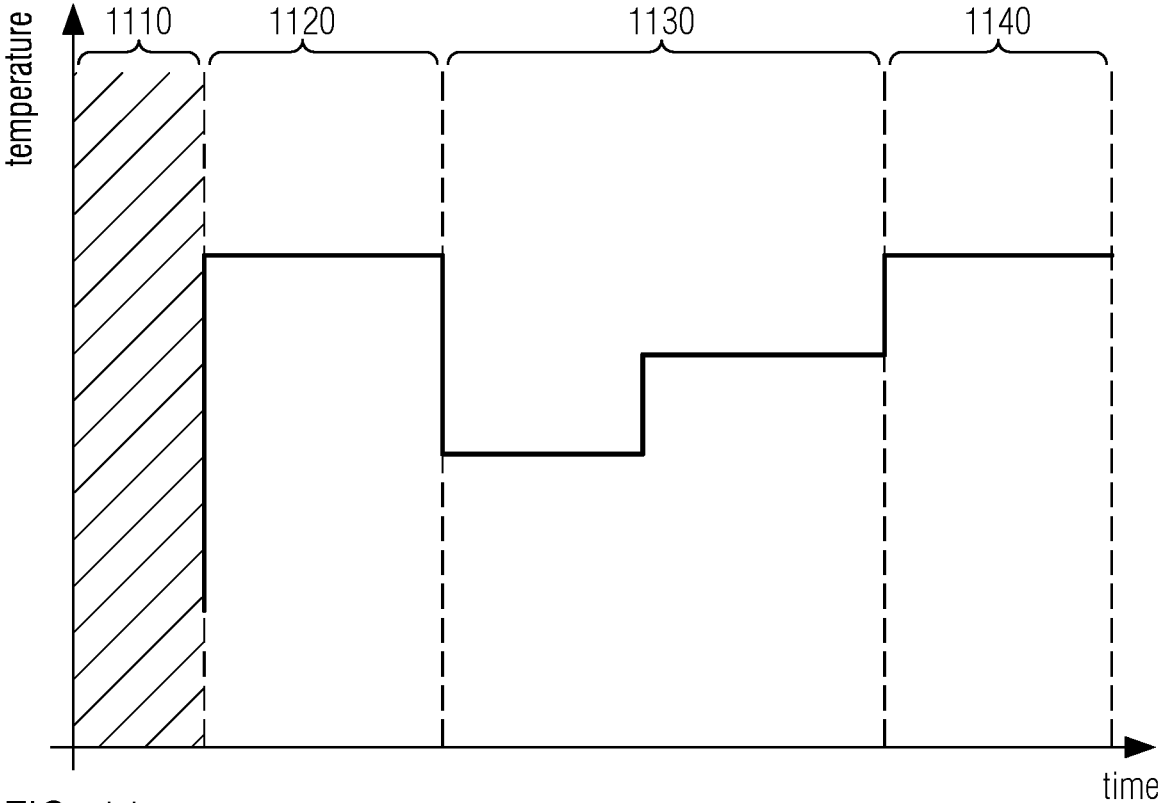

FIG. 11

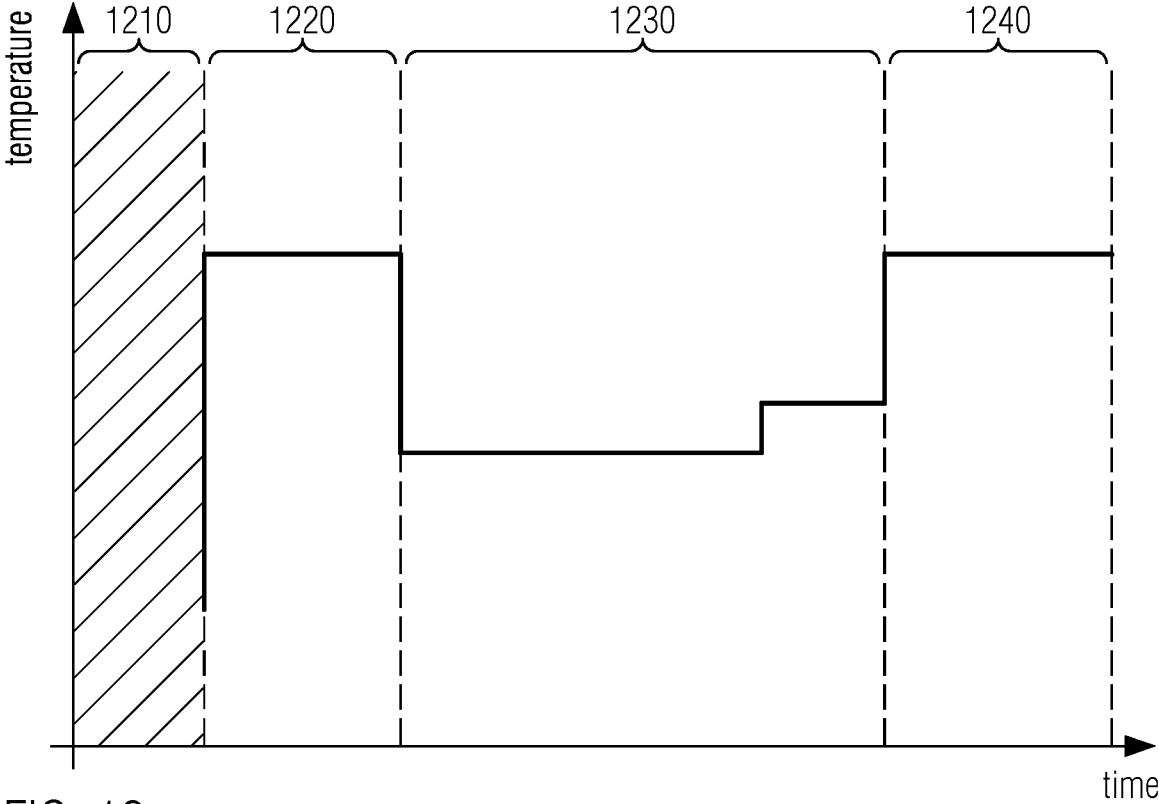

FIG. 12

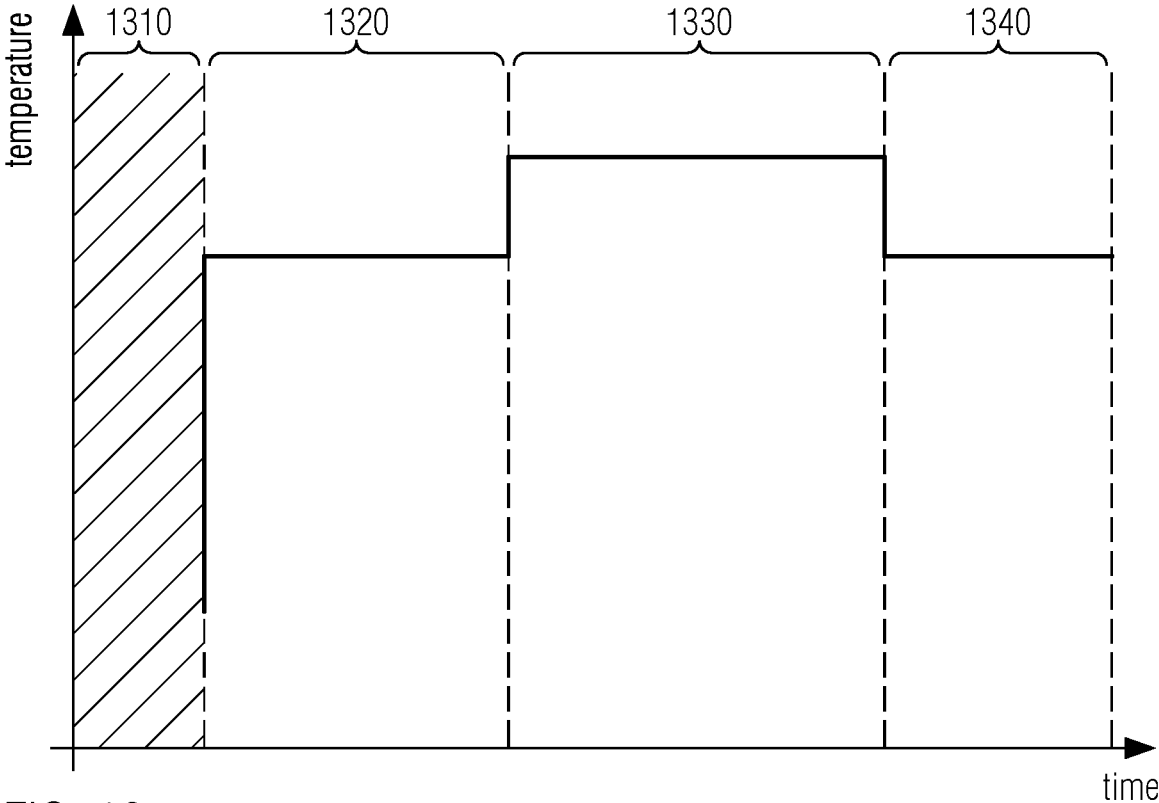

FIG. 13

1400

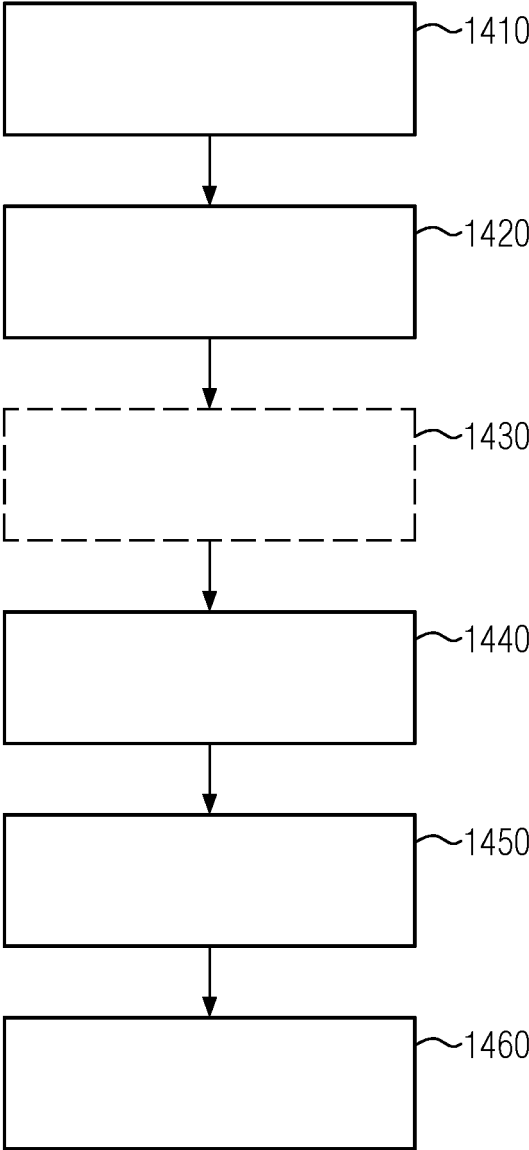

FIG. 14

**AN AEROSOL-GENERATING DEVICE AND  
SYSTEM AND METHOD FOR CONTROL  
THEREOF**

**[0001]** The present disclosure relates to a method of controlling aerosol production in an aerosol-generating device that is configured to heat an aerosol-generating article comprising a solid or a gel aerosol-forming substrate. The present disclosure also relates to the aerosol-generating device and a system comprising the aerosol-generating device and the aerosol-generating article. Aerosol-generating devices may comprise an electrically operated heat source that is configured to heat an aerosol-generating article comprising an aerosol-forming substrate to generate an aerosol. Typically, in heated aerosol-generating articles, an aerosol is generated by the transfer of heat from the heat source to a physically separate aerosol-forming substrate. In use, volatile compounds are released from the aerosol-forming substrate by heat transfer to the aerosol-forming substrate from the heat source and entrained in air drawn through the aerosol-generating article. As the released compounds cool, they condense to form an aerosol that is inhaled by the user.

**[0002]** A number of handheld aerosol-generating devices configured to heat aerosol-forming substrates of heated aerosol-generating articles are known in the art. These include electrically-operated aerosol-generating devices in which an aerosol is generated by the transfer of heat from one or more electrical heating elements of the aerosol-generating device to the aerosol-forming substrate of the heated aerosol-generating article. Known handheld electrically operated aerosol-generating devices typically comprise a battery, control electronics and one or more electrical heating elements for heating the aerosol-forming substrate of a heated aerosol-generating article.

**[0003]** It would be desirable to provide an aerosol-generating device and method of controlling aerosol-production in the aerosol-generating device in which a large amount of volatile compounds are delivered to the user from the first puff and that good deliveries of the volatile compounds are maintained throughout the user experience.

**[0004]** According to an embodiment, there is provided a method of controlling aerosol production in an aerosol-generating device. The device comprises: a heating chamber configured to at least partially receive an aerosol-generating article comprising an aerosol-forming substrate; a heating system associated with a heating element that is configured to internally heat the aerosol-forming substrate from within the aerosol-forming substrate; and a power source for providing power to the heating system. The method comprises: receiving, by the heating chamber, the aerosol-generating article, wherein the aerosol-forming substrate has a total aerosol former content greater than 30 percent by weight, and wherein the aerosol-forming substrate is a solid or a gel; and heating the aerosol-forming substrate to form an aerosol for inhalation by a user by controlling the power to: increase a temperature of the heating element from an initial temperature to a first temperature; and maintain the temperature of the heating element constant at the first temperature for a duration of a first predetermined time period, wherein the first temperature is between 245 and 285 degrees Celsius.

**[0005]** By heating the heating element to within this range of temperatures for the first predetermined time period, the thermal inertia of the aerosol-forming substrate is overcome

and the amount of vaporized desired volatile compounds in the aerosol inhaled by the user is improved from the first puff.

**[0006]** As used herein with reference to the invention, the term “aerosol-generating device” is used to describe a device that interacts with the aerosol forming substrate of an aerosol generating article to generate an aerosol. The aerosol-generating device may be a handheld electrically-operated device.

**[0007]** As used herein with reference to the invention, the term “aerosol-generating article” is used to describe an article comprising an aerosol-forming substrate that is heated to generate an inhalable aerosol for delivery to a user. An aerosol-generating article may be disposable.

**[0008]** As used herein with reference to the invention, the term “aerosol” is used to describe a dispersion of solid particles, or liquid droplets, or a combination of solid particles and liquid droplets, in a gas. The aerosol may be visible or invisible. The aerosol may include vapors of substances that are ordinarily liquid or solid at room temperature as well as solid particles, or liquid droplets, or a combination of solid particles and liquid droplets.

**[0009]** As used herein with reference to the invention, the term “aerosol-forming substrate” is used to describe a substrate comprising aerosol-generating material that is capable of releasing upon heating volatile compounds that can generate an aerosol.

**[0010]** Preferably, the power source is a battery, such as a lithium ion battery. As an alternative, the power source may be another form of charge storage device such as a capacitor. The power source may require recharging. For example, the power source may have sufficient capacity to allow for the continuous generation of aerosol for a period of around six minutes or for a period that is a multiple of six minutes. In another example, the power source may have sufficient capacity to allow for a predetermined number of puffs or discrete activations of the heating system.

**[0011]** As used herein with reference to the invention, the term “aerosol former” is used to describe a compound that, in use, facilitates formation of the aerosol, and that preferably is substantially resistant to thermal degradation at the operating temperature of an aerosol-generating article or aerosol-generating system comprising the aerosol-forming substrate.

**[0012]** As used herein with reference to the invention, the term “total aerosol former content” is used to describe the combined content of all aerosol formers in the aerosol-forming substrate.

**[0013]** Unless stated otherwise, percentages by weight of components of the aerosol-forming substrate recited herein are based on the dry weight of the aerosol-forming substrate.

**[0014]** As used herein with reference to the invention, the term “solid” is used to describe an aerosol-forming substrate that has a stable size and shape and does not flow at 23° C.

**[0015]** As used herein with reference to the invention, the term “gel” is used to describe an aerosol-forming substrate that comprises two or more components, one of which is a liquid. A gel is mostly liquid by weight. A gel is a substantially dilute cross-linked system, which exhibits no flow when in the steady state, although the liquid phase may still diffuse through the system.

**[0016]** The first time period may have a duration of 40 seconds to 300 seconds, preferably 40 seconds to 150 seconds.

[0017] Controlling the power may further comprise adjusting the temperature of the heating element to a second temperature during a second predetermined time period, wherein the second predetermined time period is subsequent to the first predetermined time period.

[0018] The second predetermined time period may be directly subsequent to the first predetermined time period.

[0019] The second temperature may be different to the first temperature.

[0020] The second temperature may be lower than the first temperature.

[0021] Lowering the temperature of the heating element in the second heating mode enables the amount of vaporized desired volatile compounds in the aerosol inhaled by the user to remain consistent with the amount in the first predetermined time period, thereby providing the same sensorial experience for the user.

[0022] The second temperature may be between 190 and 220 degrees Celsius.

[0023] Adjusting the temperature of the heating element to the second temperature during the second time period may comprise two consecutive temperature steps.

[0024] A temperature of a first temperature step may be lower than a temperature of a second temperature step.

[0025] Having two temperature steps in the second heating mode allows for improved control of the amount of vaporized desired volatile compounds in the aerosol inhaled by the user, thereby providing the same sensorial experience for the user. Further, if the temperature of the second heating step is higher than the temperature of the first heating step, the amount of desired vaporized volatile compounds remains consistent even though the amount of desired volatile compounds depletes over time with heating.

[0026] Adjusting the temperature of the heating element to a second temperature during the second predetermined time period may comprise increasing the temperature of the heating element from the first temperature.

[0027] A duration of the second predetermined time period may be between 100 and 280 seconds. Controlling the power may further comprise adjusting the temperature of the heating element to a third temperature during a third predetermined time period, wherein the third predetermined time period is subsequent to the second predetermined time period.

[0028] The third temperature may approximately correspond to the first temperature.

[0029] Performing the heating of the aerosol-forming substrate to form an aerosol for inhalation by a user into three predetermined time periods in which the temperature of the heating element is adjusted to a respective temperature, enables improved control of aerosol delivery. In particular, towards the end of a user session in the third predetermined time period, the amount of desired volatile compounds to be vaporized for inhalation by the user will be depleted. Increasing the temperature of the heating element to approximately the first temperature enables the amount of vaporized desired volatile compounds in the aerosol inhaled by the user to remain consistent with the amount in the first and second predetermined time periods.

[0030] A duration of the third predetermined time period may be between 30 seconds and 120 seconds. The third predetermined time period may be directly subsequent to the second predetermined time period.

[0031] The power may be controlled based on a heating profile of a plurality of heating profiles, wherein each heating profile defines how to adjust the temperature of the heating element during each of the time periods.

[0032] The method may further comprise selecting the heating profile based on identifying the aerosol-generating article.

[0033] The power may be controlled based on a heating profile of a plurality of heating profiles, wherein each heating profile may define how to adjust the temperature of the heating element during the second time period.

[0034] The method may further comprise selecting the heating profile based on identifying the aerosol-generating article.

[0035] The heating system may comprise an induction coil configured to inductively heat the heating element.

[0036] As used herein, the term “inductively heat” refers to the heating of a heating element, such as a susceptor when penetrated by an alternating magnetic field. The heating may be caused by the generation of eddy currents in the heating element. The heating may be caused by magnetic hysteresis losses.

[0037] The heating element may be a susceptor. As used herein, the term “susceptor” refers to an element comprising a material that is capable of converting the energy of a magnetic field into heat. When a susceptor is located in an alternating magnetic field, the susceptor is heated. Heating of the susceptor may be the result of at least one of hysteresis losses and eddy currents induced in the susceptor, depending on the electrical and magnetic properties of the susceptor material. The susceptor may be an elongate susceptor. As used herein with reference to the term “elongate” is used to describe a susceptor having a length that is greater than the width thereof. For example, the length of the susceptor may be at least twice the width thereof.

[0038] The method may further comprise controlling the power to: during a pre-heating time period before the first predetermined time period, increasing the temperature of the heating element from an ambient temperature to the initial temperature.

[0039] The pre-heating time period may have a duration between 10 and 20 seconds.

[0040] The pre-heating time period ensures that, whatever the physical condition of the aerosol-forming substrate (dry or humid, for example), the time duration of the pre-heating time period is sufficient for the aerosol-forming substrate to reach a minimum operating temperature, in order to be ready to feed continuous power and reach the first operating temperature as quickly as possible for generating sufficient aerosol to be inhaled by the user. This is particularly advantageous for aerosol-forming substrates having a high aerosol former content (greater than 30 percent by 15 weight) because such substrates typically have a higher moisture content after thermal equilibrium has been reached.

[0041] The method may further comprise calibrating the heating element subsequent to the pre-heating time period and before the first predetermined time period.

[0042] Calibrating the heating element during heating of the aerosol-forming substrate for generating an aerosol (as opposed to during manufacture) advantageously provides for more accurate determination of the calibration values used in the temperature control, and therefore improved temperature control is achieved.

[0043] The heating system may further comprise the heating element, the heating element being a resistive heating element.

[0044] The method may further comprise controlling the power to: during a pre-heating time period before the first predetermined time period, increasing the temperature of the heating element from an ambient temperature to the initial temperature.

[0045] The pre-heating time period may have a duration between 10 and 20 seconds.

[0046] The pre-heating time period ensures that, whatever the physical condition of the aerosol-forming substrate (dry or humid, for example), the time duration of the pre-heating time period is sufficient for the aerosol-forming substrate to reach a minimum operating temperature, in order to be ready to feed continuous power and reach the first operating temperature as quickly as possible for generating sufficient aerosol to be inhaled by the user. This is particularly advantageous for aerosol-forming substrates having a high aerosol former content (greater than 30 percent by weight) because such substrates typically have a higher moisture content after thermal equilibrium has been reached.

[0047] The aerosol-forming substrate may comprise a total aerosol-former content that is greater than 35 percent by weight. The aerosol-forming substrate may comprise a total aerosol-former content that is greater than 40 percent by weight. The aerosol-forming substrate may comprise a total aerosol-former content that is greater than 45 percent by weight.

[0048] The aerosol-forming substrate may comprise one or more aerosol formers selected from 1,3-butanediol, glycerin, 1,3-propanediol, propylene glycol, triethylene glycol, glycerol monoacetate, glycerol diacetate, glycerol triacetate, dimethyl dodecanedioate and dimethyl tetradecanedioate.

[0049] The aerosol-forming substrate may not include tobacco.

[0050] The aerosol-forming substrate may further comprise nicotine.

[0051] As used herein with reference to the invention, the term “nicotine” is used to describe nicotine, a nicotine base or a nicotine salt. In embodiments in which the aerosol-forming substrate comprises a nicotine base or a nicotine salt, the amounts of nicotine recited herein are the amount of free base nicotine or amount of protonated nicotine, respectively.

[0052] The aerosol-forming substrate may comprise natural nicotine, or synthetic nicotine, or a combination of natural nicotine and synthetic nicotine.

[0053] The aerosol-forming substrate may further comprise one or more cellulose based agents and one or more carboxylic acids selected from fumaric acid, maleic acid and malic acid.

[0054] The aerosol-forming substrate may have a total cellulose based agent content of at least 35 percent by weight and a total carboxylic acid content of at least 0.5 percent by weight.

[0055] As used herein with reference to the invention, the term “cellulose based agent” is used to describe a cellulosic substance. Examples of cellulose based agents include cellulose based film-forming agents, cellulose based strengthening agents and cellulose based binding agents. For example, where the aerosol-forming substrate comprises a plurality of cellulose based agents consisting of a cellulose based film-forming agent, a cellulose based strengthening

agent, and a cellulose based binding agent, the term “total cellulose based agent content” describes the combined cellulose based film-forming agent content, cellulose based strengthening agent content, and cellulose based binding agent content of the aerosol-forming substrate.

[0056] As used herein with reference to the invention, the term “total carboxylic acid content” is used to describe the combined content of all carboxylic acids in the aerosol-forming substrate. For example, where the aerosol-forming substrate comprises a plurality of carboxylic acids consisting of benzoic acid and fumaric acid, the term “total carboxylic acid content” describes the combined benzoic acid content and fumaric acid content of the aerosol-forming substrate.

[0057] The aerosol-forming substrate may comprise water.

[0058] The aerosol-forming substrate may have a water content of between 5 percent by weight and 35 percent by weight.

[0059] The aerosol-forming substrate may be a solid film.

[0060] As used herein with reference to the invention, the term “film” is used to describe a solid aerosol-forming substrate having a thickness that is substantially less than the width or length thereof.

[0061] As used herein with reference to the invention, the term “thickness” is used to describe the minimum dimension between opposite, substantially parallel surfaces of a solid aerosol-generating film.

[0062] According to a further embodiment, there is provided an aerosol-generating article comprising an aerosol-forming substrate having a total aerosol former content greater than or equal to 30 percent by weight, and wherein the aerosol former substrate is a solid or a gel; and an aerosol-generating device. The aerosol-generating device comprises: a heating chamber configured to at least partially receive the aerosol-generating article; a heating system associated with a heating element that is configured to internally heat the aerosol-forming substrate from within the aerosol-forming substrate; a power source for providing power to the heating system; and a controller configured to control the power during heating of the aerosol-forming substrate to form an aerosol for inhalation by a user to: increase a temperature of the heating element from an initial temperature to a first temperature; and maintain the temperature of the heating element constant at the first temperature for a duration of a first predetermined time period, wherein the first temperature is between 245 and 285 degrees Celsius.

[0063] The first time period may have a duration of 40 seconds to 300 seconds, preferably 40 seconds to 150 seconds.

[0064] Controlling the power during heating of the aerosol-forming substrate to form an aerosol for inhalation by a user may further comprise adjusting the temperature of the heating element to a second temperature during a second predetermined time period, wherein the second predetermined time period may be subsequent to the first predetermined time period.

[0065] The second predetermined time period may be directly subsequent to the first predetermined time period.

[0066] The second temperature may be different to the first temperature.

[0067] The second temperature may be lower than the first temperature.

[0068] The second temperature may be between 190 and 220 degrees Celsius.

[0069] Adjusting the temperature of the heating element to the second temperature during the second predetermined time period may comprise two consecutive temperature steps.

[0070] A temperature of a first temperature step may be lower than a temperature of a second temperature step.

[0071] Adjusting the temperature of the heating element to a second temperature during the second predetermined time period may comprise increasing the temperature of the heating element from the first temperature.

[0072] A duration of the second predetermined time period may be between 100 and 280 seconds. Controlling the power during heating of the aerosol-forming substrate to form an aerosol for inhalation by a user may further comprise adjusting the temperature of the heating element to a third temperature during a third predetermined time period, wherein the third predetermined time period may be subsequent to the second predetermined time period.

[0073] The third temperature may approximately correspond to the first temperature.

[0074] The third predetermined time period may be directly subsequent to the second predetermined time period.

[0075] A duration of the third predetermined time period may be between 30 seconds and 120 seconds.

[0076] The aerosol-generating device may further comprise a memory configured to store a plurality of heating profiles, wherein each heating profile may define how to adjust the temperature of the heating element during each of the time periods, and wherein the controller is may be further configured to control the power during heating of the aerosol-forming substrate to form an aerosol for inhalation by a user based on a heating profile of the plurality of heating profiles.

[0077] The controller may be further configured to select the heating profile based on identifying the aerosol-generating article.

[0078] The aerosol-generating device may further comprise a memory configured to store a plurality of heating profiles, wherein each heating profile may define how to adjust the temperature of the heating element during the second predetermined time period, and wherein the controller may be further configured to control the power during heating of the aerosol-forming substrate to form an aerosol for inhalation by a user based on a heating profile of the plurality of heating profiles.

[0079] The controller may be further configured to select the heating profile based on identifying the aerosol-generating article.

[0080] The aerosol-forming substrate may further comprise the heating element, wherein the heating system may comprise an induction coil for inductively heating the heating element.

[0081] The controller may be further configured to: during a pre-heating time period before the first predetermined time period, control the power to increase the temperature of the heating element from an ambient temperature to the initial temperature.

[0082] The pre-heating time period may have a duration between 10 and 20 seconds.

[0083] The controller may be further configured to calibrate the heating element subsequent to the pre-heating time period and before the first time period.

[0084] The heating system may comprise the heating element, the heating element being a resistive heating element.

[0085] The controller may be further configured to: during a pre-heating time period before the first predetermined time period, control the power to increase the temperature of the heating element from an ambient temperature to the initial temperature.

[0086] The pre-heating time period may have a duration between 10 and 20 seconds.

[0087] The aerosol-forming substrate may comprise a total aerosol-former content that is greater than 35 percent by weight.

[0088] The aerosol-forming substrate may comprise a total aerosol-former content that is greater than 40 percent by weight.

[0089] The aerosol-forming substrate may comprise a total aerosol-former content that is greater than 45 percent by weight.

[0090] The aerosol-forming substrate may comprise one or more aerosol formers selected from 1,3-butanediol, glycerin, 1,3-propanediol, propylene glycol, triethylene glycol, glycerol monoacetate, glycerol diacetate, glycerol triacetate, dimethyl dodecanedioate and dimethyl tetradecanedioate.

[0091] The aerosol-forming substrate may not include tobacco.

[0092] The aerosol-forming substrate may further comprise nicotine.

[0093] The aerosol-forming substrate may further comprise one or more cellulose based agents and one or more carboxylic acids selected from fumaric acid, maleic acid and malic acid.

[0094] The aerosol-forming substrate may have a total cellulose based agent content of at least 35 percent by weight and a total carboxylic acid content of at least 0.5 percent by weight.

[0095] The aerosol-forming substrate may comprise water.

[0096] The aerosol-forming substrate may have a water content of between 5 percent by weight and 35 percent by weight.

[0097] As used herein, the terms “puff” and “inhalation” are used interchangeably and are intended to mean the action of a user drawing an aerosol into their body through their mouth or nose. Inhalation includes the situation where an aerosol is drawn into the user’s lungs, and also the situation where an aerosol is only drawn into the user’s mouth or nasal cavity before being expelled from the user’s body.

[0098] As used herein, a “usage session” refers to a period of use of the device beginning with activation of the device by the user. The usage session may comprise a pre-heating phase in which the aerosol-generating device is configured to supply power to the heating system to heat the aerosol-forming substrate to generate aerosol. The usage session may comprise a calibration phase to calibrate the heating system in order to more accurately control the temperature of the heating element. The usage session may comprise a main phase during which the user may inhale the generated aerosol. The main phase may be 30 long enough for a plurality of puffs. The main phase may be long enough for three, four, five or six puffs. The main phase may be long

enough for more than six puffs. At the end of the usage phase, the aerosol-generating device may be configured to stop supplying power to the heating system. The aerosol-forming substrate may be removed from the aerosol-generating device at the end of the usage session. The aerosol-forming substrate may be replaced in a later usage session. The duration of the usage session, between a usage session start and a usage session end may be at least one, two, three, four, five or six minutes. Preferably, the usage session may have a duration of about four and a half minutes.

**[0099]** As used herein when referring to an aerosol-generating device, the terms “upstream” and “front”, and “downstream” and “rear”, are used to describe the relative positions of components, or portions of components, of the aerosol-generating device in relation to the direction in which air flows through the aerosol-generating device during use thereof. Aerosol-generating devices according to the invention comprise a proximal end through which, in use, an aerosol exits the device. The proximal end of the aerosol-generating device may also be referred to as the mouth end or the downstream end. The mouth end is downstream of the distal end. The distal end of the aerosol-generating article may also be referred to as the upstream end. Components, or portions of components, of the aerosol-generating device may be described as being upstream or downstream of one another based on their relative positions with respect to the airflow path of the aerosol-generating device.

**[0100]** As used herein when referring to an aerosol-generating article, the terms “upstream” and “front”, and “downstream” and “rear”, are used to describe the relative positions of components, or portions of components, of the aerosol-generating article in relation to the direction in which air flows through the aerosol-generating article during use thereof. Aerosol-generating articles according to the invention comprise a proximal end through which, in use, an aerosol exits the article. The proximal end of the aerosol-generating article may also be referred to as the mouth end or the downstream end. The mouth end is downstream of the distal end. The distal end of the aerosol-generating article may also be referred to as the upstream end. Components, or portions of components, of the aerosol-generating article may be described as being upstream or downstream of one another based on their relative positions between the proximal end of the aerosol-generating article and the distal end of the aerosol-generating article. The front of a component, or portion of a component, of the aerosol-generating article is the portion at the end closest to the upstream end of the aerosol-generating article. The rear of a component, or portion of a component, of the aerosol-generating article is the portion at the end closest to the downstream end of the aerosol-generating article.

**[0101]** As used herein, “aerosol-cooling element” refers to a component of an aerosol-generating article located downstream of the aerosol-forming substrate such that, in use, an aerosol formed by volatile compounds released from the aerosol-forming substrate passes through and is cooled by the aerosol cooling element before being inhaled by a user. An aerosol cooling element has a large surface area, but causes a low pressure drop. Filters and other mouthpieces that produce a high pressure drop, for example filters formed from bundles of fibers, are not considered to be aerosol-cooling elements. Chambers and cavities within an aerosol-generating article are not considered to be aerosol cooling elements.

**[0102]** As used herein, the term “mouthpiece” refers to a portion of an aerosol-generating article, an aerosol-generating device or an aerosol-generating system that is placed into a user’s mouth in order to directly inhale an aerosol.

**[0103]** As used herein with reference to the invention, the term “mode” refers to a mode of operation that the controller is programmed to perform. For example, in a calibration mode, the controller is configured to perform a pre-programmed calibration process. In a pre-heating mode, the controller is configured to perform a pre-programmed pre-heating process. In a heating mode, the controller is configured to perform a heating process. The term “phase” may be used herein interchangeably with the term “mode”. The controller may be a microcontroller. The controller may comprise a microprocessor, such as a programmable microprocessor. The controller may comprise a non-volatile memory. The aerosol-generating device may comprise an interface configured to allow for the transfer of data to and from the controller from external devices. The interface may allow for the uploading of software to the controller to run on the programmable microprocessor. The interface may be a wired interface, such as a micro USB port, or may be a wireless interface.

**[0104]** The invention is defined in the claims. However, below there is provided a non-exhaustive list of non-limiting examples. Any one or more of the features of these examples may be combined with any one or more features of another example, embodiment, or aspect described herein.

**[0105]** Example Ex1: A method of controlling aerosol production in an aerosol-generating device, the device comprising: a heating chamber configured to at least partially receive an aerosol-generating article comprising an aerosol-forming substrate; a heating system associated with a heating element that is configured to internally heat the aerosol-forming substrate from within the aerosol-forming substrate; and a power source for providing power to the heating system, the method comprising: receiving, by the heating chamber, the aerosol-generating article, wherein the aerosol-forming substrate has a total aerosol former content greater than 30 percent by weight, and wherein the aerosol-forming substrate is a solid or a gel; and heating the aerosol-forming substrate to form an aerosol for inhalation by a user by controlling the power to: increase a temperature of the heating element from an initial temperature to a first temperature; and maintain the temperature of the heating element constant at the first temperature for a duration of a first predetermined time period, wherein the first temperature is between 245 and 285 degrees Celsius.

**[0106]** Example Ex2: The method according to example Ex1, wherein the first time period has a duration of 40 seconds to 300 seconds, preferably 40 seconds to 150 seconds.

**[0107]** Example Ex3: The method according to the preceding examples, wherein controlling the power further comprises adjusting the temperature of the heating element to a second temperature during a second predetermined time period, wherein the second predetermined time period is subsequent to the first predetermined time period.

**[0108]** Example Ex4: The method according to example Ex3, wherein the second temperature is different to the first temperature.

**[0109]** Example Ex5: The method according to example Ex3 or Ex4, wherein the second temperature is lower than the first temperature.

[0110] Example Ex6: The method according to example Ex5, wherein the second temperature is between 190 and 220 degrees Celsius.

[0111] Example Ex7: The method according to one of examples Ex3 to Ex6, wherein adjusting the temperature of the heating element to the second temperature during the second time period comprises two consecutive temperature steps.

[0112] Example Ex8: The method according to example Ex7, wherein a temperature of a first temperature step is lower than a temperature of a second temperature step.

[0113] Example Ex9: The method according to example Ex3 or Ex4, wherein adjusting the temperature of the heating element to a second temperature during the second predetermined time period comprises increasing the temperature of the heating element from the first temperature.

[0114] Example Ex10: The method according to one of examples Ex3 to Ex9, wherein a duration of the second predetermined time period is between 100 and 280 seconds.

[0115] Example Ex11: The method according to one of examples Ex3 to Ex10, wherein controlling the power further comprises adjusting the temperature of the heating element to a third temperature during a third predetermined time period, wherein the third predetermined time period is subsequent to the second predetermined time period.

[0116] Example Ex12: The method according to example Ex11, wherein the third temperature approximately corresponds to the first temperature.

[0117] Example Ex13: The method according to example Ex11 or Ex12, wherein a duration of the third predetermined time period is between 30 seconds and 120 seconds.

[0118] Example Ex14: The method according to one examples Ex3 to Ex13, wherein the power is controlled based on a heating profile of a plurality of heating profiles, wherein each heating profile defines how to adjust the temperature of the heating element during each of the time periods.

[0119] Example Ex15: The method according to example Ex14, further comprising selecting the heating profile based on identifying the aerosol-generating article.

[0120] Example Ex16: The method according to one of examples Ex3 to Ex13 wherein the power is controlled based on a heating profile of a plurality of heating profiles, wherein each heating profile defines how to adjust the temperature of the heating element during the second time period. Example Ex17: The method according to example Ex16, further comprising selecting the heating profile based on identifying the aerosol-generating article.

[0121] Example Ex18: The method according to one of the preceding examples, wherein the heating system comprises an induction coil configured to inductively heat the heating element.

[0122] Example Ex19: The method according to one of the preceding examples, wherein the method further comprises controlling the power to: during a pre-heating time period before the first predetermined time period, increasing the temperature of the heating element from an ambient temperature to the initial temperature.

[0123] Example Ex20: The method according to example Ex19, wherein the pre-heating time period has a duration between 10 and 20 seconds.

[0124] Example Ex21: The method according to one of examples Ex19 or Ex20, further comprising calibrating the

heating element subsequent to the pre-heating time period and before the first predetermined time period.

[0125] Example Ex22: The method according to one of examples Ex1 to Ex17, wherein the heating system comprises the heating element, the heating element being a resistive heating element.

[0126] Example Ex23: The method according to example Ex22, wherein the method further comprises controlling the power to: during a pre-heating time period before the first predetermined time period, increasing the temperature of the heating element from an ambient temperature to the initial temperature.

[0127] Example Ex24: The method according to example Ex23, wherein the pre-heating time period has a duration between 10 and 20 seconds.

[0128] Example Ex25: The method according to one of the preceding examples, wherein the aerosol-forming substrate comprises a total aerosol-former content that is greater than 35 percent by weight.

[0129] Example Ex26: The method according to one of the preceding examples, wherein the aerosol-forming substrate comprises a total aerosol-former content that is greater than 40 percent by weight.

[0130] Example Ex27: The method according to one of the preceding examples, wherein the aerosol-forming substrate comprises a total aerosol-former content that is greater than 45 percent by weight.

[0131] Example Ex28: The method according to one of the preceding examples, wherein the aerosol-forming substrate comprises one or more aerosol formers selected from 1,3-butanediol, glycerin, 1,3-propanediol, propylene glycol, triethylene glycol, glycerol monoacetate, glycerol diacetate, glycerol triacetate, dimethyl dodecanedioate and dimethyl tetradecanedioate.

[0132] Example Ex29: The method according to one of the preceding examples, wherein the aerosol-forming substrate does not include tobacco.

[0133] Example Ex30: The method according to one of the preceding examples, wherein the aerosol-forming substrate further comprises nicotine.

[0134] Example Ex31: The method according to one of the preceding examples, wherein the aerosol-forming substrate further comprises one or more cellulose based agents and one or more carboxylic acids selected from fumaric acid, maleic acid and malic acid.

[0135] Examples Ex32. The method according to example Ex31, wherein the aerosol-forming substrate has a total cellulose based agent content of at least 35 percent by weight and a total carboxylic acid content of at least 0.5 percent by weight.

[0136] Example Ex33: The method according to one of the preceding examples, wherein the aerosol-forming substrate comprises water.

[0137] Example Ex34: The method according to example Ex33, wherein the aerosol-forming substrate has a water content of between 5 percent by weight and 35 percent by weight.

[0138] Example Ex35: A system comprising: an aerosol-generating article comprising an aerosol-forming substrate having a total aerosol former content greater than or equal to 30 percent by weight, and wherein the aerosol former substrate is a solid or a gel; and an aerosol-generating device, comprising: a heating chamber configured to at least partially receive the aerosol-generating article; a heating

system associated with a heating element that is configured to internally heat the aerosol-forming substrate from within the aerosol-forming substrate; a power source for providing power to the heating system; and a controller configured to control the power during heating of the aerosol-forming substrate to form an aerosol for inhalation by a user to: increase a temperature of the heating element from an initial temperature to a first temperature; and maintain the temperature of the heating element constant at the first temperature for a duration of a first predetermined time period, wherein the first temperature is between 245 and 285 degrees Celsius.

**[0139]** Example Ex36: The system according to example Ex35, wherein the first time period has a duration of 40 seconds to 300 seconds, preferably 40 seconds to 150 seconds.

**[0140]** Example Ex37: The system according to example Ex35 or Ex36, wherein controlling the power during heating of the aerosol-forming substrate to form an aerosol for inhalation by a user further comprises adjusting the temperature of the heating element to a second temperature during a second predetermined time period, wherein the second predetermined time period is subsequent to the first predetermined time period.

**[0141]** Example Ex38: The system according to example Ex37, wherein the second temperature is different to the first temperature.

**[0142]** Example Ex39: The system according to example Ex36 or Ex37, wherein the second temperature is lower than the first temperature.

**[0143]** Example Ex40: The system according to example Ex39, wherein the second temperature is between 190 and 220 degrees Celsius.

**[0144]** Example Ex41: The system according to one of examples Ex37 to Ex39, wherein adjusting the temperature of the heating element to the second temperature during the second predetermined time period comprises two consecutive temperature steps.

**[0145]** Example Ex42: The system according to example Ex41, wherein a temperature of a first temperature step is lower than a temperature of a second temperature step.

**[0146]** Example Ex43: The system according to example Ex37 or Ex38, wherein adjusting the temperature of the heating element to a second temperature during the second predetermined time period comprises increasing the temperature of the heating element from the first temperature.

**[0147]** Example Ex44: The system according to one of examples Ex37 to Ex43, wherein a duration of the second predetermined time period is between 100 and 280 seconds.

**[0148]** Example Ex45: The system according to one of examples Ex37 to Ex40, wherein controlling the power during heating of the aerosol-forming substrate to form an aerosol for inhalation by a user further comprises adjusting the temperature of the heating element to a third temperature during a third predetermined time period, wherein the third predetermined time period is subsequent to the second predetermined time period.

**[0149]** Example Ex46: The system according to example Ex45, wherein the third temperature approximately corresponds to the first temperature.

**[0150]** Example Ex47: The system according to example Ex45 or Ex46, wherein a duration of the third predetermined time period is between 30 seconds and 120 seconds.

**[0151]** Example Ex48: The system according to one examples Ex37 to Ex47, wherein the aerosol-generating device further comprises a memory configured to store a plurality of temperature profiles, wherein each heating profile defines how to adjust the temperature of the heating element during each of the time periods, and wherein the controller is further configured to control the power during heating of the aerosol-forming substrate to form an aerosol for inhalation by a user based on a heating profile of the plurality of temperature profiles.

**[0152]** Example Ex49: The system according to example Ex48, wherein the controller is further configured to select the heating profile based on identifying the aerosol-generating article.

**[0153]** Example Ex50: The system according to one of example Ex37 to Ex47, wherein the aerosol-generating device further comprises a memory configured to store a plurality of temperature profiles, wherein each heating profile defines how to adjust the temperature of the heating element during the second predetermined time period, and wherein the controller is further configured to control the power during heating of the aerosol-forming substrate to form an aerosol for inhalation by a user based on a heating profile of the plurality of temperature profiles.

**[0154]** Example Ex51: The system according to example Ex50, wherein the controller is further configured to select the heating profile based on identifying the aerosol-generating article.

**[0155]** Example Ex52: The system according to one examples Ex35 to Ex51, wherein the aerosol-forming substrate further comprises the heating element, and wherein the heating system comprises an induction coil for inductively heating the heating element.

**[0156]** Example Ex53: The system according to one of examples Ex35 to Ex52, wherein the controller is further configured to: during a pre-heating time period before the first predetermined time period, control the power to increase the temperature of the heating element from an ambient temperature to the initial temperature.

**[0157]** Example Ex54: The system according to example Ex52 or Ex53, wherein the pre-heating time period has a duration between 10 and 20 seconds.

**[0158]** Example Ex55: The system according to one of examples Ex52 to Ex54, wherein the controller is further configured to calibrate the heating element subsequent to the pre-heating time period and before the first time period.

**[0159]** Example Ex56: The system according to one of examples Ex35 to Ex51, wherein the heating system comprises the heating element, the heating element being a resistive heating element.

**[0160]** Example Ex57: The system according to example Ex56, wherein the controller is further configured to: during a pre-heating time period before the first predetermined time period, control the power to increase the temperature of the heating element from an ambient temperature to the initial temperature.

**[0161]** Example Ex58: The system according to example Ex57, wherein the pre-heating time period has a duration between 10 and 20 seconds.

**[0162]** Example Ex59: The method according to one of examples Ex35 to Ex58, wherein the aerosol-forming substrate comprises a total aerosol-former content that is greater than 35 percent by weight.

[0163] Example Ex60: The method according to one of examples Ex35 to Ex59, wherein the aerosol-forming substrate comprises a total aerosol-former content that is greater than 40 percent by weight.

[0164] Example Ex61: The method according to one of examples Ex35 to Ex60, wherein the aerosol-forming substrate comprises a total aerosol-former content that is greater than 45 percent by weight.

[0165] Example Ex62: The system according to one of examples Ex35 to Ex61, wherein the aerosol-forming substrate comprises one or more aerosol formers selected from 1,3-butanediol, glycerin, 1,3-propanediol, propylene glycol, triethylene glycol, glycerol monoacetate, glycerol diacetate, glycerol triacetate, dimethyl dodecanedioate and dimethyl tetradecanedioate.

[0166] Example Ex63: The system according to one of examples Ex35 to Ex62, wherein the aerosol-forming substrate does not include tobacco.

[0167] Example Ex64: The system according to one of examples Ex35 to Ex63, wherein the aerosol-forming substrate further comprises nicotine.

[0168] Example Ex65: The system according to one of examples Ex35 to Ex64, wherein the aerosol-forming substrate further comprises one or more cellulose based agents and one or more carboxylic acids selected from fumaric acid, maleic acid and malic acid.

[0169] Example Ex66: The system according to example Ex65, wherein the aerosol-forming substrate has a total cellulose based agent content of at least 35 percent by weight and a total carboxylic acid content of at least 0.5 percent by weight.

[0170] Example Ex67: The system according to one of examples Ex35 to Ex66, wherein the aerosol-forming substrate comprises water.

[0171] Example Ex68: The system according to example Ex67, wherein the aerosol-forming substrate has a water content of between 5 percent by weight and 35 percent by weight.

[0172] Examples will now be further described with reference to the figures in which:

[0173] FIG. 1 is a schematic cross-sectional view of an aerosol-generating article comprising an aerosol-forming substrate and a susceptor;

[0174] FIG. 2 is a schematic cross-sectional view of an aerosol-generating system comprising the aerosol-generating article shown in FIG. 1 and an electrically operated aerosol-generating device comprising an inductor;

[0175] FIG. 3 is a graph of DC current vs. time illustrating the remotely detectable current changes that occur when a susceptor material undergoes a phase transition associated with its Curie point;

[0176] FIG. 4 is a graph of conductance vs time illustrating changes in conductance corresponding to changes of temperature of the susceptor during user operation of the aerosol-generating device;

[0177] FIG. 5 shows a schematic cross-sectional view of an aerosol-generating article according comprising an aerosol-forming substrate;

[0178] FIG. 6 shows a schematic cross-sectional view of an aerosol-generating system comprising the aerosol-generating article shown in FIG. 5 and an electrically-operated aerosol-generating device comprising a resistive heater for internally heating the aerosol-forming substrate from within the aerosol-forming substrate;

[0179] FIG. 7 is a graph of temperature vs. time illustrating part of a heating profile during user operation of the aerosol-generating device illustrated in FIG. 6;

[0180] FIG. 8 is a graph of temperature vs. time illustrating part of a heating profile during user operation of the aerosol-generating device illustrated in FIG. 2 or 6;

[0181] FIG. 9 is a graph of temperature vs. time illustrating part of a heating profile during user operation of the aerosol-generating device illustrated in FIG. 2 or 6;

[0182] FIG. 10 is a graph of temperature vs. time illustrating part of a heating profile during user operation of the aerosol-generating device illustrated in FIG. 2 or 6;

[0183] FIG. 11 is a graph of temperature vs. time illustrating part of a heating profile during user operation of the aerosol-generating device illustrated in FIG. 2 or 6;

[0184] FIG. 12 is a graph of temperature vs. time illustrating part of a heating profile during user operation of the aerosol-generating device illustrated in FIG. 2 or 6;

[0185] FIG. 13 is a graph of temperature vs. time illustrating part of a heating profile during user operation of the aerosol-generating device illustrated in FIG. 2 or 6; and

[0186] FIG. 14 is a flow diagram of a method of controlling aerosol production in an aerosol-generating device.

[0187] FIG. 1 is a schematic cross-sectional view of an aerosol-generating article 10 in which an aerosol-forming substrate of the aerosol-generating article is inductively heated from within; and FIG. 2 is a schematic cross-sectional view of an aerosol-generating system 100 comprising the aerosol-generating article 10 shown in FIG. 1 and an electrically operated aerosol-generating device 110 comprising an inductor.

[0188] The aerosol-generating article 10 shown in FIG. 1 comprises an aerosol-generating rod 12, a proximal section 14 located downstream of the aerosol-generating rod 12 and a distal section 16 located upstream of the aerosol-generating rod 12. As shown in FIG. 1, the aerosol-generating article 10 has an upstream or distal end 18 and a downstream or proximal end 20.

[0189] The proximal section 14 of the aerosol-generating article 10 comprises a support element 22 located immediately downstream of the aerosol-generating rod 12, an aerosol-cooling element 24 located immediately downstream of the support element 22, and a mouthpiece element 42 located immediately downstream of the aerosol-cooling element 24.

[0190] The support element 22 comprises a first hollow tubular segment 26. The first hollow tubular segment 26 is in the form of a hollow cylindrical tube made of cellulose acetate. The first hollow tubular segment 26 defines an internal cavity 28 that extends from an upstream end 30 of the first hollow tubular segment to a downstream end 32 of the first hollow tubular segment 20.

[0191] The aerosol-cooling element 24 comprises a second hollow tubular segment 34. The second hollow tubular segment 34 is in the form of a hollow cylindrical tube made of cellulose acetate. The second hollow tubular segment 34 defines an internal cavity 36 that extends from an upstream end 38 of the second hollow tubular segment to a downstream end 40 of the second hollow tubular segment 34.

[0192] As shown by the dashed vertical line in FIG. 1, the aerosol-generating article 10 comprises a ventilation zone 60 provided at a location along the second hollow tubular segment 34.

[0193] The mouthpiece element **42** is in the form of a cylindrical plug of low-density cellulose acetate.

[0194] The aerosol-generating rod **12** comprises an aerosol-forming substrate. The aerosol-forming substrate may be a solid or a gel. The aerosol-forming substrate comprises one or more aerosol formers, such as glycerin or propylene glycol. The total aerosol former content of the aerosol-forming substrate may be greater than 30 percent by weight. The total aerosol former content of the aerosol-forming substrate may be greater than 40 percent by weight. The total aerosol former content of the aerosol-forming substrate may be greater than 45 percent by weight. The aerosol-forming substrate may be a non-tobacco substrate that does not comprise a tobacco-containing material. Alternatively, the aerosol-forming substrate may comprise tobacco-containing material. In addition, the aerosol-forming substrate may comprise water. The aerosol-forming substrate may have a water content of between 5 percent by weight and 35 percent by weight.

[0195] The aerosol-forming substrate may comprise nicotine. The aerosol-forming substrate may comprise one or more cellulose based agents. The aerosol-forming substrate may comprise one or more carboxylic acids. The one or more carboxylic acids may be selected from fumaric acid, maleic acid, and malic acid.

[0196] The aerosol-forming substrate may be an aerosol-generating film and the aerosol-generating rod **12** may comprise a gathered crimped paper sheet coated with the solid aerosol-generating film.

[0197] The aerosol-generating article **10** comprises a heating element, such as a susceptor **44**, located within the aerosol-generating rod **12**. As shown in FIG. 2, the susceptor **44** is surrounded by the aerosol-forming substrate and extends along the longitudinal axis of the aerosol-generating rod **12** from an upstream end of the aerosol-generating rod **12** to a downstream end of the aerosol-generating rod **12**. The susceptor **44** is in direct contact with the aerosol-forming substrate.

[0198] The susceptor **44** may be in the form of a strip having a length of 12 millimeters, a width of 5 millimeters and a thickness of 60 micrometers. The susceptor **44** comprises at least two different materials. The susceptor **44** comprises at least two layers: a first layer of a first susceptor material disposed in physical contact with a second layer of a second susceptor material. The first susceptor material and the second susceptor material may each have a Curie temperature. In this case, the Curie temperature of the second susceptor material is lower than the Curie temperature of the first susceptor material. The first material may not have a Curie temperature. The first susceptor material may be aluminum, iron or stainless steel. The second susceptor material may be nickel or a nickel alloy.

[0199] The distal section **16** of the aerosol-generating article **10** comprises an upstream element **46** located immediately upstream of the aerosol-generating rod **12**.

[0200] The upstream element **46** is in the form of a cylindrical plug of cellulose acetate circumscribed by a stiff wrapper.

[0201] The aerosol-generating system **100** shown in FIG. 2 comprises the aerosol-generating article **10** shown in FIG. 1 and a handheld electrically operated aerosol-generating device **110**.

[0202] The aerosol-generating device **110** comprises a housing **112** defining a heating chamber **114** configured to receive a distal portion of the aerosol-generating article **10**.

[0203] The aerosol-generating device **110** comprises a power source (not shown) and a heating system (not shown). The heating system comprises a controller, a DC/AC converter and an inductor **116**. The power source may be a battery, such as a rechargeable lithium ion battery. The inductor **116** comprises an induction coil. The controller controls the supply of electrical power from the power source to the induction coil.

[0204] In use, a fluctuating or alternating electromagnetic field produced by the induction coil of the inductor **116** induces eddy currents in the susceptor **44** in the aerosol-generating rod **12** of the aerosol-generating article **10**, causing the susceptor **44** to heat up. Heat generated in the susceptor **44** is transferred to the aerosol-forming substrate in the aerosol-generating rod **12** of the aerosol-generating article **10** by conduction.

[0205] The user draws on the mouthpiece element **42** of the aerosol-generating article **10**. When a user draws on the mouthpiece element **42**, air is drawn into the aerosol-generating article **10** through the distal end **18**. The drawn air passes through the upstream element **46** to the aerosol-generating rod **12**. Heating of the aerosol-forming substrate releases volatile and semi-volatile compounds, which form an aerosol that is entrained in the drawn air as it flows through the aerosol-generating rod **12**. The drawn air and entrained aerosol pass through the intermediate hollow section **50** of the aerosol-generating article **10**, where they cool and condense. The cooled aerosol then passes through the mouthpiece element **42** of the aerosol-generating article **10** into the mouth of the user.

[0206] FIG. 3 illustrates the relationship between the DC current IDC drawn from the power source over time as the temperature of the susceptor **44** (indicated by the dashed line) increases. More specifically, FIG. 3 illustrates the remotely detectable DC current changes that occur when a susceptor material undergoes a phase transition associated with its Curie point. The DC current IDC drawn from the power source is measured at an input side of the DC/AC converter. For the purpose of this illustration, it may be assumed that the voltage VDC of the power source remains approximately constant.

[0207] As the susceptor **44** is inductively heated, the apparent resistance of the susceptor **44** increases. This increase in resistance is observed as a decrease in the DC current IDC drawn from the power source, which at constant voltage decreases as the temperature of the susceptor **44** increases. The high frequency alternating magnetic field provided by the inductor induces eddy currents in close proximity to the susceptor surface, an effect that is known as the skin effect. The resistance in the susceptor **44** depends in part on the electrical resistivity of the first susceptor material, the electrical resistivity of the second susceptor material and in part on the depth of the skin layer in each material available for induced eddy currents, and the resistivity is in turn temperature dependent.

[0208] As the second susceptor material reaches its Curie temperature, it loses its magnetic properties. This causes an increase in the skin layer available for eddy currents in the second susceptor material, which causes a decrease in the apparent resistance of the susceptor **44**. The result is a temporary increase in the detected DC current IDC. Then,

when the skin depth of the second susceptor material begins to increase, the resistance begins to fall. This is seen as the valley (the local minimum) **310** in FIG. 3.

[0209] As heating continues, the current continues to increase until the maximum skin depth is reached, which coincides with the point where the second susceptor material has lost its spontaneous magnetic properties. This point is called the Curie temperature and is seen as the hill (the local maximum) **320** in FIG. 3. At this point, the second susceptor material has undergone a phase change from a ferro-magnetic or ferri-magnetic state to a paramagnetic state. At this point, the susceptor **160** is at a known temperature (the Curie temperature, which is an intrinsic material-specific temperature).

[0210] If the inductive heating of the susceptor **44** continues after the Curie temperature has been reached, the eddy currents generated in the susceptor **44** will run against the resistance of the susceptor **44**, whereby Joule heating in the susceptor **44** will continue, and thereby the resistance will increase again (the resistance will have a polynomial dependence of the temperature, which for most metallic susceptor materials can be approximated to a third degree polynomial dependence for our purposes) and current will start falling again.

[0211] Therefore, the second susceptor material undergoes a reversible phase transition when heated through the (known) temperature range between the valley **310** and the hill **320** shown in FIG. 3. As can be seen from FIG. 3, the apparent resistance of the susceptor **44**, and hence the start and end of the reversible phase transition, can be remotely detected by monitoring at least the DC current IDC drawn from the power source. Although the DC supply voltage VDC is known, the DC supply voltage VDC may be monitored in addition to the DC current IDC. Therefore, apparent resistance of the susceptor **44**, and hence the start and end of the phase transition, can be remotely detected by monitoring a conductance value (where conductance is defined as the ratio of the DC current IDC to the DC supply voltage VDC) or a resistance value (where resistance is defined as the ratio of the DC supply voltage VDC to the DC current IDC). The DC current IDC, the conductance value and the resistance value may be referred to as power source parameters. As can be seen from FIG. 3, the apparent resistance of the susceptor **44** (and correspondingly the current IDC drawn from the power source) may vary with the temperature of the susceptor **44** in a strictly monotonic relationship between the start and end of the reversible phase transition, in other words between the valley **310** and the hill **320**. The strictly monotonic relationship allows for an unambiguous determination of the temperature of the susceptor **44** from a determination of the apparent resistance (R) or apparent conductance (1/R). This is because each determined value of the apparent resistance is representative of only one single value of the temperature, so that there is no ambiguity in the relationship. The monotonic relationship of the temperature of the susceptor **44** and the apparent resistance in the temperature range in which the second susceptor material undergoes the reversible phase transition allows for the determination and control of the temperature of the susceptor **44** and thus for the determination and control of the temperature of the aerosol-forming substrate.

[0212] The controller regulates the supply of power provided to the heating system based on a measurement of a power source parameter. The heating system may comprise

a current sensor (not shown) to measure the DC current IDC. The heating system may optionally comprise a voltage sensor (not shown) to measure the DC supply voltage VDC. The current sensor and the voltage sensor are located at an input side of the DC/AC converter. The DC current IDC and optionally the DC supply voltage VDC are provided by feedback channels to the controller to control the further supply of AC power PAC to the inductor **116**.

[0213] The controller may control the temperature of the susceptor **44** by maintaining the measured power source parameter value at a target value corresponding to a target operating temperature of the susceptor **44**. In other words, the controller adjusts the temperature of the susceptor **44** by controlling the power provided to the heating system to adjust the power source parameter value. In order to take advantage of the strictly monotonic relationship between the apparent resistance (or apparent conductance) of the susceptor **44** and the temperature of the susceptor **44**, during user operation for producing an aerosol, the power source parameter measured at the input side of the DC/AC converter is maintained between a first calibration value corresponding to a first calibration temperature and a second calibration value corresponding to a second calibration temperature. The second calibration temperature is the Curie temperature of the second susceptor material (the hill **320** in the current plot in FIG. 3). The first calibration temperature is a temperature greater than or equal to the temperature of the susceptor at which the skin depth of the second susceptor material begins to increase, leading to a temporary lowering of the resistance (the valley **310** in the current plot in FIG. 3). Thus, the first calibration temperature is a temperature greater than or equal to the temperature at maximum permeability of the second susceptor material. The first calibration temperature is at least 50 degrees Celsius lower than the second calibration temperature. At least the second calibration value is determined by calibration of the susceptor **44**, as will be described in more detail below. The first calibration value and the second calibration value may be stored as calibration values in a memory of the aerosol-generating device **110**.

[0214] Since the power source parameter will have a polynomial dependence on the temperature, the power source parameter will behave in a nonlinear manner as a function of temperature. However, the first and the second calibration values are chosen so that this dependence may be approximated as being linear between the first calibration value and the second calibration value because the difference between the first and the second calibration values is small, and the first and the second calibration values are in the upper part of the operational temperature range. Therefore, to adjust the temperature to a target operating temperature, the power supply parameter is regulated according to the first calibration value and the second calibration value, through linear equations.

[0215] For example, if the first and the second calibration values are conductance values, the target conductance value, GR, corresponding to the target operating temperature may be given by:

$$G_R = G_{Lower} + (x + \Delta G)$$

[0216] where  $\Delta G$  is the difference between the first conductance value and the second conductance value and  $x$  is a percentage of  $\Delta G$ . Thus, the controller adjusts the power source parameter value based on the power source parameter value measured at the valley 310 during calibration and the difference between the power source parameter value measured at the hill 320 and the valley 310 during calibration.

[0217] The first and second calibration values are obtained by performing a calibration process. The controller is programmed to perform the calibration process each time the user operates the aerosol-generating device 110. For example, the controller may be configured to enter a calibration mode for performing the calibration process when the user switches on the aerosol-generating device 110. The controller may be programmed to enter the calibration mode each time the user inserts an aerosol-generating article 10 into an aerosol-generating device 110. Thus, the calibration process is performed during a first heating phase of the aerosol-generating device, before the main phase in which the user inhales the generated aerosol.

[0218] During the calibration process, the controller controls the DC/AC converter to continuously or continually supply power to the inductor 116 in order to heat the susceptor 44. The controller monitors the power source parameter by measuring the current IDC drawn by the power source and, optionally the power source voltage VDC. As the susceptor 44 is heated, the measured current decreases until the valley (the first turning point) 310 is reached and the current IDC begins to increase. This first turning point 310 corresponds to a local minimum conductance or current value (a local maximum resistance value). The controller may record the power source parameter value at the first turning point 310 as the first calibration value.

[0219] The temperature of the susceptor 44 at the first calibration value is the first calibration temperature. As the controller continues to control the power provided by the DC/AC converter to the inductor 116, the controller continues to monitor the power supply parameter until the hill (a second turning point) 320 is reached. The second turning point corresponds to a maximum current (corresponding to the Curie temperature of the second susceptor material) before the measured current begins to decrease. This second turning point 320 corresponds to a local maximum conductance or current value (a local minimum resistance value). The control circuitry records the power supply parameter value at the second turning point 320 as the second calibration value. The temperature of the susceptor 44 at the second calibration value is the second calibration temperature. When the second turning point 320 is detected, the controller controls the DC/AC converter to interrupt provision of power to the inductor 116, resulting in a decrease in susceptor 44 temperature and a corresponding decrease in measured current.

[0220] Due to the shape of the graph 300, this process of continuously heating the susceptor 44 to obtain the first calibration value and the second calibration value may be repeated at least once during the calibration mode. Preferably, controller regulates the power based on the power source parameter values obtained from minimum repetition of the calibration process, this being more reliable because the heat will have had more time to distribute within the aerosol-forming substrate and the susceptor 44.

[0221] The controller is configured to detect the turning points 310 and 320 by measuring a sequence of power

source parameter values. With reference to FIG. 3, the sequence of measured power source parameter values will form a curve, with each value being greater than or less than the previous value. The controller is configured to measure the calibration value at the point where the curve begins to flatten. In other words, the controller records the calibration values when the difference between consecutive power supply parameter values is below a predetermined threshold value.

[0222] In order to further improve the reliability of the calibration process, the controller may be optionally programmed to perform a pre-heating process before the calibration process. For example, if the aerosol-forming substrate is particularly dry or in similar conditions, the calibration process may be performed before heat has spread within the aerosol-forming substrate, reducing the reliability of the calibration values. If the aerosol-forming substrate were humid, the susceptor 44 takes more time to reach the valley temperature (due to water content in the aerosol-forming substrate).

[0223] To perform the pre-heating process, the controller is configured to continuously provide power to the inductor 116. As described above with respect to FIG. 3, the measured current starts decreasing with increasing susceptor 44 temperature until a turning point 310 corresponding to minimum measured current (conductance) is reached. At this stage, the controller is configured to wait for a predetermined period of time to allow the susceptor 44 to cool before continuing heating. The controller therefore controls the DC/AC converter to interrupt provision of power to the inductor 116. After the predetermined period of time, the controller controls the DC/AC converter to provide power until the turning point 310 corresponding to the minimum measured current is reached again. At this point, the controller controls the DC/AC converter to interrupt provision of power to the inductor 116 again. The controller again waits for the same predetermined period of time to allow the susceptor 44 to cool before continuing heating. This heating and cooling of the susceptor 44 is repeated for a predetermined duration of time of the pre-heating process 410. The predetermined duration of the pre-heating process is between 10 and 20 seconds, preferably 11 seconds. The duration of the calibration process is between 10 and 20 seconds. If the aerosol-forming substrate is dry, the first current minimum of the pre-heating process is reached within the pre-determined period of time and the interruption of power will be repeated until the end of the predetermined time period. If the aerosol-forming substrate has a higher moisture content, the first current minimum of the pre-heating process 410 will be reached towards the end of the pre-determined time period. Therefore, performing the pre-heating process for a predetermined duration ensures that, whatever the physical condition of the aerosol-forming substrate, the time is sufficient for the aerosol-forming substrate to reach the minimum operating temperature, in order to be ready to feed continuous power and reach the first maximum. This allows a calibration as early as possible, but still without risking that, the aerosol-forming substrate would not have reached the first calibration temperature beforehand.

[0224] In particular, aerosol-forming substrates comprising a higher aerosol-former content (for example, greater than 30 percent by weight) and a higher water content (for example greater than 5 percent by weight) will have a higher

thermal inertia. Therefore, the pre-heating process ensures that the minimum operating temperature is reached before calibration.

[0225] The pre-heating process may be performed in response to receiving a user input, for example user activation of the aerosol-generating device 110. Additionally or alternatively, the control circuitry may be configured to detect the presence of an aerosol-generating article 10 in the aerosol-generating device 110 and the pre-heating process may be performed in response to detecting the presence of the aerosol-generating article 10 within the heating chamber of the aerosol-generating device 110.

[0226] FIG. 4 is a graph of conductance against time showing a heating profile of the susceptor 44. The graph illustrates five stages of the heating profile: the pre-heating process performed during pre-heating mode 410, the calibration process performed during calibration mode 420, and the main phase in which the user inhales the aerosol, comprising heating modes 430, 440 and 450. Although FIG. 4 is illustrated as a graph of conductance against time, it is to be understood that the controller may be configured to control the heating of the susceptor 44 during each stage of the heating profile based on any measured power source parameter, such as resistance or current as described above.

[0227] Once the calibration process 420 is complete, the controller is configured to interrupt the provision of power provided to the heating system to allow the susceptor to cool to an initial temperature. Once it is detected that the susceptor temperature is at the initial temperature, or after the susceptor temperature has been at the initial temperature for a predetermined period of time, the controller is configured to control the power provided to the heating system in order to increase the temperature of the susceptor 44 from an initial temperature to a first temperature. Specifically, the controller controls the power provided to the heating system in order to adjust the conductance to correspond to a first operating temperature of the susceptor 44 for a first predetermined time period. In an example, the conductance during the first heating mode 430 is  $0.75 \times \Delta G$ , in other words 75 percent of the difference in the measured conductance between the hill 320 and the valley 310.

[0228] The first operating temperature is chosen so that desired volatile compounds are vaporized from the substrate but undesirable compounds, which are vaporized or generated at higher temperatures, are not released. Further, heating the susceptor 44 to the maximum operating temperature of the susceptor 44 immediately after the calibration process 420 improves the amount of vaporized desired volatile compounds, thereby providing improved delivery to the user from the first puff. The first operating temperature of the susceptor 44 may be a maximum operating temperature of the susceptor 44.

[0229] FIG. 5 is a schematic cross-sectional view of an aerosol-generating article 500; and

[0230] FIG. 6 is a schematic cross-sectional view of an aerosol-generating system 600 comprising the aerosol-generating article 500 of FIG. 5 and an electrically-operated aerosol-generating device 610 comprising a resistive heater configured to heat the aerosol-generating article 500 from within the aerosol-generating article 500.

[0231] The aerosol-generating article 500 has generally the same structure as the aerosol-generating article 10 described above with respect to FIG. 1, where like elements are indicated by like reference signs. Note, however, that the

aerosol-generating article 500 does not comprise the susceptor 44. In addition, the aerosol-generating article does not comprise upstream element 46.

[0232] The aerosol-generating device 610 comprises a heating chamber 630 for receiving the aerosol-generating article 500. A heating element 620 is located within the heating chamber and positioned to engage with the distal end 18 of the aerosol-generating article 500. The heating element 620 is an electrically resistive heating element shaped in the form of a blade terminating in a point. The heating element 620 may be formed from a ceramic substrate with one or more resistive heating tracks, formed from platinum or another suitable material, deposited on one or both sides of the blade. Alternatively, the heating element 620 may be one or more heating needles or rods that run through the center of the aerosol-forming substrate 510. Other alternatives include a heating wire or filament, for example a Ni—Cr (Nickel-Chromium), platinum, tungsten or alloy wire or a heating plate. Optionally, the heating element 620 may be deposited in or on a rigid carrier material. For example, the electrically resistive heating element 620 may be formed using a metal having a defined relationship between temperature and resistivity. In such an exemplary device, the metal may be formed as a track on a suitable insulating material, such as ceramic material, and then coated by another insulating material, such as a glass. Heaters formed in this manner may be used to both heat and monitor the temperature of the heating elements during operation.

[0233] As the aerosol-generating article 500 is pushed onto the point of the heating element 620, by applying a force to the aerosol-generating article 500, the heating element 620 penetrates into aerosol-forming substrate of the aerosol-generating rod 12. Further penetration is prevented as the distal end 18 of the aerosol-generating article 500 abuts an end wall 640 of the heating chamber 630, which acts as a stop.

[0234] When the aerosol-generating article 500 is properly engaged with the aerosol-generating device 610, the heating element 620 is located within the aerosol-forming substrate in contact with aerosol-forming substrate. The heating element 620 heats the aerosol-forming substrate by means of conduction.

[0235] The aerosol-generating device 610 comprises a power source (not shown) and a heating system (not shown) electrically coupled to the power source. The heating system comprises a controller and the heating element 620. The power source may be a battery, such as a rechargeable lithium ion battery. The power source is configured to supply power to the heating system in order to heat the heating element 620.

[0236] The controller obtains an indication of the temperature of the heating element 620 (for example the electrical resistance of the heating element) by measuring the electrical resistance of the heating element 620. The indication of the temperature is used to adjust the current supplied to the heating element 620 in order to maintain the heating element 620 close to a target temperature. In other words, the controller adjusts the temperature of the heating element by adjusting the current supplied to the heating element 620.

[0237] This scheme relies on three or more temperature calibration points at which the resistance of the heating element 620 is measured. For temperatures intermediate the

calibration points, the resistance values are interpolated from the values at the calibration points. The calibration point temperatures are chosen to cover the expected temperature range of the heating element 620 during operation. The calibration of the heating element 620 to obtain the calibration points may be performed at manufacture and the calibration points stored in a memory of the controller.

[0238] When the heating element 620 is heated, the aerosol-forming substrate is heated and volatile substances are formed. As a user draws on the proximal end 20 of the aerosol-generating article 500, air is drawn into the aerosol-generating article 500 and the volatile substances condense to form an inhalable aerosol. This aerosol passes through the proximal end 20 of the aerosol-generating article 500 and into the user's mouth.

[0239] FIG. 7 is a graph of heating element temperature against time, showing part of a heating profile for the aerosol-generating device using resistive heating described above with respect to FIG. 6. During phase 710, the heating element is at an initial temperature. Phase 710 may be a pre-heating phase in which the controller is programmed to pre-heat the heating element to a predetermined initial temperature for a predetermined duration of time.

[0240] The pre-heating phase ensures that, whatever the physical condition of the aerosol-forming substrate (dry or humid, for example), the time duration of the pre-heating phase is sufficient for the aerosol-forming substrate to reach a minimum operating temperature, in order to be ready to feed continuous power and reach the first operating temperature as quickly as possible for generating sufficient aerosol to be inhaled by the user.

[0241] In particular, aerosol-forming substrates comprising a non-tobacco material will have a higher thermal inertia than a tobacco-based aerosol-forming substrate because the non-tobacco aerosol-forming substrate comprises a higher aerosol-former content (for example, greater than 30 percent by weight) and a higher water content (for example greater than 5 percent by weight). Therefore, in the case of a non-tobacco aerosol-forming substrate having a higher moisture content, the pre-heating process ensures that a minimum operating temperature is reached before the main phase. The duration of the pre-heating mode is between 10 and 20 seconds, preferably 11 seconds.

[0242] Subsequent to the pre-heating phase, the controller is configured to enter a first heating mode 720 of the main phase. The first heating mode may be entered in response to a timer indicating that the predetermined duration of the pre-heating phase 710 has elapsed, user actuation of the aerosol-generating device, or after detection of a user puff. During the first heating mode 720, the controller rapidly increases the temperature of the heating element from the initial temperature to a first temperature.

[0243] The first temperature is chosen so that desired volatile compounds are vaporized from the substrate but undesirable compounds, which are vaporized or generated at higher temperatures, are not released. Further, rapidly heating the heating element to the first temperature of the heating element improves the amount of vaporized desired volatile compounds, thereby providing improved delivery to the user from the first puff. The first temperature may be a maximum operating temperature of the heating element.

[0244] During phases 720, 730 and 740, the aerosol-generating device generates an aerosol for inhalation by the user and the controller is configured to control the power

provided to the heating element in order to adjust the temperature of the heating element in accordance with a heating profile.

[0245] One or more heating profiles may be stored on a memory of the controller described in relation to FIGS. 1, 2, and 6. The controller may be configured to select a heating profile during user operation of the device to generate an aerosol. For example, the aerosol-generating device may comprise a means for identifying the aerosol-generating article or the aerosol-forming substrate and may select a heating profile based on the result of the identification.

[0246] FIGS. 8 to 13 are graphs of heating element temperature against time showing exemplary heating profiles of the heating element during the main phase of heating of the aerosol-forming substrate to form an aerosol for inhalation by a user. The illustrated heating profiles define temperature values for each heating mode and a corresponding duration of each heating mode. However, it is to be understood that the heating profiles may comprise more than three heating modes.

[0247] Each of the heating profiles in FIGS. 8 to 13 show a shaded area 810, 910, 1010, 1110, 1210 and 1310. This shaded area corresponds to the calibration and optional pre-heating phases of the aerosol-generating device having an inductive heating system (FIG. 2) or the pre-heating phase of the aerosol-generating device having a resistive heating system (FIG. 6).

[0248] Each of the heating profiles in FIGS. 8 to 13 illustrate that the temperature of the heating element increases from an initial temperature (not shown) to a first temperature in the first heating mode 820, 920, 1020, 1120, 1220, 1320. The controller may be configured to enter the first heating mode 820, 920, 1020, 1120, 1220, 1320 in response to a user actuation of the aerosol-generating device, or detection of a user puff. The temperature remains constant at the first temperature for the duration of the first time period. The initial temperature is greater than ambient temperature and is between 140 and 170 degrees Celsius. In the case of inductive heating, the initial temperature may be a temperature reached during the calibration process 420. For example, after reaching maximum conductance during the calibration process at the hill 320, the heating element 44 may be allowed to cool to a temperature between the first and the second calibration temperatures. The temperature to which the heating element 44 cools may be the initial temperature. In the case of resistive heating, the initial temperature may be the pre-heating temperature of the heating element 620.

[0249] The first temperature may be between 245 and 285 degrees Celsius. As discussed above, heating the heating element to the first temperature of the heating element in the first heating mode 820, 920, 1020, 1120, 1220, 1320, the thermal inertia of the aerosol-forming substrate is overcome and the amount of vaporized desired volatile compounds in the aerosol inhaled by the user, such as nicotine and the aerosol former, is improved from the first puff.

[0250] After a first predetermined time period, the controller enters a second heating mode 830, 930, 1030, 1130, 1230, 1330. In the second heating mode, the controller adjusts the temperature of the heating element to one or more second temperatures during a second predetermined time period. The one or more second temperatures may be between 190 and 220 degrees Celsius.

[0251] In the second heating mode **830, 930, 1030, 1130, 1230, 1330**, the controller may adjust the temperature of the heating element to approximately correspond to the first temperature, as shown in FIG. 8.

[0252] In the second heating mode **830, 930, 1030, 1130, 1230, 1330**, the controller may adjust the temperature of the heating element to be lower than the first temperature, as shown in FIGS. 10, 11, 12 and 13. At the end of the first heating mode **820, 920, 1020, 1120, 1220, 1320**, heat will have spread throughout the aerosol-forming substrate. Lowering the temperature of the heating element in the second heating mode therefore enables the amount of vaporized desired volatile compounds in the aerosol inhaled by the user to remain consistent with the amount in the first heating mode **820, 920, 1020, 1120, 1220, 1320**, thereby providing the same sensorial experience for the user.

[0253] In the second heating mode **830, 930, 1030, 1130, 1230, 1330**, the controller may adjust the temperature of the heating element to be higher than the first temperature, as shown in FIG. 14.

[0254] In the second heating mode **830, 930, 1030, 1130, 1230, 1330**, the controller may adjust the temperature of the heating element to a second temperature for the duration of the second time period, as shown in FIGS. 8, 9 and 13. Alternatively, in the second heating mode, the controller may adjust the temperature of the heating element in a plurality of consecutive temperature steps. For example, FIG. 10 shows two temperature steps having the same time duration, where the temperature of the heating element is lower during the first temperature step than during the second temperature step. FIG. 11 shows two temperature steps, where the temperature of the heating element is lower during the first temperature step than during the second temperature step, and where the duration of the first temperature step is shorter than the duration of the second temperature step.

[0255] In the third heating mode **840, 940, 1040, 1140, 1240, 1340**, the controller is configured to adjust the temperature of the heating element to a third temperature. The temperature of the heating element remains constant at the third temperature for the predetermined duration of the third time period. As shown in FIGS. 8 to 13, the third temperature approximately corresponds to the first temperature. At this stage of the usage session, the desired volatile compounds of the aerosol-forming substrate will have become depleted. Therefore, increasing the temperature of the heating element to approximately the first temperature enables the amount of vaporized desired volatile compounds in the aerosol inhaled by the user to remain consistent with the amount in the first and second heating modes.

[0256] Each of the predetermined time periods may be equal in length or different in length. For example, the first predetermined time period may be shorter than the subsequent second predetermined time period, for example as shown in FIGS. 8, 9, 10 and 12. Additionally or alternatively, the first predetermined time period may be shorter than the third predetermined time period, for example as shown in FIGS. 9 and 10. The second predetermined time period may be longer than at least one of the first predetermined time period and the third predetermined time period, as shown for example in FIGS. 8 to 13. The first predetermined time period and the third predetermined time period may have the time duration, for example as illustrated in FIG. 12.

[0257] The length of the first predetermined time period may be between 40 seconds and 150 seconds. The length of the second predetermined time period may be between 100 and 280 seconds. The length of the third predetermined time period may be between 30 seconds and 120 seconds.

[0258] The length of the first predetermined time period is chosen so that the aerosol-forming substrate can provide good delivery of volatilized desired compounds in the aerosol. The first predetermined time period being shorter than at least the second predetermined time period ensures good aerosol delivery to the user, while ensuring consistency in the user experience throughout the usage session.

[0259] The length of the second predetermined time period being longer than at least the first predetermined time period, in particular when the second temperature is lower than the first temperature, provides for improved control of the amount of vaporized desired volatile compounds in the aerosol inhaled by the user, thereby providing a consistent user experience for as long as possible throughout the usage session.

[0260] FIG. 14 is a flow diagram illustrating a method of controlling aerosol production in one of the aerosol-generating devices by heating a heating article inserted into the heating chamber of the aerosol-generating device as described above.

[0261] The method begins at step **1410** when the user actuates heating of the heating element as described above. For example, the user may press one or more buttons of the aerosol-generating device to begin the heating of the heating element. Additionally or alternatively, the user may insert an aerosol-generating article into the heating chamber of the aerosol-generating device to begin the heating of the heating element.

[0262] The method then proceeds to step **1420**, where the controller controls the power provided to the heating system to increase the temperature of the heating element from an ambient temperature to an initial temperature. During step **1420**, the controller is in the pre-heating mode and maintains the temperature of the heating element at the initial temperature for a predetermined time period.

[0263] When the aerosol-generating device heats the heating element by means of induction (the aerosol-generating device of FIG. 2), the pre-heating mode is followed by a calibration process at step **1430** to obtain the first and the second calibration values. The controller uses the first and the second calibration values to adjust the temperature of the susceptor as described above.

[0264] At step **1440**, subsequent to step **1420** for the aerosol-generating devices that use resistive heating and subsequent to step **1430** for the aerosol-generating device that uses inductive heating, the controller enters a first heating mode. In the first heating mode, the controller adjusts the temperature of the heating element to increase the temperature from the initial temperature to a first temperature. The first temperature is maintained for a first predetermined time period.

[0265] At the end of the first predetermined time period, the controller enters a second heating mode at step **1450**. In the second heating mode, the controller adjusts the temperature of the heating element to a second temperature. The second temperature may be maintained for a second predetermined time period. Alternatively, the second temperature may be a first step of a plurality of temperature steps, each having a predefined duration, where the sum of the pre-

defined duration of each temperature step is the duration of the second predetermined time period of the second heating mode. The second temperature may be lower than, approximately equal to, or greater than the first temperature.

[0266] At the end of the second predetermined time period, the controller enters a third heating mode at step 1460. In the third heating mode, the controller adjusts the temperature of the heating element to a third temperature. The third temperature is maintained for a third predetermined time period. The third temperature is approximately equal to the first temperature and is maintained constant for the duration of the third time period.

[0267] It is to be understood that the Figures are for illustrative purposes and are not shown to scale. Moreover, it will be appreciated that the aerosol-generating articles and the aerosol-generating devices shown in the Figures and described in detail above may have additional elements to those discussed. Likewise, an aerosol-generating article or an aerosol-generating device according to the embodiments discussed here may have fewer elements. Moreover, it will now be apparent to one of ordinary skill in the art that various dimensions for the elements discussed in relation to the various embodiments discussed here are merely exemplary, and that suitable alternative dimensions for the various elements may be chosen.

[0268] For the purpose of the present description and of the appended claims, except where otherwise indicated, all numbers expressing amounts, quantities, percentages, and so forth, are to be understood as being modified in all instances by the term “about”. Also, all ranges include the maximum and minimum points disclosed and include any intermediate ranges therein, which may or may not be specifically enumerated herein. In this context, therefore, a number A is understood as  $A \pm 10\%$  of A. Within this context, a number A may be considered to include numerical values that are within general standard error for the measurement of the property that the number A modifies. The number A, in some instances as used in the appended claims, may deviate by the percentages enumerated above provided that the amount by which A deviates does not materially affect the basic and novel characteristic(s) of the claimed invention. Also, all ranges include the maximum and minimum points disclosed and include any intermediate ranges therein, which may or may not be specifically enumerated herein. Further, the expression a number A “approximately corresponds to” a number B in the context of this invention, is to be understood as the number A is equal to  $B \pm 10\%$  of B.

1.-15. (canceled)

16. A method of controlling aerosol production in an aerosol-generating device, the aerosol-generating device comprising: a heating chamber configured to at least partially receive an aerosol-generating article comprising an aerosol-forming substrate; a heating system associated with a heating element that is configured to internally heat the aerosol-forming substrate from within the aerosol-forming substrate; and a power source configured to provide power to the heating system, the method comprising:

receiving, by the heating chamber, the aerosol-generating article, wherein the aerosol-forming substrate has a total aerosol former content greater than 30 percent by weight, and wherein the aerosol-forming substrate is a solid or a gel;

heating the aerosol-forming substrate to form an aerosol for inhalation by a user by controlling the power to:

increase a temperature of the heating element from an initial temperature to a first temperature, and maintain the temperature of the heating element constant at the first temperature for a duration of a first predetermined time period, wherein the first temperature is between 245 degrees Celsius and 285 degrees Celsius;

controlling the power to, during a pre-heating time period before the first predetermined time period, increase the temperature of the heating element from an ambient temperature to the initial temperature; and calibrating the heating element subsequent to the pre-heating time period and before the first predetermined time period.

17. The method according to claim 16, wherein controlling the power further comprises adjusting the temperature of the heating element to a second temperature during a second predetermined time period,

wherein the second predetermined time period is subsequent to the first predetermined time period, and wherein the second temperature is lower than the first temperature.

18. The method according to claim 17, wherein adjusting the temperature of the heating element to the second temperature during the second time period comprises two consecutive temperature steps.

19. The method according to claim 18, wherein a temperature of a first temperature step is lower than a temperature of a second temperature step.

20. The method according to claim 17, wherein controlling the power further comprises adjusting the temperature of the heating element to a third temperature during a third predetermined time period, wherein the third predetermined time period is subsequent to the second predetermined time period, and wherein the third temperature approximately corresponds to the first temperature.

21. A system, comprising:  
an aerosol-generating article comprising an aerosol-forming substrate having a total aerosol former content greater than or equal to 30 percent by weight, wherein the aerosol-forming substrate is a solid or a gel; and  
an aerosol-generating device, comprising:

a heating chamber configured to at least partially receive the aerosol-generating article,

a heating system associated with a heating element that is configured to internally heat the aerosol-forming substrate from within the aerosol-forming substrate, a power source configured to provide power to the heating system, and

a controller configured to:

control the power during heating of the aerosol-forming substrate to form an aerosol for inhalation by a user to:

increase a temperature of the heating element from an initial temperature to a first temperature, and maintain the temperature of the heating element constant at the first temperature for a duration of a first predetermined time period, wherein the first temperature is between 245 degrees Celsius and 285 degrees Celsius,

during a pre-heating time period before the first predetermined time period, increase the tempera-

ture of the heating element from an ambient temperature to the initial temperature, and calibrate the heating element subsequent to the pre-heating time period and before the first time period.

**22.** The system according to claim **21**,

wherein controlling the power during heating of the aerosol-forming substrate to form an aerosol for inhalation by a user further comprises adjusting the temperature of the heating element to a second temperature during a second predetermined time period,

wherein the second predetermined time period is subsequent to the first predetermined time period, and wherein the second temperature is lower than the first temperature.

**23.** The system according to claim **22**,

wherein controlling the power during heating of the aerosol-forming substrate to form an aerosol for inhalation by a user further comprises adjusting the temperature of the heating element to a third temperature during a third predetermined time period,

wherein the third predetermined time period is subsequent to the second predetermined time period, and wherein the third temperature approximately corresponds to the first temperature.

**24.** The system according to claim **21**,

wherein the aerosol-forming substrate further comprises the heating element, and

wherein the heating system comprises an induction coil configured to inductively heat the heating element.

**25.** The system according to claim **24**, wherein the controller is further configured to calibrate the heating element subsequent to the pre-heating time period and before the first time period.

**26.** The system according to claim **23**, wherein the aerosol-forming substrate does not include tobacco.

**27.** The system according to claim **21**,

wherein the aerosol-forming substrate comprises water, and

wherein the aerosol-forming substrate has a water content of between 5 percent by weight and 35 percent by weight.

\* \* \* \* \*