



(86) **Date de dépôt PCT/PCT Filing Date:** 2013/05/30
 (87) **Date publication PCT/PCT Publication Date:** 2013/12/19
 (45) **Date de délivrance/Issue Date:** 2016/08/23
 (85) **Entrée phase nationale/National Entry:** 2014/12/11
 (86) **N° demande PCT/PCT Application No.:** CN 2013/076440
 (87) **N° publication PCT/PCT Publication No.:** 2013/185538
 (30) **Priorité/Priority:** 2012/06/11 (CN201210188436.9)

(51) **Cl.Int./Int.Cl. C25C 3/08** (2006.01),
C25C 3/12 (2006.01), **C25C 3/18** (2006.01)
 (72) **Inventeurs/Inventors:**
SUN, SONGTAO, CN;
FANG, YULIN, CN
 (73) **Propriétaire/Owner:**
INNER MONGOLIA UNITED INDUSTRIAL CO., LTD.,
CN
 (74) **Agent:** BLAKE, CASSELS & GRAYDON LLP

(54) **Titre : RESERVOIR D'ELECTROLYSE UTILISE POUR L'ELECTROLYSE D'ALUMINIUM ET PROCEDE D'ELECTROLYSE
UTILISANT L'ELECTROLYSEUR**

(54) **Title: ELECTROLYTIC CELL FOR ALUMINUM ELECTROLYSIS AND ELECTROLYSIS PROCESS USING ELECTROLYTIC
CELL**

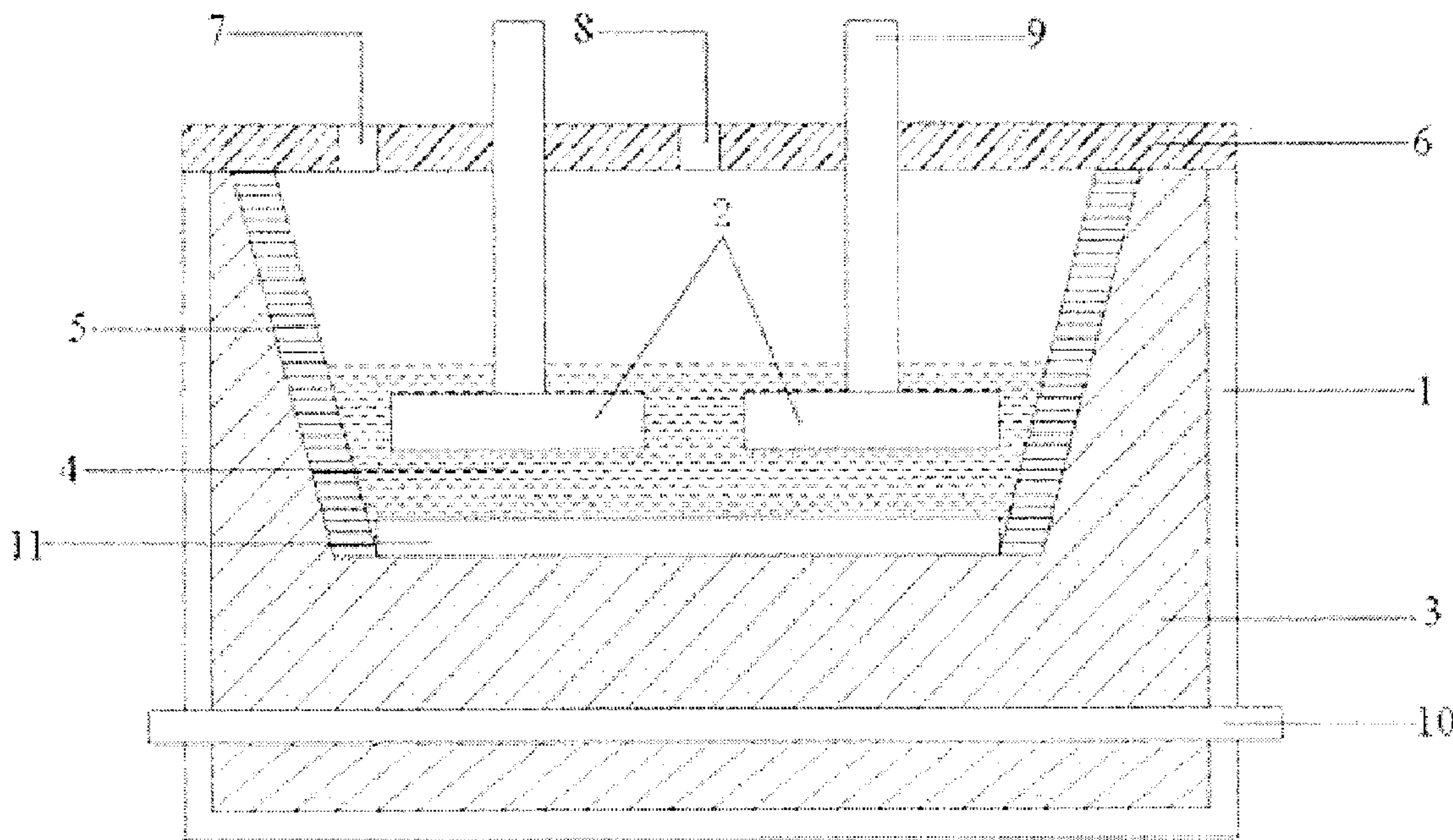

(57) **Abrégé/Abstract:**

An electrolysis tank used for aluminum electrolysis, comprising a tank body, an anode and a cathode arranged within the tank body, also an electrolyte accommodated within the tank body, where at least a part of the anode is submerged in the electrolyte. The anode is arranged above the tank body. The cathode is arranged at the tank bottom and is covered by a certain amount of liquid aluminum. The electrolyte is provided between the anode and the cathode. The electrolyte covers the liquid aluminum. The tank body has arranged on an inner sidewall thereof an insulation layer for use in separating oxygen or the electrolyte from a carbon block. The tank is characterized in that: the constituents of the anode comprise Fe, Cu, Ni, and Sn, where Fe and Cu are the main constituents; the electrolyte consists of 30 to 38 wt% of NaF, 49 to 60 wt% of AlF₃, 1 to 5 wt% of LiF, 1 to 6 wt% of KF, and 3 to 6 wt% of Al₂O₃, where the molar ratio of NaF to AlF₃ is between 1.0 and 1.52. The electrolysis tank is applicable in industrialized production of electrolyzed aluminum.

1

Abstract

2 An electrolysis tank used for aluminum electrolysis, comprising a tank body, an anode and a
3 cathode arranged within the tank body, also an electrolyte accommodated within the tank body,
4 where at least a part of the anode is submerged in the electrolyte. The anode is arranged above
5 the tank body. The cathode is arranged at the tank bottom and is covered by a certain amount
6 of liquid aluminum. The electrolyte is provided between the anode and the cathode. The
7 electrolyte covers the liquid aluminum. The tank body has arranged on an inner sidewall thereof
8 an insulation layer for use in separating oxygen or the electrolyte from a carbon block. The tank
9 is characterized in that: the constituents of the anode comprise Fe, Cu, Ni, and Sn, where Fe
10 and Cu are the main constituents; the electrolyte consists of 30 to 38 wt% of NaF, 49 to 60 wt%
11 of AlF_3 , 1 to 5 wt% of LiF, 1 to 6 wt% of KF, and 3 to 6 wt% of Al_2O_3 , where the molar ratio of
12 NaF to AlF_3 is between 1.0 and 1.52. The electrolysis tank is applicable in industrialized
13 production of electrolyzed aluminum.

1 **ELECTROLYTIC CELL FOR ALUMINUM ELECTROLYSIS AND ELECTROLYSIS PROCESS**
2 **USING ELECTROLYTIC CELL**

3 **Field of the Invention**

4 The present invention relates to an electrolytic cell for aluminum electrolysis and an electrolysis
5 process using the electrolytic cell, belonging to non-ferrous metal smelting industry.

6 **Background of the Invention**

7 In aluminum electrolysis industry, a traditional Hall-Heroult molten salt aluminum electrolysis
8 process is typically adopted to perform electrolysis on the molten salts of cryolite-alumina in a
9 prebaked carbon anode electrolytic cell typically by adopting, that is, cryolite Na_3AlF_6 fluoride
10 salt melt is taken as flux, Al_2O_3 is dissolved in the fluoride salt, a carbon body is taken as an
11 anode and vertically inserted into the electrolytic cell, a carbon body with aluminum liquid
12 covering the bottom of the electrolytic cell is taken as a cathode, electrochemical reaction is
13 carried out on the anode and cathode of the electrolytic cell at a high temperature ranging from
14 940 to 960°C after a strong direct current is introduced, and the resultant aluminum liquid
15 product covers the cathode at the bottom of the electrolytic cell. Due to high electrolysis
16 temperature, the traditional aluminum electrolysis process has such characteristics as large
17 volatilization amount of electrolyte, large oxidization loss of a carbon anode, large energy
18 consumption and poor working environment.

19 In the prior art, in order to lower electrolysis temperature, a low temperature molten salt system
20 for aluminum electrolysis is disclosed in Chinese patent document CN101671835A, the molten
21 salt composition of the system includes AlF_3 , Al_2O_3 and one or more salts selected from the
22 group consisting of KF , NaF , MgF_2 , CaF_2 , NaCl , LiF , and BaF_2 , and the electrolysis temperature
23 of the electrolyte can be lowered to be within a wide area from 680 to 900°C for the purpose of
24 operations.

25 Addition of NaCl to the aforementioned electrolyte aims at lowering the liquidus temperature of
26 the electrolyte, however, NaCl will lead to corrosion to metal parts like electrolytic cell
27 accessories at the aforementioned electrolysis temperature, furthermore, NaCl is extremely
28 liable to volatilization in the electrolysis process so as to form HCl toxic gas, so its application is
29 difficult; in addition to addition of NaCl , decrease of the molar ratio of NaF to AlF_3 can also lower
30 the liquidus temperature of the electrolyte in light of common knowledge in this art, but in the
31 existing industry, the molar ratio of NaF to AlF_3 is generally larger than 2.2, this is because, if

1 the molar ratio of NaF to AlF_3 further decreases, NaF and AlF_3 will lead to a 'crusting'
2 phenomenon of the cathode in the process of low-temperature electrolysis while the liquidus
3 temperature of the electrolyte is lowered, the reason for this 'crusting' phenomenon is that
4 sodium ions and aluminum ions in the electrolyte will gather at the cathode in the electrolysis
5 process to generate sodium cryolite, which is seldom molten at a low temperature due to its
6 high melting point, as a result, the surface of the cathode is covered by a layer of refractory
7 cryolite crust to affect normal electrolysis in the electrolysis process tremendously. Due to the
8 above problems in the prior art, industrial application of the electrolyte is significantly limited,
9 and it is an unsolved problem in the prior art to find a way of avoiding corrosion to electrolysis
10 devices and damage to human body and ensuring proper electric conductivity and alumina
11 solubility as well as no cathode 'crusting' phenomenon of the prepared electrolyte while the
12 liquidus temperature of the electrolyte is further lowered.

13 In addition to the high electrolysis temperature problem that needs to be solved, the carbon
14 anode in the traditional electrolytic cell for aluminum electrolysis is ceaselessly consumed by
15 oxidization in the electrolysis process, thus constant replacement for the carbon anode is
16 required; moreover, carbon dioxide, carbon monoxide and other waste gases are continuously
17 generated at the anode during aluminum electrolysis. Hence, to lessen the consumption of an
18 anode material in the aluminum electrolysis process and simultaneously reduce the emission of
19 waste gases, disclosed in the prior art is plenty of documents for research on anode material,
20 e.g. disclosed in Chinese patent document CN1443877A is an inert anode material applied to
21 aluminum, magnesium and rare earth electrolysis industries, this material is formed by binary or
22 multi-element alloy composed of chromium, nickel, ferrum, cobalt, titanium, copper, aluminum,
23 magnesium and other metals, and the preparation method thereof is a smelting or powder
24 metallurgy method. The prepared anode material is good in electric and thermal conductivity
25 and generates oxygen in the electrolysis process, wherein in Example 1, an anode is made of
26 the alloy material composed of 37wt% of cobalt, 18wt% of copper, 19wt% of nickel, 23wt% of
27 ferrum and 3wt% of silver and is used for aluminum electrolysis, the anode has a current density
28 of $1.0\text{A}/\text{cm}^2$ in the electrolysis process at 850°C and the cell voltage is maintained within a
29 range from 4.1V to 4.5V in the electrolysis process, the prepared aluminum has a purity of
30 98.35%.

31 Compared with the carbon material, the alloy anode material in the technologies
32 aforementioned has higher electric conductivity and lower corrosion amount in the electrolysis

1 process and can be processed into random shapes, however, the alloy anode composed of the
2 aforementioned components is still high in overvoltage, which results in large industrial power
3 consumption and low product quality, besides, since a large quantity of expensive metal
4 materials are used, the anode material is high in cost and cannot adapt to industrial needs.

5 In addition, a layer of oxide film is generated on the surface of the prepared alloy anode in the
6 prior art, and if this oxide film is destroyed, the anode material exposed to the surface will be
7 oxidized as a new oxide film. The oxide film on the surface of the alloy anode in the prior art has
8 low oxidization resistance and is further liable to oxidization reaction to generate products that
9 are likely to be corroded by the electrolyte, and the oxide film with low stability is liable to fall off
10 the anode electrode in the electrolysis process; after the previous oxide film is corroded or falls
11 off, the material of the alloy anode exposed to the surface will create a new oxide film by
12 reaction, such replacement between new and old oxide films results in continuous consumption
13 and poor corrosion resistance of the anode material; furthermore, the corroded or falling oxide
14 film enters into liquid aluminum in the electrolysis process of alumina to degrade the purity of
15 the final product aluminum, as a result, the manufactured aluminum product cannot meet the
16 demand of national standards and accordingly cannot be directly used as a finished product.

17 **Summary of the Invention**

18 The first technical problem to be solved by the present invention is that, the prior art is incapable
19 of avoiding corrosion to electrolysis devices and damage to human body and ensuring proper
20 electric conductivity and alumina solubility as well as no 'crusting' phenomenon in the prepared
21 electrolyte while the liquidus temperature of the electrolyte is further lowered. Thus the present
22 invention provides an electrolytic cell, containing an electrolyte for aluminum electrolysis which
23 is low in liquidus temperature, free from metal corrosion, not liable to volatilization, proper in
24 electric conductivity and alumina solubility and free from cathode 'crusting' phenomenon.

25 Simultaneously, the second technical problem to be solved by the present invention is that, an
26 alloy anode composed of metal components in the prior art is high in overvoltage, power
27 consumption in the aluminum electrolysis process is large and the metal components employed
28 are high in price, resulting in cost increment of the alloy anode; in addition, an oxide film on the
29 surface of the alloy anode in the prior art is low in oxidation resistance and liable to fall off,
30 which leads to continuous consumption of the alloy anode and poor corrosion resistance,
31 furthermore, the corroded or falling oxide film enters into liquid aluminum to degrade the purity
32 of the final product aluminum; and therefore, provided is an electrolytic cell for aluminum

1 electrolysis, which is low in overvoltage of the used inert anode material, low in price, strong in
2 oxidation resistance and stability of the oxide film formed on the surface thereof and resistant to
3 electrolyte corrosion.

4 Simultaneously, the present invention provides a process for aluminum electrolysis using the
5 above electrolytic cell.

6 To solve the aforementioned technical problems, the present invention provides an electrolytic
7 cell for aluminum electrolysis, comprising a cell body, wherein an anode and a cathode are
8 arranged inside the cell body, the cell body is further filled with an electrolyte; the anode is
9 arranged above the cell body, and at least a part of the anode is immersed in the electrolyte; the
10 cathode is arranged at the bottom of the electrolytic cell and covered by a certain amount of
11 aluminum liquid; the electrolyte is located between the anode and the cathode; the anode
12 contains the components including Fe, Cu, Ni and Sn, wherein Fe and Cu serve as primary
13 components; the electrolyte is composed of 30-38wt% of NaF, 49-60wt% of AlF_3 , 1-5wt% of LiF,
14 1-6wt% of KF and 3-6wt% of Al_2O_3 , wherein the molar ratio of NaF to AlF_3 is 1.0-1.52.

15 The bottom surface of the anode is kept parallel to the cell body, and an insulating layer is
16 arranged on the inner sidewall of the cell body and is used for isolating oxygen or the electrolyte
17 from a carbon block.

18 A cell cover is arranged at the upper end of the cell body and is provided with a vent and a
19 feeding hole; a cathode bar is arranged inside the cathode, one end of the anode penetrates
20 through the cell cover and is connectedly provided with a binding post for connection with a
21 power supply.

22 The mass ratio of Fe to Cu to Sn is (23-40): (36-60): (0.2-5).

23 The components of the anode further include Ni.

24 The anode is composed of Fe, Cu, Ni and Sn, wherein the content of Fe is 23-40wt%, the
25 content of Cu is 36-60%, the content of Ni is 14-28wt% and the content of Sn is 0.2-5wt%.

26 The components of the anode further include Al and Y.

27 The anode is composed of Fe, Cu, Ni, Sn, Al and Y, wherein the content of Fe is 23-40wt%, the
28 content of Cu is 36-60wt%, the content of Ni is 14-28wt%, the content of Al is more than zero

1 and less than or equal to 4wt%, the content of Y is more than zero and less than or equal to
2 2wt%, and the content of Sn is 0.2-5wt%.

3 The molar ratio of NaF to AlF_3 is 1.12-1.52.

4 The liquidus temperature of the electrolyte is 620-670 °C.

5 An electrolysis process using the electrolytic cell comprises the steps of:

6 (1) adding specified amounts of NaF, AlF_3 , LiF, KF and Al_2O_3 to a melting furnace for mixing and
7 melting to form a melt; or adding specified amounts of NaF, AlF_3 , LiF and KF to a melting
8 furnace for mixing and melting, and then adding Al_2O_3 to obtain a melt; and

9 (2) raising the temperature of the melt prepared in step (1) to above 720-760 °C, and then,
10 pouring the melt into the electrolytic cell and carrying out electrolysis while the temperature is
11 maintained at 720-760 °C.

12 The electrolysis temperature is 730-750 °C.

13 Al_2O_3 is quantitatively supplied in the electrolysis process.

14 The electrolysis process using the electrolytic cell comprises the steps of:

15 (1) adding specified amounts of NaF, AlF_3 , LiF, KF and Al_2O_3 to a melting furnace for mixing and
16 melting to form a melt; or adding specified amounts of NaF, AlF_3 , LiF and KF to a melting
17 furnace for mixing and melting, and then adding Al_2O_3 to obtain a melt; and

18 (2) raising the temperature of the melt prepared in step (1) to above 720-760 °C, and then,
19 pouring the melt into the electrolytic cell and carrying out electrolysis while the temperature is
20 maintained at 720-760 °C.

21 The electrolysis temperature is 730-750 °C.

22 Al_2O_3 is quantitatively supplied in the electrolysis process.

23 The electrolytic cell and the electrolysis process using the electrolytic cell in the present
24 invention have the advantages below:

1 (1) The electrolytic cell for aluminum electrolysis in the present invention comprises a cell body,
2 wherein an anode and a cathode are arranged inside the cell body, and the cell body is further
3 filled with an electrolyte; the anode is arranged above the cell body, and at least a part of the
4 anode is immersed in the electrolyte; the cathode is arranged at the bottom of the electrolytic
5 cell and covered by a certain amount of aluminum liquid; the electrolyte is located between the
6 anode and the cathode; the anode contains the components including Fe, Cu, Ni and Sn,
7 wherein Fe and Cu serve as primary components; the electrolyte is composed of 30-38wt% of
8 NaF, 49-60wt% of AlF_3 , 1-5wt% of LiF, 1-6wt% of KF and 3-6wt% of Al_2O_3 , wherein the molar
9 ratio of NaF to AlF_3 is 1.0-1.52.

10 The anode containing metal Sn and composed of the aforementioned metal components is high
11 in electric conductivity and low in overvoltage, the cell voltage in the electrolysis process of the
12 electrolytic cell is about 3.1-3.4V, power consumption in the aluminum electrolysis process is
13 small, the power consumption for per ton of aluminum is not more than 11000kw·h, so the
14 process cost is low; the anode material is alloy composed of Fe, Cu and Sn, so an oxide film
15 formed on the surface of the anode in the electrolysis process is high in oxidation resistance
16 and is hardly corroded by the electrolyte, and the formed oxide film is stable and not liable to fall
17 off, therefore, the anode is imparted with quite high oxidation resistance and strong corrosion
18 resistance so as to ensure the purity of aluminum products, that is, the purity of the produced
19 aluminum can reach 99.8%. The following problems in the prior art are avoided: the alloy anode
20 has high overvoltage, the oxide film on the alloy surface is low in oxidation resistance and liable
21 to fall off, which leads to continuous consumption of the alloy anode and poor corrosion
22 resistance, furthermore, the corroded or falling oxide film enters into liquid aluminum to degrade
23 the purity of the final product aluminum. In addition, Fe and Cu serve as primary components of
24 the alloy anode and their content proportions are quite high, and accordingly, the manufacturing
25 cost of the anode material is lowered.

26 The used electrolyte employs a pure fluoride system, substance composition in the electrolyte is
27 defined, the contents of these substances are further defined and the molar ratio of NaF to AlF_3
28 is 1.0-1.52, so that the liquidus temperature of the electrolyte is lowered to 640-670°C, as a
29 result, electrolysis can be carried out at 720-760°C according to the electrolysis process, which
30 reduces volatilization loss of fluoride salt, avoids corrosion to electrolysis devices and damage
31 to human body, improves working environment, greatly reduces energy consumption in the
32 electrolysis process and achieves the aim of energy saving and emission reduction; meanwhile,

1 in the present invention, proper amounts of LiF and KF are added and can be combined with
2 sodium ions and aluminum ions in the electrolyte to form lithium cryolite and potassium cryolite
3 with low melting points, thus the crusting phenomenon is avoided in the electrolysis process;
4 compared with the existing industry, the electrolyte for aluminum electrolysis in the present
5 invention has no CaF_2 and MgF_2 added therein, instead, KF in an appropriate proportion, which
6 has the function of increasing alumina solubility and dissolution velocity, is added to a system in
7 which the molar ratio of NaF to AlF_3 is 1.0-1.52, therefore, the shortcoming of low alumina
8 solubility in the low-molar-ratio electrolyte is improved; in general, the electric conductivity of the
9 electrolyte decreases as the temperature decreases, so typically, the electric conductivity at a
10 low electrolysis temperature hardly meets the demand in a normal electrolysis process; the
11 electrolysis temperature is lowered by lowering the liquidus temperature of the electrolyte in the
12 present invention, however, the electric conductivity of the electrolyte at a low temperature can
13 still meet the demand in the electrolysis process because LiF with a larger electric conductivity
14 is added and component proportions in the electrolyte are optimized, thus enhancing the current
15 efficiency in the electrolysis process. According to the invention, the content of LiF is defined as
16 1-5%, this is because too low content of LiF fails to improve electric conductivity and to prevent
17 crusting, and too high content of LiF results in decrease of the alumina solubility, and the above
18 two situations are effectively avoided by defining the content of LiF as 1-5% in the present
19 invention; and there is no corrosion to a metal device when the electrolyte with the above
20 proportions in the present invention is used, in this way, the service life of the electrolysis device
21 is prolonged.

22 (2) In the electrolytic cell for aluminum electrolysis in the present invention, the anode is
23 composed of Fe, Cu, Ni, Sn, Al and Y, wherein the content of Fe is 23-40wt%, the content of Cu
24 is 36-60wt%, the content of Ni is 14-28wt%, the content of Al is less than or equal to 4wt%, the
25 content of Y is less than or equal to 2wt%, and the content of Sn is 0.2-5wt%.

26 Similarly, the aforementioned inert alloy anode has the advantages of low material cost and high
27 electric conductivity, in addition, the metal Al contained in the aforementioned inert alloy anode
28 plays a role of oxidization resistance and can serve as a reducing agent for metallothermic
29 reduction reaction with metal oxides in the inert anode alloy, thus preventing the metals in the
30 inert alloy anode, i.e. primary components, from being oxidized, and causing reduction of the
31 electric conductivity of the alloy anode; meanwhile, the metal Y added can be used for

1 controlling a crystal structure for anode material formation in the preparation process of the inert
2 anode, achieving the anti-oxidization purpose.

3 (3) In the electrolytic cell for aluminum electrolysis in the present invention, specified amounts of
4 NaF, AlF_3 , LiF, KF and Al_2O_3 are mixed, the resultant mixture is heated to form a melt; or
5 specified amounts of NaF, AlF_3 , LiF and KF are mixed, the resultant mixture is heated until the
6 mixture is molten, and then Al_2O_3 is added to obtain a melt; afterwards, the melt prepared is
7 electrolyzed at 720-760°C. Electrolysis temperature is directly associated with volatilization of
8 the electrolyte, cathode crusting phenomenon, energy consumption of the process, electric
9 conductivity and alumina solubility, and the inventor of the present invention, by long search, set
10 the electrolysis temperature within a range from 720-760°C in a matching way based on the
11 components and content characteristics of the electrolyte in the present invention, thus the
12 cathode crusting phenomenon is prevented and volatilization of the electrolyte and energy
13 consumption of the electrolysis process are remarkably reduced while both the electric
14 conductivity and the alumina solubility are increased, and the economic efficiency of the process
15 is improved. Preferably, the electrolysis temperature is further set within a range from 730-
16 750°C in the present invention.

17 **Brief Description of the Drawings**

18 For more easily understanding the contents of the present invention, further description will be
19 made below to the technical solution of the present invention in conjunction with the drawing
20 and the embodiments.

21 Fig.1 is a structure diagram of the electrolytic cell for aluminum electrolysis in the present
22 invention;

23 In this drawing, reference signs are as follows: 1 refers to cell body, 2 refers to anode, 3 refers
24 to cathode, 4 refers to electrolyte, 5 refers to insulating layer, 6 refers to cell cover, 7 refers to
25 vent, 8 refers to feeding hole, 9 refers to binding post, 10 refers to cathode bar and 11 refers to
26 aluminum liquid.

27 **Detailed Description of the Embodiments**

28 The electrolytic cell for aluminum electrolysis in the present invention is as shown in Fig.1 and
29 comprises a cell body 1, wherein an anode 2 and a cathode 3 are arranged inside the cell body
30 1, the anode 2 and the cathode 3 can be arranged in random ways in accordance with the
31 actual need, in this embodiment, the anode 2 is arranged above the cell body 1, the bottom

1 surface of the anode 2 is kept parallel to the cell body 1, the cathode 3 is arranged at the bottom
2 of the electrolytic cell and covered by a certain amount of aluminum liquid 11; the cell body 1 is
3 further filled with an electrolyte 4, immersion of the anode 2 and the cathode 3 in the electrolyte
4 4 depends on the selected electrolytic cell structure, in this embodiment, at least a part of the
5 anode 2 is immersed in the electrolyte 4; the cathode 3 is arranged at the bottom of the
6 electrolytic cell and covered by a certain amount of aluminum liquid 11; the electrolyte 4 is
7 located between the anode 2 and the cathode 3 and covers the aluminum liquid 11; the anode 2
8 contains the components including Fe, Cu, Ni and Sn, wherein Fe and Cu serve as primary
9 components, and the molar ratio of Fe to Cu to Sn is (23-40): (36-60): (0.2-5); the electrolyte 4
10 is composed of 30-38wt% of NaF, 49-60wt% of AlF_3 , 1-5wt% of LiF, 1-6wt% of KF and 3-6wt%
11 of Al_2O_3 , wherein the molar ratio of NaF to AlF_3 is 1.0-1.52, preferably 1.12-1.52, and the
12 liquidus temperature of the electrolyte 4 is 620-670°C, preferably 640-670°C.

13 As a variable embodiment on this basis, in order to isolate the inner sidewall of the cell body 1
14 from the electrolyte 4 and oxygen to prevent transfer of electrons between the sidewall of the
15 cell body 1 and the electrolyte 4 and corrosion of the electrolyte 4 to the sidewall of the cell body
16 1, an insulating layer 5 is arranged on the inner sidewall of the cell body 1 and is made of any
17 commercially available insulating material that is resistant to high temperature and corrosion of
18 the electrolyte 4, e.g. corundum, aluminate spinel refractory and the like. In this embodiment, a
19 carbon block is arranged between the inner sidewall of the cell body 1 and the insulating layer 5,
20 and the carbon block and the cathode 3 are integrally formed. Undoubtedly, the carbon block
21 and the cathode 3 can also be arranged in a separated manner.

22 On this basis, in order to isolate the electrolysis environment for the electrolytic cell from outside
23 without impediment to exhaust and feeding, a cell cover 6 is arranged at the upper end of the
24 cell body 1 and is provided with a vent 7 and a feeding hole 8 thereon, the sizes and positions of
25 the vent 7 and the feeding hole can be randomly determined in accordance with the actual
26 need, and in this embodiment, the vent 7 is arranged next to the anode 2.

27 Further, in order to facilitate connection of the anode 2 and the cathode 3 with a power supply, a
28 cathode bar 10 is arranged on the cathode 3 at the bottom of the electrolytic cell and is used for
29 connection with the power supply of the cathode 3; one end of the anode 2 penetrates through
30 the cell cover 6 and is connected and provided with a binding post 9 for connection with the
31 power supply of the anode 2; and the cathode 10 and the binding post 9 can be made of any
32 material with good electric conductivity, including steel, iron and alloy materials, etc.

1 On this basis, in order to improve the combination firmness among metals Fe, Cu and Sn, the
2 components of the anode 2 further include Ni, preferably the anode 2 is composed of Fe, Cu, Ni
3 and Sn, wherein the content Fe is 23-40wt%, the content of Cu is 36-60wt%, the content of Ni is
4 14-28wt% and the content of Sn is 0.2-5wt%.

5 The anode 2 may be preferably composed of Fe, Cu, Ni, Sn, Al and Y, the added Al can prevent
6 other primary metal components of the anode 2 from oxidation and improve the oxidization
7 resistance, the component Y can be used for regulating and controlling the structure of the
8 prepared alloy crystal in order to achieve the anti-oxidization purpose, wherein the content of Fe
9 is 23-40wt%, the content of Cu is 36-60wt%, the content of Ni is 14-28wt%, the content of Al is
10 less than or equal to 4wt%, the content of Y is less than or equal to 2wt%, and the content of Sn
11 is 0.2-5wt%.

12 The electrolysis temperature is 720-760°C when the aforementioned electrolytic cell is used for
13 aluminum electrolysis, preferably 730-750°C.

14 Description is made below in conjunction with the embodiments.

15 **Embodiment 1**

16 Fe, Cu, Ni and Sn metal blocks are mixed based on 23wt% of Fe, 60wt% of Cu, 14wt% of Ni
17 and 3wt% of Sn, the mixture is molten by heating at high temperature and then subjected to
18 casting to obtain an anode 1. The anode 1 has a density of $8.3/\text{cm}^3$, a specific resistivity of
19 $68\mu\Omega\cdot\text{cm}$ and a melting point of 1360°C.

20 The components of the electrolyte in this embodiment are as follows: 32% of NaF, 57% of AlF_3 ,
21 3% of LiF, 4% of KF and 4% of Al_2O_3 , wherein the molar ratio of NaF to aluminum fluoride AlF_3
22 is 1.12. The liquidus temperature of the electrolyte in this embodiment is 640°C according to
23 measurement. The electrolyte has an electric conductivity of about $1.7\Omega^{-1}\cdot\text{cm}^{-1}$, a density of
24 about $2.03\text{g}/\text{cm}^3$ and an alumina saturation concentration of 5%.

25 The process using the electrolyte in the present invention for aluminum electrolysis is as follows:

26 (1) by means of the anode 1 and the carbon body cathode, melting the aforementioned amounts
27 of NaF, AlF_3 , LiF, KF and Al_2O_3 in a melting furnace so as to form a melt; and

28 (2) raising the temperature of the melt prepared in step (1) to above 720°C in the melting
29 furnace, then pouring the melt into the electrolytic cell, switching on the power supplies of the

1 anode and the cathode, and carrying out electrolysis for 40 hours while the temperature is
2 maintained at 720°C, wherein Al_2O_3 is quantitatively supplied in the electrolysis process.

3 There is no crust at the bottom of the cell body in the electrolysis process, the cell voltage of the
4 electrolytic cell is 3.1V, the power consumption for per ton of aluminum is 10040kw•h in the
5 electrolysis process, and the prepared aluminum has a purity of 99.85%.

6 **Embodiment 2**

7 Fe, Cu, Ni and Sn metal blocks are mixed based on 40wt% of Fe, 36wt% of Cu, 19wt% of Ni
8 and 5wt% of Sn, the mixture is molten by heating at high temperature and then subjected to
9 casting to obtain an anode 2. The anode has a density of $8.1/\text{cm}^3$, a specific resistivity of
10 $76.8\mu\Omega\cdot\text{cm}$ and a melting point of 1386°C.

11 The components of the electrolyte in this embodiment are as follows: 38% of NaF, 50% of AlF_3 ,
12 2% of LiF, 5% of KF and 5% of Al_2O_3 , wherein the molar ratio of NaF to aluminum fluoride AlF_3
13 is 1.52.

14 The performances of the electrolyte in this embodiment are measured and the measurement
15 result is that the liquidus temperature of the electrolyte in this embodiment is 670°C. The
16 electrolyte has an electric conductivity of about $1.8\Omega^{-1}\cdot\text{cm}^{-1}$, a density of about $2.05\text{g}/\text{cm}^3$ and an
17 alumina saturation concentration of 6%.

18 The process using the electrolyte in the present invention for aluminum electrolysis is as follows:

19 (1) by means of the anode 2 and the carbon body cathode, melting the aforementioned amounts
20 of NaF, AlF_3 , LiF and KF in a melting furnace, and then adding the aforementioned amount of
21 Al_2O_3 to obtain a melt by melting; and

22 (2) raising the temperature of the melt prepared in step (1) to above 760°C in the melting
23 furnace, then pouring the melt into the electrolytic cell, switching on the power supplies of the
24 anode and the cathode, and carrying out electrolysis for 40 hours while the temperature is
25 maintained at 760°C.

26 There is no crust at the bottom of the cell body in the electrolysis process, the cell voltage of the
27 electrolytic cell is 3.39V, the power consumption for per ton of aluminum is 10979kw•h in the
28 electrolysis process, and the prepared aluminum has a purity of 99.82%.

1 **Embodiment 3**

2 Fe, Cu, Ni and Sn metal blocks are mixed based on 25wt% of Fe, 46.8wt% of Cu, 28wt% of Ni
3 and 0.2wt% of Sn, the mixture is molten by heating at high temperature and then subjected to
4 casting to obtain an anode 3. The anode has a density of $8.2/\text{cm}^3$, a specific resistivity of
5 $72\mu\Omega\cdot\text{cm}$ and a melting point of 1350°C .

6 The components of the electrolyte in this embodiment are as follows: 32% of NaF, 57% of AlF_3 ,
7 3% of LiF, 4% of KF and 4% of Al_2O_3 , wherein the molar ratio of NaF to aluminum fluoride AlF_3
8 is 1.12.

9 The performances of the electrolyte in this embodiment are measured and the measurement
10 result is that the liquidus temperature of the electrolyte in this embodiment is 640°C . The
11 electrolyte has an electric conductivity of about $1.6\Omega^{-1}\cdot\text{cm}^{-1}$, a density of about $2.03\text{g}/\text{cm}^3$ and an
12 alumina saturation concentration of 5%.

13 The process using the electrolyte in the present invention for aluminum electrolysis is as follows:

14 (1) by means of the anode 3 and the carbon body cathode, melting the aforementioned amounts
15 of NaF, AlF_3 , LiF, KF and Al_2O_3 in a melting furnace so as to form a melt; and

16 (2) raising the temperature of the melt prepared in step (1) to above 730°C in the melting
17 furnace, then pouring the melt into the electrolytic cell, switching on the power supplies of the
18 anode and the cathode, and carrying out electrolysis for 40 hours while the temperature is
19 maintained at 730°C , wherein Al_2O_3 is quantitatively supplied in the electrolysis process.

20 There is no crust at the bottom of the cell body in the electrolysis process, the cell voltage of the
21 electrolytic cell is 3.15V, the power consumption for per ton of aluminum is $10202\text{kw}\cdot\text{h}$ in the
22 electrolysis process, and the prepared aluminum has a purity of 99.85%.

23 **Embodiment 4**

24 Fe, Cu, Ni and Sn metal blocks are mixed based on 24.2wt% of Fe, 60wt% of Cu, 14wt% of Ni
25 and 0.2wt% of Sn, the mixture is molten by heating at high temperature, 1.8wt% of Al metal
26 block is then added for continuous melting and mixing, and finally, 0.8wt% of Y metal block is
27 added for melting and mixing and an anode 4 is obtained by casting of the mixture. The anode
28 has a density of $8.3/\text{cm}^3$, a specific resistivity of $68\mu\Omega\cdot\text{cm}$ and a melting point of 1360°C .

1 The components of the electrolyte in this embodiment are as follows: 32% of NaF, 57% of AlF_3 ,
2 3% of LiF, 4% of KF and 4% of Al_2O_3 , wherein the molar ratio of NaF to aluminum fluoride AlF_3
3 is 1.12.

4 The performances of the electrolyte in this embodiment are measured and the measurement
5 result is that the liquidus temperature of the electrolyte in this embodiment is 640°C . The
6 electrolyte has an electric conductivity of about $1.8\Omega^{-1}\cdot\text{cm}^{-1}$, a density of about $2.04\text{g}/\text{cm}^3$ and an
7 alumina saturation concentration of 6%.

8 The process using the electrolyte in the present invention for aluminum electrolysis is as follows:

9 (1) by means of the anode 4 and the carbon body cathode, melting the aforementioned amounts
10 of NaF, AlF_3 , LiF, KF and Al_2O_3 in a melting furnace so as to form a melt; and

11 (2) raising the temperature of the melt prepared in step (1) to above 750°C in the melting
12 furnace, then pouring the melt into the electrolytic cell, switching on the power supplies of the
13 anode and the cathode, and carrying out electrolysis for 40 hours while the temperature is
14 maintained at 750°C , wherein Al_2O_3 is quantitatively supplied in the electrolysis process.

15 There is no crust at the bottom of the cell body in the electrolysis process, the cell voltage of the
16 electrolytic cell is 3.12V, the power consumption for per ton of aluminum is 10105kw·h in the
17 electrolysis process, and the prepared aluminum has a purity of 99.8%.

18 **Embodiment 5**

19 Fe, Cu, Ni and Sn metal blocks are mixed based on 40wt% of Fe, 36wt% of Cu, 14.9wt% of Ni
20 and 5wt% of Sn, the mixture is molten by heating at high temperature, 0.1wt% of Al metal block
21 is then added for continuous melting and mixing, and finally, 0.1wt% of Y metal block is added
22 for melting and mixing and an anode 5 is obtained by casting of the mixture. The anode has a
23 density of $8.1/\text{cm}^3$, a specific resistivity of $76.8\mu\Omega\cdot\text{cm}$ and a melting point of 1386°C .

24 The components of the electrolyte in this embodiment are as follows: 30% of NaF, 60% of AlF_3 ,
25 1% of LiF, 6% of KF and 3% of Al_2O_3 , wherein the molar ratio of NaF to aluminum fluoride AlF_3
26 is 1.0.

27 The performances of the electrolyte in this embodiment are measured and the measurement
28 result is that the liquidus temperature of the electrolyte in this embodiment is 620°C . The

1 electrolyte has an electric conductivity of about $1.6\Omega^{-1}\cdot\text{cm}^{-1}$, a density of about $2.03\text{g}/\text{cm}^3$ and an
2 alumina saturation concentration of 5%.

3 The process using the electrolyte in the present invention for aluminum electrolysis is as follows:

4 (1) by means of the anode 5 and the carbon body cathode, melting the aforementioned amounts
5 of NaF, AlF_3 , LiF, KF and Al_2O_3 in a melting furnace so as to form a melt; and

6 (2) raising the temperature of the melt prepared in step (1) to above 720°C in the melting
7 furnace, then pouring the melt into the electrolytic cell, switching on the power supplies of the
8 anode and the cathode, and carrying out electrolysis for 40 hours while the temperature is
9 maintained at 720°C , wherein Al_2O_3 is quantitatively supplied in the electrolysis process.

10 There is no crust at the bottom of the cell body in the electrolysis process, the cell voltage of the
11 electrolytic cell is 3.27V, the power consumption for per ton of aluminum is 10591kw·h in the
12 electrolysis process, and the prepared aluminum has a purity of 99.81%.

13 **Embodiment 6**

14 Fe, Cu, Ni and Sn metal blocks are mixed based on 25wt% of Fe, 38wt% of Cu, 28wt% of Ni
15 and 4wt% of Sn, the mixture is molten by heating at high temperature, 4wt% of Al metal block is
16 then added for continuous melting and mixing, and finally, 1wt% of Y metal block is added for
17 melting and mixing and an anode 6 is obtained by casting of the mixture. The anode has a
18 density of $8.2/\text{cm}^3$, a specific resistivity of $70\mu\Omega\cdot\text{cm}$ and a melting point of 1365°C .

19 The components of the electrolyte in this embodiment are as follows: 38% of NaF, 54% of AlF_3 ,
20 4% of LiF, 1% of KF and 3% of Al_2O_3 , wherein the molar ratio of NaF to aluminum fluoride AlF_3
21 is 1.4.

22 The performances of the electrolyte in this embodiment are measured and the measurement
23 result is that: the liquidus temperature of the electrolyte in this embodiment is 670°C . The
24 electrolyte has an electric conductivity of about $1.8\Omega^{-1}\cdot\text{cm}^{-1}$, a density of about $2.05\text{g}/\text{cm}^3$ and an
25 alumina saturation concentration of 6%.

26 The process using the electrolyte in the present invention for aluminum electrolysis is as follows:

27 (1) by means of the anode 6 and the carbon body cathode, melting the aforementioned amounts
28 of NaF, AlF_3 , LiF, KF and Al_2O_3 in a melting furnace so as to form a melt; and

1 (2) raising the temperature of the melt prepared in step (1) to above 760°C in the melting
2 furnace, then pouring the melt into the electrolytic cell, switching on the power supplies of the
3 anode and the cathode, and carrying out electrolysis for 40 hours while the temperature is
4 maintained at 760°C, wherein Al_2O_3 is quantitatively supplied in the electrolysis process.

5 There is no crust at the bottom of the cell body in the electrolysis process, the cell voltage of the
6 electrolytic cell is 3.35V, the power consumption for per ton of aluminum is 10850kw•h in the
7 electrolysis process, and the prepared aluminum has a purity of 99.83%.

8 **Embodiment 7**

9 Fe, Cu, Ni and Sn metal blocks are mixed based on 40wt% of Fe, 36.5wt% of Cu, 18wt% of Ni
10 and 3wt% of Sn, the mixture is molten by heating at high temperature, 1.5wt% of Al metal block
11 is then added for continuous melting and mixing, and finally, 1wt% of Y metal block is added for
12 melting and mixing and an anode 7 is obtained by casting of the mixture. The anode has a
13 density of $8.1/\text{cm}^3$, a specific resistivity of $76.8\mu\Omega\cdot\text{cm}$ and a melting point of 1386°C.

14 The components of the electrolyte in this embodiment are as follows: 34% of NaF, 49% of AlF_3 ,
15 5% of LiF, 6% of KF and 6% of Al_2O_3 , wherein the molar ratio of NaF to aluminum fluoride AlF_3
16 is 1.39.

17 The performances of the electrolyte in this embodiment are measured and the measurement
18 result is that the liquidus temperature of the electrolyte in this embodiment is 660°C. The
19 electrolyte has an electric conductivity of about $1.8\Omega^{-1}\cdot\text{cm}^{-1}$, a density of about $2.05\text{g}/\text{cm}^3$ and an
20 alumina saturation concentration of 6%.

21 The process using the electrolyte in the present invention for aluminum electrolysis is as follows:

22 (1) by means of the anode 7 and the carbon body cathode, melting the aforementioned amounts
23 of NaF, AlF_3 , LiF, KF and Al_2O_3 in a melting furnace so as to form a melt; and

24 (2) raising the temperature of the melt prepared in step (1) to above 760°C in the melting
25 furnace, then pouring the melt into the electrolytic cell, switching on the power supplies of the
26 anode and the cathode, and carrying out electrolysis for 40 hours while the temperature is
27 maintained at 760°C, wherein Al_2O_3 is quantitatively supplied in the electrolysis process.

- 1 There is no crust at the bottom of the cell body in the electrolysis process, the cell voltage of the
2 electrolytic cell is 3.38V, the power consumption for per ton of aluminum is 10947kw•h in the
3 electrolysis process, and the prepared aluminum has a purity of 99.8%.
- 4 The electrolytic cell in the aforementioned embodiments is any of the electrolytic cells in the
5 present invention.
- 6 Detailed description has been made to the specific contents of the present invention in the
7 aforementioned embodiments, and it should be understood by those skilled in this art that
8 modifications and detail variations in any form based upon the present invention pertain to the
9 contents that the present invention seeks to protect.
- 10

Claims

1. An electrolytic cell for aluminum electrolysis, comprising:
a cell body (1), an anode (2) and a cathode (3) being arranged inside the cell body (1), the cell body (1) being further filled with an electrolyte (4);
the anode (2) being arranged above the cell body (1), and at least a part of the anode (2) being immersed in the electrolyte (4);
the cathode (3) being arranged at the bottom of the electrolytic cell and covered by a certain amount of aluminum liquid (11);
the electrolyte (4) being located between the anode (2) and the cathode (3);
characterized in that
the anode (2) contains the components including Fe, Cu, Ni and Sn, wherein Fe and Cu serve as primary components; and
the electrolyte (4) is composed of 30-38wt% of NaF, 49-60wt% of AlF_3 , 1-5wt% of LiF, 1-6wt% of KF and 3-6wt% of Al_2O_3 , wherein the molar ratio of NaF to AlF_3 is 1.0-1.52.
2. The electrolytic cell according to claim 1, characterized in that the bottom surface of the anode (2) is kept parallel to the cell body (1), and an insulating layer (5) is arranged on the inner sidewall of the cell body (1) and is used for isolating oxygen or the electrolyte (4) from a carbon block.
3. The electrolytic cell according to claim 1 or 2, characterized in that a cell cover (6) is arranged at the upper end of the cell body (1) and is provided with a vent (7) and a feeding hole (8); a cathode bar (10) is arranged inside the cathode (3), one end of the anode (2) penetrates through the cell cover (6) and is connected and provided with a binding post (9) for connection with a power supply.
4. The electrolytic cell according to any of claims 1-3, characterized in that the mass ratio of Fe to Cu to Sn is (23-40): (36-60): (0.2-5).
5. The electrolytic cell according to any of claims 1-4, characterized in that the components of the anode (2) further include Ni.

6. The electrolytic cell according to claim 5, characterized in that the anode (2) is composed of Fe, Cu, Ni and Sn, wherein the content of Fe is 23-40wt%, the content of Cu is 36-60wt%, the content of Ni is 14-28wt% and the content of Sn is 0.2-5wt%.
7. The electrolytic cell according to any of claims 1-6, characterized in that the components of the anode (2) further include Al and Y.
8. The electrolytic cell according to claim 7, characterized in that the anode (2) is composed of Fe, Cu, Ni, Sn, Al and Y, wherein the content of Fe is 23-40wt%, the content of Cu is 36-60wt%, the content of Ni is 14-28wt%, the content of Al is more than zero and less than or equal to 4wt%, the content of Y is more than zero and less than or equal to 2wt%, and the content of Sn is 0.2-5wt%.
9. The electrolytic cell according to any of claims 1-8, characterized in that the molar ratio of NaF to AlF_3 is 1.12-1.52.
10. The electrolytic cell according to any of claims 1-9, characterized in that the liquidus temperature of the electrolyte (4) is 620-670°C.
11. An electrolysis process using the electrolytic cell according to any of claims 1-10, comprising the steps of:
 - (1) adding specified amounts of NaF, AlF_3 , LiF, KF and Al_2O_3 to a melting furnace for mixing and melting to form a melt; or adding specified amounts of NaF, AlF_3 , LiF and KF to a melting furnace for mixing and melting, and then adding Al_2O_3 to obtain a melt; and
 - (2) raising the temperature of the melt prepared in step (1) to above 720-760°C, and then, pouring the melt into the electrolytic cell and carrying out electrolysis while the temperature is maintained at 720-760°C.
12. The electrolysis process according to claim 11, characterized in that the electrolysis temperature is 730-750°C.
13. The electrolysis process according to claim 11 or 12, characterized in that Al_2O_3 is quantitatively supplied in the electrolysis process.

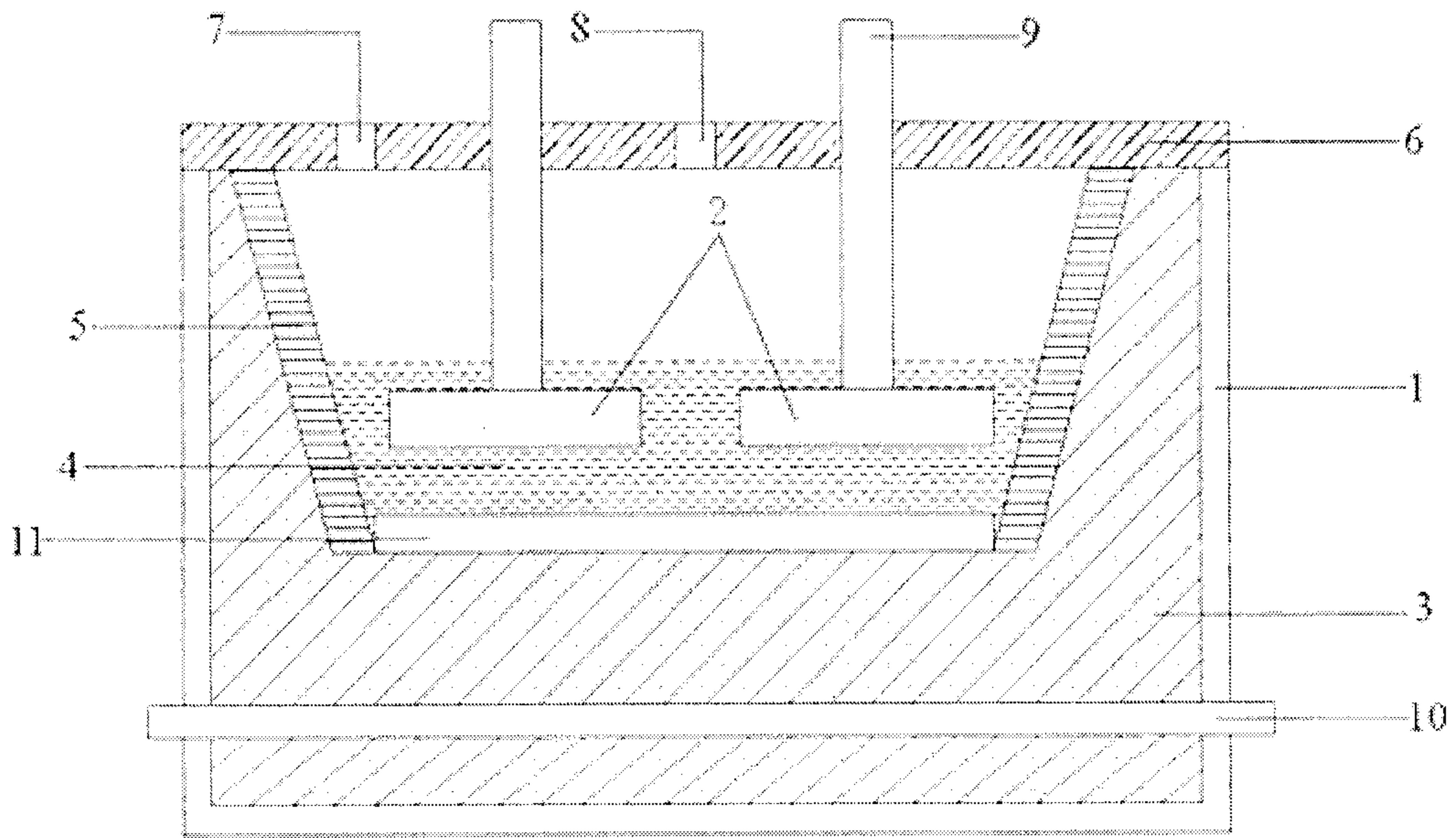

Figure 1

