

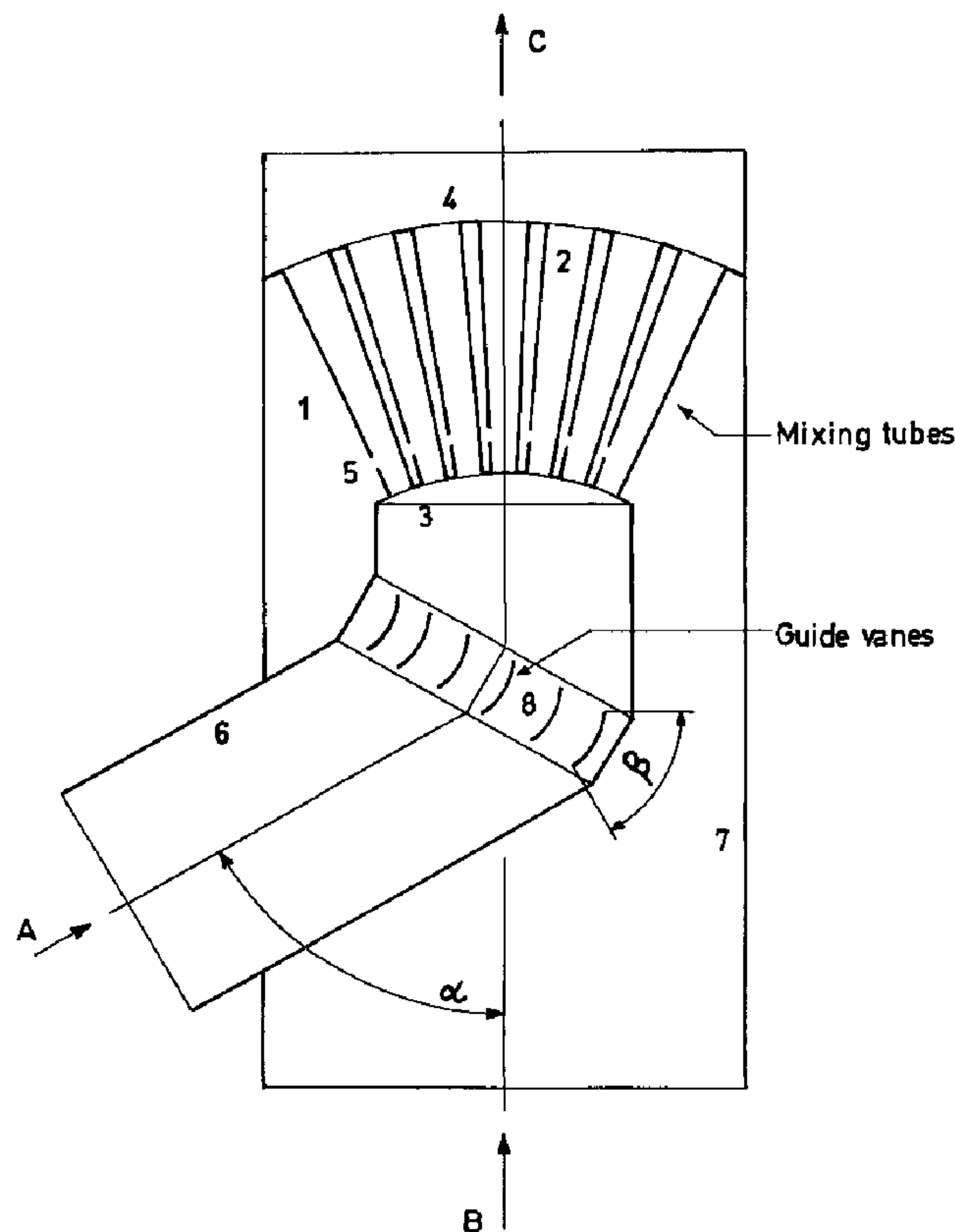

(86) **Date de dépôt PCT/PCT Filing Date:** 2008/03/19
 (87) **Date publication PCT/PCT Publication Date:** 2008/10/09
 (45) **Date de délivrance/Issue Date:** 2015/02/24
 (85) **Entrée phase nationale/National Entry:** 2009/09/22
 (86) **N° demande PCT/PCT Application No.:** EP 2008/002424
 (87) **N° publication PCT/PCT Publication No.:** 2008/119499
 (30) **Priorité/Priority:** 2007/03/29 (IT MI2007A000627)

(51) **Cl.Int./Int.Cl. B01F 5/04** (2006.01),
B01J 8/02 (2006.01), **F15D 1/04** (2006.01)
 (72) **Inventeurs/Inventors:**
 ASSANDRI, FABIO, IT;
 REGATTIERI, GIOVANNI, IT;
 BOTTONI, PAOLO, IT
 (73) **Propriétaire/Owner:**
 POLIMERI EUROPA S.P.A., IT
 (74) **Agent:** ROBIC

(54) **Titre : DISPOSITIF DE MELANGE A FAIBLE CHUTE DE PRESSION ET SON UTILISATION DANS LE MELANGE DE DEUX GAZ/VAPEURS**
 (54) **Title: LOW-PRESSURE-DROP MIXING DEVICE AND USE THEREOF IN THE MIXING OF TWO GASES/VAPOURS**



(57) **Abrégé/Abstract:**

Mixing device for two gases/vapours (hereinafter gases) comprising: a) a plurality of tubes arranged in a bundle (1), each provided, in its initial portion, with a plurality of side holes (5); b) a first feeding system of one of the two gases, comprising a first tubular body

(57) **Abrégé(suite)/Abstract(continued):**

(6) situated on the inlet side of the tubes, and c) a second feeding system of the other gas comprising a second tubular body (7) that envelopes in a gas-proof way the tube bundle (1) and at least a portion of the first tubular body (6); characterized in that: d) the first feeding system of one of the gases comprises a plurality of fins (8), inside the first tubular body (6), which allow a uniform distribution of the feeding gas to the single tubes.

(12) INTERNATIONAL APPLICATION PUBLISHED UNDER THE PATENT COOPERATION TREATY (PCT)

(19) World Intellectual Property Organization
International Bureau(43) International Publication Date
9 October 2008 (09.10.2008)

PCT

(10) International Publication Number
WO 2008/119499 A1

(51) International Patent Classification:

B01F 5/04 (2006.01) **F15D 1/04** (2006.01)
B01J 8/02 (2006.01)

(21) International Application Number:

PCT/EP2008/002424

(22) International Filing Date: 19 March 2008 (19.03.2008)

(25) Filing Language: English

(26) Publication Language: English

(30) Priority Data:

MI2007A000627 29 March 2007 (29.03.2007) IT

(71) Applicant (for all designated States except US):
POLIMERI EUROPA S.p.A. [IT/IT]; Piazza Boldrini 1,
I-20097 SAN DONATO MILANESE (IT).

(72) Inventors; and

(75) Inventors/Applicants (for US only): **ASSANDRI, Fabio**
[IT/IT]; Via Gombrich 5, I-46100 MANTOVA (IT).
REGATTIERI, Giovanni [IT/IT]; Via Tezzone, I-46040RODIGO (IT). **BOTTONI, Paolo** [IT/IT]; Via Scarsellini
5, I-46100 MANTOVA (IT).(74) Agents: **DE GREGORI, Antonella** et al.; **BARZANO'**
& **ZANARDO MILANO S.p.A.**, Via Borgonuovo 10,
I-20121 MILAN (IT).(81) Designated States (unless otherwise indicated, for every
kind of national protection available): AE, AG, AL, AM,
AO, AT, AU, AZ, BA, BB, BG, BH, BR, BW, BY, BZ, CA,
CH, CN, CO, CR, CU, CZ, DE, DK, DM, DO, DZ, EC, EE,
EG, ES, FI, GB, GD, GE, GH, GM, GT, HN, HR, HU, ID,
IL, IN, IS, JP, KE, KG, KM, KN, KP, KR, KZ, LA, LC,
LK, LR, LS, LT, LU, LY, MA, MD, ME, MG, MK, MN,
MW, MX, MY, MZ, NA, NG, NI, NO, NZ, OM, PG, PH,
PL, PT, RO, RS, RU, SC, SD, SE, SG, SK, SL, SM, SV,
SY, TJ, TM, TN, TR, TT, TZ, UA, UG, US, UZ, VC, VN,
ZA, ZM, ZW.(84) Designated States (unless otherwise indicated, for every
kind of regional protection available): ARIPO (BW, GH,
GM, KE, LS, MW, MZ, NA, SD, SL, SZ, TZ, UG, ZM,
ZW), Eurasian (AM, AZ, BY, KG, KZ, MD, RU, TJ, TM),
European (AT, BE, BG, CH, CY, CZ, DE, DK, EE, ES, FI,

[Continued on next page]

(54) Title: LOW-PRESSURE-DROP MIXING DEVICE AND USE THEREOF IN THE MIXING OF TWO GASES/VAPOURS

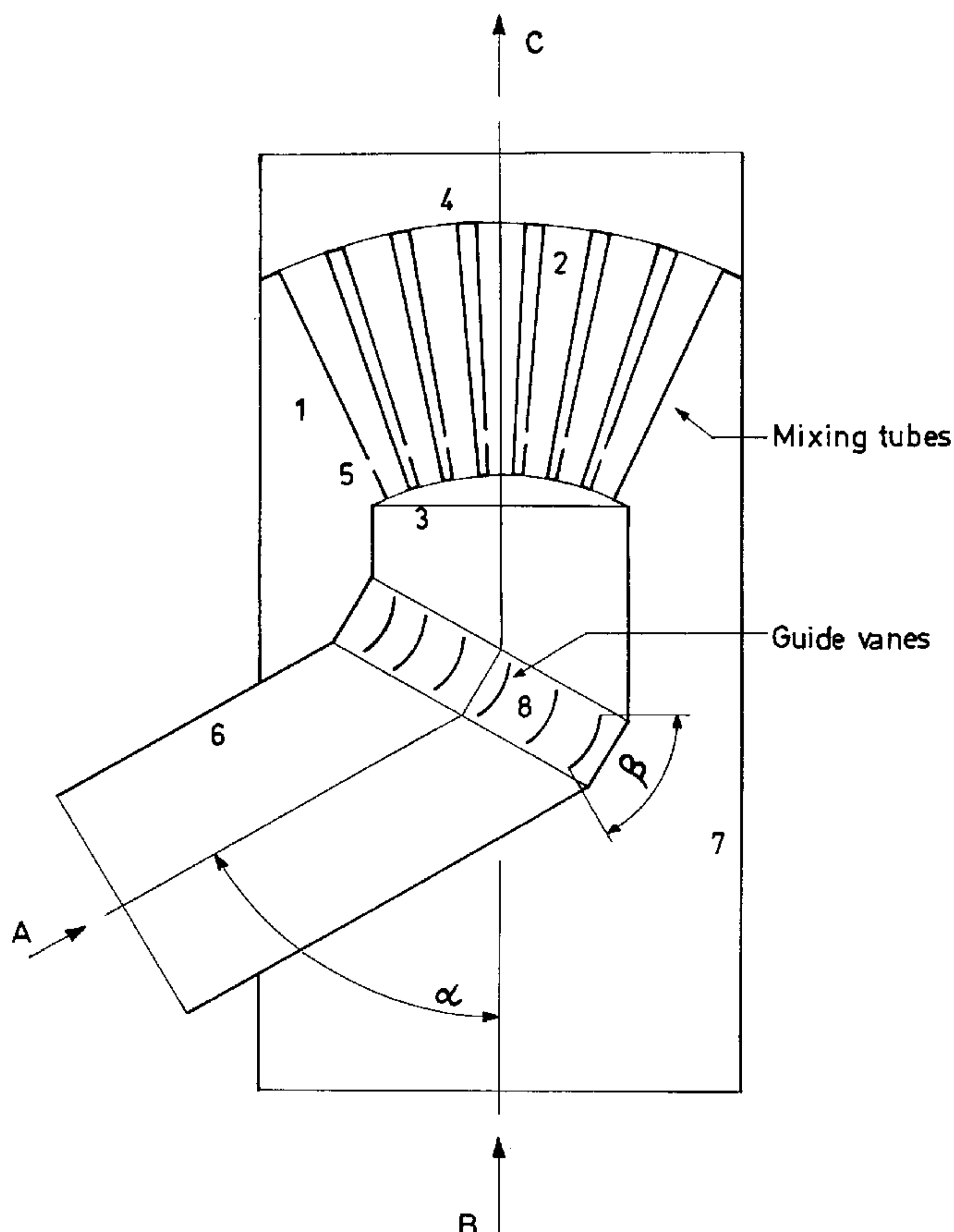
(57) Abstract: Mixing device for two
gases/vapours (hereinafter gases) comprising: a)
a plurality of tubes arranged in a bundle (1), each
provided, in its initial portion, with a plurality
of side holes (5); b) a first feeding system of one
of the two gases, comprising a first tubular body
(6) situated on the inlet side of the tubes, and c)
a second feeding system of the other gas comprising
a second tubular body (7) that envelopes in a
gas-proof way the tube bundle (1) and at least
a portion of the first tubular body (6); character-
ized in that: d) the first feeding system of one of
the gases comprises a plurality of fins (8), inside
the first tubular body (6), which allow a uniform
distribution of the feeding gas to the single tubes.

WO 2008/119499 A1

WO 2008/119499 A1



FR, GB, GR, HR, HU, IE, IS, IT, LT, LU, LV, MC, MT, NL,
NO, PL, PT, RO, SE, SI, SK, TR), OAPI (BF, BJ, CF, CG,
CI, CM, GA, GN, GQ, GW, ML, MR, NE, SN, TD, TG).

Published:
— *with international search report*

5

LOW-PRESSURE-DROP MIXING DEVICE AND USE THEREOF IN THE
MIXING OF TWO GASES/VAPOURS

The present invention relates to a low pressure drop
10 mixing device and the use thereof in the mixing of two
gases/vapours.

More specifically, the present invention relates to
a low-pressure-drop mixing device and the use thereof in
the mixing of ethylbenzene and steam at a high tempera-
15 ture in styrene production units.

As is known, styrene monomer is mainly produced by
the dehydrogenation of ethylbenzene at a high temperature
on a fixed bed of a solid catalyst based on iron oxides
mainly. Before entering the catalytic bed, the ethylben-
20 zene is mixed with steam at high temperature, in order
to improve the yield and reaction selectivity. The steam
has the purpose of moving the reaction equilibrium to-
wards styrene, heating the reagent mass and keeping the
catalyst clean from carbonaceous precipitates, by forming
25 water gas with the latter.

For these reasons, it is of fundamental importance that mixing between the two gases (ethylbenzene and steam) is as complete as possible. A bad mixing, which causes an inhomogeneous concentration and temperature in the gaseous stream at the inlet of the reactor, reduces the yield and process selectivity due to the formation of undesired products and also accelerates the aging rate of the catalyst.

Furthermore, in order to reduce the energy consumption and investment costs of the upstream equipment, it is required that the mixing between ethylbenzene and steam takes place with a pressure drop which is as low as possible.

Mixers for styrene monomer plants are normally structured as follows. One of the two gases (A) is used as main stream and passed into a chamber from whose walls the second gas (B) is injected. The turbulence (often increased by means of suitable promoters) and the elongated form of the chamber allow the two gases to mix. At the end of the chamber there is a static mixer to further enhance the homogeneity. It can be said that this mixing method substantially exploits the turbulent diffusion on the scale of the total diameter of the equipment.

Some mixing devices are known in literature - see, for example, international patent application WO 01/97960

or European patents EP 303,438 and EP 1,180,393 - comprising perforated tube bundles, used for mixing fluids, to be subsequently sent to a reaction area, for example a catalytic bed. The types of mixers proposed, however, under low-pressure-drop conditions inside the single tube, do not assure uniform distribution of the flow between the various tubes of the bundle and therefore do not allow a high mixing degree to be obtained, with low energy consumption.

The Applicant has now found a new type of mixer for gases, which represents an alternative to the industrial models used in styrene plants or those of the known art, which allows a good mixing to be obtained, by means of a more compact and economic solution, with very low pressure-drops, without the necessity of availing of a static mixer downstream. Therefore this new mixer is also easily adaptable to the debottlenecking of existing plants, where it is desirable to improve the mixing but there is no large space available.

An object of the present invention therefore relates to a mixing device for two gases comprising:

- a. a plurality of tubes arranged in a bundle, each provided, in its initial portion, with a plurality of side holes;
- b. a first feeding system of one of the two gases, comprising a first tubular body situated on the inlet side of the tubes; and
- c. a second feeding system of the other gas comprising a second tubular body that envelopes in a gas-proof way the tube bundle and at least a portion of the first tubular body;

characterized in that:

- d. the first feeding system of one of the gases comprises a plurality of fins, inside the first tubular body, which allow a uniform distribution of the feeding gas to the single tubes;

and further characterised in that the tubes of the tube bundle are conical, diverging from the inlet towards the outlet.

According to the mixing device, object of the present invention, the tubes of the bundle are made of steel or another metal alloy, for example nickel alloy. They are cylindrically shaped, or preferably conical, diverging from the inlet towards the outlet, their length ranges from 0.5 to 3 meters and the average inner diame-

ter ranges from 5 to 25 cm. The tubes of the bundle are arranged parallel to each other or, preferably, diverging towards the outlet of the bundle.

The initial part of each tube, for example from 10 to 50 % of its total length, contains a plurality of holes, each ranging from 5 to 50 cm², preferably from 10 to 30 cm². The axis of the holes can be perpendicular to the relative tube axis or can form an angle with the latter,

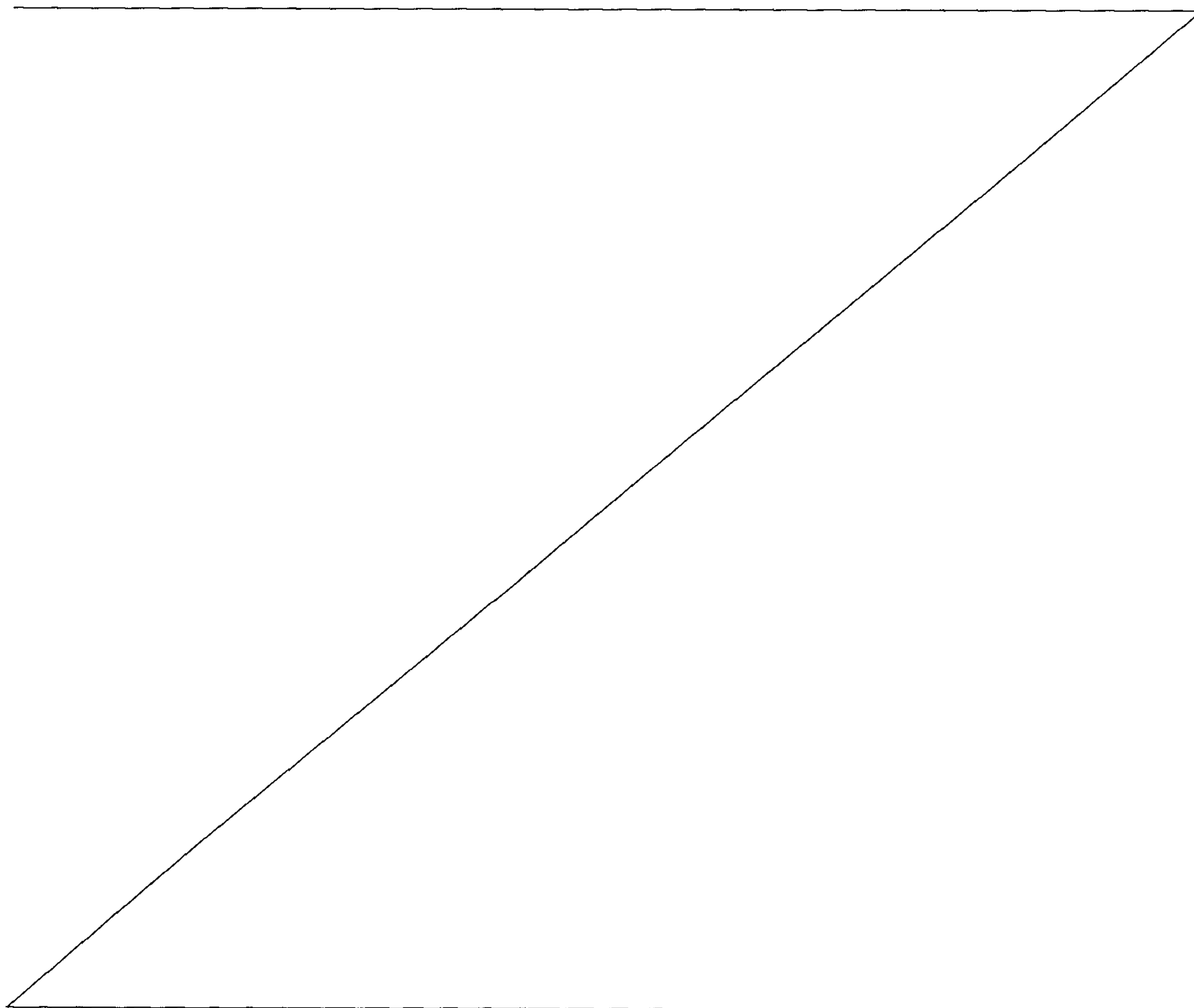

preferably ranging from 30 to 60°.

The tube bundle is generally contained between two perforated inlet and outlet tubesheets, preferably made of the same material as the tube bundle. These tubesheets
5 can have a flat circular shape or be in the form of a spherical cap, and each of the holes is suitable for containing each of the tubes of the bundle.

The first feeding system comprises a first tubular body or element inside which one of the two gases to be
10 mixed is fed, which is coupled and seal-fixed to the tubesheet at the inlet of the tube bundle.

The second feeding system comprises a second tubular body or element, inside which the other of the two gases to be mixed is fed, which envelopes in a gas proof way
15 the tube bundle, on the outlet tubesheet.

The two tubular bodies can be coaxial. In this case, the second tubular body fully englobes both the tube bundle and the first tubular body.

Alternatively, the axis of the first tubular element
20 can form an angle α with the axis of the second tubular element, ranging from 0 to 90°, or from -90 to 0°, depending on whether the projection on the horizontal plane of the first tubular element is to the left or to the right of the projection of the second tubular element. In
25 this case, the second tubular body completely englobes

the tube bundle and only partially the first tubular body.

The first feeding system of one of the two gases guarantees a uniform flow of this gas between all the bundle tubes, maintaining low pressure drops. This result is obtained thanks to the presence of a plurality of fins, suitably shaped, arranged on a transversal section, inside the first tubular body.

The number of fins ranges from 4 to 15.

In particular, said fins consist of thin plates, arc-shaped, with the centre angle β ranging from 0 to $\alpha+10^\circ$, when α ranges from 0 to 90° , or the symmetrical correspondent, when α is between -90 and 0° . In this case, the transversal section of the arrangement of the fins is that which substantially passes through the point where the two axes of the two tubular bodies meet.

When α is zero (the two tubular bodies are coaxial) β is also equal to zero.

The second tubular body forms a closed casing which envelopes in a gas proof way the tube bundle and the two tubesheets and, at least partially, the first tubular body. One of the two gases to be mixed with the other is charged inside the closed casing through a feeding section. The pressure inside the casing is maintained higher than that present in the tubes so that the gas of the

casing flows inside the tubes through the side holes.

Thanks to this subdivision and recombination mechanism, a sort of pre-mixing of the two gaseous streams is created on a large scale, and this allows the mixing of the two gases to be completed in chambers having reduced dimensions. These reduced mixing chambers are the portion of the tubes downstream of the perforated portions, where, thanks to the turbulent diffusivity on the reduced scale of the tube diameter, the close mixing of the two gases is obtained and, thanks to the reduced length, to the possible conical shape and to the orientation of the holes, the pressure drops are very low.

A process for the mixing of two gases represents a further object of the present invention, comprising:

- i. arranging a bundle of tubes having a conical section diverging from the inlet towards the outlet, equipped with a plurality of side holes in their initial part, in a sealed casing with a feeding section of one of the two gases;
- ii. feeding in continuous, inside each tube, the second of the two gases through a feeding system including a tubular body and, in its interior, a plurality of directional fins which allow the uniform

- distribution of the stream of said second gas inside the single tubes;
- iii. feeding in continuous said first gas inside the closed casing through the feeding section; and
 - iv. maintaining, inside the closed casing, a pressure of the gas which is such as to allow said first gas to flow inside said tubes, through the side holes.

According to the process, object of the present invention, in the case of the production of styrene, one of the gases consists of steam at a temperature ranging from 550 to 900°C, preferably from 650 to 850°C, and the other gas is ethylbenzene, preheated to 400-600°C, preferably between 450 and 550°C.

At the outlet of the mixing chambers, the two gases perfectly mixed, are discharged directly into the dehydrogenation reactor which operates under conventional operating conditions.

The present invention is now illustrated, for exemplifying and non-limiting purposes, through the following embodiment which refers to the enclosed figure.

In the figure, (1) represents the tube bundle consisting of a plurality of diverging tubes (2) kept assembled by means of the two inlet (3) and outlet (4)

tubesheets. Each tube has, in its initial portion, a plurality of holes (5).

The first tubular body (6) is connected to the

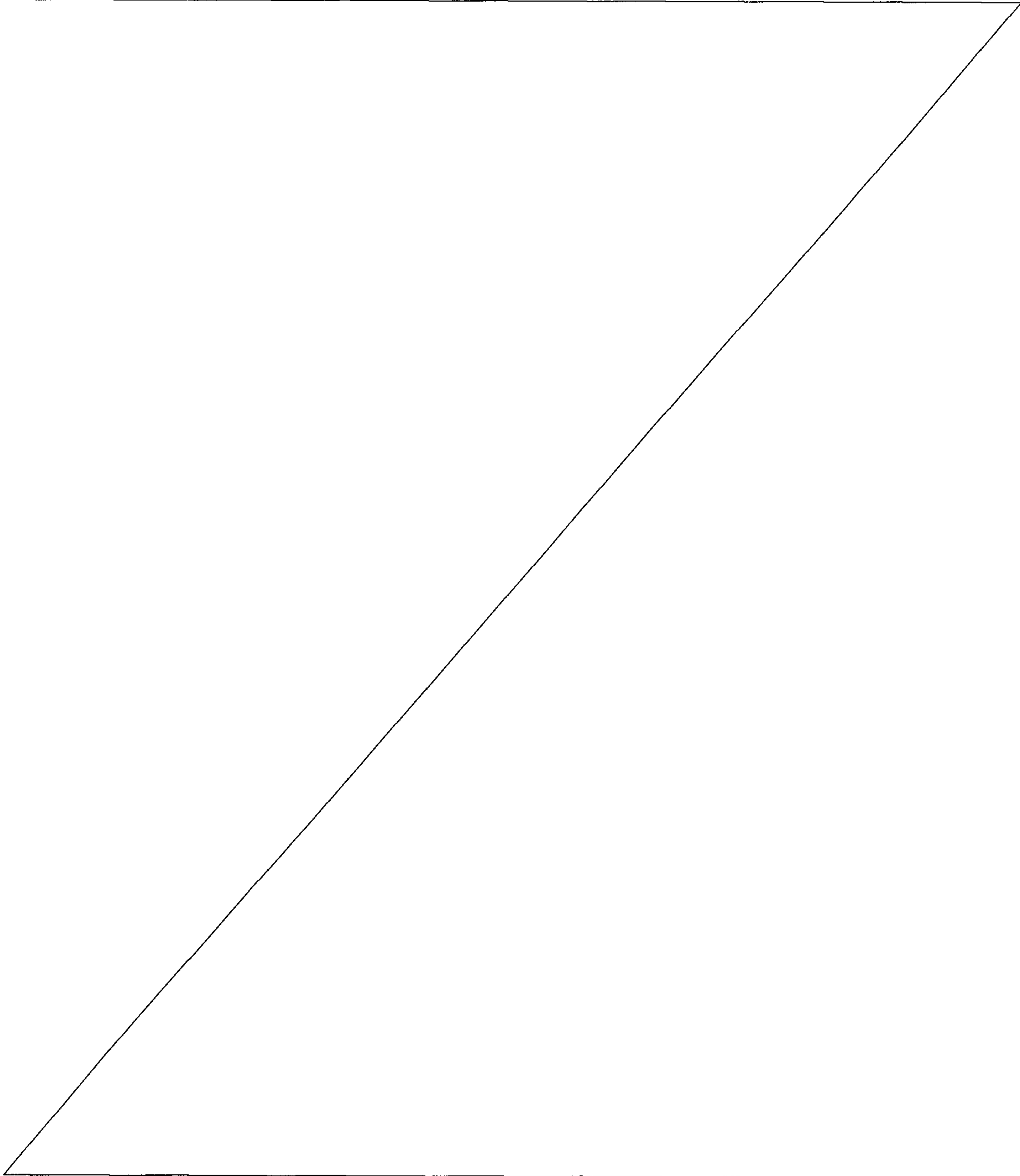

tubesheets (3), whereas the second tubular body (7) envelopes in a gas proof way the outlet tubesheets (4). The axes of the bodies form an angle α of about 45° . The direction fins (8) are situated on the transversal section of the first tubular body, at the intersection of the two axes.

The functioning of the mixing device, object of present invention, is evident from the enclosed scheme and the above description.

One gas is fed to the first tubular body (6), for example steam at a high temperature, through the feeding section A. Another gas is fed to the second tubular body (7), for example ethylbenzene at a high temperature, through the feeding section B.

The steam is uniformly distributed inside the mixing tubes (2) thanks to the directional fins (8) which allow a homogeneous distribution of steam in each tube of the mixer.

Ethylbenzene is fed to the second tubular body, at a pressure slightly higher than that of the steam feeding, so that it penetrates inside the mixing tubes through the holes (5). The ethylbenzene is entrained by the steam inside the tubes where, thanks to the turbulent diffusivity on a reduced scale of the tube diameter, the close mixing of the two gases is obtained.

The gas mix is discharged through the exit section C and fed to the reaction reactor (not shown).

EXAMPLE

A bundle of 100 tubes, each having a conical longitudinal section (1), with a length of 1.2 m, an average inner diameter of 10 cm, is inserted in a tubular body or closed casing (7) of 8 m³. The initial portion of each tube, 50 cm long, contains 10 holes (5), each 15 cm², homogeneously distributed on the surface of the initial portion of the tube (2).

Water vapour is fed at 700°C inside the tubes by means of the feeding section (A) of a tubular body (6) situated on one side of the mixer. Ethylbenzene is charged, at a temperature of 500°C, by means of a feeding section (B) positioned on the casing (7), a pressure of ethylbenzene of 0.08 MPa being maintained inside the casing.

A gaseous mix is discharged at the outlet of the tubes (C), which is directly fed to a dehydrogenation reactor operating under the following conditions:

Catalyst: iron oxides, potassium oxides;

Temperature: 600°C;

Pressure: 0.06 MPa;

Steam/ethylbenzene ratio: 1.45; LHSV: 0.95 h⁻¹.

A flow-rate of 23,500 kg/h of styrene with a selec-

tivity of 95.3% is obtained at the outlet of the dehydrogenation reactor.

The same flow-rates of steam and ethylbenzene, substantially under the same thermodynamic conditions mentioned above, are fed to a traditional mixer consisting of a single tube, 1.5 m long, with an inner diameter of 200 cm equipped with a side inlet.

The steam is fed to the main inlet of the tube, whereas ethylbenzene is fed from the side inlet.

At the end of the tube, is installed a static mixer consisting of 4 mixing layers, each 0.60 m high (for a total of 2.4 m) and with a diameter of 210 cm. The mixture thus obtained is fed to the dehydrogenation reactor which operates under the same conditions indicated above.

23,500 kg/h of styrene are obtained, with a selectivity of 94.4% (with a higher consumption of ethylbenzene of about 10 kg for each ton of styrene produced), or with an alternative running condition, it is possible to obtain 23,500 kg/h of styrene, with a selectivity of 95.3% but an additional steam consumption of about 5,000 kg/h.

WHAT IS CLAIMED IS:

1. A mixing device for two gases comprising:

- a. a plurality of tubes arranged in a bundle, each provided, in its initial portion, with a plurality of side holes;
- b. a first feeding system of one of the two gases, comprising a first tubular body situated on the inlet side of the tubes; and
- c. a second feeding system of the other gas comprising a second tubular body that envelopes in a gas-proof way the tube bundle and at least a portion of the first tubular body;

characterized in that:

- d. the first feeding system of one of the gases comprises a plurality of fins, inside the first tubular body, which allow a uniform distribution of the feeding gas to the single tubes;

and further characterised in that the tubes of the tube bundle are conical, diverging from the inlet towards the outlet.

2. The device according to claim 1, wherein the plurality of holes is present on the initial portion of each tube of the tube bundle, ranging from about 10 to 50% of the total length.

3. The device according to claim 1 or 2, wherein all the holes of the tubes of the tube bundle have surface ranging from 5 to 50 cm².

4. The device according to claim 3, wherein the axis of the holes is perpendicular to the axis of the relative tube, or it forms an angle with the latter ranging from 30 to 60°.

5. The device according to any one of claims 1 to 4, wherein the tube bundle is contained between two inlet and outlet tubesheets.
6. The device according to any one of claims 1 to 5, wherein the first feeding system comprises a first tubular body which is coupled and seal-fixed to the tube sheet at the inlet of the tube bundle.
7. The device according to any one of claims 1 to 6, wherein the second feeding system comprises a second tubular body which envelopes in a gas proof way the tube bundle on the outlet tubesheet, so as to englobe said tube bundle and the first tubular body.
8. The device according to any one of claims 1 to 7, wherein the first tubular body and the second tubular body are coaxial.
9. The device according to any one of claims 1 to 7, wherein the axis of the first tubular body forms with the axis of the second tubular body an angle α ranging from 0 to 90°, or from -90 to 0°.
10. The device according to any one of claims 1 to 9, wherein the fins of the first feeding system consist of thin arc-shaped plates, with a centre angle β ranging from 0 to $\alpha + 10^\circ$ when α ranges from 0 to 90°, or the symmetric correspondent, when α ranges from -90 to 0°.
11. A process for the mixing of two gases, comprising:
 - i. arranging a bundle of tubes having a conical section diverging from the inlet towards the outlet, equipped with a plurality of side holes in their initial part, in a sealed casing with a feeding section of one of the two gases;

- ii. feeding in continuous, inside each tube, the second of the two gases through a feeding system including a tubular body and, in its interior, a plurality of directional fins which allow the uniform distribution of the stream of said second gas inside the single tubes;
- iii. feeding in continuous said first gas inside the closed casing through the feeding section; and
- iv. maintaining, inside the closed casing, a pressure of the gas which is such as to allow said first gas to flow inside said tubes, through the side holes.

12. The process according to claim 11, wherein one of the two gases is steam at a temperature ranging from 550 to 900°C whereas the other gas is ethylbenzene pre-heated to 400-600°C.

