

(No Model.)

E. BUCKLEY.
CAR COUPLING.

No. 525,529.

Patented Sept. 4, 1894.

Fig. 1.

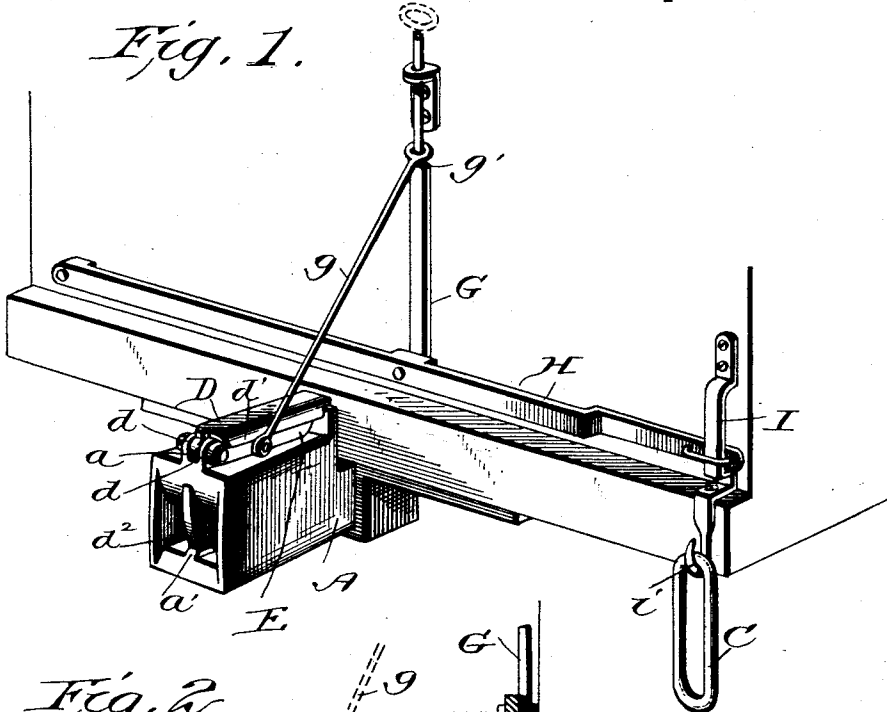

Fig. 2.

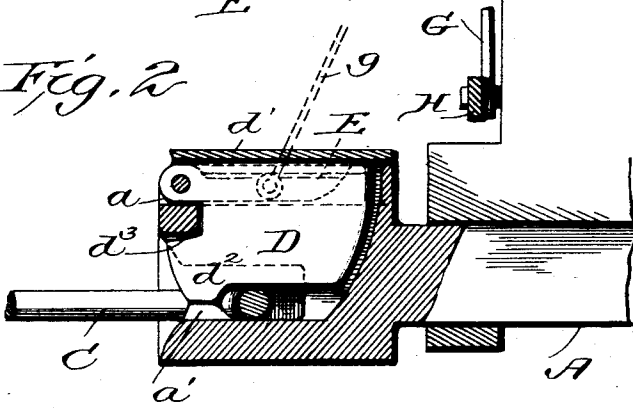

Fig. 3.

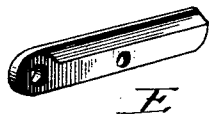
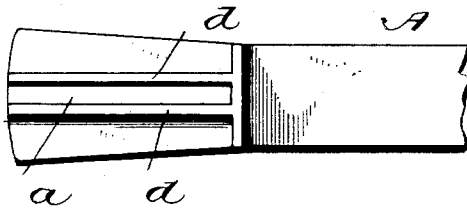

Fig. 4.

Witnesses
Wm. H. Hillyard
Van Buren Hillyard.

Inventor
Edmond Buckley
By Attorneys *Robt. A. Lacey*

UNITED STATES PATENT OFFICE.

EDMOND BUCKLEY, OF SWAN, IOWA, ASSIGNOR OF ONE-HALF TO ALONZO B. MCDANIEL, OF SAME PLACE.

CAR-COUPLING.

SPECIFICATION forming part of Letters Patent No. 525,529, dated September 4, 1894.

Application filed January 27, 1894. Serial No. 498,219. (No model.)

To all whom it may concern:

Be it known that I, EDMOND BUCKLEY, a citizen of the United States, residing at Swan, in the county of Marion, State of Iowa, have invented certain new and useful Improvements in Car-Couplings; and I do hereby declare the following to be a full, clear, and exact description of the invention, such as will enable others skilled in the art to which it appertains to make and use the same.

My invention relates to car couplers which are automatic in their action and couple when the cars are run together, the uncoupling being effected from the top or either side of the car without the necessity of the brakeman going between the cars to effect such result.

The improvement consists of the novel features and the peculiar construction and combination of the parts which will be hereinafter more fully described and claimed and which are shown in the annexed drawings, in which—

Figure 1 is an end view of a car showing the application of my invention. Fig. 2 is a central longitudinal section of the draw bar showing the link held in a horizontal position by means of the gravity latch. Fig. 3 is a top plan view of the draw bar, the gravity latch and lifting bar being detached. Fig. 4 is a detail view of the lifting bar showing its relative disposition.

The draw bar A is attached by its shank portion to the car in any of the well known ways and is chamfered at its projecting or forward end to receive the coupling link C which is of the ordinary form. The upper or top side of the draw bar is provided with a slot *a* through which works a gravity latch D that is pivoted at its upper front corner to the upper side front end of the said draw bar. Parallel extensions *d* extend vertically from the top side of the draw bar, one on each side of the slot *a* to form guides for the gravity latch D, the latter being pivoted to the front end of the said extensions *d*.

The gravity latch D is provided with a cap or head piece *d'* which extends over the extensions *d* and limits the downward movement of the said gravity latch and prevents the entrance of water, ice, snow or other for-

eign matter into the draw bar through the slot *a*. The edge portions of the cap or head piece *d'* curve downward to embrace the side of the extensions *d* and serve the better to shed water and other foreign matter. This gravity latch extends across the throat of the draw bar and is provided at its lower edge with a nose portion *d²* which touches a vertical extension *a'* on the bottom wall of the draw bar. The front edge of the gravity latch is provided with a notch *d³* which when the said gravity latch is at its lowest position receives the front portion of the draw bar closing the forward end of the slot *a*. This construction steadies the said latch and holds it in position against the strain on the link when the coupling is in efficient service.

A lifting bar E is pivoted at one end to the draw bar, preferably to one of the extensions *d* and is adapted to engage with the cap or other projecting portion of the gravity latch and elevate the latter on turning the said lifting bar on its pivot. The lifting bar is beveled outward on its upper edge and comes beneath the portion of the cap *d'*, which latter forms a housing and prevents the lodgment of foreign substances between the said lifting bar and the extension *d* to which it is pivotally connected. Any suitable devices may be provided to operate the lifting bar to effect the uncoupling of the car. As shown, a link *g* is pivotally connected with the lifting bar and has connection with a vertical rod G, the latter being pivoted at its lower end to the horizontal lever H. A shoulder or stop *g'* on the vertical rod G engages with the upper end of the link *g* and causes an upward movement of the same when operating either the lever H or the rod G as will be readily understood.

A strap iron or bar I is located at one side of the car and is constructed to form a keeper and guide the free end of the lever H in its movement. The lower end of this iron I is provided with a hook *i* on which is placed a link C in convenient reach to be used in coupling the cars.

Having thus described my invention, what I claim, and desire to secure by Letters Patent, is—

1. In a car coupling the combination of a

- draw bar having a slot in its top side, and having vertical extension bordering on the said slot, a gravity latch adapted to work through the said slot and guided in its movement by the said vertical extension, and having a cap or head piece extending over the upper edges of the said vertical extensions, and means for operating the said gravity latch, substantially as set forth.
2. In a car coupling, the combination with a draw bar having an opening in its top side, of a gravity latch adapted to work through the said opening and having a cap or top piece, and a lifting bar constructed to engage with the said cap and effect a lifting of the said gravity latch, substantially as set forth.
3. In a car coupling the combination of a draw bar having an opening in its top side and a vertical extension on its bottom wall, a gravity latch pivoted at its upper corner and having notches d^3 in its front edge, a nose d^2 at its lower edge, and having a cap d' , and a lifting bar adapted to engage with and protected by the said cap, substantially as described for the purpose specified.

In testimony whereof I affix my signature in presence of two witnesses.

EDMOND BUCKLEY.

Witnesses:

M. F. HENRY,
S. W. SCHIENER.