





March 16, 1965

J. J. A. BEYL

3,173,701

SAFETY BINDINGS FOR RELEASABLY LOCKING THE HEELS OF SKI BOOTS

Filed April 8, 1963

4 Sheets-Sheet 3

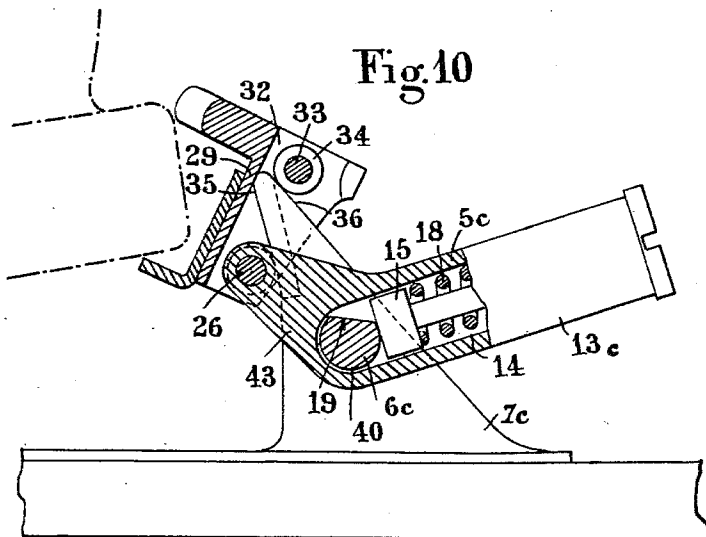
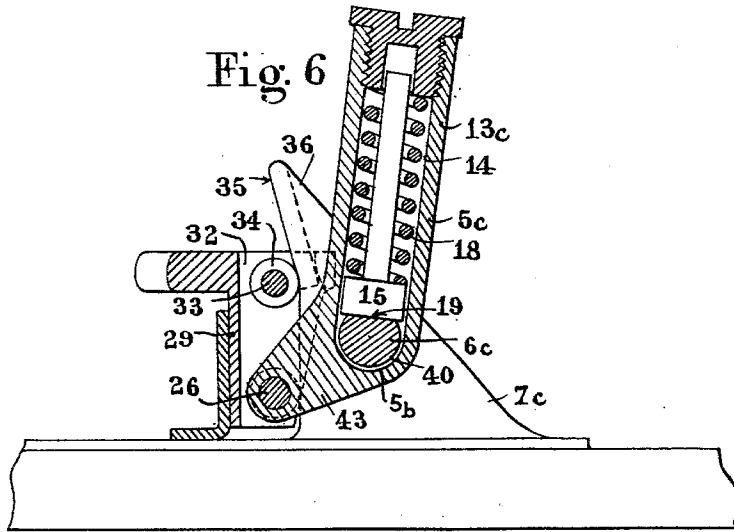

INVENTOR

JEAN J. A. BEYL

By

Berman & Berman  
ATT'YS



3,173,701

**SAFETY BINDINGS FOR RELEASABLY LOCKING THE HEELS OF SKI BOOTS**

Jean Joseph Alfred Beyl, Rue des Champs-Ferrand, Nevers, France

Filed Apr. 8, 1963, Ser. No. 271,143

Claims priority, application France, Apr. 13, 1961, 892,948, Patent 1,294,261; Apr. 11, 1962, 858,621

5 Claims. (Cl. 280—11.35)

This application is a continuation-in-part of Serial No. 184,700 filed April 3, 1962 and now abandoned.

This invention relates to ski bindings in general, notably of the heel-type to be mounted on a ski for releasably locking the heel of a ski boot while urging the boot forward against a front binding for holding the toe end of the ski boot. More particularly, this invention relates to a ski binding of the type adapted automatically to release the heel of the ski boot if the skier falls, in order to avoid any abnormal and dangerous stretching of the skier's leg or foot.

Many safety bindings of this general character have already been proposed, but they are not fully satisfactory. Some hitherto known devices consist of an arm or like retaining member pivoting about a horizontal axis and having its front end locked by spring means against the rear portion of the boot, or against a member secured thereon. A suitable mechanism is provided in this case for controlling the tension of these spring means and positioning the retaining member on the rear edge of the ski boot. However, these mechanisms are rather complicated and liable to failure. Their operation is scarcely reliable, in as much as they are unprotected and their movable components are liable to become jammed by frost or snow. Besides, the springs themselves are unprotected and their operation may also be impaired by frost or snow. Also, these known mechanisms are awkward to operate, and this is a serious drawback since they are located at the rear of the skier's boot.

In addition, these former devices cause a complete and sudden release of the heel as a consequence of a sudden lifting movement resulting from a forward fall. But in case of minor stress they are generally not capable of permitting a free partial upward movement of the heel, which would be sufficient in many cases, followed by an automatic return of the heel to its normal position.

Finally, when these prior art devices are used in conjunction with a safety binding retaining the toe end of the boot they interfere with the proper operation of this safety binding. In fact, bindings of this character are designed with a view to release the toe end of the ski boot when an abnormal torsional stress is applied thereto, the boot pivoting about its rear or heel portion. On the other hand, to facilitate this pivotal movement most front bindings of this type are associated with a turntable fitted under the heel of the boot to permit its free rotation.

Now hitherto known heel-type safety bindings cannot be mounted on a turntable of this character. Under these conditions, due to their fixed position on the ski, they interfere with the proper operation of the front binding.

It is therefore an essential object of this invention to provide a heel-type releasable ski binding having a safety feature and so designed that it cannot interfere in any way with the free rotation of the boot about its rear portion, this device being intended for use more particularly in combination with a front binding adapted to release the boot in case of abnormal torsional stress. This device is so designed that if necessary it can be mounted on a rotary plate or turntable mounted under the heel

of the ski boot. It is another object of this invention to provide a safety binding of the type set forth which is particularly simple in design and easy to operate, wherein all the movable components are efficiently protected against frost and snow, so that the operation of the device is particularly reliable and so arranged that the heel of the ski boot can be lifted partially in case of mid-strength efforts, following which the heel is returned automatically to its normal position.

To this end, this invention provides a safety device for releasably locking the rear or heel end of a ski boot which comprises a retaining member pivotally mounted on a horizontal pin disposed behind the heel and carrying on its front face means for gripping the rear or heel end of the boot, and a spring loaded mechanism comprising a movable piston resiliently urged against a flat seat and so maintaining said pivoted member that said gripping means bear against the boot. According to an essential feature characterizing this device, the piston and spring assembly is mounted in the body of said pivoted member and the latter acts as a control arm extending upwardly and obliquely behind the boot when the device is in its operative position, the flat seat engaged by said piston being formed on the pivot pin of said pivoted member.

In a particular form of embodiment, the pivoting retaining member comprises on its front face a special gripping member adapted to engage and lock the rear edge of the sole of a ski boot, this gripping member being pivotally mounted, guide means being provided on said fixed support for guiding this gripping member during the first portion of its movement so that this portion will be coincident with the normal path of the heel in case of upward movement thereof, the resilient means of the device constantly urging said pivoting retaining member and said gripping member in their normal holding position during this first portion of the gripping movement.

A few typical forms of embodiment of the safety heel-type ski binding according to this invention will be described hereafter by way of example with reference to the attached drawings wherein:

FIGURE 1 is a vertical section showing the safety binding of this invention carried by a rotary plate mounted on the ski;

FIGURE 2 is a plan view from above of the same device;

FIGURE 3 is a fragmentary section similar to FIG. 1 but illustrating the operation of the safety device when the rear portion of the boot is lifted;

FIGURE 4 is a fragmentary section showing a detail on a larger scale;

FIGURE 5 is a perspective view showing an alternate embodiment;

FIGURES 6 and 7 are a vertical section and a side-elevational view respectively of another form of embodiment;

FIGURE 8 is a plan view from above showing the same device;

FIGURE 9 is a section taken upon the line IX—IX of FIG. 7;

FIGURE 10 is a view similar to FIG. 6, showing the device during its operation.

The heel-type ski binding according to this invention is adapted to be used in combination with a front ski binding adapted to automatically release the toe end of the ski boot when the latter tends to rotate under the influence of an abnormally strong torsional effort. This front ski binding may comprise an abutment 1 rotatably mounted on a vertical pin 2 carried by a base plate 3 secured on the ski 4. However, this front ski binding is not con-

sidered herein as being part of the invention and may be of any other similar or different type.

FIGS. 1 to 4 of the drawings illustrate a first form of embodiment of the device. In this specific embodiment, the device consists essentially of a hook-like retaining member 5 formed on its front face with a retaining or hooking catch 20. This member is pivoted about a fixed horizontal pin 6 carried in turn by a pair of vertical lugs 7. This pin 6 is parallel to the upper face of the ski but extends in a direction at right angles to the longitudinal axis of the ski. This pin engages in a transverse bore 5b formed through the retaining member 5. The support 7 is solid with a rear extension 8 of a swivel plate 9 rotatably mounted under the heel of boot C and retained on the ski by a circular plate 11 secured by means of screws 12.

The rotary hook 5 carries an extension 13 of substantially cylindrical configuration formed with an inner axial bore 14 communicating with the transverse bore 5b engaged by the pivot pin 6. Slidably mounted in this axial bore 14 is a piston 15 provided with a rod 16 having its free end slidably mounted in turn in a blind hole formed in a plug 17 screwed in the outer end of extension 13.

Surrounding the rod 16 is a coil compression spring 18 with one end bearing against the aforesaid plug 17 and with the opposite end bearing against the piston 15 to urge the same against a fixed flat seat 19 consisting of a flat face formed on the adjacent side of pin 6.

As will be readily understood from the figures, the spring 18 constantly urges the flat face of piston 15 for tight engagement with the flat seat 19. By construction this seat is disposed in a substantially horizontal plane whereby the action of spring 18 tends to keep the extension 13 of the rotary hook in a substantially vertical position behind the boot C with the gripping projection 20 facing forwards.

This extension 13 acts somewhat as a lever whereby the hook 5 can be moved by hand without difficulty to rotate same about its pin 6 in the direction of the arrow F against the pressure exerted by the coil spring 18.

The gripping projection 20 carried by the rotary hook 5 is adapted to engage a natural shoulder formed at the rear of the skit boot, for example the rear upper edge of the heel or a bearing member secured on the rear face of the heel as in the example illustrated. This bearing member may consist of a strap 21 secured by screws or otherwise on the heel and carrying a pair of parallel lugs 22 extending rearwardly and receiving a substantially horizontal pin 23 between them. The gripping projection 20 is thus adapted to engage this pin.

To secure the skiboot C on the ski, the rotary hook 5 is first rotated in the direction of the arrow F to direct the gripping projection 20 upwards, this movement being affected very easily by actuating the lever 13 manually. Then the boot can be positioned on the ski, its toe end being subsequently engaged under the abutment member or rotary endpiece of the front binding. It will be noted that the rotary hook 5 remains automatically in its retracted position during this operation, for the piston 15 of the resilient return system engages the rear rounded face 40 of pin 6. When the boot is thus properly positioned, the user simply raises the lever 13 to cause the gripping projection 20 thereof to engage the transverse pin 23 of the strap secured on the boot. In fact, the action of the coil spring 18 in the resilient return system will then tend to keep the gripping projection 20 on the transverse pin 23 with the rear portion of the boot tightly pressed on the ski. However, when a considerable upward and forward stretching effort is applied to the skier's leg, for instance in case of a forward fall of the skier, the heel of the boot is caused to rise in the direction of the arrow F<sub>1</sub>, as shown in FIG. 3 thus lifting the gripping projection 20 of the rotary hook 5. Of course, this movement takes place against the resistance of spring 18.

Under these conditions, two facts should be considered:

(1) If the stretching effort applied to the skier's leg is of moderate magnitude and short duration, the heel will be lifted to a small extent, but the gripping extension 20 will remain constantly engaged with the pin 23 of the strap secured on the boot. Under these conditions, when the stretching effort ceases, the spring 18 of the resilient system associated with the hook 5 will automatically return the latter to its initial position and restore the heel to its normal position against the ski. Thus, the device of this invention permits a partial lifting movement of the heel which is sufficient to avoid the detrimental consequences of a rigid fastening of the heel on the ski. After this lifting movement the boot is again lowered and remains safely secured on the ski, so that the skier may continue skiing without having to actuate the binding.

(2) If a relatively strenuous stretching effort is exerted on the leg, the lifting movement of the heel relative to the ski is more important than in the preceding case. The bearing pin 23 associated with the rotary hook will then move the gripping projection 20 to a degree sufficient to escape therefrom (see FIG. 3). Thus the heel is released completely by the binding whereby the skier's leg will not be subjected to any dangerous stretching effort in case of forward fall.

It should be noted more particularly that this binding does not interfere with swivelling movements of the boot about its heel when the front binding 1 releases the boot as a consequence of an abnormal torsional stress. In fact, the complete device will then rotate bodily with the rotary plate 9 to follow the movement of the boot heel. Thus, this device permits a perfect operation of the front binding, as contrasted with most heel-type bindings.

By screwing the plug 17 more or less it is possible to adjust the compression of spring 18 and thus preset the conditions of operation of the device.

According to another feature of this device, the front face of the rotary hook 5 is formed with a cam face adapted to push the boot C forwards when the rotary hook is moved to its boot-locking position.

This cam face may consist simply of a circular contour 24 having a certain degree of eccentricity in relation to the center O of pin 6 about which the hook body 5 rotates. The shape of this contour is clearly visible in FIG. 4 wherein the curve in chain-dotted lines corresponds to a circular arc centered on O and extending from the rear face of the hook body. The front end of the cam face 24 is thus shifted forwards by a distance *d* in relation to this circular arc.

When the hook 5 is raised to its retracted position the cam face 24 is somewhat retracted, whereby a play results between the hook 5 and the rear end of the boot, this play being sufficient to facilitate the proper positioning of the boot. On the other hand, when the lever 13 is subsequently pulled to its upstanding position to bring the gripping projection 20 to its engaged position, the cam face 24 will slide along the pin 23 of the bearing member to move this member forwards through the above-defined distance *d*. Thus, the front end of the boot sole is retained under the abutment or end-piece of the front binding without any play.

FIGURE 5 illustrates a modified embodiment of the preceding device shown in FIGS. 1 to 4. This alternate embodiment is adapted to retain in position the rear end of a ski boot without necessitating the provision of a bearing member thereon such as the strap 21 of the preceding form of embodiment. To this end, the gripping projection of the pivoting retaining member 5a consists of two arcuate arms 20a between which a roller 25 is rotatably mounted, as shown. This arcuate device is adapted to bear directly on the upper edge of the rear end of a boot sole or heel, its shape accommodating the curvature of this end portion. The structure of the device is generally the same as that of the device indi-

5

cated in FIGS. 1 to 3, and its operation is also the same.

FIGURES 6 to 9 illustrate a further form of embodiment of the device according to this invention. In this modified embodiment the device comprises a gripping member adapted to engage the rear portion of a boot sole. The piston and the spring of the resilient return system are disposed in the pivoting retaining member, which is similar to that provided in the embodiment shown in FIGS. 1 to 3. Thus, it is rotatably mounted about a horizontal transverse pin 6c carried by a pair of lateral upstanding flanges 7c solid with a stationary strap-like base member. The retaining member 5c is formed with an extension 13c having an inner cylindrical cavity 14c slidably engaged by the piston 15 urged by the compression spring 18 of the resilient return system. This piston 15 thus engages a flat seat 19 formed on the transverse pin 6c and so oriented that the extension 13c is directed upwards, at a small angle to the vertical, when the device is in its normal operative position (FIGS. 6 and 7).

This device comprises a special gripping member 29 adapted to engage the rear portion of a boot sole. The lower portion of this member is pivoted about a horizontal pin 26 carried by an extension 43 of the pivoted retaining member 5c. This pin is mounted between a pair of vertical lugs 32 extending backward from the gripping member 29. Between the upper ends of these lugs extends another pin 33 on which a roller 34 is rotatably mounted. This roller 34 engages a race 35 formed on the front edge of an upwardly directed projection 36 extending from the aforesaid flanges 7c of the base member. This race 35 has a contour adapted to ensure a first displacement of the gripping member 29 which is coincident with the normal path followed by the heel during its initial upward movement.

The upper ends of the two vertical lugs 32 are each formed with a hook-like inwardly bent portion 37, the two bent portions 37 being disposed behind a pair of outwardly bent portions 38 of the upstanding flanges of the base member 7c to prevent the forward movement of the gripping member 29.

The device of this embodiment operates as hereinabove described: as a consequence of an effort tending to lift the rear end of the ski boot, the gripping member 29 is lifted bodily therewith and carries along the retaining member 5c. This member rotates about the pin 6c which is stationary. This movement is attended by a backward movement of the piston 15 against the resistance of spring 18, as in the device shown in FIGS. 1 to 3 and described hereinabove.

The gripping member 29 will thus perform a first displacement coincident with the normal path of the heel movement until the roller 34 clears the top of the race 35. As in the preceding case, this position is substantially coincident with the moment when the piston begins to engage the round surface 40 of pin 6c. Then the resilient system will no more tend to restore the pivoting retaining member 5c to its initial position and this member can continue its rotation, the gripping member 29 tilting backwards (see FIG. 10). The roller is now disposed on the rear face of the projection 36.

The device constituting this alternate form of embodiment of the invention is also advantageous in that it permits of dispensing with the use of a special bearing member secured on the rear end of the boot. Nevertheless it ensures a particularly reliable retaining action on the boot, without damaging the boot material, unlike most of the hitherto known devices of this character. This is due to the provision of the pivoted gripping member 29 and more particularly to the guiding action applied thereto during a first portion of its movement which is coincident with the normal path of the heel when the latter is lifted off the ski. Thus, the upper portion of the guide race 35 is slightly inclined to produce a corresponding slight inclination of the gripping member 29, for the normal bend-

6

ing of the ski boot involves a moderate inclination of the heel. Under these conditions, the gripping member 29 will follow exactly the heel of the ski boot during its movement and will not slide on, or otherwise engage, the leather or other boot material and damage same each time the boot is lifted.

The manual operation of the device is as easy as in the case of the device illustrated in FIGS. 1 to 3, for the extension 13c of the pivoting retaining member constitutes a kind of control lever. As in the preceding device, the form of embodiment illustrated in FIGS. 6 to 10 is adapted to be mounted on the extension 8 of a swivel plate 9 underlying substantially the boot heel. However, this device could also be mounted permanently on the ski, although this solution is less advantageous for the reasons set forth before. In any case; the base member 7c of the device of FIGS. 6-10 and the base member of the device of FIG. 5, as well as the base member 7 of the device of FIGS. 1 to 3, may advantageously be mounted in horizontal slideways permitting the longitudinal adjustment of the position of the device by means of a screw, according to the boot size.

Of course, this device should not be construed as being limited to the specific forms of embodiment shown, illustrated and suggested herein, as many modifications and variations may be brought thereto without departing from the spirit and scope of the invention as set forth in the appended claims.

What I claim is:

1. Safety binding device for releasably locking the heel of a boot on a ski, comprising in combination a pivot pin disposed behind the boot position and parallel to the upper face of the ski but extending in a direction at right angles to the ski axis, means on the ski for supporting said pivot pin said means adapted to prevent said pin from revolving about its axis, a pivoting retaining member having a bore formed therein which is engaged by the said pivot pin, whereby said last-named pivot pin acts as a pivot to said member, means mounted on and ahead of said pivoting member for gripping the rear portion of the heel of the ski boot and holding said rear portion on the ski, an extension on said pivot member which constitutes a manual control lever for rotating said pivoting member, a passage in said extension which communicates with the bore containing said pivot pin, resilient means for interconnecting said pivoting member and said pivot pin, said resilient means being adapted to keep said pivoting member in a position in which said gripping means are in engagement with the rear portion of the boot heel and comprising a piston slidably mounted in said passage formed in said extension of said pivoting member, a flat seat formed on said pivot pin on its upper portion, a compression spring housed in said passage of said extension and adapted to urge said piston against said flat seat, whereby the pressure exerted by said spring-loaded piston on said flat seat tends to keep said pivoting member in a position in which said heel gripping means are in engagement with said rear heel portion and said extension of said pivoting member in a substantially upright position behind the boot.

2. A safety binding device for releasably locking the heel of a boot on a ski, comprising in combination a pivot pin behind the boot position and parallel to the upper face of the ski and extending in a direction at right angles to the ski axis, means secured on the ski for supporting said pivot pin, said means being adapted to prevent the pin from revolving about its axis, a pivoted retaining member having a bore formed in it and engaged by the pivot pin, whereby said last-named pivot pin acts as a pivot for said member, a gripping projection solid with the forward part of the pivoted member and adapted to engage the rear upper edge of the heel to hold said heel on the ski, an extension on said pivoted member constituting a manual control lever for rotating said pivoted member, a passage in said extension communicating with

the bore containing said pivot pin, resilient means between the pivoted member and said pivot pin, said resilient means keeping said pivoted member in a position in which said gripping projection is pressed against a rear upper edge of the heel, and resilient means comprising a piston slidably mounted in said passage formed in said extension of the pivoted member, a flat seat on the upper part of the pivot pin, a compression spring housed in said passage of the extension and adapted to urge said piston against said flat seat, whereby the pressure exerted by said spring-loaded piston on the flat seat tends to keep said pivoted member in a position in which the gripping projection is pressed against the rear upper edge of the heel, and said extension of said pivoted member is located in a substantially upright position behind the boot.

3. A safety binding device for releasably locking the heel of a boot on a ski, comprising in combination a pivot pin disposed behind the boot position and parallel to the upper face of the ski but extending in a direction at right angles to the ski axis, means secured on the ski for supporting said pivot pin, said means being adapted to prevent said pin from revolving about its axis, a pivoted retaining member having a bore formed in it and which is engaged by the said pivot pin, said last-named pivot pin acting as a pivot for said retaining member, means mounted ahead of said pivoted member for gripping the rear portion of the heel of the ski boot and holding said rear portion on the ski, an extension on said pivoted member constituting a manual control lever for rotating the pivoted member, a passage in said extension communicating with the bore containing said pivot pin, resilient means arranged between said pivot member and the said pivot pin, said resilient means being adapted to keep said gripping means in engagement with the rear portion of the boot heel, said resilient means comprising a piston slidably mounted in said passage formed in said extension of the said pivot member, a flat seat formed on the upper portion of said pivot pin, said surface being substantially parallel to the upper face of the ski, a compression spring housed in the passage of said extension and adapted to urge said piston against said flat seat, whereby the pressure exerted by said spring-loaded piston on said flat seat tends to keep said gripping means in engagement with rear heel portion and said extension of said pivoted member in a substantially upright position behind the boot.

4. A safety binding device for releasably locking the heel of a boot on a ski, comprising in combination a pivot pin disposed behind the boot position and parallel to the upper face of the ski but extending in a direction at right angles to the ski axis, means secured on the ski for supporting said pivot pin, said means being adapted to prevent said pin from revolving about its axis, a pivoted retaining member having a bore formed in it and which is engaged by the pivot pin, said last named pivot pin acting as a pivot for said retaining member, a gripping

projection formed solid with the forward part of the pivoted member, said projection engaging the rear upper edge of the heel to hold said heel on the ski, an extension on said pivoted member constituting a manual control lever for rotating said pivoted member, a passage in said extension communicating with the bore containing said pivot pin, resilient means between said pivoted member and said pivot pin, said resilient means keeping said pivoted member in a position in which said gripping projection is pressed against the rear upper edge of the heel and in which part of the heel is substantially parallel to the upper face of the ski, said resilient means comprising a piston slidably mounted in said passage formed in said extension of said pivoted member, a flat seat formed on said pivot pin on its upper portion, a compression spring housed in said passage of said extension and adapted to urge said piston against said flat seat, whereby the pressure exerted by said spring-loaded piston on said flat seat tends to keep said pivoted member in a position in which said gripping projection is pressed against the rear upper edge of the heel and said extension of said pivoted member is located in a substantially upright position behind the boot.

5. A safety binding device for releasably locking the heel of a boot on a ski comprising, a bracket having a pair of lugs projecting upwardly from the top of a ski in a position to the rear of a boot to be placed on the ski, a fixed pivot pin extending between the lugs, said pin having a horizontal flattened surface and an arcuate surface, a cylindrical lever having one end disposed around the pin to pivotally mount the lever on the pin, said lever being formed with a hook for engagement with a heel extension on a boot resting on the ski, a spring-biased piston located within the lever, said piston being in contact with the flat surface on the pivot pin when the hook is fully engaged with the heel extension and engaging the arcuate surface of the pivot pin when said hook is disengaged from the heel extension, and cam means on the lever for engaging against the heel extension to urge the boot forwardly when the lever is moved to its heel-engaging position.

## References Cited by the Examiner

## UNITED STATES PATENTS

2,836,428	5/58	Marker	280—11.35
2,851,278	9/58	Berlenbach	280—11.35
2,867,447	1/59	Mueller	280—11.35
3,027,173	3/62	Beyl	280—11.35

## FOREIGN PATENTS

258,334	1/50	Switzerland.
584,108	10/58	Italy.
1,110,856	10/55	France.
1,190,118	3/59	France.

A. HARRY LEVY, *Primary Examiner.*