

(12) STANDARD PATENT
(19) AUSTRALIAN PATENT OFFICE

(11) Application No. **AU 2016201623 B2**

(54) Title
Endoscopic stapler

(51) International Patent Classification(s)
A61B 17/068 (2006.01)

(21) Application No: **2016201623**

(22) Date of Filing: **2016.03.14**

(30) Priority Data

(31) Number	(32) Date	(33) Country
62/145,857	2015.04.10	US
14/994,228	2016.01.13	US

(43) Publication Date: **2016.10.27**

(43) Publication Journal Date: **2016.10.27**

(44) Accepted Journal Date: **2020.01.02**

(71) Applicant(s)
Covidien LP

(72) Inventor(s)
Kostrzewski, Stanislaw

(74) Agent / Attorney
Spruson & Ferguson, GPO Box 3898, Sydney, NSW, 2001, AU

(56) Related Art
US 5484451 A
US 8485412 B2

ENDOSCOPIC STAPLER

ABSTRACT

A surgical stapler (10) is described herein which includes a shaft portion (112) and a tool assembly (114) supported on a distal end of the shaft portion. The tool assembly includes an anvil (182) and a cartridge body (184) which rotatably supports a plurality of staples (185) within notches (188). At least one firing cam (138a, 138b) is provided to sequentially engage and rotate each of the staples to fire the staples from the cartridge body. The at least one firing cam includes axially offset cam members (222). Each of the staples includes first and second legs (200a, 200b) axially offset from each other and interconnected by an intermediate portion (201).

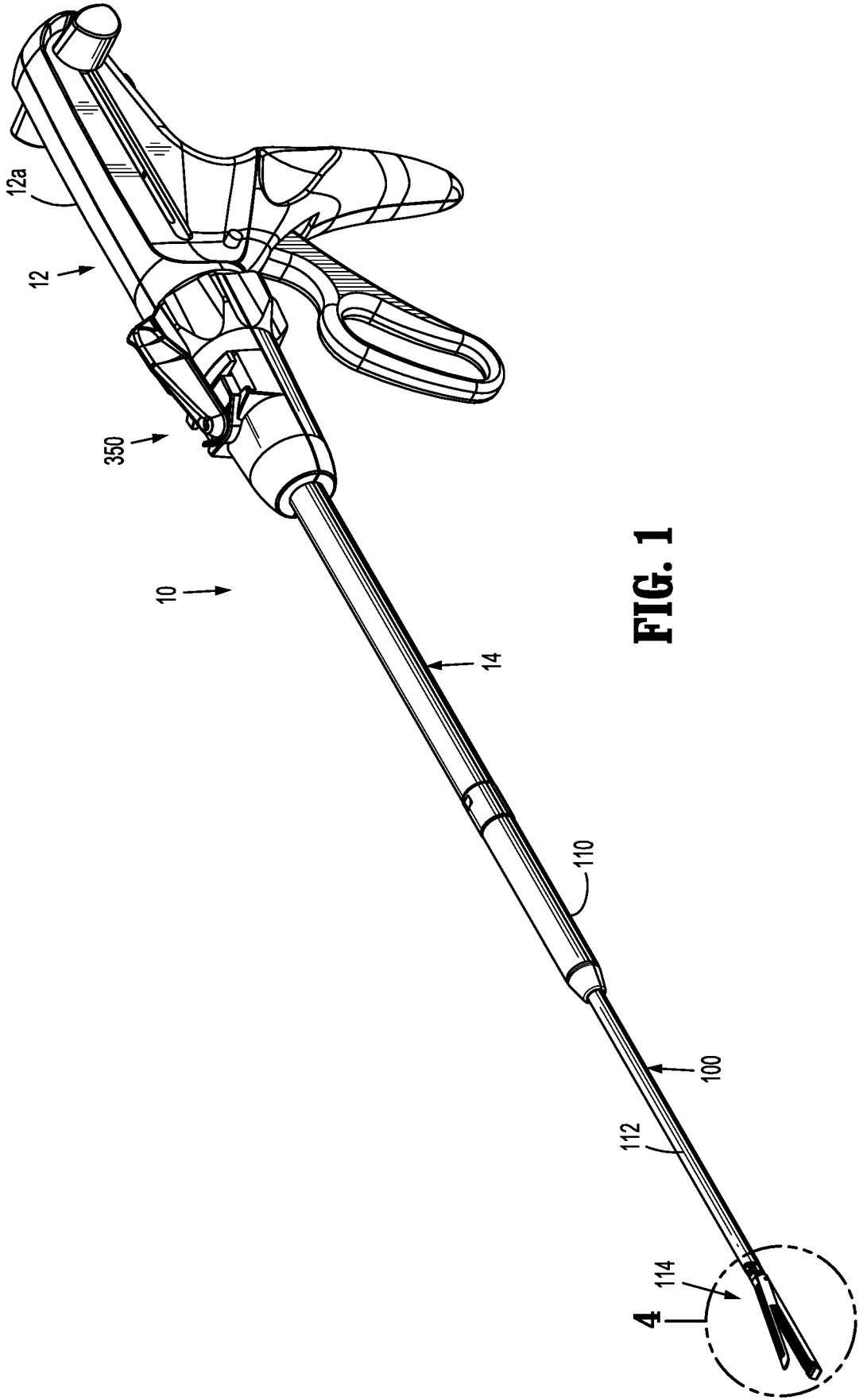

FIG. 1

ENDOSCOPIC STAPLER

Cross-Reference to Related Applications

[0001] This application claims the benefit of and priority to U.S. Provisional Patent Application No. 62/145,857 filed April 10, 2015 and US Patent Application No. 14/994,228 filed 13 January 2016, the entire disclosure of which is incorporated by reference herein.

Technical Field

[0002] The present disclosure relates to surgical staplers, and more particularly, to surgical staplers for endoscopic use. The present disclosure also relates to surgical staples for use with endoscopic surgical staplers.

Background

[0003] Surgical staplers typically include a cartridge housing a plurality of staples, an anvil for forming the staples as the staples are ejected from the cartridge, and a knife to effect simultaneous dissection and suturing of tissue. When compared to applying manually threaded sutures, the use of surgical staplers to suture and dissect tissue has increased the speed of the surgical procedure and thus, minimized patient trauma.

[0004] In an endoscopic surgical procedure, a surgical stapler is inserted through a small incision in the skin or through a cannula to access a surgical site. Due to the complexity of known surgical staplers as well as the staple size requirements of known staple forming apparatus, a continued need exists for small diameter surgical staplers suitable for endoscopic use.

Object

[0005] It is an object of the present invention to substantially satisfy the above need, or at least provide a useful alternative.

Summary

[0006] The present disclosure is directed to a surgical stapler having a tool assembly including an anvil and a staple cartridge having a series of staples which are supported and configured to be rotatably ejected from the staple cartridge into the anvil to suture tissue. The manner in which the staples are supported and ejected from within the staple cartridge facilitates the use of a small diameter tool assembly that includes staples capable of suturing thicker tissues than would normally be associated with tool assemblies with such a small diameter. In embodiments, the surgical stapler includes at least one firing cam having staggered cam members and the staples are configured with staggered legs. Each of the staple legs has a D-shaped configuration when deformed.

[0007] In one aspect of the disclosure, a surgical stapler comprising: a shaft portion; a tool assembly supported on a distal end of the shaft portion, the tool assembly including an anvil and a cartridge assembly, the cartridge assembly including a cartridge body having at least one leg defining a plurality of notches, and a plurality of staples, each of the plurality of staples having an intermediate portion interconnecting first and second staple legs wherein the intermediate portion of each of the plurality of staples is rotatably supported within a respective one of the plurality of notches, has a first end connected to the first leg and a second end connected to the second leg, wherein the first end of the intermediate portion is positioned distally of the second end of the intermediate portion; and at least one firing cam including a distal end defining a cam member having first and second cam surfaces, the first cam surface positioned distally of the second cam surface, the cam member being movable within the tool assembly to move the first and second cam surfaces into sequential engagement with the first and second staple legs, respectively, of each of the plurality of staples, wherein engagement between the cam member and the first and second staple legs of each of the plurality of staples effects rotational movement of each of the plurality of staples about an axis defined by the intermediate portion that is transverse to the longitudinal axis within the respective one of the plurality of notches to fire each of the plurality of staples from the cartridge body

[0008] In embodiments, each notch of the plurality of notches is configured to rotatably support one of the staples of the plurality of staples.

2a

[0009] In some embodiments, the at least one leg of the cartridge body defines a plurality of cutouts. Each of the plurality of cutouts is spaced from adjacent notches of the plurality of notches and is configured to receive a first portion of the intermediate portion of one of the staples of the plurality of staples.

[0010] In embodiments, the intermediate portion of each of the staples is S-shaped and includes a distal U-shaped portion that is configured to be received in a respective one of the cutouts of the plurality of cutouts on the at least one leg of the cartridge body.

[0011] In certain embodiments, each of the notches of the plurality of notches is configured to rotatably receive a proximal portion of the intermediate portion of a respective one of the staples of the plurality of staples.

[0012] In embodiments, the first and second staple legs of each of the staples of the plurality of staples has a curved configuration and each of the first and second staple legs defines a D-shape when formed against the anvil.

[0013] In some embodiments, each notch of the plurality of notches includes a cylindrical slot that is configured to receive the proximal portion of the intermediate portion of a respective one of the staples of the plurality of staples in a snap-fit manner.

[0014] In certain embodiments, the at least one leg of the cartridge body includes two spaced legs and the plurality of notches is spaced axially along each of the two spaced legs, wherein each of the plurality of notches rotatably supports one of the staples of the plurality of staples.

[0015] In embodiments, the surgical stapler includes first and second cartridge channels. Each of the first and second cartridge channels has a distal end defining a U-shaped member and each of the two spaced legs of the cartridge body is secured within a respective one of the U-shaped members.

[0016] In some embodiments, the at least one firing cam includes first and second firing cams. Each of the cam members of the first and second firing cams has a U-shape and is positioned about one of the two spaced legs of the cartridge body and within the U-shaped member of one of the first and second cartridge channels.

[0017] In certain embodiments, the surgical stapler includes a pivot member pivotably secured to the distal end of the shaft portion and fixedly secured to each of the first and second cartridge channels.

[0018] In embodiments, the surgical stapler includes a first articulation link having a distal end secured to a proximal end of the first cartridge channel and a second articulation link having a distal end secured to a proximal end of the second cartridge channel. The first and second articulation links are axially movable to effect axial movement of the first and second cartridge channels in relation to each other to pivot the pivot member in relation to the shaft portion.

[0019] In some embodiments, a pivotable articulation member interconnects the first articulation link to the second articulation link such that movement of the first articulation link in one direction effects movement of the second articulation link in an opposite direction.

[0020] In certain embodiments, each of the first and second staple legs of each of the plurality of staples has a tapered tip.

[0021] In embodiments, the at least one leg of the cartridge body includes a plurality of dimples and each of the plurality of dimples is positioned to engage one of the first and second legs of one of the staples of the plurality of staples to stabilize the staple on the cartridge body.

[0022] In another aspect of the disclosure, a surgical staple is described that includes a first curved leg, a second curved leg, and an intermediate portion interconnecting the first curved leg to the second curved leg. The intermediate portion of the staple has a first end connected to the first curved leg and a second end connected to the second curved leg, wherein the first and second ends of the intermediate portion are axially offset from each other.

[0023] In some embodiments, the intermediate portion of the staple is S-shaped and includes a distal U-shaped portion and a proximal portion.

[0024] In certain embodiments, each of the first and second legs includes a tapered tip.

[0025] In embodiments, the first and second legs of the staple is configured to have a D-shape when formed against an anvil.

Brief Description of the Drawings

[0026] Preferred embodiments of the present invention will now be described, by way of examples only, with reference to the accompanying drawings, wherein:

[0027] FIG. 1 is a side perspective view of one embodiment of the presently disclosed small diameter surgical stapler in an unapproximated position;

[0028] FIG. 1A is a side perspective view from the distal end of a stapler reload of the surgical stapler shown in FIG. 1;

[0029] FIG. 2 is a side perspective view from the proximal end of the surgical stapler reload shown in FIG. 1A;

[0030] FIG. 3 is a side perspective, exploded view of the surgical stapler reload shown in FIG. 1A;

[0031] FIG. 3A is a top, perspective, exploded view of a distal end of the upper housing half-section of a proximal body portion, a pivot member, and a connecting member of the surgical stapler reload shown in 3;

[0032] FIG. 3B is an enlarged view of the indicated area of detail shown in FIG. 3;

[0033] FIG. 3C is an enlarged view of the indicated area of detail shown in FIG. 3;

[0034] FIG. 4 is an enlarged view of the indicated area of detail shown in FIG. 1;

[0035] FIG. 5A is a perspective view from one side of a staple of the stapler reload shown in FIG. 3;

[0036] FIG. 5B is a top view of the staple shown in FIG. 5A;

[0037] FIG. 5C is a perspective view from the other side of the staple shown in FIG. 3;

[0038] FIG. 6 is an enlarged view of the indicated area of detail shown in FIG. 3C;

[0039] FIG. 7 is an enlarged view of the indicated area of detail shown in FIG. 6;

[0040] FIG. 7A is a top view of the cartridge assembly of the surgical stapler reload shown in FIG. 1A;

[0041] FIG. 7B is an enlarged view of the indicated area of detail shown in FIG. 7A;

[0042] FIG. 8 is a side, cutaway view of the cartridge body supporting a staple;

[0043] FIG. 9 is a side, perspective view of a cartridge channel of the stapler reload shown in FIG. 3;

[0044] FIG. 10 is a top view of the cartridge channel shown in FIG. 9;

[0045] FIG. 11 is an enlarged view of the indicated area shown in FIG. 10;

[0046] FIG. 12 is an enlarged view of the indicated area of detail shown in FIG. 9;

[0047] FIG. 13 is a perspective, cross-sectional view taken along section line 13-13 of FIG. 12.

[0048] FIG. 14 is a side, perspective view of a staggered firing cam of the stapler reload shown in FIG. 3;

[0049] FIG. 15A is an enlarged view of the indicated area of detail shown in FIG. 14;

[0050] FIG. 15B is a top view of the distal end of the staggered firing cam shown in FIG. 14;

[0051] FIG. 16 is a perspective, cross-sectional view taken along section line 16-16 of FIG. 15;

[0052] FIG. 17 is a side, perspective view of the cartridge assembly of the stapler reload shown in FIG. 3 supported on a distal end of the firing cams;

[0053] FIG. 18 is an enlarged view of the indicated area of detail shown in FIG. 17;

[0054] FIG. 19 is a side, perspective view of the cartridge assembly of the stapler reload shown in FIG. 3 supported on the distal ends of the cartridge channels and firing cams;

[0055] FIG. 20 is an enlarged view of the indicated area of detail shown in FIG. 19;

[0056] FIG. 21 is a top view of the stapler reload shown in FIG. 1A with the tool assembly in an unapproximated position;

[0057] FIG. 22A is a cross-sectional view taken along section line 22A-22A of FIG. 21;

[0058] FIG. 22B is a cross-sectional view taken along section line 22B-22B of FIG. 21;

[0059] FIG. 23A is a cross-sectional view taken along section line 23A-23A of FIG. 21;

[0060] FIG. 23B is a cross-sectional view taken along section line 23B-23B of FIG. 21;

[0061] FIG. 24A is an enlarged view of the indicated area of detail shown in FIG. 22A;

[0062] FIG. 24B is an enlarged view of the indicated area of detail shown in FIG. 22B;

[0063] FIG. 25A is a cross-sectional view taken along section line 25A-25A of FIG. 21;

[0064] FIG. 25B is a cross-sectional view taken along section line 25B-25B of FIG. 21;

[0065] FIG. 26 is a top, perspective view of the tool assembly of the stapler reload shown in FIG. 21 with the tool assembly in the approximated position and the firing cams advanced into engagement with a proximal-most staple of the plurality of staples;

[0066] FIG. 27 is a side, cross-sectional view of the tool assembly of the stapler reload shown in FIG. 26;

[0067] FIG. 28 is an enlarged view of the indicated area of detail shown in FIG. 27;

[0068] FIG. 29 is a view of the area of detail shown in FIG. 28 with the firing cams advanced into engagement with a second proximal-most staple;

[0069] FIG. 30 is a view of the area of detail shown in FIG. 29 with the firing cams advanced into engagement with a third proximal-most staple;

[0070] FIG. 30A is a view of the area of detail shown in FIG. 30 with the firing cam advanced into engagement with the fourth proximal-most staple and the proximal-most staple disengaged from the cartridge body;

[0071] FIG. 31 is a perspective view of a staple of the tool assembly of the stapler reload shown in FIG. 26 after the staple has been deformed;

[0072] FIG. 32 is a cross-sectional view taken along section line 32-32 of FIG. 26;

[0073] FIG. 33 is a side, perspective view of the stapler reload shown in FIG. 1A in a non-articulated and unapproximated position with the proximal tube of the proximal body portion and the shaft tube of the shaft portion removed;

[0074] FIG. 34 is a top perspective view of the proximal body portion of the stapler reload with the proximal tube removed and the upper housing half section removed;

[0075] FIG. 35 is a top perspective view of the upper housing half section of the proximal body portion of the stapler reload;

[0076] FIG. 36 is a top, perspective view of the proximal body portion of the stapler reload shown in FIG. 35 with the proximal tube and the upper housing half section removed and the articulation member rotated; and

[0077] FIG. 37 is a top view of the tool assembly of the stapler reload, shown in FIG. 26 in an articulated position.

Detailed Description of Embodiments

[0078] Embodiments of the presently disclosed endoscopic surgical stapler including staples with staggered legs will now be described in detail with reference to the drawings wherein like reference numerals designate identical or corresponding elements in each of the several views. In this description, the term “proximal” is used generally to refer to the portion of the apparatus that is closer to a clinician, while the term “distal” is used generally to refer to the portion of the apparatus that is farther from the clinician. In addition, the term “endoscopic” procedure is used generally to refer to endoscopic, laparoscopic, arthroscopic, and any other surgical procedure performed through a small incision or a cannula inserted into a patient’s body. Finally, the term clinician is used generally to refer to medical personnel including doctors, nurses, and support personnel.

[0079] The presently disclosed surgical stapler includes a tool assembly which supports a series of staples which are supported and configured to be rotatably ejected from a staple cartridge into an anvil to suture tissue. The manner in which the staples are supported and ejected from within the staple cartridge facilitates the use of a small diameter tool assembly which includes staples capable of suturing thicker tissues than would normally be associated with tool assemblies with such a small diameter. In embodiments, the surgical stapler includes at least one firing cam having staggered cam members and the staples are configured with staggered legs. Each of the staple legs has a D-shaped configuration when deformed.

[0080] FIG. 1-2 illustrate the presently disclosed surgical stapler 10 which includes an actuating device 12 having a handle assembly 12a, a body portion 14 which extends distally from the handle portion 12, and a stapler reload 100 supported on a distal end of the body portion 14. The distal end of the body portion 14 is adapted to releasably engage a proximal end of the reload 100 such that actuation of the actuating device 12 effects operation of the reload 100. A suitable actuating device is disclosed in detail in U.S. Patent Nos. 5,865,361 (“361 patent”) and 7,143,924 (“924 patent”) which are incorporated herein in their entirety by reference. Although the presently disclosed actuating device is illustrated as a manually actuated handle assembly, it is envisioned that other known actuating devices including robotic devices, motorized devices, and/or electrically or mechanically driven devices can be used to actuate the reload 100.

[0081] In an alternate embodiment, the reload 100 can be fixedly attached to the distal end of the handle assembly 12 and only a cartridge assembly of a tool assembly can be removable and replaceable. Alternatively, a removable and replaceable reload can also have a removable and replaceable cartridge.

[0082] Referring also to FIGS. 3-3C, the reload 100 includes a proximal body portion 110, an elongated shaft portion 112 and a tool assembly 114. The proximal body portion 110 includes an inner housing 116 (FIG. 25A) defined by an upper housing half-section 116a and a lower housing half-section 116b. The housing half-sections 116a and 116b define channels which slidably receive a proximal drive member 118, a first articulation link 120 and a second articulation link 122. The housing half-sections 116a and 116b are received within a proximal body tube 125.

[0083] The first articulation link 120 is connected to the second articulation link 122 by an articulation member 123 which will be described in detail below. The proximal drive member 118 supports a drive coupler 124 that is adapted to engage a control rod (not shown) of the actuating device 12 (FIG. 1) to operate the tool assembly 114 of the reload 100. The proximal drive member 118 also supports a locking assembly 126 which includes a locking device 128 and a spring 130. Operation of the drive coupler 124 and the locking assembly 126 are described in the '361 patent which is incorporated herein by reference. As such, the drive coupler 124 and locking assembly 126 will not be described in further detail herein. A distal end of the proximal drive member 118 includes a T-shaped recess 118a. In addition, the distal ends of the first articulation link 120 and the second articulation link 122 include hook portions 120a and 122a, respectively (FIG. 3B). Each of these hook portions 120a and 122a and the T-shaped recess 118a are described in further detail below.

[0084] The elongated shaft portion 112 of the reload 100 includes an inner housing 134 (FIG. 25A) defined by upper and lower housing half-sections 134a and 134b which are received within a shaft portion tube 112a. A proximal end of the inner housing 134 of the elongated shaft portion 112 is received within the distal end of the inner housing 116 of the proximal body portion 110 and includes an annular recess 135. The annular recess 135 receives a protrusion 116c (FIG. 25A) formed within the inner housing 116 to axially secure the inner housing 116 of the proximal body portion 110 to the inner housing 134 of the shaft portion 112. The upper and lower housing half-sections 134a, 134b of the elongated shaft portion 112 define internal channels (not shown) which slidably receive a pair of distal drive members 136a, 136b, a pair of firing cams 138a, 138b, and a pair of cartridge channel members 140a, 140b. A proximal end of each of the cartridge channels 140a, 140b defines a cutout 142a, 142b, respectively. The cutouts 142a, 142b of the cartridge channels 140a, 140b receive one side of the hook portions 120a, 122a (FIG. 3B), respectively, of the first and second articulation links 120, 122 such that linear movement of the first and second articulation links 120, 122 effects linear movement of the cartridge channels 140a, 140b as described in further detail below.

[0085] A proximal end of each of the distal drive members 136a, 136b includes a hook portion 144a and defines a recess 144b. Similarly, the proximal end of the firing cams 138a, 138b includes a hook portion 146a and define a recess 146b. Each of the recesses 144b, 146b is defined by a distal wall 144c, 146c, respectively. The distal wall 146c defining each recess 146b of the firing cams 138a, 138b is positioned distally of the distal wall 144c defining each recess

144b of the distal drive members 136a, 136b. The proximal drive member 118 and the proximal end of the distal drive members 136a, 136b are connected by a drive member link 119. The drive member link 119 has a proximal end configured to be received in the T-shaped slot 118a of the proximal drive member 118. A distal end of the drive member link 119 includes a hook portion 119a and defines a recess 119b. The hook portion 119a is received within the recesses 144b, 146b of the distal drive members 136a, 136b and the firing cam 138a, 138b, respectively, such that the hook portions 144a, 146a of the distal drive members 136a, 136b and the firing cams 138a, 138b, respectively, are slidably received within the recess 119b of the drive member link 119. As such, movement of the proximal drive member 118 effects corresponding movement of the drive member link 119. As the drive member link 119 is moved distally, the hook portion 119a of the drive member link 119 moves within the recesses 144b and 146b of the distal drive members 136a, 136b and the firing cams 138a, 138b, respectively. When the hook member 119a engages the distal walls 144c, 146c defining the recesses 144b and 146b of the distal drive members 136a, 136b and the firing cams 138a, 138b, respectively, distal movement of the drive member link 119 will effect corresponding distal movement of the distal drive members 136a, 136b and the firing cams 138a, 138b, respectively. As discussed above, the distal wall 146c of the recesses 146c of the firing cams 138a, 138b are positioned distally of the distal walls 144c of the distal drive members 136a, 136b. As such, distal movement of the drive member link 119 will effect distal movement of the distal drive members 136a, 136b prior to effecting distal movement of the firing cams 138a, 138b as described in further detail below. It is envisioned that the proximal drive member 118 and the drive member link 119 can be formed as a unitary component. As best shown in FIG. 3C, the distal end of the distal drive members 136a and 136b are secured to a working member 150 such as by welding. Alternately, other securement techniques can be used to secure the distal end of the drive members 136a, 136b to the working member 150. In one embodiment, the working member 150 includes an upper beam 152, a lower beam 154 and a vertical strut 156 interconnecting the upper and lower beams 152, 154. A cutting edge 156a is formed on or supported on a distal end of the vertical strut 156. The vertical strut 156 is movably positioned between the cartridge channels 140a, 140b, the firing cams 138a, 138b and the legs 188 of the cartridge body 184 as described in further detail below. The working member 150 is positioned and configured to move through the tool assembly 114 when the distal drive members 136a, 136b are moved distally within the elongated shaft portion 112 to actuate the tool assembly 114.

[0086] Referring again to FIGS. 3 and 3A, a pivot member 157 is secured to a distal end of the shaft housing half-sections 134a, 134b by upper and lower connecting members 160a, 160b. Each connecting member 160a, 160b includes a distal end which defines an opening 162 and a proximal end 164 which has a stepped configuration. The stepped configuration of the proximal end 164 of each connecting member 160a, 160b is received within a cutout 166 formed in the distal end of each of the upper and lower shaft housing half-sections 134a, 134b to axially fix the upper and lower connecting members 160a, 160b to the upper and lower shaft housing half-sections 134a, 134b, respectively. The openings 162 of each of the upper and lower connecting members 160a, 160b receive a respective pivot pin 170 (only one shown, FIG. 3A) formed on the upper and lower surfaces of the pivot member 157 to pivotally secure the pivot member 157 to the shaft housing half-sections 134a, 134b. The pivot member 157 also includes two transversely extending posts 172. Each post 172 is received in an opening 210a (FIG. 3C) formed in one of the cartridge channels 140a, 140b to secure the pivot member 156 between the cartridge channels 140a, 140b.

[0087] Referring to FIGS. 3-8, the tool assembly 114 includes a cartridge assembly 180 and an anvil 182. The cartridge assembly 180 (FIG. 6) includes a cartridge body 184 and a plurality of staples 185. The cartridge body 184 includes a tapered distal end 186 and first and second spaced legs 188. The tapered distal end 186 of the cartridge body 184 functions as a tissue guide and includes three proximally extending fingers 190. One of the fingers 190 is positioned on each side of each of the spaced legs 188 with one finger 190 being positioned between the spaced legs 188. Each of the fingers 190 defines a recess 192 with an adjacent leg 188. The recesses 192 receive the distal ends 191 (FIG. 3C) of the cartridge channels 140a, 140b to secure the cartridge body 184 to the distal end of the cartridge channels 140a, 140b.

[0088] Each of the first and second spaced legs 188 of the cartridge body 184 includes a series of rectangular cutouts 196 and notches 198 which are spaced along each leg 188 of the cartridge body 184. The rectangular cutouts 196 and spaced notches 198 are configured and dimensioned to releasably engage the staples 185 as described in detail below. A base 198a of each notch 198 has a circular configuration to facilitate rotation of the staples 185 within a respective notch 198 as the staples are formed as described in further detail below. A series of dimples 199 are spaced along inner and outer walls of the legs 188 of the cartridge body 184. The dimples 199 are positioned to engage a proximal leg portion 202a of each staple 185 to secure the staples 185 to the cartridge body 184 as described in detail below.

[0089] Referring to FIGS. 5A-5C, each of the staples 185 includes a pair of staple legs 200a, 200b interconnected by an intermediate portion 201. Each of the staple legs 200a, 200b has tapered tip 200c and a curved, substantially V-shaped body 202. The intermediate portion 201 is S-shaped and has a first end connected to the staple leg 200a and a second end connected to the staple leg 200b.

[0090] The V-shaped body 202 of each of the staple legs 200a, 200b includes a proximal leg portion 202a and a distal leg portion 202b. One end of the proximal leg portion 202a is connected to one end of the intermediate portion 201 and the other end of the proximal leg portion 202a is connected to one end of the distal leg portion 202b. The other end of the distal leg portion 202b defines a tapered tip 202c. The distal leg portion 202b is curved upwardly and rearwardly towards the intermediate portion 201.

[0091] Referring again to FIGS. 5A-8, each rectangular cutout 196 of the cartridge body 184 is configured to receive a distal U-shaped portion 204a of the intermediate portion 201 of the staple 185 to secure the staples 185 to a respective leg 188 of the cartridge body 184. In addition, each notch 198 is configured to receive a proximal portion 204b of the intermediate portion 201 of the staple 185 in snap-fit engagement to rotatably secure the staples 185 to respective legs 188 of the cartridge body 184. As discussed above, engagement between the dimples 199 and the proximal leg portion 202a of each staple 185 assists in releasably securing the staples to the cartridge body 184. With the staples 185 secured to the legs 188 of the cartridge body 184, the proximal portion 204b of the intermediate portion 201 of each staple 185 extends transversely across a respective leg 188 of the cartridge body 184 such that the legs 200a, 200b of each staple 185 are positioned on opposite sides of a respective leg 188 of the cartridge body 184 on which the staple 185 is supported.

[0092] As best shown in FIG. 8, the legs 200a and 200b of each staple 185 are staggered along a longitudinal axis of the cartridge body 184 by the distance defined by the width "X" (FIG. 5A) of the intermediate body portion 201. In one embodiment, the outer leg 200a of each staple 185 is positioned proximally of the inner leg 200b.

[0093] Referring to FIGS. 3-3C and 9-13, each of the cartridge channels 140a and 140b has a substantially similar configuration. As such, only cartridge channel 140b will be described in detail herein. Cartridge channel 140b (FIG. 3) includes a resilient body that extends from the

proximal body portion 110 (FIG. 1) of the reload 100 (FIG. 1) to the tool assembly 114. A distal end of each cartridge channel 140b includes a U-shaped member 208 that receives a leg 188 of the cartridge body 184 and defines two openings (Fig. 13) including a proximal opening 210a and a distal opening 210b. The proximal opening 210a receives the post 172 (FIG. 3A) of the pivot member 157 to secure the cartridge channel 140b of the cartridge assembly 180 to the pivot member 157. The distal opening 210b receives a pin 211 (FIG. 3C) that extends through the opening 182a in a proximal end of the anvil 182, through the opening 210b in the cartridge channel 140b, and through an opening 214 (FIG. 6) in the proximal end of each of legs 188 of the cartridge body 184 to secure the proximal end of the legs 188 of cartridge body 184 to the respective cartridge channels 140a, 140b. A distal end 191 of each U-shaped member 208 is received in adjacent recesses 192 (FIG. 6) formed on opposite sides of each leg 188 of the cartridge body 184. The distal end 191 is defined by a pair of cutouts 191a (FIG. 12) and distally extending fingers 191b (FIG. 12). A bottom wall 193 (FIG. 13) of each cartridge channel 140b is w-shaped and defines channels that guide the rotational movement of the staples 185 within the cartridge channel 140b as the staples 185 are ejected from the cartridge assembly 180.

[0094] Referring to FIGS. 3-3C and 14-18, the distal end 220 of each firing cam 138a and 138b defines a cam member 222. Each cam member 222 has a curved shape. In certain embodiments, the cam member 222 includes a first portion for moving the staple 185 into engagement with staple forming depressions 182b of the anvil 182 and at least one other portion for forming the staple 185 into a closed configuration. In the embodiment shown, the cam member 222 has a portion for partially forming the staple 185, and a portion for deforming the staple 185 into its final configuration as described in further detail below.

[0095] Each cam member 222 of the first and second firing cams 138a, 138b has first and second cam surfaces 222a, 222b that are staggered along the longitudinal axis of the firing cam 138. Each cam member 222 is U-shaped and defines a channel 224 that receives a respective one of legs 188 (FIG. 3C) of the cartridge body 184. The cam members 222 are slidable about the respective legs 188 of the cartridge body 184 to move the first and second cam surfaces 222a, 222b into engagement with the legs 200a, 200b of the staples 185 supported on the respective legs 188 of the cartridge body 184.

[0096] Each of the cam surfaces 222a, 222b is curved and defines a first curved surface 226 and a second curved surface 228 which are interconnected by a plateau 230. The cam surfaces 222a, 222b have a height that increases from a distal end of each of the cam surfaces 222a, 222b towards a proximal end of each of the cam surfaces 222a, 222b. The first curved surface 226 of the cam surfaces 222a, 222b is configured to initiate deformation of a leg 200a, 200b of a staple 185 and the second curved surface 228 is configured to complete deformation of the leg 200a, 200b of a staple 185 and to disengage the leg 200a, 200b from the circular base 198a of a respective notch 198 of the cartridge body 184 as described in further detail below.

[0097] Referring also to FIGS. 19 and 20, when the cartridge channels 140a and 140b are positioned about the legs 188 of the cartridge body 184 and secured to the cartridge body 184, a space "s" (Fig. 32) is defined between sidewalls of the legs 188 of the cartridge body 184 and inner walls of the cartridge channels 140a, 140b. The staple legs 200a, 200b are positioned in the space "s". In addition, the cam surfaces 222a, 222b of each of the firing cams 138a and 138b are slidably supported in the spaces "s". When the firing cams 138a, 138b are advanced distally from a retracted position to an advanced position, the cam surfaces 222a, 222b are moved between the legs 188 and the cartridge channels 140a, 140b into sequential contact with the legs 200a, 200b of the staples 185 (FIG. 18) to urge the staples 185 from the cartridge body 184 into the staple forming depressions 182b (FIG. 22A) of the anvil 182 as described in further detail below.

[0098] Referring to FIGS. 3C and 21-25B, the anvil 182 defines an elongated slot 252 and an elongated recess 254. The vertical strut 156 (FIG. 25B) of the working member 150 passes through the elongated slot 252 such that the upper beam 152 is slidably positioned in the elongated recess 254 of the anvil 182. A proximal end of the anvil 182 defines a tapered cam surface 256 (FIG. 22A) which is positioned in engagement with a distal end of the upper beam 152 of the working member 150 when the anvil 182 is in the open position as shown in FIG. 22A. The lower beam 154 is positioned to move along the bottom surface of the cartridge channels 140a, 140b. As shown, the anvil 182 is biased to an open position by a biasing member, e.g., one or more leaf springs 400 (FIG. 3C). In embodiments, the leaf springs 400 have a U-shaped proximal end 402 compressed between a proximal end of the cartridge body 184 and a distal face of the pivot member 157. A distal end of the leaf springs 400 engages an under surface of the anvil 182 to urge the anvil 182 to the open position.

[0099] Referring briefly again to FIG. 3, the reload 100 includes a locking member 300 which is rotatably supported about a proximal end of the inner housing 116 of the proximal body portion 110. The locking member 300 is movable from a first position in which the locking member 300 blocks distal movement of the proximal drive member 118 to a second position in which the locking member 300 moves to a position to allow distal movement of the proximal drive member 118. U.S. Patent No. 7,143,924 describes the locking member 300 and its method of operation in detail and is incorporated herein by reference in its entirety.

[0100] Referring again to FIGS. 3 and 21-25B, when the proximal drive member 118 (FIG. 3) is in a retracted position, the drive member link 119 and, thus, the distal drive members 136a, 136b and the firing cam 138a, 138b are also in a retracted position (FIG. 25B). In the retracted position, the hook portion 119a is engaged with the hook portions 144a, 146a of the distal drive members 136a, 136b and the firing cams 138a, 138b, respectively, and is positioned within the proximal end of the recesses 144b, 146b of the distal drive members 136a, 136b and the firing cams 138a, 138b. In addition, the distal end of the upper beam 152 of the working member 150 is positioned proximally of the tapered cam surface 256 (FIG. 22A) of the anvil 182 to allow the biasing members 400 to position or move the anvil 182 to the open position spaced from the cartridge body 184 (FIG. 22A). In the retracted position of the firing cams 138a, 138b, the cam surfaces 222a, 222b (FIG. 20) of each of the firing cams 138a, 138b is positioned proximally of the a respective leg 200a, 200b of the proximal-most staple 185 (FIG. 24A) such that a proximal end 259 (FIG. 18) of cam surface 222b of each firing cam 138a, 138b is in abutment with a shoulder 260 (FIG. 6) of a respective leg 188 of the cartridge body 184. Referring to FIG. 26, when the proximal drive member 118 is advanced via operation of the actuating device 12 (FIG. 1), the hook portion 119a of the drive member link 119 translates through the recesses 144b, 146b of the distal drive members 136a, 136b and of the firing cams 138a, 138b. The recesses 146b of the firing cams 138a, 138b extend distally of the recesses 144b of the distal drive members 136a, 136b. When the hook member 119a of the drive member link 119 engages a wall 144c, 146c defining a distal end of the recesses 144b and 146b of the distal drive members 136a, 136b and the firing cams 138a, 138b, respectively, distal movement of the drive member link 119 will effect corresponding distal movement of the distal drive members 136c, 136b and the firing cams 138a, 138b. As discussed above, the wall 146c defining the distal end of each of the recesses 146b is positioned distally of the wall 144c defining the distal end of each of the recesses 144b of the distal drive members 136a, 136b. As such, distal movement of the drive

member link 119 will cause movement of the distal drive members 136a, 136b before causing distal movement of the firing cams 138a, 138b.

[0101] When the distal drive members 136a, 136b are advanced via the drive member link 119, the working member 150 is advanced in relation to the anvil 182. As the working member 150 is advanced, the upper beam 152 of the working member 150 (FIG. 27) is moved over the tapered cam surface 256 (FIG. 27) of the anvil 182 to pivot the anvil 182 to an approximated position (FIG. 26). In the approximated position, the distal end of the cam surfaces 222a, 222b of each of the firing cams 138a, 138b are positioned immediately proximal of or in contact with the proximal leg portion 202a of the proximal-most staple of the plurality of staples 185.

[0102] Referring to FIGS. 27-33, continued advancement of the proximal drive member 118 (FIG. 25), will subsequently move the cam surfaces 222a, 222b (only 222b is shown in Figs. 29-33) of each of the firing cams 138a, 138b sequentially into contact with the staples 185. More particularly, when the firing cams 138a, 138b are advanced about legs 188 of cartridge body 184, the cam surfaces 222a, 222b sequentially engage the proximal leg portions 202a of the staples 185 to rotate or pivot the staples 185 about the proximal portion 204b of the intermediate portion 201 within the notches 198. As the first curved cam surface 226 of cam surfaces 222a, 222b moves under the proximal leg portion 202a of each staple 185, each staple 185 is pivoted or rotated upwardly to direct the tapered tip 202c of the staple 185 into a staple forming depression 182b of the anvil 182 to initiate deformation of the staple 186 FIG. 28).

[0103] After the first curved cam surface 226 of the cam surfaces 222a, 222b moves past the proximal leg portion 202a of the staple 185, the plateau 230 of the cam surfaces 222a, 222b moves under the proximal leg portion 202a of the staple 185. The height of the plateau 230 is less than the height of the rectangular cutouts 196 and the base 198a of the notches 198. As such, at this stage of advancement of the firing cams 138a, 138b, the proximal-most staples 185 remain engaged with the legs 188 of the cartridge body 184.

[0104] Upon continued advancement of the firing cams 138a, 138b, the second curved surface 228 of each of the cam surfaces 222a, 222b moves under the staples 185. Engagement of the second curved surface 228 of the cam surfaces 222a, 222b fully deforms the staple 185 and disengages or separates each staple 185 from the notches 198 of the legs 188 of the cartridge body 184. In that respect, the height at the proximal end of the second curved surface 228 of

the cam surfaces 222a, 222b is greater than the height of the cutouts 196 and the base 198a of the notches 198. As discussed above, the staple legs 200a and 200b of each staple 185 and the cam surfaces 222a and 222b of each of the firing cams 138a and 138b are staggered or offset axially. In embodiments, the degree of offset of the staple legs 200a and 200b is equal to the degree of offset of the cam surfaces 222a and 222b such that the cam surfaces 222a engage the legs 200a of a staple 185 at the same time that the cam surfaces 222b engage the legs 200b of the staple 185. As shown in FIGS. 30 and 31, the legs 200a, 200b of the fully formed staple 185 have substantially D-shape configurations and are axially offset from each other.

[0105] Referring to FIGS. 3-3C and 33-37, the tool assembly 114 can be articulated by movement of the cartridge channels 140a, 140b in opposite directions in relation to each other. As discussed above, the cartridge channels 140a, 140b extend from the proximal body portion 110 through the elongated shaft portion 112 to the tool assembly 114. A distal end of each of the cartridge channels 140a, 140b is connected to the pivot member 157 by respective posts 172 (Fig. 3A) that extend through the proximal openings 210a of the cartridge channels 140a, 140b. The proximal ends of the cartridge channels 140a, 140b include cutouts 142a, 142b (FIG. 3B), respectively, that receive one side of hook portions 120a, 122a of the articulation rods 120, 122, respectively, to connect the articulation rods 120, 122 to the cartridge channels 140a, 140b. The first and second articulation links 120, 122 are slidably supported between the housing halves 116a, 116b of the proximal body portion 110. The first articulation link 120 has a distal end connected to the cartridge channel 140a and a proximal end connected to an articulation assembly 350 (FIG. 1) of the actuating device 12 (FIG. 1).

[0106] The articulation member 123 includes a C-shaped body 302 having spaced fingers 304, 306 and a central opening 308 (Fig. 34). The fingers 304, 306 are received in cutouts 310 formed in the distal end of first and second articulation links 120 and 122. The central opening 308 receives a housing post 312 (FIG. 35) formed on housing half 116b of the central body portion 110 (FIG. 1) such that movement of the first articulation link 120 in one direction as indicated by arrow "A" in FIG. 36 causes the articulation member 123 to pivot about the housing post 312 to cause movement of the second articulation link 122 in a second direction as indicated by arrow "B" in FIG. 37.

[0107] In use, when the first articulation link 120 is moved by the articulation assembly 350 in direction A, the cartridge channel 140a, which is axially fixed to the first articulation link 120 by

placement of hook portion 120a in cutout 142a (Fig. 3B), is also moved in direction A. Movement of the first articulation link 120 in direction A effects pivotal movement of the articulation member 123 which causes movement of the second articulation link 122 in the direction of arrow B. Movement of the second articulation link 122 in direction of arrow B causes movement of cartridge channel 140b in the direction of arrow B.

[0108] As discussed above, the distal ends of cartridge channels 140a and 140b are connected to opposite sides of the pivot member 157 by posts 172. As the cartridge channels 140a, 140b are moved in opposite directions, the pivot member 157 is pivoted about the pivot pin 170 to pivot the tool assembly 114 in relation to shaft portion 112 such that the longitudinal axis of the tool assembly 114 moves from a position aligned with the longitudinal axis of the shaft portion 112 (FIG. 33) to a position at an angle to the longitudinal axis of the shaft portion 112. It is noted that the cartridge channels 140a, 140b, the firing cams 138a, 138b and the distal drive members 136a, 136b are all formed of a resilient material such as spring steel to facilitate movement about the axis of articulation, i.e., the axis of the pivot pin 170, to an articulated position.

[0109] Persons skilled in the art will understand that the devices and methods specifically described herein and illustrated in the accompanying drawings are non-limiting exemplary embodiments. It is envisioned that the elements and features illustrated or described in connection with one exemplary embodiment may be combined with the elements and features of another without departing from the scope of the present disclosure. As well, one skilled in the art will appreciate further features and advantages of the disclosure based on the above-described embodiments. Accordingly, the disclosure is not to be limited by what has been particularly shown and described, except as indicated by the appended claims.

CLAIMS

1. A surgical stapler comprising:
 - a shaft portion;
 - a tool assembly supported on a distal end of the shaft portion, the tool assembly including an anvil and a cartridge assembly, the cartridge assembly including a cartridge body having at least one leg defining a plurality of notches, and a plurality of staples, each of the plurality of staples having an intermediate portion interconnecting first and second staple legs wherein the intermediate portion of each of the plurality of staples is rotatably supported within a respective one of the plurality of notches, has a first end connected to the first leg and a second end connected to the second leg, wherein the first end of the intermediate portion is positioned distally of the second end of the intermediate portion; and
 - at least one firing cam including a distal end defining a cam member having first and second cam surfaces, the first cam surface positioned distally of the second cam surface, the cam member being movable within the tool assembly to move the first and second cam surfaces into sequential engagement with the first and second staple legs, respectively, of each of the plurality of staples, wherein engagement between the cam member and the first and second staple legs of each of the plurality of staples effects rotational movement of each of the plurality of staples about an axis defined by the intermediate portion that is transverse to the longitudinal axis within the respective one of the plurality of notches to fire each of the plurality of staples from the cartridge body.
2. The surgical stapler according to claim 1, wherein each notch of the plurality of notches is configured to rotatably support one of the staples of the plurality of staples.
3. The surgical stapler according to claim 1, wherein the at least one leg of the cartridge body defines a plurality of cutouts, each of the plurality of cutouts being spaced from adjacent notches of the plurality of notches and being configured to receive a first portion of the intermediate portion of one of the staples of the plurality of staples.
4. The surgical stapler according to claim 1, wherein the intermediate portion of each of the staples is S-shaped and includes a distal U-shaped portion that is configured to be received in a respective one of the cutouts of the plurality of cutouts on the at least one leg of the cartridge body.

5. The surgical stapler according to claim 1, wherein each of the notches of the plurality of notches is configured to rotatably receive a proximal portion of the intermediate portion of a respective one of the staples of the plurality of staples.
6. The surgical stapler according to claim 1, wherein the first and second staple legs of each of the staples of the plurality of staples has a curved configuration, wherein each of the first and second staple legs defines a D-shape when formed against the anvil.
7. The surgical stapler according to claim 5, wherein each notch of the plurality of notches includes a cylindrical slot that is configured to receive the proximal portion of the intermediate portion of a respective one of the staples of the plurality of staples in a snap-fit manner.
8. The surgical stapler according to claim 1, wherein the at least one leg of the cartridge body includes two spaced legs, the plurality of notches being spaced axially along each of the two spaced legs, and each of the plurality of notches rotatably supporting one of the staples of the plurality of staples.
9. The surgical stapler according to claim 8, further including first and second cartridge channels, each of the first and second cartridge channels having a distal end defining a U-shaped member, each of the two spaced legs of the cartridge body being secured within a respective one of the U-shaped members.
10. The surgical stapler according to claim 9, wherein the at least one firing cam includes first and second firing cams, each of the cam members of the first and second firing cams having a U-shape and being positioned about one of the two spaced legs of the cartridge body and within the U-shaped member of one of the first and second cartridge channels.
11. The surgical stapler according to claim 10, further including a pivot member pivotably secured to the distal end of the shaft portion and fixedly secured to each of the first and second cartridge channels.
12. The surgical stapler according to claim 11, further including a first articulation link having a distal end secured to a proximal end of the first cartridge channel and a second articulation link having a distal end secured to a proximal end of the second cartridge channel, the first and second articulation links being axially movable to effect axial movement of the first

and second cartridge channels in relation to each other to pivot the pivot member in relation to the shaft portion.

13. The surgical stapler according to claim 12, further including a pivotable articulation member interconnecting the first articulation link to the second articulation link such that movement of the first articulation link in one direction effects movement of the second articulation link in an opposite direction.

14. The surgical stapler according to claim 1, wherein each of the first and second staple legs of each of the staples has a tapered tip.

15. The surgical stapler according to claim 1, wherein each of the at least one leg of the cartridge body includes a plurality of dimples, each of the plurality of dimples being positioned to engage one of the first and second legs of one of the staples of the plurality of staples to stabilize the staple on the cartridge body.

Covidien LP

Patent Attorneys for the Applicant/Nominated Person

SPRUSON & FERGUSON

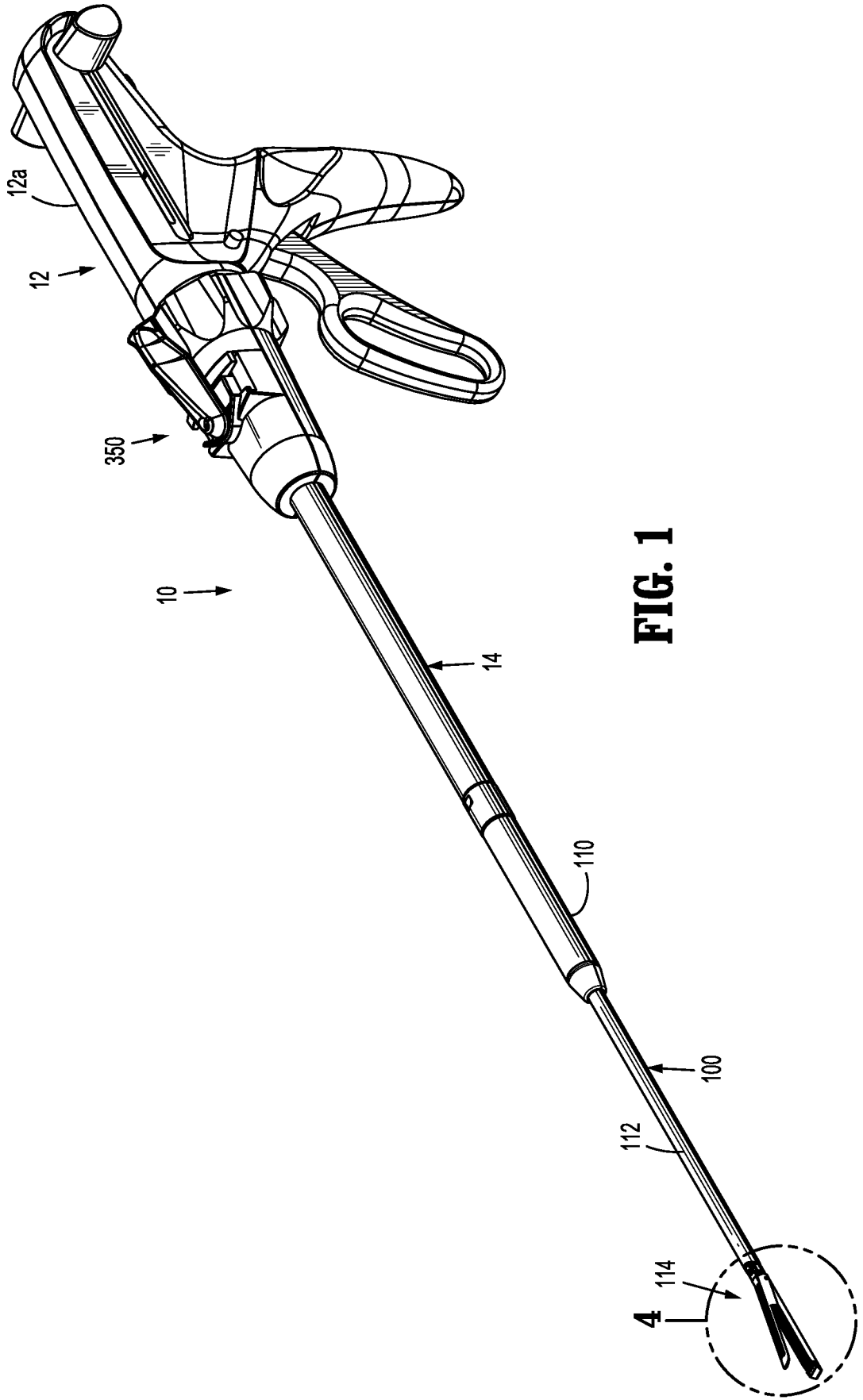

FIG. 1

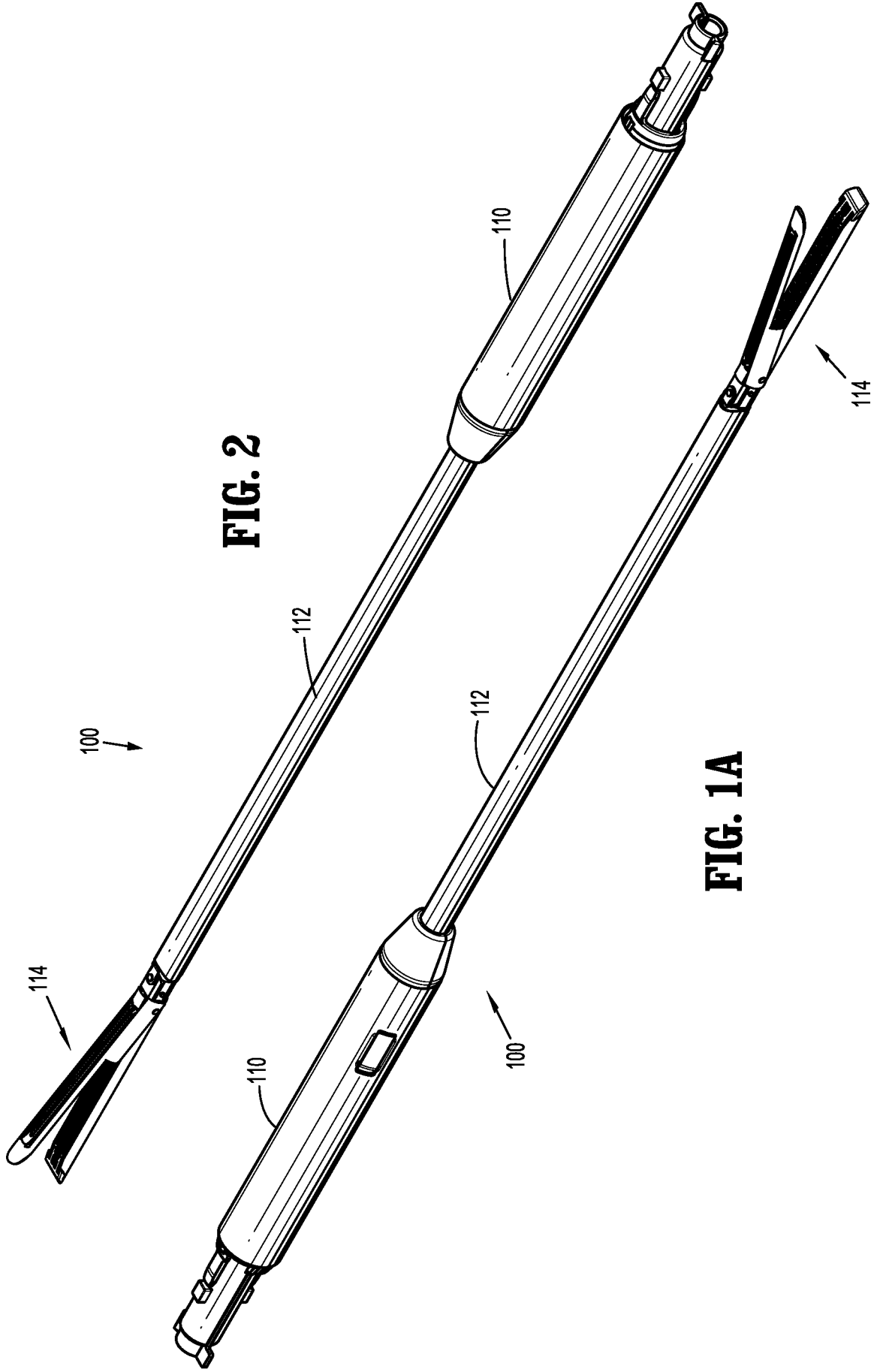

FIG. 2

FIG. 1A

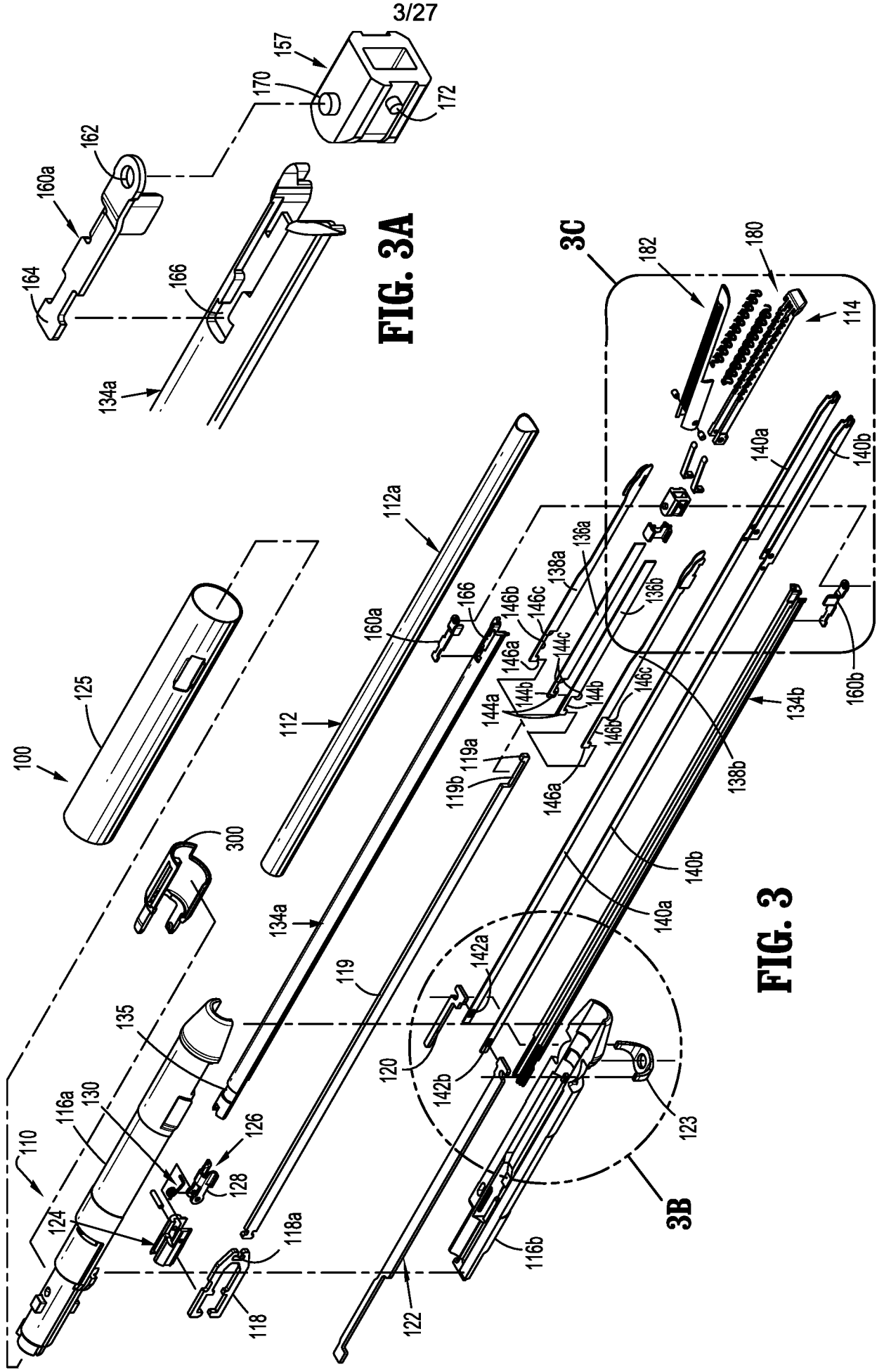

FIG. 3A

FIG. 3

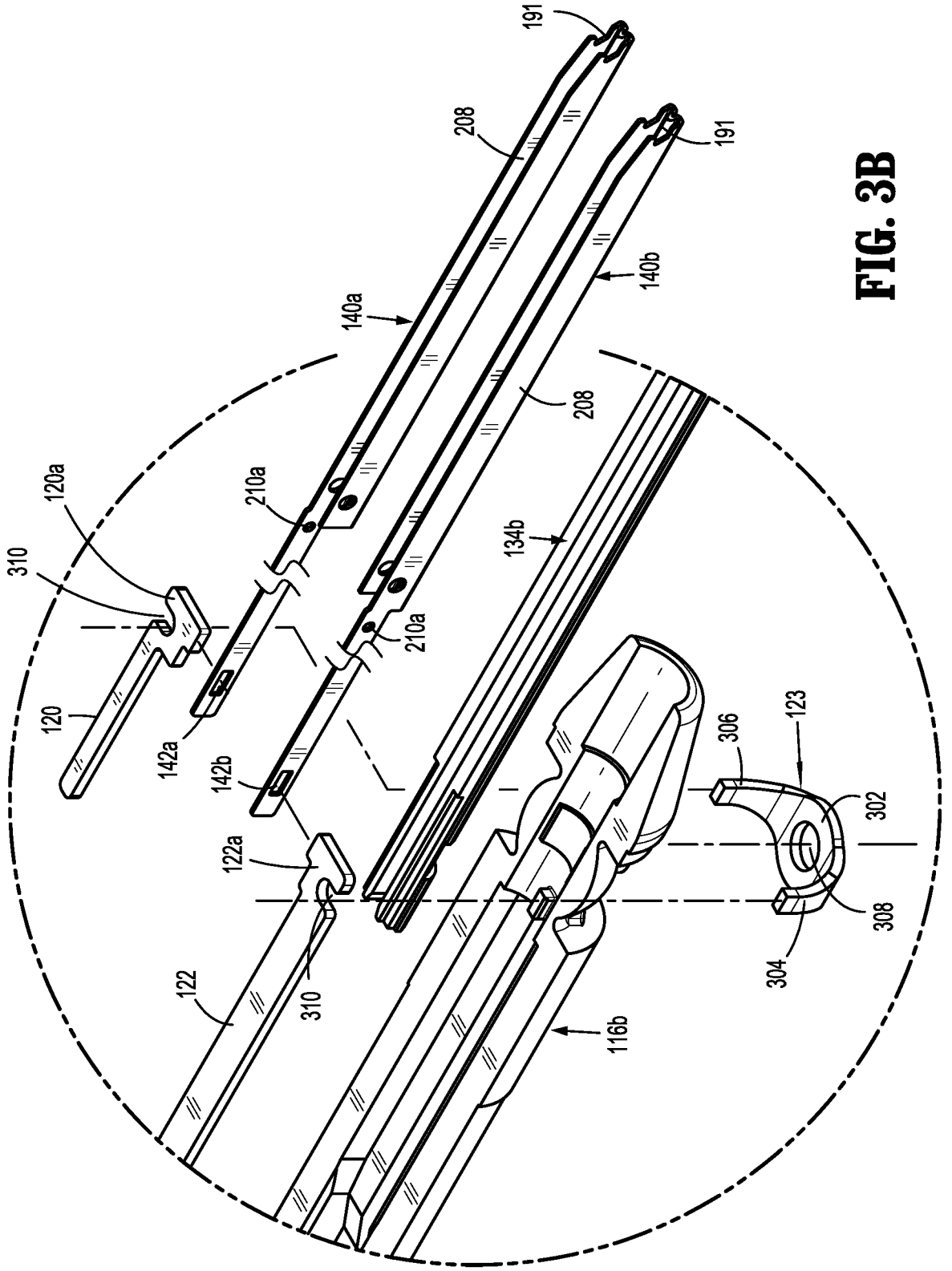

FIG. 3B

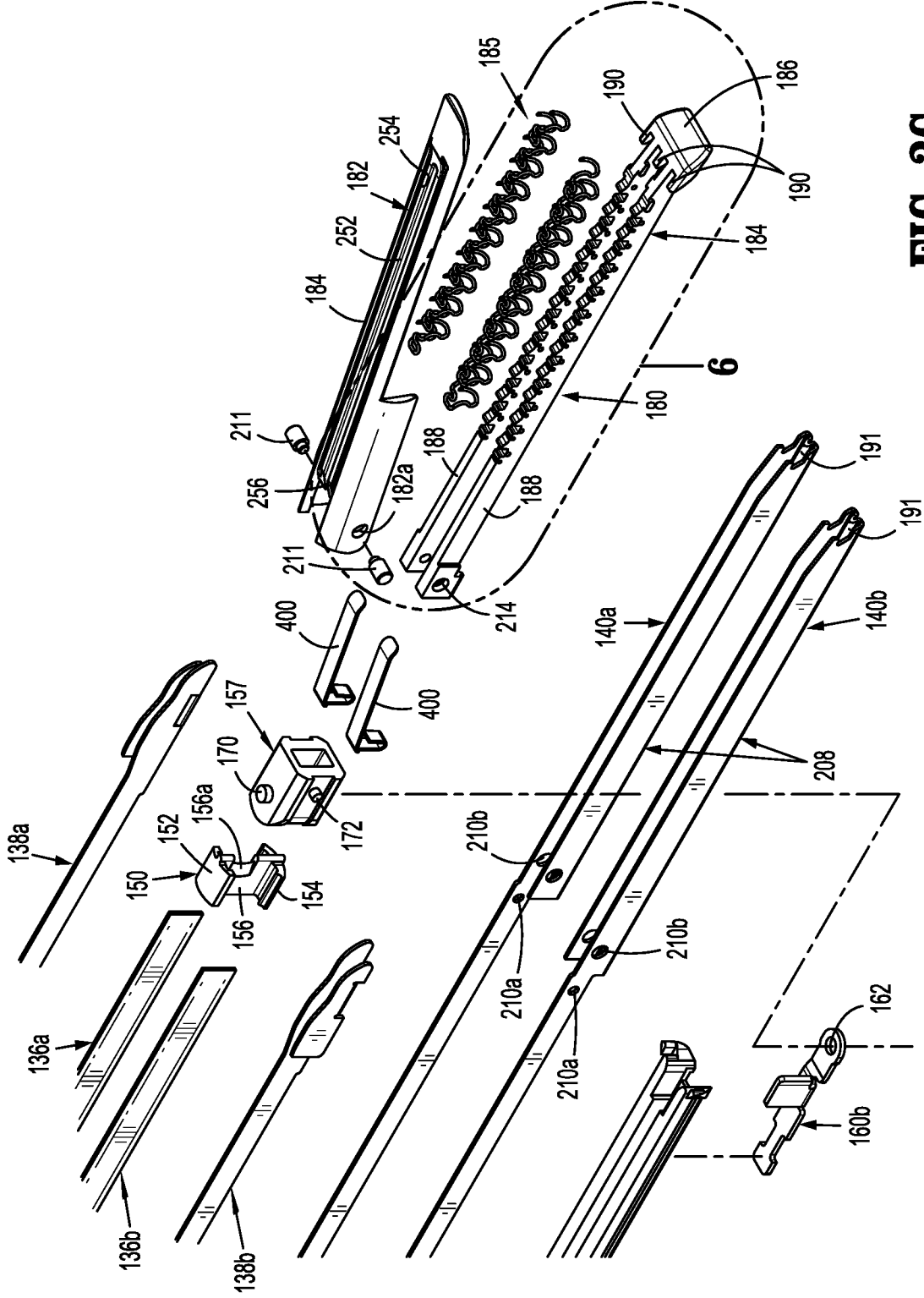

FIG. 3C

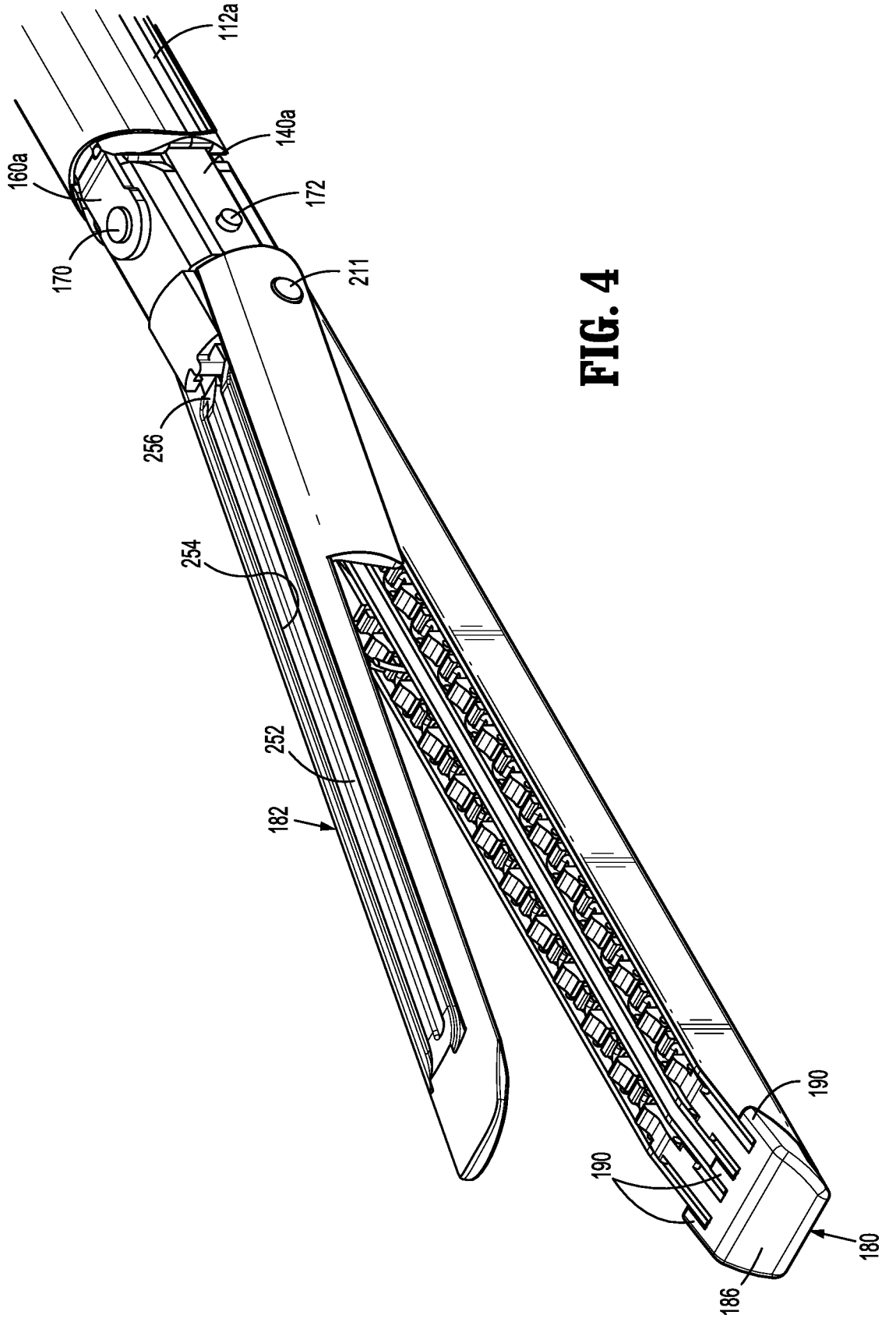

FIG. 4

7/27

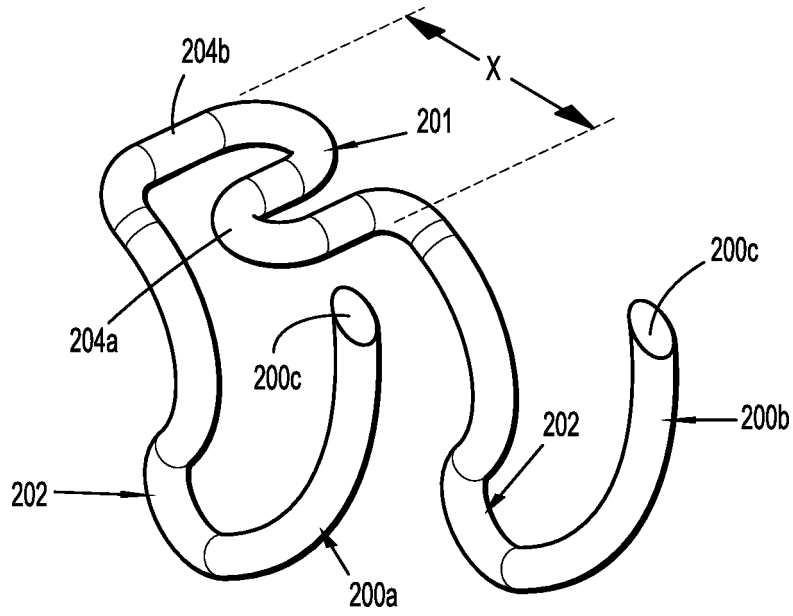

FIG. 5A

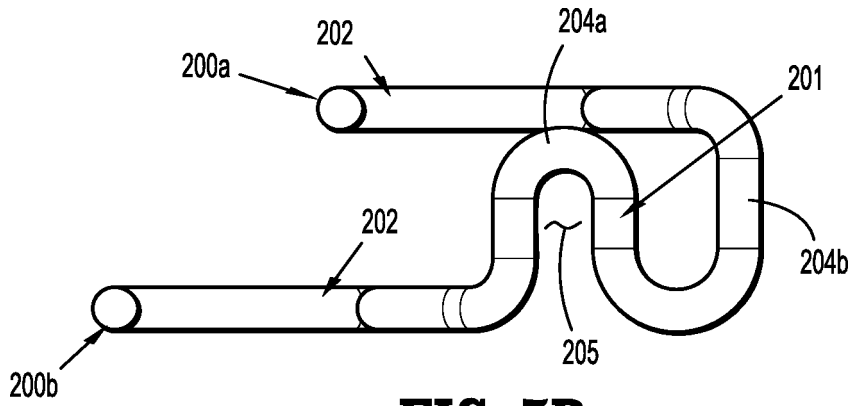

FIG. 5B

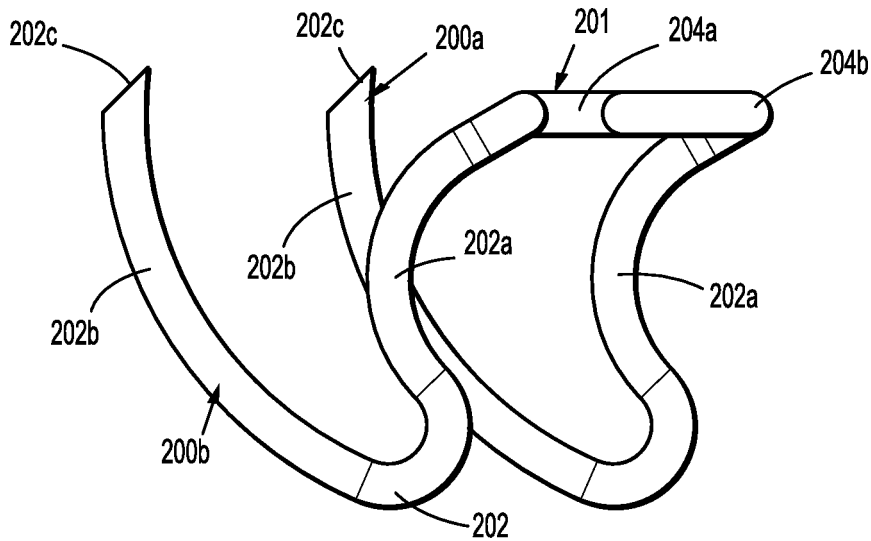

FIG. 5C

8/27

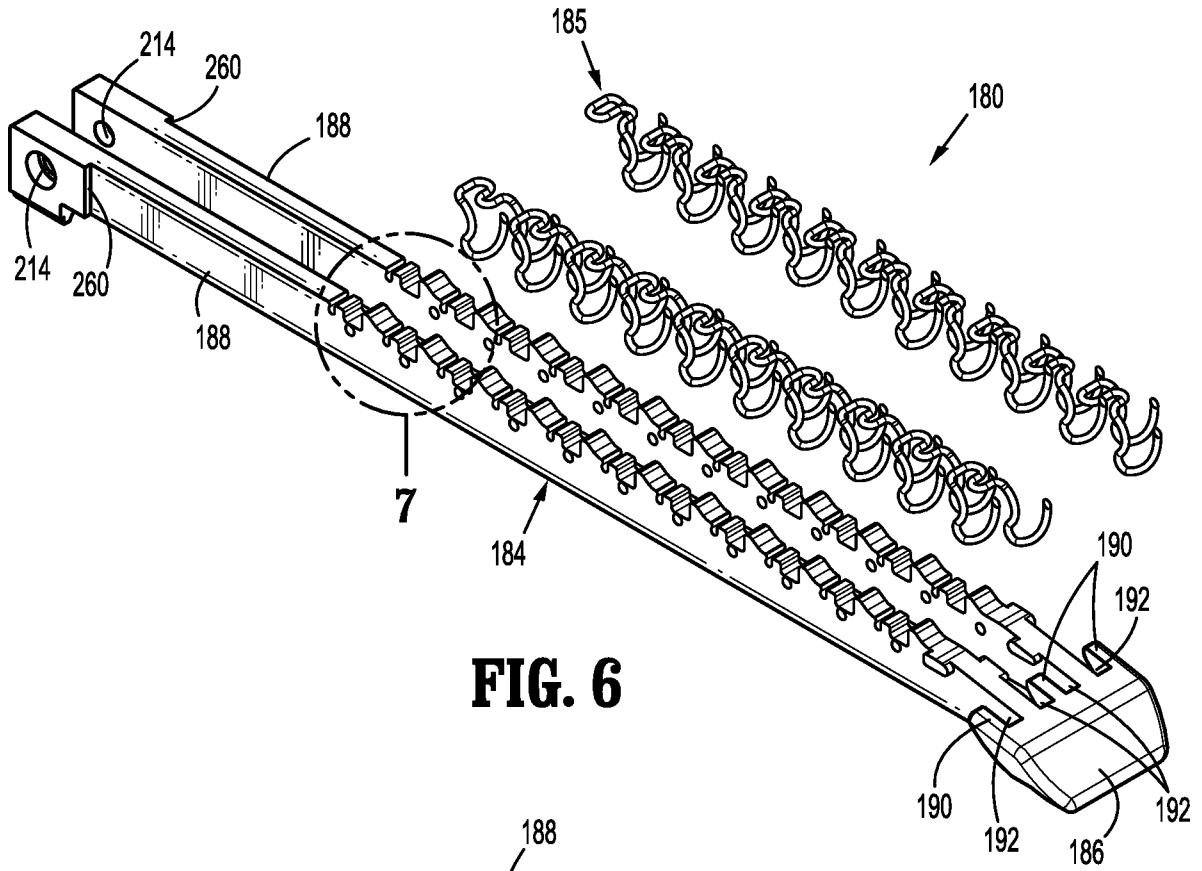

FIG. 6

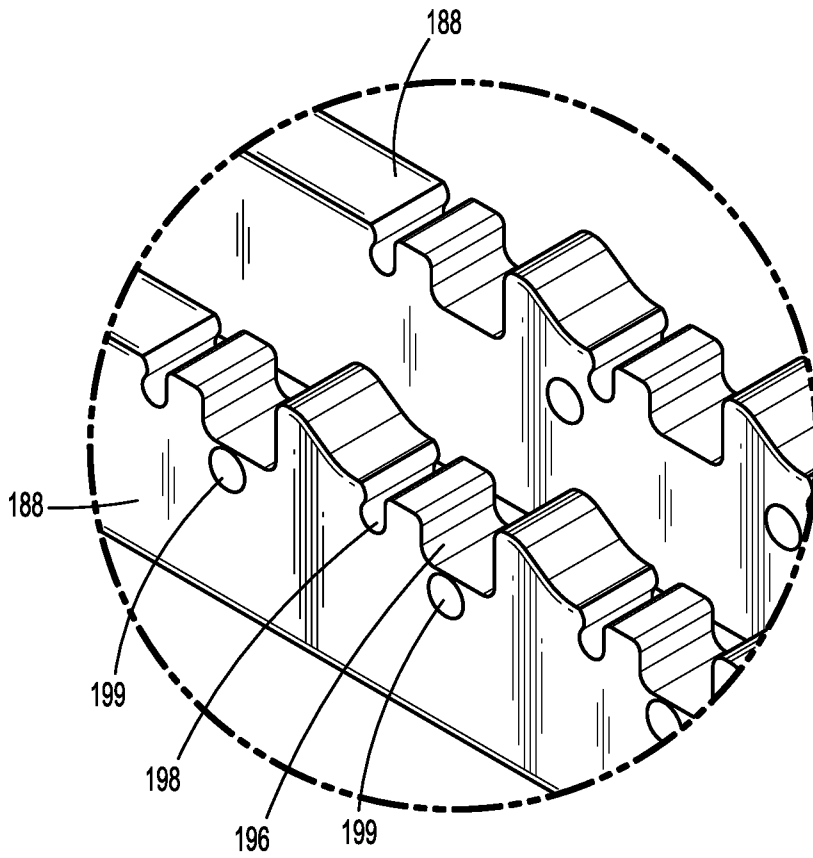
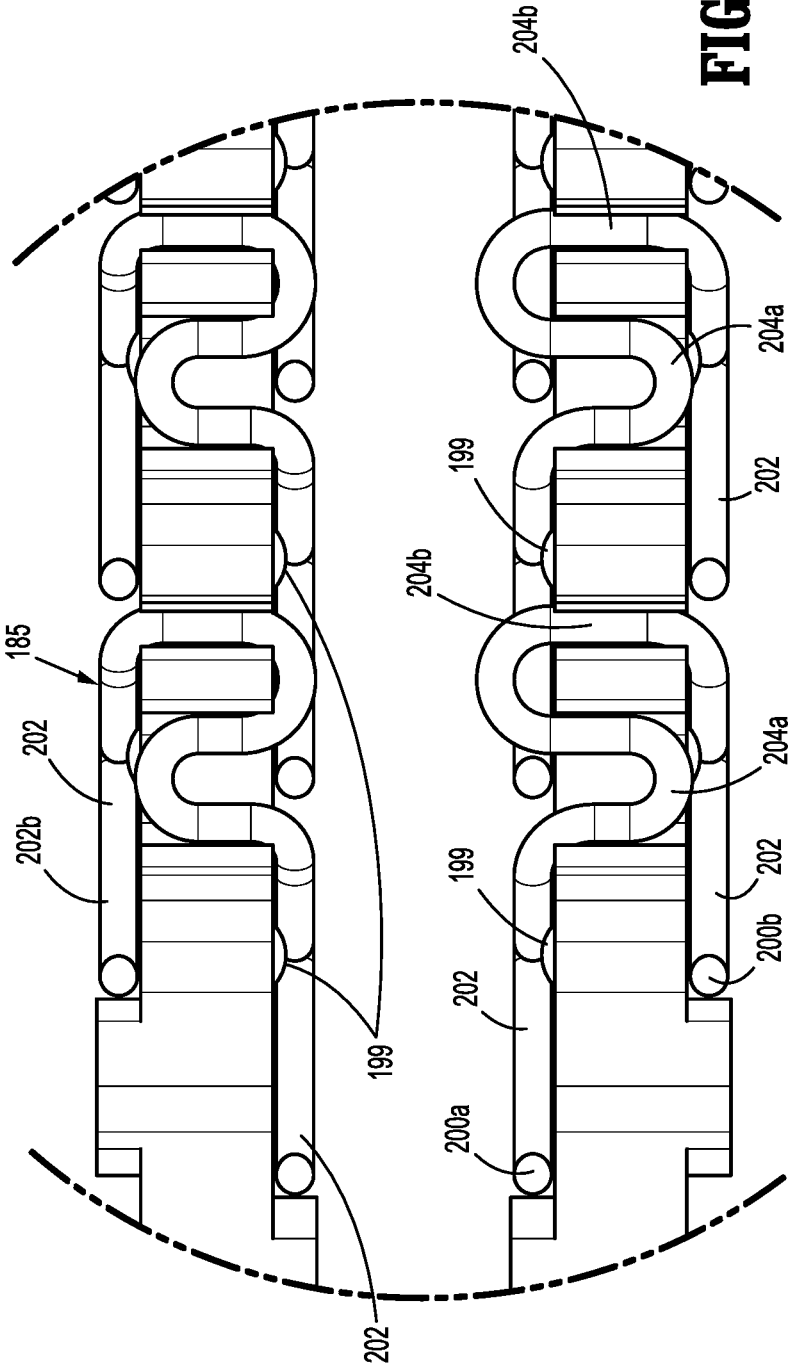
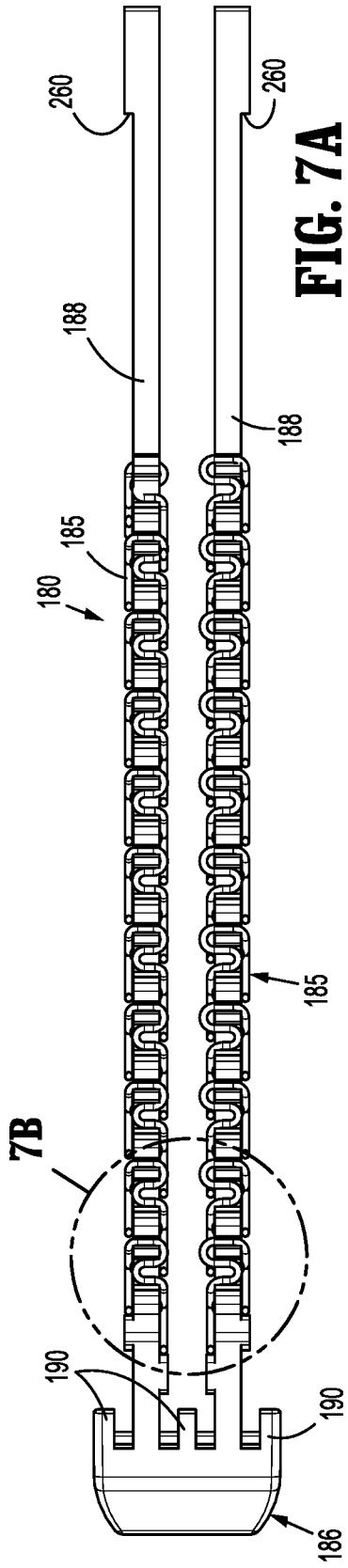
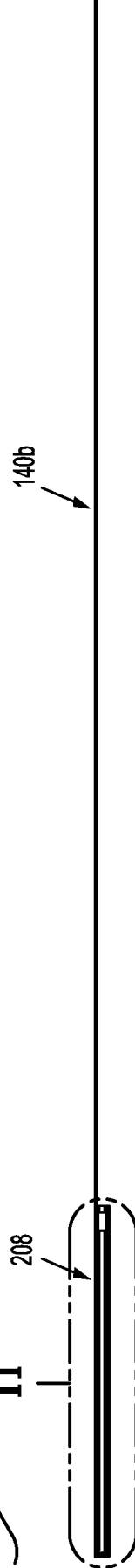
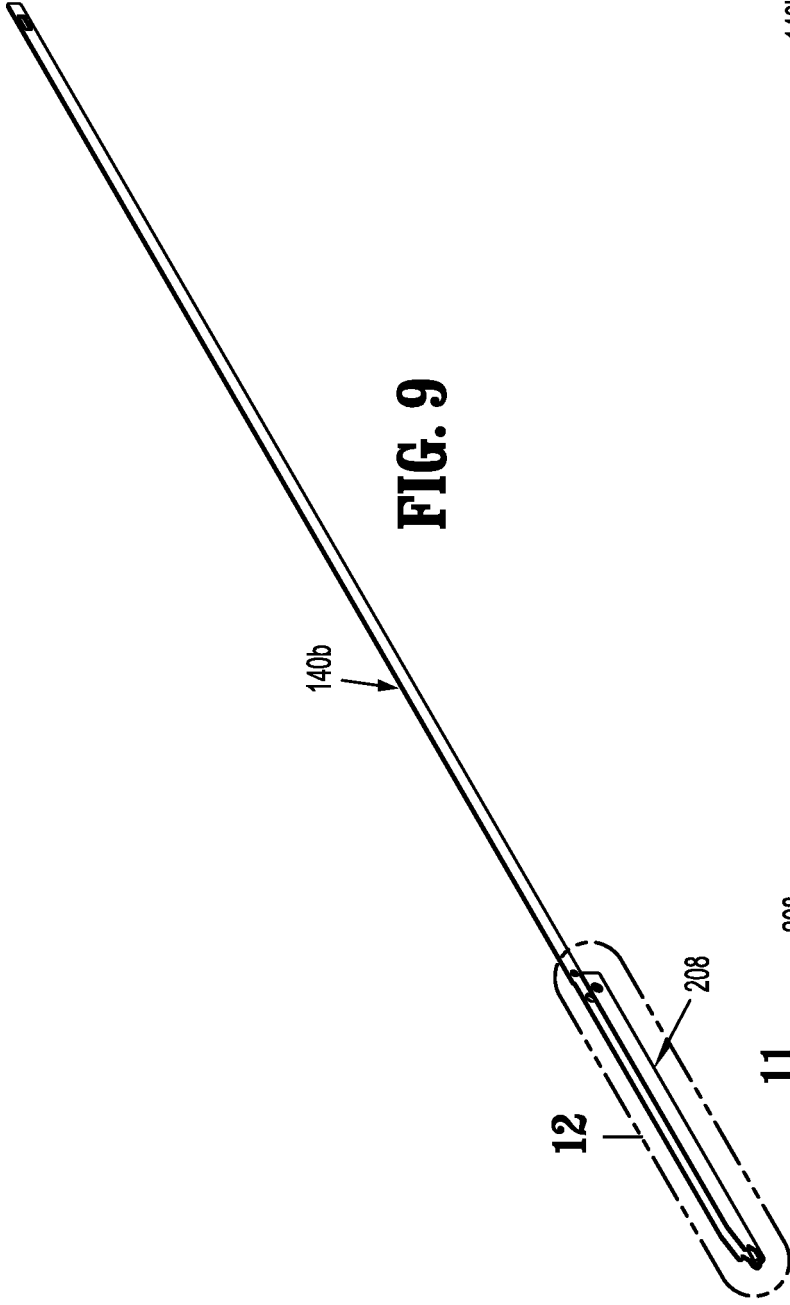

FIG. 7





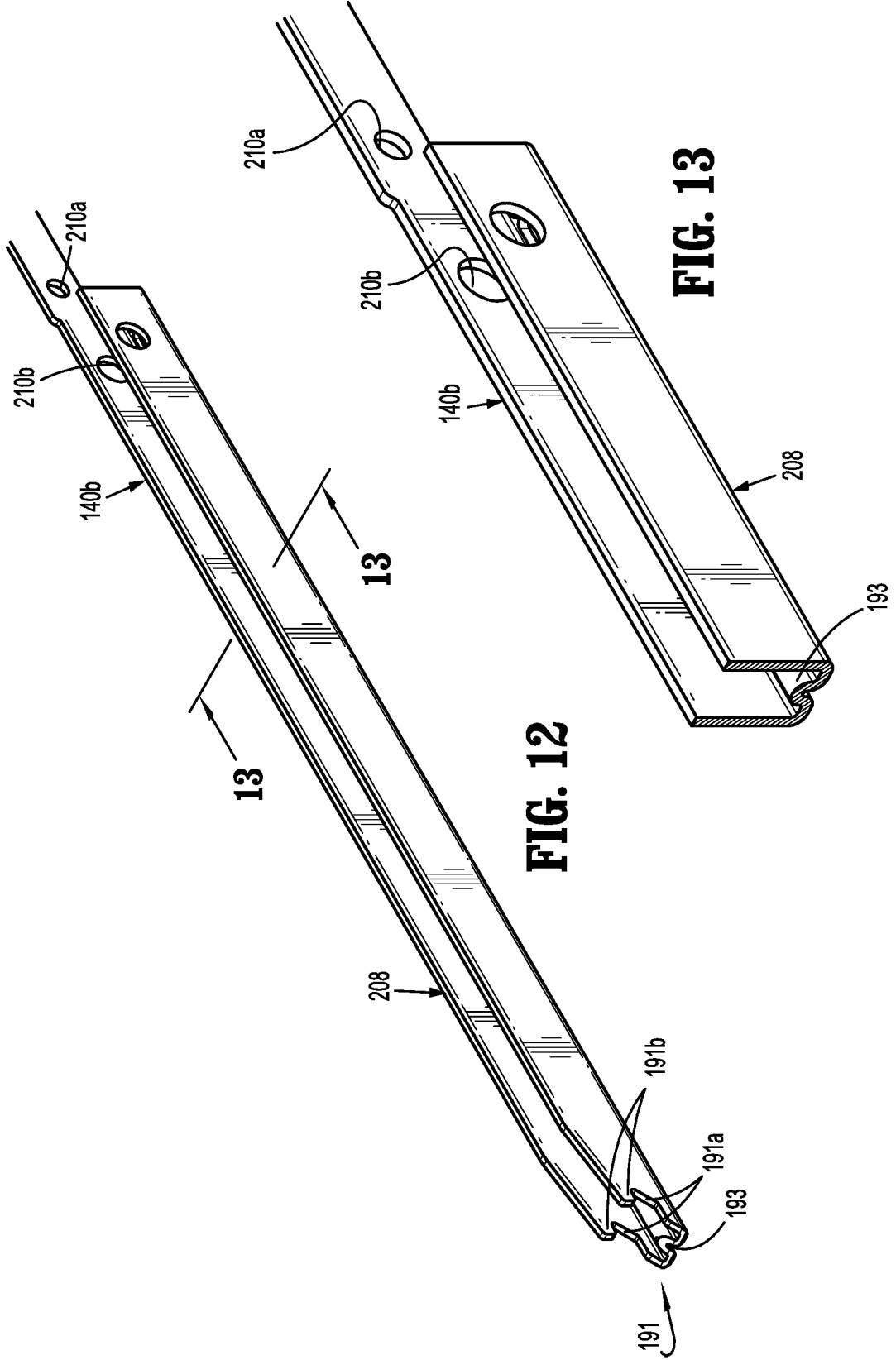

FIG. 12

FIG. 13

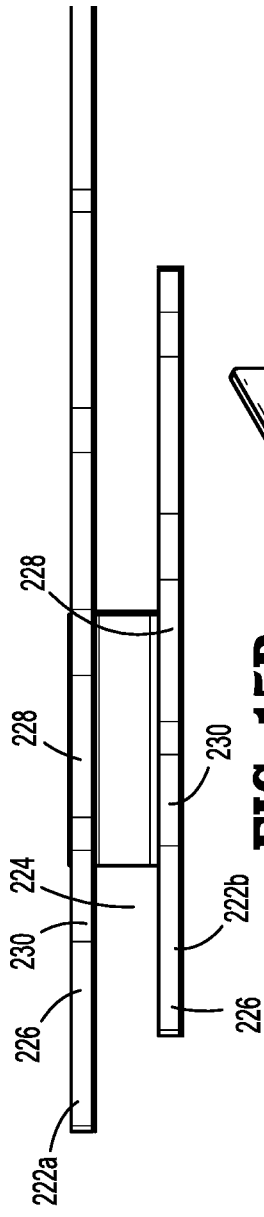

FIG. 15B

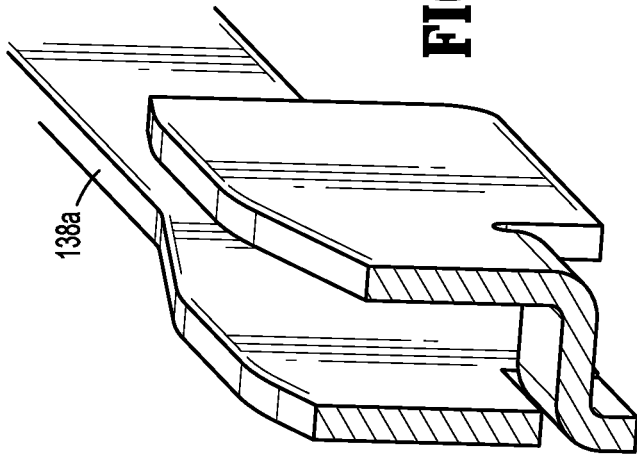

FIG. 16

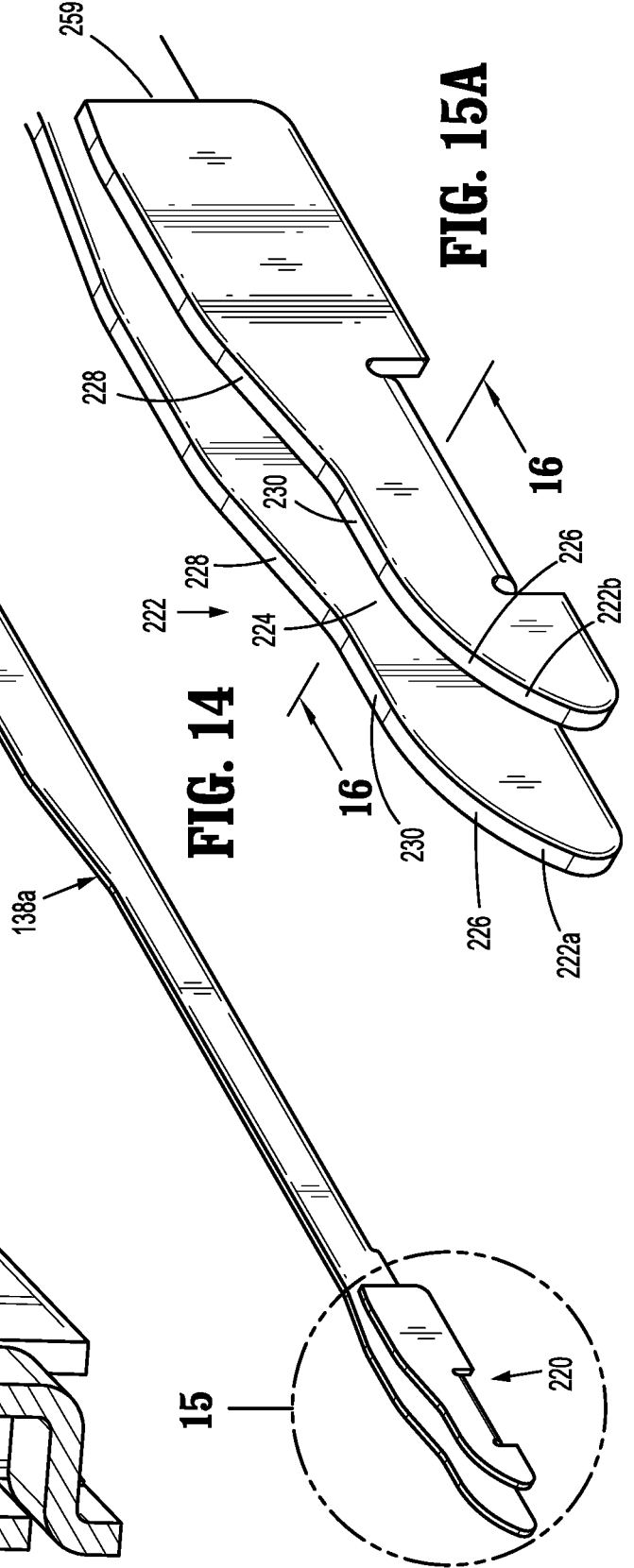

FIG. 14

FIG. 15A

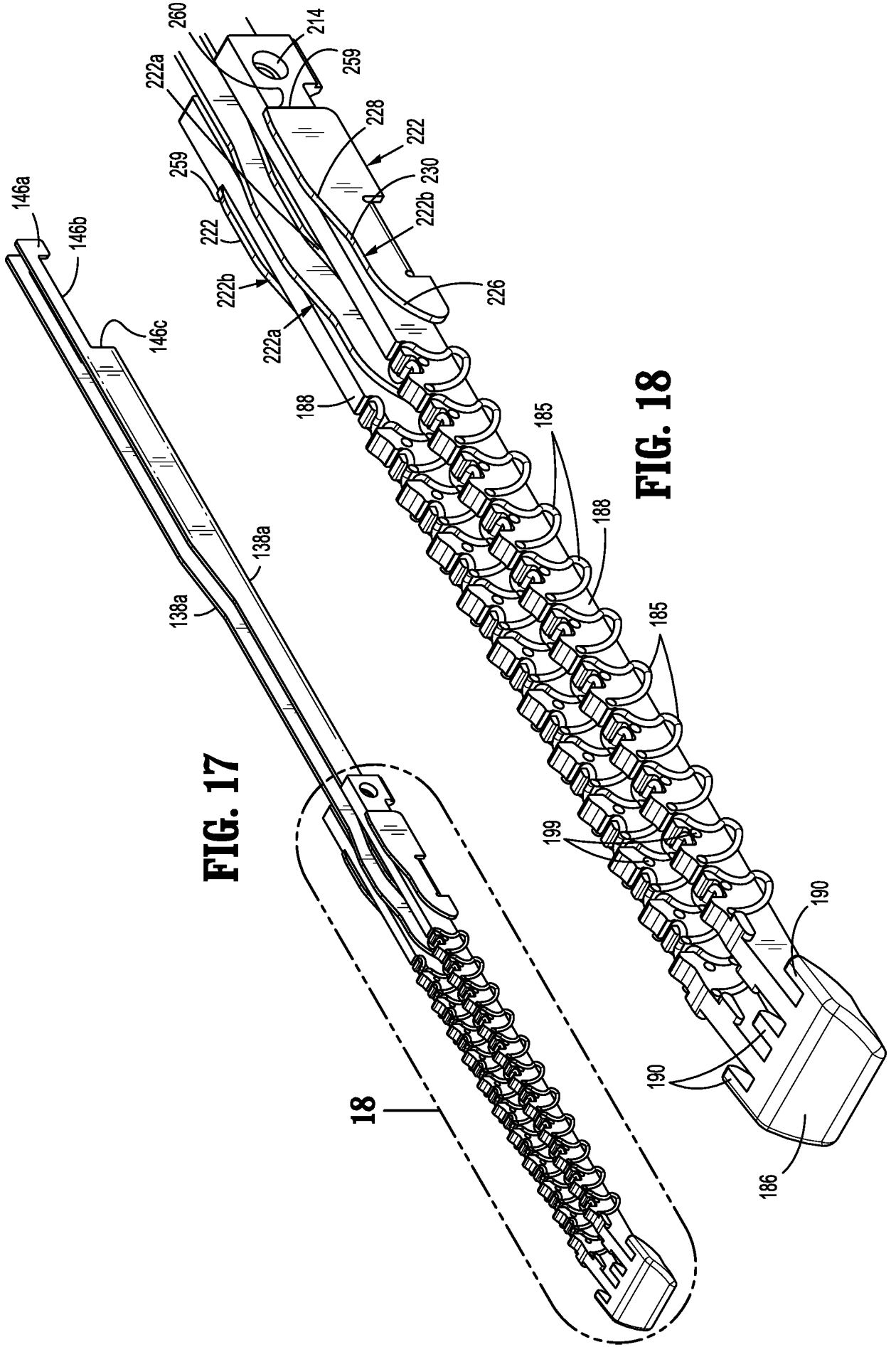

FIG. 17

FIG. 18

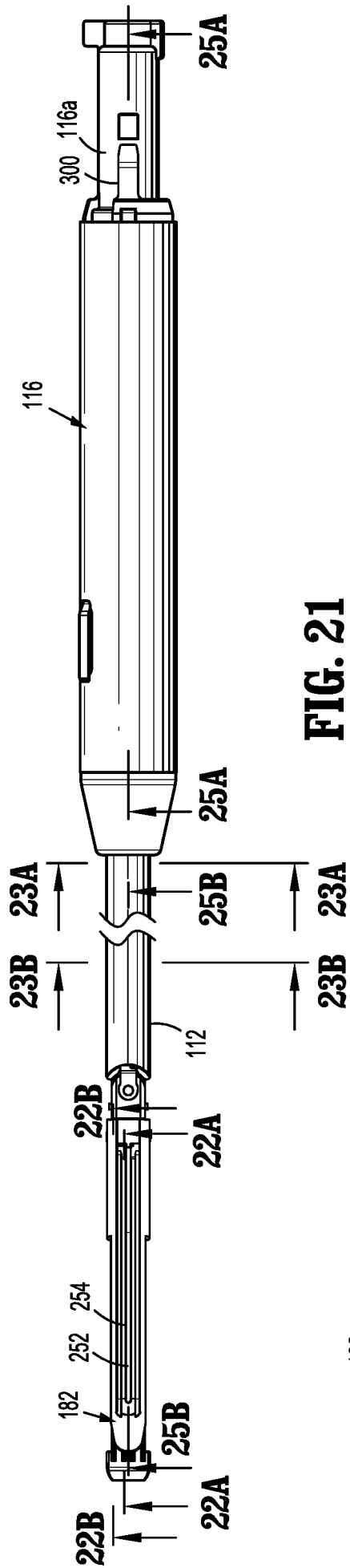

FIG. 21

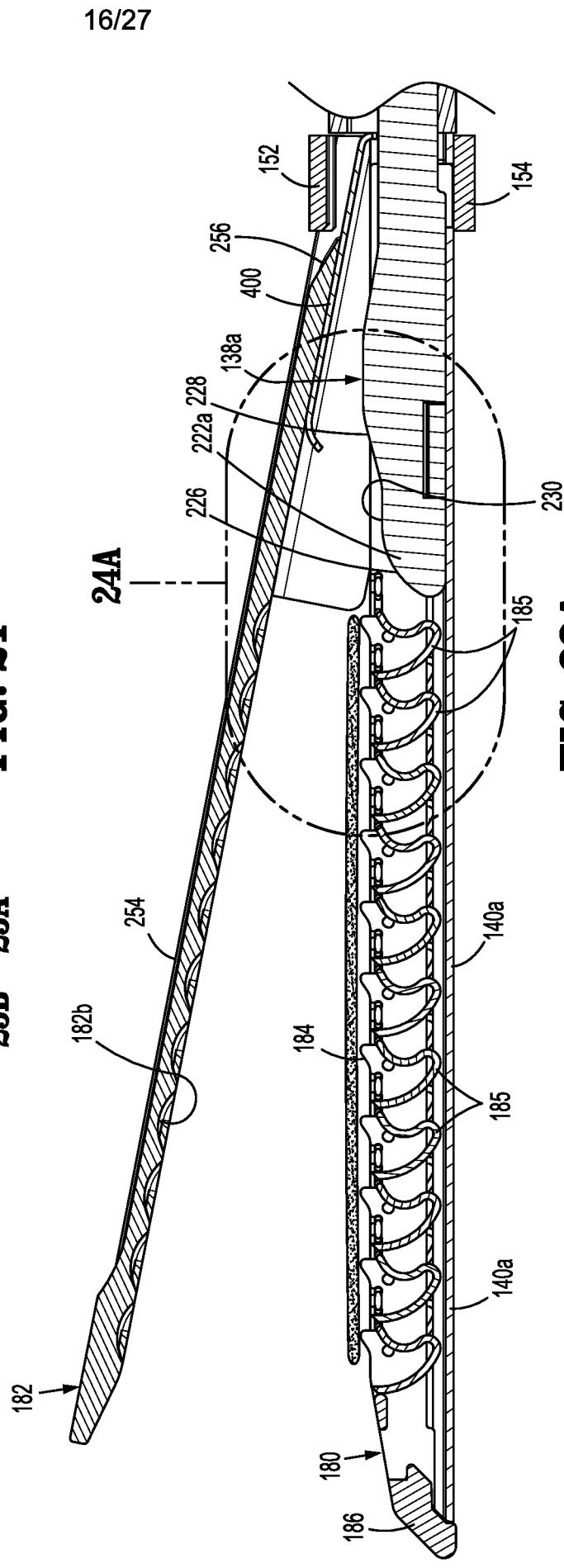

FIG. 22A

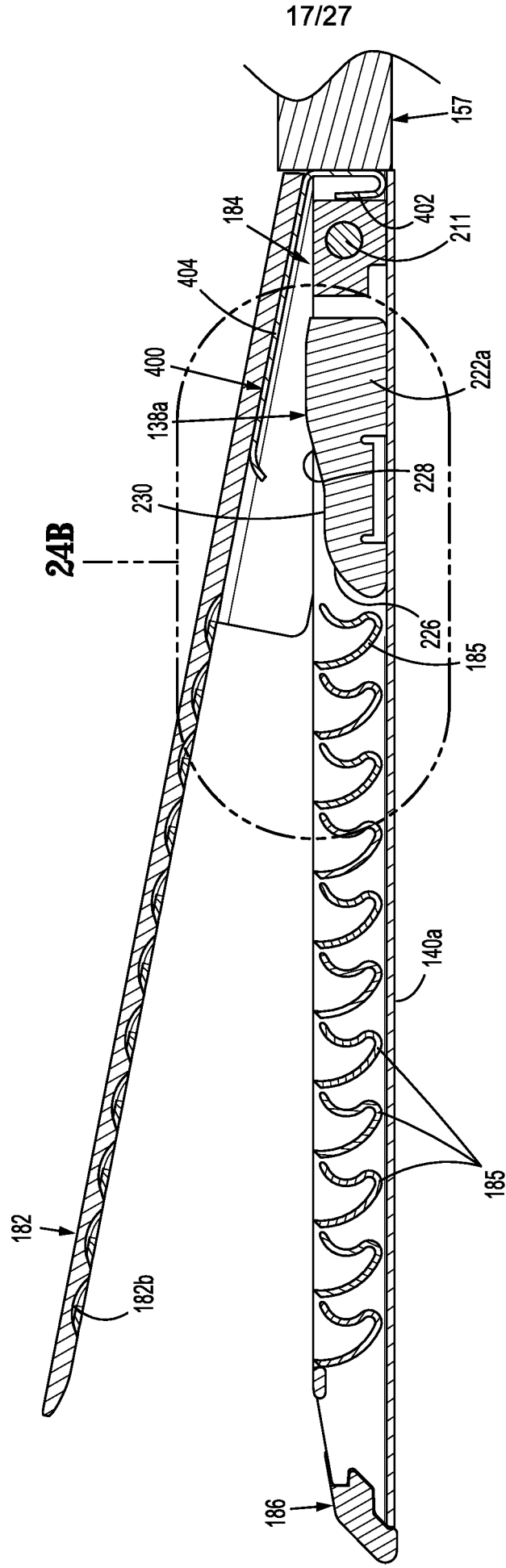

FIG. 22B

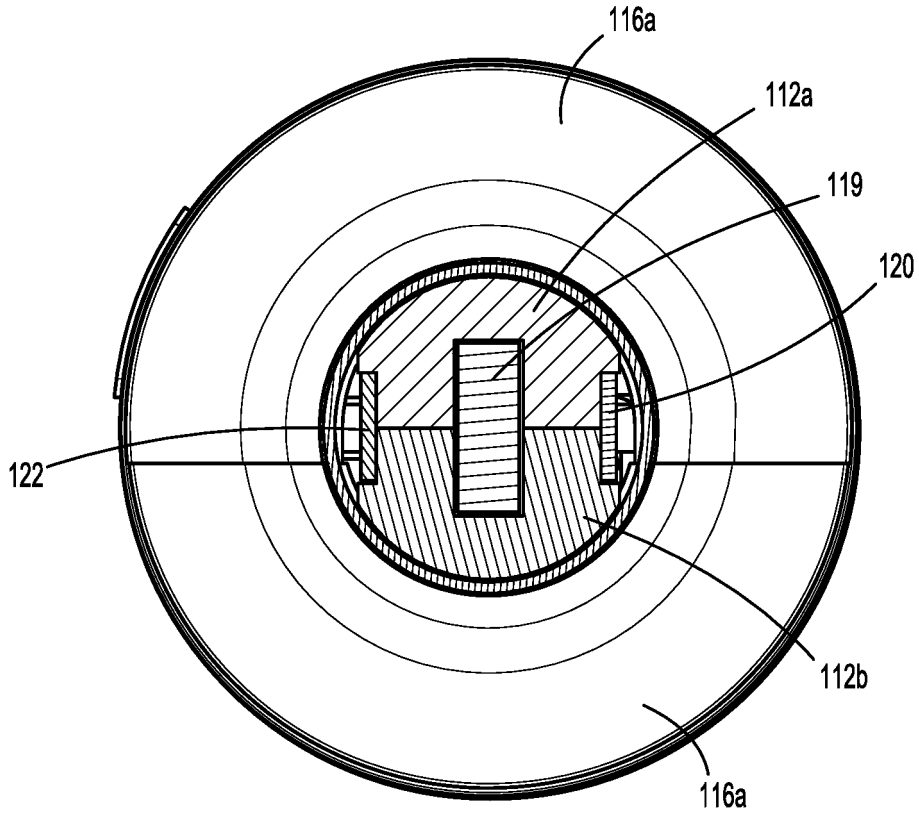

FIG. 23A

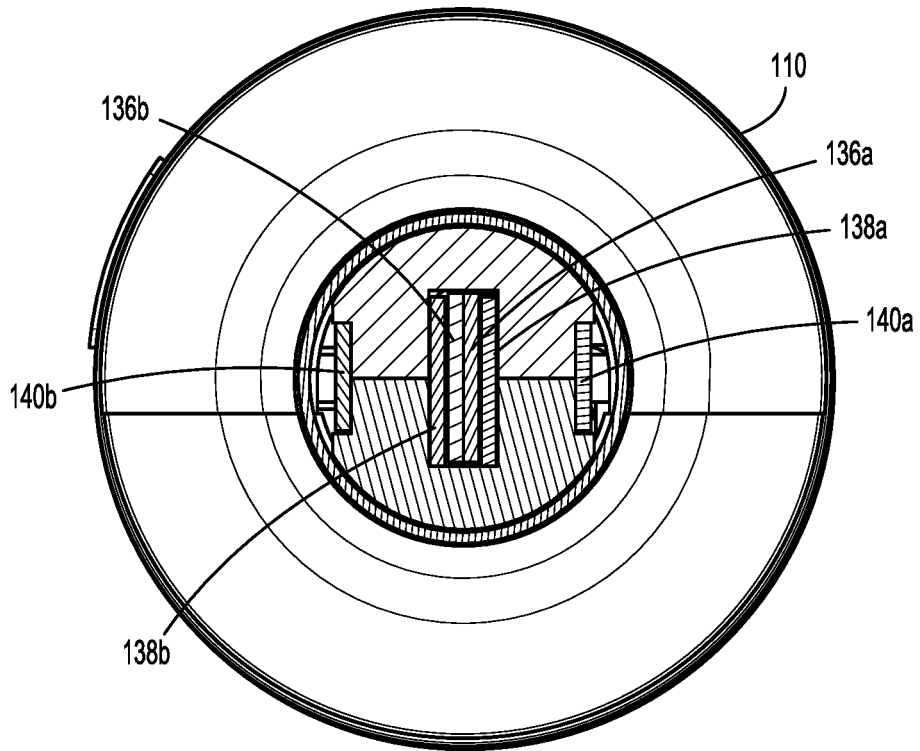

FIG. 23B

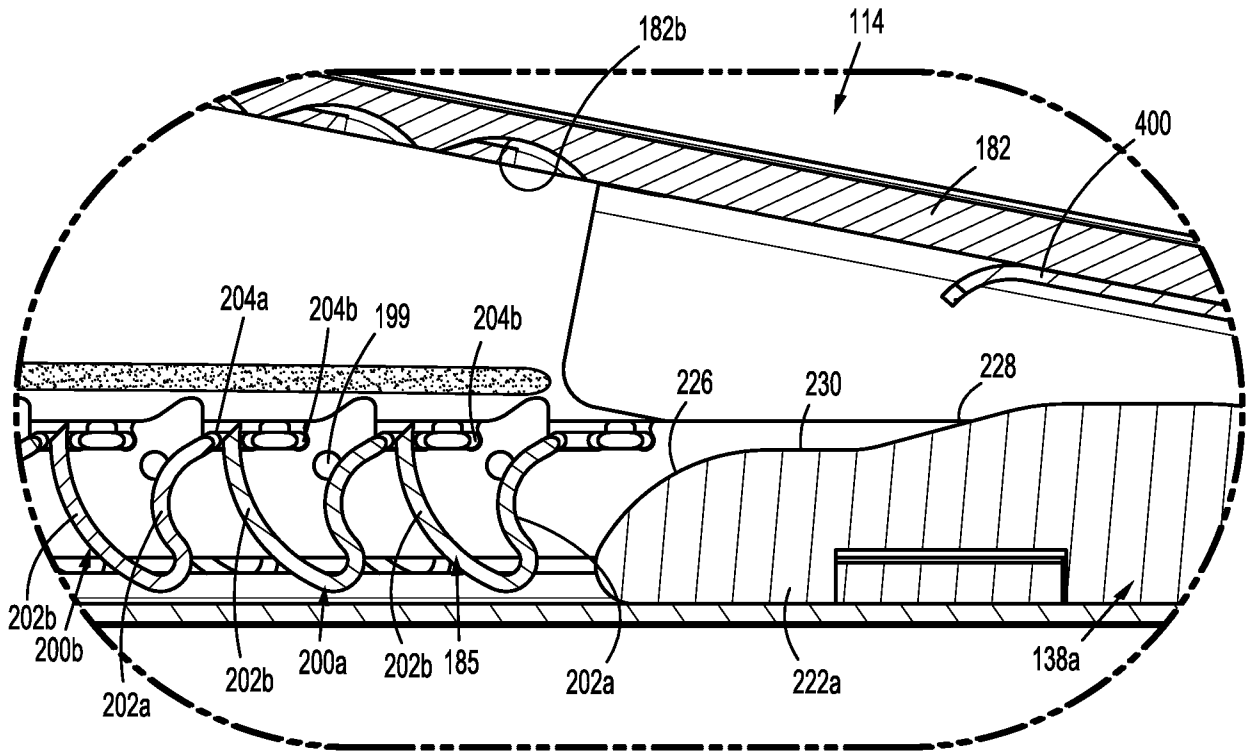

FIG. 24A

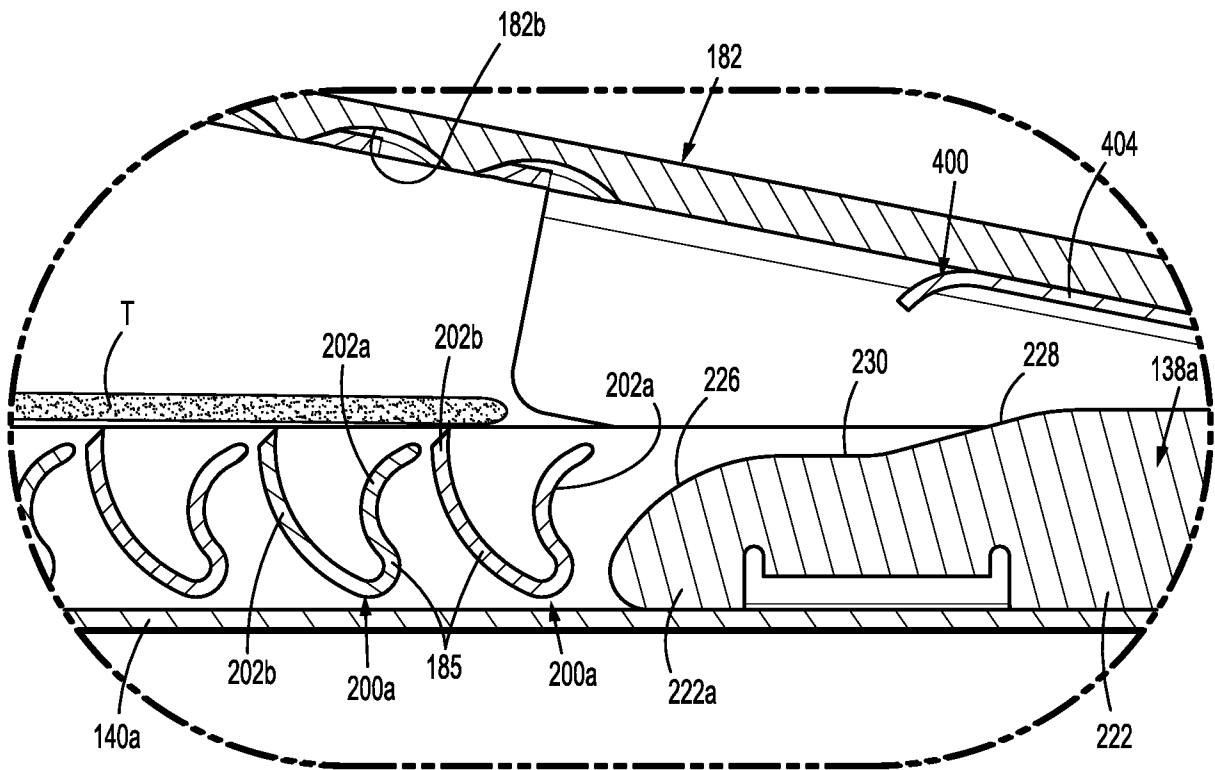

FIG. 24B

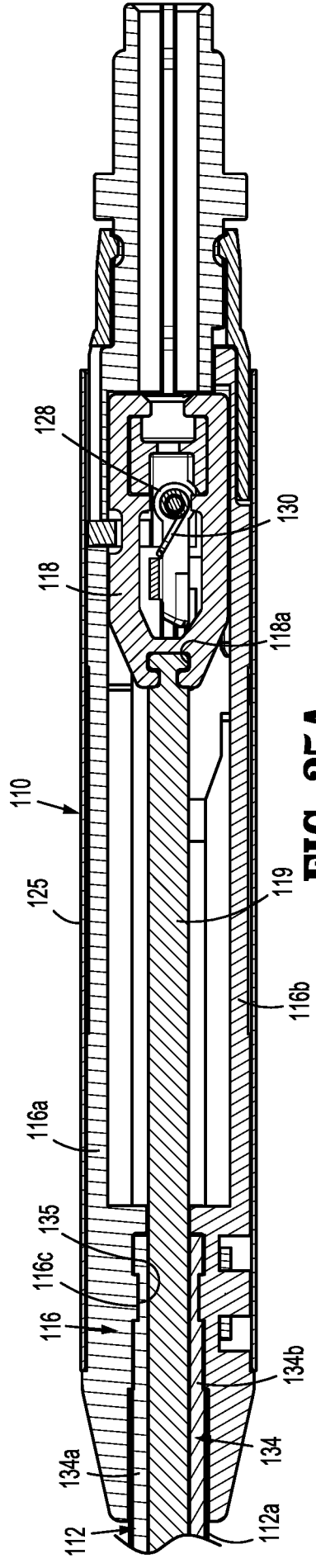

FIG. 25A

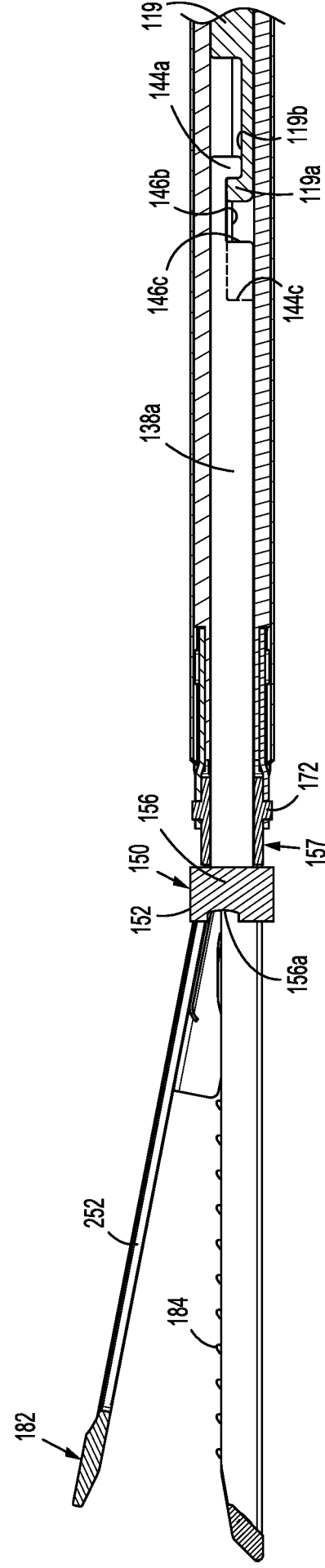

FIG. 25B

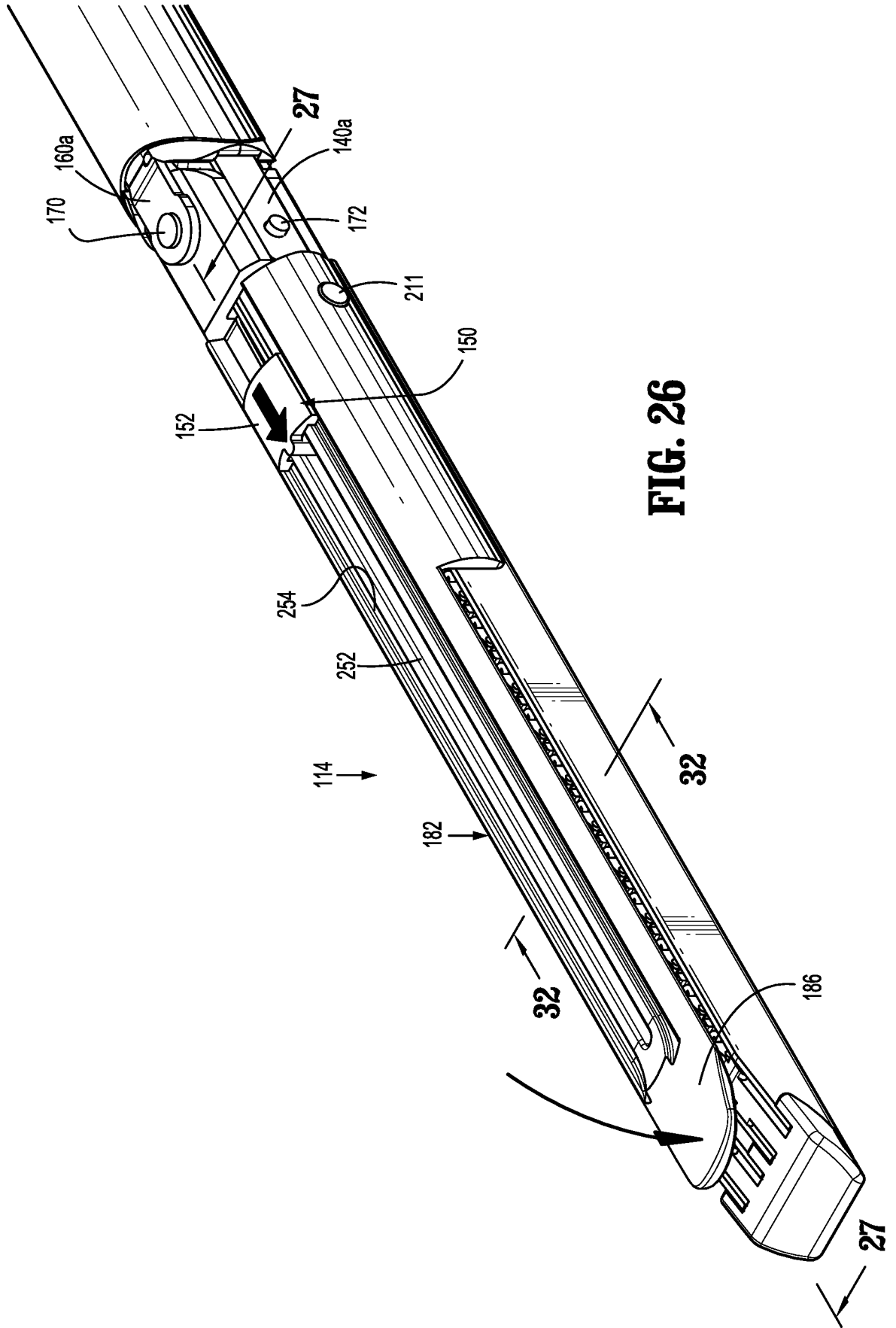

FIG. 26

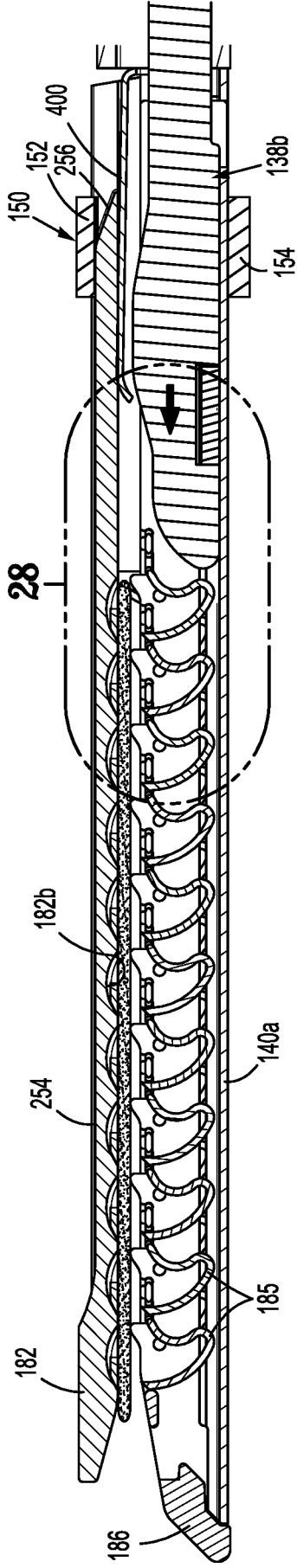

FIG. 27

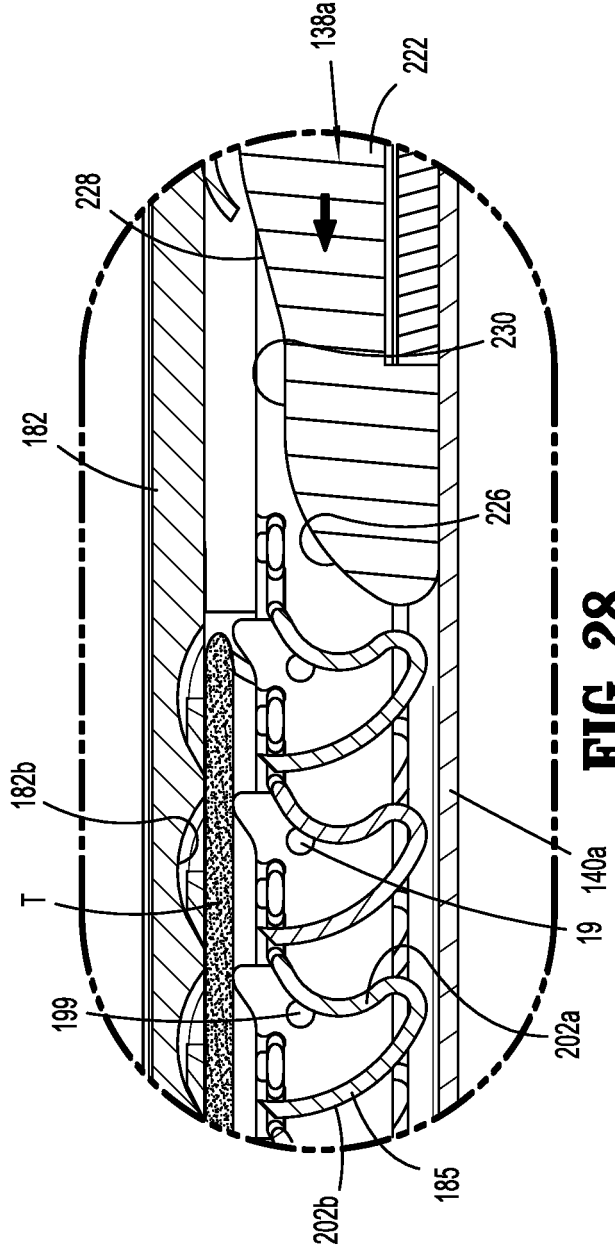

FIG. 28

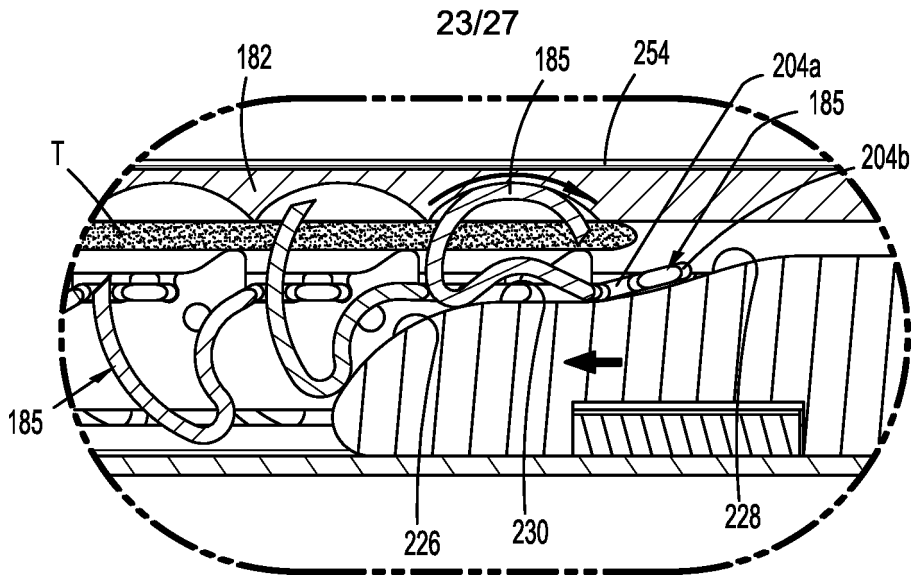

FIG. 29

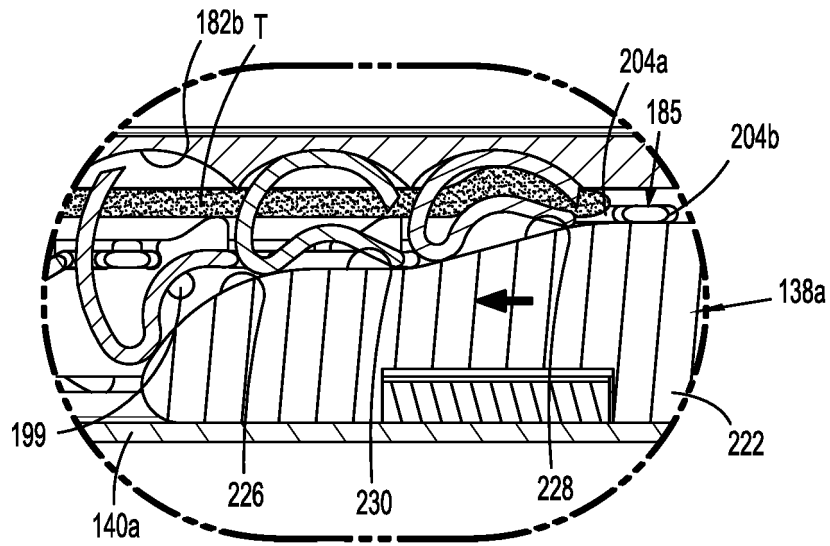

FIG. 30

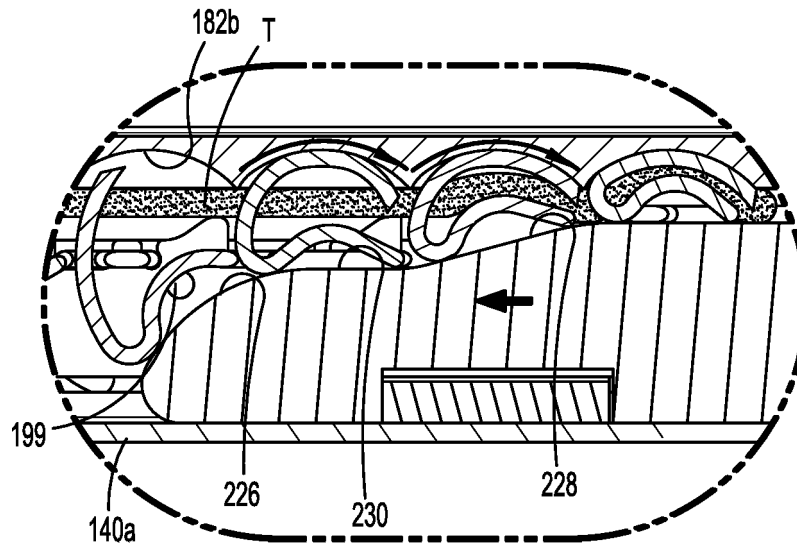

FIG. 30A

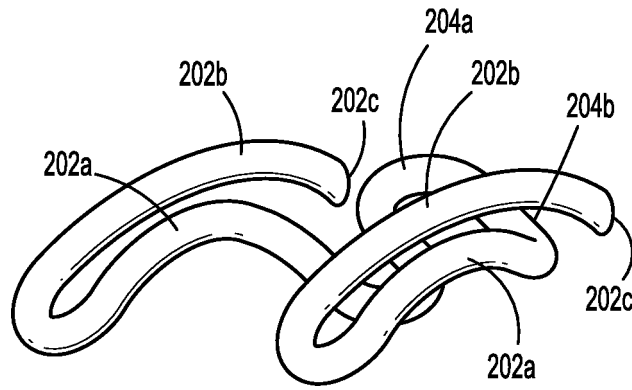

FIG. 31

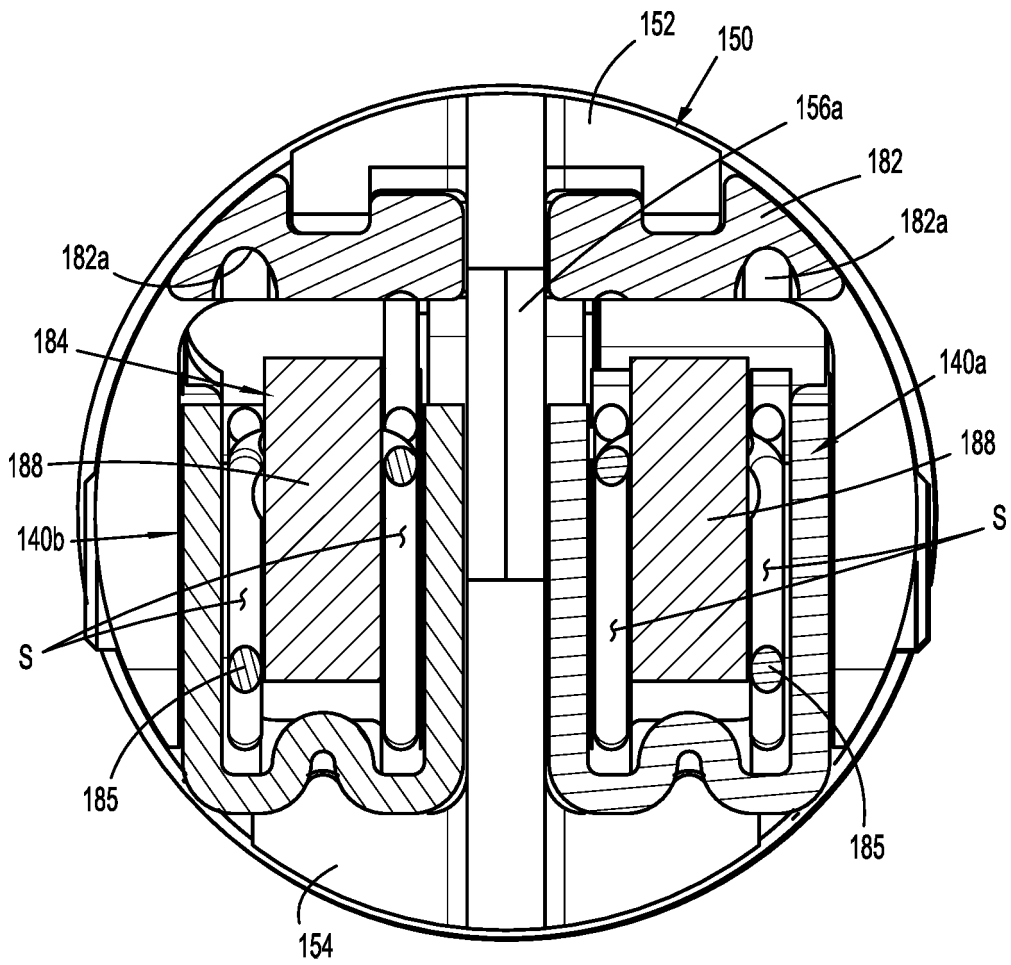

FIG. 32

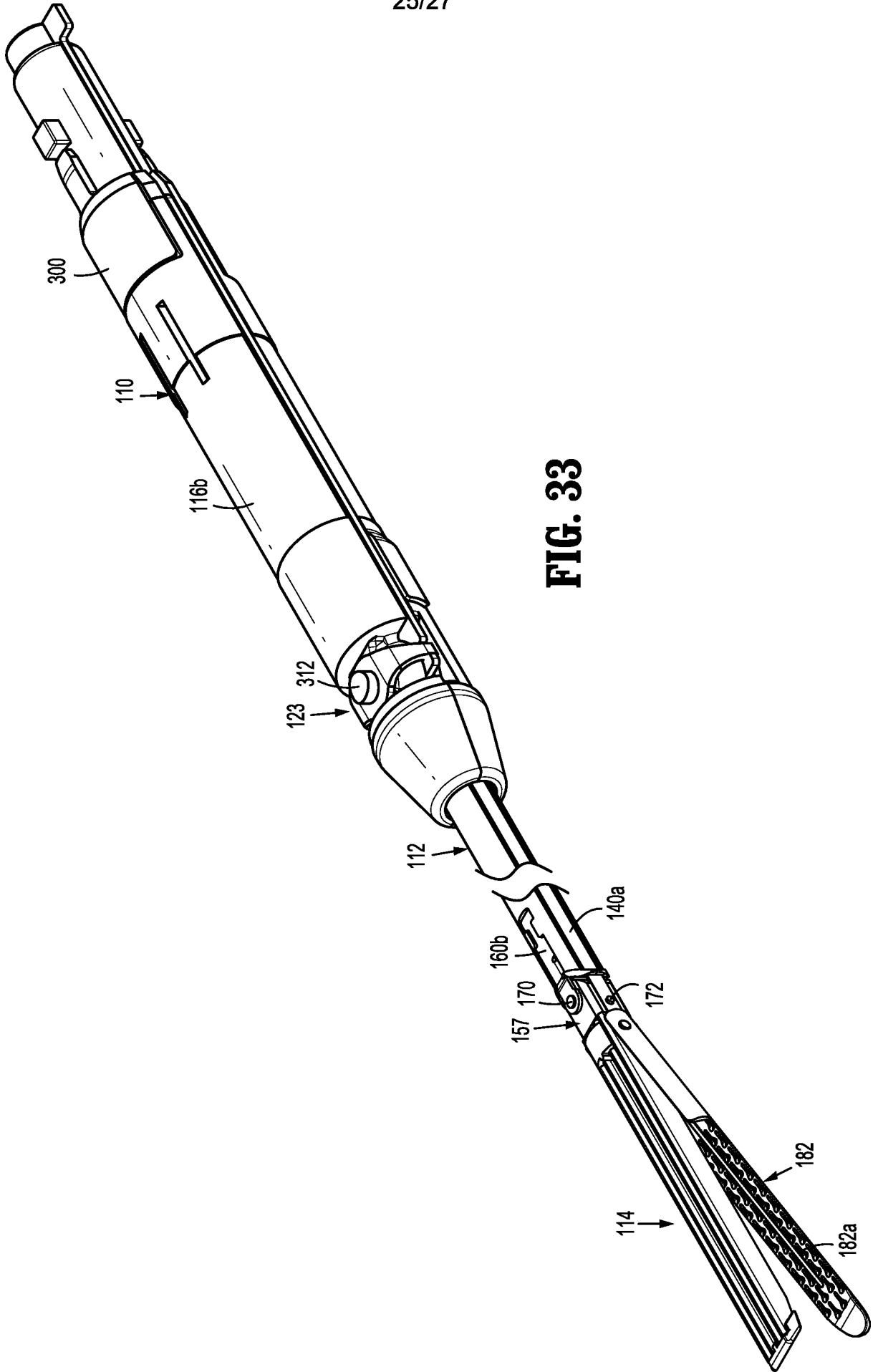

FIG. 33

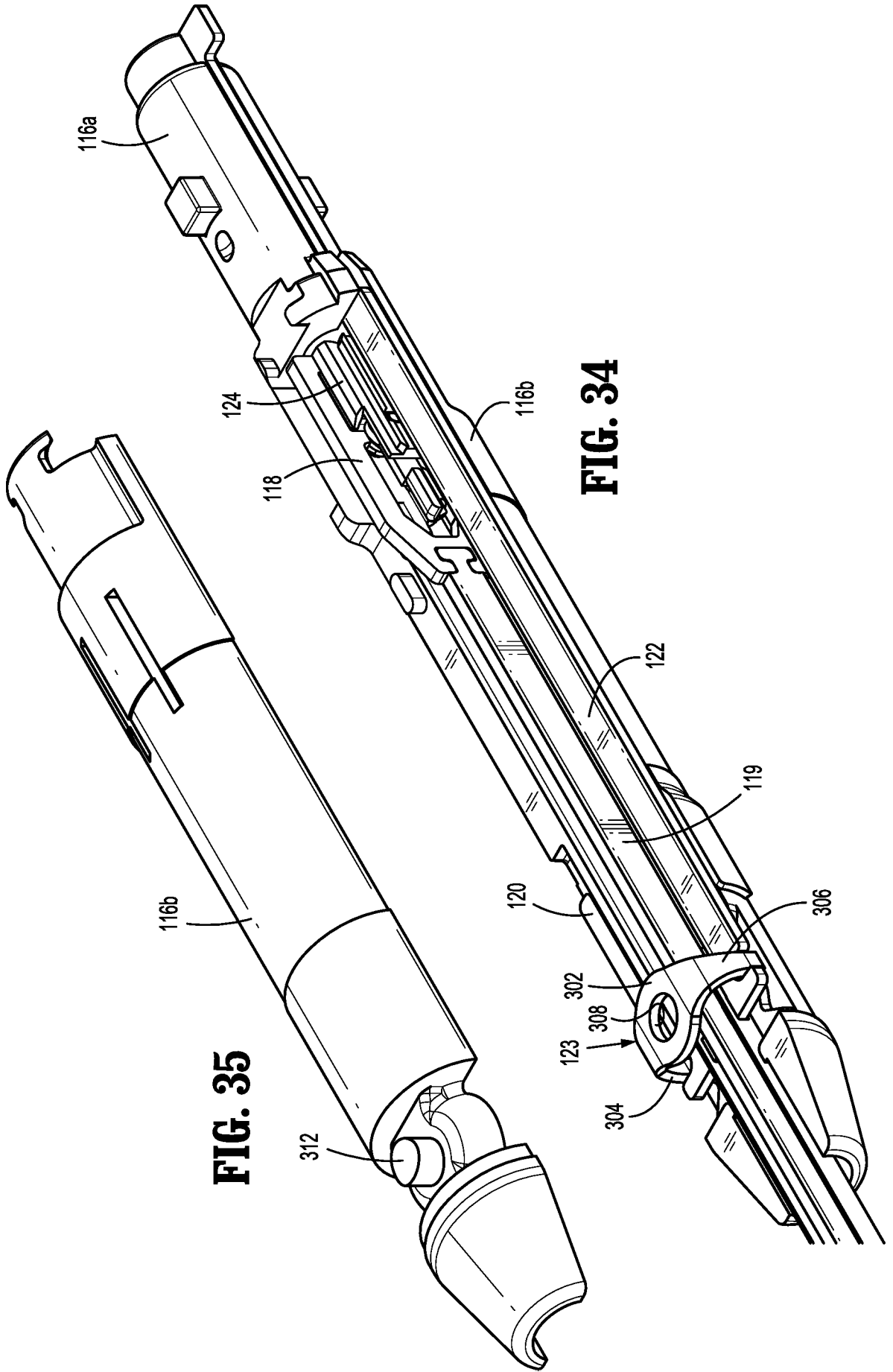

FIG. 34

FIG. 35

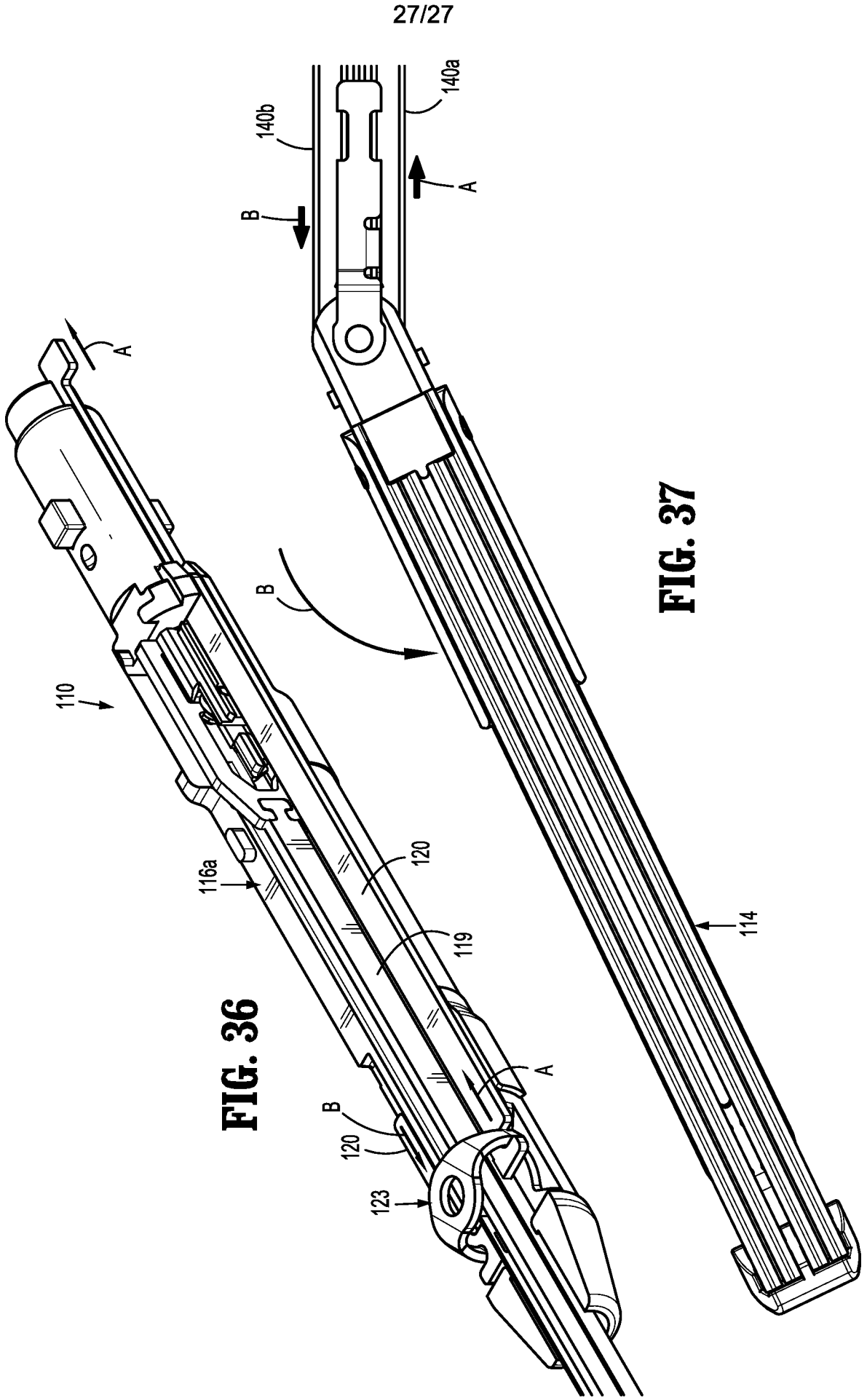

FIG. 36

FIG. 37