

*C. I. Conrod,
Sawing Shingles.*

No 11,689.

Patented Sep. 19, 1854.

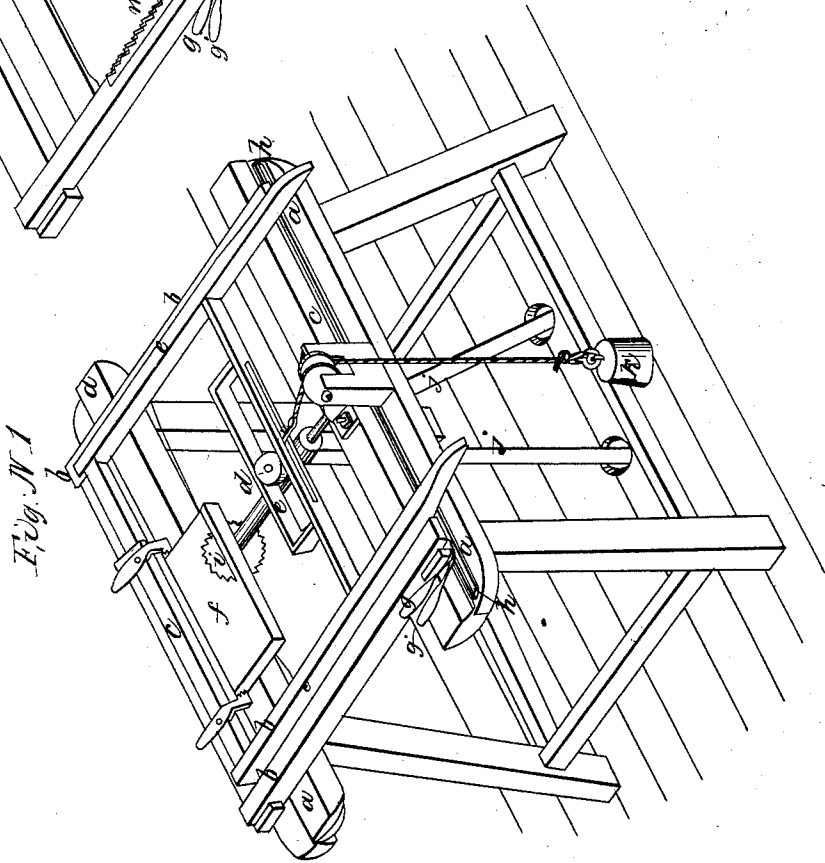
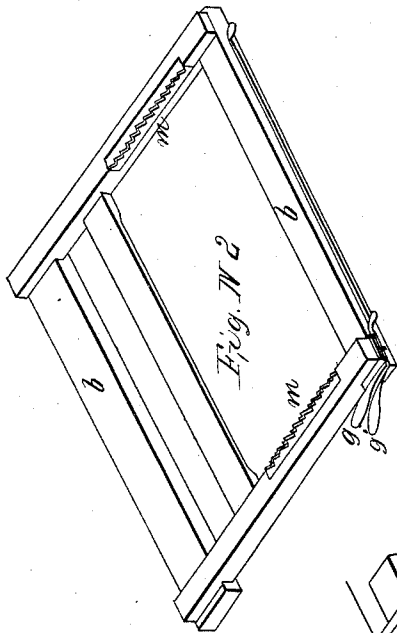

UNITED STATES PATENT OFFICE.

CHAS. I. CONROD, OF LOWER AUGUSTA TOWNSHIP, NORTHUMBERLAND COUNTY,
PENNSYLVANIA.

METHOD OF SAWING SHINGLES.

Specification of Letters Patent No. 11,689, dated September 19, 1854.

To all whom it may concern:

Be it known that I, CHARLES I. CONROD, of Lower Augusta township, in the county of Northumberland and State of Pennsylvania, have invented certain new and useful Improvements in Machines for Sawing Shingles; and I do hereby declare that the following is a full, clear, and exact description thereof, reference being had to the accompanying drawings, making part of this specification, in which—

Figure 1 is a perspective view of the machine and Fig. 2 a perspective view of the carriage frame.

The letters of reference indicate the same parts when repeated in the different figures.

The nature of my improvement consists in a new mode, and combination of parts, whereby I am enabled to gage the thickness of the shingles to be sawed, with great facility, and at either end according to the thickness and taper required.

I construct a shingle machine consisting of a strong table shaped frame, *a*, about three feet in height eight feet in length and seven feet in width which frame supports a circular saw, *i*, fixed upon an arbor which has suitable bearings in the frame *a*. Upon the two longest rails or timbers of the frame *a* are secured two iron plates *h* with flanges or ways upon which the carriage frame *b*, moves, aided by grooved casters or friction wheels. The frame *b* is furnished with an iron plate (*m*) on each of the shorter, or cross beams one of which has notches in its upper edge one inch apart, and the other notches alternately three fourths and one quarter of an inch apart. On the carriage frame *b*, and within its shorter beams there is placed what I call the register carriage or frame *c*, it has a pin or single tooth projecting from each of its under sides which rest in the notches of the plates, *m*, and is provided with dogs to grasp, and hold the block or shingle bolt *f*. About the center of the frame *c* extends a slotted piece carrying on its inner sides ways upon which the double grooved pulleys *d* traverse freely having a hooked projection from their axis (project-

ing through the slot), to which is fastened a cord which passing over a pulley journaled in a projection from the frame *a* sustains a counterbalance weight *k*, the function of which is to draw the frame *c* forward when it is elevated and disengaged from the notches in the plates *m*, or either of them by the action of the crooked levers *g* and *g'*.

When the machine is to be used the sawyer takes his station with his left hand toward the shingle bolt *f* and brings the bolt up to the saw, he strikes or presses the shorter lever *g*, which by lifting the frame *c* allows the weight *k* to move the end of the frame *c* which is nearest to the sawyer, three fourths of an inch; the power being applied to the circular saw *i* in any convenient manner the carriage frame *b* is pushed forward by the left hand and a shingle is cut, it is then drawn back, and by striking the short lever the nearest end is moved one fourth of an inch, and by striking the long lever *g'* the other end is moved one inch and another shingle is cut which will be of the same taper and thickness as the first one. The operations as above described are then repeated until the whole bolt is cut up at the rate of about twelve shingles per minute.

I am aware that shingle machines have been constructed with racks having notches at equal distances requiring much longer frames than mine to secure the equality of the shingles in size and shape; therefore such I do not claim; but

What I claim as my invention and desire to secure by Letters Patent, is—

The use or employment of the notched register plates *m*, *m*, one being constructed with equidistant notches; the other with notches placed alternately at about three fourths and one fourth of the distances of the first mentioned, in combination with the register frame *c*, its counterpoise weight *k* and the levers *g* and *g'* substantially as described and for the purposes specified.

C. I. CONROD.

Witnesses:

SAML. GRUBB,
CHAS. EVERETT.