

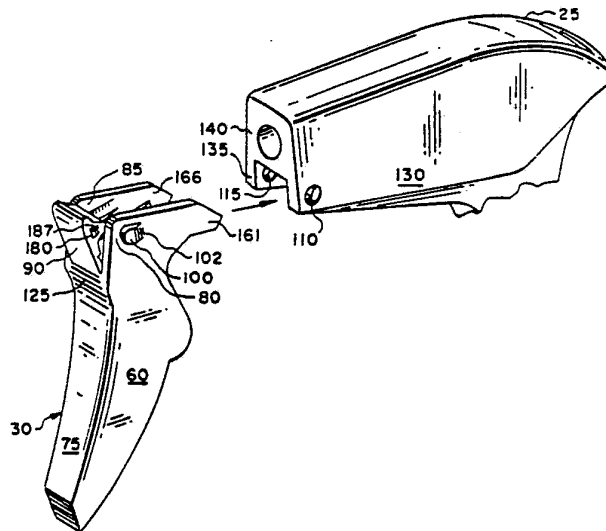

INTERNATIONAL APPLICATION PUBLISHED UNDER THE PATENT COOPERATION TREATY (PCT)

(51) International Patent Classification ⁵ : B05B 11/00, G05G 1/04	A1	(11) International Publication Number: WO 90/03226 (43) International Publication Date: 5 April 1990 (05.04.90)
(21) International Application Number: PCT/US89/04103 (22) International Filing Date: 19 September 1989 (19.09.89) (30) Priority data: 249,374 26 September 1988 (26.09.88) US (60) Parent Application or Grant (63) Related by Continuation US 249,374 (CON) Filed on 26 September 1988 (26.09.88) (71) Applicant (for all designated States except US): AFA PRODUCTS, INC. [US/US]; 1 Pine Street, Forest City, NC 28043 (US). (72) Inventors; and (75) Inventors/Applicants (for US only): MAAS, Wilhelmus, J., J. [NL/NL]; Keizerstraat 45, NL-5711 TT Someren (NL). HURKMANS, Petrus, L., W. [NL/NL]; Heikantstraat 15, NL-5712 GR Someren (NL).		(74) Agent: VIGIL, Thomas, R.; Thomas Vigil & Associates, 836 South Northwest Highway, Barrington, IL 60010 (US). (81) Designated States: AT, AT (European patent), AU, BE (European patent), BR, CH, CH (European patent), DE, DE (European patent), DK, FI, FR (European patent), GB, GB (European patent), IT (European patent), JP, KR, LU, LU (European patent), NL, NL (European patent), NO, SE, SE (European patent), US. Published <i>With international search report.</i> <i>Before the expiration of the time limit for amending the claims and to be republished in the event of the receipt of amendments.</i>

(54) Title: SNAP-IN TRIGGER**(57) Abstract**

The snap-in trigger (30) for mounting in a trigger sprayer housing (25) comprises a trigger (30) which includes flexible members (80, 85) carrying pivotal mounting elements (100, 105) which mate with corresponding elements (110, 115) in a base, e.g., the sprayer housing (25). The flexible members (80, 85) are flexed towards each other during attachment of the trigger (30) to the base, to allow easy mating of the pivotal mounting elements (100, 105, 110, 115). The trigger (30) also includes a flexible locking member (90) which can be pivoted between a first position in which the locking member is spaced apart from the vicinity of the pivotal mounting elements (100, 105, 110, 115), (e.g., during mating of the pivotal members while the flexible members are flexed together) and a second position in which the locking member (90) is positioned directly between the flexible members (80, 85) in the vicinity of the pivotal mounting elements (100, 105, 110, 115) preventing the flexible members (80, 85) from moving towards one another, and thus assuring proper mating configuration between the pivotal mounting members (100, 105, 110, 115). The locking member (90) also includes secondary locking means (120, 180) for securing it in the position between the flexible members (80, 85).

FOR THE PURPOSES OF INFORMATION ONLY

Codes used to identify States party to the PCT on the front pages of pamphlets publishing international applications under the PCT.

AT	Austria	ES	Spain	MG	Madagascar
AU	Australia	FI	Finland	ML	Mali
BB	Barbados	FR	France	MR	Mauritania
BE	Belgium	GA	Gabon	MW	Malawi
BF	Burkina Fasso	GB	United Kingdom	NL	Netherlands
BG	Bulgaria	HU	Hungary	NO	Norway
BJ	Benin	IT	Italy	RO	Romania
BR	Brazil	JP	Japan	SD	Sudan
CA	Canada	KP	Democratic People's Republic of Korea	SE	Sweden
CF	Central African Republic	KR	Republic of Korea	SN	Senegal
CG	Congo	LI	Liechtenstein	SU	Soviet Union
CH	Switzerland	LK	Sri Lanka	TD	Chad
CM	Cameroon	LU	Luxembourg	TG	Togó
DE	Germany, Federal Republic of	MC	Monaco	US	United States of America
DK	Denmark				

SNAP-IN TRIGGER
BACKGROUND OF THE INVENTION

Field of the Invention

This invention relates to improvements in the construction
5 and assembly of pivotal levers, generally, and to triggers for
sprayers, in particular. The trigger of this invention can be
integrally molded and includes structural features which permit
virtually instantaneous snap-in attachment to a pivot base, such
as to the housing of a sprayer, for secure, pivotal attachment.

10 Pivotal levers have widespread utility in industrial
articles of manufacture, for example, as triggers in sprayers.
Such levers should be pivotally attached securely to a base,
such as, for example, a trigger to a sprayer housing. The
design and construction of these levers is in response to a
15 number of competing forces. For example, there is a need for
low cost manufacture of the trigger element itself, for low cost
trouble free assembly, i.e. attachment of the trigger to a spray
head, for smooth operation, once assembled, and for long lasting
trouble free operation.

20 All these considerations must be addressed effectively in
order to provide the manufacturer of finished assemblies with
a product of truly competitive cost, and the consumer user with
a product of economic, completely satisfactory, trouble free
construction.

25 Description of the Prior Art

There have been many suggestions for improving the design,
construction, and assembly of such levers. For example, the
McKinney U.S. Patent 4,161,288 suggests retaining the trigger
by providing a spiral chamber in the trigger into which pivot
30 lugs on the sprayer housing can be maneuvered.

The Martin U.S. Patents Nos. 4,480,768, 4,489,890, and
4,503,998 are sister patents which suggest providing the pivot
attachment elements on flexible portions of both the trigger and
sprayer housing, so that both of these sets of elements can flex
35 during mating attachment, in order not to excessively damage the
pivot lugs, etc. However, both sets of the flexible portions
remain flexible, after attachment of the trigger to the sprayer,
and these patents leave unresolved, the problem of dislodgement
of the pivot lugs from their respective sockets, during forcible
40 pivoting operation of the trigger, due to the flexibility of the

lug-carrying portions of the trigger and the sprayer.

The Tada U.S. Patent 4,153,203 suggests providing a lever (trigger) with flexible lateral walls carrying cylindrical pivot lugs, and addresses the problem of disengagement during pivotal operation by teaching to provide rigid "stopper boards" on the body which project from the body to bear against the insides of those flexible portions of the trigger which carry the pivot elements. This is purported to prevent the walls carrying the pivot elements from being thrown inward, thereby preventing unmating of the respective pivot lugs and sockets. This patent is silent, however, as to how, on one hand, the rigid "stopper boards" can, in the same configuration, allow assembly movement or positioning of the trigger unit to bring the pivot lugs into a pre-mating, coaxially aligned orientation with their corresponding sockets on the sprayer housing for mating of these pivotal linking elements without damage, and yet after mating, prevent the movement of these same flexible elements to that same pre-mating, coaxially aligned assembly position which would then allow disengagement of the pivot elements.

There is a need to provide the art with an economical snap-in trigger which will provide secure, trouble free operation for the life of the sprayer, and which allows virtually instantaneous attachment to the sprayer housing, either manually or by machine.

SUMMARY OF THE INVENTION

The present invention provides a snap-in lever which will not be damaged during the assembly process to a sprayer, and which will maintain a secure assembled position to function properly for the life of the sprayer.

In accordance with a preferred aspect of the present invention, the lever, or trigger, is provided with three flexible members, e.g., panels. Two of these members, or panels are bilateral, and carry pivot structure for mating with corresponding elements on a base, or sprayer housing, and for providing pivotal attachment thereto. The third flexible member or panel constitutes a locking system, part of which is transverse to the bilateral panels, and is capable of flexing or hinging into two positions. The first position is one in which the third panel will not interfere with the motion of the pivot structure on the flexible bilateral panels prior to

attachment to the base. The second position, the locking position, is one in which at least a portion of the third, i.e., transverse panel is positioned between the flexible bilateral panels, and prevents relative movement of the bilateral panels
5 towards each other, thereby positively locking the pivot structure in proper position, by preventing disengagement of the mating pivot elements from the base.

Hence, as used herein, the term "locking" as applied to the flexible bilateral members or panels doesn't imply that the
10 trigger is rendered immovable, but just that the pivot structure are secured in proper operating pivotal position.

In a more preferred aspect of this invention, the lever, or trigger, is a unitary molded element fashioned from strong, resilient, flexible polymer. In such a preferred embodiment,
15 the third panel is molded in the first position referred to above, namely, in a position in which it will not interfere with the inward flexing of the pivot structure bearing bilateral panels. The third, locking, element is furthermore maintained in that open position during shipping, packaging, or other pre-
20 assembly handling by means of integral, frangible, molded bridge webs extending between portions of the third panel, and respective adjacent portions of the bilateral panels. These integral webs are easily ruptured upon the application of sufficient force to accomplish hinging, or pivoting of the third
25 panel into its locking position between the bilateral panels, during the final instant of assembly attachment of the lever to its base.

In addition, the third hinged panel, and the body of the lever is provided with a second locking arrangement for
30 maintaining the third panel in the second, or locking position, in opposition to its tendency, due to molecular memory, to spring back to the first, open, molded position.

According to the invention, there is provided a trigger for mounting to a trigger sprayer housing having trigger pivot
35 mounting means therein, said trigger comprising an elongate body having a top portion, said top portion including (a) first and second flexible side panels each carrying pivoting structure for mating with the trigger pivot mounting means and (b) flexible, movable locking means for locking said pivot structure in
40 pivotal engagement with the trigger pivot mounting means when

said locking means are moved relative to said side panels into a locking position.

Further according to the invention, there is provided a pivot assembly in a trigger sprayer comprising a trigger having
5 an elongate body and a top portion and a sprayer housing having a recess, said assembly comprising trigger pivot mounting means in said recess and said top portion of said trigger body including (a) first and second flexible side panels each carrying pivoting structure for mating with the trigger pivot
10 mounting means and (b) flexible locking means for locking said pivot structure in pivotal engagement with the trigger pivot mounting means when said locking means are moved relative to said side panels into a locking position.

BRIEF DESCRIPTION OF THE DRAWINGS

15 Fig. 1 is a perspective view of a trigger sprayer assembly attached to a container.

Fig. 2 is a perspective view of a detached unitary molded trigger constructed in accordance with the teachings of the present invention.

20 Fig. 3 is an outside elevational view of the trigger of Fig. 2, taken along line 3-3 of Fig. 2.

Fig. 4 is an inside elevational view of the trigger of Fig. 2 taken along line 4-4 of Fig. 2.

25 Fig. 5 is a cross sectional view of the trigger of Fig. 2 taken along line 5-5 of Fig. 4.

Fig. 5a is a top view of the trigger taken approximately along line 5a-5a of Fig. 5.

30 Fig. 6 is a perspective view of the trigger and a sprayer housing illustrating the alignment of the trigger and the sprayer housing, prior to assembly insertion of the trigger into the sprayer housing.

Fig. 7 is a perspective view illustrating partial insertion of the trigger into the sprayer housing.

35 Figs. 8a, 8b, and 8c are fragmentary, cross sectional views of the trigger and the sprayer housing taken along line 8-8 of Fig. 7, and illustrates sequential positions of elements during the mating insertion of the trigger into the sprayer housing or base.

40 Fig. 9 is a perspective, cut-away view of the top of the trigger and shows the trigger in fully inserted position,

pivotaly attached to the sprayer housing or base.

Fig. 10 is a fragmentary cross sectional view of the trigger and sprayer housing taken along line 10-10 in Fig 9, illustrating the attached, unlocked configuration of the trigger with the third, or hinged panel shown in the open position.

Fig. 11 is a fragmentary cross sectional view of the trigger and sprayer housing as shown in Fig. 10, except that the third, hinged panel is shown moved into its locking position.

DETAILED DESCRIPTION OF PREFERRED EMBODIMENTS

10 The broad aspects of the present invention are illustrated herein by reference to a specific preferred embodiment, namely, by reference to a trigger sprayer comprising a trigger and a sprayer housing. This is not intended to limit the scope of the invention, which is defined in the appended claims.

15 Considering Fig. 1, a trigger sprayer assembly 20 is shown comprising a sprayer housing 25, and a trigger 30. The trigger-sprayer assembly 20 is shown attached to a container 35 by means of a screw cap 40, rotatably attached to the sprayer housing 25.

20 A dip tube 45, other elements 50 associated with a pumping mechanism, and a nozzle 55 are not part of the novel aspects of the present invention, and, for the purposes of this specification, are to be considered conventional. Hence, these structures, and other operational elements associated with the sprayer housing 25, apart from the novel lever, or trigger 30 and associated elements on the sprayer housing or base, will not be described in any further detail.

Turning now to the details of construction of the trigger 30, a preferred illustrated embodiment is an integral molded unit comprising side panels 60, 65 transversely joined by stiffener ribs 70, 72, and by front panel 75. (See Figs. 4 and 9) Side panels 60, 65 include respective flexible end portions 80, 85, and the front panel 75 includes flexible locking end panel or flap 90. Side panels 60, 65 are also stiffened by respective ribs 81, 86. These ribs 81, 86 are preferably of a wedge shape, perhaps best illustrated in Fig. 5a, in order to maintain the correct spacing of side panels 60, 65 for assembly purposes, and yet do not interfere with the flexing of flexible end portions 80, 85 towards each other. It is noted that in the illustrated embodiment, the direction of placement of ribs 81,

35
40

86 is generally parallel to the axis of the flex or bend of side panels 60, 65 in the vicinity of flexible end portions 80, 85.

Flexible end portions 80, 85 carry pivot pins or lugs 100, and 105, respectively, for mating with respective, corresponding sockets 110 and 115 (see Fig. 6) in the sprayer housing 25. (In an alternative embodiment, not shown, the pivot lugs can be carried by the spray head 25, and the pivot sockets can be carried by the trigger, without departing from the spirit or scope of this invention.)

10 It is noted that pivot lugs 100, 105 are truncated, so that its walls include a round portion 101, 106, and an opposite ramp portion 102, 107. (See Figs. 3 and 4.) The ramp portions 102, 107 are positioned to encounter the sprayer housing 25 during insertion of the trigger 30 into the sprayer housing 25, 15 during assembly.

Two slots 120 (Fig. 2) are formed in the inner wall surface of the flexible portion 80, 85 of the side wall 60 and side wall 65, respectively, behind lugs 100, 105.

20 It is noted that in Fig. 1 the inged end panel 90 of front panel 75 is positioned spaced-apart from the vicinity of pivot elements (lugs 100, 105) on th flexible end portions 80, 85 of the side panels 60, 65.

A flexible web bridge 125 or hinged area 125 of reduced thickness between the end panel 90 and front panel 75 maintain 25 this configuration of the trigger 30 during the preinsertion and assembly in order to provide, at the moment of assembly insertion of the trigger 30 into the sprayer housing 25, flexible free ends 80, 85 which can be easily flexed towards each other. Should the hinged end panel 90 be forced out of the 30 "open" configuration shown in Fig 1, and into the "locking" configuration shown in Fig 11, prior to insertion assembly of the trigger 30 to the sprayer housing 25, it would be impossible to flex the free end portions 80, 85 inwardly and thus pivot lugs 100, 105 would be severely damaged.

35 Referring now to Fig. 6, trigger 30 is shown aligned for insertion, during assembly, into the sprayer housing 25. Both sockets 110, 115 are visible in Fig. 6, and are shown located in respective rigid side panels 130, 135. Fixed maintenance of rigid panels 130, 135 in the exact spaced-apart dimensions 40 shown, is assisted by integral end face 140 of sprayer housing

25 and recess wall 147 which extends between panels 130, 135, and which assist in preventing even the slightest movement of side panels 130, 135 to or from each other.

Referring to Fig. 7, trigger 30 is shown partially inserted
5 between spray head panels 130, 135, and Figs. 8a, 8b, and 8c show relationships between elements during the continuing insertion of the trigger 30 into the sprayer housing 25.

In Fig 7, the significance of ramp portions 102, 107 of pivot lugs 100, 105 becomes clear. Hence, as the trigger 30 is
10 moved in the general direction of the arrow, so are the ramp portions 102, 107 of lugs 100, 105 which first encounter the ends of sidewalls 130, 135. Continued inward insertion of the trigger 30 into the recess 145, defined by wall 147, sidewalls 130, 135 and end wall 140 and associated parts of the sprayer
15 housing 25, causes the "ramping-in" of the flexible end panels 80, 85 towards each other, allowing lugs 100, 105 to pass between rigid sidewalls 130, 135 of the sprayer housing 25, without damage.

Alternatively, manual or machine pressure against the outer
20 surfaces of flexible ends 80, 85 in the vicinity of lugs 100, 105 causes the inward flexing which will allow lugs 100, 105 to clear and enter recess 145, and to travel within recess 145 easily.

Also, as an alternative, the trigger 30 can be mated with
25 the sprayer housing 25 by insertion into recess 145 from other directions, for example, along the path indicated by the arrow marked "B" in Fig. 7.

Fig. 8a shows the initial relationships, as the trigger
30 is first inserted, along the arrow marked "A" in Fig. 7, and to the extent shown in Fig. 7. In this illustration, the ends of flexible bilateral wall panels 80, 85 are travelling within the recess 145 formed by rigid side panels 130, 135 and connecting inner wall 147 of sprayer housing 25. Cradle arms 150, 155 define respective rigid projections extending from wall
35 147 of the sprayer housing 25 into the recess 145 region between the rigid sidewalls 130, 135, and are spaced apart from the rigid sidewalls 130, 135 to define respective slots 160, 165. (A cradle arm is also illustrated in Fig. 9.)

In Fig. 8a the respective ends 161, 166 of trigger wall
40 panels 60, 65 are shown entering respective slots 160, 165

defined by bilateral cradle arms 150, 155.

It is at this point that it is important, for high speed machine assembly, for example, that the spaced-apart dimension of the ends 161, 166 be accurate to match the spaced-apart dimension of respective slots 160, 165, and it is noted that ribs 81, 86 help assure that accuracy at the moment of insertion of the trigger 30 into recess 145 of the sprayer housing 25.

Fig. 8b illustrates the limited inward flexing of the flexible side panel portions 80, 85 as pressure against ramp portions 102, 107 of respective lugs 100, 105 wedge flexible panels 80, 85 inwardly towards each other, thereby allowing the lugs 100, 105 to clear rigid sidewalls 130, 135 and move unharmed between rigid sidewalls 130, 135.

The positioning of the cradle arm, or stop arm elements 150, 155 adjacent sidewalls 130, 135 to define channels or slots 160, 165 to limit the inward flex of the trigger flexible sidewalls 80, 85 is optional.

However, this arrangement of the arms 150, 155 does provide a more positive "snap" when the respective pivot elements 100, 105, and 110, 115 are coaxially aligned and mated, by biasing sidewalls 80, 85 toward the mated position, as shown in Fig. 8c. These cradle arms, in the illustrated position, thereby facilitate achievement of the spaced-apart dimension between flexible panel portions 80, 85, for the ready entry of hinged panel 90 therebetween, after mating of respective lugs 100, 105 with respective sockets 110, 115, for the locking configuration shown in Fig. 8c.

Cradle arms 150, 155 also serve another important function which will be described more fully in connection with the description of Fig. 11; namely, they serve as stop means to prevent the hinging motion of the hinged end panel 90 beyond the proper locking position between flexible panels 80, 85 in the vicinity between pivot lugs 100, 105.

In Fig. 9, the relative position of only one cradle arm 155 is shown for the purpose of simplifying and clarifying the illustration of the positioning of the trigger 30 in pivotally mated position with respect to the sprayer housing 25. The relationships inherent in Fig. 9 are more fully developed immediately hereinafter with the aid of the cross sectional views of Fig. 10 and 11.

As shown in Fig. 10, the hinged end panel 90, and its columnar rib 92 are positioned spaced-apart from the vicinity of the pivot elements, e.g. pivot lug 105, pivot socket 115, and the integral bridge web 125 maintains the hinged end panel 90 in its "open" configuration. Flexible panels 80, 85 can be flexed inwardly towards each other while the hinged, locking end panel 90 is in this position.

Fig. 11 illustrates the configuration prevailing after end panel 90 is moved to a locking position in which the columnar rib 92 is positioned between flexible end walls 80, 85 in the vicinity of the pivot elements, e.g. pivot lugs 100, 105. It is clear from a comparison of Fig. 10 and Fig. 11, that the slots 120 on the respective inner faces of flexible panels 80, 85 of side walls 60, 65 and detentes 180, 185 extending from the respective ends of columnar lock rib 92 serve as a secondary locking arrangement to secure the flexible hinged, locking, end panel 90 in its locking position to provide the primary locking function, namely, keeping flexible panels 80, 85 apart to such an extent that lugs 100, 105 will never leave corresponding respective sockets 110, 115 during operation, or otherwise. The end panel 90 is hinged by the reduced thickness hinge area 125 between the panel 90 and the front panel 75. During assembly or use of the trigger sprayer, cracks will sometimes occur in the hinge area 125. However, with the locking end panel 90 locked in place, such cracks do not adversely affect the trigger 30 or the functioning thereof.

Detentes 180, 185 are also tapered, or "ramped" at 187 to facilitate their entry between panel ends 80, 85, during the locking movement indicated by the arrow c in Fig. 11 and into respective retaining slots 120. The retaining slots 120 serve to lock the detentes 180, 185 in place thereby to lock the end panel 90 in the assembled positions.

Thus, the hinged, locking end panel 90 is shown in its open, unlocked configuration in Figs. 2-10, and is shown in its locked configuration in Figs. 1 and 11.

The role of the cradle arms e.g. 150, namely, preventing overshoot of the flexible, locking end flap 90 beyond the proper locking configuration is clear from Fig. 11.

Hence, attachment of the snap-in lever, or trigger 30 of this invention to a base or sprayer housing 25, in accordance

with this invention, is virtually instantaneous.

Mating of the trigger 30 and the sprayer housing 25 can take place by movement of the trigger 30 into recess 145, from any appropriate direction, e.g. along the lines identified by
5 Arrow A, or Arrow B, in Fig 9.

Positioning of the trigger 30 into the recess 145 approximately as shown in Fig. 9, and moving the trigger relatively towards the sprayer housing 25 along the path indicated by the arrow "A" in Fig. 9, causes the ends 161, 166
10 of trigger side panels to enter slots 160, 165, respectively, and tapered portions 102, 107 of lugs 100, 105 to engage the ends of rigid sidewalls 130, 135. Continued application of pressure in the mating direction results in inward flexing of the trigger side panel portions 80, 85 towards each other. This
15 allows the lugs 100, 105 to easily pass between sidewalls 130, 135 and to be moved easily into a position of coaxial alignment with sockets 110, 115. The lugs 100, 105 then "snap" into sockets 110, 115 to pivotally attach the trigger 30 to the sprayer housing 25. Pushing hinged locking end panel 90 inward,
20 e.g. along the arrow in Fig. 11, results in the locking of the pivot lugs 100, 105 and sockets 110, 115 in the mating, pivoting configuration, and also automatically secures the hinged end panel 90 into that locking configuration.

Hence, this assembly operation can be done almost
25 instantaneously by hand, or by machine.

Operation of this lever system by forcibly moving the unattached end of the trigger 30 towards the sprayer housing 25, brings the rounded portions 101, 106 of the lugs 100, 105 to bear against the opposing rounded bearing surfaces of sockets
30 110, 115 and causes movement of the pump mechanism 50 with mechanical advantage. Hence, providing for truncated portions 102, 107 of pivot lugs 100, 105 doesn't adversely affect the smooth bearing cooperation between the lugs 100, 105, and their corresponding respective sockets 110, 115. Nor does that cause
35 any tendency for the pivot lugs 100, 105 to jump or wedge out of the sockets 110, 115, because it is only the rounded surfaces 101, 106 of the lugs 100, 105 which will bear against the bearing surfaces of sockets 110, 115, during forcible, pivoting operation of the trigger. Note that if desired the truncated
40 ramp surfaces 102, 107 can extend angularly transversely of the

trigger 30 and rearwardly toward the sprayer housing 25 or directly upwardly toward the housing 25 on or at an inclined angle to the vertical, e.g., 45° toward the housing depending on the choice of direction of insertion of the top portion of the trigger 30 into the sprayer housing 25. One preferred direction of insertion is shown by the arrow B in Fig. 7. In this assembly method, the trigger 30 is first located a few millimeters below and in front of the housing 25. Then, the ramp 102, 107 on pivot lugs 100, 105 are moved angularly upwardly past the inside corner of the panels 130, 135 into the recess 147.

In addition, the close abutment of surfaces of the trigger side panels 60, 65 to opposing surfaces of rigid panels 130, 136 of spray head 25, as well as the presence of ends 161, 166 of side panels 60, 65 in slots 160, 165, and the stiffener ribs 81, 86 on side panels 60, 65, all cooperate to prevent wobble or twisting of trigger 25, after assembly, when twisting, or side-to-side forces are applied to the free end of trigger 25, and to reduce the forces applied on pivot lugs 100, 105.

From the foregoing description, it will be apparent that the pivot assembly of the trigger 30 to the sprayer housing 25 provides a number of advantages, some of which have been described herein and others of which are inherent in the assembly. Furthermore, it will be apparent that modifications can be made to the pivot assembly without departing from the teachings of the invention. Accordingly, the scope of the invention is only to be limited as necessitated by the accompanying claims.

CLAIMS

We Claim:

1. A pivot assembly comprising a base and a pivot arm and including pivot means for pivotally attaching said pivot arm
5 to said base; said pivot means including respective mating elements on said base and said pivot arm, said mating elements comprising individual elements of opposing respective mating pairs of bearing sockets and pivot pins; said pivot arm comprising parallel spaced-apart flexible members each carrying
10 one of said respective mating elements, said flexible members being adapted to flex sufficiently to allow said mating elements to enter into mating relationship with their pivot means counterparts on said base without substantial deformation of said mating elements; said pivot arm also comprising an integral
15 hinged member having first locking means, said hinged member being adapted to hinge into a plurality of positions, a first of said positions being in an open configuration in which said first locking element is positioned away from the position of said mating elements, and a second of said positions being in
20 a configuration in which a portion of said first locking means is positioned between said flexible members; said first locking means in said second position being adapted to maintain said mating elements in a mating configuration by restricting said flexible members against relative movement with respect to each
25 other in the vicinity of said mating elements; said pivot arm including second locking means for securing the hinged member in said second position.

2. The assembly of claim 1 including cradle means fixed to said base, and positioned for stopping hinging movement of
30 said hinged member beyond said second position.

3. A pivot assembly comprising a base and a pivot arm and including pivot means for pivotally attaching said pivot arm in a recess in said base; said pivot means including respective mating elements on said pivot arm, and in a recess in said base,
35 said mating elements comprising individual elements of opposing respective mating pairs of bearing sockets and pivot pins; said pivot arm comprising parallel spaced-apart flexible wall members each having leading ends adapted for positioning within said recess and each flexible wall member carrying one of said
40 respective mating elements, said flexible wall members being

adapted to flex toward each other sufficiently to allow said mating elements to enter into mating relationship with their pivot means counterparts in said recess on said base without substantial deformation of said mating elements; said pivot arm
5 also comprising an integral hinged member having first locking means comprising a spacer, said hinged member being adapted to hinge into a plurality of positions, a first of said positions being in an open configuration in which said spacer is positioned away from the position of said mating elements, and
10 a second of said positions being in a configuration in which said spacer is positioned to engage said flexible members; said first locking means in said second of said positions being adapted to maintain said mating elements in a mating configuration by restricting said flexible members against
15 relative movement toward each other in the vicinity of said mating elements; said pivot arm including second locking means for securing the hinged member in said second of said positions.

4. The pivot assembly of claim 3 including cradle means fixed to said base, and positioned for stopping hinging movement
20 of said hinged member beyond said second position.

5. The pivot assembly of claim 4 wherein said cradle means comprises a projection which extends from the base into said recess and which projection is spaced apart from adjacent walls of said recess to define a slot therebetween, said slot being
25 positioned to receive a leading end of a respective one of said flexible wall members as said trigger is being inserted into said recess during assembly, said leading ends being sufficiently long to provide insertion of a respective one of said leading ends into said slot before said pivot means on said
30 trigger encounter opposing surfaces at the entry of said recess, and whereby, when said flexible wall members are flexed closer to each other in order to move corresponding pivot means into mating configuration, the positioning of said leading end in said slot biasing said flexible wall member into the fully
35 spaced-apart position in which the pivot means are properly mated, thereby causing the corresponding pivot means to snap into mating configuration when coaxially aligned, and thereby moving the flexible wall member, when such snap-in occurs, to be positioned sufficiently apart from each other to permit
40 hinging of the locking element in between the flexible wall

members.

6. In a trigger sprayer assembly comprising a sprayer housing and a trigger for controlling the trigger sprayer operation, or for generating pressure to generate a spray operation, said trigger being pivotally mounted in a recess in the sprayer housing by respective mating means comprising opposing mating pairs of bearing sockets and pivot pins in said trigger and in said recess in said sprayer housing, the improvement in which: said trigger includes parallel spaced-apart, flexible wall members each having free ends and each carrying one of said respective mating elements, said flexible wall members being adapted to flex towards each other to allow mating elements on said trigger to enter into mating relationship with pivot means counterparts on said sprayer housing without substantial deformation of any of said mating elements; said trigger also comprising a hinged member having a spacer, said hinged member being adapted to hinge into a plurality of positions, a first of said positions being in a configuration in which said spacer is positioned to allow said parallel opposed flexible members sufficient motion towards each other to enter into a pivotally joined mating position with said spray head base, and a second of said positions being in a closed configuration in which said spacer is positioned between said mating elements; said spacer in second position being adapted to maintain said mating pivot elements in a mating configuration by restraining said flexible members against relative movement towards each other; said trigger including locking means for securing the hinged member in said second position.

7. The trigger sprayer assembly of claim 6 including stop means fixed to said base and positioned for stopping inward movement of said hinged member beyond said second position.

8. The trigger sprayer assembly of claim 7 wherein said stop means comprises a projection which extends from the sprayer housing into said recess and which is spaced apart from adjacent walls of said recess to define a slot, said slot being positioned to receive a leading end of said respective flexible wall member as said trigger is being inserted into said recess during assembly, said leading end being sufficiently long to provide engagement of said leading end in said slot before said

pivot means enter said recess, and whereby, when said flexible wall members are flexed closer to each other in order to move mating pivot means into said recess towards said mating configuration, the positioning of said leading end into said slot bias said flexible wall into the fully spaced-apart position in which the pivot means are properly mated, thereby causing corresponding pivot means to snap into mating configuration when coaxially aligned, and thereby moving the flexible wall member, when such snap-in occurs, to be positioned sufficiently apart from each other to permit hinging of the spacer into a position in between the flexible wall members.

9. The trigger sprayer assembly of claim 6 wherein said opposed inwardly flexible wall members each carry respective coaxial outwardly extending pivot pins adapted to mate with respective coaxial corresponding sockets in a recess of the sprayer housing; said spacer element includes an end post portion which, when said hinged member is in said second position, is coaxial with said pins and sockets, and fits snugly between said opposed flexible wall members.

10. The trigger sprayer assembly of claim 6 wherein said locking means comprises first detente means on said hinged member, which first detente means are positioned to cooperate with corresponding second detente means located on said flexible members.

11. A snap-in trigger for incorporation into a recess in a cooperating base member which has pivot means in said recess for pivotally securing said trigger in said base member, said trigger including: parallel spaced-apart flexible members each having a leading end, and each carrying one mating element for pivotally mating with said pivot means in said base member, said flexible members being adapted to flex inwardly sufficiently to allow entry of the flexible wall members into said recess without deformation of said pivot means, and to allow said mating elements to enter into mating relationship with pivot means counterparts on said base member without substantial deformation of said mating elements or said pivot means; said trigger also comprising an integral hinged member having a spacer element, said hinged member being adapted to hinge into a plurality of positions, a first of said positions being in an open configuration in which said spacer element is positioned

away from the position of said pivot means on said parallel flexible wall members, and a second of said positions being in a closed configuration in which said spacer element is snugly positioned between said flexible members in the vicinity of said mating elements; said spacer in second position being adapted to maintain said mating pivot elements in a mating configuration by restraining said flexible members against relative movement toward each other in the vicinity of the mating elements; said trigger including locking means for securing the hinged member in said second position.

12. The trigger of claim 11 including cradle means fixed to said base positioned for stopping inward movement of said hinged member beyond said second position.

13. The trigger of claim 11 wherein said locking means comprises first detente means on said hinged member, which detente means cooperate with corresponding second detente means on said flexible members.

14. The trigger of claim 11 wherein said opposed inwardly flexible members each carry respective coaxial outwardly extending pivot pins; said spacer element includes a columnar portion which, when said hinged member is in said second position, is coaxial with said pins and fits snugly between said opposed flexible members.

15. A trigger for quick snap-in assembly attachment into a trigger sprayer housing, which sprayer housing has a recess, and pivot means in said recess for pivotally securing said trigger to said sprayer housing in said recess, said trigger comprising: parallel spaced-apart inwardly flexible wall members each having a leading end, and each carrying one mating element for pivotally mating with respective pivot means in said sprayer housing, said flexible wall members being adapted to flex towards each other sufficiently to allow said mating elements to enter into said recess without deforming said mating elements, and to move into a position for mating relationship with pivot means counterparts in said recess without substantial deformation of said mating elements or said pivot means; said trigger also comprising an integral hinged member having a spacer element, said hinged member being adapted to hinge into a plurality of positions, a first of said positions being in an open configuration in which said spacer element is positioned

away from the position of said pivot means on said flexible wall members, and a second of said positions being in a closed configuration in which said spacer element is positioned between said flexible members; said spacer in said second position being
5 adapted to maintain said mating pivot elements in a mating configuration by restraining said flexible members against relative movement toward each other in the vicinity of said mating elements; said trigger including locking means for securing the hinged member in said second position.

10 16. The trigger of claim 15 wherein the mating element includes pivot lugs on each of said flexible wall members, said lugs having a portion thereof truncated to provide a ramp positioned to engage the walls of said recess in said base to forcibly cause the flexible wall members to flex toward each
15 other as the trigger is inserted into said recess.

17. The trigger of claim 15 wherein said inwardly flexible members each carry respective coaxial outwardly extending pivot pins adapted to mate with respective coaxial corresponding sockets in said body portion; said spacer element includes a
20 columnar portion which, when said hinged member is in said second position, is coaxial with said pins and sockets, and fits snugly between said opposed flexible members.

18. The trigger of claim 15 wherein said locking means comprises first detente means on said hinged member, which first
25 detente means cooperate with corresponding second detente means on said flexible members.

19. The trigger of claim 15 wherein said hinged member is an integral molded piece in which said hinged element is manufactured to include an integral, easily frangible bridge
30 maintaining said hinged element in the first, open position.

20. A unitary trigger for quick snap-in assembly attachment into a trigger sprayer housing, which sprayer housing has a recess, and pivot means in said recess for pivotally securing said trigger to said sprayer housing in said recess, said
35 trigger comprising: a unitary element molded from polymer comprising parallel spaced-apart inwardly flexible wall members each having a leading end, and each having one mating element for pivotally mating with respective pivot means in said sprayer housing, said flexible wall members being adapted to flex
40 towards each other sufficiently to allow said mating elements

to enter into said recess without damage to said mating elements, and to move into a position for mating relationship with pivot means counterparts in said recess without damage of said mating elements or said pivot means; said unitary trigger also comprising an integral flexible locking member having a spacer element, said locking member being adapted to move into a plurality of positions, a first of said positions being in an open configuration in which said spacer element is positioned away from the position of said pivot means on said flexible wall members, and a second of said positions being in a closed configuration in which said spacer element is positioned between said flexible members, said spacer in said second position being adapted to maintain said mating pivot elements in a mating configuration by restraining said flexible members against relative movement toward each other in the vicinity of said mating elements; said trigger including second locking means for securing the locking member in said second position.

21. The trigger of claim 20 wherein the mating element includes pivot lugs on each of said flexible wall members, said lugs having a portion thereof truncated to provide a ramp positioned to engage the walls of said recess in said base to forcibly cause the flexible wall members to flex toward each other as the trigger is inserted into said recess.

22. The trigger of claim 20 wherein said inwardly flexible members each carry respective coaxial outwardly extending pivot pins adapted to mate with respective coaxial corresponding sockets in said sprayer housing; said spacer element includes a columnar portion which, when said hinged member is in said second position, is coaxial with said pins and sockets, and fits snugly between said opposed flexible members.

23. The trigger of claim 20 wherein said locking means comprises first detente means on said locking member, which first detente means cooperate with corresponding second detente means on said flexible members.

24. The trigger of claim 20 wherein said hinged member is an integral molded piece in which said locking element is manufactured to include an integral, easily frangible bridge maintaining said locking element in the first, open position.

25. The method of pivotally attaching a trigger to a trigger sprayer housing, said trigger having flexible side panel

portions carrying first pivot mounting means, said sprayer having a recess with second pivot mounting means, said first and second pivot mounting means being adaptable for mating with each other to provide pivotal attachment of said trigger to said sprayer housing, said method comprising the steps: (a) providing on said trigger a flexible spacer element including a locking member, said spacer element being adapted to move said locking member into a plurality of positions, a first of said positions being in an open configuration in which said spacer element is positioned away from the position of said first pivot means on said flexible side panel portions, and a second of said positions being in a closed configuration in which said spacer element is positioned between said flexible side panel portions, said locking member in said second position being adapted to maintain said mating first pivot means in a mating configuration with said second pivot means by restraining said flexible members against relative movement toward each other in the vicinity of said mating elements, said spacer element also comprising secondary lock means for securing said locking element in said second position; (b) inserting said first means into said recess by flexing said flexible side panel portions towards each other, and moving said first pivot mounting means into coaxial alignment with said second mounting means, and mating said first and second pivot mounting means; (c) moving said spacer element to said second position in which said locking element is positioned between said flexible side panel portions; and (d) securing said secondary lock means for securing said locking element in said second position.

26. A trigger for mounting to a trigger sprayer housing having trigger pivot mounting means therein, said trigger comprising an elongate body having a top portion, said top portion including (a) first and second flexible side panels each carrying pivoting structure for mating with the trigger pivot mounting means and (b) flexible, movable locking means for locking said pivot structure in pivotal engagement with the trigger pivot mounting means when said locking means are moved relative to said side panels into a locking position.

27. A pivot assembly in a trigger sprayer comprising a trigger having an elongate body and a top portion and a sprayer

housing having a recess, said assembly comprising trigger pivot mounting means in said recess and said top portion of said trigger body including (a) first and second flexible side panels each carrying pivoting structure for mating with the trigger pivot mounting means and (b) flexible, movable locking means for locking said pivot structure in pivotal engagement with the trigger pivot mounting means when said locking means are moved relative to said side panels into a locking position.

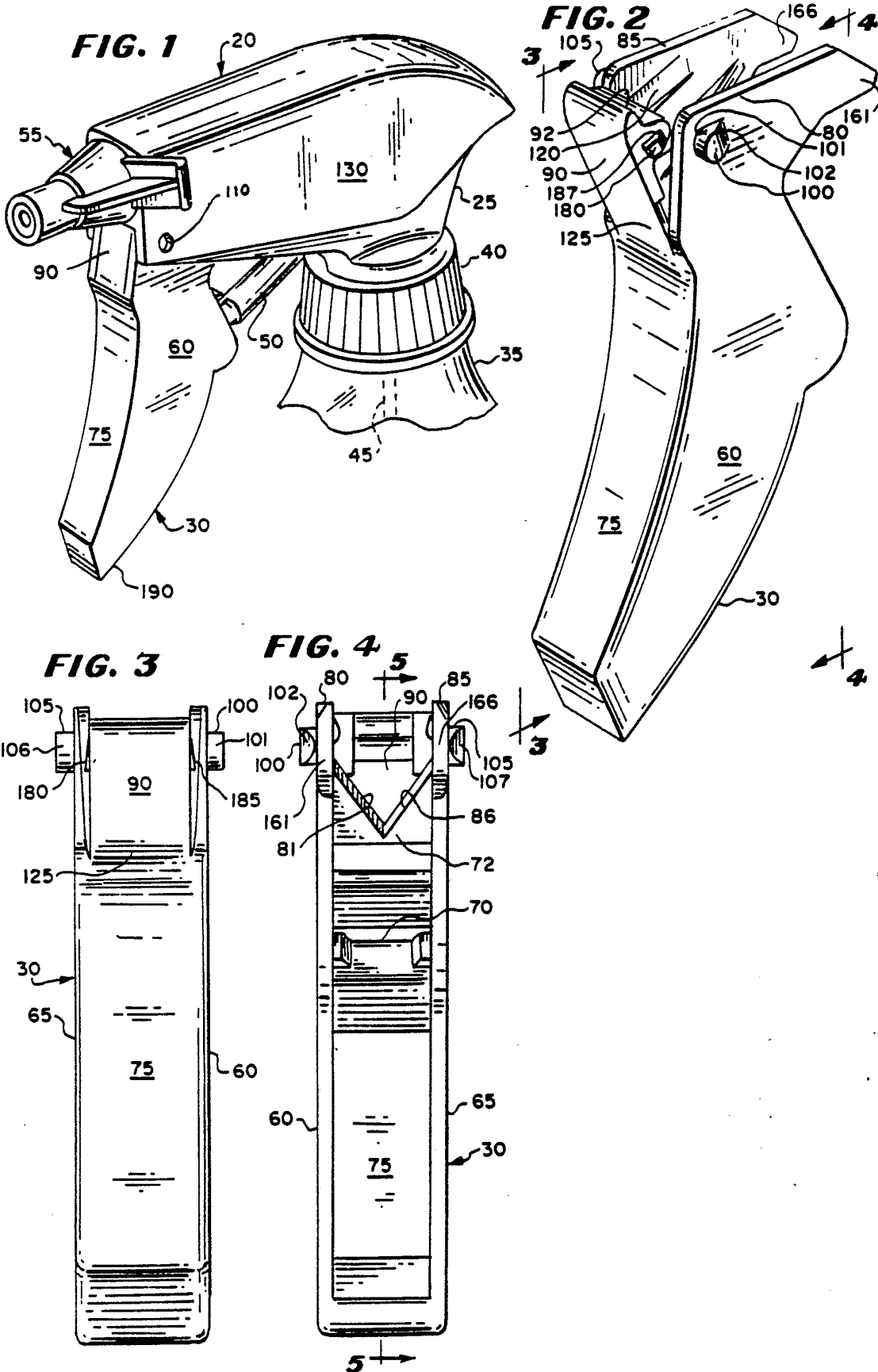

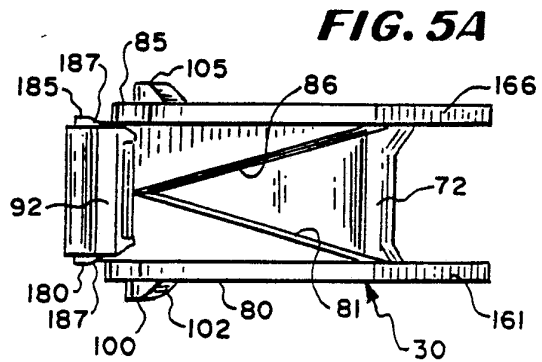
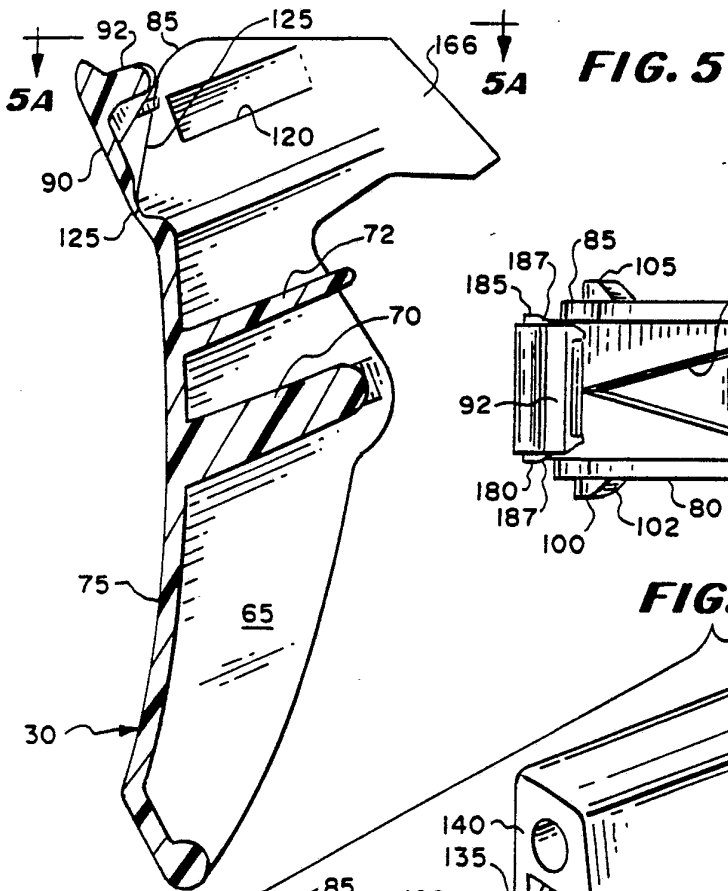

FIG. 6

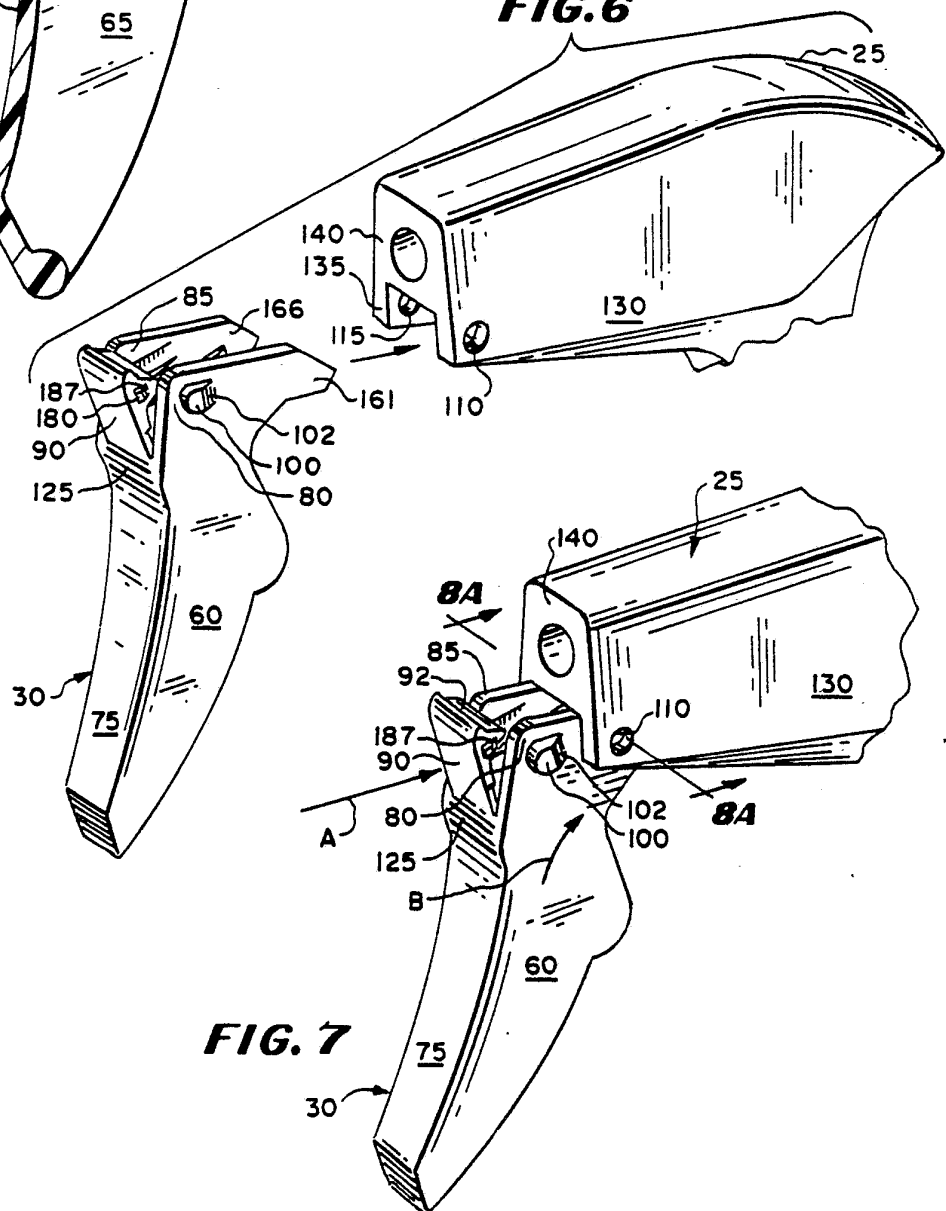
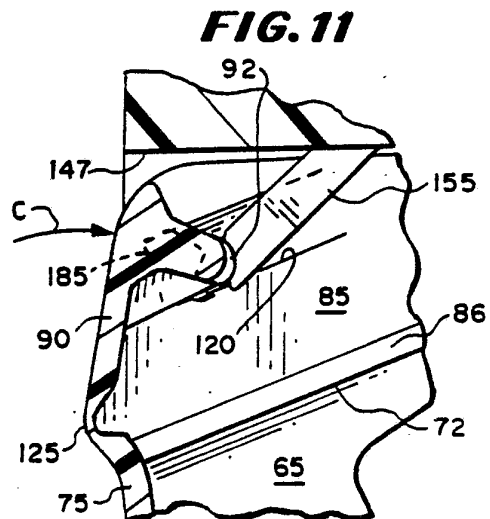
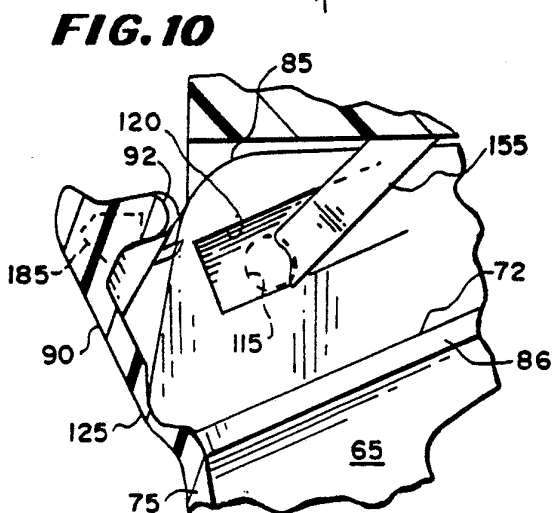
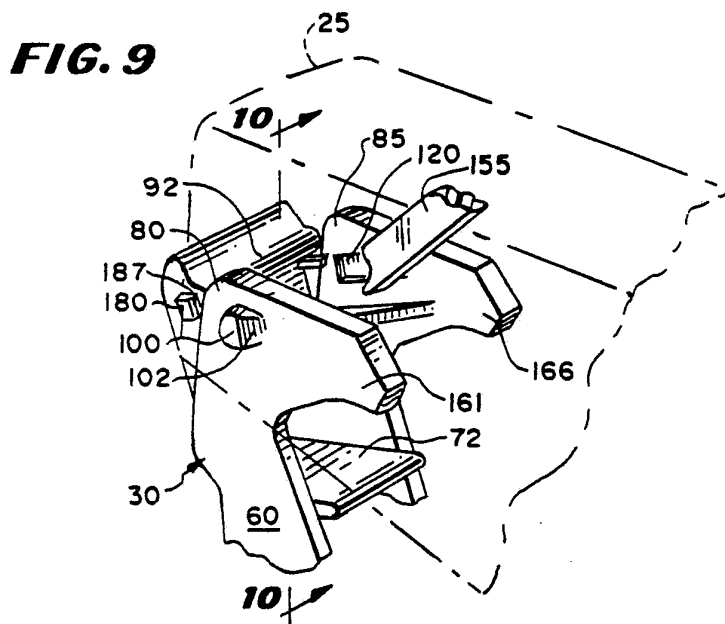
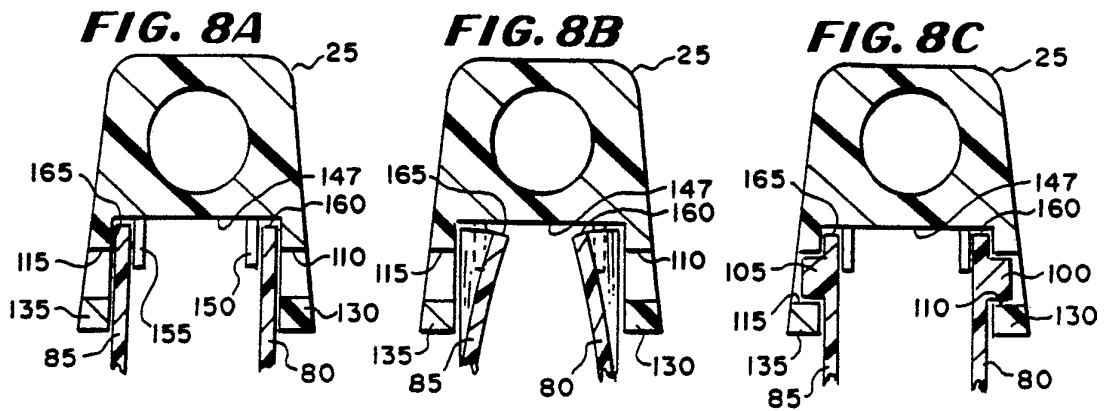

FIG. 7



INTERNATIONAL SEARCH REPORT

International Application No. PCT/US 89/04103

I. CLASSIFICATION OF SUBJECT MATTER (if several classification symbols apply, indicate all) ⁶		
According to International Patent Classification (IPC) or to both National Classification and IPC		
IPC ⁵ : B 05 B 11/00, G 05 G 1/04		
II. FIELDS SEARCHED		
Minimum Documentation Searched ⁷		
Classification System	Classification Symbols	
IPC ⁵	B 05 B, B 65 D	
Documentation Searched other than Minimum Documentation to the Extent that such Documents are Included in the Fields Searched ⁸		
III. DOCUMENTS CONSIDERED TO BE RELEVANT ⁹		
Category ¹⁰	Citation of Document, ¹¹ with indication, where appropriate, of the relevant passages ¹²	Relevant to Claim No. ¹³
A	US, A, 4153203 (TADA) 8 May 1979, see column 5, lines 15-41; figures 2A, 2B (cited in the application)	1, 3, 6, 11, 15, 20, 25-27
A	US, A, 4503998 (MARTIN) 12 March 1985, see column 4, line 53 - column 5, line 19; figures 6, 10-12 (cited in the application)	1, 3, 6, 11, 15, 16, 20, 21, 25-27

<p>¹⁰ Special categories of cited documents: ¹⁰</p> <p>"A" document defining the general state of the art which is not considered to be of particular relevance</p> <p>"E" earlier document but published on or after the international filing date</p> <p>"L" document which may throw doubts on priority claim(s) or which is cited to establish the publication date of another citation or other special reason (as specified)</p> <p>"O" document referring to an oral disclosure, use, exhibition or other means</p> <p>"P" document published prior to the international filing date but later than the priority date claimed</p> <p>"T" later document published after the international filing date or priority date and not in conflict with the application but cited to understand the principle or theory underlying the invention</p> <p>"X" document of particular relevance; the claimed invention cannot be considered novel or cannot be considered to involve an inventive step</p> <p>"Y" document of particular relevance; the claimed invention cannot be considered to involve an inventive step when the document is combined with one or more other such documents, such combination being obvious to a person skilled in the art.</p> <p>"A" document member of the same patent family</p>		
IV. CERTIFICATION		
Date of the Actual Completion of the International Search	Date of Mailing of this International Search Report	
8th December 1989	06 FEB. 1990	
International Searching Authority	Signature of Authorized Officer	
EUROPEAN PATENT OFFICE	G.D. v.d. Vliet	

**ANNEX TO THE INTERNATIONAL SEARCH REPORT
ON INTERNATIONAL PATENT APPLICATION NO.**

US 8904103
SA 31315

This annex lists the patent family members relating to the patent documents cited in the above-mentioned international search report. The members are as contained in the European Patent Office EDP file on 26/01/90. The European Patent Office is in no way liable for these particulars which are merely given for the purpose of information.

Patent document cited in search report	Publication date	Patent family member(s)	Publication date
US-A- 4153203	08-05-79	JP-A- 53107710	20-09-78
		AU-B- 513452	04-12-80
		AU-A- 2963277	26-04-79
		CA-A- 1060397	14-08-79
		DE-A, B, C 2746517	07-09-78
		DE-C- 2759593	08-08-85
		DE-C- 2759594	27-05-87
		FR-A, B 2382274	29-09-78
		GB-A- 1565125	16-04-80
		NL-A- 7711345	05-09-78
		NL-A- 8004830	28-11-80
		NL-A- 8004831	28-11-80
		US-A- 4815663	28-03-89
		US-A- 4230277	28-10-80
US-A- 4503998	12-03-85	US-A- 4480768	06-11-84
		AU-B- 575019	21-07-88
		AU-A- 1647283	12-01-84
		CA-A- 1209542	12-08-86
		EP-A, B 0098508	18-01-84

EPO FORM P0479

For more details about this annex : see Official Journal of the European Patent Office, No. 12/82