

(Model.)

3 Sheets—Sheet 1.

E. STOCKWELL  
PERMUTATION LOCK.

No. 261,271.

Patented July 18, 1882.

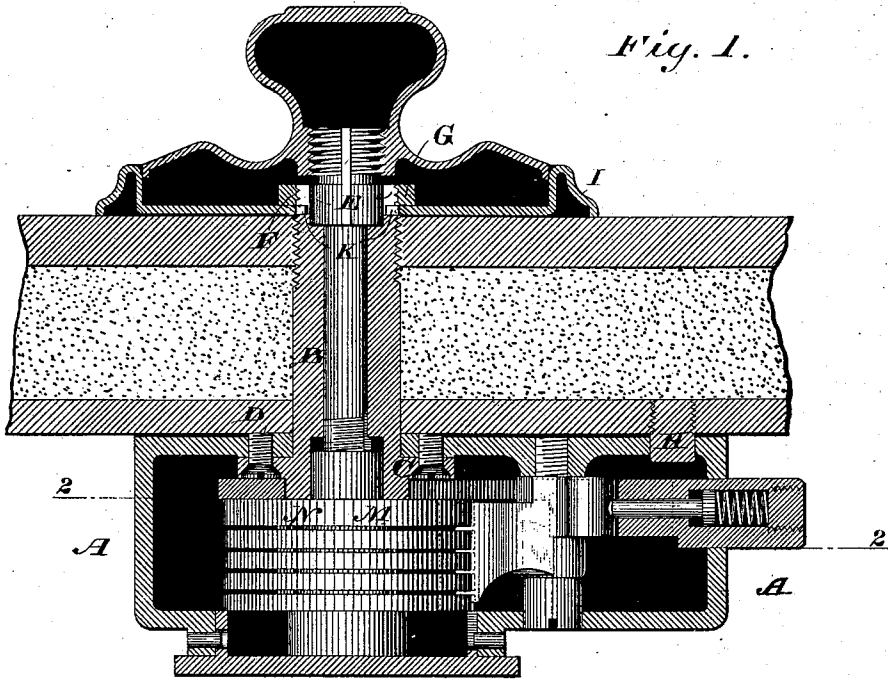
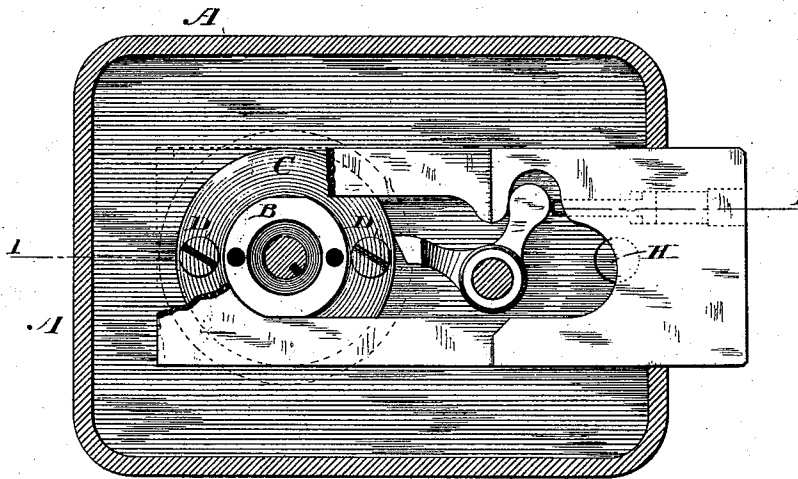

Fig. 2.



WITNESSES

*Wm. A. Skinkb.*  
*Chauncey N. Dutton.*

INVENTOR

*Emory Stockwell*

By his Attorneys,

*Baldwin, Hopkins, & Peyton.*

(Model.)

3 Sheets—Sheet 2.

E. STOCKWELL.  
PERMUTATION LOCK.

No. 261,271.

Patented July 18, 1882.

Fig. 3.

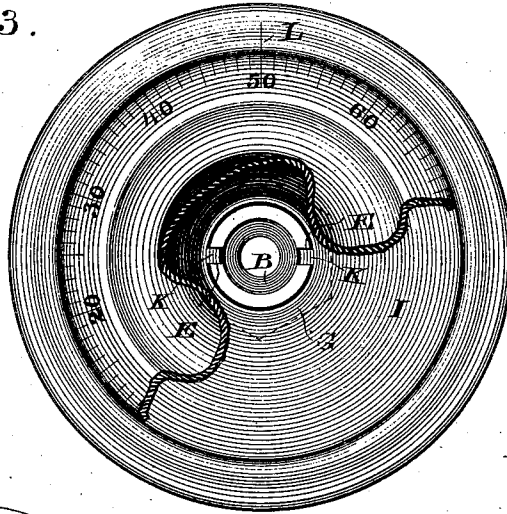

Fig. 4.

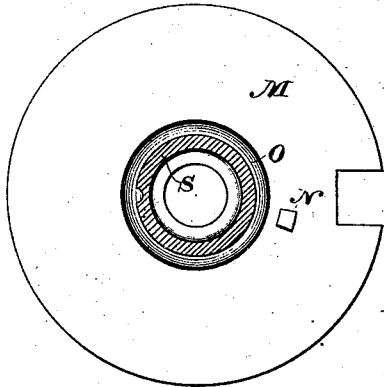

Fig. 5.

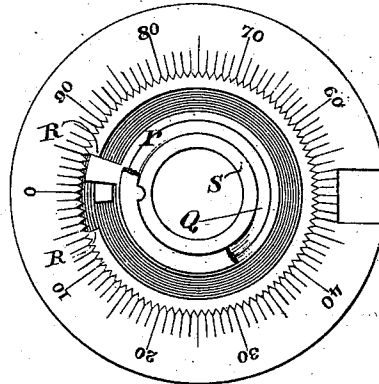
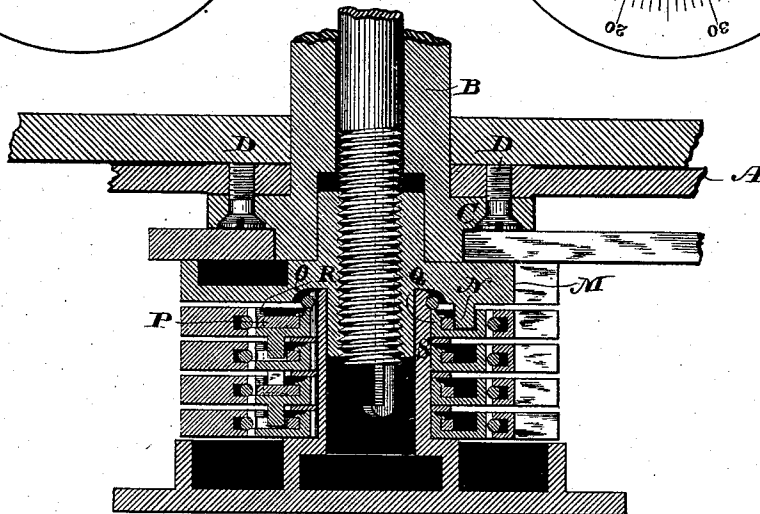

Fig. 6.



WITNESSES

*Wm A. Shink.*  
*Chauncey T. Dutton.*

INVENTOR

*Emory Stockwell*

By his Attorneys.

*William Hopkins, Peyton.*

(Model.)

3 Sheets—Sheet 3.

E. STOCKWELL.

PERMUTATION LOCK.

No. 261,271.

Patented July 18, 1882.

*Fig. 7,*

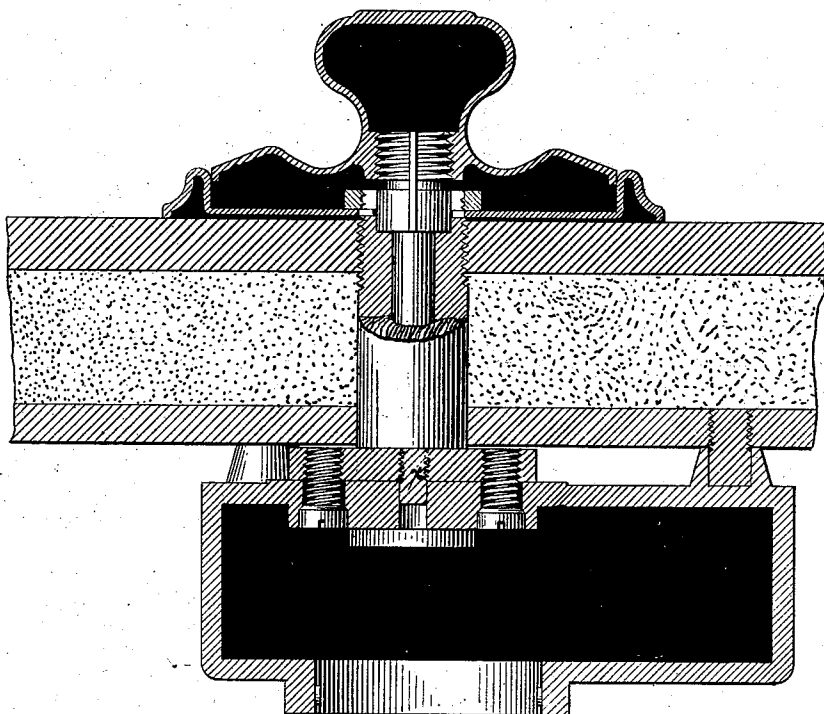

*Fig. 8,*

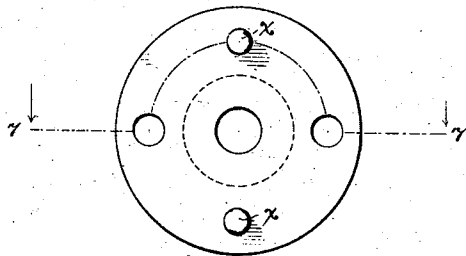

WITNESSES

*Wm. A. Sprinkle*  
*Chauncey T. Dutton.*

INVENTOR

*Emory Stockwell,*

By his Attorneys

*Baldwin, Hopkins, & Peyton.*

# UNITED STATES PATENT OFFICE.

EMORY STOCKWELL, OF STAMFORD, CONNECTICUT, ASSIGNOR TO THE YALE  
LOCK MANUFACTURING COMPANY, OF SAME PLACE.

## PERMUTATION-LOCK.

SPECIFICATION forming part of Letters Patent No. 261,271, dated July 18, 1882.

Application filed February 6, 1882. (Model.)

To all whom it may concern:

Be it known that I, EMORY STOCKWELL, of Stamford, in the county of Fairfield and State of Connecticut, have invented certain new and useful Improvements in Combination Dial-Locks, of which the following is a specification.

My improvements are succinctly specified in my claims.

In the accompanying drawings, illustrating my improvements, Figure 1 is a central section of a dial-lock applied to a door. Fig. 2 is a section on line 2 2 of Fig. 1. Fig. 3 is a view of a dial-ring and dial, partly in section. Fig. 4 is a top view of a cam for operating the tumblers. Fig. 5 is a view of a tumbler. Fig. 6 is a central section through the tumbler mechanism. Fig. 7 is a sectional view on the line 7 7 of Fig. 8, showing a modification in the form of the sleeve; and Fig. 8 is a plan view of the flange of the sleeve, showing the places of the guide-pins and holding-screws.

Referring to the letters on the drawings, A indicates the lock-case, which is cast complete, including front and back, in one piece without seam, instead of being made in separate parts. The advantages of such a cast case are not only its improved appearance, but its greater strength, economy of manufacture, and convenience in use, as it dispenses with the necessity of screws and screw-holes to be provided and used to fasten on the front or back plate. It is, however, not claimed in this patent, but reserved for future claim.

B indicates a spindle-sleeve having a flange, C, upon its inner end, through which screws D pass to secure it firmly to the case when in place. The sleeve is screw-threaded and notched, as at E, on its outer end, and is placed within the lock-case so as to project out through the back portion of the case, and is screwed into the door. The screw-thread is trimmed down somewhat at the extreme outer end, as shown at F, so that the dial-ring may be slipped over the sleeve and held in a concentric position with reference to the dial. The nut G is then turned onto the trimmed thread on the outer extremity of the sleeve, and secures the dial-ring, when the spindle can be screwed into place as usual. The screws D, inserted through the flange C, prevent the

tube from being unscrewed, and a pin, H, projecting from the inside of the door, enters a hole in the lock-case and prevents it from being turned. This pin and the screws take the place of the usual four corner-bolts, and afford a simpler and better means of attaching the lock, as the safe-maker is not required to do any drilling or tapping for the corner-bolts. Should an attempt be made to drive the lock from the door, the strain will be received upon the outer end of the sleeve, which is very strongly connected to the door by a heavy thread. This being so, it is only necessary to secure the lock against turning, as described, by the pin H and sleeve B. The sleeve can be made of any suitable length to accommodate different thicknesses of doors.

I indicates a dial-ring, which has two projecting lugs, K, in its central sleeve-opening, so that the ring may be fitted over the end of the sleeve and the lugs enter the sleeve-notches E. The object of this is to insure the placing of the ring always in proper relation to the sleeve and tumblers, so that the index-mark L on the edge of the ring, by which the combination is worked, can never be set wrong.

In the manufacture of dial-locks it is very desirable that the lock should be so constructed that no mistake can arise in placing the lock on the door or other place where it is desired to use it. Inasmuch as all the operations of the lock are controlled by the index-mark on the dial-ring, it is very essential that this mark should always bear a definite relation to the sleeve and to the case of the lock and to the cam which actuates the tumblers. The construction above set forth necessitates always a fixed relation between the ring, the sleeve, and the case, because the sleeve is fixed in a definite relation to the case by means of the screws D, and the ring in a definite relation to the sleeve by means of the lugs K. Now, the lock being properly put together at the factory, the safe-maker or other person attaching the lock cannot put it together except in a certain definite relation; and if he should tilt the case a little in fastening it to the door the ring will be tilted correspondingly, so that no trouble can possibly arise in operating the lock.

M indicates the usual cam, the revolutions

of which cause the tumblers to revolve by means of the pin or stud N. It is provided with an annular groove, O, in which the tumbler-hub rests, which enables the cam-pin N to be as short as the tumbler-pins.

P indicates the fly which is placed upon each tumbler, and against which the pin of the cam and the pin of each tumbler act. This fly has sufficient motion with reference to the tumbler on which it is placed to allow the tumbler which is next it to revolve an entire revolution before causing the tumbler to which the fly is attached to move.

My improvement consists in giving the fly a central bearing around an annular projection, Q, on the interior of the tumbler, and in having it strike or bear against stops or shoulders R of the outer rim of the inner disk of the tumbler. Thus the fly has a firm bearing at each end, the point of contact of the tumbler-pin with the fly being between these bearings. This holds the fly securely and prevents it from getting bent by any strain upon it so as to interfere with the working of the lock.

The portions of the lock represented in the drawings not described or not claimed are of usual construction, now well understood.

In Fig. 7 I have shown a sleeve adapted to be attached to the outside of the lock case in the same manner that the sleeve shown in Fig. 1 is attached to the inside of the lock-case. The advantage of this form of sleeve is that it can be inserted in place in a door at any time and the lock afterward applied by simply slipping it onto the centering or guide pins *x*, and screwing the screws through the case into the screw-holes of the flange of the sleeve. This I have found to be a convenient mode of connecting the sleeve and case, and the guide-pins at once assure the proper relations of the sleeve and the lock-case.

Having thus described my improvements, what I claim to be new, and desire to secure by Letters Patent, is—

1. In a combination-lock, the combination

of a spindle-sleeve, B, screw-threaded at its outer end for attachment to the door, and provided at its inner end with a flange, and adapted to be applied to a door, with a lock secured to said flange and thereby held in place, substantially as set forth.

2. The combination of a dial-ring provided with lugs and a sleeve provided with notches for fastening them together, substantially as set forth, whereby they can only have a certain fixed relation to each other, for the purpose specified.

3. The combination of a dial-ring and a sleeve, constructed and fastened together substantially as set forth, with a lock-case, whereby these three parts can only be fastened together in a certain fixed relation to each other, for the purpose specified.

4. The combination of a dial-ring, a sleeve, a lock-case, a dial, a spindle, and a cam constructed and fastened together substantially as set forth, whereby they can only have a certain fixed relation to each other, for the purpose specified.

5. The combination, with a lock-case, of a spindle-sleeve, screw-threaded at its outer end for attachment to the door, and provided at its inner end with a flange and with centering or guide pins, whereby the lock-case can be connected to the sleeve only in a certain fixed relation, substantially as and for the purpose specified.

6. A tumbler for a combination-lock, provided with a movable fly, P, said fly turning on an annular projection, Q, and having a stop outside of the track of the driving-pin of the adjacent tumbler-cam, substantially as specified.

7. The combination of a lock-case, a screw-threaded and flanged sleeve for attaching it to a door, and the pin H, to prevent rotation of said case, substantially as specified.

EMORY STOCKWELL.

Witnesses:

SCHUYLER MERRITT,  
GEO. E. WHITE.