

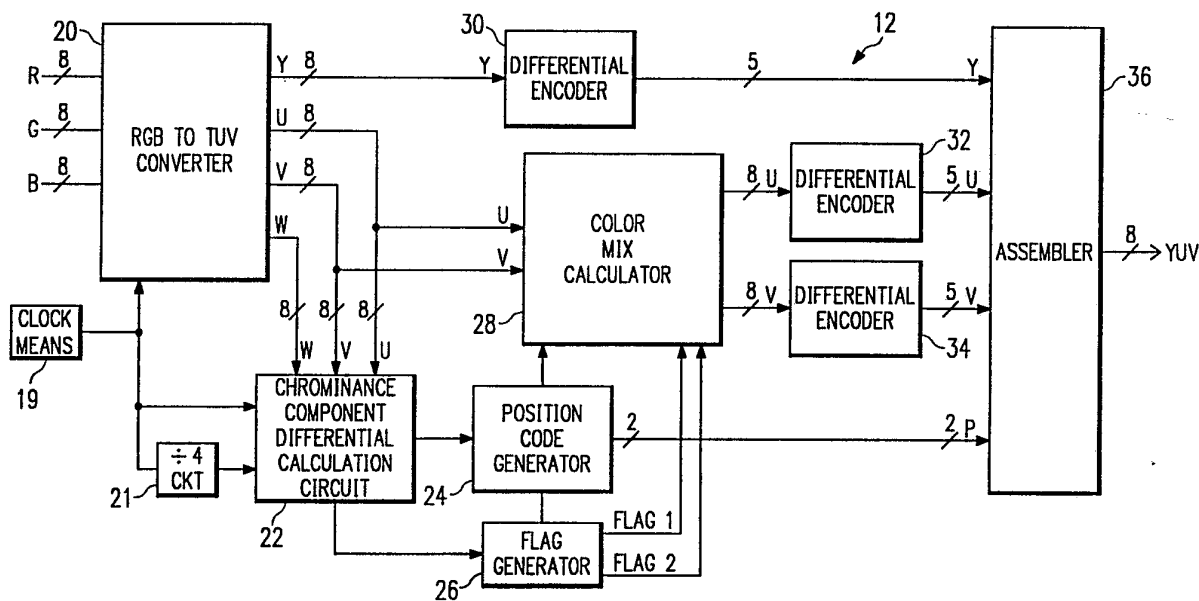

INTERNATIONAL APPLICATION PUBLISHED UNDER THE PATENT COOPERATION TREATY (PCT)

(51) International Patent Classification ⁵ : H04N 11/04, 7/13	A1	(11) International Publication Number: WO 93/07719 (43) International Publication Date: 15 April 1993 (15.04.93)
(21) International Application Number: PCT/US92/07424 (22) International Filing Date: 31 August 1992 (31.08.92) (30) Priority data: 770,544 2 October 1991 (02.10.91) US (71) Applicant: TANDY CORPORATION [US/US]; 1800 One Tandy Center, P.O. Box 171800, Fort Worth, TX 76102 (US). (72) Inventor: WAKELAND, Carl, K. ; 2220 Village Circle, #1212, Bedford, TX 76022 (US). (74) Agents: McCOMBS, David, L. et al.; Haynes and Boone, L.L.P., 3100 NationsBank Plaza, 901 Main Street, Dallas, TX 75202-3789 (US).		(81) Designated States: AT, AU, BB, BG, BR, CA, CH, CS, DE, DK, ES, FI, GB, HU, JP, KP, KR, LK, LU, MG, MN, MW, NL, NO, PL, RO, RU, SD, SE, European patent (AT, BE, CH, DE, DK, ES, FR, GB, GR, IE, IT, LU, MC, NL, SE), OAPI patent (BF, BJ, CF, CG, CI, CM, GA, GN, ML, MR, SN, TD, TG). Published <i>With international search report.</i>

(54) Title: METHOD AND APPARATUS FOR ENCODING FULL COLOR VIDEO DATA AND PROTOCOL FOR ENCODING SAME

**(57) Abstract**

Method and apparatus (12) for encoding full color video data signals and a protocol for encoding the same in a storage medium. Each pixel of a full color video image is converted (20) into a single 8 bit luminance and multiple 8 bit chrominance components. The 8 bit luminance component is differentially compressed (30) into 5 bits while the chrominance components are subsampled (22) for every four pixels of the video image before being differentially compressed. The differentially compressed subsampled chrominance components and the differentially compressed luminance components are then assembled (36) into a video data signal related to the full color image.

FOR THE PURPOSES OF INFORMATION ONLY

Codes used to identify States party to the PCT on the front pages of pamphlets publishing international applications under the PCT.

AT	Austria	FR	France	MR	Mauritania
AU	Australia	GA	Gabon	MW	Malawi
BB	Barbados	GB	United Kingdom	NL	Netherlands
BE	Belgium	GN	Guinea	NO	Norway
BF	Burkina Faso	GR	Greece	NZ	New Zealand
BG	Bulgaria	HU	Hungary	PL	Poland
BJ	Benin	IE	Ireland	PT	Portugal
BR	Brazil	IT	Italy	RO	Romania
CA	Canada	JP	Japan	RU	Russian Federation
CF	Central African Republic	KP	Democratic People's Republic of Korea	SD	Sudan
CG	Congo	KR	Republic of Korea	SE	Sweden
CH	Switzerland	LJ	Licchtenstein	SK	Slovak Republic
CI	Côte d'Ivoire	LK	Sri Lanka	SN	Senegal
CM	Cameroon	LU	Luxembourg	SU	Soviet Union
CS	Czechoslovakia	MC	Monaco	TD	Chad
CZ	Czech Republic	MG	Madagascar	TG	Togo
DE	Germany	ML	Mali	UA	Ukraine
DK	Denmark	MN	Mongolia	US	United States of America
ES	Spain			VN	Viet Nam
FI	Finland				

METHOD AND APPARATUS FOR ENCODING FULL COLOR
VIDEO DATA AND PROTOCOL FOR ENCODING SAME

BACKGROUND OF THE INVENTION

Field of the Invention

5 This invention is related to video signal processing techniques and, more particularly, to a method and apparatus for encoding video color data signals.

Description of Related Art

10 The capability of displaying full-color, 24-bit images on high-resolution monitors has, in recent years, become increasingly in demand, particularly in multimedia and scientific visualization applications. However, full-color, 24-bit images require enormous amounts of storage space which, in turn, increases the cost of such
15 imaging systems considerably. For example, a single full-color, 24-bit image on a high resolution display can often require as much as 3-4 Mbytes of data. In contrast, a single gray-scale image typically requires 1 Mbytes of data and a single black-and-white image typically requires
20 only 125 Kbytes of data. These storage requirements are particularly problematic in animated graphic and/or full motion video applications. Animated graphic applications require the storage and display of hundreds of screen images in sequence. Full-motion color video applications,
25 on the other hand, requires the display of 30 frames, each

- 2 -

demanding approximately 1 Mbyte of storage space, per second. Thus, one minute of full motion color video will require a storage capacity of almost 2 Gigabytes.

Even assuming that sufficient storage capacity is
5 available, data transfer rates pose yet another obstacle to widespread use of full color video imaging systems. Most desktop computers fall well short of the 30 Mbps data transfer rate required for full-motion color video applications. For example, the hard disk drives commonly
10 found in many desktop computers have data transfer rates of 1 to 2 MBps. Furthermore, the data buses most commonly associated with such computer systems also tend to transfer data at rates under 20 MBps. For example, the AT bus drive runs at 8 MBps.

15 The CD has long been viewed as the solution to the storage requirements for full-motion color video applications. CD-ROM drives, however, tend to transfer data at rates slower than hard disk drives. Thus, while the much larger storage space of the CD is capable of
20 addressing one problem with full-motion color video applications, the relatively slow CD-ROM drive remains an obstacle.

The solution to these problems is the use of data compression to reduce the size of the data required to
25 represent a graphic image. In the past, data compression has been widely used for archiving and transmitting text files and various data compression algorithms have been designed for this purpose. The use of compression techniques for image data, on the other hand, have been
30 less frequent. For compressing either text or image data file, the principle is the same - reduce the data to an abbreviated or shorthand form that retains the basic information contained in the file. Often, data compression involves identifying redundant or unnecessary
35 information and substituting an abbreviation or shorthand symbol for that information.

The basic component of an image is the pixel and most image compression techniques address the visual attributes

- 3 -

(color and transparency) attached to each pixel of an image. Because images generally have regions of uniform color or pattern, most commonly in the background, it is possible to represent the visual attributes of these regions using much less data information than that required to separately represent each individual pixel in that region. For this reason, many image compression schemes are directed towards dividing an image into various regions for individually encoding the visual attributes of the regions. For example, in U.S. 4,785,349 to Keith et al., each image is divided into a plurality of coded regions, each being encoded by a region descriptive code conveying data representative of the size and location of the regions within the image and a region fill code conveying pixel amplitude information for the regions. The region descriptive codes and fill codes are grouped together according to type and are variable length encoded according to their statistical distributions in a data stream. Separate variable length decoding of individual segments of the data stream is performed by multiple variable length decoders responsive to statistical information in the stream. Similarly, U.S. 4,868,653 to Golin et al. divides a frame of a digital video signal into a plurality of regions, each of which is separately analyzed and encoded by a selected one of several compression procedures to provide an optimum coding specific to the characteristics of the region being coded.

It has often been recognized that, in generating a high quality image, certain components of the data information for the image are less important than the data information of other components of the image. One way that this concept has been exploited has been to add additional information to full color video signals. For example, U.S. 5,300,377 to Lipmann et al. discloses an extended definition television system which generated chrominance data information at a fraction of the frame rate and using the additional channel space for encoded

- 4 -

additional luminance data information. Similarly, many image compression schemes are also based upon the concept that, in maintaining a high quality image, certain types of data information are less important than other types of data information. In an extreme case, it is sometimes possible to discard portions of the data information altogether when compressing an image without negatively impacting the quality of the image. For example, some of the data information may be related to a portion of the image not visible to the human eye and may, therefore, be readily discarded. In other, less extreme cases, image compression schemes selectively compress various components of the image. For example, U.S. 4,953,196 to Ishikawa et al. discloses a compression method used for transmitting color video images over phone lines. Here, a digital RGB signal is converted into a luminance (or "Y") signal and a pair of color difference signals referred to as "I" and "Q" signals. Differential pulse code modulation (or "DPCM") is used to compress and encode the Y signal and, taking into account the visual characteristics of the I and Q signals, the color difference signals are thinned out by selectively discarding certain color difference signals.

Another data information compression scheme utilizes a 4:2:2 YUV compression ratio during the encoding process. The Y (or "luminance") signal is encoded in 8 bits per pixel. Before encoding the U ("blue-green axis") and V ("red-green axis") signals in 8 bits per pixel as well, the U and V signals are low-pass filtered and subsampled so that the encoded signal represents the chrominance values averaged over two pixels. A similar data information compression scheme also subsamples the U and V signals at a 2:1 ratio but encodes each of the Y, subsampled U and subsampled V signals in 4 bits per pixel value in four bits, also subsampling the U and V values at a 2:1 ratio.

- 5 -

SUMMARY OF THE INVENTION

In one embodiment, the present invention is of a method for encoding video data relating to a full color image. Each pixel of a full color video image is converted into single 8 bit luminance and multiple 8 bit twos-complement chrominance components. The 8 bit luminance component is differentially compressed into 5 bits while the chrominance components are subsampled for every four pixels of the video image before being differentially compressed. The differentially compressed subsampled chrominance components and the differentially compressed luminance components are then assembled into a video data signal related to the full color image. In one aspect of this embodiment of the invention, the differentially compressed components are adjusted based upon a comparison between running sums of the original difference values and restored compressed difference values. In another aspect of this embodiment of the invention, the position of a principal color transition is identified from the chrominance components of the full color image and appended to the assembled video data signal.

In another embodiment, the present invention is of an apparatus for encoding a full color video image comprised of a plurality of pixel elements. The video image encoder includes means for converting each pixel element of the full color video image into 8 bit luminance and 8 bit twos-complement chrominance components, means for subsampling the chrominance components of the pixel elements, means for differentially compressing the luminance components and the subsampled chrominance components and a multiplexing means for assembling an encoded video data signal from the differentially compressed luminance components and the differentially compressed subsampled chrominance components. In other aspects of this embodiment of the invention, the differentially compressed subsampled chrominance components are determined by calculating chrominance

- 6 -

difference values for every sequence of four pixel elements and compressing the chrominance difference values from 9 bit twos-complement to 5 bits and the differentially compressed luminance components are
5 determined by calculating a 9 bit difference value between luminance components for sequential pixel elements and compressing the difference value from 9 to 5 bits.

In still yet another embodiment, the present invention is of a protocol for encoding video data signals
10 related to a full color image in a storage medium. The protocol includes means for converting video data signals related to color levels for a full color image into luminance and chrominance components, means for differentially compressing the luminance components and
15 subsampled chrominance components, respectively, of the full color image and means for encoding, in a storage medium, a video data signal which includes a first field related to the differentially compressed luminance component, a second field related to the differentially
20 compressed subsampled chrominance component and a third field related to the position of principal color transition for the full color image.

BRIEF DESCRIPTION OF THE DRAWINGS

The present invention may be better understood, and
25 its numerous objects, features and advantages will become apparent to those skilled in the art by reference to the accompanying drawings in which:

FIG. 1 is a block diagram of an image transmission system having a video color encoding system constructed in
30 accordance with the teachings of the present invention;

FIG. 2 is a block diagram of the video color encoding system of FIG. 1;

FIG. 3 is a schematic drawing which illustrates a series of pixels of video data during a subsampling
35 process performed by the video color encoding system of FIG. 2;

- 7 -

FIG. 4 is a block diagram of a differential encoder schematic of a differential encoder included as part of the video color encoding system of FIG. 2; and

FIG. 5 is a schematic drawing which illustrates a series of pixels of video data in color mix combinations relative to the various positions and magnitudes of the principal color transitions.

DETAILED DESCRIPTION OF A PREFERRED EMBODIMENT

Referring first to FIG. 1, an image transmission system having a video color encoding system constructed in accordance with the teachings of the present invention shall now be described in greater detail. In the preferred embodiment, the image transmission system includes an image source 10 for providing a full motion color digital video signal, either from a television broadcast signal, directly coupled video camera or other image source, although it is fully contemplated that, in alternate embodiments of the invention, the image source 10 may provide a still color digital video signal from a still photography system or other image source configured to generate or transmit a color digital video signal. Furthermore, while it is preferred that the image source 10 should provide a color digital video signal, it is also contemplated that the image source 10 may be selected such that an analog video signal shall be provided, in which case, an analog-to-digital converter should be included as part of the image transmission system subject of the present invention.

The image source 10 transmits the full motion color video signal to a color video encoder 12 which, in accordance with the teachings of the present invention, processes the full motion color video signal utilizing a differential compression technique more fully described below which reduces the memory space required to store the full motion color video image, and transmits the processed color video signal to a storage medium 14. For example, the storage medium 14 may be a compact disc read only memory (or "CD-ROM") onto which the processed color video

- 8 -

image is recorded. At any time thereafter, the processed color video image may be retrieved from the storage medium 14 in a form substantially identical to that which it was recorded thereto, for example, using a conventional CD-ROM drive (not shown) and transmitted to a video color decoder 5 16. The video color decoder 16, which is described in detail in co-pending U.S. Patent Application Ser. No. 07/771,310, decompresses the retrieved video color signal to produce a full motion video color signal substantially 10 identical to that originally produced by the image source 10. In turn, the decompressed video color signal is transmitted to display means 20 which may be, for example, a television receiver, computer monitor or other imaging device, for display.

15 Referring next to FIG. 2, the full motion video color encoder 12 shall now be described in greater detail. The encoder 12 receives a video color data signal comprised of a series of signals, each signal having a component corresponding to a digitally encoded level of red, green 20 and blue for a pixel element (or "PEL") of an image. More specifically, each video color data signal is a 24 bit signal comprised of 8 bit red, green and blue components appended in sequence and all corresponding to a single PEL of the image. Clock means 19 sequentially propagates each 25 24 bit video color data signal into an RGB to YUV converter 20 where the digitally encoded red, green and blue levels for a PEL are converted to YUV encoded data information. In this regard, the "Y" component represents the luminance for the PEL, the "U" component represents 30 the difference in luminance versus red for the PEL and is a first chrominance component, the "V" component represents the difference in luminance versus blue for the PEL and is a second chrominance component and the "W" component represents the difference in luminance versus 35 green for the PEL and is a third chrominance components. The RGB to YUV converter 20 converts the RGB levels into the aforementioned luminance and chrominance components in accordance with the following relationships:

$$Y = .0299R + 0.587 + 0.114B \tag{1}$$

$$U = 0.564 (B-Y) \tag{2}$$

$$V = 0.713 (R-Y) \tag{3}$$

$$W = 1.219 (G-Y) \tag{4}$$

5 The determined 8 bit twos-complement U, V and W chrominance components are then propagated to a chrominance component differential calculation circuit 22 where the principal color changes for a sequence of four pixels is determined. For example, if a sequence of four
 10 pixels (PEL = 0, 1, 2, 3) in a series of pixels propagated to the chrominance component differential calculation circuit 22 is as follows:

PEL ... -1 | 0 1 2 3 | 4 5 ...

...	U ₋₁	U ₀	U ₁	U ₂	U ₃	U ₄	U ₅	...
...	V ₋₁	V ₀	V ₁	V ₂	V ₃	V ₄	V ₅	...
...	W ₋₁	W ₀	W ₁	W ₂	W ₃	W ₄	W ₅	...

The differences between the chrominance components U_n, V_n and W_n of a PEL and the chrominance components U_{n-1}, V_{n-1} and W_{n-1} of the previous PEL would then
 20 be determined to be:

	U ₀ - U ₋₁	V ₀ - V ₋₁	W ₀ - W ₋₁
	U ₁ - U ₀	V ₁ - V ₀	W ₁ - W ₀
	U ₂ - U ₁	V ₂ - V ₁	W ₂ - W ₁
	U ₃ - U ₂	V ₃ - V ₂	W ₃ - W ₂
25	U ₄ - U ₃	V ₄ - V ₃	W ₄ - W ₃

If the greatest value from this set of 9 bit twos-complement difference values exceeds a predetermined threshold value selected to prevent the designation of a small color change not visible to the human eye as a color
 30 transition, this value would be designated as the predominant color transition occurring within the selected sequence of four pixels.

Information relating to the predominant color transition occurring within the selected sequence of four
 35 pixels would then be propagated by a divide by 4 clock circuit 21 to a position code generator 24 where a 2 bit position code generator 24 where a 2 bit position code corresponding to the location within the selected four pixel sequence where the predominant transition occurs.

- 10 -

For example, a position code of 0 would be generated by the position code generator 24 if the predominant 9 bit twos-complement difference value occurs between pixels one and two of the 4 pixel sequence. Referring to the previous example, this would occur if the predominant 9 bit twos-complement difference value was either U_1-U_0 , V_1-V_0 , or W_1-W_0 . A position code of 1 would be generated by the position code generator 24 if the predominant 9 bit twos-complement difference value occurs between pixels two and three of the 4 pixel sequence. This would occur if the predominant 9 bit twos-complement difference value was either U_2-U_1 , V_2-V_1 , or W_2-W_1 . A position code of 2 would be generated by the position code generator 24 if the predominant 9 bit twos-complement difference value occurs between pixels three and four of the 4 pixel sequence. This would occur if the predominant 9 bit twos-complement difference value was either U_3-U_2 , V_3-V_2 , or W_3-W_2 . Lastly, a position code of 3 would be generated by the position code generator 24 if the predominant 9 bit twos-complement difference value occurs at the boundary between the 4 pixel sequences, corresponding to the predominant 9 bit twos-complement difference value as either U_4-U_3 , V_4-V_3 , W_4-W_3 , U_0-U_{-1} , V_0-V_{-1} , or W_0-W_{-1} . Position code 3 will also be generated if none of the 9 bit twos-complement difference values is greater than the predetermined threshold value discussed above. Alternatively, the U, V and W differences for each 4-pixel sequence may be summed as follows:

$$T_0 = (U_0 - V_{-1}) + (V_0 - V_{-1}) + (W_0 - W_{-1}); \quad (5)$$

$$T_1 = (U_1 - V_0) + (V_1 - V_0) + (W_1 - W_0); \quad (6)$$

$$T_2 = (U_2 - U_1) + (V_2 - V_1) + (W_2 - W_1); \quad (7)$$

$$T_3 = (U_3 - U_2) + (V_3 - V_2) + (W_3 - W_2); \quad (8)$$

$$T_4 = (U_4 - U_3) + (V_4 - V_3) + (W_4 - W_3); \quad (9)$$

As is schematically illustrated in FIG. 3, the position code of 0 would then be assigned if T_1 is the greatest value in the set T_0, T_1, T_2, T_3, T_4 , and its value exceeds a predetermined threshold level.

- 11 -

Similarly, the position code of 1 is assigned if T_2 is the greatest value in the aforementioned set. The position code 2 is assigned if T_3 is the greatest value in the set, and the position code 3 is assigned if either
5 T_0 or T_4 is the greatest value in the set.

If T_1 is nearly equal or equal to T_2 and both values exceed a pre-determined high threshold, then the position code 1 is assigned. If T_2 is nearly equal to T_3 and both values exceed a pre-determined high
10 threshold, then the position code 2 is assigned. If T_1 , T_2 and T_3 all are nearly equal or equal and all exceed a pre-determined high threshold, then the position code 1 is assigned.

Returning now to FIG. 2, flag generator 26 generates
15 two codes, or "flags", for every 4 pixel sequence. Flag 1 provides an indication as to whether a predominate change in color occurred in the selected 4 pixel sequence which should be transmitted to the next 4 pixel sequence. If no significant color change occurs within a 4 pixel sequence,
20 and position code 3 is generated by the position code generator 24, the flag generator 26 shall set flag 1 to 0. If, on the other hand, a significant color change occurs within a 4-pixel sequence, i.e., either position code 0, 1, or 2 is generated by the position code
25 generator 24, or if a transition value exceeding a pre-determined high threshold occurred at positions T_0 or T_4 , then the flag generator 26 shall set flag 1 to 1. A second flag, designated as Flag 2, is generated by flag generator 26 and is set to 1 if one of the transition
30 difference values T_0 , T_1 , T_2 , T_3 or T_4 is greater than a predetermined limit value. This would occur if a particularly large color change occurs within that four-pixel block. If all of the transition
difference values T_0 , T_1 , T_2 , T_3 and T_4 are
35 below the aforementioned predetermined limit value, then Flag 2 is set to 0.

The flags, position code and the 8 bit twos-complement U and V chrominance values for each PEL in a 4 pixel sequence are then clocked into a color mix calculator 28. The color mix calculator 28 determines the average color values for each four pixel sequence while the U and V chrominance values, the values from the previous 4 pixel sequence and the subsequent 4 pixel sequence are buffered. Referring to FIG. 5, if the position code for a 4 pixel sequence N+1 is either 0, 1, or 2, i.e., a predominant color transition occurs within the sequence and there was no predominant color transition in the previous sequence, then the four pixels of 8 bit twos-complement U and V values preceding the predominant transition are averaged to determine the U_{N+1} and V_{N+1} average color values for the N+1 4 pixel sequence. For example, referring to FIG. 5, for a position code of 2 and flag 1 = 0, the average color values, U_{N+1} and V_{N+1} would be:

$$U_{N+1} = (U_N[3] + U_{N+1}[0] + U_{N+1}[1] + U_{N+1}[2])/4; \quad (10)$$

$$V_{N+1} = (V_N[3] + V_{N+1}[0] + V_{N+1}[1] + V_{N+1}[2])/4. \quad (11)$$

Since a change in color occurred within 4 pixel sequence N+1, flag 1 will be set to 1 to indicate to the next 4 pixel sequence, N+2, that a color transition has occurred in the previous 4 pixel sequence N+1.

If no predominant color transition occurs in the next 4-pixel sequence N+2, then the four pixels following the predominant transition would be sampled to determine the average color values U_{N+2} and V_{N+2} for the subsequent 4-pixel sequence, N+2. Thus, these values would be as follows:

$$U_{N+2} = (U_{N+1}[3] + U_{N+2}[0] + U_{N+2}[1] + U_{N+2}[2])/4; \quad (12)$$

$$V_{N+2} = (V_{N+1}[3] + V_{N+2}[0] + V_{N+2}[1] + V_{N+2}[2])/4. \quad (13)$$

If another predominant color transition occurs in the next 4 pixel sequence, N+2, the process is repeated; however, the color mix calculator 28 will first determine if a predominant color transition occurred in the previous 4-pixel sequence, N+1 based upon flag 1. If flag 1 is set to 1, then a predominant color transition did occur in the

- 13 -

previous 4 pixel sequence, N+1 and, under these conditions, the color mix calculator 28 will not average the color values for the four PEL preceding the transition found in N+2 giving U_{N+2} and V_{N+2} , as this would
5 conflict with the transition already found in the previous sequence, N+1. The color mix calculator 8 will only mix the next four PEL which follow the transition found in the previous sequence to obtain the average color values, U_{N+2} and V_{N+2} , to be assigned to the 4-pixel sequence,
10 N+2. Flag 1 is then reset to 0.

If a predominant color transition had not occurred in the previous 4 pixel sequence N+1, the flag had been set to 0, and the position code for N+2 was 0, 1, or 2, then the color mix calculator 28 will average the color values
15 for the four PEL preceding the transition point found in N+2 to obtain the values U_{N+2} and V_{N+2} .

If a predominant color transition had not occurred in the previous 4 pixel sequence N+1, flag 1 had been set to 0 and the position code has a value of 3 then the color
20 mix calculator 28 will average the four PELs of the 4-pixel sequence to obtain the color values U_{N+2} and V_{N+2} .

Flag 2, which originates in flag generator 26, influences the color mix calculator 28 in the following
25 manner: If flag 2 is set to 1, indicating that a color transition occurred which exceeded a pre-determined high threshold level, and a position code of 0, 1, or 2 was generated for the four-pixel sequence N+1, the average color values U_{N+1} and V_{N+1} will be calculated as
30 already described, with the exception that the pixel nearest to the transition will not be included in the calculation. Similarly, in the color mix calculation for the four-pixel sequence N+2, the pixel nearest to the color transition occurring in sequence N+1 will not be
35 used in the color mix calculation. If no predominant transition which exceeds the predetermined high threshold occurs in sequence N+1, flag 2 will be reset to 0. If, however, a predominant color transition does occur which

- 14 -

exceeds the predetermined high threshold, flag 2 will remain set to 1 through the following four-pixel sequence N+2.

If transition difference value T4, referenced to
 5 four-pixel sequence N+1, exceeds the predetermined high threshold and the assigned position code for the four-pixel sequence N+1 is 3, then the average color values will be calculated in accordance with the following:

$$U_{N+1} = (U_{N+1}[0] + U_{N+1}[1] + U_{N+1}[2]) / 3; \quad (14)$$

$$10 \quad V_{N+1} = (V_{N+1}[0] + V_{N+1}[1] + V_{N+1}[2]) / 3; \quad (15)$$

The mix calculation for the following pixel sequence N+2 will then be calculated in accordance with the following:

$$U_{N+2} = (U_{N+2}[1] + U_{N+2}[2] + U_{N+2}[3]) / 3; \quad (16)$$

$$V_{N+2} = (V_{N+2}[1] + V_{N+2}[2] + V_{N+2}[3]) / 3; \quad (17)$$

15 Referring momentarily to FIG. 5, the shaded areas for the various mix calculation ranges designate those pixels which, as already described, will not be included in the color mix calculations for U_{N+1} and V_{N+1} when Flag 2 is set to 1.

20 Returning now to FIG. 2, the 8 bit Y luminance component is transmitted from the RGB to YUV converter 20 and the subsampled 9 bit twos-complement U and V chrominance components are transmitted from the color mix calculator 28 to differential encoders 30, 32 and 34,
 25 respectively, for differential compression to 5 bit values. Once differentially compressed as five bit values, the Y, U and V components are propagated, along with the two bit position code P generated by the position code generator 24, to an assembler 36 for multiplexing as
 30 a differentially compressed encoded video signal which corresponds to the full color video image.

Referring next to FIG. 4, the differential
 compression of the 8 bit Y, U and V components of the
 signal compressed by the differential encoders 30, 32, 34,
 35 respectively, shall now be described in greater detail. In this regard, it should be clearly understood that the differential compression of the 8 bit Y, U, and V components of the signal are separately performed in

- 15 -

accordance with the below description of the differential compression of a single 8 bit component. As to be more fully described below, a series of 8 bit components are sequentially pipelined through the differential encoder

5 32. A first 8 bit component is supplied to a latch 40, for example a D-type flip-flop, which latches the component and a subtraction unit 42 which processes the component and propagates it through the encoder 30. A next 8 bit component is then supplied to the subtraction

10 unit 42 and the latch 40, which, in turn, propagates the first 8 bit component to the subtraction unit 42 where the difference between the first 8 bit component and the successive 8 bit component is determined.

The 9 bit difference value determined by subtracting

15 the successive 8 bit component from the first 8 bit component is propagated to both a compressor 44 and an adder 52. The compressor 44 compresses the input 9 bit difference value into a 5 bit value. In the preferred embodiment of the invention, the compressor 44 is

20 comprised of a series of software instructions configured to effect actuation of the relational table set forth below although, in an alternate embodiment of the invention, it is contemplated that the compressor 44 may be comprised of a series of combinatorial logic gates

25 designed to effect actuation of the aforementioned relational table.

	<u>9-bit Twos-Complement</u>	<u>5 bit Values</u>
	0	0
	1 or -255	1
30	2 or -254	2
	3 or -253	3
	4 or -252	4
	5 or -251	5
	6...7 or -250...-249	6
35	8...10 or -248...-246	7
	11...14 or -245...-242	8
	15...19 or -241...-237	9
	20...25 or -236...-231	10

- 16 -

	<u>9-bit Twos-Complement</u>	<u>5 bit Values</u>
	26...33 or -230...-223	11
	34...43 or -222...-213	12
	44...56 or -212...-200	13
5	57...76 or -199...-180	14
	77...106 or -179...-150	15
	107...149 or -149...-170	16
	150...179 or -106...77	17
	180...199 or -76...-57	18
10	200...212 or -56...-44	19
	213...222 or -43...-34	20
	223...230 or -33...-26	21
	231...236 or -25...-20	22
	237...241 or -19...-15	23
15	242...245 or -14...-11	24
	246...248 or -10...-8	25
	249...250 or -7...-6	26
	251 or -5	27
	252 or -4	28
20	253 or -3	29
	254 or -2	30
	255 or -1	31

TABLE I

In this manner, the compressor 44 compresses each 9 bit
 25 input value into a binary 5 bit output value. It is
 further contemplated that the particular configuration of
 the relational table is selected such that small color
 differentials between successive signals will be favored,
 i.e. will be more clearly encoded, over large color
 30 differentials between successive signals. In this manner,
 small color transitions that might otherwise be indistinct
 will be clearly imaged. To enhance the capability of
 encoding the smaller color differentials, selected ones of
 the 9 bit differential values are related to specific ones
 35 of the 5 bit differential values in a one to one
 correspondence while relatively large ranges of other 9
 bit differential values are related to a single 5 bit
 differential value. The compressed 5 bit difference value

- 17 -

produced by the compressor 44 is propagated to an expander 46 where the compressed 5 bit difference value is expanded back into a restored 8 bit difference value, using the relational values set forth in Table II.

	<u>5 bit Values</u>	<u>8 bit Values</u>
	0	0
	1	1
	2	2
	3	3
10	4	4
	5	5
	6	6
	7	9
	8	12
15	9	17
	10	22
	11	29
	12	38
	13	50
20	14	66
	15	91
	16	128
	17	165
	18	190
25	19	206
	20	218
	21	227
	22	234
	23	239
30	24	244
	25	247
	26	250
	27	251
	28	252
35	29	253
	30	254
	31	255

- 18 -

TABLE II

For those 5 bit values to which multiple 9 bit difference values corresponded in Table I, Table II selects the average of the multiple positive values corresponding to the previously selected 5 bit value. Unlike the input to the compressor 44, the output of expander 46 utilizes only 8 bits and achieves negative values by using wrap-around when computing the running sum. As before, it is preferred that the expander 46 be comprised of a series of software instructions configured to effect actuation of the inverse of the relational table although, it is again further contemplated that the expander 46 may alternately be comprised of a series of combinatorial logic gates designed to effect actuation of the aforementioned relationships.

The restored 8 bit running sum is then compared to the original 8 bit running sum. More specifically, the original 9 bit difference value and the restored 8 bit difference value are propagated to adders 52, 48, respectively. Respective latches 54, 50, which again may be, for example D-type flip-flops, connected to the output of the adders 52, 48 are used to latch the output of the adders 52, 48 and propagate the output back to the adder 52, 48 for adding with the next original and restored difference values, respectively, thereby producing a running sum for each value. The resulting running sums of the original and restored differences are also propagated by the latches 54, 50 to a comparator 56. The comparator 56 determines the difference between the original 8 bit running sum and the restored 8 bit running sum and, based on the difference between the two, will revise the 5 bit compressed difference value which propagates to expander 46.

More specifically, the comparator 56 will compare the running sum of the original 9 bit difference value and the running sum of the restored 8 bit difference values. If the restored running sum is higher or lower than the original running sum, the comparator will send a signal to

- 19 -

the expander 44 to adjust the compression and expansion relationships so that later running sums will be closer in value than the compared running sums. For example, if the restored running sum is positive and less than the original running sum, the 5 bit compressed value corresponding to the 9 bit difference value will be increased and, if the restored running sum is greater than the original running sum, the 5 bit compressed value corresponding to the 9 bit difference value will be decreased. This process is repeated until the comparator 44 optimizes the 5 bit compressed difference value for a 9 bit difference value, i.e. the restored running sum is approximately equal to the original running sum, and the optimal 5 bit compressed difference value for a 9 bit difference value is output to the respective one of the differential encoders 30, 32, 34.

Thus, there has been described and illustrated herein a method and apparatus for encoding video data which combines an 8 to 5 bit compression of the luminance component with an 8 to 5 bit compression of the chrominance components subsampled over 4 pixels to produce an encoded video signal which significantly reduces the amount of data required to represent an image while avoiding significant detriment to image quality. Those skilled in the art, however, will recognize that many modifications and variations besides those specifically mentioned may be made in the techniques described herein without departing substantially from the concept of the present invention. Accordingly, it should be clearly understood that the form of the invention as described herein is exemplary only and is not intended as a limitation of the scope of the invention.

- 20 -

WHAT IS CLAIMED IS

1. A method for encoding full color video data comprised of a series of pixel elements, said method comprising the steps of:
 - 5 converting said full color video data into luminance and chrominance components;
 - subsampling said chrominance components by determining average chrominance difference values for every sequence of four pixels of said data;
 - 10 differentially compressing said subsampled chrominance components;
 - differentially compressing said luminance components by determining average luminance difference values between successive pixel elements, and compressing said difference values;
 - 15 assembling said differentially compressed subsampled chrominance components and said differentially compressed luminance components of said converted full color video data.

- 20 2. A method for encoding full color video data as set forth in claim 1 wherein said video data is comprised of a series of pixel elements and wherein the steps of differentially compressing said luminance components and said subsampled chrominance components, respectively,
25 further comprise the steps of determining difference values between successive pixel elements and compressing said difference values.

3. A method for encoding full color video data as set forth in claim 1 wherein said determined difference
30 values are 9 bit values and wherein said compressing steps compress said 9 bit determined difference values to 5 bit values.

- 21 -

4. A method for encoding full color video data as set forth in claim 2 wherein said differentially compressing step further includes the steps of:

- 5 compressing each determined 9 bit difference value to a 5 bit difference value;
- expanding each said compressed 5 bit difference value to an 8 bit difference value;
- summing said 9 bit determined difference values resulting in a first 8 bit running sum;
- 10 summing said 8 bit difference values resulting in a second 8 bit running sum;
- comparing said first and second 8 bit running sums; and
- 15 adjusting said compression of 9 bit difference values based upon said comparison of said first and second 8 bit running sums.

5. A method for encoding full color video data according to claim 1 wherein video data is comprised of a series of pixel elements and wherein the step of

20 subsampling said chrominance components further comprises the step of determining average chrominance difference values for every sequence of four pixels of chrominance data.

6. A method for encoding full color video data

25 according to claim 1 and further comprising the steps of:

determining the position and magnitude of a principal color transition within said sequence of four pixels of chrominance data; and

30 appending the position of said principal color transition to said assembled differentially compressed subsampled chrominance components and said differentially compressed luminance components of said converted full color video data.

- 22 -

7. A method for encoding full color video data according to claim 6 and further comprising the steps of:

determining first, second and third chrominance components for said video data;

5 determining a maximum chrominance component differential from said first, second and third components; and

10 determining the position and magnitude of said principal color transition from said maximum chrominance component differential.

8. A method for encoding full color video data according to claim 6 and further comprising the step of selectively averaging said chrominance values based upon the position and magnitude of said principal color
15 transition occurring within said sequence of four pixels to be differentially encoded.

9. A method for encoding full color video data according to claim 8 wherein said step of selectively averaging further includes the steps of:

20 averaging said chrominance values preceding said principal color transition; and

averaging said chrominance values succeeding said principal color transition;

25 wherein said step of selective averaging does not average said chrominance values preceding said principal color transition if a principal color transition occurred in the previous sequence of four pixels but will instead average said chrominance values succeeding said principal color transition in
30 said previous sequence of four pixels.

- 23 -

10. An apparatus for encoding a full color video image comprised of a plurality of pixel elements, comprising:

5 means for converting each pixel element of a full color video image into luminance and chrominance components;

means for subsampling said chrominance components of said plurality of pixel elements by determining average chrominance difference values for every sequence of four of said pixel elements of said data;

means for differentially compressing said luminance components;

15 means for differentially compressing said subsampled chrominance components; and

multiplexing means for assembling said encoded video data signal from said differentially compressed luminance components and said differentially compressed subsampled chrominance components.

20 11. An apparatus for encoding a full color video image according to claim 10 wherein said means for subsampling said chrominance components of said plurality of pixel elements further comprises means for determining average chrominance difference values for every sequence
25 of four of said plurality of pixel elements.

12. An apparatus for encoding a full color video image according to claim 10 and further comprising:

30 means for determining a difference value for said luminance components of successive pixel elements; and

means for compressing said determined difference value for said luminance components of successive pixel elements.

- 24 -

13. An apparatus for encoding a full color video image according to claim 12 and further comprising:

- 5 means for determining a difference value for a first chrominance component averaged for successive pixel elements; and
means for compressing said averaged chrominance difference values.

14. An apparatus for encoding a full color video image according to claim 13 and further comprising:

- 10 means for determining a difference value for a second chrominance component averaged for successive pixel elements; and
means for compressing said second averaged chrominance difference values.

15 15. An apparatus for encoding a full color video image according to claim 14 and further comprising:

- means for calculating chrominance difference values for every sequence of four of said plurality of pixel elements;
20 means for determining the position and magnitude of a principal color transition for four successive pixel elements; and
means for generating a position code based upon said determined position of said principal color
25 transition;
wherein said multiplexing means further comprises means for assembling said encoded video data signal from said differentially compressed luminance components, said differentially compressed
30 subsampled chrominance components and said position code.

- 25 -

16. A protocol for encoding, in a storage medium, video data signals related to a full color image, comprising:

5 means for converting video data signals related to color levels for a full color image into luminance and chrominance components;

means for differentially compressing said luminance components of said full color image;

10 means for subsampling said chrominance components of said full color image;

means for differentially compressing said subsampled chrominance components; and

15 means for encoding, in a storage medium, a video data signal which includes a first field for related to said differentially compressed luminance component, a second field related to said differentially compressed subsampled chrominance component and a third field related to the position of principal color transition for said full color
20 image, said position field determined from said chrominance components.

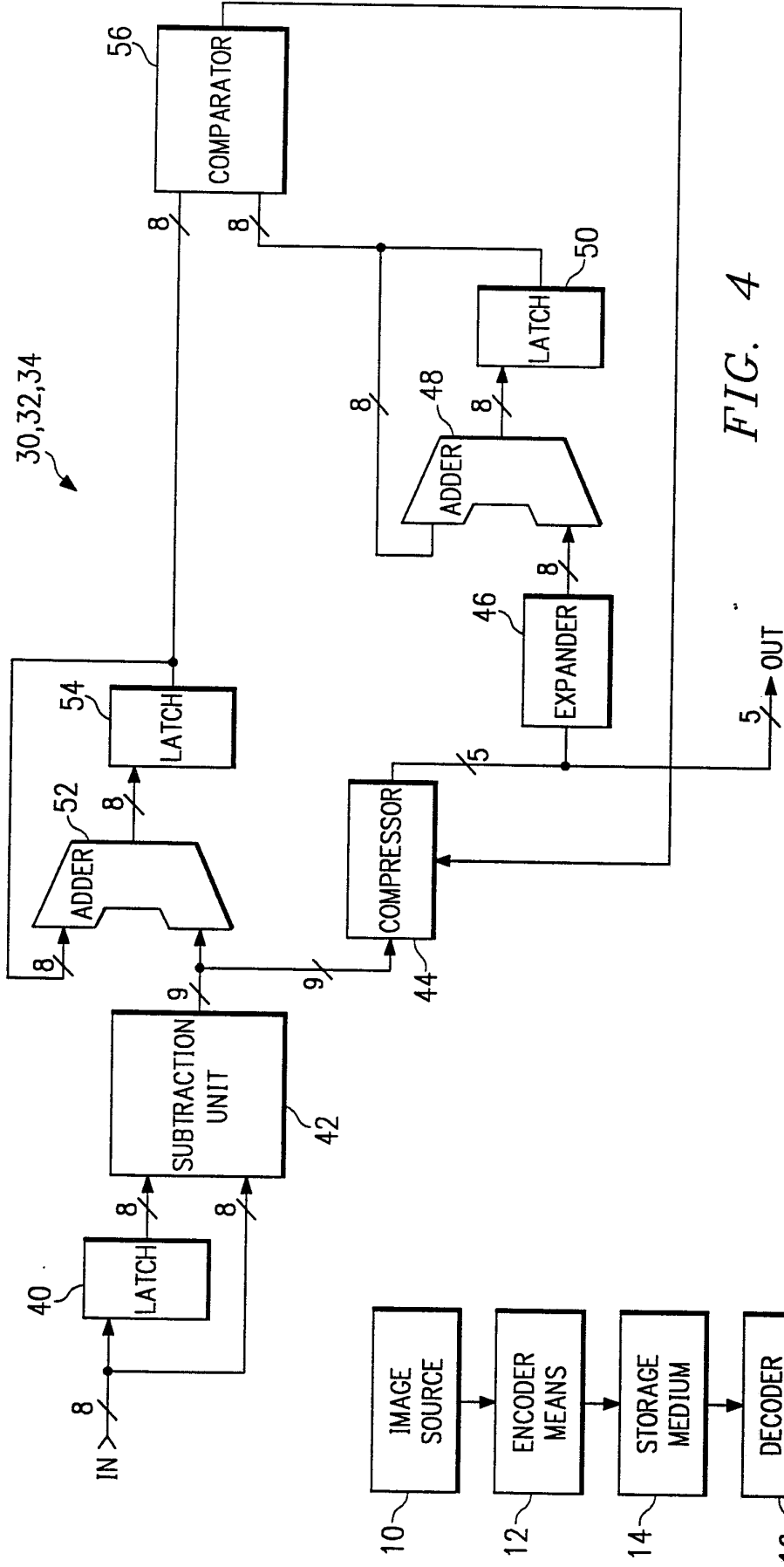

FIG. 1

FIG. 4

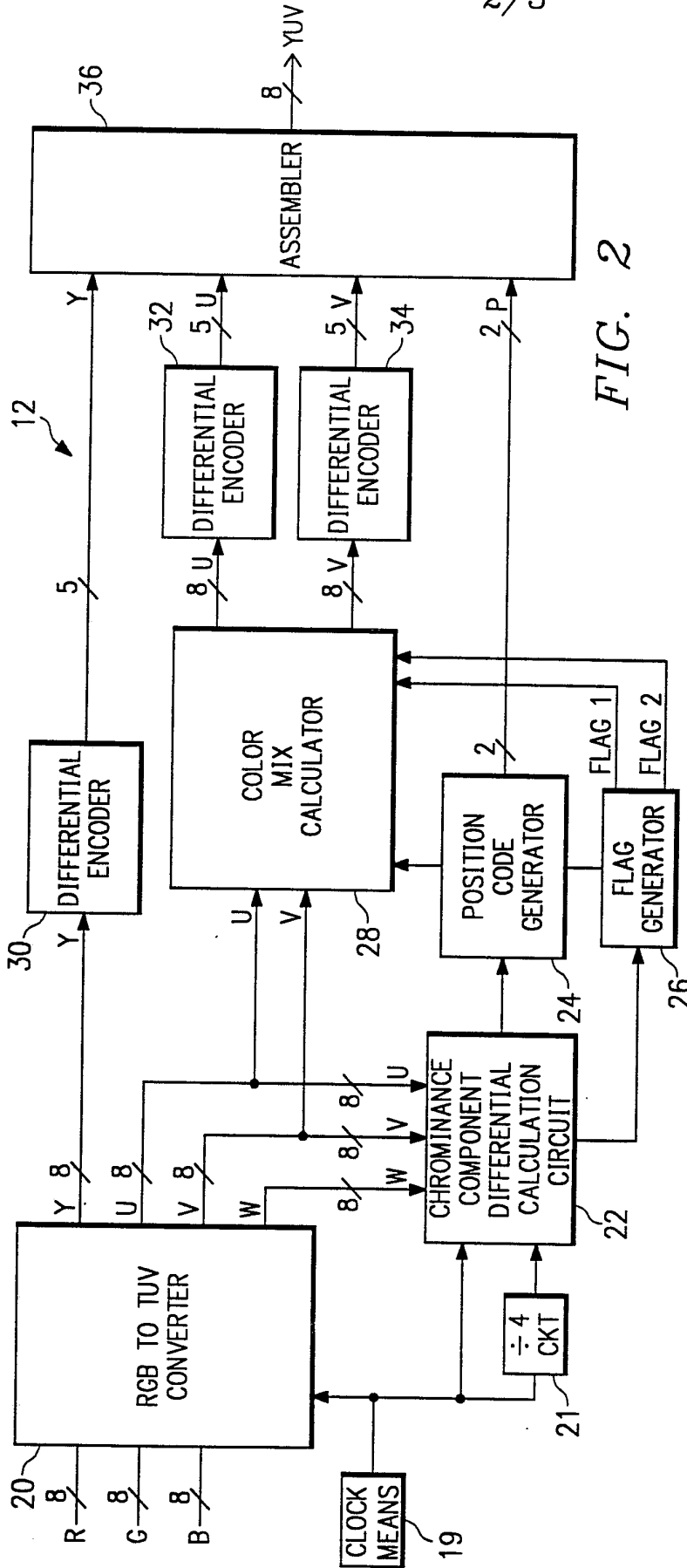

FIG. 2

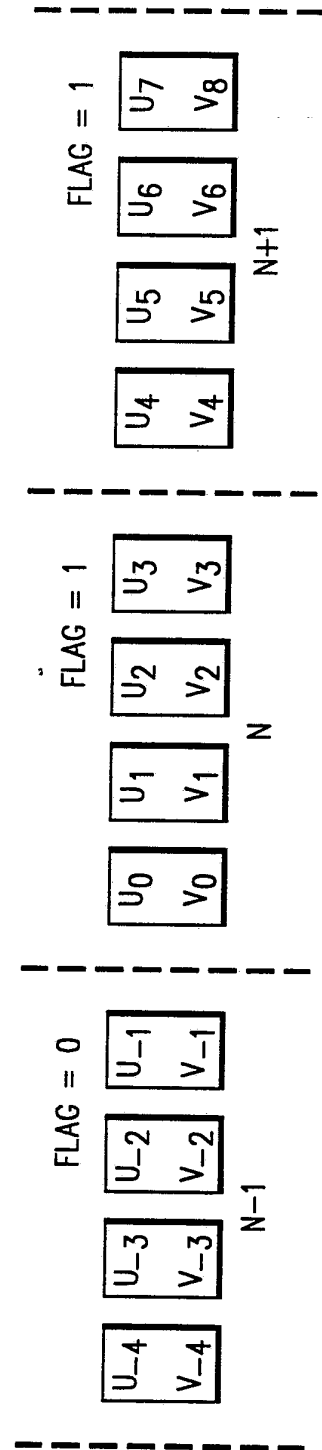

FIG. 3

COLOR MIX DIAGRAM

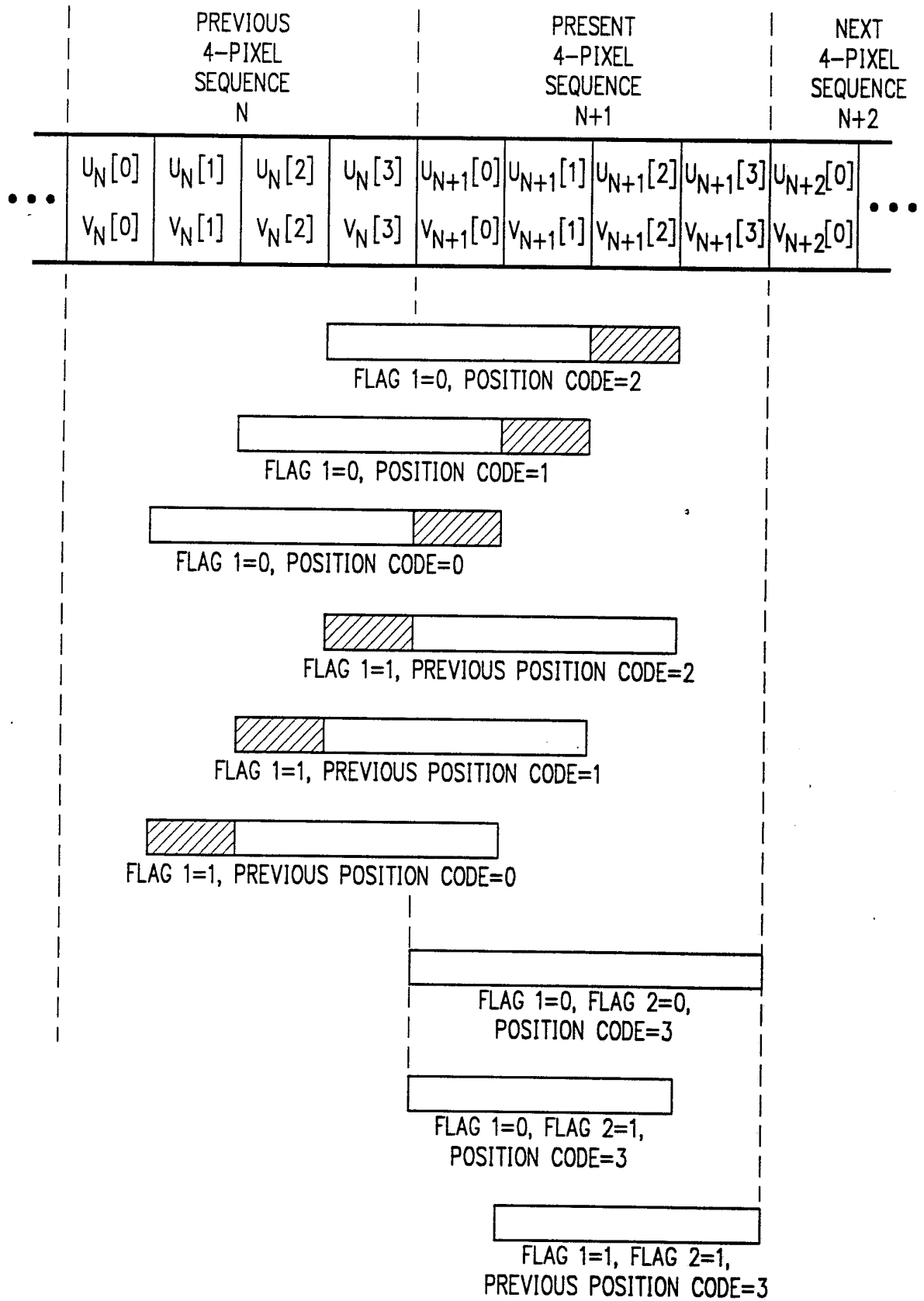

FIG. 5

INTERNATIONAL SEARCH REPORT

International application No.
PCT/US92/07424

A. CLASSIFICATION OF SUBJECT MATTER
 IPC(5) :H04N 11/04, 7/13
 US CL :358/13
 According to International Patent Classification (IPC) or to both national classification and IPC

B. FIELDS SEARCHED
 Minimum documentation searched (classification system followed by classification symbols)
 U.S. : 358/13, 138, 135, 133 H04N 7/13

Documentation searched other than minimum documentation to the extent that such documents are included in the fields searched

Electronic data base consulted during the international search (name of data base and, where practicable, search terms used)

C. DOCUMENTS CONSIDERED TO BE RELEVANT

Category*	Citation of document, with indication, where appropriate, of the relevant passages	Relevant to claim No.
A	US, A, 4,672 (RZESZEWSKI) 09 JUNE 1987 Figs. 1A and 1B.	1-3, 10
A	US, A, 4,716,453 (PAWELSKI) 29 DECEMBER 1987 Figs. 1.	1-2, 10
A	US, A, 4,857,992 (RICHARDS) 15 AUGUST 1989 Fig. 3.	1-2, 10

Further documents are listed in the continuation of Box C. See patent family annex.

* Special categories of cited documents:	"T" later document published after the international filing date or priority date and not in conflict with the application but cited to understand the principle or theory underlying the invention
"A" document defining the general state of the art which is not considered to be part of particular relevance	"X" document of particular relevance; the claimed invention cannot be considered novel or cannot be considered to involve an inventive step when the document is taken alone
"E" earlier document published on or after the international filing date	"Y" document of particular relevance; the claimed invention cannot be considered to involve an inventive step when the document is combined with one or more other such documents, such combination being obvious to a person skilled in the art
"L" document which may throw doubts on priority claim(s) or which is cited to establish the publication date of another citation or other special reason (as specified)	"&" document member of the same patent family
"O" document referring to an oral disclosure, use, exhibition or other means	
"P" document published prior to the international filing date but later than the priority date claimed	

Date of the actual completion of the international search 05 OCTOBER 1992	Date of mailing of the international search report 02 DEC 1992
--	---

Name and mailing address of the ISA/US Commissioner of Patents and Trademarks Box PCT Washington, D.C. 20231 Facsimile No. NOT APPLICABLE	Authorized officer VIC KOSTAK Telephone No. (703) 305-4374
---	--