

(12) **EUROPEAN PATENT SPECIFICATION**

(45) Date of publication and mention of the grant of the patent:
02.03.2005 Bulletin 2005/09

(51) Int Cl.7: **F04B 43/04, F15C 5/00**

(21) Application number: **01128819.8**

(22) Date of filing: **27.06.2000**

(54) **Microfabricated elastomeric valve and pump systems**

Elastisches Mikropumpen- oder Mikroventilsystem

Système de micropompes ou soupapes flexibles

(84) Designated Contracting States:
**AT BE CH CY DE DK ES FI FR GB GR IE IT LI LU
MC NL PT SE**
Designated Extension States:
AL LT LV MK RO SI

(56) References cited:
**EP-A- 0 703 364 EP-A- 0 779 436
EP-A- 0 999 055 US-A- 5 088 515
US-A- 5 346 372 US-A- 5 660 370
US-A- 5 836 750**

(30) Priority: **28.06.1999 US 141503 P
03.08.1999 US 147199 P
03.03.2000 US 186856 P**

(43) Date of publication of application:
10.04.2002 Bulletin 2002/15

(62) Document number(s) of the earlier application(s) in accordance with Art. 76 EPC:
00305389.9 / 1 065 378

(73) Proprietor: **California Institute of Technology
Pasadena, California 92115 (US)**

(72) Inventors:
• **Unger, Marc A.
South San Francisco, California 94080 (US)**
• **Scherer, Axel
Laguna Beach, California 92651 (US)**
• **Quake, Stephen R.
San Marino, California 91108 (US)**
• **Chou, Hou-Pu
Sunnyvale, CA 94086 (US)**
• **Thorsen, Todd A.
Pasadena, California 91104 (US)**

(74) Representative: **Bizley, Richard Edward et al
Hepworth, Lawrence, Bryer & Bizley
Merlin House
Falconry Court
Baker's Lane
Epping Essex CM16 5DQ (GB)**

- **POL VAN DE F C M ET AL: "A THERMO-PNEUMATIC ACTUATION PRINCIPLE FOR A MICROMINIATURE PUMP AND OTHER MICROMECHANICAL DEVICES" SENSORS AND ACTUATORS, ELSEVIER SEQUOIA S.A. LAUSANNE, CH, vol. 17, no. 1/2, 3 May 1989 (1989-05-03), pages 139-143, XP000038020**
- **DUFFY, D. C. ET AL.: "Rapid Prototyping of Microfluidic Systems in Poly(dimethylsiloxane)" ANAL. CHEM., vol. 70, 1998, pages 4974-4984, XP002149044**
- **DUFFY D C ET AL: "PATTERNING ELECTROLUMINESCENT MATERIALS WITH FEATURE SIZES AS SMALL AS 5 MUM USING ELASTOMERIC MEMBRANES AS MASKS FOR DRY LIFT-OFF" ADVANCED MATERIALS,DE,VCH VERLAGSGESELLSCHAFT, WEINHEIM, vol. 11, no. 7, 7 May 1999 (1999-05-07), pages 546-552, XP000849014 ISSN: 0935-9648**
- **XIA, Y., WHITESIDES, G. M.: "Soft Lithography" ANGEW. CHEM. INT. ED., vol. 37, 1998, pages 550-575, XP002149045**
- **BRYZEK J ET AL: "MICROMACHINES ON THE MARCH" IEEE SPECTRUM,US,IEEE INC. NEW YORK, vol. 31, no. 5, 1 May 1994 (1994-05-01), pages 20-31, XP000456261 ISSN: 0018-9235**
- **QIN D ET AL: "ELASTOMERIC LIGHT VALVES" ADVANCED MATERIALS,DE,VCH VERLAGSGESELLSCHAFT, WEINHEIM, vol. 9, no. 5, 1 April 1997 (1997-04-01), pages 407-410, XP000683891 ISSN: 0935-9648**

Note: Within nine months from the publication of the mention of the grant of the European patent, any person may give notice to the European Patent Office of opposition to the European patent granted. Notice of opposition shall be filed in a written reasoned statement. It shall not be deemed to have been filed until the opposition fee has been paid. (Art. 99(1) European Patent Convention).

- RAPP R ET AL: "LIGA MICROPUMP FOR GASES AND LIQUIDS" SENSORS AND ACTUATORS A,CH,ELSEVIER SEQUOIA S.A., LAUSANNE, vol. A40, no. 1, 1994, pages 57-61, XP000434539 ISSN: 0924-4247

Description**CROSS-REFERENCE TO RELATED APPLICATIONS**

[0001] This nonprovisional patent application claims the benefit of the following previously filed provisional patent applications: U.S. provisional patent application no. 60/141,503 filed June 28, 1999, U.S. provisional patent application no. 60/147,199 filed August 3, 1999, and U.S. provisional patent application no. 60/186,856 filed March 3, 2000. The text of these prior provisional patent applications is hereby incorporated by reference.

STATEMENT AS TO RIGHTS TO INVENTIONS MADE UNDER FEDERALLY SPONSORED RESEARCH AND DEVELOPMENT

[0002] The U.S. Government has a paid-up license in this invention and the right in limited circumstances to require the patent owner to license others on reasonable terms as provided for by the terms of Grant No. HG-01642-02. awarded by the National Institute of Health.

TECHNICAL FIELD

[0003] The present invention relates to microfabricated structures and methods for producing microfabricated structures, and to microfabricated systems for regulating fluid-flow.

BACKGROUND OF THE INVENTION

[0004] Various approaches to designing micro-fluidic pumps and valves have been attempted. Unfortunately, each of these approaches suffers from its own limitations.

[0005] The two most common methods of producing microelectromechanical (MEMS) structures such as pumps and valves are silicon-based bulk micro-machining (which is a subtractive fabrication method whereby single crystal silicon is lithographically patterned and then etched to form three-dimensional structures), and surface micro-machining (which is an additive method where layers of semiconductor-type materials such as polysilicon, silicon nitride, silicon dioxide, and various metals are sequentially added and patterned to make three-dimensional structures).

[0006] A limitation of the first approach of silicon-based micro-machining is that the stiffness of the semiconductor materials used necessitates high actuation forces, which in turn result in large and complex designs. In fact, both bulk and surface micro-machining methods are limited by the stiffness of the materials used. In addition, adhesion between various layers of the fabricated device is also a problem. For example, in bulk micro-machining, wafer bonding techniques must be employed to create multilayer structures. On the other hand, when surface micro-machining, thermal stresses

between the various layers of the device limits the total device thickness, often to approximately 20 microns. Using either of the above methods, clean room fabrication and careful quality control are required.

[0007] Duffy et al. (Anal Chem (1998), 70, 4974-4984) discusses microfluidic capillary electrophoresis systems in an elastomeric material, and methods for their manufacture. The paper describes the creation of channels in PDMS, and describes capillary electrophoresis experiments in the channels. There is no discussion of the use of a combination of flow channels and control channels.

SUMMARY OF THE INVENTION

[0008] The present invention sets forth systems for fabricating and operating microfabricated structures such as on/off valves, switching valves, and pumps e. g. made out of various layers of elastomer bonded together. The present structures and methods are ideally suited for controlling and channelling fluid movement, but are not so limited.

[0009] In a first aspect, the invention provides a micro fabricated elastomeric structure, comprising a planar substrate (14); a first elastomeric layer (20) having a top surface, and a bottom surface with flow recesses (21) formed therein; and a second elastomeric layer (22) having a bottom surface with a control recess (23) formed therein, the control recess having both a wide and a narrow flow recess portion disposed along its length; wherein the first layer is positioned on top of the planar substrate forming first and second flow channels (30A, 30B) between the flow recesses of the first elastomeric layer and the planar substrate, and the bottom surface of the second elastomeric layer is bonded onto the top surface of the first elastomeric layer forming a control channel (32) between the control recess of the second elastomeric layer and the top surface of the first elastomeric layer, the control channel having both a wide and a narrow control channel portion corresponding to the wide and narrow control recess portions, with the wide control channel portion being disposed over the first flow channel, and the narrow control portion being disposed over the second flow channel.

[0010] A multilayer soft lithography process can be used to build integrated (i.e. monolithic) microfabricated elastomeric structures of the invention. Advantages of fabricating the present structures by binding together layers of soft elastomeric materials include the fact that the resulting devices are reduced by more than two orders of magnitude in size as compared to silicon-based devices. Further advantages of rapid prototyping, ease of fabrication, and biocompatibility are also achieved.

[0011] Separate elastomeric layers may be fabricated on top of micromachined molds such that recesses are formed in each of the various elastomeric layers. By bonding these various elastomeric layers together, the recesses extending along the various elastomeric lay-

ers form flow channels and control lines through the resulting monolithic, integral elastomeric structure. These flow channels and control lines which are formed in the elastomeric structure can be actuated to function as micro-pumps and micro-valves, as will be explained.

[0012] The monolithic elastomeric structure may be sealed onto the top of a planar substrate, with flow channels being formed between the surface of the planar substrate and the recesses which extend along the bottom surface of the elastomeric structure.

[0013] The present monolithic elastomeric structures may be constructed by bonding together two separate layers of elastomer with each layer first being separately cast from a micromachined mold. Preferably, the elastomer used is a two-component addition cure material in which the bottom elastomeric layer has an excess of one component, while the top elastomeric layer has an excess of another component. In an exemplary embodiment, the elastomer used is silicone rubber. Two layers of elastomer are cured separately. Each layer is separately cured before the top layer is positioned on the bottom layer. The two layers are then bonded together. Each layer preferably has an excess of one of the two components, such that reactive molecules remain at the interface between the layers. The top layer is assembled on top of the bottom layer and heated. The two layers bond irreversibly such that the strength of the interface approaches or equals the strength of the bulk elastomer. This creates a monolithic three-dimensional patterned structure composed entirely of two layers of bonded together elastomer. Additional layers may be added by simply repeating the process, wherein new layers, each having a layer of opposite "polarity" are cured, and thereby bonded together.

[0014] In a second method, a first photoresist layer is deposited on top of a first elastomeric layer. The first photoresist layer is then patterned to leave a line or pattern of lines of photoresist on the top surface of the first elastomeric layer. Another layer of elastomer is then added and cured, encapsulating the line or pattern of lines of photoresist. A second photoresist layer is added and patterned, and another layer of elastomer added and cured, leaving line and patterns of lines of photoresist encapsulated in a monolithic elastomer structure. This process may be repeated to add more encapsulated patterns and elastomer layers. Thereafter, the photoresist is removed leaving flow channel(s) and control line(s) in the spaces which had been occupied by the photoresist. This process may be repeated to create elastomer structures having a multitude of layers.

[0015] An advantage of patterning moderate sized features (≥ 10 microns) using a photoresist method is that a high resolution transparency film can be used as a contact mask. This allows a single researcher to design, print, pattern the mold, and create a new set of cast elastomer devices, typically all within 24 hours.

[0016] A further advantage of either above methods is that due to its monolithic or integral nature, (i.e., all

the layers are composed of the same material) is that interlayer adhesion failures and thermal stress problems are completely avoided.

[0017] Further advantages of the present invention's preferred use of a silicone rubber or elastomer such as RTV 615 manufactured by General Electric, is that it is transparent to visible light, making a multilayer optical trains possible, thereby allowing optical interrogation of various channels or chambers in the microfluidic device. As appropriately shaped elastomer layers can serve as lenses and optical elements, bonding of layers allows the creation of multilayer optical trains. In addition, GE RTV 615 elastomer is biocompatible. Being soft, closed valves form a good seal even if there are small particulates in the flow channel. Silicone rubber is also biocompatible and inexpensive, especially when compared with a single crystal silicon.

[0018] Monolithic elastomeric valves and pumps also avoid many of the practical problems affecting flow systems based on electro-osmotic flow. Typically, electro-osmotic flow systems suffer from bubble formation around the electrodes and the flow is strongly dependent on the composition of the flow medium. Bubble formation seriously restricts the use of electro-osmotic flow in microfluidic devices, making it difficult to construct functioning integrated devices. The magnitude of flow and even its direction typically depends in a complex fashion on ionic strength and type, the presence of surfactants and the charge on the walls of the flow channel. Moreover, since electrolysis is taking place continuously, the eventual capacity of buffer to resist pH changes may also be reached. Furthermore, electro-osmotic flow always occurs in competition with electrophoresis. As different molecules may have different electrophoretic mobilities, unwanted electrophoretic separation may occur in the electro-osmotic flow. Finally, electro-osmotic flow can not easily be used to stop flow, halt diffusion, or to balance pressure differences.

[0019] A further advantage of the present monolithic elastomeric valve and pump structures are that they can be actuated at very high speeds. For example, the present inventors have achieved a response time for a valve with aqueous solution therein on the order of one millisecond, such that the valve opens and closes at speeds approaching or exceeding 100 Hz. In particular, a non-exclusive list of ranges of cycling speeds for the opening and closing of the valve structure include between about 0.001 and 10000 ms, between about 0.01 and 1000 ms, between about 0.1 and 100 ms, and between about 1 and 10 ms. The cycling speeds depend upon the composition and structure of a valve used for a particular application and the method of actuation, and thus cycling speeds outside of the listed ranges would fall within the scope of the present invention.

[0020] Further advantages of the present pumps and valves are that their small size makes them fast and their softness contributes to making them durable. Moreover, as they close linearly with differential applied pressure,

this linear relationship allows fluid metering and valve closing in spite of high back pressures.

[0021] In various embodiments of the invention, a plurality of flow channels pass through the elastomeric structure with a second flow channel extending across and above a first flow channel. A thin membrane of elastomer separates the first and second flow channels. As will be explained, downward movement of this membrane (due to the second flow channel being pressurized or the membrane being otherwise actuated) will cut off flow passing through the lower flow channel.

[0022] In optional preferred embodiments of the present systems, a plurality of individually addressable valves are formed connected together in an elastomeric structure and are then activated in sequence such that peristaltic pumping is achieved. More complex systems including networked or multiplexed control systems, selectively addressable valves disposed in a grid of valves, networked or multiplexed reaction chamber systems and biopolymer synthesis systems are also described.

[0023] Microfabricated elastomeric structures with the present invention comprise an elastomeric block formed with first and second microfabricated recesses therein, a portion of the elastomeric block deflectable when the portion is actuated.

[0024] One method of microfabricating an elastomeric structure comprises the steps of microfabricating a first elastomeric layer, microfabricating a second elastomeric layer; positioning the second elastomeric layer on top of the first elastomeric layer, and bonding a bottom surface of the second elastomeric layer onto a top surface of the first elastomeric layer.

[0025] A first alternative method of microfabricating an elastomeric structure comprises the steps of forming a first elastomeric layer on top of a first micromachined mold, the first micromachined mold having at least one first raised protrusion which forms at least one first channel in the bottom surface of the first elastomeric layer. A second elastomeric layer is formed on top of a second micromachined mold, the second micromachined mold having at least one second raised protrusion which forms at least one second channel in the bottom surface of the second elastomeric layer. The bottom surface of the second elastomeric layer is bonded onto a top surface of the first elastomeric layer such that the at least one second channel is enclosed between the first and second elastomeric layers.

[0026] A second alternative method of microfabricating an elastomeric structure in accordance with the present invention comprises the steps of forming a first elastomeric layer on top of a substrate, curing the first elastomeric layer, and depositing a first sacrificial layer on the top surface of the first elastomeric layer. A portion of the first sacrificial layer is removed such that a first pattern of sacrificial material remains on the top surface of the first elastomeric layer. A second elastomeric layer is formed over the first elastomeric layer thereby encapsulating the first pattern of sacrificial material between

the first and second elastomeric layers. The second elastomeric layer is cured and then sacrificial material is removed thereby forming at least one first recess between the first and second layers of elastomer.

[0027] In a second aspect, the invention provides, a method for controlling a flow of a fluid in a microfluidic structure comprising the steps of: (i) providing the elastomeric structure, comprising: a planar substrate (14); a first elastomeric layer (20) having a top surface, and a bottom surface with first and second flow recesses (21) formed therein; and a second elastomeric layer (22) having a bottom surface with a control recess (23) formed therein, the control recess having both a wide and a narrow flow recess portion disposed along its length; wherein the first layer is positioned on top of the planar substrate forming first and second flow channels (30A, 30B) between the flow recesses of the first elastomeric layer and the planar substrate, and the bottom surface of the second elastomeric layer is bonded onto the top surface of the first elastomeric layer forming a control channel (32) between the control recess of the second elastomeric layer and the top surface of the first elastomeric layer, the control channel having both a wide and a narrow control channel portion corresponding to the wide and narrow control recess portions, with the wide control channel portion being disposed over the first flow channel, and the narrow control portion being disposed over the second flow channel, and a deflectable region (25) being formed between the wide control channel portion and the first flow channel; (ii) controlling the control channel pressure so that it is greater than the pressure within the flow channel so that the deflectable region deflects into the first flow channel to alter the flow of the fluid within the first flow channel and the fluid flow in the second flow channel is either not altered or altered less than the fluid flow in the first flow channel.

[0028] In other optional preferred embodiments, magnetic or conductive materials can be added to make layers of the elastomer magnetic or electrically conducting, thus enabling the creation of all elastomer electromagnetic devices.

BRIEF DESCRIPTION OF THE DRAWINGS

Part I - Figs. 1 to 7A illustrate successive steps of a first method of fabricating the present invention, as follows:

[0029]

Fig. 1 is an illustration of a first elastomeric layer formed on top of a micromachined mold.
 Fig. 2 is an illustration of a second elastomeric layer formed on top of a micromachined mold.
 Fig. 3 is an illustration of the elastomeric layer of Fig. 2 removed from the micromachined mold and positioned over the top of the elastomeric layer of Fig. 1

Fig. 4 is an illustration corresponding to Fig. 3, but showing the second elastomeric layer positioned on top of the first elastomeric layer.

Fig. 5 is an illustration corresponding to Fig. 4, but showing the first and second elastomeric layers bonded together.

Fig. 6 is an illustration corresponding to Fig. 5, but showing the first micromachine mold removed and a planar substrate positioned in its place.

Fig. 7A is an illustration corresponding to Fig. 6, but showing the elastomeric structure sealed onto the planar substrate.

Figs. 7B is a front sectional view corresponding to Fig. 7A, showing an open flow channel.

Figs. 7C-7G are illustrations showing steps of a method for forming an elastomeric structure having a membrane formed from a separate elastomeric layer.

Part II - Fig. 7H show the closing of a first flow channel by pressurizing a second flow channel, as follows:

[0030]

Fig. 7H corresponds to Fig. 7A, but shows a first flow channel closed by pressurization in second flow channel.

Part III - Figs. 8 to 18 illustrate successive steps of a second method of fabricating the present invention, as follows:

[0031]

Fig. 8 is an illustration of a first elastomeric layer deposited on a planar substrate.

Fig. 9 is an illustration showing a first photoresist layer deposited on top of the first elastomeric layer of Fig. 8.

Fig. 10 is an illustration showing the system of Fig. 9, but with a portion of the first photoresist layer removed, leaving only a first line of photoresist.

Fig. 11 is an illustration showing a second elastomeric layer applied on top of the first elastomeric layer over the first line of photoresist of Fig. 10, thereby encasing the photoresist between the first and second elastomeric layers.

Fig. 12 corresponds to Fig. 11, but shows the integrated monolithic structure produced after the first and second elastomer layers have been bonded together.

Fig. 13 is an illustration showing a second photoresist layer deposited on top of the integral elastomeric structure of Fig. 12.

Fig. 14 is an illustration showing the system of Fig. 13, but with a portion of the second photoresist layer removed, leaving only a second line of photoresist.

Fig. 15 is an illustration showing a third elastomer layer applied on top of the second elastomeric layer and over the second line of photoresist of Fig. 14, thereby encapsulating the second line of photoresist between the elastomeric structure of Fig. 12 and the third elastomeric layer.

Fig. 16 corresponds to Fig. 15, but shows the third elastomeric layer cured so as to be bonded to the monolithic structure composed of the previously bonded first and second elastomer layers.

Fig. 17 corresponds to Fig. 16, but shows the first and second lines of photoresist removed so as to provide two perpendicular overlapping, but not intersecting, flow channels passing through the integrated elastomeric structure.

Fig. 18 is an illustration showing the system of Fig. 17, but with the planar substrate thereunder removed.

Part IV - Figs. 19 and 20 show further details of different flow channel cross-sections, as follows:

[0032]

Fig. 19 shows a rectangular cross-section of a first flow channel.

Fig. 20 shows the flow channel cross section having a curved upper surface.

Part V - Figs. 21 to 24 show experimental results achieved by preferred embodiments of the present microfabricated valve:

[0033]

Fig. 21 illustrates valve opening vs. applied pressure for various flow channels.

Fig. 22 illustrates time response of a $100\mu\text{m}\times 100\mu\text{m}\times 10\mu\text{m}$ RTV microvalve.

Part VI - Figs. 23A to 33 show various microfabricated structures, networked together

[0034]

Fig. 23A is a top schematic view of an on/off valve.

Fig. 23B is a sectional elevation view along line 23B-23B in Fig. 23A

Fig. 24 is a top schematic view of a peristaltic pumping system.

Fig. 24B is a sectional elevation view along line 24B-24B in Fig. 24A

Fig. 25 is a graph showing experimentally achieved pumping rates vs. frequency for an embodiment of the peristaltic pumping system of Fig. 24.

Fig. 26A is a top schematic view of one control line actuating multiple flow lines simultaneously.

Fig. 26B is a sectional elevation view along line

26B-26B in Fig. 26A

Fig. 27 is a schematic illustration of a multiplexed system of the invention, adapted to permit flow through various channels.

Fig. 28A is a plan view of a flow layer of an addressable reaction chamber structure.

Fig. 28B is a bottom plan view of a control channel layer of an addressable reaction chamber structure.

Fig. 28C is an exploded perspective view of the addressable reaction chamber structure formed by bonding the control channel layer of Fig 28B to the top of the flow layer of Fig 28A.

Fig. 28D is a sectional elevation view corresponding to Fig. 28C, taken along line 28D-28D in Fig. 28C.

Fig. 29 is a schematic of a system adapted to selectively direct fluid flow into any of an array of reaction wells.

Fig. 30 is a schematic of a system adapted for selectable lateral flow between parallel flow channels.

Fig. 31A is a bottom plan view of first layer (i.e.: the flow channel layer) of elastomer of a switchable flow array.

Fig. 31B is a bottom plan view of a control channel layer of a switchable flow array.

Fig. 31 C shows the alignment of the first layer of elastomer of Fig. 31A with one set of control channels in the second layer of elastomer of Fig. 31B.

Fig. 31D also shows the alignment of the first layer of elastomer of Fig. 31A with the other set of control channels in the second layer of elastomer of Fig. 31B.

Fig. 32 is a schematic of an integrated system for biopolymer synthesis.

Fig. 33 is a schematic of a further integrated system for biopolymer synthesis.

Fig. 34 is an optical micrograph of a section of a test structure having seven layers of elastomer bonded together.

Figs. 35A-35D show the steps of one embodiment of a method for fabricating an elastomer layer having a vertical via formed therein.

Fig. 36 shows one embodiment of a sorting apparatus in accordance with the present invention.

Fig. 37 shows an embodiment of an apparatus for flowing process gases over a semiconductor wafer in accordance with the present invention.

Fig. 38 shows an exploded view of one embodiment of a micro-mirror array structure in accordance with the present invention.

Fig. 39 shows a perspective view of a first embodiment of a refractive device in accordance with the present invention.

Fig. 40 shows a perspective view of a second embodiment of a refractive device in accordance with the present invention.

Fig. 41 shows a perspective view of a third embodiment of a refractive device in accordance with the present invention.

Figs. 42A-42J show views of one embodiment of a normally-closed valve structure in accordance with the present invention.

Figs. 43 shows a plan view of one embodiment of a device for performing separations in accordance with the present invention.

Figs. 44A-44D show plan views illustrating operation of one embodiment of a cell pen structure in accordance with the present invention.

Figs. 45A-45B show plan and cross-sectional views illustrating operation of one embodiment of a cell cage structure in accordance with the present invention.

Figs. 46A-46B show cross-sectional views illustrating operation of one embodiment of a cell grinder structure in accordance with the present invention.

Fig. 47 shows a plan view of one embodiment of a pressure oscillator structure in accordance with the present invention.

Figs. 48A and 48B show plan views illustrating operation of one embodiment of a side-actuated valve structure in accordance with the present invention.

Fig. 49 plots Young's modulus versus percentage dilution of GE RTV 615 elastomer with GE SF96-50 silicone fluid.

DETAILED DESCRIPTION OF THE PRESENT INVENTION

[0035] The present invention comprises a variety of microfabricated elastomeric structures which may be used as pumps or valves. Methods of fabricating the preferred elastomeric structures are also set forth.

Methods of Fabricating the Present Invention:

[0036] Two exemplary methods of fabricating the present invention are provided herein. It is to be understood that the present invention is not limited to fabrication by one or the other of these methods. Rather, other suitable methods of fabricating the present microstructures, including modifying the present methods, are also contemplated.

[0037] Figs. 1 to 7B illustrate sequential steps of a first preferred method of fabricating the present microstructure, (which may be used as a pump or valve). Figs. 8 to 18 illustrate sequential steps of a second preferred method of fabricating the present microstructure, (which also may be used as a pump or valve).

[0038] As will be explained, the preferred method of Figs. 1 to 7B involves using pre-cured elastomer layers which are assembled and bonded. Conversely, the preferred method of Figs. 8 to 18 involves curing each layer of elastomer "in place". In the following description "channel" refers to a recess in the elastomeric structure which can contain a flow of fluid or gas.

The First Exemplary Method:

[0039] Referring to Fig. 1, a first micro-machined mold 10 is provided. Micromachined mold 10 may be fabricated by a number of conventional silicon processing methods, including but not limited to photolithography, ion-milling, and electron beam lithography.

[0040] As can be seen, micro-machined mold 10 has a raised line or protrusion 11 extending therealong. A first elastomeric layer 20 is cast on top of mold 10 such that a first recess 21 will be formed in the bottom surface of elastomeric layer 20, (recess 21 corresponding in dimension to protrusion 11), as shown.

[0041] As can be seen in Fig. 2, a second micro-machined mold 12 having a raised protrusion 13 extending therealong is also provided. A second elastomeric layer 22 is cast on top of mold 12, as shown, such that a recess 23 will be formed in its bottom surface corresponding to the dimensions of protrusion 13.

[0042] As can be seen in the sequential steps illustrated in Figs. 3 and 4, second elastomeric layer 22 is removed from mold 12 and placed on top of first elastomeric layer 20. As can be seen, recess 23 extending along the bottom surface of second elastomeric layer 22 will form a flow channel 32.

[0043] Referring to Fig. 5, the separate first and second elastomeric layers 20 and 22 (Fig. 4) are then bonded together to form an integrated (i.e.: monolithic) elastomeric structure 24.

[0044] As can be seen in the sequential step of Figs. 6 and 7A, elastomeric structure 24 is then removed from mold 10 and positioned on top of a planar substrate 14. As can be seen in Fig. 7A and 7B, when elastomeric structure 24 has been sealed at its bottom surface to planar substrate 14, recess 21 will form a flow channel 30.

[0045] The present elastomeric structures form a reversible hermetic seal with nearly any smooth planar substrate. An advantage to forming a seal this way is that the elastomeric structures may be peeled up, washed, and re-used. In preferred aspects, planar substrate 14 is glass. A further advantage of using glass is that glass is transparent, allowing optical interrogation of elastomer channels and reservoirs: Alternatively, the elastomeric structure may be bonded onto a flat elastomer layer by the same method as described above, forming a permanent and high-strength bond. This may prove advantageous when higher back pressures are used.

[0046] As can be seen in Fig. 7A and 7B, flow channels 30 and 32 are preferably disposed at an angle to one another with a small membrane 25 of substrate 24 separating the top of flow channel 30 from the bottom of flow channel 32.

[0047] In preferred embodiments, planar substrate 14 is glass. An advantage of using glass is that the present elastomeric structures may be peeled up, washed and reused. A further advantage of using glass is that optical

sensing may be employed. Alternatively, planar substrate 14 may be an elastomer itself, which may prove advantageous when higher back pressures are used.

[0048] The method of fabrication just described may be varied to form a structure having a membrane composed of an elastomeric material different than that forming the walls of the channels of the device. This variant fabrication method is illustrated in Figs. 7C-7G.

[0049] Referring to Fig. 7C, a first micro-machined mold 10 is provided. Micromachined mold 10 has a raised line or protrusion 11 extending therealong. In Fig. 7D, first elastomeric layer 20 is cast on top of first micro-machined mold 10 such that the top of the first elastomeric layer 20 is flush with the top of raised line or protrusion 11. This may be accomplished by carefully controlling the volume of elastomeric material spun onto mold 10 relative to the known height of raised line 11. Alternatively, the desired shape could be formed by injection molding.

[0050] In Fig. 7E, second micro-machined mold 12 having a raised protrusion 13 extending therealong is also provided. Second elastomeric layer 22 is cast on top of second mold 12 as shown, such that recess 23 is formed in its bottom surface corresponding to the dimensions of protrusion 13.

[0051] In Fig. 7F, second elastomeric layer 22 is removed from mold 12 and placed on top of third elastomeric layer 20 to form integral elastomeric block 224 using techniques described in detail below. At this point in the process, recess 23 formerly occupied by raised line 13 will form flow channel 23.

[0052] In Fig. 7G, elastomeric block 224 is placed on top of first micro-machined mold 10 and first elastomeric layer 20. Elastomeric block and first elastomeric layer 20 are then bonded together to form an integrated (i.e.: monolithic) elastomeric structure 24 having a membrane composed of a separate elastomeric layer 222.

[0053] When elastomeric structure 24 has been sealed at its bottom surface to a planar substrate in the manner described above in connection with FIG. 7A, the recess formerly occupied by raised line 11 will form flow channel 30.

[0054] The variant fabrication method illustrated above in conjunction with FIGS. 7C-7G offers the advantage of permitting the membrane portion to be composed of a separate material than the elastomeric material of the remainder of the structure. This is important because the thickness and elastic properties of the membrane play a key role in operation of the device. Moreover, this method allows the separate elastomer layer to readily be subjected to conditioning prior to incorporation into the elastomer structure. As discussed in detail below, examples of potentially desirable condition include the introduction of magnetic or electrically conducting species to permit actuation of the membrane, and/or the introduction of dopant into the membrane in order to alter its elasticity.

[0055] While the above method is illustrated in connection with forming various shaped elastomeric layers formed by replication molding on top of a micromachined mold, the present invention is not limited to this technique. Other techniques could be employed to form the individual layers of shaped elastomeric material that are to be bonded together. For example, a shaped layer of elastomeric material could be formed by laser cutting or injection molding, or by methods utilizing chemical etching and/or sacrificial materials as discussed below in conjunction with the second exemplary method.

The Second Exemplary Method:

[0056] A second exemplary method of an elastomeric structure which may be used as a pump or valve is set forth in the sequential steps shown in Figs. 8-18.

[0057] In this method, flow and control channels are defined by first patterning photoresist on the surface of an elastomeric layer (or other substrate, which may include glass) leaving a raised line photoresist where a channel is desired. Next, a second layer of elastomer is added thereover and a second photoresist is patterned on the second layer of elastomer leaving a raised line photoresist where a channel is desired. A third layer of elastomer is deposited thereover. Finally, the photoresist is removed by dissolving it out of the elastomer with an appropriate solvent, with the voids formed by removal of the photoresist becoming the flow channels passing through the substrate.

[0058] Referring first to Fig. 8, a planar substrate 40 is provided. A first elastomeric layer 42 is then deposited and cured on top of planar substrate 40. Referring to Fig. 9, a first photoresist layer 44A is then deposited over the top of elastomeric layer 42. Referring to Fig. 10, a portion of photoresist layer 44A is removed such that only a first line of photoresist 44B remains as shown. Referring to Fig. 11, a second elastomeric layer 46 is then deposited over the top of first elastomeric layer 42 and over the first line of photoresist 44B as shown, thereby encasing first line of photoresist 44B between first elastomeric layer 42 and second elastomeric layer 46. Referring to Fig. 12, elastomeric layers 46 is then cured on layer 42 to bond the layers together to form a monolithic elastomeric substrate 45.

[0059] Referring to Fig. 13, a second photoresist layer 48A is then deposited over elastomeric structure 45. Referring to Fig. 14, a portion of second photoresist layer 48A is removed, leaving only a second photoresist line 48B on top of elastomeric structure 45 as shown. Referring to Fig. 15, a third elastomeric layer 50 is then deposited over the top of elastomeric structure 45 (comprised of second elastomeric layer 42 and first line of photoresist 44B) and second photoresist line 48B as shown, thereby encasing the second line of photoresist 48B between elastomeric structure 45 and third elastomeric layer 50.

[0060] Referring to Fig. 16, third elastomeric layer 50

and elastomeric structure 45 (comprising first elastomeric layer 42 and second elastomeric layer 46 bonded together) is then bonded together forming a monolithic elastomeric structure 47 having photoresist lines 44B and 48B passing therethrough as shown. Referring to Fig. 17, photoresist lines 44B, 48B are then removed (for example, by a solvent) such that a first flow channel 60 and a second flow channel 62 are provided in their place, passing through elastomeric structure 47 as shown. Lastly, referring to Fig. 18, planar substrate 40 can be removed from the bottom of the integrated monolithic structure.

[0061] The method described in Figs. 8-18 fabricates a patterned elastomer structure utilizing development of photoresist encapsulated within elastomer material. However, the methods in accordance with the present invention are not limited to utilizing photoresist. Other materials such as metals could also serve as sacrificial materials to be removed selective to the surrounding elastomer material, and the method would remain within the scope of the present invention. For example, as described in detail below in connection with Figs. 35A-35D, gold metal may be etched selective to RTV 615 elastomer utilizing the appropriate chemical mixture.

Preferred Layer and Channel Dimensions:

[0062] Microfabricated refers to the size of features of an elastomeric structure in accordance with the present invention. In general, variation in at least one dimension of microfabricated structures is controlled to the micron level, with at least one dimension being microscopic (i. e. below 1000 μm). Microfabrication typically involves semiconductor or MEMS fabrication techniques such as photolithography and spincoating that are designed for to produce feature dimensions on the microscopic level, with at least some of the dimension of the microfabricated structure requiring a microscope to reasonably resolve/image the structure.

[0063] In preferred embodiments, flow channels 30, 32, 60 and 62 preferably have width-to-depth ratios of about 10:1. A non-exclusive list of other ranges of width-to-depth ratios in accordance with embodiments of the present invention is 0.1:1 to 100:1, more preferably 1:1 to 50:1, more preferably 2:1 to 20:1, and most preferably 3:1 to 15:1. In an exemplary aspect, flow channels 30, 32, 60 and 62 have widths of about 1 to 1000 microns. A non-exclusive list of other ranges of widths of flow channels in accordance with embodiments of the present invention is 0.01 to 1000 microns, more preferably 0.05 to 1000 microns, more preferably 0.2 to 500 microns, more preferably 1 to 250 microns, and most preferably 10 to 200 microns. Exemplary channel widths include 0.1 μm , 1 μm , 2 μm , 5 μm , 10 μm , 20 μm , 30 μm , 40 μm , 50 μm , 60 μm , 70 μm , 80 μm , 90 μm , 100 μm , 110 μm , 120 μm , 130 μm , 140 μm , 150 μm , 160 μm , 170 μm , 180 μm , 190 μm , 200 μm , 210 μm , 220 μm , 230 μm , 240 μm , and 250 μm .

[0064] Flow channels 30, 32, 60, and 62 have depths of about 1 to 100 microns. A non-exclusive list of other ranges of depths of flow channels in accordance with embodiments of the present invention is 0.01 to 1000 microns, more preferably 0.05 to 500 microns, more preferably 0.2 to 250 microns, and more preferably 1 to 100 microns, more preferably 2 to 20 microns, and most preferably 5 to 10 microns. Exemplary channel depths include including 0.01 μm , 0.02 μm , 0.05 μm , 0.1 μm , 0.2 μm , 0.5 μm , 1 μm , 2 μm , 3 μm , 4 μm , 5 μm , 7.5 μm , 10 μm , 12.5 μm , 15 μm , 17.5 μm , 20 μm , 22.5 μm , 25 μm , 30 μm , 40 μm , 50 μm , 75 μm , 100 μm , 150 μm , 200 μm , and 250 μm .

[0065] The flow channels are not limited to these specific dimension ranges and examples given above, and may vary in width in order to affect the magnitude of force required to deflect the membrane as discussed at length below in conjunction with Fig. 27. For example, extremely narrow flow channels having a width on the order of 0.01 μm may be useful in optical and other applications, as discussed in detail below. Elastomeric structures which include portions having channels of even greater width than described above are also contemplated by the present invention, and examples of applications of utilizing such wider flow channels include fluid reservoir and mixing channel structures.

[0066] Elastomeric layer 22 may be cast thick for mechanical stability. In an exemplary embodiment, layer 22 is 50 microns to several centimeters thick, and more preferably approximately 4 mm thick. A non-exclusive list of ranges of thickness of the elastomer layer in accordance with other embodiments of the present invention is between about 0.1 micron to 10 cm, 1 micron to 5 cm, 10 microns to 2 cm, 100 microns to 10 mm.

[0067] Accordingly, membrane 25 of Fig. 7B separating flow channels 30 and 32 has a typical thickness of between about 0.01 and 1000 microns, more preferably 0.05 to 500 microns, more preferably 0.2 to 250, more preferably 1 to 100 microns, more preferably 2 to 50 microns, and most preferably 5 to 40 microns. As such, the thickness of elastomeric layer 22 is about 100 times the thickness of elastomeric layer 20. Exemplary membrane thicknesses include 0.01 μm , 0.02 μm , 0.03 μm , 0.05 μm , 0.1 μm , 0.2 μm , 0.3 μm , 0.5 μm , 1 μm , 2 μm , 3 μm , 5 μm , 7.5 μm , 10 μm , 12.5 μm , 15 μm , 17.5 μm , 20 μm , 22.5 μm , 25 μm , 30 μm , 40 μm , 50 μm , 75 μm , 100 μm , 150 μm , 200 μm , 250 μm , 300 μm , 400 μm , 500 μm , 750 μm , and 1000 μm .

[0068] Similarly, first elastomeric layer 42 may have a preferred thickness about equal to that of elastomeric layer 20 or 22; second elastomeric layer 46 may have a preferred thickness about equal to that of elastomeric layer 20; and third elastomeric layer 50 may have a preferred thickness about equal to that of elastomeric layer 22.

Multilayer Soft Lithography Construction Techniques and Materials:

Soft Lithographic Bonding:

[0069] Preferably, elastomeric layers 20 and 22 (or elastomeric layers 42, 46 and 50) are bonded together chemically, using chemistry that is intrinsic to the polymers comprising the patterned elastomer layers. Most preferably, the bonding comprises two component "addition cure" bonding.

[0070] The various layers of elastomer may be bound together in a heterogenous bonding in which the layers have a different chemistry. Alternatively, a homogenous bonding may be used in which all layers would be of the same chemistry. Thirdly, the respective elastomer layers may optionally be glued together by an adhesive instead. Fourthly, the elastomeric layers may be thermoset elastomers bonded together by heating.

[0071] The elastomeric layers may be composed of the same elastomer material, with the same chemical entity in one layer reacting with the same chemical entity in the other layer to bond the layers together.

[0072] Bonding between polymer chains of like elastomer layers may result from activation of a crosslinking agent due to light, heat, or chemical reaction with a separate chemical species.

[0073] Alternatively in a heterogeneous aspect, the elastomeric layers are composed of different elastomeric materials, with a first chemical entity in one layer reacting with a second chemical entity in another layer. In one exemplary heterogenous aspect, the bonding process used to bind respective elastomeric layers together may comprise bonding together two layers of RTV 615 silicone. RTV 615 silicone is a two-part addition-cure silicone rubber. Part A contains vinyl groups and catalyst; part B contains silicon hydride (Si-H) groups. The conventional ratio for RTV 615 is 10A:1B. For bonding, one layer may be made with 30A:1B (i.e. excess vinyl groups) and the other with 3A:1B (i.e. excess Si-H groups). Each layer is cured separately. When the two layers are brought into contact and heated at elevated temperature, they bond irreversibly forming a monolithic elastomeric substrate.

[0074] Elastomeric structures may be formed utilizing Sylgard 182, 184 or 186, or aliphatic urethane diacrylates such as (but not limited to) Ebecryl 270 or Irr 245 from UCB Chemical.

[0075] In one example, elastomeric structures were fabricated from pure acrylated Urethane Ebe 270. A thin bottom layer was spin coated at 8000 rpm for 15 seconds at 170°C. The top and bottom layers were initially cured under ultraviolet light for 10 minutes under nitrogen utilizing a Model ELC 500 device manufactured by Electrolite corporation. The assembled layers were then cured for an additional 30 minutes. Reaction was catalyzed by a 0.5% vol/vol mixture of Irgacure 500 manufactured by Ciba-Geigy Chemicals. The resulting elas-

tomeric material exhibited moderate elasticity and adhesion to glass.

[0076] In another example, two-layer elastomeric structures were fabricated from a combination of 25% Ebe 270 / 50% Irr245 / 25% isopropyl alcohol for a thin bottom layer, and pure acrylated Urethane Ebe 270 as a top layer. The thin bottom layer was initially cured for 5 min, and the top layer initially cured for 10 minutes, under ultraviolet light under nitrogen utilizing a Model ELC 500 device manufactured by Electrolite corporation. The assembled layers were then cured for an additional 30 minutes. Reaction was catalyzed by a 0.5% vol/vol mixture of Irgacure 500 manufactured by Ciba-Geigy Chemicals. The resulting elastomeric material exhibited moderate elasticity and adhered to glass.

[0077] Alternatively, other bonding methods may be used, including activating the elastomer surface, for example by plasma exposure, so that the elastomer layers/substrate will bond when placed in contact. For example, one possible approach to bonding together elastomer layers composed of the same material is set forth by Duffy et al, "Rapid Prototyping of Microfluidic Systems in Poly (dimethylsiloxane)", *Analytical Chemistry* (1998), 70, 4974-4984, incorporated herein by reference. This paper discusses that exposing polydimethylsiloxane (PDMS) layers to oxygen plasma causes oxidation of the surface, with irreversible bonding occurring when the two oxidized layers are placed into contact.

[0078] Yet another approach to bonding together successive layers of elastomer is to utilize the adhesive properties of uncured elastomer. Specifically, a thin layer of uncured elastomer such as RTV 615 is applied on top of a first cured elastomeric layer. Next, a second cured elastomeric layer is placed on top of the uncured elastomeric layer. The thin middle layer of uncured elastomer is then cured to produce a monolithic elastomeric structure. Alternatively, uncured elastomer can be applied to the bottom of a first cured elastomer layer, with the first cured elastomer layer placed on top of a second cured elastomer layer. Curing the middle thin elastomer layer again results in formation of a monolithic elastomeric structure.

[0079] Where encapsulation of sacrificial layers is employed to fabricate the elastomer structure as described above in Figs. 8-18, bonding of successive elastomeric layers may be accomplished by pouring uncured elastomer over a previously cured elastomeric layer and any sacrificial material patterned thereupon. Bonding between elastomer layers occurs due to interpenetration and reaction of the polymer chains of an uncured elastomer layer with the polymer chains of a cured elastomer layer. Subsequent curing of the elastomeric layer will create a bond between the elastomeric layers and create a monolithic elastomeric structure.

[0080] Referring to the first method of Figs. 1 to 7B, first elastomeric layer 20 may be created by spin-coating an RTV mixture on microfabricated mold 12 at 2000

rpm's for 30 seconds yielding a thickness of approximately 40 microns. Second elastomeric layer 22 may be created by spin-coating an RTV mixture on microfabricated mold 11. Both layers 20 and 22 may be separately baked or cured at about 80°C for 1.5 hours. The second elastomeric layer 22 may be bonded onto first elastomeric layer 20 at about 80°C for about 1.5 hours.

[0081] Micromachined molds 10 and 12 may be patterned photoresist on silicon wafers. In an exemplary aspect, a Shipley SJR 5740 photoresist was spun at 2000 rpm patterned with a high resolution transparency film as a mask and then developed yielding an inverse channel of approximately 10 microns in height. When baked at approximately 200°C for about 30 minutes, the photoresist reflows and the inverse channels become rounded. In preferred aspects, the molds may be treated with trimethylchlorosilane (TMCS) vapor for about a minute before each use in order to prevent adhesion of silicone rubber.

[0082] Using the various multilayer soft lithography construction techniques and materials set forth herein, the present inventors have experimentally succeeded in creating channel networks comprises of up to seven separate elastomeric layers thick, with each layer being about 40 μm thick. It is foreseeable that devices comprising more than seven separate elastomeric layers bonded together could be developed.

Suitable Elastomeric Materials:

[0083] Allcock et al, *Contemporary Polymer Chemistry*, 2nd Ed. describes elastomers in general as polymers existing at a temperature between their glass transition temperature and liquefaction temperature. Elastomeric materials exhibit elastic properties because the polymer chains readily undergo torsional motion to permit uncoiling of the backbone chains in response to a force, with the backbone chains recoiling to assume the prior shape in the absence of the force. In general, elastomers deform when force is applied, but then return to their original shape when the force is removed. The elasticity exhibited by elastomeric materials may be characterized by a Young's modulus. Elastomeric materials having a Young's modulus of between about 1 Pa - 1 TPa, more preferably between about 10 Pa - 100 GPa, more preferably between about 20 Pa - 1 GPa, more preferably between about 50 Pa - 10 MPa, and more preferably between about 100 Pa - 1 MPa are useful in accordance with the present invention, although elastomeric materials having a Young's modulus outside of these ranges could also be utilized depending upon the needs of a particular application.

[0084] The systems of the present invention may be fabricated from a wide variety of elastomers. In an exemplary aspect, elastomeric layers 20, 22, 42, 46 and 50 may preferably be fabricated from silicone rubber. However, other suitable elastomers may also be used.

[0085] In an exemplary aspect of the present inven-

tion, the present systems are fabricated from an elastomeric polymer such as GE RTV 615 (formulation), a vinylsilane crosslinked (type) silicone elastomer (family). However, the present systems are not limited to this one formulation, type or even this family of polymer; rather, nearly any elastomeric polymer is suitable. An important requirement for the preferred method of fabrication of the present microvalves is the ability to bond multiple layers of elastomers together. In the case of multilayer soft lithography, layers of elastomer are cured separately and then bonded together. This scheme requires that cured layers possess sufficient reactivity to bond together. Either the layers may be of the same type, and are capable of bonding to themselves, or they may be of two different types, and are capable of bonding to each other. Other possibilities include the use of an adhesive between layers and the use of thermoset elastomers.

[0086] Given the tremendous diversity of polymer chemistries, precursors, synthetic methods, reaction conditions, and potential additives, there are a huge number of possible elastomer systems that could be used to make monolithic elastomeric microvalves and pumps. Variations in the materials used will most likely be driven by the need for particular material properties, i.e. solvent resistance, stiffness, gas permeability, or temperature stability.

[0087] There are many, many types of elastomeric polymers. A brief description of the most common classes of elastomers is presented here, with the intent of showing that even with relatively "standard" polymers, many possibilities for bonding exist. Common elastomeric polymers include polyisoprene, polybutadiene, polychloroprene, polyisobutylene, poly(styrene-butadiene-styrene), the polyurethanes, and silicones.

Polyisoprene, polybutadiene, polychloroprene:

[0088] Polyisoprene, polybutadiene, and polychloroprene are all polymerized from diene monomers, and therefore have one double bond per monomer when polymerized. This double bond allows the polymers to be converted to elastomers by vulcanization (essentially, sulfur is used to form crosslinks between the double bonds by heating). This would easily allow homogeneous multilayer soft lithography by incomplete vulcanization of the layers to be bonded; photoresist encapsulation would be possible by a similar mechanism.

Polyisobutylene:

[0089] Pure polyisobutylene has no double bonds, but is crosslinked to use as an elastomer by including a small amount (~1%) of isoprene in the polymerization. The isoprene monomers give pendant double bonds on the polyisobutylene backbone, which may then be vulcanized as above.

Poly(styrene-butadiene-styrene):

[0090] Poly(styrene-butadiene-styrene) is produced by living anionic polymerization (that is, there is no natural chain-terminating step in the reaction), so "live" polymer ends can exist in the cured polymer. This makes it a natural candidate for the present photoresist encapsulation system (where there will be plenty of unreacted monomer in the liquid layer poured on top of the cured layer). Incomplete curing would allow homogeneous multilayer soft lithography (A to A bonding). The chemistry also facilitates making one layer with extra butadiene ("A") and coupling agent and the other layer ("B") with a butadiene deficit (for *heterogeneous* multilayer soft lithography). SBS is a "thermoset elastomer", meaning that above a certain temperature it melts and becomes plastic (as opposed to elastic); reducing the temperature yields the elastomer again. Thus, layers can be bonded together by heating.

Polyurethanes:

[0091] Polyurethanes are produced from di-isocyanates (A-A) and di-alcohols or diamines (B-B); since there are a large variety of di-isocyanates and di-alcohols/amines, the number of different types of polyurethanes is huge. The A vs. B nature of the polymers, however, would make them useful for heterogeneous multilayer soft lithography just as RTV 615 is: by using excess A-A in one layer and excess B-B in the other layer.

Silicones:

[0092] Silicone polymers probably have the greatest structural variety, and almost certainly have the greatest number of commercially available formulations. The vinyl-to-(Si-H) crosslinking of RTV 615 (which allows both heterogeneous multilayer soft lithography and photoresist encapsulation) has already been discussed, but this is only one of several crosslinking methods used in silicone polymer chemistry.

Cross Linking Agents:

[0093] In addition to the use of the simple "pure" polymers discussed above, crosslinking agents may be added. Some agents (like the monomers bearing pendant double bonds for vulcanization) are suitable for allowing homogeneous (A to A) multilayer soft lithography or photoresist encapsulation; in such an approach the same agent is incorporated into both elastomer layers. Complementary agents (i.e. one monomer bearing a pendant double bond, and another bearing a pendant Si-H group) are suitable for heterogeneous (A to B) multilayer soft lithography. In this approach complementary agents are added to adjacent layers.

Other Materials:

[0094] In addition, polymers incorporating materials such as chlorosilanes or methyl-, ethyl-, and phenylsilanes, and polydimethylsiloxane (PDMS) such as Dow Chemical Corp. Sylgard 182, 184 or 186, or aliphatic urethane diacrylates such as (but not limited to) Ebecryl 270 or Irr 245 from UCB Chemical may also be used.

[0095] The following is a non-exclusive list of elastomeric materials which may be utilized in connection with the present invention: polyisoprene, polybutadiene, polychloroprene, polyisobutylene, poly(styrene-butadiene-styrene), the polyurethanes, and silicone polymers; or poly(bis(fluoroalkoxy)phosphazene) (PNF, Eypel-F), poly(carborane-siloxanes) (Dexsil), poly(acrylonitrile-butadiene) (nitrile rubber), poly(1-butene), poly(chlorotrifluoroethylene-vinylidene fluoride) copolymers (Kel-F), poly(ethyl vinyl ether), poly(vinylidene fluoride), poly(vinylidene fluoride - hexafluoropropylene) copolymer (Viton), elastomeric compositions of polyvinylchloride (PVC), polysulfone, polycarbonate, polymethylmethacrylate (PMMA), and polytetrafluoroethylene (Teflon).

Doping and Dilution:

[0096] Elastomers may also be "doped" with uncrosslinkable polymer chains of the same class. For instance RTV 615 may be diluted with GE SF96-50 Silicone Fluid. This serves to reduce the viscosity of the uncured elastomer and reduces the Young's modulus of the cured elastomer. Essentially, the crosslink-capable polymer chains are spread further apart by the addition of "inert" polymer chains, so this is called "dilution". RTV 615 cures at up to 90% dilution, with a dramatic reduction in Young's modulus.

[0097] Fig. 49 plots Young's modulus versus percentage dilution with GE SF96-50 diluent of GE RTV 615 elastomer having a ratio of 30:1 A:B. FIG. 49 shows that the flexibility of the elastomer material, and hence the responsiveness of the valve membrane to an applied actuation force, can be controlled during fabrication of the device.

[0098] Other examples of doping of elastomer material may include the introduction of electrically conducting or magnetic species, as described in detail below in conjunction with alternative methods of actuating the membrane of the device. Should it be desired, doping with fine particles of material having an index of refraction different than the elastomeric material (i.e. silica, diamond, sapphire) is also contemplated as a system for altering the refractive index of the material. Strongly absorbing or opaque particles may be added to render the elastomer colored or opaque to incident radiation. This may conceivably be beneficial in an optically addressable system.

[0099] Finally, by doping the elastomer with specific chemical species, these doped chemical species may be presented at the elastomer surface, thus serving as

anchors or starting points for further chemical derivitization.

Pre-Treatment and Surface Coating

[0100] Once the elastomeric material has been molded or etched into the appropriate shape, it may be necessary to pre-treat the material in order to facilitate operation in connection with a particular application.

[0101] For example, one possible application for an elastomeric device in accordance with the present invention is to sort biological entities such as cells or DNA. In such an application, the hydrophobic nature of the biological entity may cause it to adhere to the hydrophobic elastomer of the walls of the channel. Therefore, it may be useful to pre-treat the elastomeric structure order to impart a hydrophilic character to the channel walls. In an embodiment of the present invention utilizing the General Electric RTV 615 elastomer, this can be accomplished by boiling the shaped elastomer in acid (e.g. 0.01% HCl in water, pH 2.7, at 60°C for 40 min).

[0102] Other types of pre-treatment of elastomer material are also contemplated by the present application. For example, certain portions of elastomer may be pre-treated to create anchors for surface chemistry reactions (for example in the formation of peptide chains), or binding sites for antibodies, as would be advantageous in a given application. Other examples of pre-treatment of elastomer material may include the introduction of reflective material on the elastomer surface, as described in detail below in conjunction with the micro-mirror array application.

Methods of Operating the Present Invention:

[0103] Figs. 7B and 7H together show the closing of a first flow channel by pressurizing a second flow channel, with Fig. 7B (a front sectional view cutting through flow channel 32 in corresponding Fig. 7A), showing an open first flow channel 30; with Fig. 7H showing first flow channel 30 closed by pressurization of the second flow channel 32.

[0104] Referring to Fig. 7B, first flow channel 30 and second flow channel 32 are shown. Membrane 25 separates the flow channels, forming the top of first flow channel 30 and the bottom of second flow channel 32. As can be seen, flow channel 30 is "open".

[0105] As can be seen in Fig. 7H, pressurization of flow channel 32 (either by gas or liquid introduced therein) causes membrane 25 to deflect downward, thereby pinching off flow F passing through flow channel 30. Accordingly, by varying the pressure in channel 32, a linearly actuatable valving system is provided such that flow channel 30 can be opened or closed by moving membrane 25 as desired. (For illustration purposes only, channel 30 in Fig. 7G is shown in a "mostly closed" position, rather than a "fully closed" position).

[0106] It is to be understood that exactly the same

valve opening and closing methods can be achieved with flow channels 60 and 62.

Since such valves are actuated by moving the roof of the channels themselves (i.e.: moving membrane 25) valves and pumps produced by this technique have a truly zero dead volume, and switching valves made by this technique have a dead volume approximately equal to the active volume of the valve, for example about $100 \times 100 \times 10 \mu\text{m} = 100\text{pL}$. Such dead volumes and areas consumed by the moving membrane are approximately two orders of magnitude smaller than known conventional microvalves. Smaller and larger valves and switching valves are contemplated in the present invention, and a non-exclusive list of ranges of dead volume includes 1 aL to 1 uL, 100 aL to 100 nL, 1 fL to 10 nL, 100 fL to 1 nL, and 1 pL to 100 pL.

[0107] The extremely small volumes capable of being delivered by pumps and valves in accordance with the present invention represent a substantial advantage. Specifically, the smallest known volumes of fluid capable of being manually metered is around 0.1 μl . The smallest known volumes capable of being metered by automated systems is about ten-times larger (1 μl). Utilizing pumps and valves in accordance with the present invention, volumes of liquid of 10 nl or smaller can routinely be metered and dispensed. The accurate metering of extremely small volumes of fluid enabled by the present invention would be extremely valuable in a large number of biological applications, including diagnostic tests and assays.

[0108] Equation 1 represents a highly simplified mathematical model of deflection of a rectangular, linear, elastic, isotropic plate of uniform thickness by an applied pressure:

$$(1) \quad w = (BPb^4)/(Eh^3),$$

where:

w = deflection of plate;
 B = shape coefficient (dependent upon length vs. width and support of edges of plate);
 P = applied pressure;
 b = plate width
 E = Young's modulus; and
 h = plate thickness.

[0109] Thus even in this extremely simplified expression, deflection of an elastomeric membrane in response to a pressure will be a function of: the length, width, and thickness of the membrane, the flexibility of the membrane (Young's modulus), and the applied actuation force. Because each of these parameters will vary widely depending upon the actual dimensions and physical composition of a particular elastomeric device in accordance with the present invention, a wide range of membrane thicknesses and elasticities, channel

widths, and actuation forces are contemplated by the present invention.

[0110] It should be understood that the formula just presented is only an approximation, since in general the membrane does not have uniform thickness, the membrane thickness is not necessarily small compared to the length and width, and the deflection is not necessarily small compared to length, width, or thickness of the membrane. Nevertheless, the equation serves as a useful guide for adjusting variable parameters to achieve a desired response of deflection versus applied force.

[0111] Figs. 21a and 21b illustrate valve opening vs. applied pressure for a 100 μm wide first flow channel 30 and a 50 μm wide second flow channel 32. The membrane of this device was formed by a layer of General Electric Silicones RTV 615 having a thickness of approximately 30 μm and a Young's modulus of approximately 750 kPa. Figs. 21a and 21b show the extent of opening of the valve to be substantially linear over most of the range of applied pressures. While the present invention does not require this linear actuation behavior, embodiments of the invention <insert here>.

[0112] Air pressure was applied to actuate the membrane of the device through a 10 cm long piece of plastic tubing having an outer diameter of 0.025" connected to a 25 mm piece of stainless steel hypodermic tubing with an outer diameter of 0.025" and an inner diameter of 0.013". This tubing was placed into contact with the control channel by insertion into the elastomeric block in a direction normal to the control channel. Air pressure was applied to the hypodermic tubing from an external LHDA miniature solenoid valve manufactured by Lee Co.

[0113] Connection of conventional microfluidic devices to an external fluid flow poses a number of problems avoided by the external configuration just described. One such problem is the fragility of their connections with the external environment. Specifically, conventional microfluidic devices are composed of hard, inflexible materials (such as silicon), to which pipes or tubing allowing connection to external elements must be joined. The rigidity of the conventional material creates significant physical stress at points of contact with small and delicate external tubing, rendering conventional microfluidic devices prone to fracture and leakage at these contact points.

[0114] By contrast, the elastomer of the present invention is flexible and can be easily penetrated for external connection by a tube composed a hard material. For example, in an elastomer structure fabricated utilizing the method shown in Figs. 1-7B, a hole extending from the exterior surface of the structure into the control channel can be made by penetrating the elastomer with metal hypodermic tubing after the upper elastomer piece has been removed from the mold (as shown in Fig. 3) and before this piece has been bonded to the lower elastomer piece (as shown in Fig. 4). Between these steps, the roof of the control channel is exposed to the user's view and is accessible to insertion and

proper positioning of the hole. Following completion of fabrication of the device, the metal hypodermic tubing is inserted into the hole to complete the fluid connection.

[0115] Moreover, the elastomer of the present invention will flex in response to physical strain at the point of contact with an external connection, rendering the external physical connection more robust. This flexibility substantially reduces the chance of leakage or fracture of the present device.

[0116] Another disadvantage of conventional microfluidic devices is the difficulty in establishing an effective seal between the device and its external links. Because of the extremely narrow diameter of the channels of these devices, even moderate rates of fluid flow can require extremely high pressures. Unwanted leakage at the junction between the device and external connections may result. However, the flexibility of the elastomer of the present device also aids in overcoming leakage relating to pressure. In particular, the flexible elastomeric material flexes to conform around inserted tubing in order to form a pressure resistant seal.

[0117] While control of the flow of material through the device has so far been described utilizing applied gas pressure, other fluids could be used. For example, air is compressible, and thus experiences some finite delay between the time of application of pressure by the external solenoid valve and the time that this pressure is experienced by the membrane. In an alternative embodiment of the present invention, pressure could be applied from an external source to a noncompressible fluid such as water or hydraulic oils, resulting in a near-instantaneous transfer of applied pressure to the membrane. However, if the displaced volume of the valve is large or the control channel is narrow, higher viscosity of a control fluid may contribute to delay in actuation. The optimal medium for transferring pressure will therefore depend upon the particular application and device configuration, and both gaseous and liquid media are contemplated by the invention.

[0118] While external applied pressure as described above has been applied by a pump/tank system through a pressure regulator and external miniature valve, other methods of applying external pressure are also contemplated in the present invention, including gas tanks, compressors, piston systems, and columns of liquid. Also contemplated is the use of naturally occurring pressure sources such as may be found inside living organisms, such as blood pressure, gastric pressure, the pressure present in the cerebro-spinal fluid, pressure present in the intra-ocular space, and the pressure exerted by muscles during normal flexure. Other methods of regulating external pressure are also contemplated, such as miniature valves, pumps, macroscopic peristaltic pumps, pinch valves, and other types of fluid regulating equipment such as is known in the art.

[0119] As can be seen, the response of valves in accordance with embodiments of the present invention have been experimentally shown to be almost perfectly

linear over a large portion of its range of travel, with minimal hysteresis. Accordingly, the present valves are ideally suited for microfluidic metering and fluid control. The linearity of the valve response demonstrates that the individual valves are well modeled as Hooke's Law springs. Furthermore, high pressures in the flow channel (i.e.: back pressure) can be countered simply by increasing the actuation pressure. Experimentally, the present inventors have achieved valve closure at back pressures of 70 kPa, but higher pressures are also contemplated. The following is a nonexclusive list of pressure ranges encompassed by the present invention: 10 Pa - 25 MPa; 100 Pa - 10 Mpa, 1 kPa - 1 MPa, 1 kPa - 300 kPa, 5 kPa-200 kPa, and 15 kPa - 100 kPa.

[0120] While valves and pumps do not require linear actuation to open and close, linear response does allow valves to more easily be used as metering devices. In one embodiment of the invention, the opening of the valve is used to control flow rate by being partially actuated to a known degree of closure. Linear valve actuation makes it easier to determine the amount of actuation force required to close the valve to a desired degree of closure. Another benefit of linear actuation is that the force required for valve actuation may be easily determined from the pressure in the flow channel. If actuation is linear, increased pressure in the flow channel may be countered by adding the same pressure (force per unit area) to the actuated portion of the valve.

[0121] Linearity of a valve depends on the structure, composition, and method of actuation of the valve structure. Furthermore, whether linearity is a desirable characteristic in a valve depends on the application. Therefore, both linearly and nonlinearly actuatable valves are contemplated in the present invention, and the pressure ranges over which a valve is linearly actuatable will vary with the specific embodiment.

[0122] Fig. 22 illustrates time response (i.e.: closure of valve as a function of time in response to a change in applied pressure) of a $100\mu\text{m} \times 100\mu\text{m} \times 10\mu\text{m}$ RTV microvalve with 10-cm-long air tubing connected from the chip to a pneumatic valve as described above.

[0123] Two periods of digital control signal, actual air pressure at the end of the tubing and valve opening are shown in Fig. 22. The pressure applied on the control line is 100 kPa, which is substantially higher than the -40 kPa required to close the valve. Thus, when closing, the valve is pushed closed with a pressure 60 kPa greater than required. When opening, however; the valve is driven back to its rest position only by its own spring force (≤ 40 kPa). Thus, τ_{close} is expected to be smaller than τ_{open} . There is also a lag between the control signal and control pressure response, due to the limitations of the miniature valve used to control the pressure. Calling such lags t and the $1/e$ time constants τ , the values are: $t_{\text{open}} = 3.63$ ms, $\tau_{\text{open}} = 1.88$ ms, $t_{\text{close}} = 2.15$ ms, $\tau_{\text{close}} = 0.51$ ms. If 3τ each are allowed for opening and closing, the valve runs comfortably at 75 Hz when filled with aqueous solution.

[0124] If one used another actuation method which did not suffer from opening and closing lag, this valve would run at ~375 Hz. Note also that the spring constant can be adjusted by changing the membrane thickness; this allows optimization for either fast opening or fast closing. The spring constant could also be adjusted by changing the elasticity (Young's modulus) of the membrane, as is possible by introducing dopant into the membrane or by utilizing a different elastomeric material to serve as the membrane (described above in conjunction with Figs. 7C-7H.)

[0125] When experimentally measuring the valve properties as illustrated in Figs. 21 and 22, the valve opening was measured by fluorescence. In these experiments, the flow channel was filled with a solution of fluorescein isothiocyanate (FITC) in buffer (pH \geq 8) and the fluorescence of a square area occupying the center ~1/3rd of the channel is monitored on an epi-fluorescence microscope with a photomultiplier tube with a 10 kHz bandwidth. The pressure was monitored with a Wheatstone-bridge pressure sensor (SenSym SCC15GD2) pressurized simultaneously with the control line through nearly identical pneumatic connections.

Flow Channel Cross Sections:

[0126] The flow channels of the present invention may optionally be designed with different cross sectional sizes and shapes, offering different advantages, depending upon their desired application. For example, the cross sectional shape of the lower flow channel may have a curved upper surface, either along its entire length or in the region disposed under an upper cross channel). Such a curved upper surface facilitates valve sealing, as follows.

[0127] Referring to Fig. 19, a cross sectional view (similar to that of Fig. 7B) through flow channels 30 and 32 is shown. As can be seen, flow channel 30 is rectangular in cross sectional shape. In an alternate preferred aspect of the invention, as shown in Fig. 20, the cross-section of a flow channel 30 instead has an upper curved surface.

[0128] Referring first to Fig. 19, when flow channel 32 is pressurized, the membrane portion 25 of elastomeric block 24 separating flow channels 30 and 32 will move downwardly to the successive positions shown by the dotted lines 25A, 25B, 25C, 25D, and 25E. As can be seen, incomplete sealing may possibly result at the edges of flow channel 30 adjacent planar substrate 14.

[0129] In the alternate preferred embodiment of Fig. 20, flow channel 30a has a curved upper wall 25A. When flow channel 32 is pressurized, membrane portion 25 will move downwardly to the successive positions shown by dotted lines 25A2, 25A3, 25A4 and 25A5, with edge portions of the membrane moving first into the flow channel, followed by top membrane portions. An advantage of having such a curved upper surface at membrane 25A is that a more complete seal will be provided

when flow channel 32 is pressurized. Specifically, the upper wall of the flow channel 30 will provide a continuous contacting edge against planar substrate 14, thereby avoiding the "island" of contact seen between wall 25 and the bottom of flow channel 30 in Fig. 19.

[0130] Another advantage of having a curved upper flow channel surface at membrane 25A is that the membrane can more readily conform to the shape and volume of the flow channel in response to actuation. Specifically, where a rectangular flow channel is employed, the entire perimeter (2x flow channel height, plus the flow channel width) must be forced into the flow channel. However where an arched flow channel is used, a smaller perimeter of material (only the semi-circular arched portion) must be forced into the channel. In this manner, the membrane requires less change in perimeter for actuation and is therefore more responsive to an applied actuation force to block the flow channel

[0131] In an alternate aspect, (not illustrated), the bottom of flow channel 30 is rounded such that its curved surface mates with the curved upper wall 25A as seen in Fig. 20 described above.

[0132] In summary, the actual conformational change experienced by the membrane upon actuation will depend upon the configuration of the particular elastomeric structure. Specifically, the conformational change will depend upon the length, width, and thickness profile of the membrane, its attachment to the remainder of the structure, and the height, width, and shape of the flow and control channels and the material properties of the elastomer used. The conformational change may also depend upon the method of actuation, as actuation of the membrane in response to an applied pressure will vary somewhat from actuation in response to a magnetic or electrostatic force.

[0133] Moreover, the desired conformational change in the membrane will also vary depending upon the particular application for the elastomeric structure. In the simplest embodiments described above, the valve may either be open or closed, with metering to control the degree of closure of the valve. In other embodiments however, it may be desirable to alter the shape of the membrane and/or the flow channel in order to achieve more complex flow regulation. For instance, the flow channel could be provided with raised protrusions beneath the membrane portion, such that upon actuation the membrane shuts off only a percentage of the flow through the flow channel, with the percentage of flow blocked insensitive to the applied actuation force.

[0134] Many membrane thickness profiles and flow channel cross-sections are contemplated by the present invention, including rectangular, trapezoidal, circular, ellipsoidal, parabolic, hyperbolic, and polygonal, as well as sections of the above shapes. More complex cross-sectional shapes, such as the embodiment with protrusions discussed immediately above or an embodiment having concavities in the flow channel, are also contemplated by the present invention.

Alternate Valve Actuation Techniques:

[0135] In addition to pressure based actuation systems described above, optional electrostatic and magnetic actuation systems are also contemplated, as follows.

[0136] Electrostatic actuation can be accomplished by forming oppositely charged electrodes (which will tend to attract one another when a voltage differential is applied to them) directly into the monolithic elastomeric structure. For example, referring to Fig. 7B, an optional first electrode 70 (shown in phantom) can be positioned on (or in) membrane 25 and an optional second electrode 72 (also shown in phantom) can be positioned on (or in) planar substrate 14. When electrodes 70 and 72 are charged with opposite polarities, an attractive force between the two electrodes will cause membrane 25 to deflect downwardly, thereby closing the "valve" (i.e.: closing flow channel 30).

[0137] For the membrane electrode to be sufficiently conductive to support electrostatic actuation, but not so mechanically stiff so as to impede the valve's motion, a sufficiently flexible electrode must be provided in or over membrane 25. Such an electrode may be provided by a thin metallization layer, doping the polymer with conductive material, or making the surface layer out of a conductive material.

[0138] In an exemplary aspect, the electrode present at the deflecting membrane can be provided by a thin metallization layer which can be provided, for example, by sputtering a thin layer of metal such as 20 nm of gold. In addition to the formation of a metallized membrane by sputtering, other metallization approaches such as chemical epitaxy, evaporation, electroplating, and electroless plating are also available. Physical transfer of a metal layer to the surface of the elastomer is also available, for example by evaporating a metal onto a flat substrate to which it adheres poorly, and then placing the elastomer onto the metal and peeling the metal off of the substrate.

[0139] A conductive electrode 70 may also be formed by depositing carbon black (i.e. Cabot Vulcan XC72R) on the elastomer surface, either by wiping on the dry powder or by exposing the elastomer to a suspension of carbon black in a solvent which causes swelling of the elastomer, (such as a chlorinated solvent in the case of PDMS). Alternatively, the electrode 70 may be formed by constructing the entire layer 20 out of elastomer doped with conductive material (i.e. carbon black or finely divided metal particles). Yet further alternatively, the electrode may be formed by electrostatic deposition, or by a chemical reaction that produces carbon. In experiments conducted by the present inventors, conductivity was shown to increase with carbon black concentration from 5.6×10^{-16} to about $5 \times 10^{-3} (\Omega\text{-cm})^{-1}$. The lower electrode 72, which is not required to move, may be either a compliant electrode as described above, or a conventional electrode such as evaporated gold, a metal

plate, or a doped semiconductor electrode.

[0140] Alternatively, magnetic actuation of the flow channels can be achieved by fabricating the membrane separating the flow channels with a magnetically polarizable material such as iron, or a permanently magnetized material such as polarized NdFeB. In experiments conducted by the present inventors, magnetic silicone was created by the addition of iron powder (about 1 μm particle size), up to 20% iron by weight.

[0141] Where the membrane is fabricated with a magnetically polarizable material, the membrane can be actuated by attraction in response to an applied magnetic field. Where the membrane is fabricated with a material capable of maintaining permanent magnetization, the material can first be magnetized by exposure to a sufficiently high magnetic field, and then actuated either by attraction or repulsion in response to the polarity of an applied inhomogeneous magnetic field.

[0142] The magnetic field causing actuation of the membrane can be generated in a variety of ways. In one embodiment, the magnetic field is generated by an extremely small inductive coil formed in or proximate to the elastomer membrane. The actuation effect of such a magnetic coil would be localized, allowing actuation of individual pump and/or valve structures. Alternatively, the magnetic field could be generated by a larger, more powerful source, in which case actuation would be global and would actuate multiple pump and/or valve structures at one time.

[0143] It is further possible to combine pressure actuation with electrostatic or magnetic actuation. Specifically, a bellows structure in fluid communication with a recess could be electrostatically or magnetically actuated to change the pressure in the recess and thereby actuate a membrane structure adjacent to the recess.

[0144] In addition to electrical or magnetic actuation as described above, optional electrolytic and electrokinetic actuation systems are also contemplated by the present invention. For example, actuation pressure on the membrane could arise from an electrolytic reaction in a recess overlying the membrane. In such an embodiment, electrodes present in the recess would apply a voltage across an electrolyte in the recess. This potential difference would cause electrochemical reaction at the electrodes and result in the generation of gas species, giving rise to a pressure differential in the recess.

[0145] Alternatively, actuation pressure on the membrane could arise from an electrokinetic fluid flow in the control channel. In such an embodiment, electrodes present at opposite ends of the control channel would apply a potential difference across an electrolyte present in the control channel. Migration of charged species in the electrolyte to the respective electrodes could give rise to a pressure differential.

[0146] Finally, it is also possible to actuate the device by causing a fluid flow in the control channel based upon the application of thermal energy, either by thermal expansion or by production of gas from liquid. Similarly,

chemical reactions generating gaseous products may produce an increase in pressure sufficient for membrane actuation.

Networked Systems:

[0147] Figs. 23A and 23B show a views of a single on/off valve, identical to the systems set forth above, (for example in Fig. 7A). Figs. 24A and 24B shows a peristaltic pumping system comprised of a plurality of the single addressable on/off valves as seen in Fig. 23, but networked together. Fig. 25 is a graph showing experimentally achieved pumping rates vs. frequency for the peristaltic pumping system of Fig. 24. Figs. 26A and 26B show a schematic view of a plurality of flow channels which are controllable by a single control line. This system is also comprised of a plurality of the single addressable on/off valves of Fig. 23, multiplexed together, but in a different arrangement than that of Fig. 23. Fig. 27 is a schematic illustration of a multiplexing system according to the invention, adapted to permit fluid flow through selected channels, comprised of a plurality of the single on/off valves of Fig. 23, joined or networked together.

[0148] Referring first to Figs. 23A and 23B, a schematic of flow channels 30 and 32 is shown. Flow channel 30 preferably has a fluid (or gas) flow F passing there-through. Flow channel 32, (which crosses over flow channel 30, as was already explained herein), is pressurized such that membrane 25 separating the flow channels may be depressed into the path of flow channel 30, shutting off the passage of flow F therethrough, as has been explained. As such, "flow channel" 32 can also be referred to as a "control line" which actuates a single valve in flow channel 30. In Figs. 23 to 26, a plurality of such addressable valves are joined or networked together in various arrangements to produce pumps, capable of peristaltic pumping, and other fluidic logic applications.

[0149] Referring to Fig. 24A and 24B, a system for peristaltic pumping is provided, as follows. A flow channel 30 has a plurality of generally parallel flow channels (i.e.: control lines) 32A, 32B and 32C passing thereover. By pressurizing control line 32A, flow F through flow channel 30 is shut off under membrane 25A at the intersection of control line 32A and flow channel 30. Similarly, (but not shown), by pressurizing control line 32B, flow F through flow channel 30 is shut off under membrane 25B at the intersection of control line 32B and flow channel 30, etc.

[0150] Each of control lines 32A, 32B, and 32C is separately addressable. Therefore, peristalsis may be actuated by the pattern of actuating 32A and 32C together, followed by 32A, followed by 32A and 32B together, followed by 32B, followed by 32B and C together, etc. This corresponds to a successive "101, 100, 110, 010, 011, 001" pattern, where "0" indicates "valve open" and "1" indicates "valve closed." This peristaltic pattern is also

known as a 120° pattern (referring to the phase angle of actuation between three valves). Other peristaltic patterns are equally possible, including 60° and 90° patterns.

[0151] In experiments performed by the inventors, a pumping rate of 2.35 nL/s was measured by measuring the distance traveled by a column of water in thin (0.5 mm i.d.) tubing; with 100x100x10 μm valves under an actuation pressure of 40 kPa. The pumping rate increased with actuation frequency until approximately 75 Hz, and then was nearly constant until above 200 Hz. The valves and pumps are also quite durable and the elastomer membrane, control channels, or bond have never been observed to fail. In experiments performed by the inventors, none of the valves in the peristaltic pump described herein show any sign of wear or fatigue after more than 4 million actuations. In addition to their durability, they are also gentle. A solution of *E. Coli* pumped through a channel and tested for viability showed a 94% survival rate.

[0152] Fig. 25 is a graph showing experimentally achieved pumping rates vs. frequency for the peristaltic pumping system of Fig. 24.

[0153] Figs. 26A and 26B illustrates another way of assembling a plurality of the addressable valves of Fig. 21. Specifically, a plurality of parallel flow channels 30A, 30B, and 30C are provided. Flow channel (i.e.: control line) 32 passes thereover across flow channels 30A, 30B, and 30C. Pressurization of control line 32 simultaneously shuts off flows F1, F2 and F3 by depressing membranes 25A, 25B, and 25C located at the intersections of control line 32 and flow channels 30A, 30B, and 30C.

[0154] Fig. 27 is a schematic illustration of a multiplexing system according to the invention adapted to selectively permit fluid to flow through selected channels, as follows. The downward deflection of membranes separating the respective flow channels from a control line passing thereabove (for example, membranes 25A, 25B, and 25C in Figs. 26A and 26B) depends strongly upon the membrane dimensions. Accordingly, by varying the widths of flow channel control line 32 in Figs. 26A and 26B, it is possible to have a control line pass over multiple flow channels, yet only actuate (i.e.: seal) desired flow channels. Fig. 27 illustrates a schematic of such a system, as follows.

[0155] A plurality of parallel flow channels 30A, 30B, 30C, 30D, 30E and 30F are positioned under a plurality of parallel control lines 32A, 32B, 32C, 32D, 32E and 32F. Control channels 32A, 32B, 32C, 32D, 32E and 32F are adapted to shut off fluid flows F1, F2, F3, F4, F5 and F6 passing through parallel flow channels 30A, 30B, 30C, 30D, 30E and 30F using any of the valving systems described above, with the following modification.

[0156] Each of control lines 32A, 32B, 32C, 32D, 32E and 32F have both wide and narrow portions. For example, control line 32A is wide in locations disposed over flow channels 30A, 30C and 30E. Similarly, control

line 32B is wide in locations disposed over flow channels 30B, 30D and 30F, and control line 32C is wide in locations disposed over flow channels 30A, 30B, 30E and 30F.

[0157] At the locations where the respective control line is wide, its pressurization will cause the membrane (25) separating the flow channel and the control line to depress significantly into the flow channel, thereby blocking the flow passage therethrough. Conversely, in the locations where the respective control line is narrow, membrane (25) will also be narrow. Accordingly, the same degree of pressurization will not result in membrane (25) becoming depressed into the flow channel (30). Therefore, fluid passage thereunder will not be blocked.

[0158] For example, when control line 32A is pressurized, it will block flows F1, F3 and F5 in flow channels 30A, 30C and 30E. Similarly, when control line 32C is pressurized, it will block flows F1, F2, F5 and F6 in flow channels 30A, 30B, 30E and 30F. As can be appreciated, more than one control line can be actuated at the same time. For example, control lines 32A and 32C can be pressurized simultaneously to block all fluid flow except F4 (with 32A blocking F1, F3 and F5; and 32C blocking F1, F2, F5 and F6).

[0159] By selectively pressurizing different control lines (32) both together and in various sequences, a great degree of fluid flow control can be achieved. Moreover, by extending the present system to more than six parallel flow channels (30) and more than four parallel control lines (32), and by varying the positioning of the wide and narrow regions of the control lines, very complex fluid flow control systems may be fabricated. A property of such systems is that it is possible to turn on any one flow channel out of n flow channels with only 2 ($\log_2 n$) control lines.

[0160] The inventors have succeeded in fabricating microfluidic structures with densities of 30 devices /mm², but greater densities are achievable.

Selectively Addressable Reaction Chambers Along Flow Lines:

[0161] In a further embodiment of the invention, illustrated in Figs. 28A, 28B, 28C and 28D, a system for selectively directing fluid flow into one more of a plurality of reaction chambers disposed along a flow line is provided.

[0162] Fig. 28A shows a top view of a flow channel 30 having a plurality of reaction chambers 80A and 80B disposed therealong. Preferably flow channel 30 and reaction chambers 80A and 80B are formed together as recesses into the bottom surface of a first layer 100 of elastomer.

[0163] Fig. 28B shows a bottom plan view of another elastomeric layer 110 with two control lines 32A and 32B each being generally narrow, but having wide extending portions 33A and 33B formed as recesses therein.

[0164] As seen in the exploded view of Fig. 28C, and assembled view of Fig. 28D, elastomeric layer 110 is placed over elastomeric layer 100. Layers 100 and 110 are then bonded together, and the integrated system operates to selectively direct fluid flow F (through flow channel 30) into either or both of reaction chambers 80A and 80B, as follows. Pressurization of control line 32A will cause the membrane 25 (i.e.: the thin portion of elastomer layer 100 located below extending portion 33A and over regions 82A of reaction chamber 80A) to become depressed, thereby shutting off fluid flow passage in regions 82A, effectively sealing reaction chamber 80 from flow channel 30. As can also be seen, extending portion 33A is wider than the remainder of control line 32A. As such, pressurization of control line 32A will not result in control line 32A sealing flow channel 30.

[0165] As can be appreciated, either or both of control lines 32A and 32B can be actuated at once. When both control lines 32A and 32B are pressurized together, sample flow in flow channel 30 will enter neither of reaction chambers 80A or 80B.

[0166] The concept of selectably controlling fluid introduction into various addressable reaction chambers disposed along a flow line (Figs. 28) can be combined with concept of selectably controlling fluid flow through one or more of a plurality of parallel flow lines (Fig. 27) to yield a system in which a fluid sample or samples can be sent to any particular reaction chamber in an array of reaction chambers. An example of such a system is provided in Fig. 29, in which parallel control channels 32A, 32B and 32C with extending portions 34 (all shown in phantom) selectively direct fluid flows F1 and F2 into any of the array of reaction wells 80A, 80B, 80C or 80D as explained above; while pressurization of control lines 32C and 32D selectively shuts off flows F2 and F1, respectively.

[0167] In yet another novel embodiment, fluid passage between parallel flow channels is possible. Referring to Fig. 30, either or both of control lines 32A or 32D can be depressurized such that fluid flow through lateral passageways 35 (between parallel flow channels 30A and 30B) is permitted. In this aspect of the invention, pressurization of control lines 32C and 32D would shut flow channel 30A between 35A and 35B, and would also shut lateral passageways 35B. As such, flow entering as flow F1 would sequentially travel through 30A, 35A and leave 30B as flow F4.

Switchable Flow Arrays

[0168] In yet another novel embodiment, fluid passage can be selectively directed to flow in either of two perpendicular directions. An example of such a "switchable flow array" system is provided in Figs. 31A to 31D. Fig. 31A shows a bottom view of a first layer of elastomer 90, (or any other suitable substrate), having a bottom surface with a pattern of recesses forming a flow channel grid defined by an array of solid posts 92, each hav-

ing flow channels passing therearound.

[0169] In preferred aspects, an additional layer of elastomer is bound to the top surface of layer 90 such that fluid flow can be selectively directed to move either in direction F1, or perpendicular direction F2. Fig. 31 is a bottom view of the bottom surface of the second layer of elastomer 95 showing recesses formed in the shape of alternating "vertical" control lines 96 and "horizontal" control lines 94. "Vertical" control lines 96 have the same width therealong, whereas "horizontal" control lines 94 have alternating wide and narrow portions, as shown.

[0170] Elastomeric layer 95 is positioned over top of elastomeric layer 90 such that "vertical" control lines 96 are positioned over posts 92 as shown in Fig. 31C and "horizontal" control lines 94 are positioned with their wide portions between posts 92, as shown in Fig. 31D.

[0171] As can be seen in Fig. 31C, when "vertical" control lines 96 are pressurized, the membrane of the integrated structure formed by the elastomeric layer initially positioned between layers 90 and 95 in regions 98 will be deflected downwardly over the array of flow channels such that flow is only able to pass in flow direction F2 (i.e.: vertically), as shown.

[0172] As can be seen in Fig. 31D, when "horizontal" control lines 94 are pressurized, the membrane of the integrated structure formed by the elastomeric layer initially positioned between layers 90 and 95 in regions 99 will be deflected downwardly over the array of flow channels, (but only in the regions where they are widest), such that flow is only able to pass in flow direction F1 (i.e.: horizontally), as shown.

[0173] The design illustrated in Figs. 31 allows a switchable flow array to be constructed from only two elastomeric layers, with no vertical vias passing between control lines in different elastomeric layers required. If all vertical flow control lines 94 are connected, they may be pressurized from one input. The same is true for all horizontal flow control lines 96.

Biopolymer Synthesis

[0174] The present elastomeric valving structures can also be used in biopolymer synthesis, for example, in synthesizing oligonucleotides, proteins, peptides, DNA, etc. In a preferred aspect, such biopolymer synthesis systems may comprise an integrated system comprising an array of reservoirs, fluidic logic (according to the present invention) for selecting flow from a particular reservoir, an array of channels or reservoirs in which synthesis is performed, and fluidic logic (also according to the present invention) for determining into which channels the selected reagent flows. An example of such a system 200 is illustrated in Fig. 32, as follows.

[0175] Four reservoirs 150A, 150B, 150C and 150D have bases A, C, T and G respectively disposed therein, as shown. Four flow channels 30A, 30B, 30C and 30D are connected to reservoirs 150A, 150B, 150C and

150D. Four control lines 32A, 32B, 32C and 32D (shown in phantom) are disposed thereacross with control line 32A permitting flow only through flow channel 30A (i.e.: sealing flow channels 30B, 30C and 30D), when control line 32A is pressurized. Similarly, control line 32B permits flow only through flow channel 30B when pressurized. As such, the selective pressurization of control lines 32A, 32B, 32C and 32D sequentially selects a desired base A, C, T and G from a desired reservoir 150A, 150B, 150C or 150D. The fluid then passes through flow channel 120 into a multiplexed channel flow controller 125, (including, for example, any system as shown in Figs. 26A to 31D) which in turn directs fluid flow into one or more of a plurality of synthesis channels or chambers 122A, 122B, 122C, 122D or 122E in which solid phase synthesis may be carried out.

[0176] Fig. 33 shows a further extension of this system on which a plurality of reservoirs R1 to R13 (which may contain bases A, T, C and G, or any other reactants, such as would be used in combinatorial chemistry), are connected to systems 200 as set forth in Figs. 32. Systems 200 are connected to a multiplexed channel flow controller 125, (including, for example, any system as shown in Figs. 26A to 31D) which is in turn connected to a switchable flow array (for example as shown in Figs. 31). An advantage of this system is that both of multiplexed channel flow controllers 125 and fluid selection systems 200 can be controlled by the same pressure inputs 170 and 172, provided a "close horizontal" and a "close vertical" control lines (160 and 162, in phantom) are also provided.

[0177] In further alternate aspects of the invention, a plurality of multiplexed channel flow controllers (such as 125) may be used, with each flow controller initially positioned stacked above one another on a different elastomeric layer, with vertical vias or interconnects between the elastomer layers (which may be created by lithographically patterning an etch resistant layer on top of an elastomer layer, then etching the elastomer and finally removing the etch resist before adding the last layer of elastomer).

[0178] For example, a vertical via in an elastomer layer can be created by etching a hole down onto a raised line on a micromachined mold, and bonding the next layer such that a channel passes over that hole. In this aspect of the invention, multiple synthesis with a plurality of multiplexed channel flow controllers 125 is possible.

[0179] The bonding of successive layers of molded elastomer to form a multi-layer structure is shown in Fig. 34, which is an optical micrograph of a section of a test structure composed of seven layers of elastomer. The scale bar of Fig. 34 is 200 μm .

[0180] One method for fabricating an elastomer layer having the vertical via feature utilized in a multi-layer structure is shown in FIGS. 35A-35D. FIG. 35A shows formation of elastomer layer 3500 over micromachined mold 3502 including raised line 3502a.

[0181] FIG. 35B shows formation of metal etch block-

ing layer 3504 over elastomer layer 3500, followed by the patterning of photoresist mask 3506 over etch blocking layer 3504 to cover masked regions 3508 and leave exposed unmasked regions 3510. FIG. 35C shows the exposure to solvent which removes etch blocking layer 3504 in unmasked regions 3510.

[0182] FIG. 35D shows removal of the patterned photoresist, followed by subsequent etching of underlying elastomer 3500 in unmasked regions 3510 to form vertical via 3512. Subsequent exposure to solvent removes remaining etch blocking layer 3504 in masked regions 3508 selective to the surrounding elastomer 3500 and mold 3502. This elastomer layer may then be incorporated into an elastomer structure by multilayer soft lithography.

[0183] This series of steps can be repeated as necessary to form a multi-layered structure having the desired number and orientation of vertical vias between channels of successive elastomer layers.

[0184] The inventors of the present invention have succeeded in etching vias through GE RTV 615 layers using a solution of Tetrabutylammonium fluoride in organic solvent. Gold serves as the etch blocking material, with gold removed selective to GE RTV 615 utilizing a $KI/I_2/H_2O$ mixture.

[0185] Alternatively, vertical vias between channels in successive elastomer layers could be formed utilizing a negative mask technique. In this approach, a negative mask of a metal foil is patterned, and subsequent formation of an etch blocking layer is inhibited where the metal foil is present. Once the etch blocking material is patterned, the negative metal foil mask is removed, permitting selective etching of the elastomer as described above.

[0186] In yet another approach, vertical vias could be formed in an elastomer layer using ablation of elastomer material through application of radiation from an applied laser beam.

[0187] While the above approach is described in connection with the synthesis of biopolymers, the invention is not limited to this application. The present invention could also function in a wide variety of combinatorial chemical synthesis approaches.

Other Applications:

[0188] Advantageous applications of the present monolithic microfabricated elastomeric valves and pumps are numerous. Accordingly, the present invention is not limited to any particular application or use thereof. In preferred aspects, the following uses and applications for the present invention are contemplated.

1. Cell/DNA Sorting

[0189] The present microfluidic pumps and valves can also be used in flow cytometers for cell sorting and DNA sizing. Sorting of objects based upon size is ex-

tremely useful in many technical fields.

[0190] For example, many assays in biology require determination of the size of molecular-sized entities. Of particular importance is the measurement of length distribution of DNA molecules in a heterogeneous solution. This is commonly done using gel electrophoresis, in which the molecules are separated by their differing mobility in a gel matrix in an applied electric field, and their positions detected by absorption or emission of radiation. The lengths of the DNA molecules are then inferred from their mobility.

[0191] While powerful, electrophoretic methods pose disadvantages. For medium to large DNA molecules, resolution, i.e. the minimum length difference at which different molecular lengths may be distinguished, is limited to approximately 10% of the total length. For extremely large DNA molecules, the conventional sorting procedure is not workable. Moreover, gel electrophoresis is a relatively lengthy procedure, and may require on the order of hours or days to perform.

[0192] The sorting of cellular-sized entities is also an important task. Conventional flow cell sorters are designed to have a flow chamber with a nozzle and are based on the principle of hydrodynamic focusing with sheath flow. Most conventional cell sorters combine the technology of piezo-electric drop generation and electrostatic deflection to achieve droplet generation and high sorting rates. However, this approach offers some important disadvantages. One disadvantage is that the complexity, size, and expense of the sorting device requires that it be reusable in order to be cost-effective. Reuse can in turn lead to problems with residual materials causing contamination of samples and turbulent fluid flow.

[0193] Therefore, there is a need in the art for a simple, inexpensive, and easily fabricated sorting device which relies upon the mechanical control of fluid flow rather than upon electrical interactions between the particle and the solute.

[0194] FIG. 36 shows one embodiment of a sorting device in accordance with the present invention. Sorting device 3600 is formed from a switching valve structure created from channels present in an elastomeric block. Specifically, flow channel 3602 is T-shaped, with stem 3602a of flow channel 3602 in fluid communication with sample reservoir 3604 containing sortable entities 3606 of different types denoted by shape (square, circle, triangle, etc.). Left branch 3602b of flow channel 3602 is in fluid communication with waste reservoir 3608. Right branch 3602c of flow channel 3602 is in communication with collection reservoir 3610.

[0195] Control channels 3612a, 3612b, and 3612c overlie and are separated from stem 3602a of flow channel 3602 by elastomeric membrane portions 3614a, 3614b, and 3614c respectively. Together, stem 3602a of flow channel 3602 and control channels 3612a, 3612b, and 3612c form first peristaltic pump structure 3616 similar to that described at length above in con-

nection with FIG. 24a.

[0196] Control channel 3612d overlies and is separated from right branch 3602c of flow channel 3602 by elastomeric membrane portion 3614d. Together, right branch 3602c of flow channel 3602 and control channels 3612d forms first valve structure 3618a. Control channel 3612e overlies and is separated from left branch 3602c of flow channel 3602 by elastomeric membrane portion 3614e. Together, left branch 3602c of flow channel 3602 and control channel 3612e forms second valve structure 3618b.

[0197] As shown in FIG. 36, stem 3602a of flow channel 3602 narrows considerably as it approaches detection window 3620 adjacent to the junction of stem 3602a, right branch 3602b, and left branch 3602c. Detection window 3620 is of sufficient width to allow for uniform illumination of this region. In one embodiment, the width of the stem narrows from 100 μm to 5 μm at the detection window. The width of the stem at the detection window can be precisely formed using the soft lithography or photoresist encapsulation fabrication techniques described extensively above, and will be depend upon the nature and size of the entity to be sorted.

[0198] Operation of sorting device in accordance with one embodiment of the present invention is as follows.

[0199] The sample is diluted to a level such that only a single sortable entity would be expected to be present in the detection window at any time. Peristaltic pump 3616 is activated by flowing a fluid through control channels 3612a-c as described extensively above. In addition, second valve structure 3618b is closed by flowing fluid through control channel 3612e. As a result of the pumping action of peristaltic pump 3616 and the blocking action of second valve 3618b, fluid flows from sample reservoir 3604 through detection window 3620 into waste reservoir 3608. Because of the narrowing of stem 3604, sortable entities present in sample reservoir 3604 are carried by this regular fluid flow, one at a time, through detection window 3620.

[0200] Radiation 3640 from source 3642 is introduced into detection window 3620. This is possible due to the transmissive property of the elastomeric material. Absorption or emission of radiation 3640 by sortable entity 3606 is then detected by detector 3644.

[0201] If sortable entity 3606a within detection window 3620 is intended to be segregated and collected by sorting device 3600, first valve 3618a is activated and second valve 3618b is deactivated. This has the effect of drawing sortable entity 3606a into collection reservoir 3610, and at the same time transferring second sortable entity 3606b into detection window 3620. If second sortable entity 3602b is also identified for collection, peristaltic pump 3616 continues to flow fluid through right branch 3602c of flow channel 3602 into collection reservoir 3610. However, if second entity 3606b is not to be collected, first valve 3618a opens and second valve 3618b closes, and first peristaltic pump 3616 resumes pumping liquid through left branch 3602b of flow chan-

nel 3602 into waste reservoir 3608.

[0202] While one specific embodiment of a sorting device and a method for operation thereof is described in connection with FIG. 36, the present invention is not limited to this embodiment. For example, fluid need not be flowed through the flow channels using the peristaltic pump structure, but could instead be flowed under pressure with the elastomeric valves merely controlling the directionality of flow. In yet another embodiment, a plurality of sorting structures could be assembled in series in order to perform successive sorting operations, with the waste reservoir of FIG. 36 simply replaced by the stem of the next sorting structure.

[0203] Moreover, a high throughput method of sorting could be employed, wherein a continuous flow of fluid from the sample reservoir through the window and junction into the waste reservoir is maintained until an entity intended for collection is detected in the window. Upon detection of an entity to be collected, the direction of fluid flow by the pump structure is temporarily reversed in order to transport the desired particle back through the junction into the collection reservoir. In this manner, the sorting device could utilize a higher flow rate, with the ability to backtrack when a desired entity is detected. Such an alternative high throughput sorting technique could be used when the entity to be collected is rare, and the need to backtrack infrequent.

[0204] Sorting in accordance with the present invention would avoid the disadvantages of sorting utilizing conventional electrokinetic flow, such as bubble formation, a strong dependence of flow magnitude and direction on the composition of the solution and surface chemistry effects, a differential mobility of different chemical species, and decreased viability of living organisms in the mobile medium.

2. Semiconductor Processing

[0205] Systems for semiconductor gas flow control, (particularly for epitaxial applications in which small quantities of gases are accurately metered), are also contemplated by the present invention. For example, during fabrication of semiconductor devices solid material is deposited on top of a semiconductor substrate utilizing chemical vapor deposition (CVD). This is accomplished by exposing the substrate to a mixture of gas precursor materials, such that these gases react and the resulting product crystallizes on top of the substrate.

[0206] During such CVD processes, conditions must be carefully controlled to ensure uniform deposition of material free of defects that could degrade the operation of the electrical device. One possible source of nonuniformity is variation in the flow rate of reactant gases to the region over the substrate. Poor control of the gas flow rate can also lead to variations in the layer thicknesses from run to run, which is another source of error. Unfortunately, there has been a significant problem in controlling the amount of gas flowed into the processing

chamber, and maintaining stable flow rates in conventional gas delivery systems.

[0207] Accordingly, FIG. 37A shows one embodiment of the present invention adapted to convey, at precisely-controllable flow rates, processing gas over the surface of a semiconductor wafer during a CVD process. Specifically, semiconductor wafer 3700 is positioned upon wafer support 3702 located within a CVD chamber. Elastomeric structure 3704 containing a large number of evenly distributed orifices 3706 is positioned just above the surface of wafer 3700.

[0208] A variety of process gases are flowed at carefully controlled rates from reservoirs 3708a and 3708b, through flow channels in elastomeric block 3704, and out of orifices 3706. As a result of the precisely controlled flow of process gases above wafer 3700, solid material 3710 having an extremely uniform structure is deposited.

[0209] Precise metering of reactant gas flow rates utilizing valve and/or pump structures of the present invention is possible for several reasons. First, gases can be flowed through valves that respond in a linear fashion to an applied actuation pressure, as is discussed above in connection with Figs. 21A and 21B. Alternatively or in addition to metering of gas flow using valves, the predictable behavior of pump structures in accordance with the present invention can be used to precisely meter process gas flow.

[0210] In addition to the chemical vapor deposition processes described above, the present technique is also useful to control gas flow in techniques such as molecular beam epitaxy and reactive ion etching.

3. Micro Mirror Arrays

[0211] While the embodiments of the present invention described thus far relate to operation of a structure composed entirely of elastomeric material, the present invention is not limited to this type of structure. Specifically, it is within the scope of the present invention to combine an elastomeric structure with a conventional, silicon-based semiconductor structure.

[0212] For example, further contemplated uses of the present microfabricated pumps and valves are in optical displays in which the membrane in an elastomeric structure reflects light either as a flat planar or as a curved surface depending upon whether the membrane is activated. As such, the membrane acts as a switchable pixel. An array of such switchable pixels, with appropriate control circuitry, could be employed as a digital or analog micro mirror array.

[0213] Accordingly, FIG. 38 shows an exploded view of a portion of one embodiment of a micro mirror array in accordance with the present invention.

[0214] Micro mirror array 3800 includes first elastomer layer 3802 overlying and separated from and underlying semiconductor structure 3804 by second elastomer layer 3806. Surface 3804a of semiconductor

structure 3804 bears a plurality of electrodes 3810. Electrodes 3810 are individually addressable through conducting row and column lines, as would be known to one of ordinary skill in the art.

[0215] First elastomeric layer 3802 includes a plurality of intersecting channels 3822 underlying an electrically conducting, reflecting elastomeric membrane portion 3802a. First elastomeric layer 3802 is aligned over second elastomeric layer 3806 and underlying semiconductor device 3804 such that points of intersection of channels 3822 overlie electrodes 3810.

[0216] In one method of fabrication first elastomeric layer 3822 may be formed by spincoating elastomeric material onto a mold featuring intersecting channels, curing the elastomer, removing the shaped elastomer from the mold, and introducing electrically conducting dopant into surface region of the shaped elastomer. Alternatively as described in connection with Figs. 7C-7G above, first elastomeric layer 3822 may be formed from two layers of elastomer by inserting elastomeric material into a mold containing intersecting channels such that the elastomeric material is flush with the height of the channel walls, and then bonding a separate doped elastomer layer to the existing elastomeric material to form a membrane on the top surface.

[0217] Alternatively, the first elastomeric layer 3802 may be produced from electrically conductive elastomer, where the electrical conductivity is due either to doping or to the intrinsic properties of the elastomer material.

[0218] During operation of reflecting structure 3800, electrical signals are communicated along a selected row line and column line to electrode 3810a. Application of voltage to electrode 3810a generates an attractive force between electrode 3810a and overlying membrane 3802a. This attractive force actuates a portion of membrane 3802a, causing this membrane portion to flex downward into the cavity resulting from intersection of the channels 3822. As a result of distortion of membrane 3802a from planar to concave, light is reflected differently at this point in the surface of elastomer structure 3802 than from the surrounding planar membrane surface. A pixel image is thereby created.

[0219] The appearance of this pixel image is variable, and may be controlled by altering the magnitude of voltage applied to the electrode. A higher voltage applied to the electrode will increase the attractive force on the membrane portion, causing further distortion in its shape. A lower voltage applied to the electrode will decrease the attractive force on the membrane, reducing distortion in its shape from the planar. Either of these changes will affect the appearance of the resulting pixel image.

[0220] A variable micro mirror array structure as described could be used in a variety of applications, including the display of images. Another application for a variable micro mirror array structure in accordance with an embodiment of the present invention would be as a high

capacity switch for a fiber optics communications system, with each pixel capable of affecting the reflection and transfer of a component of an incident light signal.

5. Refracting Structures

[0221] The micro-mirror array structure just described controls reflection of incident light. However, the present invention is not limited to controlling reflection. Yet another embodiment of the present invention enables the exercise of precise control over refraction of incident light in order to create lens and filter structures.

[0222] FIG. 39 shows one embodiment of a refractive structure in accordance with the present invention. Refractive structure 3900 includes first elastomeric layer 3902 and second elastomeric layer 3904 composed of elastomeric material capable of transmitting incident light 3906.

[0223] First elastomeric layer 3902 has convex portion 3902a which may be created by curing elastomeric material formed over a micromachined mold having a concave portion. Second elastomeric layer 3904 has a flow channel 3905 and may be created from a micromachined mold having a raised line as discussed extensively above.

[0224] First elastomer layer 3902 is bonded to second elastomer layer 3904 such that convex portion 3902a is positioned above flow channel 3905. This structure can serve a variety of purposes.

[0225] For example, light incident to elastomeric structure 3900 would be focused into the underlying flow channel, allowing the possible conduction of light through the flow channel. Alternatively, in one embodiment of an elastomeric device in accordance with the present invention, fluorescent or phosphorescent liquid could be flowed through the flow channel, with the resulting light from the fluid refracted by the curved surface to form a display.

[0226] FIG. 40 shows another embodiment of a refractive structure in accordance with the present invention. Refractive structure 4000 is a multilayer optical train based upon a Fresnel lens design. Specifically, refractive structure 4000 is composed of four successive elastomer layers 4002, 4004, 4006, and 4008, bonded together. The upper surfaces of each of first, second, and third elastomer layers 4002, 4004, and 4006 bear uniform serrations 4010 regularly spaced by a distance X that is much larger than the wavelength of the incident light. Serrations 4010 serve to focus the incident light, and may be formed through use of a micromachined mold as described extensively above. First, second, and third elastomer layers 4002, 4004, and 4006 function as Fresnel lenses as would be understood of one of ordinary skill in the art.

[0227] Fourth elastomeric layer 4008 bears uniform serrations 4012 having a much smaller size than the serrations of the overlying elastomeric layers. Serrations 4012 are also spaced apart by a much smaller distance

Y than the serrations of the overlying elastomeric layers, with Y on the order of the wavelength of incident light. such that elastomeric layer 4008 functions as a diffraction grating.

[0228] FIG. 41 illustrates an embodiment of a refractive structure in accordance with the present invention which utilizes difference in material refractive index to primarily accomplish diffraction. Refractive structure 4100 includes lower elastomeric portion 4102 covered by upper elastomeric portion 4104. Both lower elastomeric portion 4102 and upper elastomeric portion 4104 are composed of material transmitting incident light 4106. Lower elastomeric portion 4102 includes a plurality of serpentine flow channels 4108 separated by elastomeric lands 4110. Flow channels 4108 include fluid 4112 having a different refractive index than the elastomeric material making up lands 4110. Fluid 4112 is pumped through serpentine flow channels 4108 by the operation of pump structure 4114 made up of parallel control channels 4116a and 4116b overlying and separated from inlet portion 4108a of flow channel 4108 by moveable membrane 4118.

[0229] Light 4106 incident to refractive structure 4100 encounters a series of uniformly-spaced fluid-filled flow channels 4108 separated by elastomeric lands 4110. As a result of the differing optical properties of material present in these respective fluid/elastomer regions, portions of the incident light are not uniformly refracted and interact to form an interference pattern. A stack of refractive structures of the manner just described can accomplish even more complex and specialized refraction of incident light.

[0230] The refractive elastomeric structures just described can fulfill a variety of purposes. For example, the elastomeric structure could act as a filter or optical switch to block selected wavelengths of incident light. Moreover, the refractive properties of the structure could be readily adjusted depending upon the needs of a particular application.

[0231] For example, the composition (and hence refractive index) of fluid flowed through the flow channels could be changed to affect diffraction. Alternatively, or in conjunction with changing the identity of the fluid flowed, the distance separating adjacent flow channels can be precisely controlled during fabrication of the structure in order to generate an optical interference pattern having the desired characteristics.

6. Normally-Closed Valve Structure

[0232] FIGS. 7B and 7H above depict a valve structure in which the elastomeric membrane is moveable from a first relaxed position to a second actuated position in which the flow channel is blocked. However, the present invention is not limited to this particular valve configuration.

[0233] FIGS. 42A-42J show a variety of views of a normally-closed valve structure in which the elastomeric

membrane is moveable from a first relaxed position blocking a flow channel, to a second actuated position in which the flow channel is open, utilizing a negative control pressure.

[0234] FIG. 42A shows a plan view, and FIG. 42B shows a cross sectional view along line 42B-42B', of normally-closed valve 4200 in an unactuated state. Flow channel 4202 and control channel 4204 are formed in elastomeric block 4206 overlying substrate 4205. Flow channel 4202 includes a first portion 4202a and a second portion 4202b separated by separating portion 4208. Control channel 4204 overlies separating portion 4208. As shown in FIG. 42B, in its relaxed, unactuated position, separating portion 4008 remains positioned between flow channel portions 4202a and 4202b, interrupting flow channel 4202.

[0235] FIG. 42C shows a cross-sectional view of valve 4200 wherein separating portion 4208 is in an actuated position. When the pressure within control channel 4204 is reduced to below the pressure in the flow channel (for example by vacuum pump), separating portion 4208 experiences an actuating force drawing it into control channel 4204. As a result of this actuation force membrane 4208 projects into control channel 4204, thereby removing the obstacle to a flow of material through flow channel 4202 and creating a passageway 4203. Upon elevation of pressure within control channel 4204, separating portion 4208 will assume its natural position, relaxing back into and obstructing flow channel 4202.

[0236] The behavior of the membrane in response to an actuation force may be changed by varying the width of the overlying control channel. Accordingly, FIGS. 42D-42H show plan and cross-sectional views of an alternative embodiment of a normally-closed valve 4201 in which control channel 4207 is substantially wider than separating portion 4208. As shown in cross-sectional views Fig. 42E-F along line 42E-42E' of Fig. 42D, because a larger area of elastomeric material is required to be moved during actuation, the actuation force necessary to be applied is reduced.

[0237] FIGS. 42G and H show a cross-sectional views along line 40G-40G' of Fig. 40D. In comparison with the unactuated valve configuration shown in FIG. 42G, FIG. 42H shows that reduced pressure within wider control channel 4207 may under certain circumstances have the unwanted effect of pulling underlying elastomer 4206 away from substrate 4205, thereby creating undesirable void 4212.

[0238] Accordingly, Fig. 42I shows a plan view, and 42J a cross-sectional view along line 42J-42J' of Fig. 42I, of valve structure 4220 which avoids this problem by featuring control line 4204 with a minimum width except in segment 4204a overlapping separating portion 4208. As shown in Fig. 42J, even under actuated conditions the narrower cross-section of control channel 4204 reduces the attractive force on the underlying elastomer material 4206, thereby preventing this elastomer

material from being drawn away from substrate 4205 and creating an undesirable void.

[0239] While a normally-closed valve structure actuated in response to pressure is shown in Figs. 42A-42J, a normally-closed valve in accordance with the present invention is not limited to this configuration. For example, the separating portion obstructing the flow channel could alternatively be manipulated by electric or magnetic fields, as described extensively above.

7. Separation of Materials

[0240] In a further application of the present invention, an elastomeric structure can be utilized to perform separation of materials. Fig. 43 shows one embodiment of such a device.

[0241] Separation device 4300 features an elastomeric block 4301 including fluid reservoir 4302 in communication with flow channel 4304. Fluid is pumped from fluid reservoir 4306 through flow channel 4308 by peristaltic pump structure 4310 formed by control channels 4312 overlying flow channel 4304, as has been previously described at length. Alternatively, where a peristaltic pump structure in accordance with the present invention is unable to provide sufficient back pressure, fluid from a reservoir positioned outside the elastomeric structure may be pumped into the elastomeric device utilizing an external pump.

[0242] Flow channel 4304 leads to separation column 4314 in the form of a channel packed with separation matrix 4316 behind porous frit 4318. As is well known in the art of chromatography, the composition of the separation matrix 4316 depends upon the nature of the materials to be separated and the particular chromatography technique employed. The elastomeric separation structure is suitable for use with a variety of chromatographic techniques, including but not limited to gel exclusion, gel permeation, ion exchange, reverse phase, hydrophobic interaction, affinity chromatography, fast protein liquid chromatography (FPLC) and all formats of high pressure liquid chromatography (HPLC). The high pressures utilized for HPLC may require the use of urethane, dicyclopentadiene or other elastomer combinations.

[0243] Samples are introduced into the flow of fluid into separation column 4314 utilizing load channel 4319. Load channel 4319 receives fluid pumped from sample reservoir 4320 through pump 4321. Upon opening of valve 4322 and operation of pump 4321, sample is flowed from load channel 4319 into flow channel 4304. The sample is then flowed through separation column 4314 by the action of pump structure 4312. As a result of differential mobility of the various sample components in separation matrix 4316, these sample components become separated and are eluted from column 4314 at different times.

[0244] Upon elution from separation column 4314, the various sample components pass into detection region

4324. As is well known in the art of chromatography, the identity of materials eluted into detection region 4324 can be determined utilizing a variety of techniques, including but not limited to fluorescence, UV/visible/IR spectroscopy, radioactive labeling, amperometric detection, mass spectroscopy, and nuclear magnetic resonance (NMR).

[0245] A separation device in accordance with the present invention offers the advantage of extremely small size, such that only small volumes of fluid and sample are consumed during the separation. In addition, the device offers the advantage of increased sensitivity. In conventional separation devices, the size of the sample loop will prolong the injection of the sample onto the column, causing width of the eluted peaks to potentially overlap with one another. The extremely small size and capacity of the load channel in general prevents this peak diffusion behavior from becoming a problem.

[0246] The separation structure shown in Fig. 43 represents only one embodiment of such a device, and other structures are contemplated by the present invention. For example, while the separation device of Fig. 43 features a flow channel, load loop, and separation column oriented in a single plane, this is not required by the present invention. One or more of the fluid reservoir, the sample reservoir, the flow channel, the load loop, and the separation column could be oriented perpendicular to one another and/or to the plane of the elastomeric material utilizing via structures whose formation is described at length above in connection with Fig. 35A-D.

8. Cell Pen/Cell Cage/Cell Grinder

[0247] In yet a further application of the present invention, an elastomeric structure can be utilized to manipulate organisms or other biological material. Figs. 44A-44D show plan views of one embodiment of a cell pen structure in accordance with the present invention.

[0248] Cell pen array 4400 features an array of orthogonally-oriented flow channels 4402, with an enlarged "pen" structure 4404 at the intersection of alternating flow channels. Valve 4406 is positioned at the entrance and exit of each pen structure 4404. Peristaltic pump structures 4408 are positioned on each horizontal flow channel and on the vertical flow channels lacking a cell pen structure.

[0249] Cell pen array 4400 of Fig. 44A has been loaded with cells A-H that have been previously sorted, perhaps by a sorting structure as described above in conjunction with Fig. 36. Figs. 44B-44C show the accessing and removal of individually stored cell C by 1) opening valves 4406 on either side of adjacent pens 4404a and 4404b, 2) pumping horizontal flow channel 4402a to displace cells C and G, and then 3) pumping vertical flow channel 4402b to remove cell C. Fig. 44D shows that second cell G is moved back into its prior position in cell pen array 4400 by reversing the direction of liquid flow

through horizontal flow channel 4402a.

[0250] The cell pen array 4404 described above is capable of storing materials within a selected, addressable position for ready access. However, living organisms such as cells may require a continuous intake of foods and expulsion of wastes in order to remain viable. Accordingly, Figs. 45A and 45B show plan and cross-sectional views (along line 45B-45B') respectively, of one embodiment of a cell cage structure in accordance with the present invention.

[0251] Cell cage 4500 is formed as an enlarged portion 4500a of a flow channel 4501 in an elastomeric block 4503 in contact with substrate 4505. Cell cage 4500 is similar to an individual cell pen as described above in Figs. 44A-44D, except that ends 4500b and 4500c of cell cage 4500 do not completely enclose interior region 4500a. Rather, ends 4500a and 4500b of cage 4500 are formed by a plurality of retractable pillars 4502. Pillars 4502 may be part of a membrane structure of a normally-closed valve structure as described extensively above in connection with Figs. 42A-42J.

[0252] Specifically, control channel 4504 overlies pillars 4502. When the pressure in control channel 4504 is reduced, elastomeric pillars 4502 are drawn upward into control channel 4504, thereby opening end 4500b of cell cage 4500 and permitting a cell to enter. Upon elevation of pressure in control channel 4504, pillars 4502 relax downward against substrate 4505 and prevent a cell from exiting cage 4500.

[0253] Elastomeric pillars 4502 are of a sufficient size and number to prevent movement of a cell out of cage 4500, but also include gaps 4508 which allow the flow of nutrients into cage interior 4500a in order to sustain cell(s) stored therein. Pillars 4502 on opposite end 4500c are similarly configured beneath second control channel 4506 to permit opening of the cage and removal of the cell as desired.

[0254] Under certain circumstances, it may be desirable to grind/disrupt cells or other biological materials in order to access component pieces.

[0255] Accordingly, Figs. 46A and 46B show plan and cross sectional views (along line 46B-46B') respectively, of one embodiment of cell grinder structure 4600 in accordance with the present invention. Cell grinder 4600 includes a system of interdigitated posts 4602 within flow channel 4604 which close together upon actuation of integral membrane 4606 by overlying control channel 4608. By closing together, posts 4602 crush material present between them.

[0256] Posts 4602 may be spaced at intervals appropriate to disrupt entities (cells) of a given size. For disruption of cellular material, spacing of posts 4602 at an interval of about 2 μm is appropriate. In alternative embodiments of a cell grinding structure in accordance with the present invention, posts 4602 may be located entirely on the above-lying membrane, or entirely on the floor of the control channel.

9. Pressure Oscillator

[0257] In yet a further application of the present invention, an elastomeric structure can be utilized to create a pressure oscillator structure analogous to oscillator circuits frequently employed in the field of electronics. Fig. 47 shows a plan view of one embodiment of such a pressure oscillator structure.

[0258] Pressure oscillator 4700 comprises an elastomeric block 4702 featuring flow channel 4704 formed therein. Flow channel 4704 includes an initial portion 4704a proximate to pressure source 4706, and a serpentine portion 4704b distal from pressure source 4706. Initial portion 4704a is in contact with via 4708 in fluid communication with control channel 4710 formed in elastomeric block 4702 above the level of flow channel 4704. At a location more distal from pressure source 4706 than via 4708, control channel 4710 overlies and is separated from flow channel 4704 by an elastomeric membrane, thereby forming valve 4712 as previously described.

[0259] Pressure oscillator structure 4700 operates as follows. Initially, pressure source 4706 provides pressure along flow channel 4704 and control channel 4710 through via 4708. Because of the serpentine shape of flow channel 4704b, pressure is lower in region 4704b as compared with flow channel 4710. At valve 4712, the pressure difference between serpentine flow channel portion 4704b and overlying control channel 4710 eventually causes the membrane of valve 4712 to project downward into serpentine flow channel portion 4704b, closing valve 4712. Owing to the continued operation of pressure source 4706 however, pressure begins to build up in serpentine flow channel portion 4704b behind closed valve 4712. Eventually the pressure equalizes between control channel 4710 and serpentine flow channel portion 4704b, and valve 4712 opens.

[0260] Given the continuous operation of the pressure source, the above-described build up and release of pressure will continue indefinitely, resulting in a regular oscillation of pressure. Such a pressure oscillation device may perform any number of possible functions, including but not limited to timing.

9. Side-Actuated Valve

[0261] While the above description has focused upon microfabricated elastomeric valve structures in which a control channel is positioned above and separated by an intervening elastomeric membrane from an underlying flow channel, the present invention is not limited to this configuration. Figs. 48A and 48B show plan views of one embodiment of a side-actuated valve structure in accordance with one embodiment of the present invention.

[0262] Fig. 48A shows side-actuated valve structure 4800 in an unactuated position. Flow channel 4802 is formed in elastomeric layer 4804. Control channel 4806

abutting flow channel 4802 is also formed in elastomeric layer 4804. Control channel 4806 is separated from flow channel 4802 by elastomeric membrane portion 4808. A second elastomeric layer (not shown) is bonded over bottom elastomeric layer 4804 to enclose flow channel 4802 and control channel 4806.

[0263] Fig. 48B shows side-actuated valve structure 4800 in an actuated position. In response to a build up of pressure within control channel 4806, membrane 4808 deforms into flow channel 4802, blocking flow channel 4802. Upon release of pressure within control channel 4806, membrane 4808 would relax back into control channel 4806 and open flow channel 4802.

[0264] While a side-actuated valve structure actuated in response to pressure is shown in Figs. 48A and 48B, a side-actuated valve in accordance with the present invention is not limited to this configuration. For example, the elastomeric membrane portion located between the abutting flow and control channels could alternatively be manipulated by electric or magnetic fields, as described extensively above.

10. Additional Applications

[0265] The following represent further aspects of the present invention: present valves and pumps can be used for drug delivery (for example, in an implantable drug delivery device); and for sampling of biological fluids (for example, by storing samples sequentially in a column with plugs of spacer fluid therebetween, wherein the samples can be shunted into different storage reservoirs, or passed directly to appropriate sensor(s)). Such a fluid sampling device could also be implanted in the patient's body.

[0266] The present systems can also be used for devices which relieve overpressure *in vivo* using a micro-valve or pump. For example, an implantable bio-compatible micro-valve can be used to relieve overpressures in the eye which result from glaucoma. Other contemplated uses of the present switchable micro-valves include implantation in the spermatic duct or fallopian tube allowing reversible long-term or short-term birth control without the use of drugs.

[0267] Further uses of the present invention include DNA sequencing whereby the DNA to be sequenced is provided with a polymerase and a primer, and is then exposed to one type of DNA base (A, C, T, or G) at a time in order to rapidly assay for base incorporation. In such a system, the bases must be flowed into the system and excess bases washed away rapidly. Pressure driven flow, gated by elastomeric micro-valves in accordance with the present invention would be ideally suited to allow for such rapid flow and washing of reagents.

[0268] Other contemplated uses of the present micro-valve and micro-pump systems include uses with DNA chips. For example, a sample can be flowed into a looped channel and pumped around the loop with a per-

istaltic action such that the sample can make many passes over the probes of the DNA array. Such a device would give the sample that would normally be wasted sitting over the non-complimentary probes the chance to bind to a complimentary probe instead. An advantage of such a looped-flow system is that it would reduce the necessary sample volume, and thereby increase assay sensitivity.

[0269] Further applications exist in high throughput screening in which applications could benefit by the dispensing of small volumes of liquid, or by bead-based assays wherein ultrasensitive detection would substantially improve assay sensitivity.

[0270] Another contemplated application is the deposition of array of various chemicals, especially oligonucleotides, which may or may not have been chemically fabricated in a previous action of the device before deposition in a pattern or array on a substrate via contact printing through fluid channel outlets in the elastomeric device in close proximity to a desired substrate, or by a process analogous to ink-jet printing.

[0271] The present microfabricated elastomeric valves and pumps could also be used to construct systems for reagent dispensing, mixing and reaction for synthesis of oligonucleotides, peptides or other biopolymers.

[0272] Further applications for the present invention include ink jet printer heads, in which small apertures are used to generate a pressure pulse sufficient to expel a droplet. An appropriately actuated micro-valve in accordance with the present invention can create such a pressure pulse. The present micro-valves and pumps can also be used to digitally dispense ink or pigment, in amounts not necessarily as small as single droplets. The droplet would be brought into contact with the medium being printed on rather than be required to be fired through the air.

[0273] Yet other uses of the present systems are in fluidic logic circuits which offer the advantages of being useable in radiation resistant applications. A further advantage of such fluidic logic circuits is that, being non-electronic, such fluidic logic circuitry may not be probed by electro magnetic sensors, thus offering a security benefit.

[0274] Yet further uses of the present invention would take advantage of the ready removal and reattachment of the structure from an underlying substrate such as glass, utilizing a glass substrate patterned with a binding or other material. This allows separate construction of a patterned substrate and elastomer structure. For instance, a glass substrate could be patterned with a DNA microarray, and an elastomer valve and pump structure sealed over the array in a subsequent step.

11. Additional Aspects of the Invention

[0275] The following represent further uses of the present invention: the use of a deflectable membrane to

control flow of a fluid in a microfabricated channel of an elastomeric structure; the use of elastomeric layers to make a microfabricated elastomeric device containing a microfabricated movable portion; and the use of an elastomeric material to make a microfabricated valve or pump.

[0276] A microfabricated elastomeric structure in accordance with one embodiment of the present invention comprises an elastomeric block formed with microfabricated recesses therein, a portion of the elastomeric block deflectable when the portion is actuated. The recesses comprise a first microfabricated channel and a first microfabricated recess, and the portion comprises an elastomeric membrane deflectable into the first microfabricated channel when the membrane is actuated. The recesses have a width in the range of 10 μm to 200 μm and the portion has a thickness of between about 2 μm and 50 μm . The microfabricated elastomeric structure may be actuated at a speed of 100 Hz or greater and contains substantially no dead volume when the portion is actuated.

[0277] A method of actuating an elastomeric structure comprises providing an elastomeric block formed with first and second microfabricated recesses therein, the first and second microfabricated recesses separated by a membrane portion of the elastomeric block deflectable into one of the first and second recesses in response to an actuation force, and applying an actuation force to the membrane portion such that the membrane portion is deflected into one of the first and the second recesses.

[0278] A method of microfabricating an elastomeric structure in accordance with one embodiment of the present invention comprises forming a first elastomeric layer on a substrate, curing the first elastomeric layer, and patterning a first sacrificial layer over the first elastomeric layer. A second elastomeric layer is formed over the first elastomeric layer, thereby encapsulating the first patterned sacrificial layer between the first and second elastomeric layers, the second elastomeric layer is cured, and the first patterned sacrificial layer is removed selective to the first elastomeric layer and the second elastomeric layer, thereby forming at least one first recess between the first and second layers of elastomer.

[0279] An alternative method of fabricating further comprises patterning a second sacrificial layer over the substrate prior to forming the first elastomeric layer, such that the second patterned sacrificial layer is removed during removal of the first patterned sacrificial layer to form at least one recess along a bottom of the first elastomeric layer.

[0280] A microfabricated elastomeric structure in accordance with one embodiment of the present invention comprises an elastomeric block, a first channel and a second channel separated by a separating portion of the elastomeric structure, and a microfabricated recess in the elastomeric block adjacent to the separating portion such that the separating portion may be actuated to deflect into the microfabricated recess. 66. Deflection of

the separating portion opens a passageway between the first and second channels.

[0281] A method of controlling fluid or gas flow through an elastomeric structure comprises providing an elastomeric block, the elastomeric block having first, second, and third microfabricated recesses, and the elastomeric block having a first microfabricated channel passing therethrough, the first, second and third microfabricated recesses separated from the first channel by respective first, second and third membranes deflectable into the first channel, and deflecting the first, second and third membranes into the first channel in a repeating sequence to peristaltically pump a flow of fluid through the first channel.

[0282] A method of microfabricating an elastomeric structure, comprising microfabricating a first elastomeric layer, microfabricating a second elastomeric layer; positioning the second elastomeric layer on top of the first elastomeric layer; and bonding a bottom surface of the second elastomeric layer onto a top surface of the first elastomeric layer.

[0283] While the present invention has been described herein with reference to particular embodiments thereof, a latitude of modification, various changes and substitutions are intended in the foregoing disclosure, and it will be appreciated that in some instances some features of the invention will be employed without a corresponding use of other features without departing from the scope of the invention as set forth. Therefore, many modifications may be made to adapt a particular situation or material to the teachings of the invention without departing from the essential scope and spirit of the present invention. It is intended that the invention not be limited to the particular embodiment disclosed as the best mode contemplated for carrying out this invention, but that the invention will include all embodiments and equivalents falling within the scope of the claims.

Claims

1. A microfabricated elastomeric structure, comprising:

a planar substrate (14);
 a first elastomeric layer (20) having a top surface, and a bottom surface with flow recesses (21) formed therein; and
 a second elastomeric layer (22) having a bottom surface with a control recess (23) formed therein, the control recess having both a wide and a narrow flow recess portion disposed along its length;

wherein the first layer is positioned on top of the planar substrate forming first and second flow channels (30A, 30B) between the flow recesses of the first elastomeric layer and the planar substrate, and

the bottom surface of the second elastomeric layer is bonded onto the top surface of the first elastomeric layer forming a control channel (32) between the control recess of the second elastomeric layer and the top surface of the first elastomeric layer, the control channel having both a wide and a narrow control channel portion corresponding to the wide and narrow control recess portions, with the wide control channel portion being disposed over the first flow channel, and the narrow control portion being disposed over the second flow channel.

2. The elastomeric structure of claim 1, wherein when the control channel is at a pressure greater than the flow channel, a deflectable region (25) formed between the wide control channel portion and the first flow channel deflects into the first flow channel.

3. The elastomeric structure of claim 2, wherein when the deflectable region deflects into the first flow channel, fluid flow within the first flow channel is altered.

4. The elastomeric structure of claim 3, wherein when the fluid flow in the first flow channel is altered, fluid flow in the second flow channel is either not altered or altered less than the fluid flow in the first flow channel.

5. The elastomeric structure of claim 1, wherein at least either the first or second elastomeric layer is formed wholly or partly from an elastomer.

6. The elastomeric structure of claim 5, wherein the elastomer is a silicone elastomer.

7. The elastomeric structure of claim 6, wherein the silicone elastomer is polydimethylsiloxane (PDMS).

8. The elastomeric structure of claim 1, wherein the planar substrate is rigid.

9. The elastomeric structure of claim 1, wherein the planar substrate is glass.

10. The elastomeric structure of claim 1, wherein the planar substrate is plastic.

11. The elastomeric structure of claim 1, wherein the planar substrate is formed wholly or partly from an elastomer.

12. The elastomeric structure of claim 11, wherein the planar substrate is formed wholly or partly from a silicone elastomer.

13. The elastomeric structure of claim 12, wherein the silicone elastomer is polydimethylsiloxane (PDMS).

14. The elastomeric structure of claim 1, further comprising third and fourth flow recesses in the first elastomeric layer forming third and fourth flow channels (30C, 30D) with the substrate, second, third, and fourth control recesses in the second elastomeric layer forming second, third, and fourth control channels (32B, 32C, 32D) with the first elastomeric layer, each control channel having wide and narrow control channel portions, the wide control channel portions of the first control channel being located where the first control channel crosses over the first, second, and third flow channels, the wide portions of the second control channel being located where the second control channel crosses over the first, second, and fourth flow channels, the wide portions of the third control channel being located where the third control channel crosses over the first, third, and fourth flow channels, and the wide portions of the fourth control channel crosses over the second, third and fourth flow channels.

15. A method for controlling a flow of a fluid in a microfluidic structure comprising the steps of:

(i) providing the elastomeric structure, comprising:

- a planar substrate (14);
- a first elastomeric layer (20) having a top surface, and a bottom surface with first and second flow recesses (21) formed therein; and
- a second elastomeric layer (22) having a bottom surface with a control recess (23) formed therein, the control recess having both a wide and a narrow flow recess portion disposed along its length;

wherein the first layer is positioned on top of the planar substrate forming first and second flow channels (30A, 30B) between the flow recesses of the first elastomeric layer and the planar substrate, and the bottom surface of the second elastomeric layer is bonded onto the top surface of the first elastomeric layer forming a control channel (32) between the control recess of the second elastomeric layer and the top surface of the first elastomeric layer, the control channel having both a wide and a narrow control channel portion corresponding to the wide and narrow control recess portions, with the wide control channel portion being disposed over the first flow channel, and the narrow control portion being disposed over the second flow channel, and a deflectable region (25) being formed between the wide control channel portion and the first flow channel;

(ii) controlling the control channel pressure so

that it is greater than the pressure within the flow channel so that the deflectable region deflects into the first flow channel to alter the flow of the fluid within the first flow channel and the fluid flow in the second flow channel is either not altered or altered less than the fluid flow in the first flow channel.

16. Use of an elastomeric microfluidic device having a control channel (32) to selectively permit fluid flow in fluid flow channels (30A and 30B), said control channel having a first portion with a first width overlying a first of said fluid flow channels (30A) and a second portion having a second width overlying a second of said fluid flow channels (30B), wherein control of fluid flow in the fluid flow channels is separately effected by deflection, into the fluid flow channels, of separate membranes (25A and 25B) separating the control channel from each fluid flow channel, and wherein the width of the membrane separating each fluid flow channel from the control channel depends upon the width of the corresponding overlying portion of the control channel, the differing widths of the separate membranes affecting the degree of deflection into the fluid flow channels thereby providing said selective permission of fluid flow.

17. A use as claimed in claim 16, wherein the elastomeric microfluidic device comprises the features of any of claims 1 to 14.

Patentansprüche

1. In Mikrofabrikationstechnologie hergestellte elastomere Struktur, umfassend:

- ein planares Substrat (14);
- eine erste elastomere Schicht (20) mit einer Oberseite und einer Unterseite mit darin gebildeten Strömungsaussparungen (21); und
- eine zweite elastomere Schicht (22) mit einer Unterseite mit einer darin gebildeten Steuerausparung (23), wobei die Steuerausparung sowohl einen breiten als auch einen engen Strömungsaussparungsabschnitt aufweist, die deren Länge nach angeordnet sind;

worin die erste Schicht oben auf dem planaren Substrat angeordnet ist, wobei erste und zweite Strömungskanäle (30A, 30B) zwischen den Strömungsaussparungen der ersten elastomeren Schicht und dem planaren Substrat gebildet sind, und die Unterseite der zweiten elastomeren Schicht auf der Oberseite der ersten elastomeren Schicht befestigt ist, wobei ein Steuerkanal (32) zwischen der Steuerausparung der zweiten elastomeren

- Schicht und der Oberseite der ersten elastomeren Schicht gebildet ist, wobei der Steuerkanal sowohl einen breiten als auch einen engen Steuerkanalabschnitt aufweist, die den breiten und engen Steuer-
aussparungsabschnitten entsprechen, worin der
5 breite Steuerkanalabschnitt über dem ersten Strömungskanal angeordnet ist und der enge Steuerkanalabschnitt über dem zweiten Strömungskanal angeordnet ist.
2. Elastomere Struktur gemäß Anspruch 1, wobei dann, wenn der Druck im Steuerkanal größer ist als im Strömungskanal, ein auslenkbarer Bereich (25), welcher zwischen dem breiten Steuerkanalabschnitt und dem ersten Strömungskanal gebildet ist, in den ersten Strömungskanal auslenkt. 10
3. Elastomere Struktur gemäß Anspruch 2, wobei dann, wenn der auslenkbare Bereich in den ersten Strömungskanal auslenkt, die Fluidströmung innerhalb des ersten Strömungskanals verändert wird. 15
4. Elastomere Struktur gemäß Anspruch 3, wobei dann, wenn die Fluidströmung in dem ersten Strömungskanal verändert wird, die Fluidströmung in dem zweiten Strömungskanal entweder nicht verändert wird oder weniger verändert wird als die Fluidströmung in dem ersten Strömungskanal. 20
5. Elastomere Struktur gemäß Anspruch 1, worin wenigstens entweder die erste oder die zweite elastomere Schicht vollständig oder teilweise aus einem Elastomer gebildet ist. 25
6. Elastomere Struktur gemäß Anspruch 5, worin es sich bei dem Elastomer um ein Silikon-Elastomer handelt. 30
7. Elastomere Struktur gemäß Anspruch 6, worin es sich bei dem Silikon-Elastomer um Polydimethylsiloxan (PDMS) handelt. 35
8. Elastomere Struktur gemäß Anspruch 1, worin das planare Substrat steif ist. 40
9. Elastomere Struktur gemäß Anspruch 1, worin es sich bei dem planaren Substrat um Glas handelt. 45
10. Elastomere Struktur gemäß Anspruch 1, worin es sich bei dem planaren Substrat um Kunststoff handelt. 50
11. Elastomere Struktur gemäß Anspruch 1, worin das planare Substrat vollständig oder teilweise aus einem Elastomer gebildet ist. 55
12. Elastomere Struktur gemäß Anspruch 11, worin das planare Substrat vollständig oder teilweise aus einem Silikon-Elastomer gebildet ist.
13. Elastomere Struktur gemäß Anspruch 12, worin es sich bei dem Silikon-Elastomer um Polydimethylsiloxan (PDMS) handelt.
14. Elastomere Struktur gemäß Anspruch 1, zusätzlich umfassend dritte und vierte Strömungsaussparungen in der ersten elastomeren Schicht, die dritte und vierte Strömungskanäle (30C, 30D) mit dem Substrat bilden, zweite, dritte und vierte Steuer-
aussparungen in der zweiten elastomeren Schicht, die zweite, dritte und vierte Steuerkanäle (328, 32C, 32D) mit der ersten elastomeren Schicht bilden, wobei jeder Steuerkanal breite und enge Steuerkanalabschnitte des ersten Steuerkanals dort angeordnet sind, wo der erste Steuerkanal über die ersten, zweiten und dritten Strömungskanäle kreuzt, wobei die breiten Abschnitte des zweiten Steuerkanals dort angeordnet sind, wo der zweite Steuerkanal über die ersten, zweiten und vierten Strömungskanäle kreuzt, wobei die breiten Abschnitte des dritten Steuerkanals dort angeordnet sind, wo der dritte Steuerkanal über die ersten, dritten und vierten Steuerkanäle kreuzt und wobei die breiten Abschnitte des vierten Steuerkanals über die zweiten, dritten und vierten Steuerkanäle kreuzen.
15. Verfahren zum Steuern einer Strömung eines Fluids in einer Mikrofluid-Struktur umfassend die Schritte von:
- (i) Bereitstellen der elastomeren Struktur, umfassend:
- ein planares Substrat (14);
eine erste elastomere Schicht (20) mit einer Oberseite und einer Unterseite mit darin gebildeten Strömungsaussparungen (21); und
eine zweite elastomere Schicht (22) mit einer Unterseite mit einer darin gebildeten Steuer-
aussparung (23), wobei die Steuer-
aussparung sowohl einen breiten als auch einen engen Strömungsaussparungsabschnitt aufweist, die deren Länge nach angeordnet sind;
- worin die erste Schicht oben auf dem planaren Substrat angeordnet ist, wobei erste und zweite Strömungskanäle (30A, 30B) zwischen den Strömungsaussparungen der ersten elastomeren Schicht und dem planaren Substrat gebildet sind, und die Unterseite der zweiten elastomeren Schicht auf der Oberseite der ersten elastomeren Schicht befestigt ist, wobei ein Steuerkanal (32) zwischen der Steuer-

sparung der zweiten elastomeren Schicht und der Oberseite der ersten elastomeren Schicht gebildet ist, wobei der Steuerkanal sowohl einen breiten als auch einen engen Steuerkanalabschnitt aufweist, die den breiten und engen 5 Steueraussparungsabschnitten entsprechen, worin der breite Steuerkanalabschnitt über dem ersten Strömungskanal angeordnet ist und der enge Steuerkanalabschnitt über dem 10 zweiten Strömungskanal angeordnet ist, und worin ein auslenkbarer Bereich (25) zwischen dem breiten Steuerkanalabschnitt und dem ersten Strömungskanal gebildet ist;

(ii) Steuern des Steuerkanaldrucks derart, dass er größer ist als der Druck innerhalb des Strömungskanals, so dass der auslenkbare Bereich in den ersten Strömungskanal auslenkt, um die Strömung des Fluids innerhalb des ersten Strömungskanals zu verändern und die Fluidströmung in dem zweiten Strömungskanal 20 wird entweder nicht verändert oder weniger verändert als die Fluidströmung in dem ersten Strömungskanal.

16. Verwendung einer elastomeren Mikrofluid-Vorrichtung mit einem Steuerkanal (32), um selektiv Fluidströmung in Fluidströmungskanälen (30A und 30B) zu ermöglichen, wobei der Steuerkanal einen ersten Abschnitt mit einer ersten Breite aufweist, welcher einen ersten dieser Fluidströmungskanäle (30A) überdeckt, und einen zweiten Abschnitt mit einer zweiten Breite aufweist, welcher einen zweiten dieser Fluidströmungskanäle (30B) überdeckt, worin die Steuerung der Fluidströmung in den Fluidströmungskanälen getrennt durch Auslenkung vorgenommen wird, in die Fluidströmungskanäle, von separaten Membranen (25A und 25B), die den Steuerkanal von jedem Fluidströmungskanal abtrennen, und worin die Breite der Membran, die jeden Fluidströmungskanal von dem Steuerkanal abtrennt, von der Breite des entsprechenden überdeckenden Abschnitts des Steuerkanals abhängt, wobei die unterschiedlichen Breiten der separaten Membranen das Ausmaß der Auslenkung in die Fluidströmungskanäle beeinflusst, wodurch die selektive Zulassung von Fluidströmung bereitgestellt wird.

17. Verwendung gemäß Anspruch 16, worin die elastomere Mikrofluid-Vorrichtung die Merkmale von einem der Ansprüche 1 bis 14 umfasst.

Revendications

1. Structure élastomère micro fabriquée, comprenant :

un substrat plan (14) ;
une première couche élastomère (20) ayant une surface supérieure, et une surface inférieure avec des évidements (21) d'écoulement formés dans celle-ci ; et
une seconde couche élastomère (22) ayant une surface inférieure avec un évidement (23) de régulation formé dans celle-ci, l'évidement de régulation ayant à la fois une portion d'évidement d'écoulement large et une portion d'évidement d'écoulement étroite disposées sur toute sa longueur ;

dans laquelle la première couche est positionnée sur le dessus du substrat plan pour former des premier et deuxième canaux d'écoulement (30A, 30B) entre les évidements d'écoulement de la première couche élastomère et le substrat plan, et la surface inférieure de la seconde couche élastomère est collée sur la surface supérieure de la première couche élastomère pour former un canal de régulation (32) entre l'évidement de régulation de la seconde couche élastomère et la surface supérieure de la première couche élastomère, le canal de régulation ayant à la fois une portion de canal de régulation large et une portion de canal de régulation étroite qui correspondent aux portions d'évidement de régulation large et étroite, la portion de canal de régulation large étant disposée au-dessus du premier canal d'écoulement, et la portion de régulation étroite étant disposée au-dessus le deuxième canal d'écoulement.

2. Structure élastomère selon la revendication 1, dans laquelle lorsque le canal de régulation est à une pression plus élevée que le canal d'écoulement, une région de déflexion (25) formée entre la portion de canal de régulation large et le premier canal d'écoulement fléchit à l'intérieur du premier canal d'écoulement.

3. Structure élastomère selon la revendication 2, dans laquelle lorsque la région de déflexion fléchit à l'intérieur du premier canal d'écoulement, l'écoulement de fluide à l'intérieur du premier canal d'écoulement est altéré.

4. Structure élastomère selon la revendication 3, dans laquelle lorsque l'écoulement de fluide à l'intérieur du premier canal d'écoulement est altéré, l'écoulement de fluide à l'intérieur du deuxième canal d'écoulement, soit n'est pas altéré, soit est moins altéré que l'écoulement de fluide à l'intérieur du premier canal d'écoulement.

5. Structure élastomère selon la revendication 1, dans laquelle au moins soit la première couche élastomère, soit la seconde couche d'élastomère est réa-

- lisée en tout ou en partie à partir d'un élastomère.
6. Structure élastomère selon la revendication 5, dans laquelle l'élastomère est un élastomère silicone. 5
7. Structure élastomère selon la revendication 6, dans laquelle l'élastomère silicone est du polydiméthylsiloxane (PDMS). 5
8. Structure élastomère selon la revendication 1, dans laquelle le substrat plan est rigide. 10
9. Structure élastomère selon la revendication 1, dans laquelle le substrat plan est du verre. 15
10. Structure élastomère selon la revendication 1, dans laquelle le substrat plan est du plastique. 15
11. Structure élastomère selon la revendication 1, dans laquelle le substrat plan est réalisé en tout ou en partie à partir d'un élastomère. 20
12. Structure élastomère selon la revendication 11, dans laquelle le substrat plan est réalisé en tout ou en partie à partir d'un élastomère silicone. 25
13. Structure élastomère selon la revendication 12, dans laquelle l'élastomère silicone est du polydiméthylsiloxane (PDMS). 30
14. Structure élastomère selon la revendication 1, comprenant en outre des troisième et quatrième évidements d'écoulement dans la première couche élastomère pour former des troisième et quatrième canaux d'écoulement (30C, 30D) avec le substrat ; les deuxième, troisième et quatrième évidements de régulation dans la seconde couche élastomère formant des deuxième, troisième et quatrième canaux de régulation (32B, 32C, 32D) avec la première couche élastomère ; chaque canal de régulation ayant des portions de canal de régulation larges et des portions de canal de régulation étroites, les portions de canal de régulation larges du premier canal de régulation étant positionnées à l'endroit où le premier canal de régulation passe par-dessus les premier, deuxième et troisième canaux d'écoulement, les portions larges du deuxième canal de régulation étant positionnées à l'endroit où le deuxième canal de régulation passe au-dessus des premier, deuxième et quatrième canaux d'écoulement, les portions larges du troisième canal de régulation étant positionnées à l'endroit où le troisième canal de régulation passe au-dessus des premier, troisième et quatrième canaux d'écoulement, et les portions larges du quatrième canal de régulation passent au-dessus des deuxième, troisième et quatrième canaux d'écoulement. 35
40
45
50
55
15. Procédé pour réguler un écoulement d'un fluide dans une structure micro fluidique, le procédé comprenant les étapes consistant à :
- (i) fournir la structure élastomère, comprenant :
- un substrat plan (14) ;
une première couche élastomère (20) ayant une surface supérieure, et une surface inférieure avec des premier et deuxième évidements d'écoulement (21) formés dans celle-ci ; et
une seconde couche élastomère (22) ayant une surface inférieure avec un évidement de régulation (23) formé dans celle-ci, l'évidement de régulation ayant à la fois une portion d'évidement d'écoulement large et une portion d'évidement d'écoulement étroite disposées sur toute sa longueur ;
- dans laquelle la première couche est positionnée au-dessus du substrat plan pour former des premier et deuxième canaux d'écoulement (30A, 30B) entre les évidements d'écoulement de la première couche élastomère et le substrat plan, et la surface inférieure de la seconde couche élastomère est collée sur la surface supérieure de la première couche élastomère pour former un canal de régulation (32) entre l'évidement de régulation de la seconde couche élastomère et la surface supérieure de la première couche élastomère, le canal de régulation ayant à la fois une portion de régulation large et une portion de régulation étroite qui correspondent aux portions d'évidement de régulation large et étroite, la portion de canal de régulation large étant disposée au-dessus du premier canal d'écoulement, et la portion de canal de régulation étroite étant disposée au-dessus du deuxième canal d'écoulement, et une région de déflexion (25) étant formée entre la portion de canal de régulation large et le premier canal d'écoulement ;
- (ii) réguler la pression du canal de régulation de manière à ce qu'elle soit plus élevée que la pression à l'intérieur du canal d'écoulement de telle sorte que la région de déflexion fléchisse à l'intérieur du premier canal d'écoulement afin d'altérer l'écoulement du fluide à l'intérieur du premier canal d'écoulement et que l'écoulement de fluide dans le deuxième canal d'écoulement, soit ne soit pas altéré, ou qu'il soit moins altéré que l'écoulement de fluide à l'intérieur du premier canal d'écoulement.
16. Utilisation d'un dispositif micro-fluidique élastomère ayant un canal de régulation (32) pour permettre de

façon sélective un écoulement de fluide dans des canaux d'écoulement de fluide (30A et 30B), ledit canal de régulation ayant une première portion avec une première largeur qui recouvre un premier desdits canaux d'écoulement de fluide (30A) et une seconde portion ayant une seconde largeur qui recouvre une seconde portion desdits canaux d'écoulement de fluide (30B), dans laquelle la régulation de l'écoulement de fluide à l'intérieur des canaux d'écoulement de fluide est effectuée séparément par la déflexion, à l'intérieur des canaux d'écoulement de fluide, de membranes séparées (25A et 25B) séparant le canal de régulation par rapport à chaque canal écoulement de fluide, et dans laquelle la largeur de la membrane séparant chaque canal d'écoulement de fluide par rapport au canal de régulation dépend de la largeur de la portion de recouvrement correspondante du canal de régulation, les largeurs différentes des membranes séparées affectant le degré de déflexion à l'intérieur des canaux d'écoulement de fluide pour fournir de ce fait ladite permission sélective d'écoulement de fluide.

17. Utilisation selon la revendication 16, dans laquelle le dispositif micro-fluidique élastomère comprend les caractéristiques selon l'une quelconque des revendications 1 à 14.

30

35

40

45

50

55

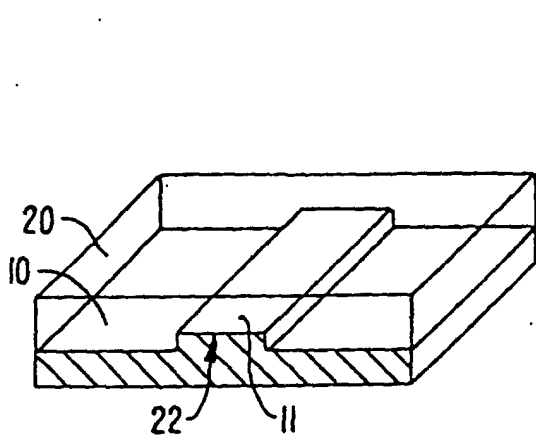

FIG. 1.

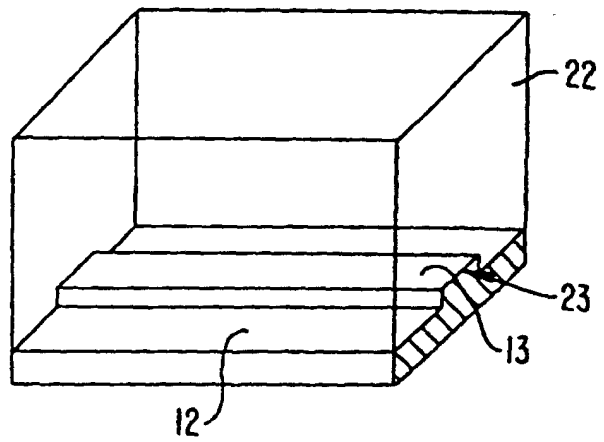

FIG. 2.

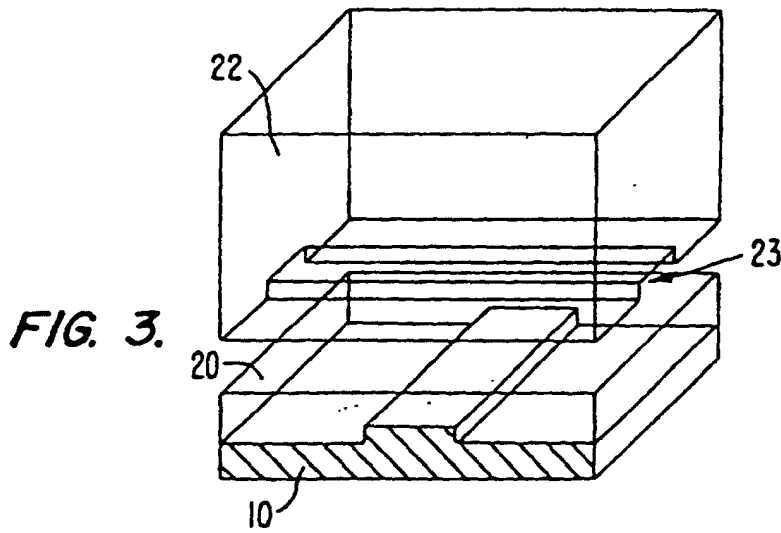

FIG. 3.

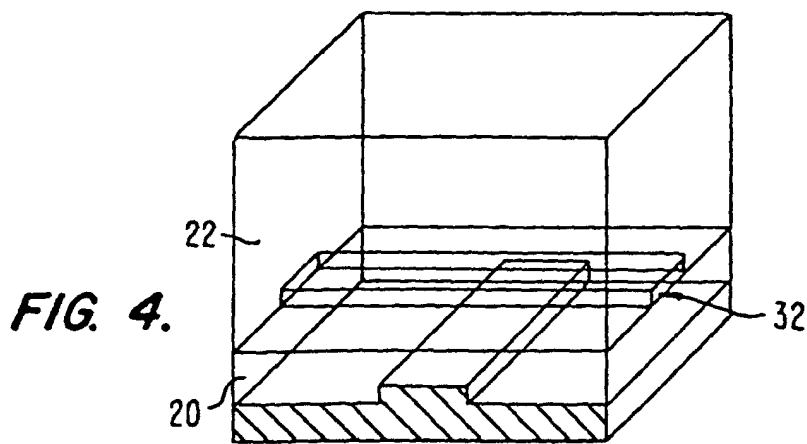

FIG. 4.

FIG. 5.

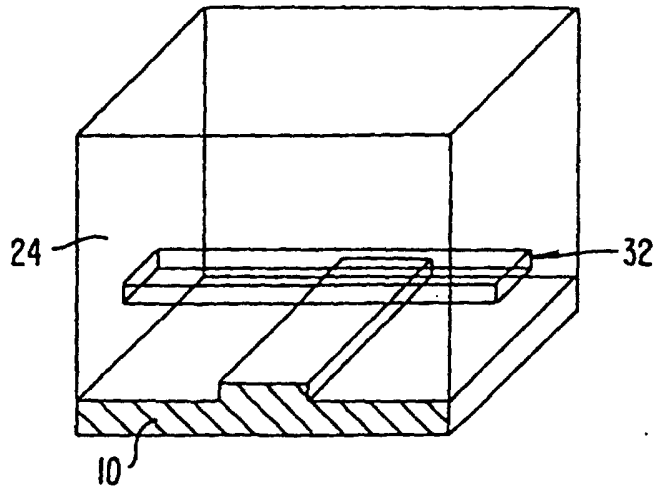

FIG. 6.

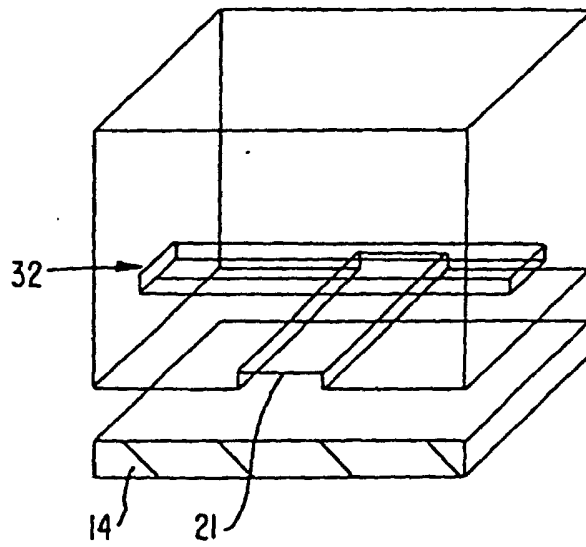
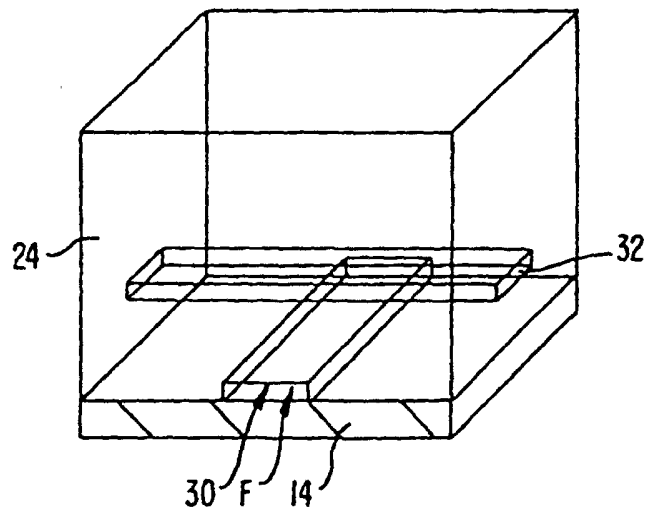

FIG. 7A.



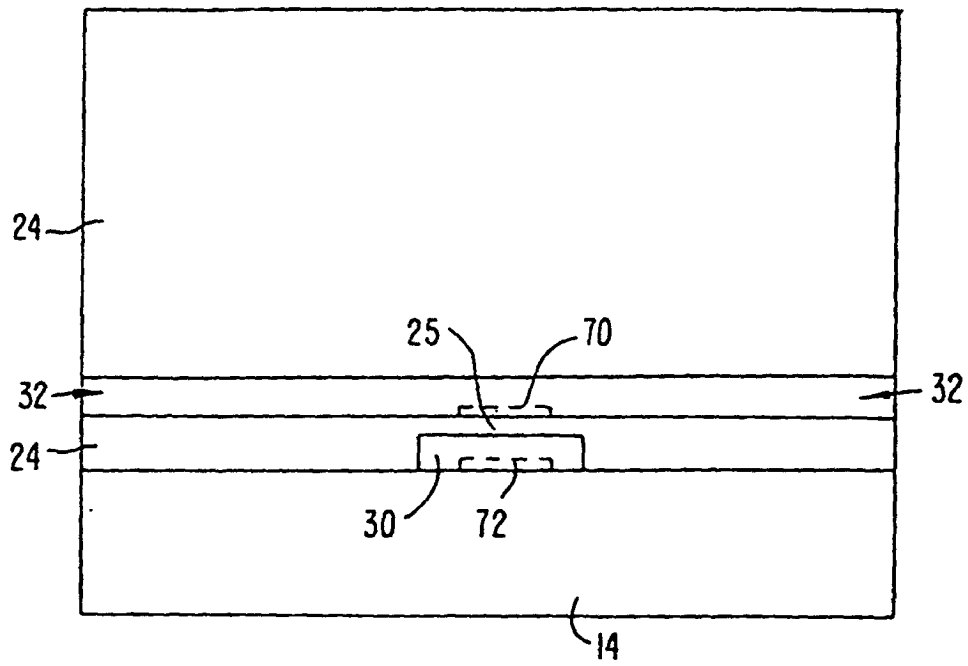

FIG. 7B.

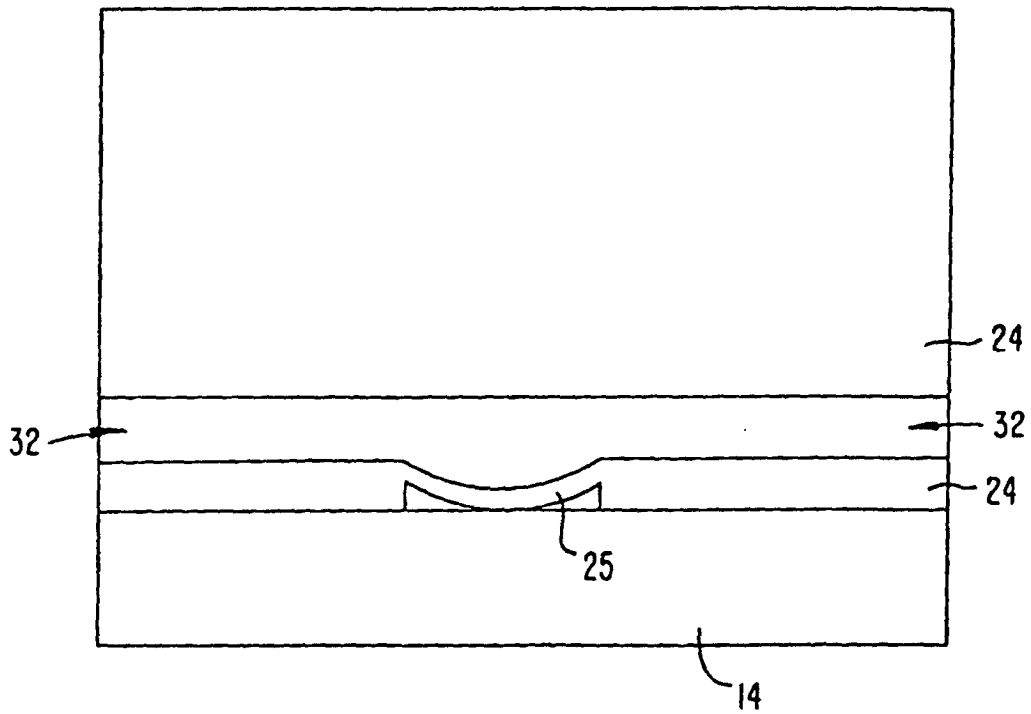

FIG. 7H.

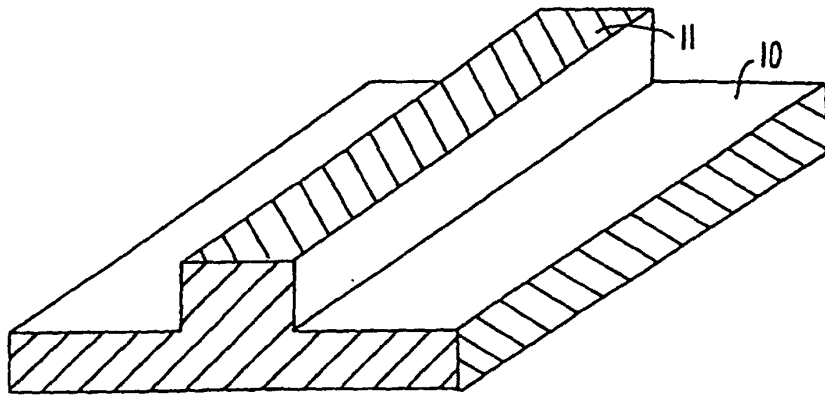

FIG. 7C.

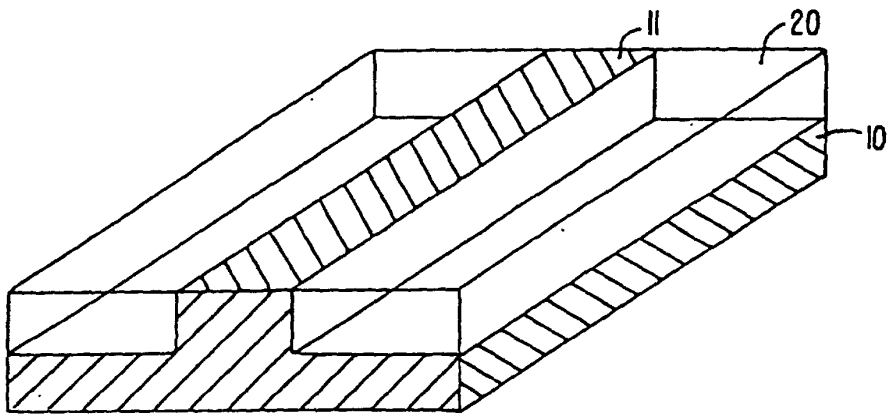

FIG. 7D.

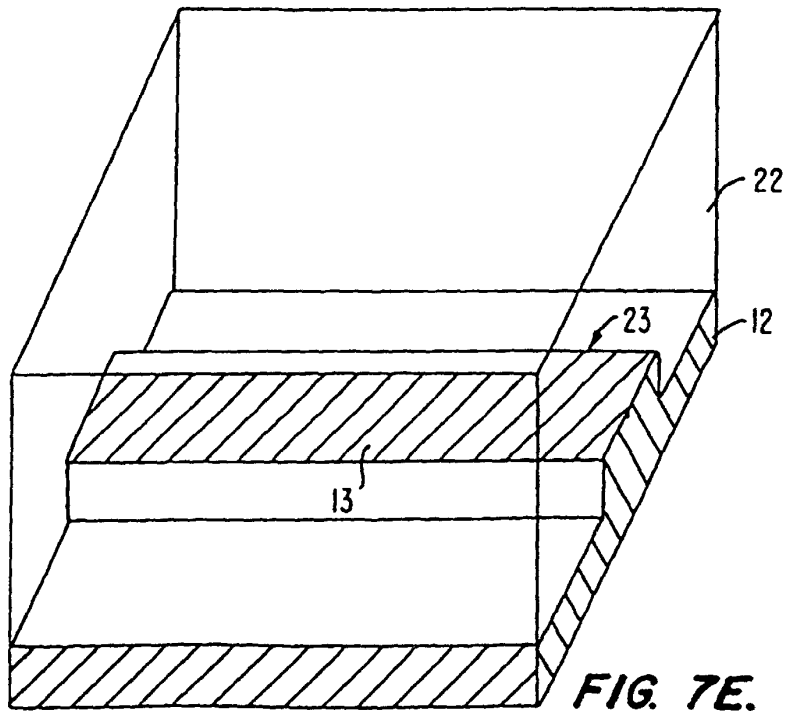

FIG. 7E.

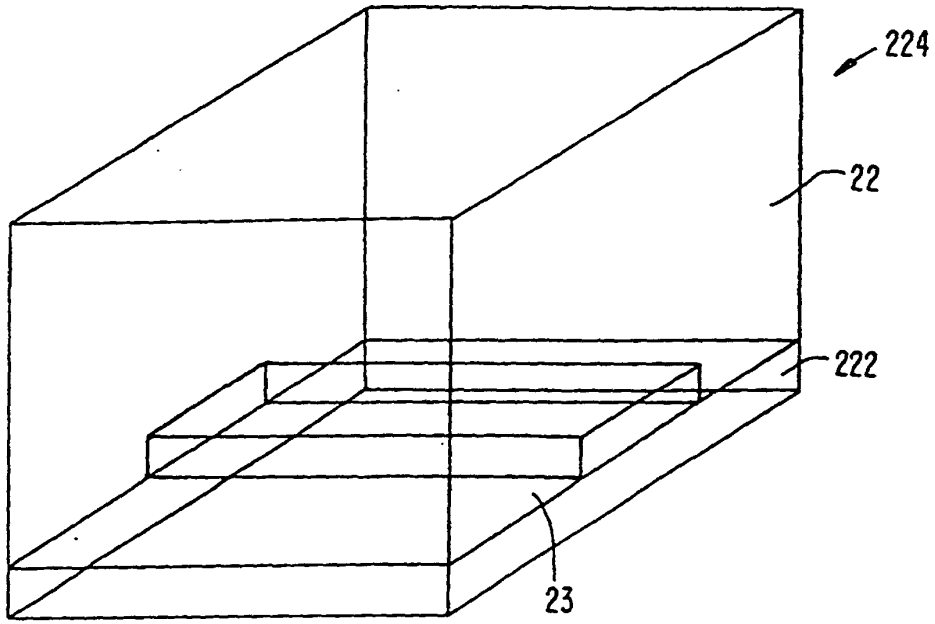

FIG. 7F.

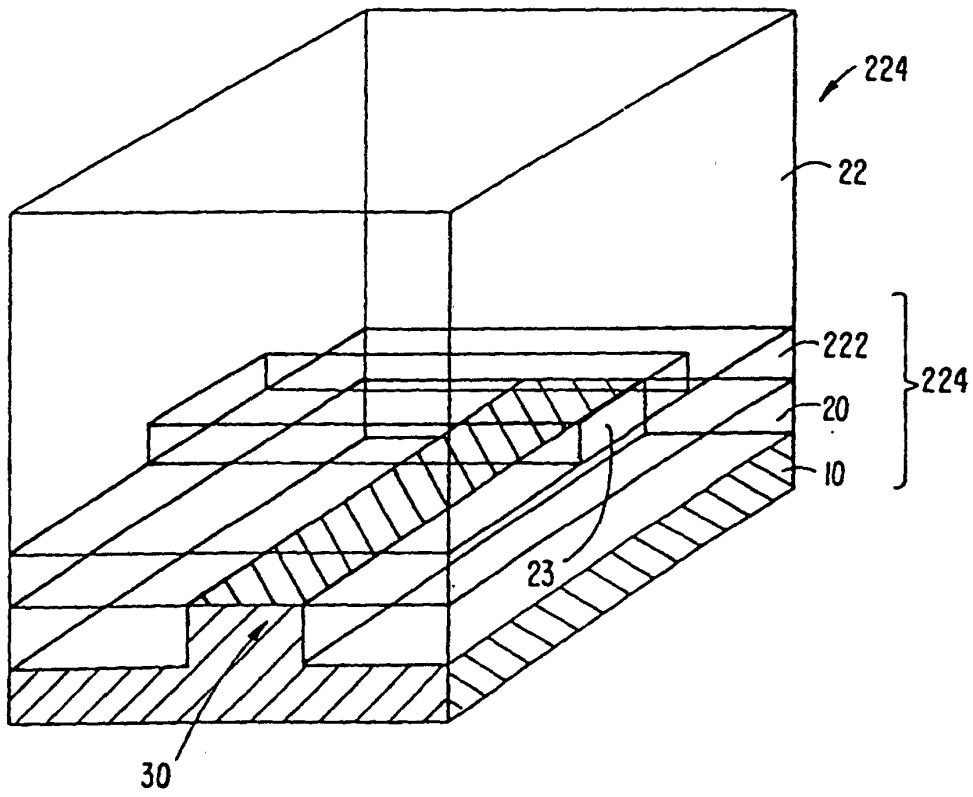

FIG. 7G.

FIG. 8.

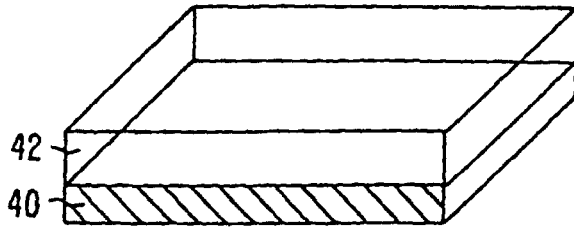

FIG. 9.

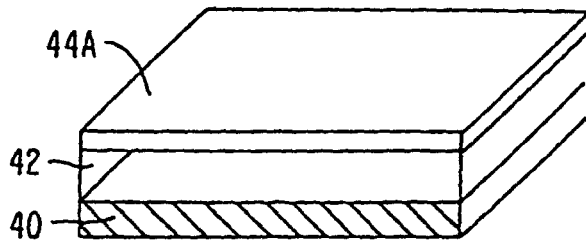

FIG. 10.

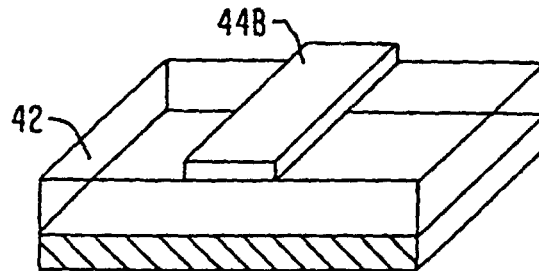

FIG. 11.

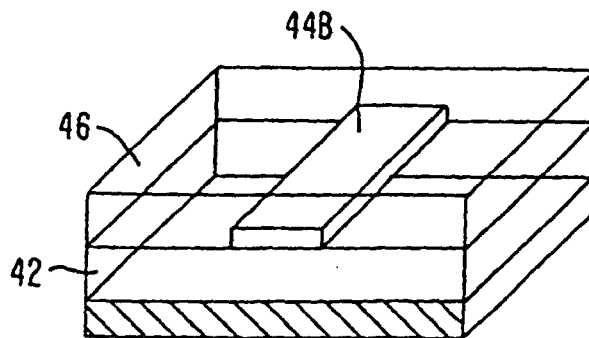

FIG. 12.

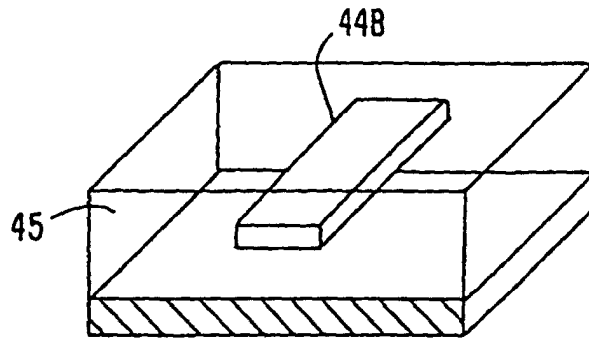

FIG. 13.

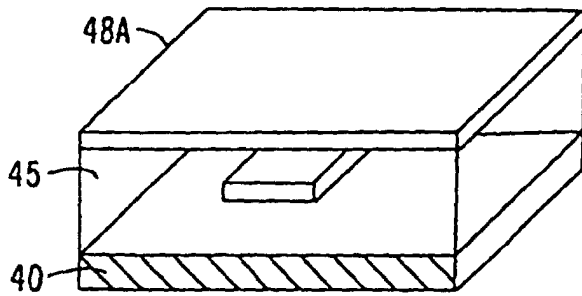

FIG. 14.

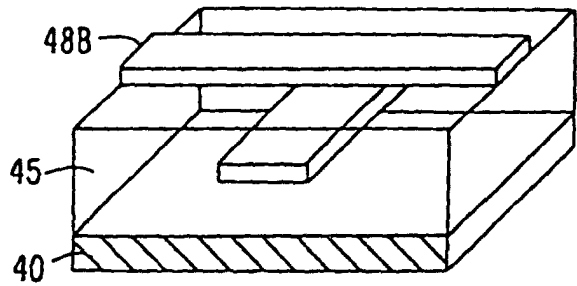
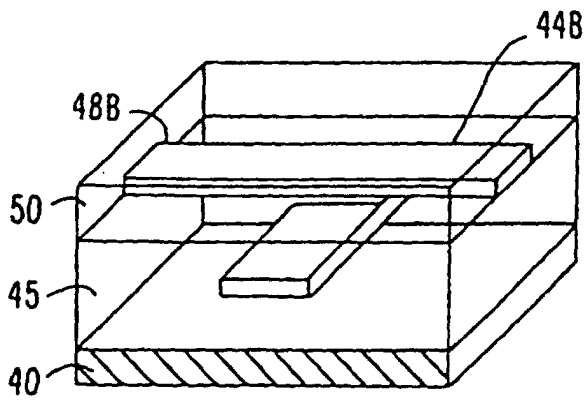
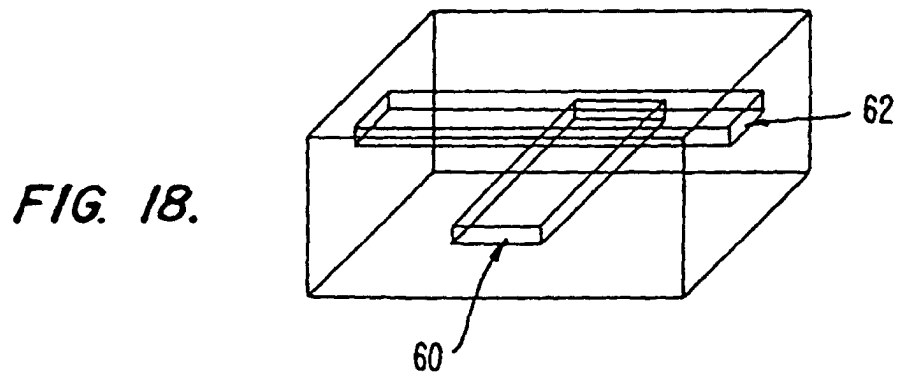
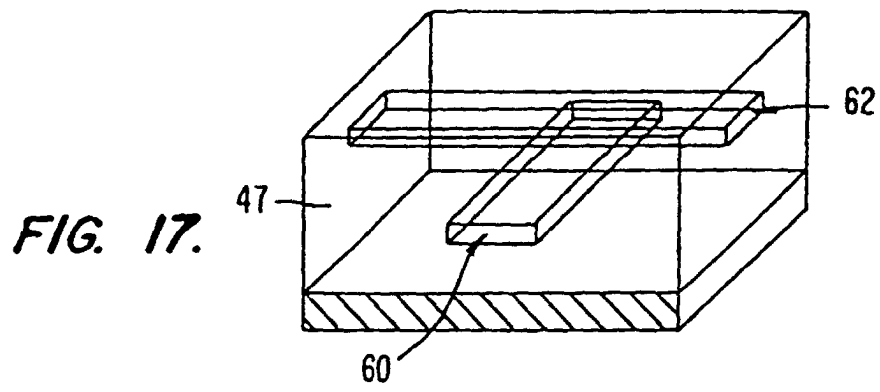
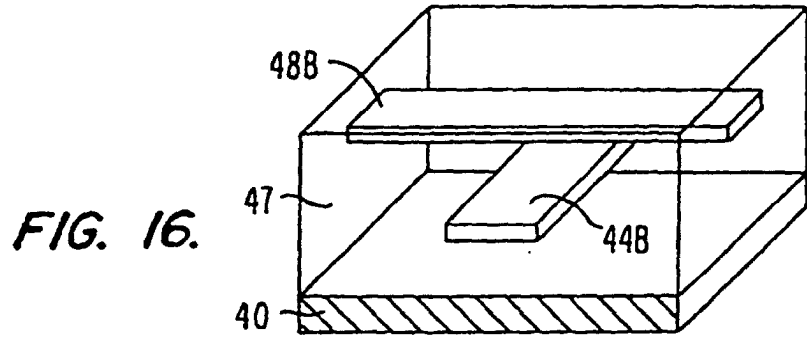

FIG. 15.





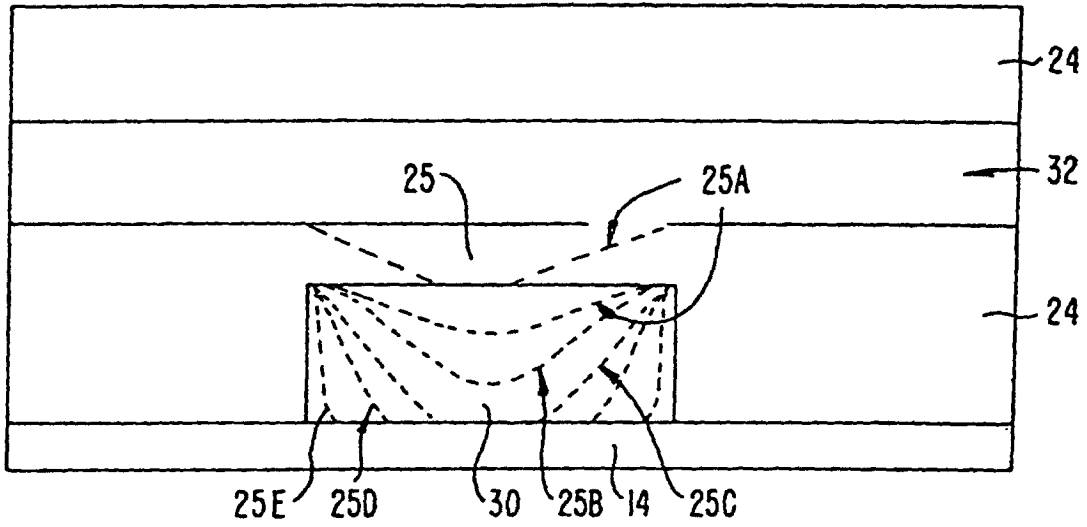

FIG. 19.

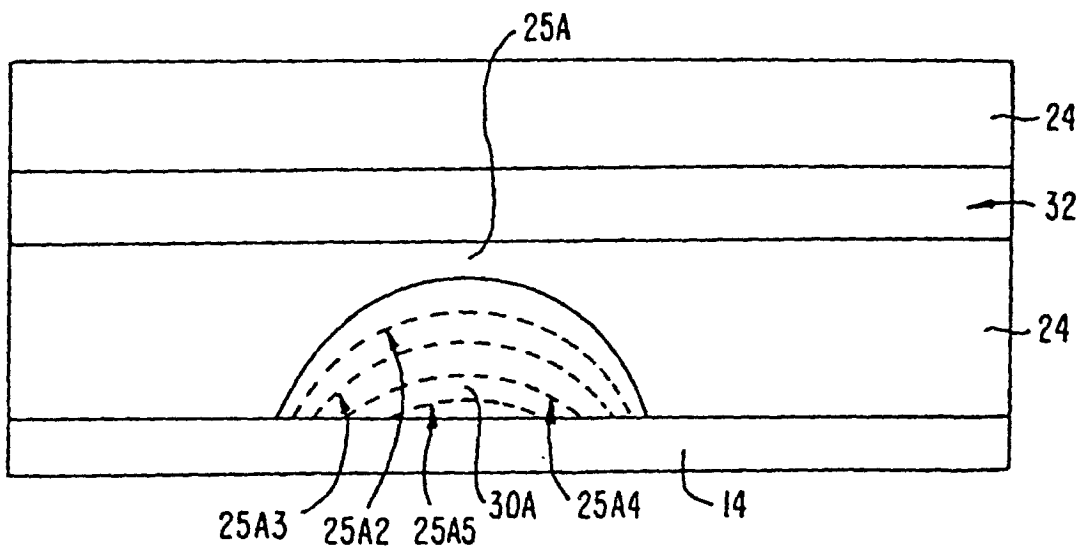

FIG. 20.

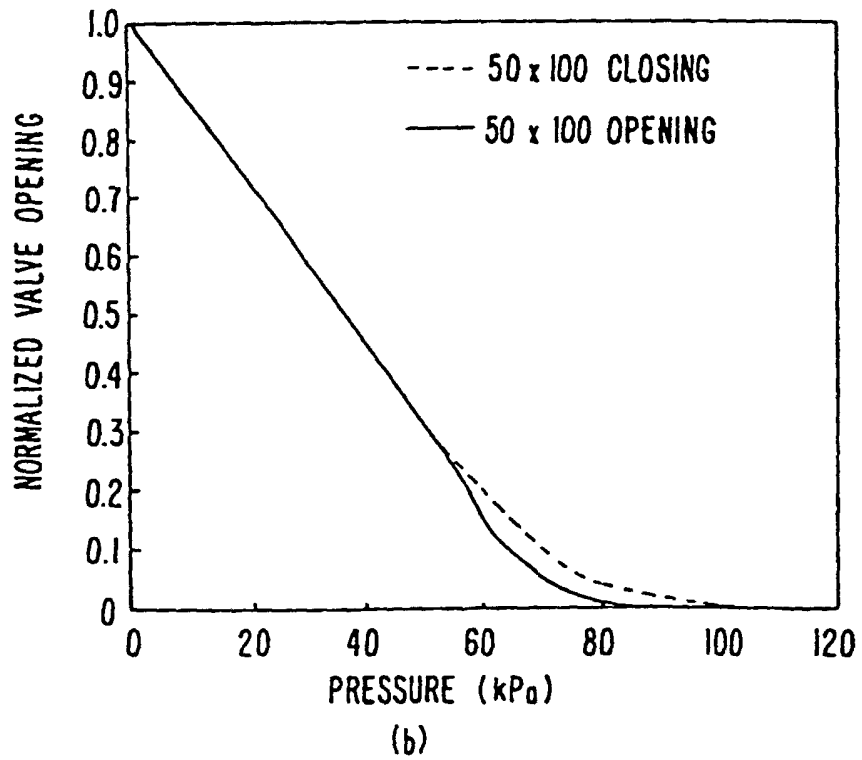
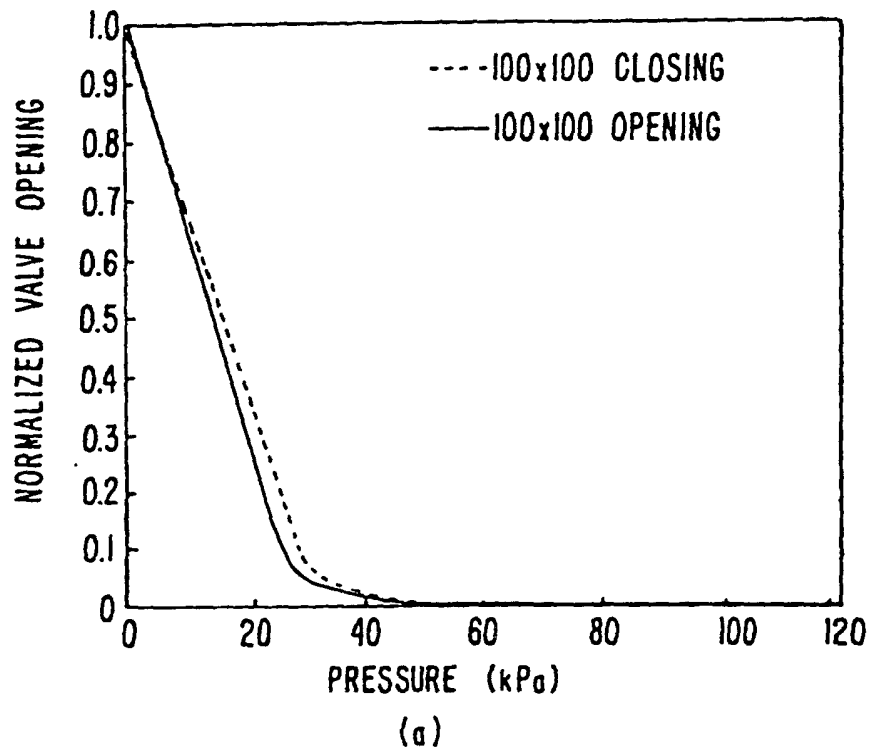

FIG. 21.

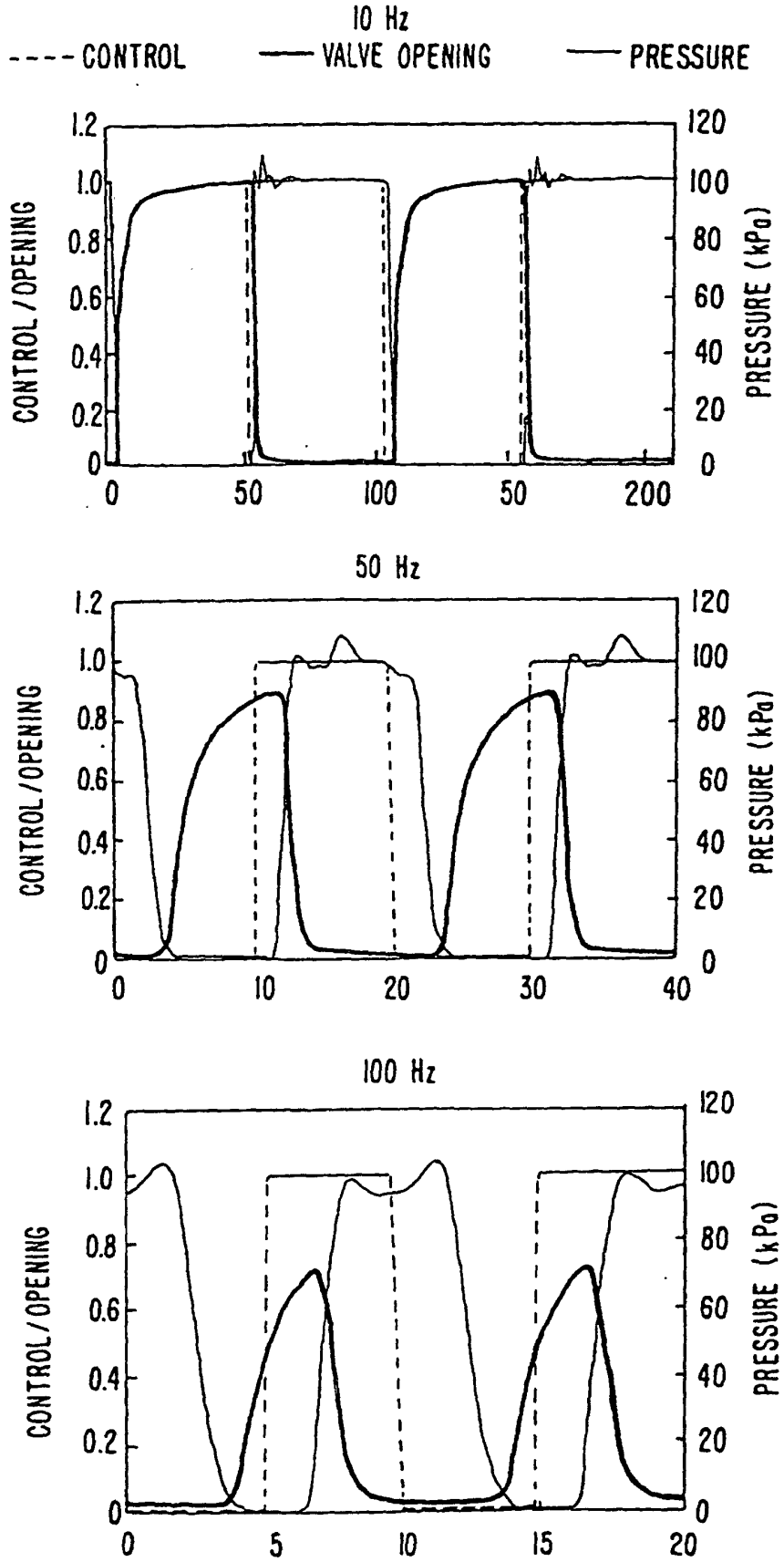

FIG. 22.

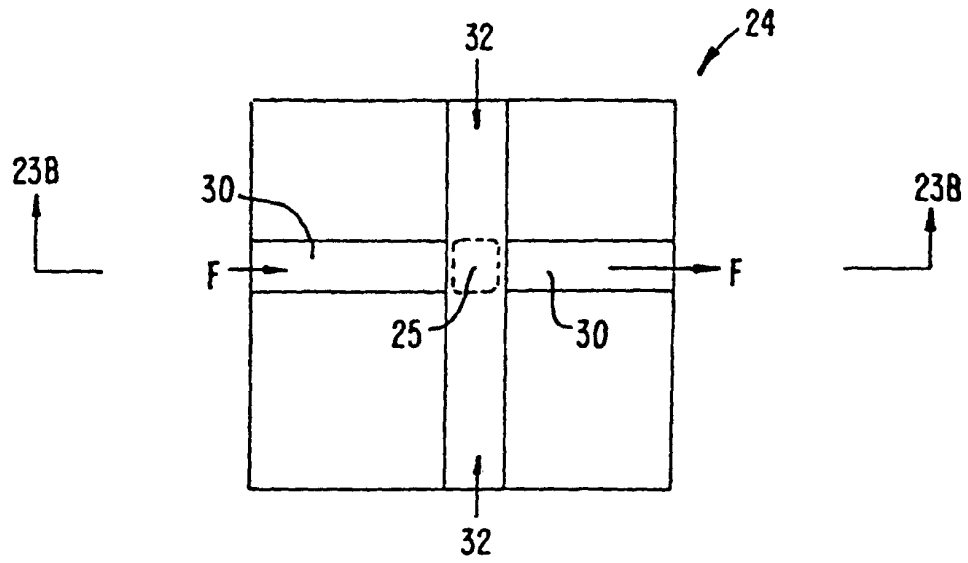

FIG. 23A.

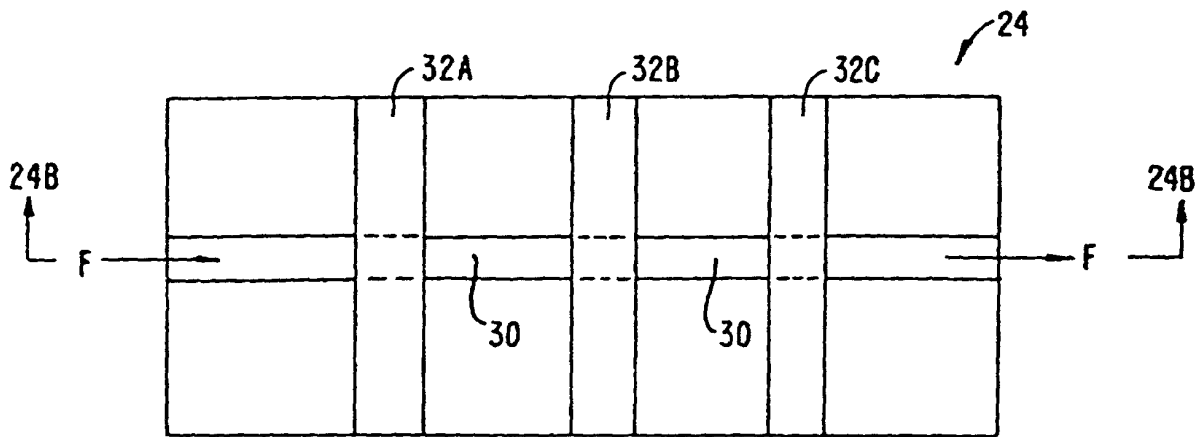

FIG. 24A.

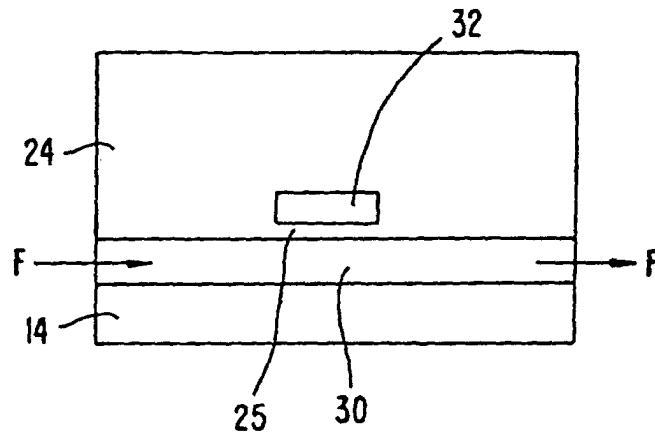

FIG. 23B.

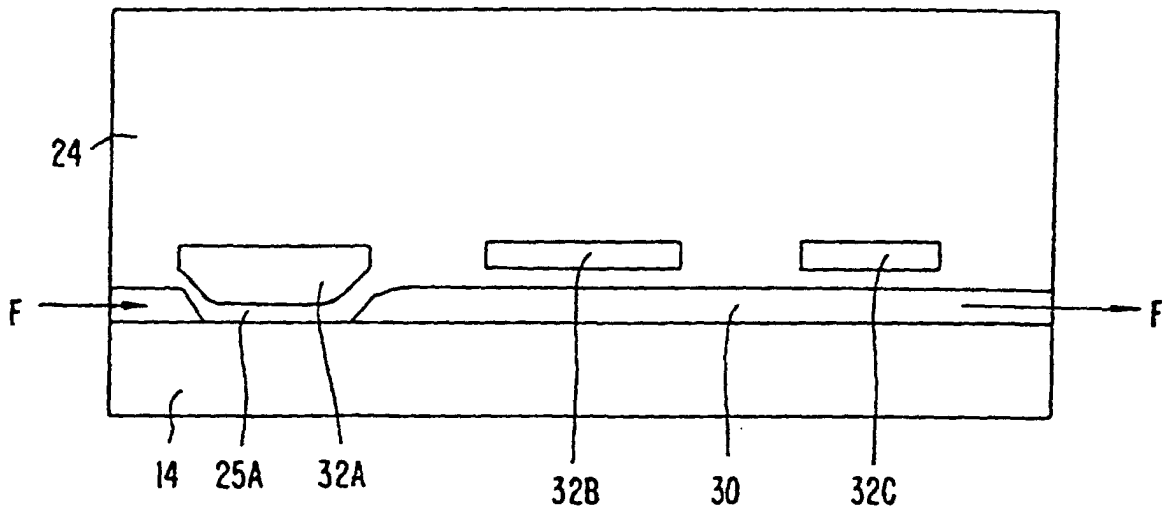

FIG. 24B.

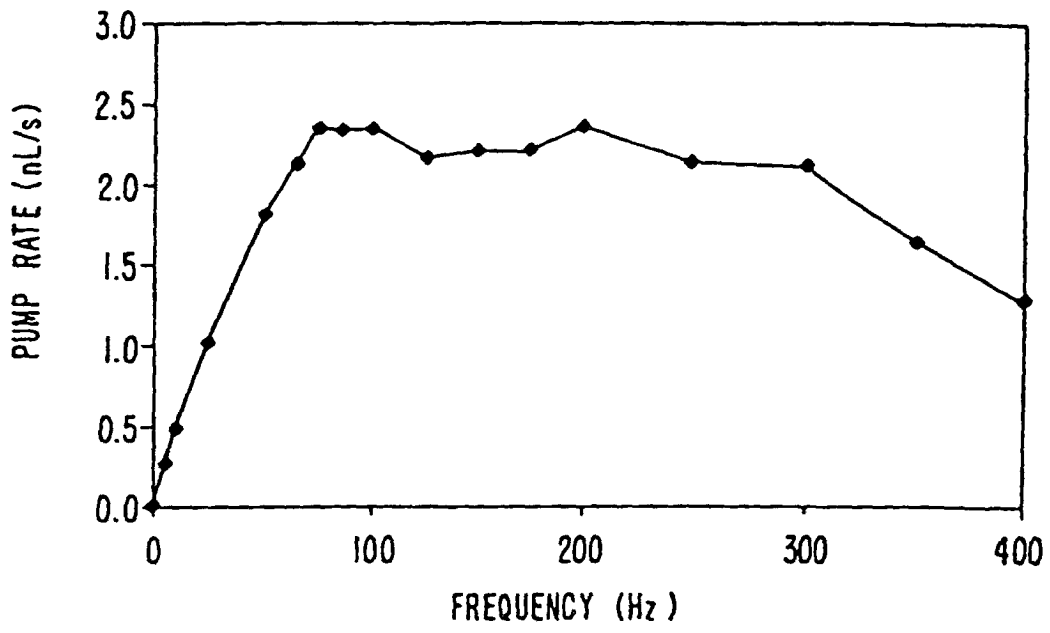

FIG. 25.

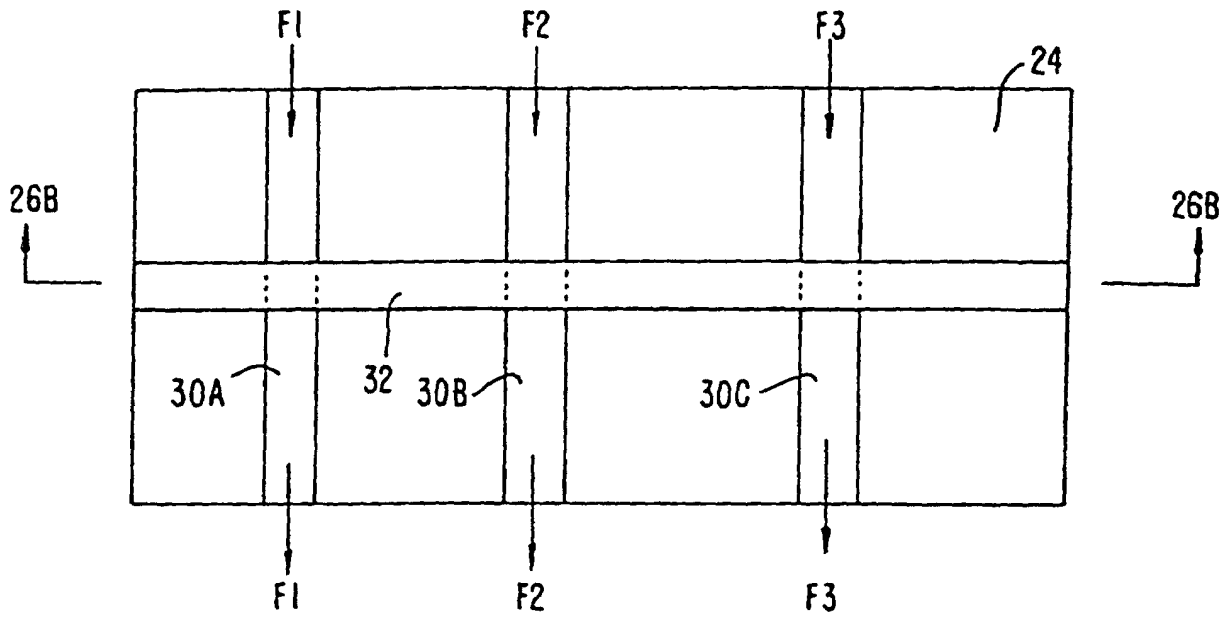

FIG. 26A.

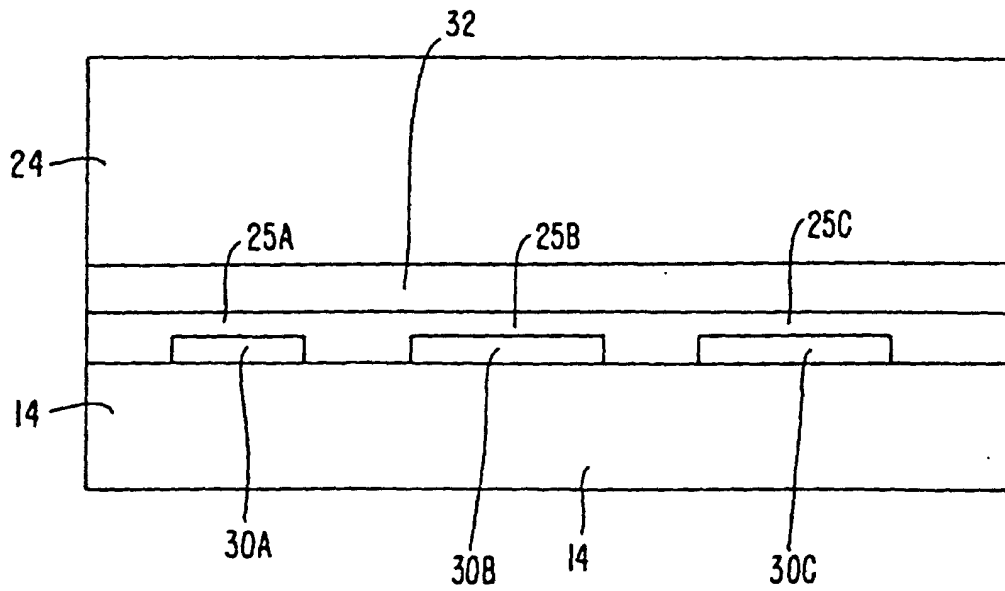

FIG. 26B.

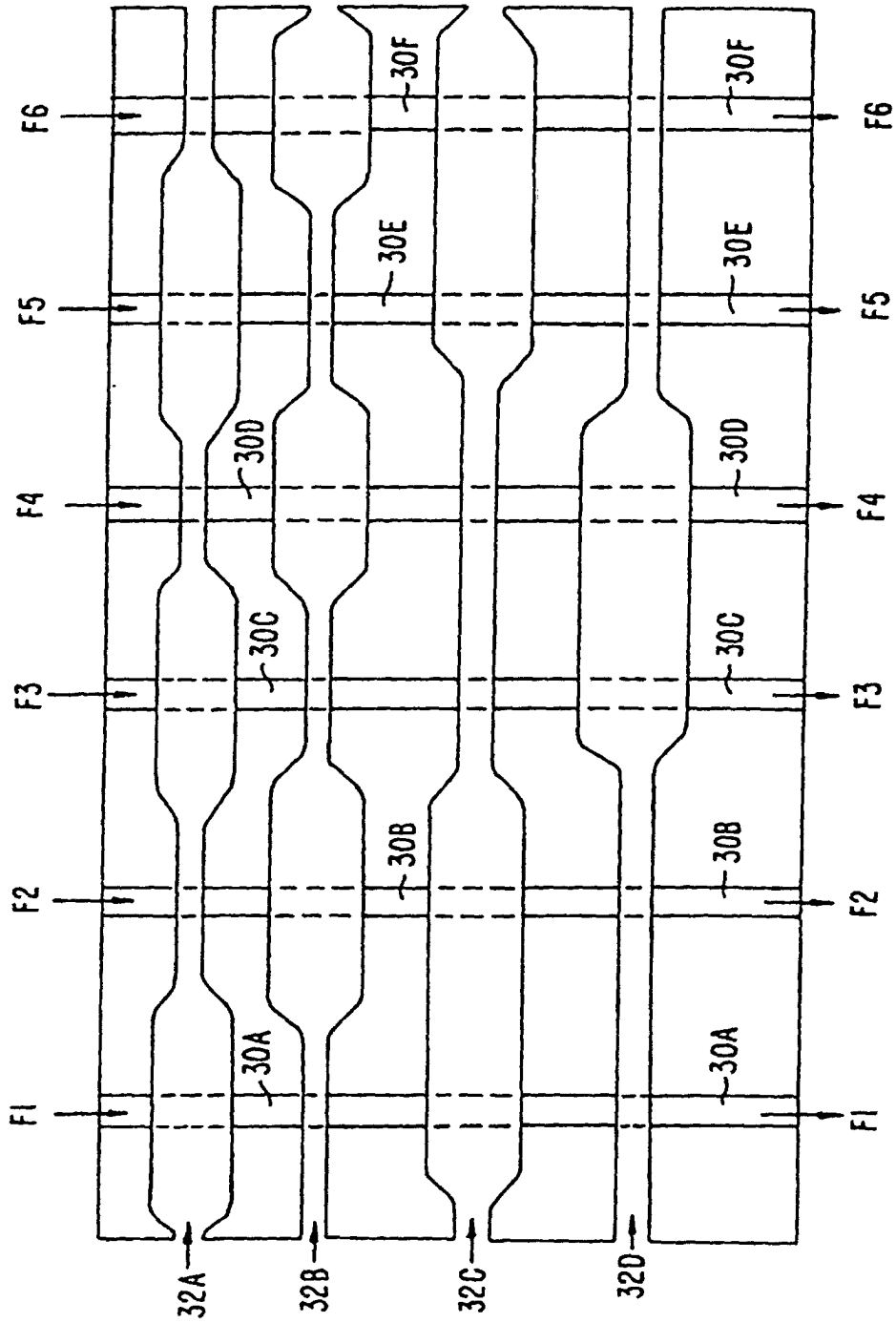

FIG. 27.

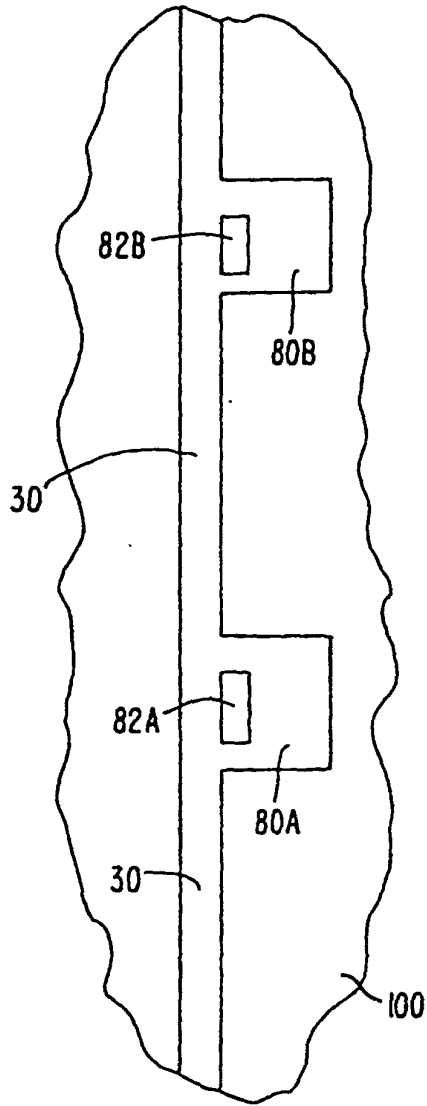

FIG. 28A.

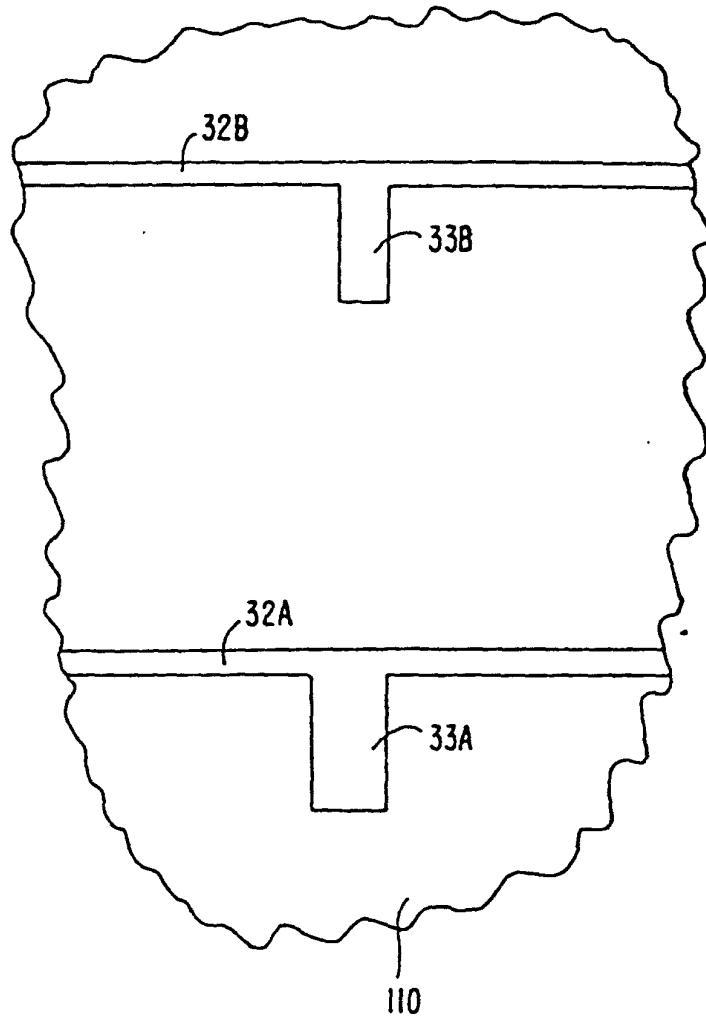

FIG. 28B.

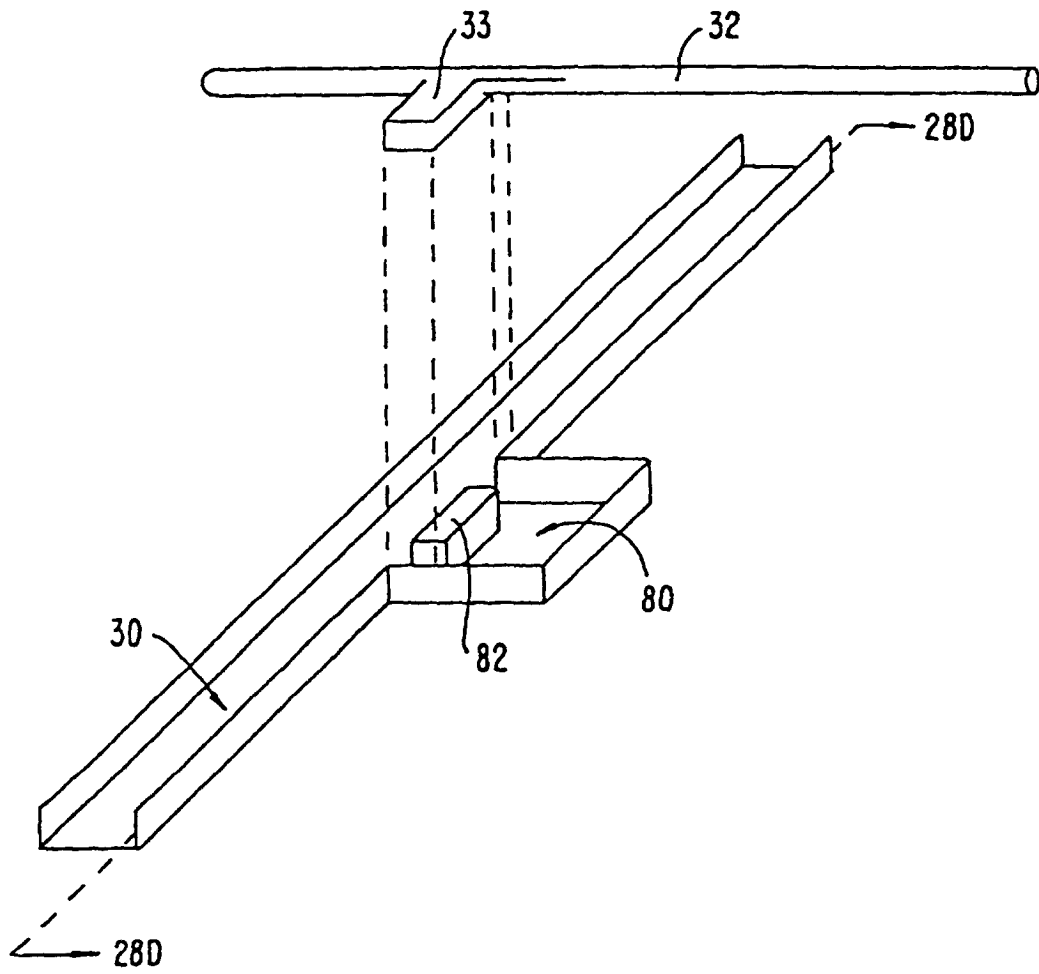

FIG. 28C.

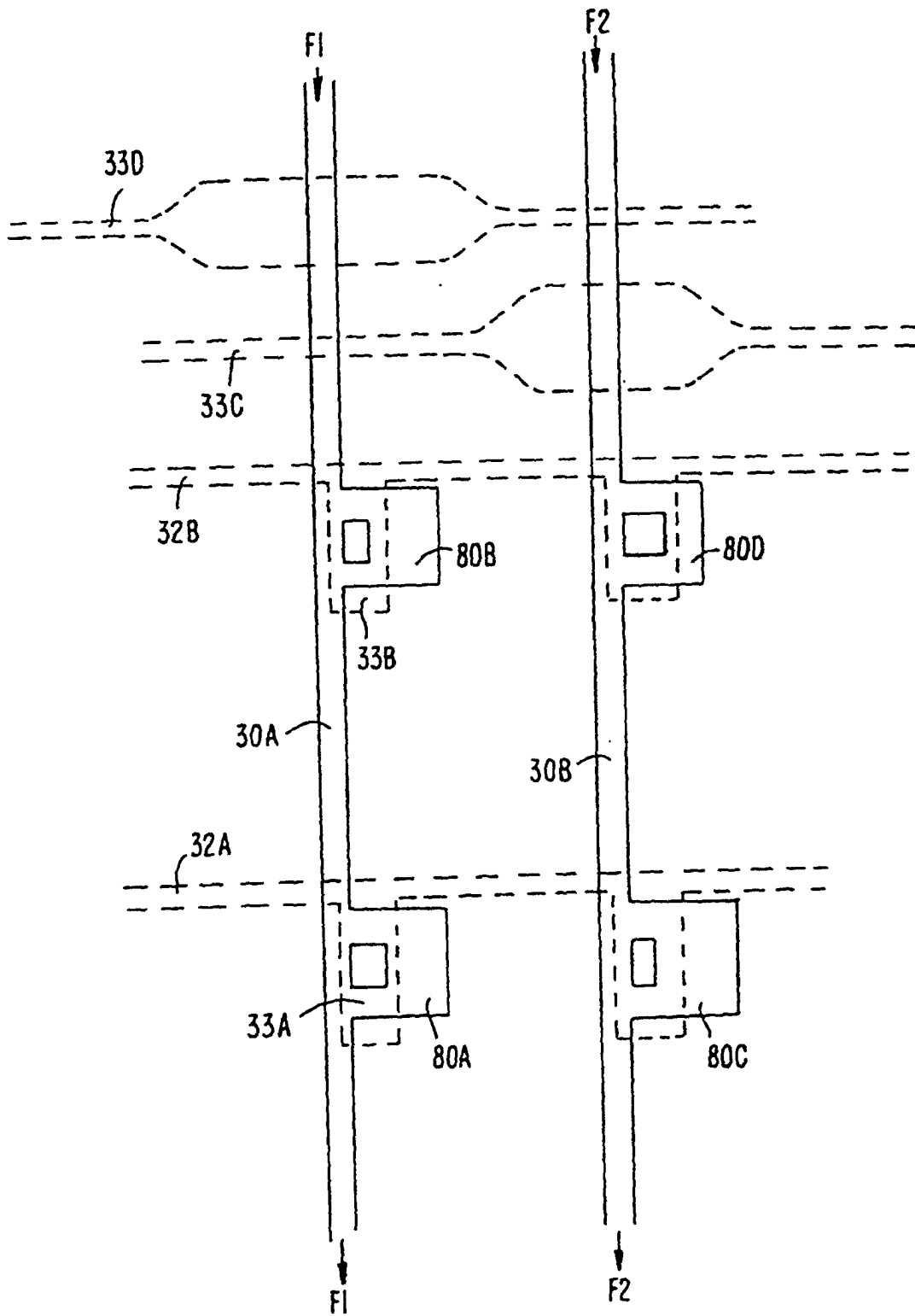

FIG. 29.

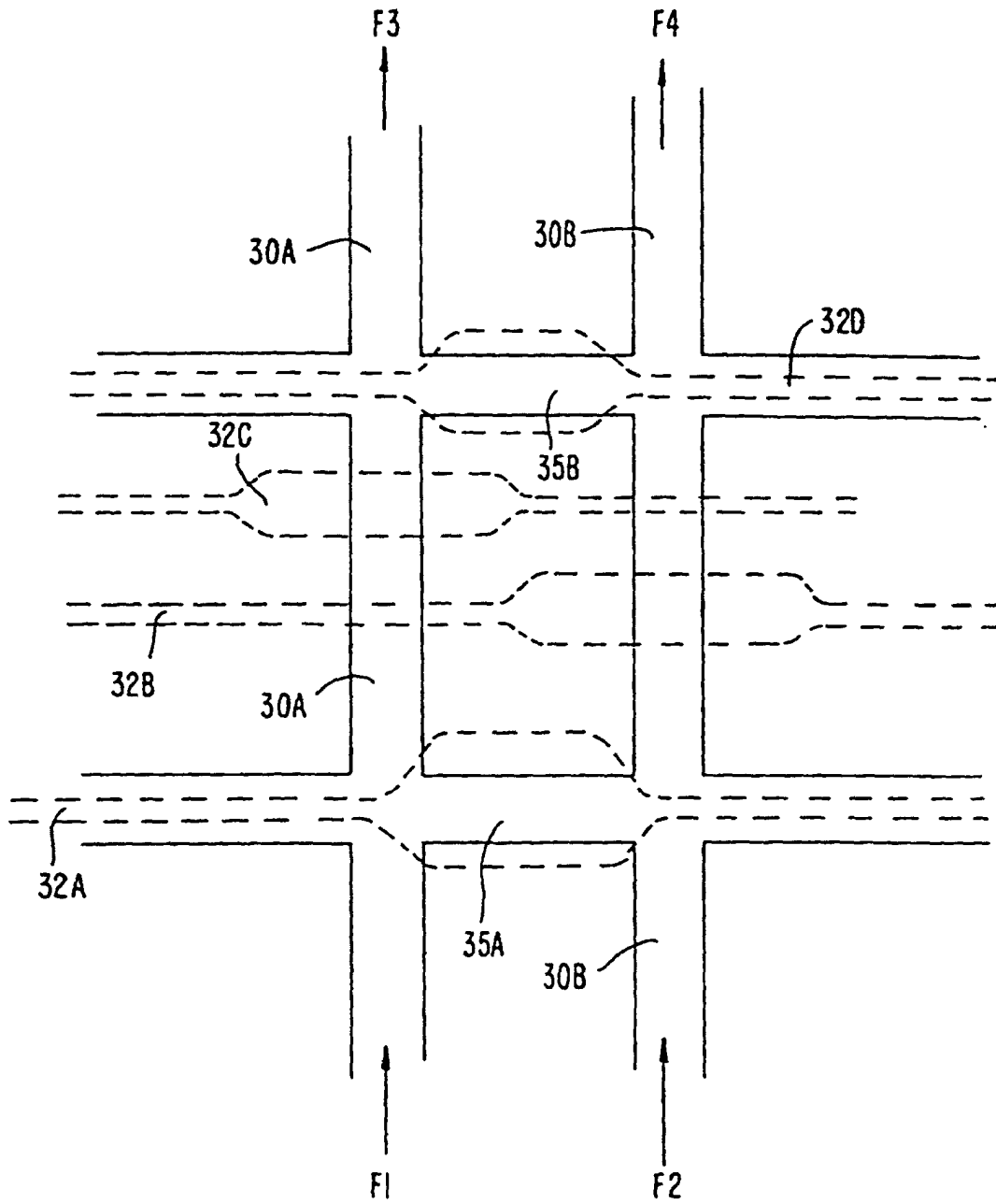

FIG. 30.

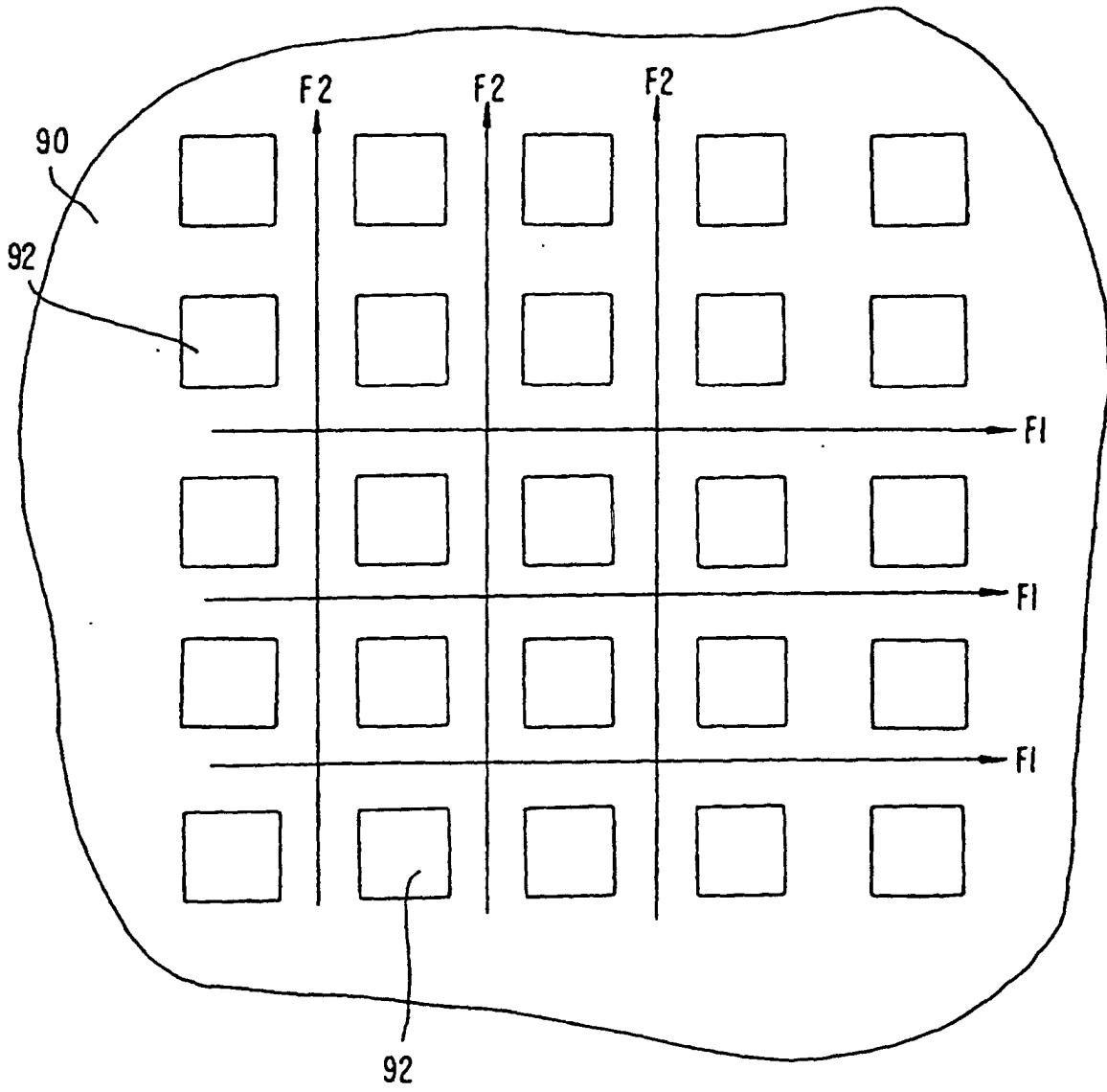

FIG. 31A.

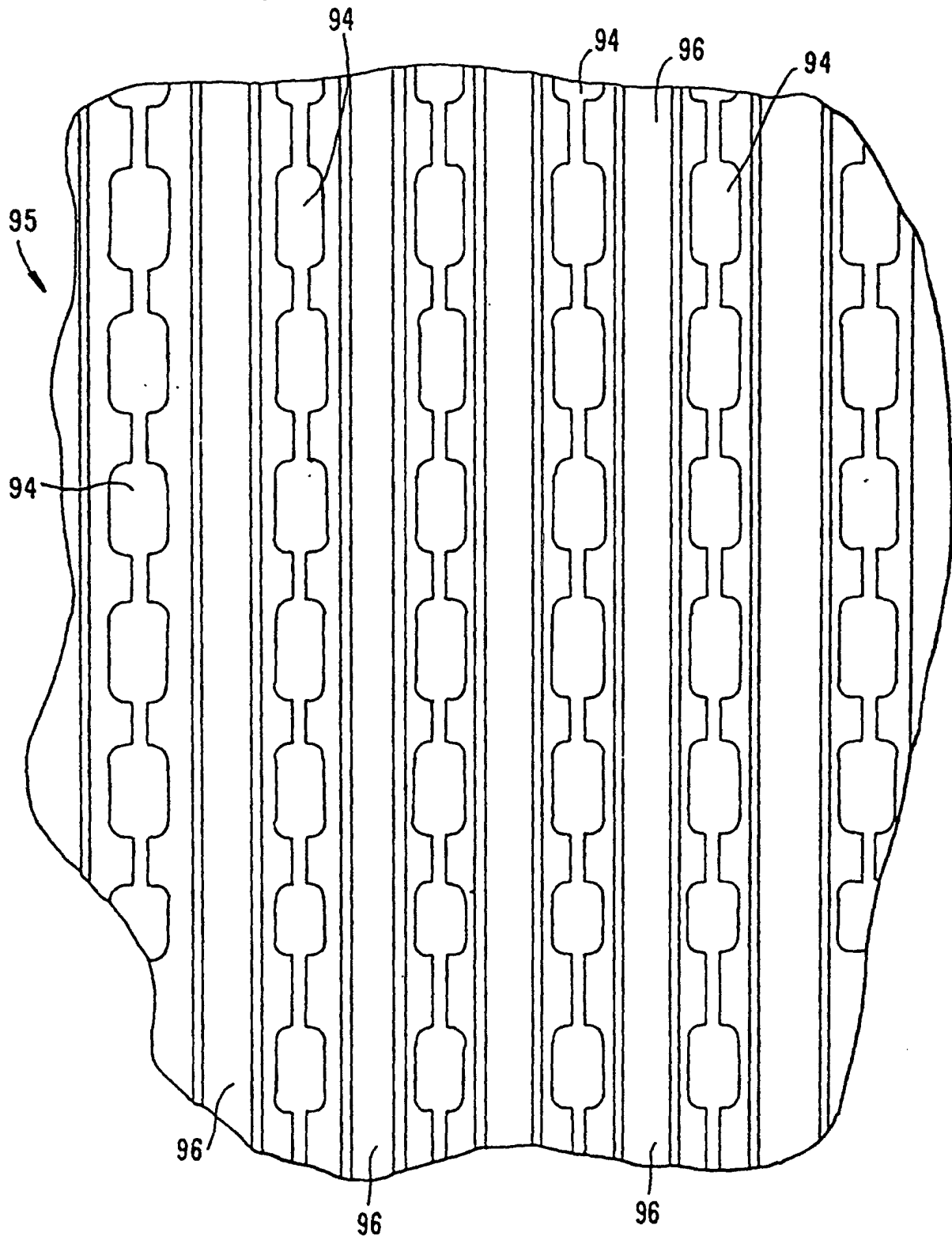

FIG. 3IB.

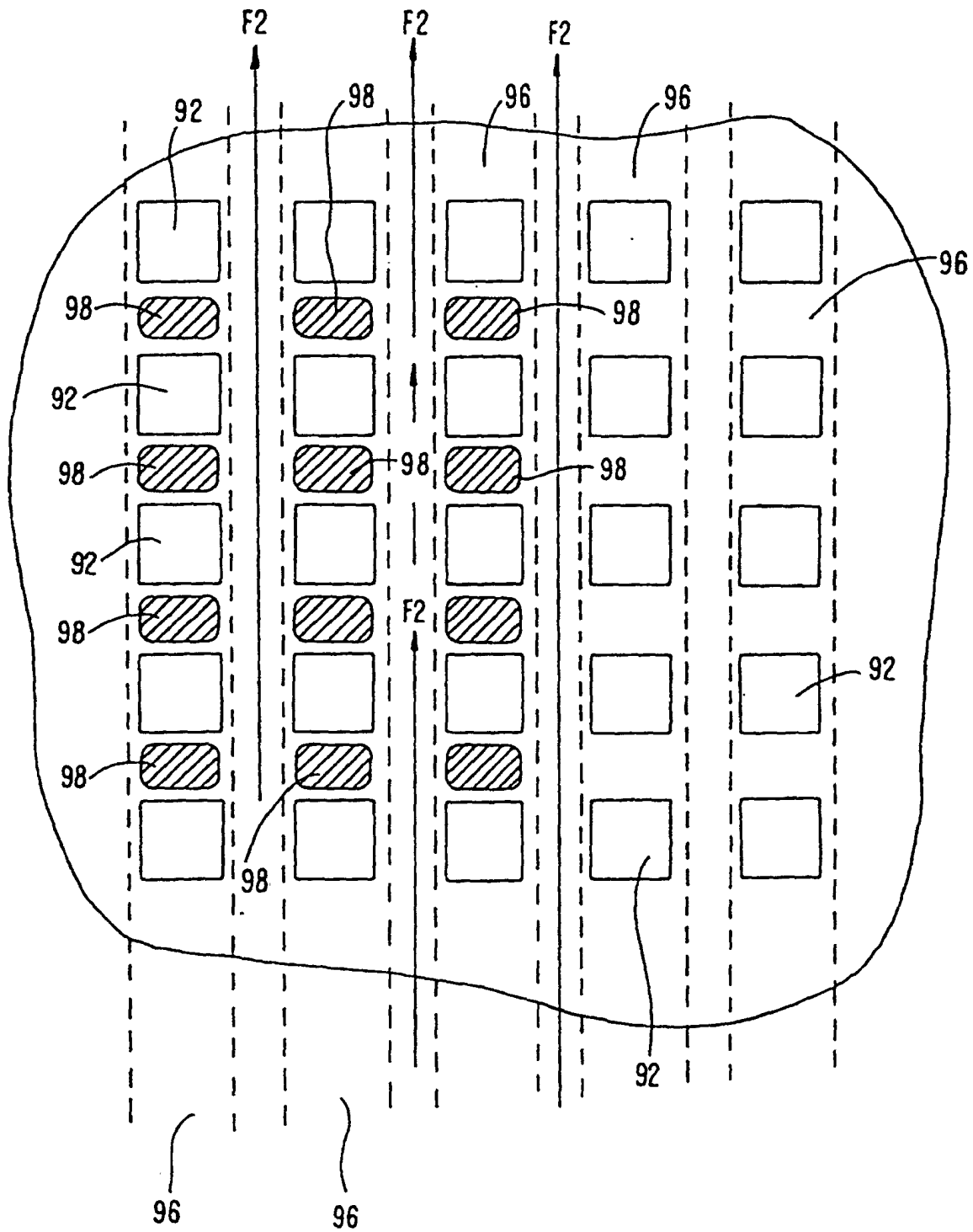

FIG. 31C.

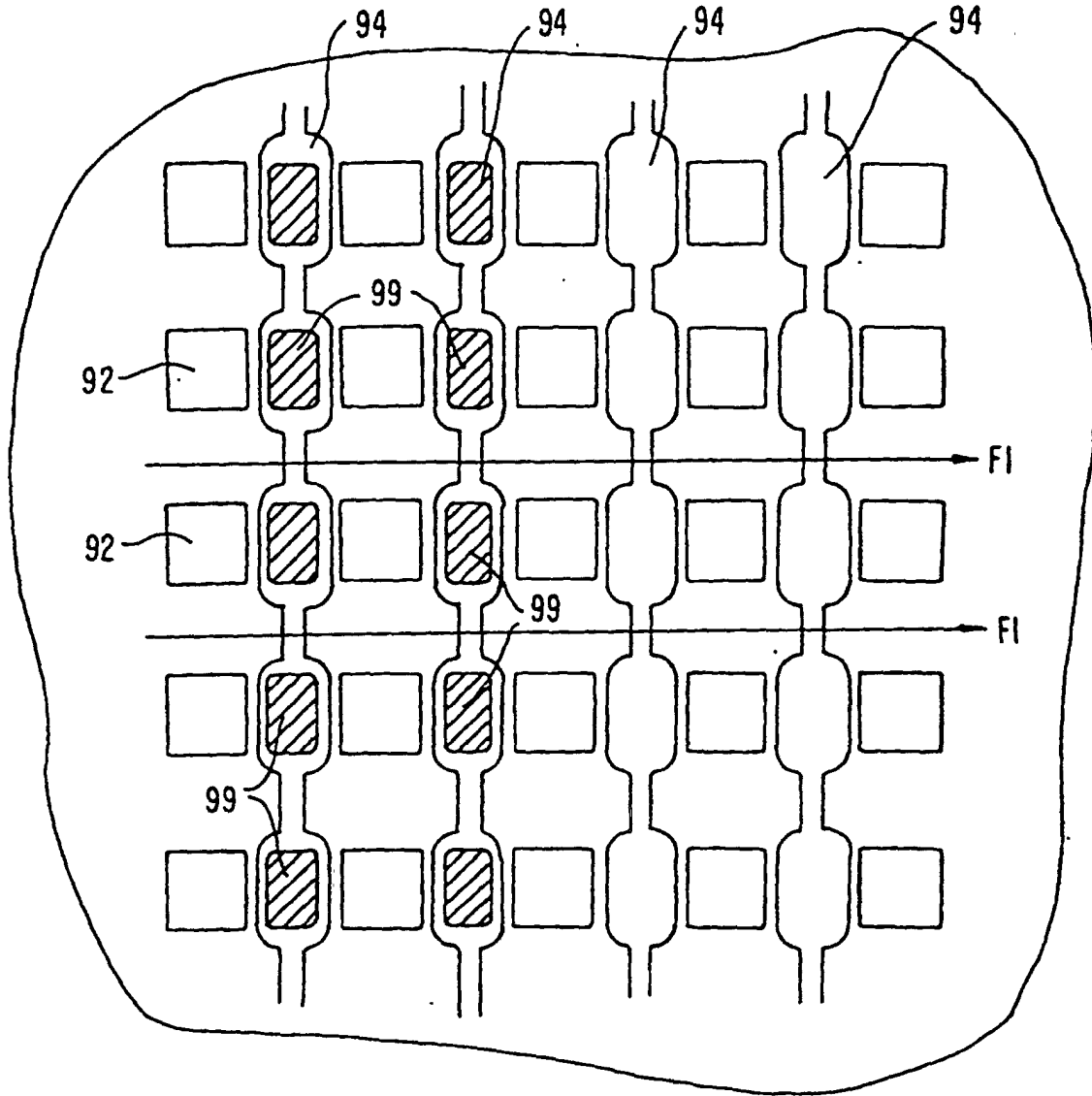

FIG. 31D.

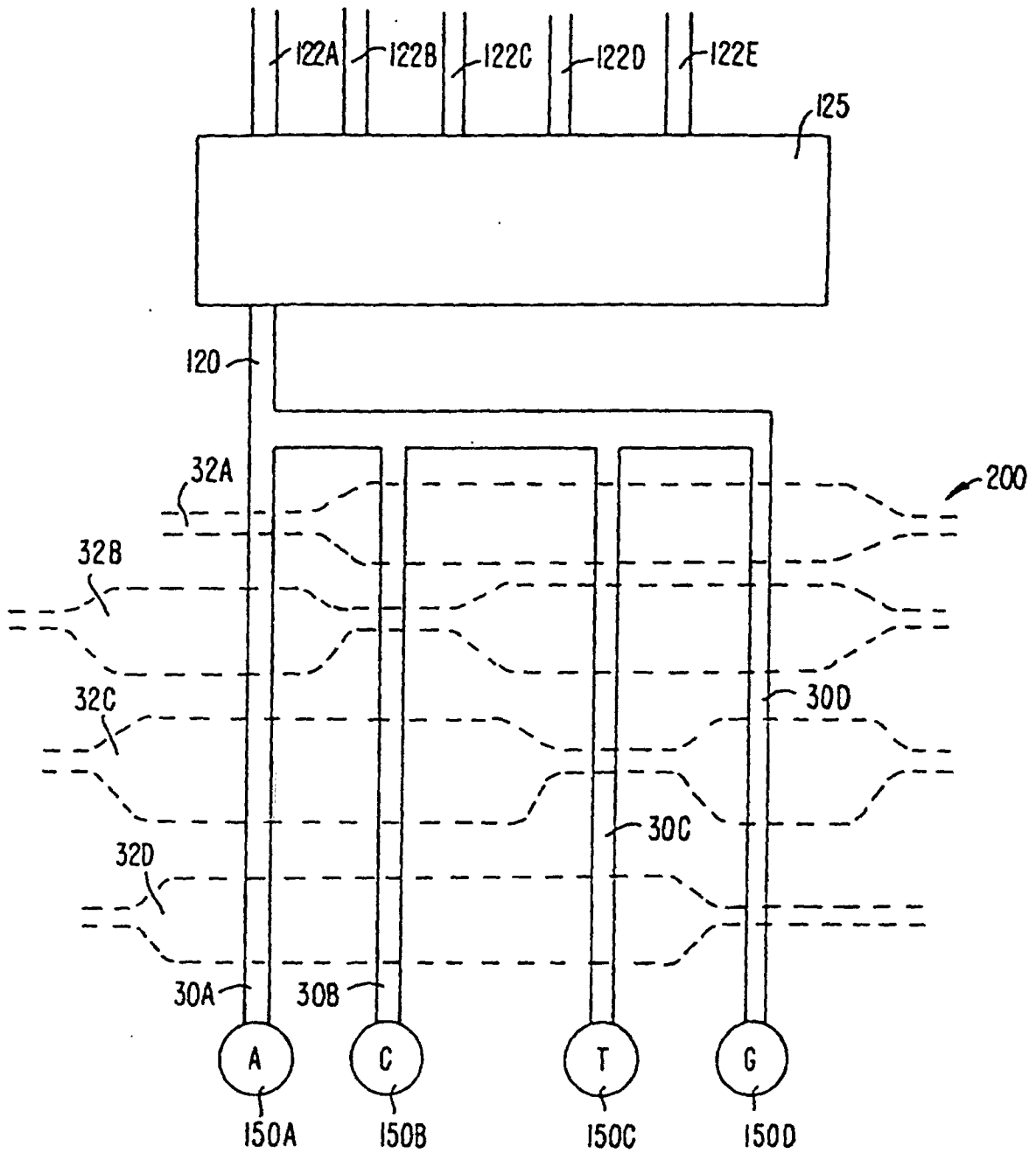

FIG. 32.

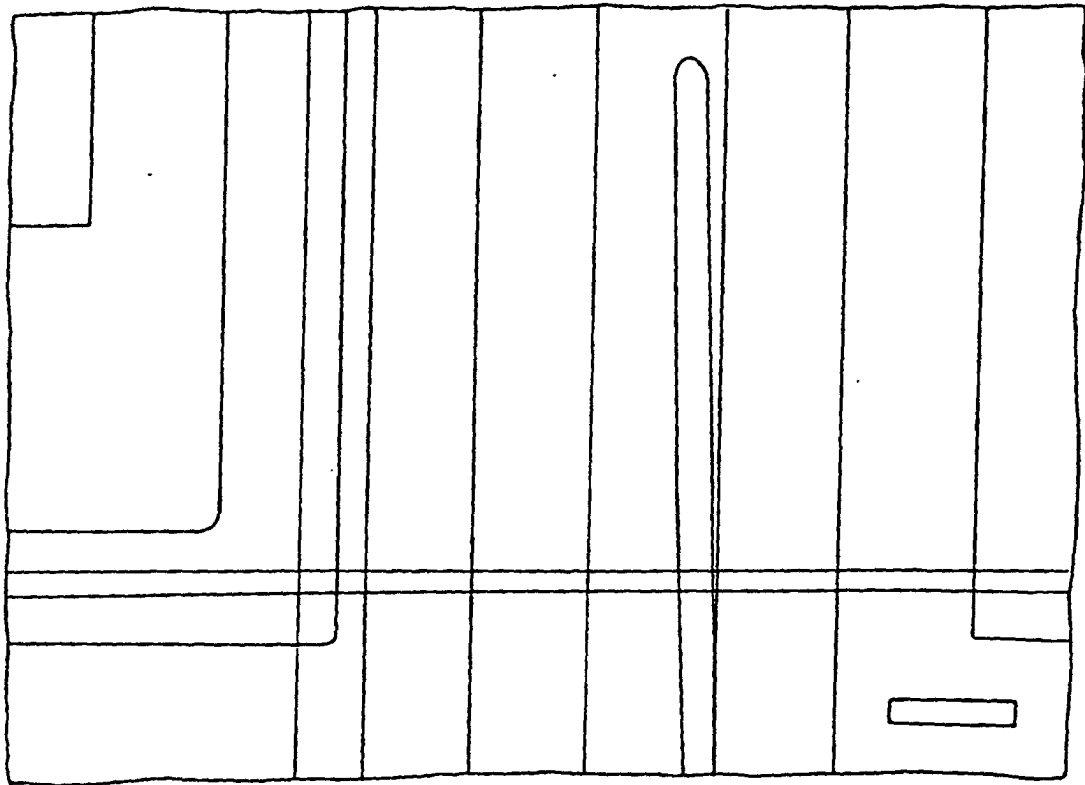
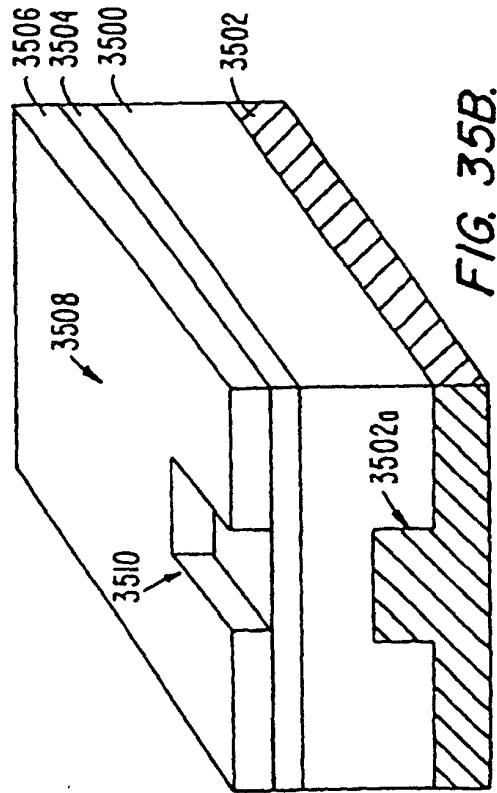
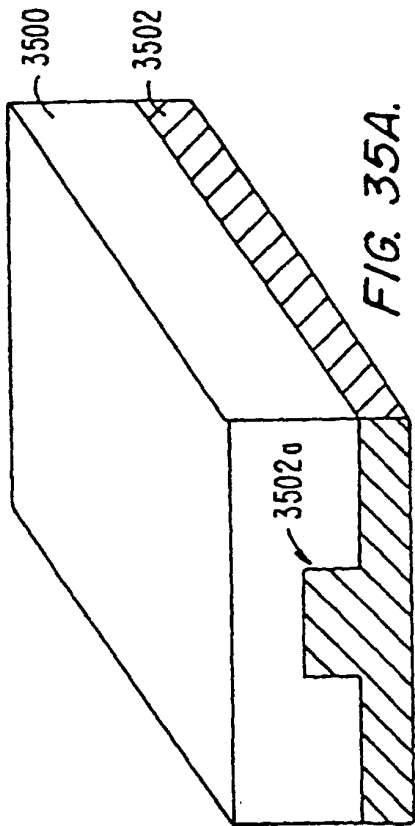
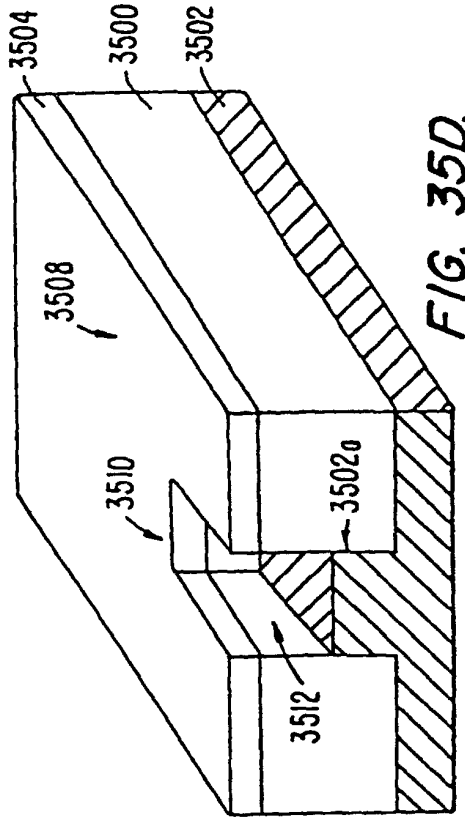
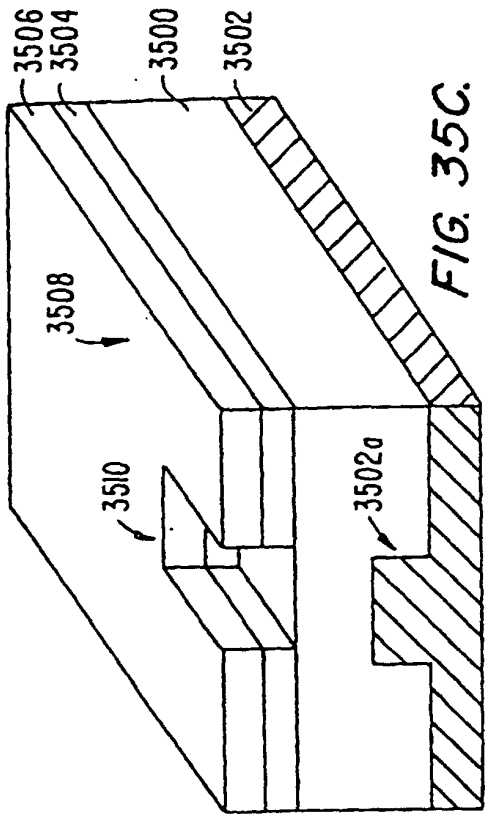

FIG. 34.



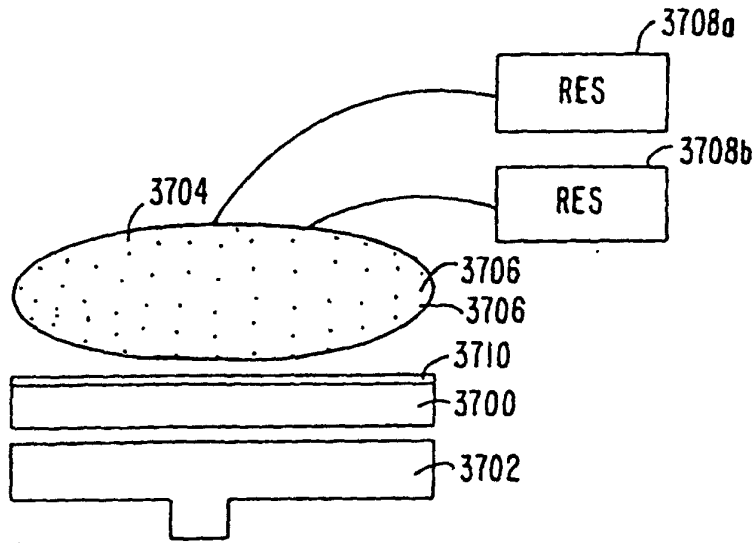

FIG. 37.

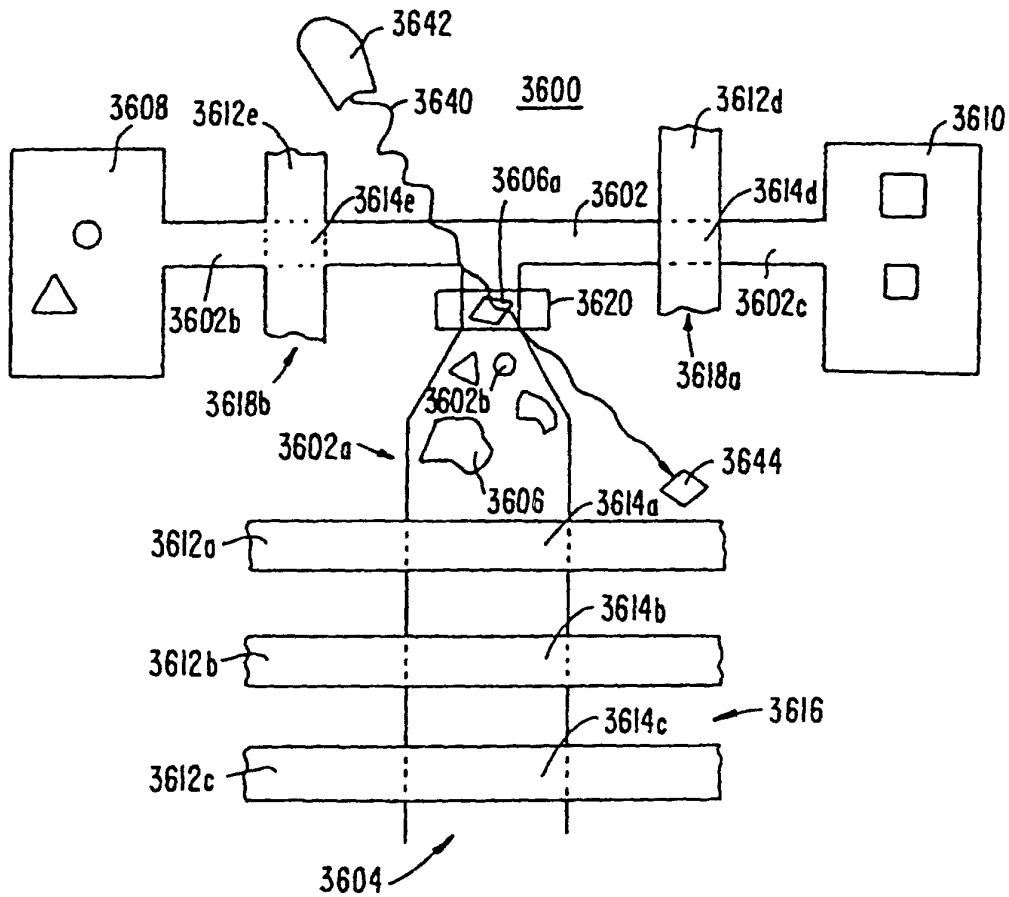
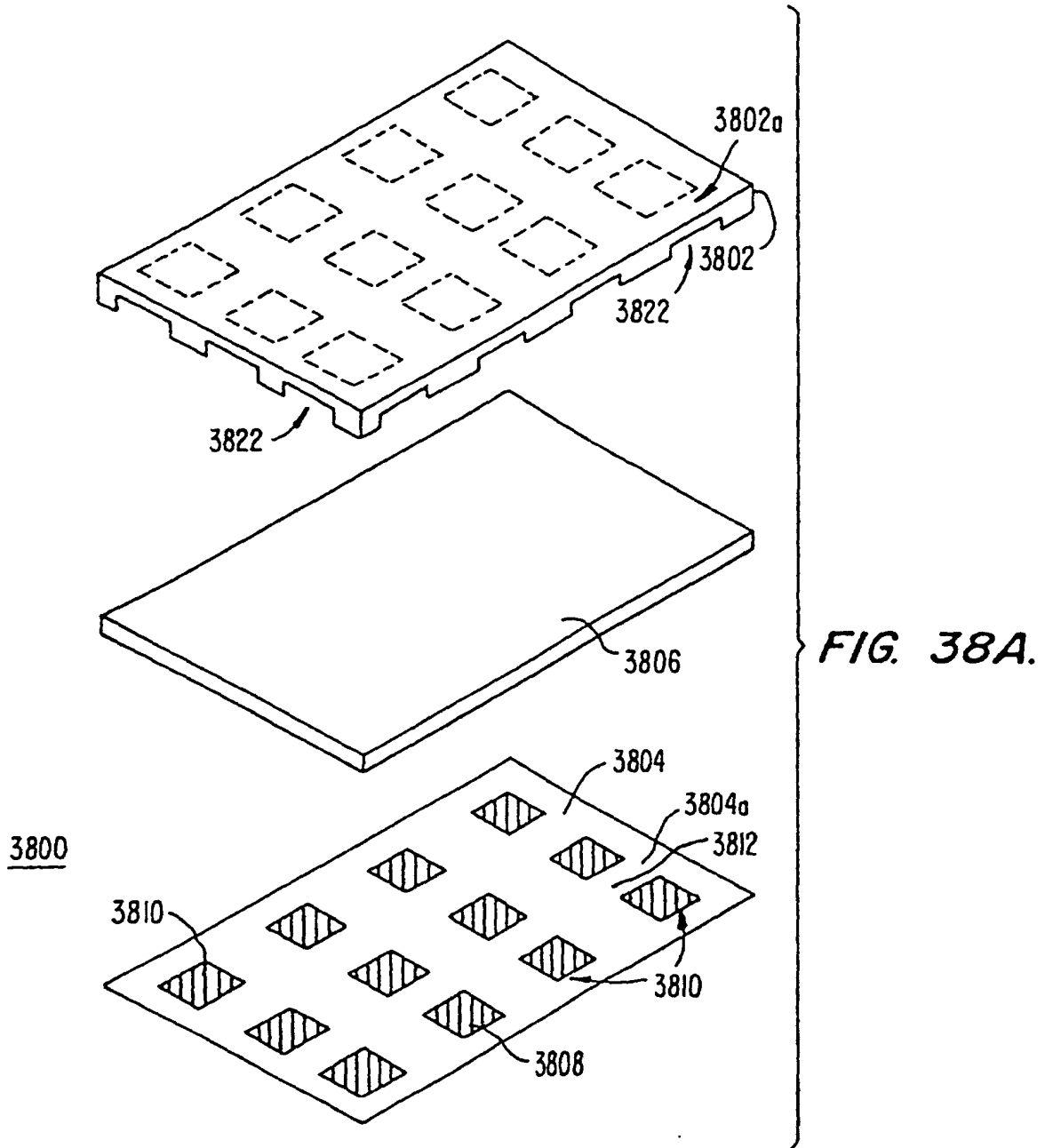

FIG. 36.



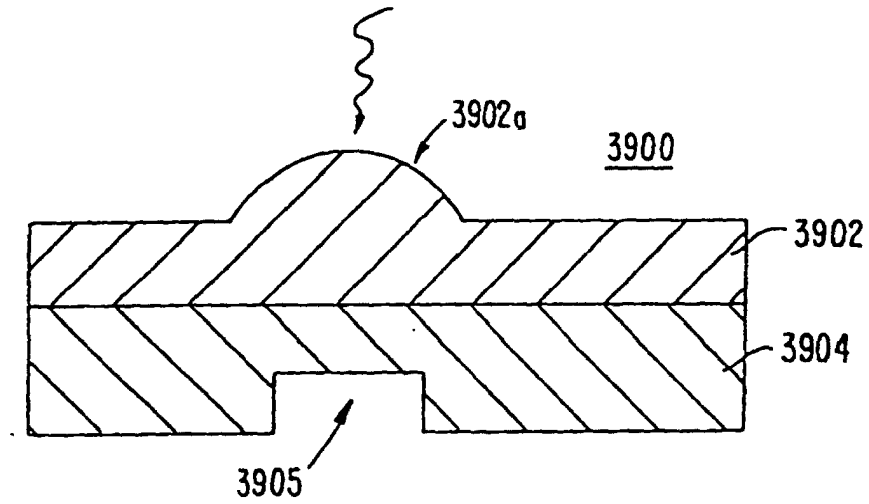

FIG. 39.

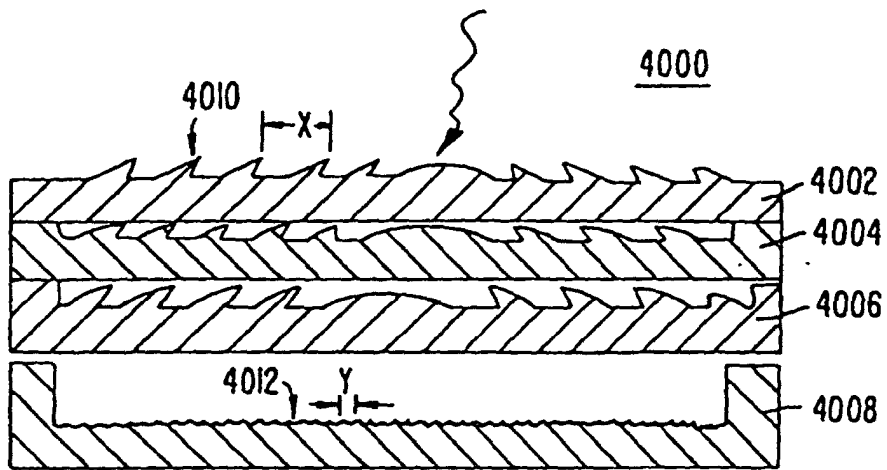

FIG. 40.

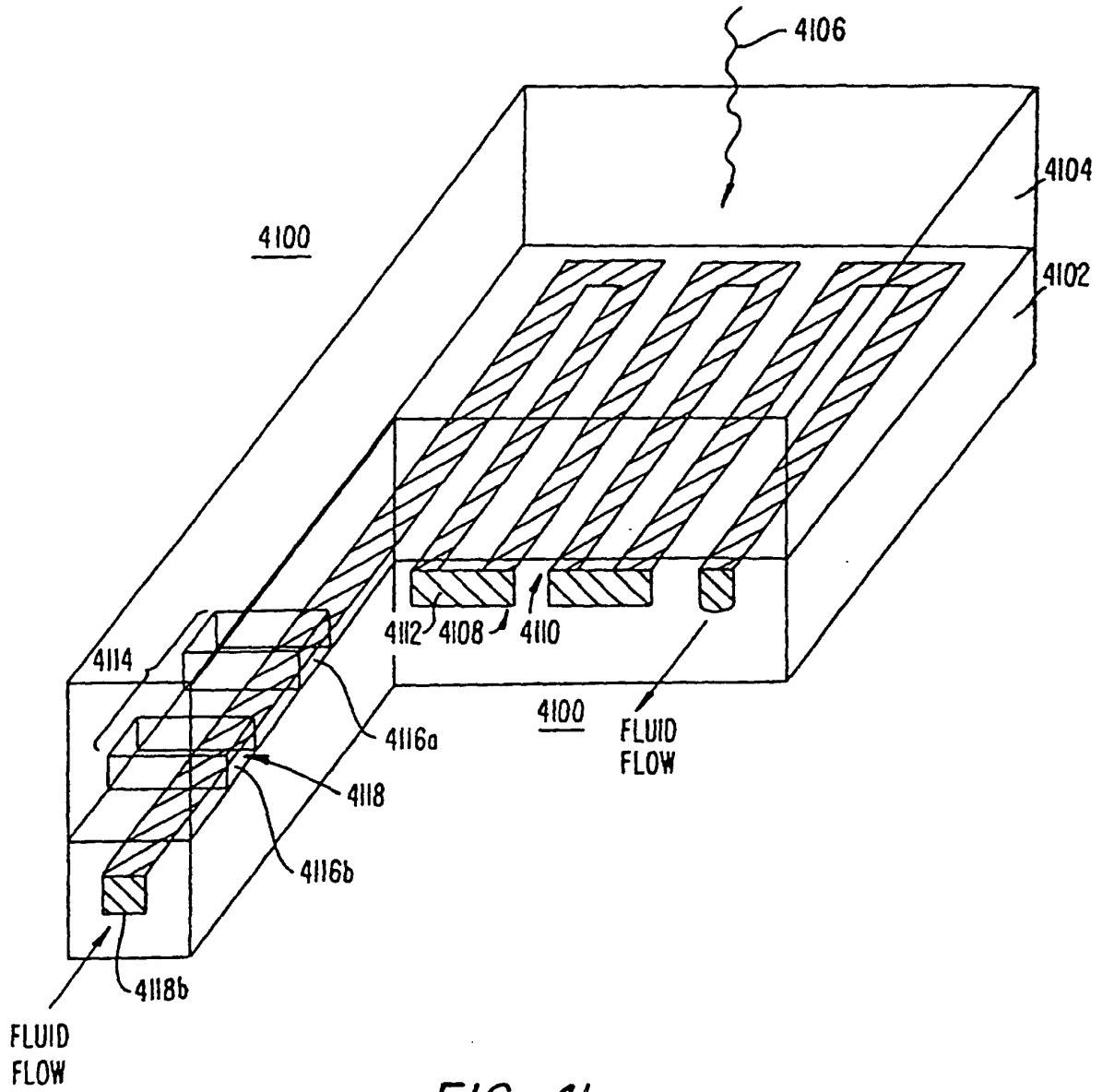

FIG. 41.

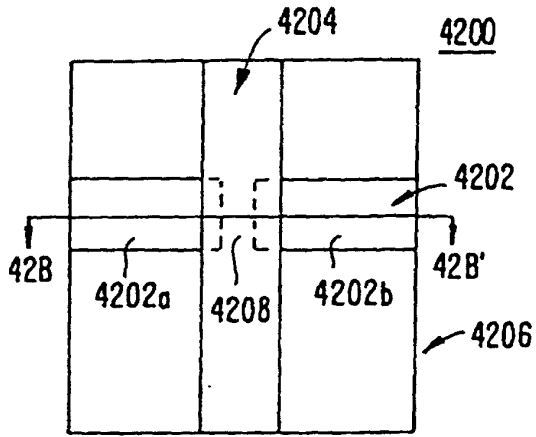

FIG. 42A.

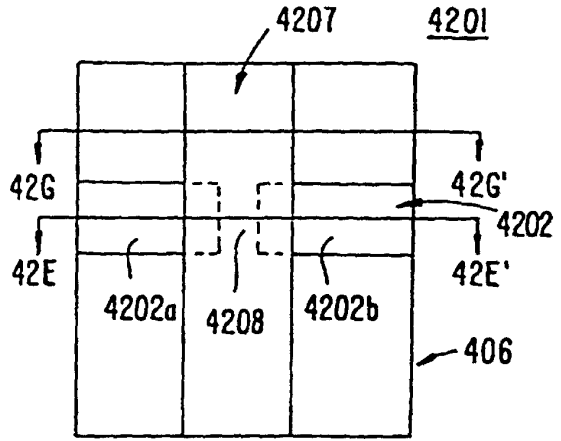

FIG. 42D.

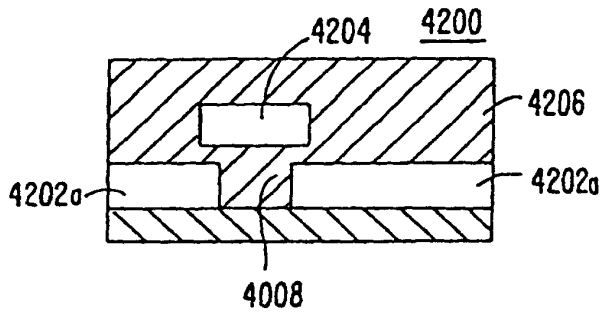

FIG. 42B.

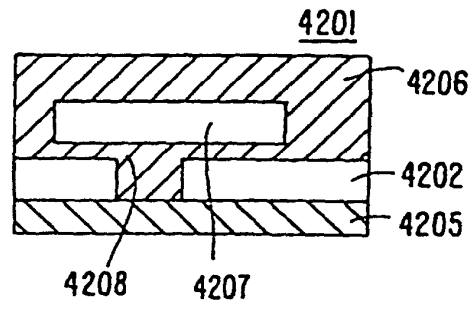

FIG. 42E.

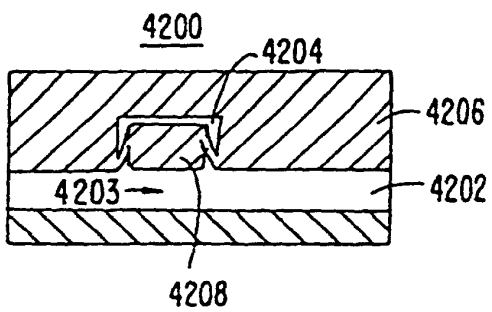

FIG. 42C.

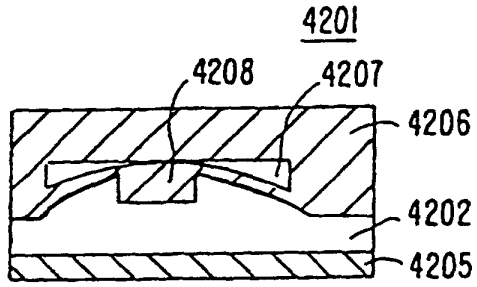

FIG. 42F.

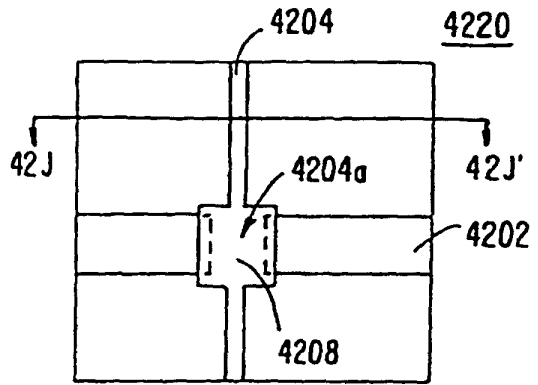

FIG. 42I.

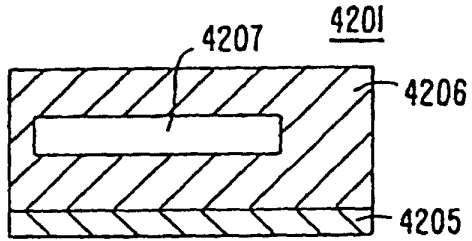

FIG. 42G.

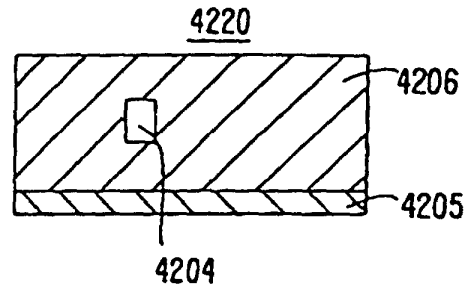

FIG. 42J.

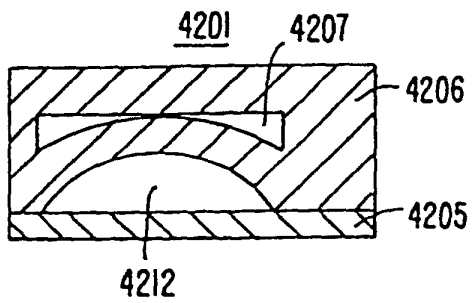

FIG. 42H.

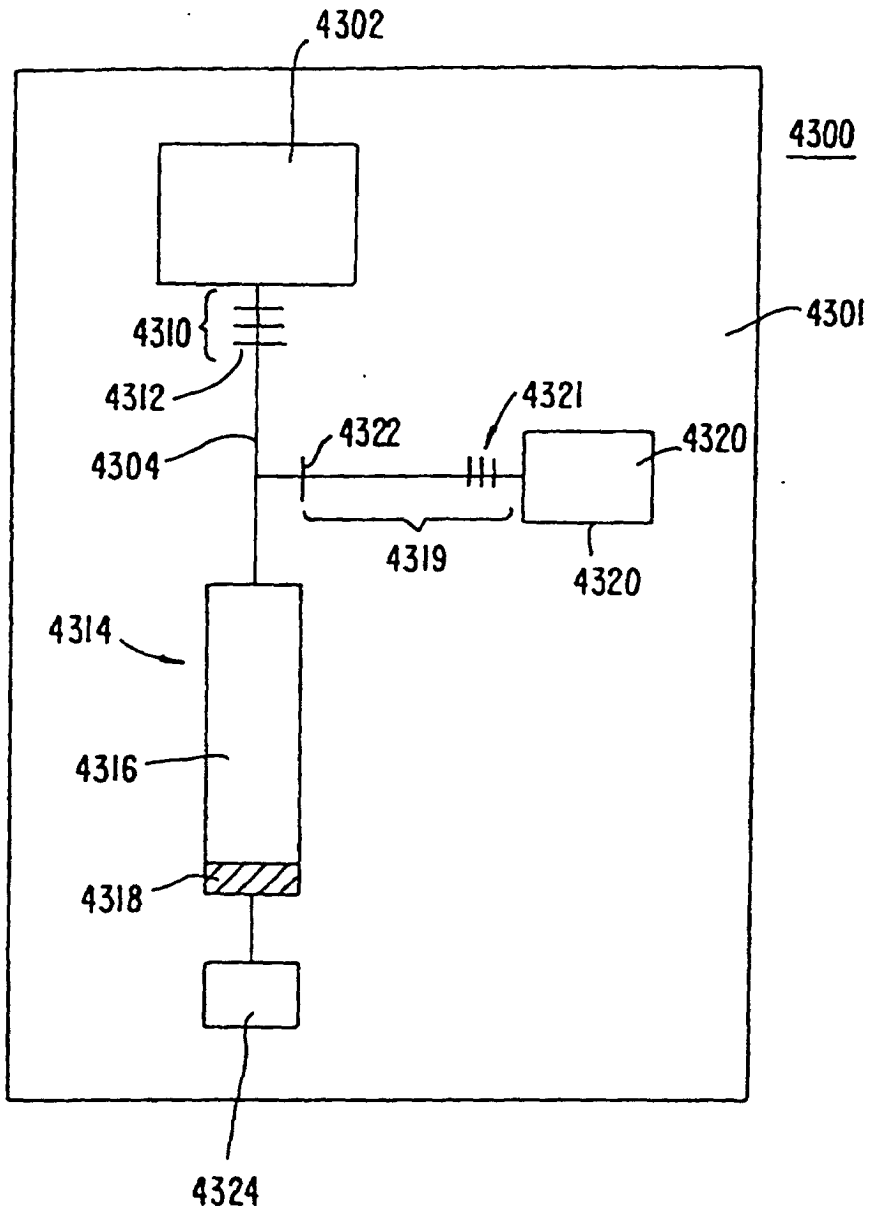

FIG. 43.

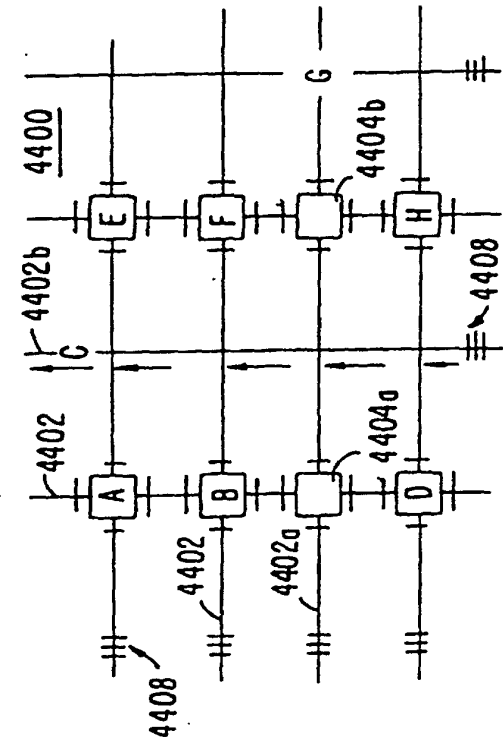

FIG 44C.

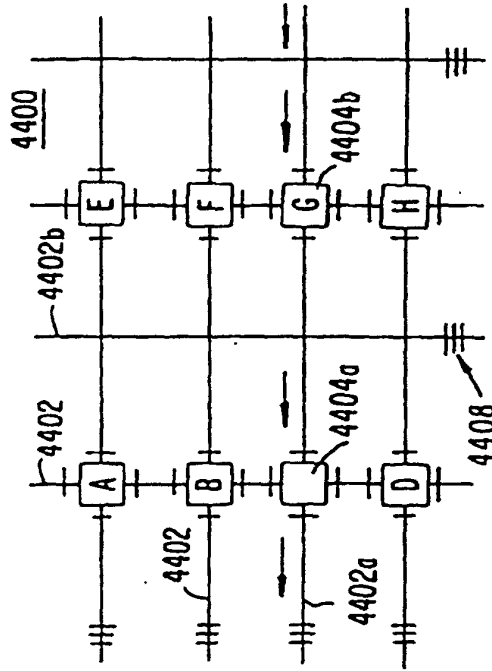

FIG 44D.

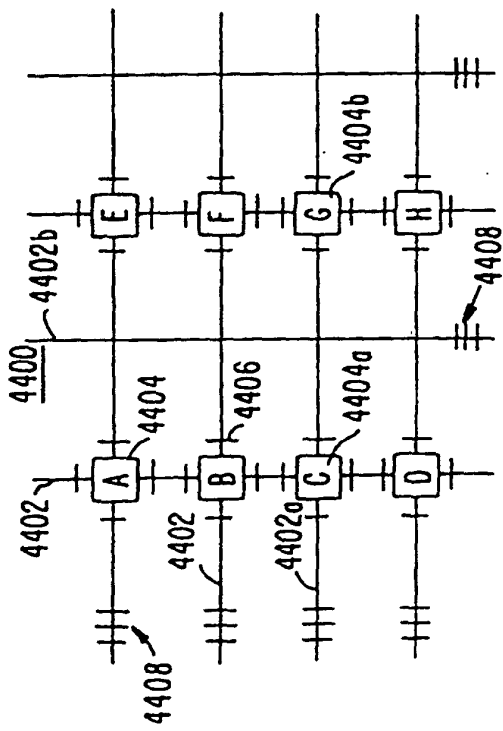

FIG 44A.

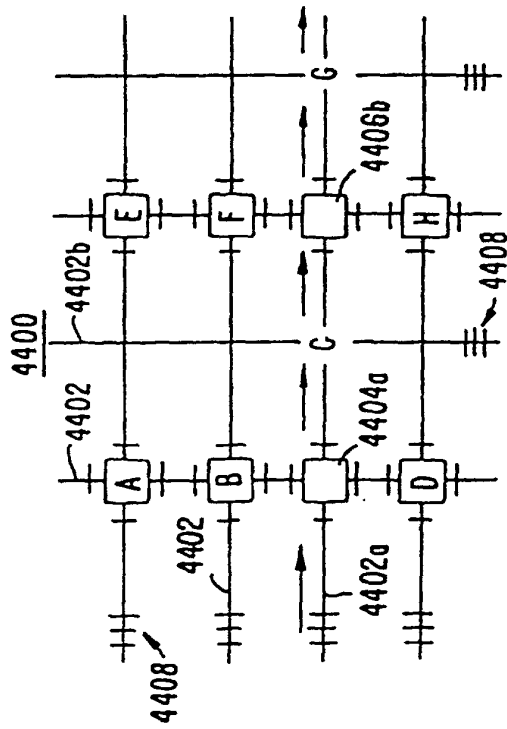

FIG 44B.

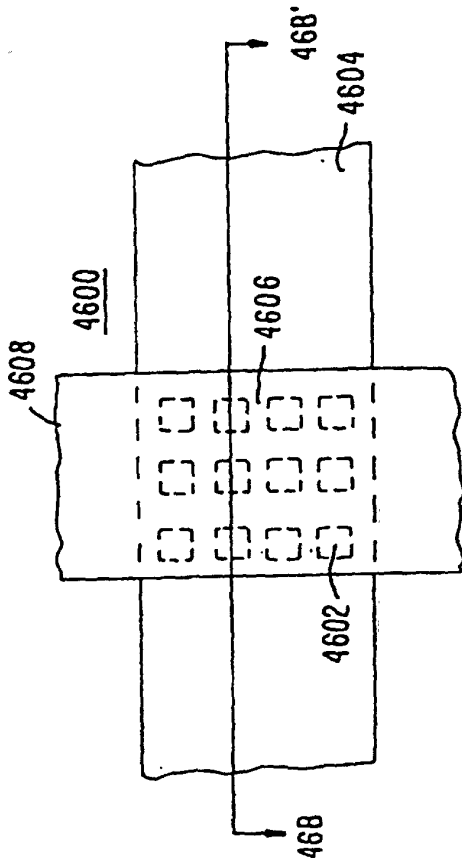

FIG. 46A.

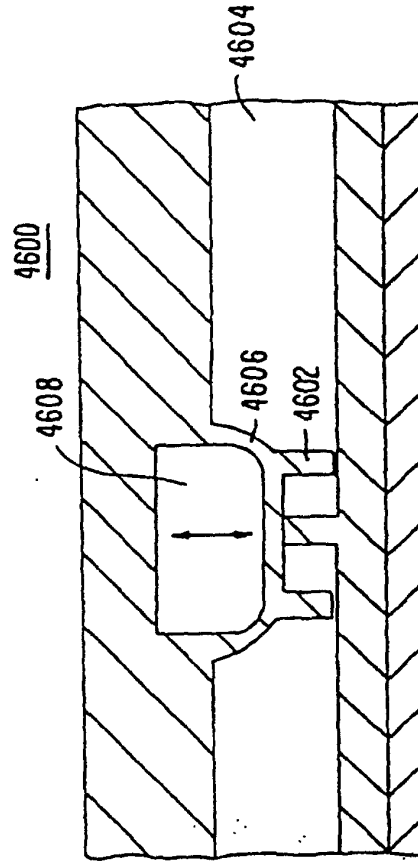

FIG. 46B.

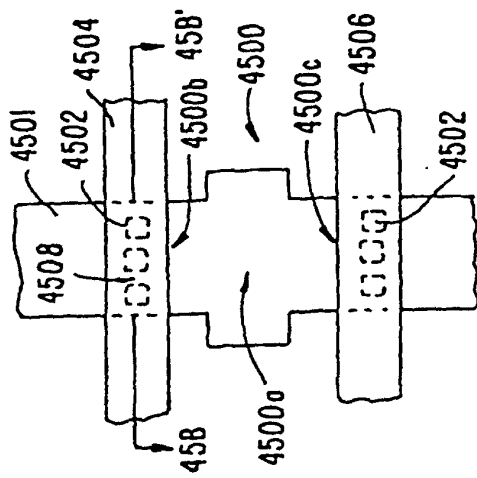

FIG. 45A.

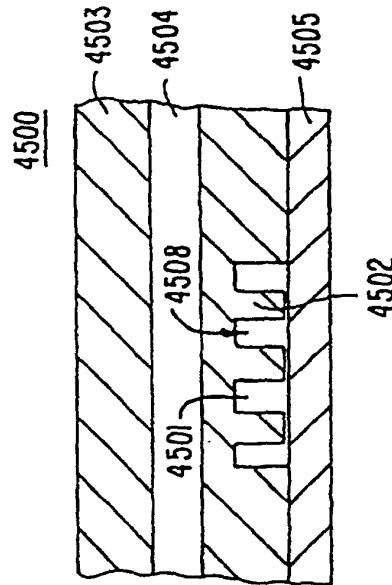

FIG. 45B.

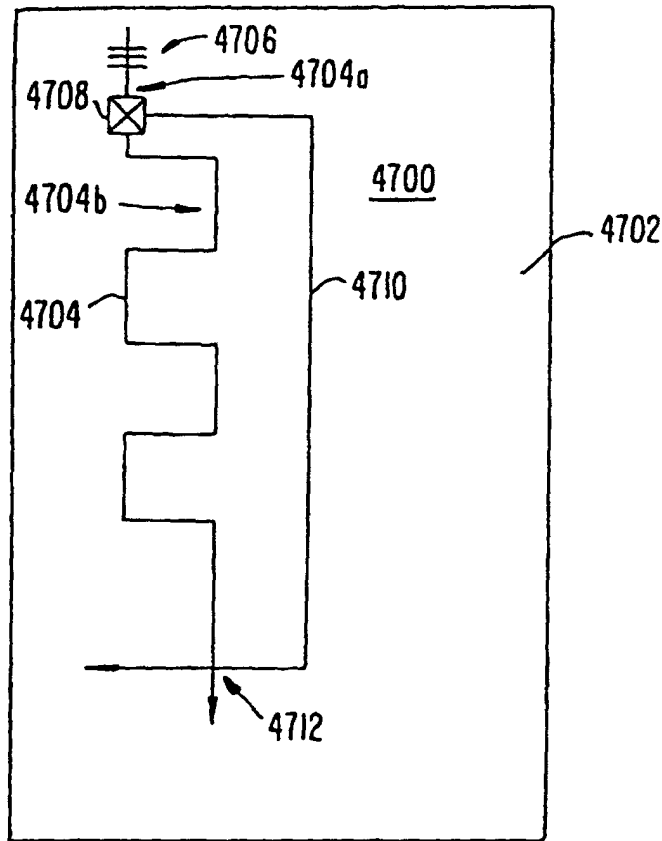

FIG. 47.

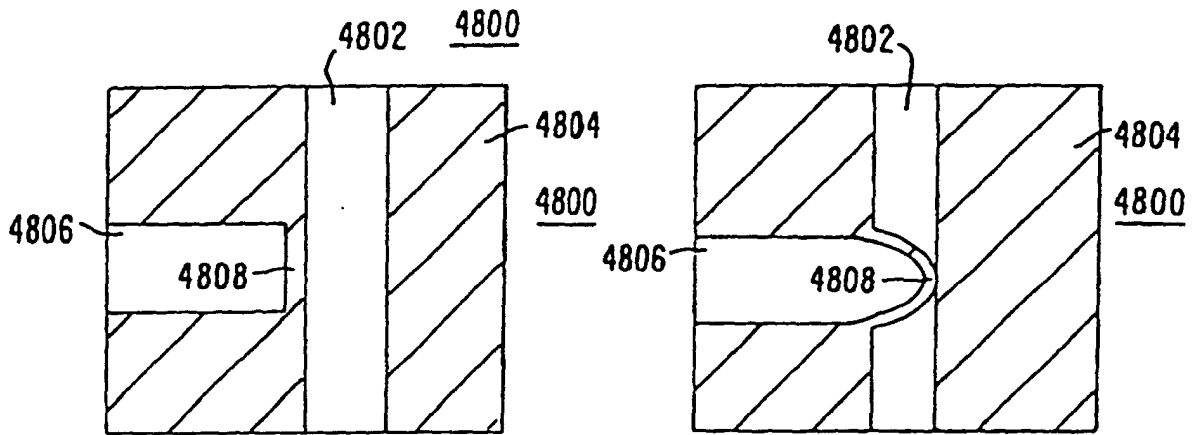

FIG. 48A.

FIG. 48B.

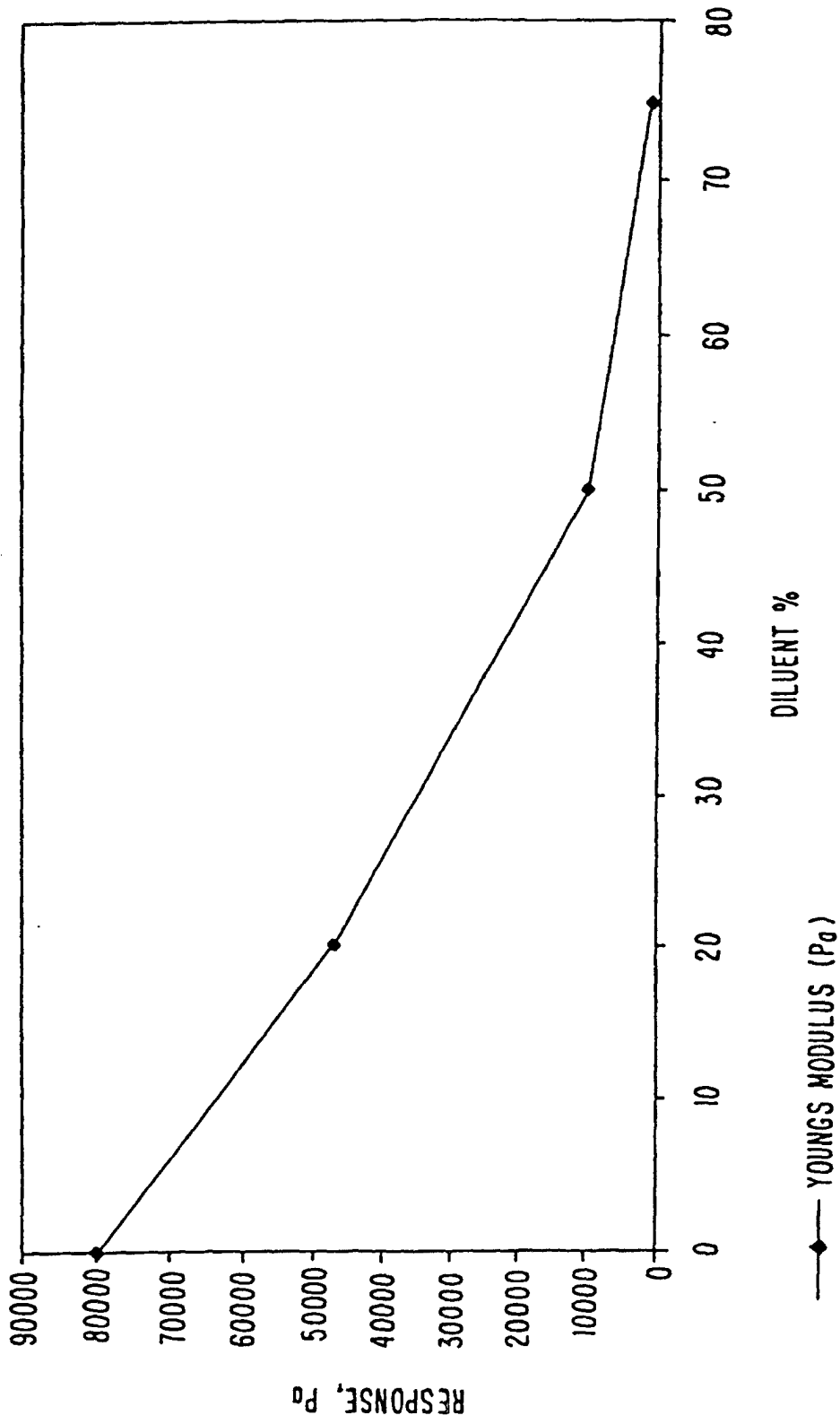

FIG. 49.