



(12) **United States Design Patent**
Norton et al.

(10) **Patent No.:** **US D935,056 S**
(45) **Date of Patent:** **** Nov. 2, 2021**

- (54) **BRIDGE PIECE**
- (71) Applicant: **Cleveland Reclaim Industries, Inc.**,
Lorain, OH (US)
- (72) Inventors: **Tom Norton**, Bay Village, OH (US);
Robert Mestdagh, Ackley, IA (US);
Dennis R Hildebrandt, Jr., North
Olmsted, OH (US); **Michael W**
Jackson, Wooster, OH (US)
- (73) Assignee: **Cleveland Reclaim Industries**, Lorain,
OH (US)
- (**) Term: **15 Years**
- (21) Appl. No.: **29/643,276**
- (22) Filed: **Apr. 6, 2018**

D314,240 S	1/1991	Scheiwiller	
5,777,266 A	7/1998	Herman	
D414,276 S	9/1999	Bruno	
D418,818 S *	1/2000	Henry	D25/160
D435,304 S	12/2000	Rainey	
6,202,565 B1	3/2001	Henry	
6,287,047 B1 *	9/2001	Dufresne	E01F 9/529 138/106
D463,041 S *	9/2002	Dice	D25/118
6,508,041 B1 *	1/2003	Boot	E04B 2/18 52/578
6,878,881 B1 *	4/2005	Henry	H02G 9/02 104/275
7,037,037 B1	5/2006	Smith	
D567,913 S *	4/2008	Norton	D23/259
8,678,704 B1 *	3/2014	Smith	E02B 3/14 405/16

(Continued)

Primary Examiner — Anhdao Doan
(74) *Attorney, Agent, or Firm* — Calfee, Halter &
Griswold LLP

Related U.S. Application Data

- (63) Continuation of application No. 29/584,435, filed on
Nov. 15, 2016, now Pat. No. Des. 815,306, which is
a continuation of application No. 29/522,823, filed on
Apr. 2, 2015, now Pat. No. Des. 772,431.

- (51) **LOC (13) Cl.** **25-01**
- (52) **U.S. Cl.**
- USPC **D25/113**

- (58) **Field of Classification Search**
- USPC D25/113–118, 199; D23/259
- CPC ... E04C 1/00; E04C 1/395; E04B 1/02; E02B
3/14; E02B 3/122; E02B 3/123; H02G
9/02; H02G 9/04; H02G 9/025
- See application file for complete search history.

- (56) **References Cited**

U.S. PATENT DOCUMENTS

D254,450 S 3/1980 Pulse
D298,464 S * 11/1988 Roote D25/117

- (57) **CLAIM**
- We claim the ornamental design for a bridge piece, as shown
and described.

DESCRIPTION

FIG. 1 is a front, left, top perspective view of a bridge piece;
FIG. 2 is a rear, left, bottom perspective view thereof;
FIG. 3 is a front elevational view thereof;
FIG. 4 is a rear elevational view thereof;
FIG. 5 is a right side elevational view thereof;
FIG. 6 is a left side elevational view thereof;
FIG. 7 is a top plan view thereof; and,
FIG. 8 is a bottom plan view thereof.
The broken lines immediately adjacent the shaded areas
represent the bounds of the claimed design, while all other
broken lines are directed to environment and are for illus-
trative purposes only; the broken lines form no part of the
claimed design.

1 Claim, 5 Drawing Sheets

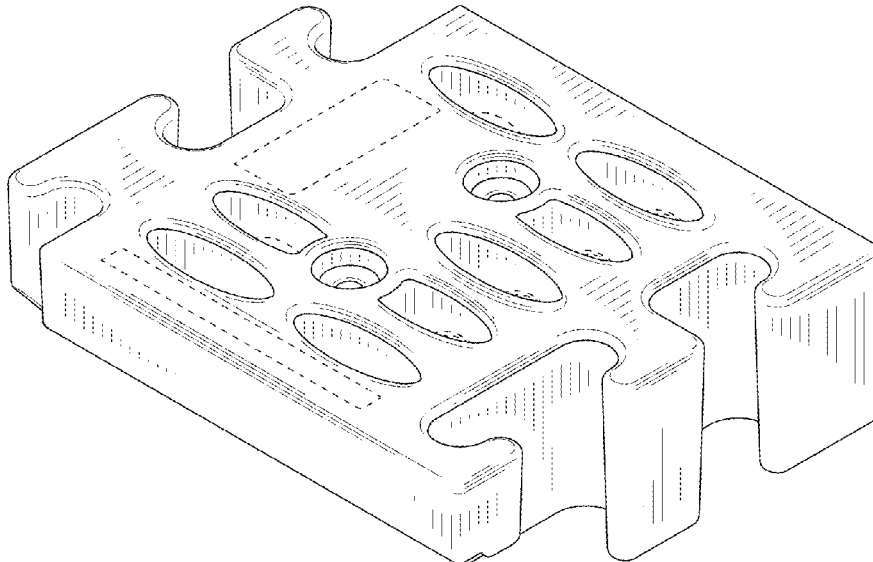

(56)

References Cited

U.S. PATENT DOCUMENTS

D725,748	S *	3/2015	Lake	D23/259
D772,431	S	11/2016	Norton	
9,512,582	B2	12/2016	Hill	
D815,306	S *	4/2018	Norton	D25/113
D844,757	S *	4/2019	Norton	D23/259
2002/0078513	A1 *	6/2002	Schouest	B60P 1/43
				14/69.5
2010/0303555	A1	12/2010	Herse	
2014/0119831	A1 *	5/2014	Hill	E02B 3/14
				405/16

* cited by examiner

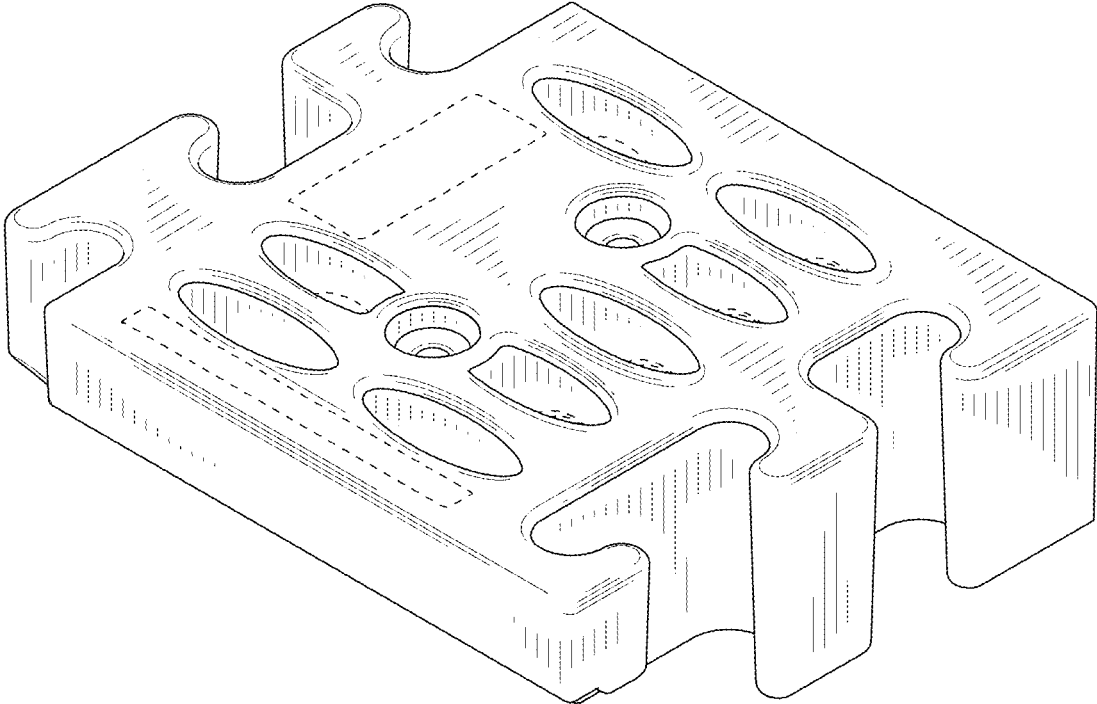

FIG. 1

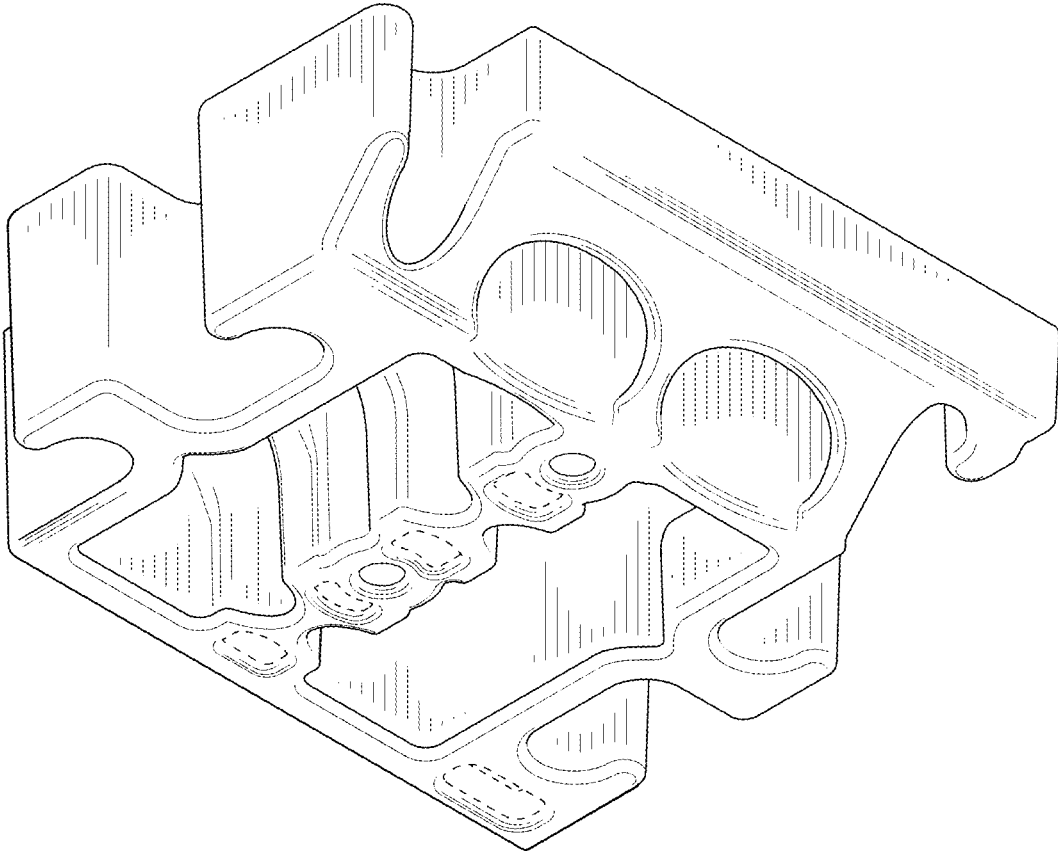

FIG. 2

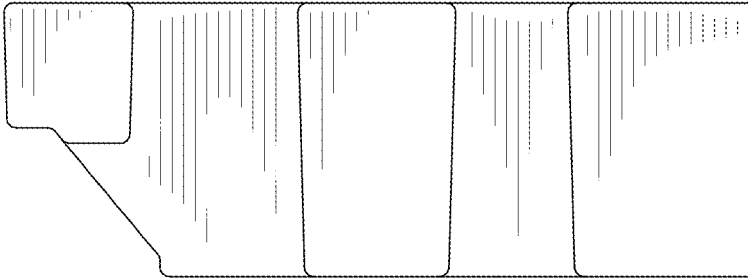

FIG. 3

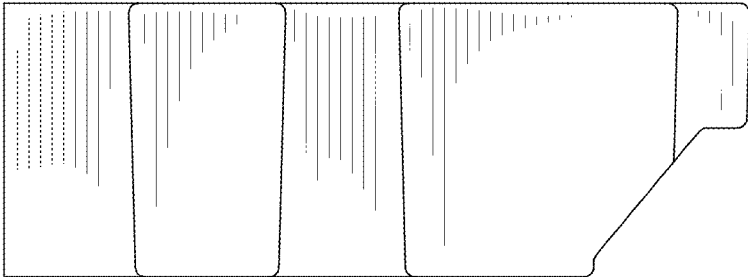

FIG. 4

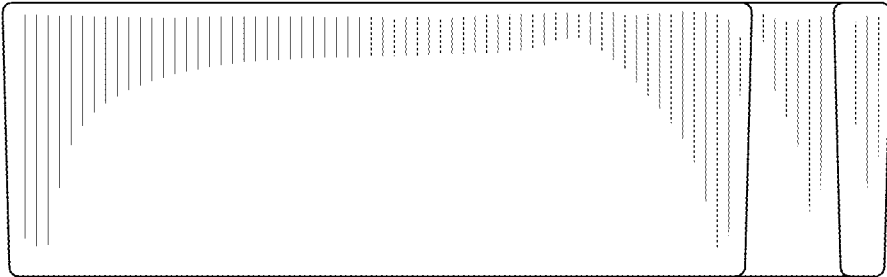

FIG. 5

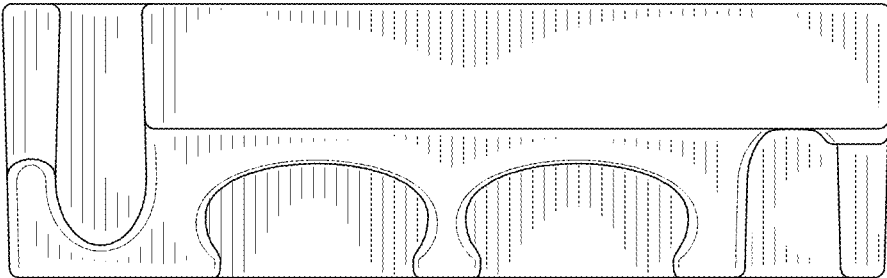

FIG. 6

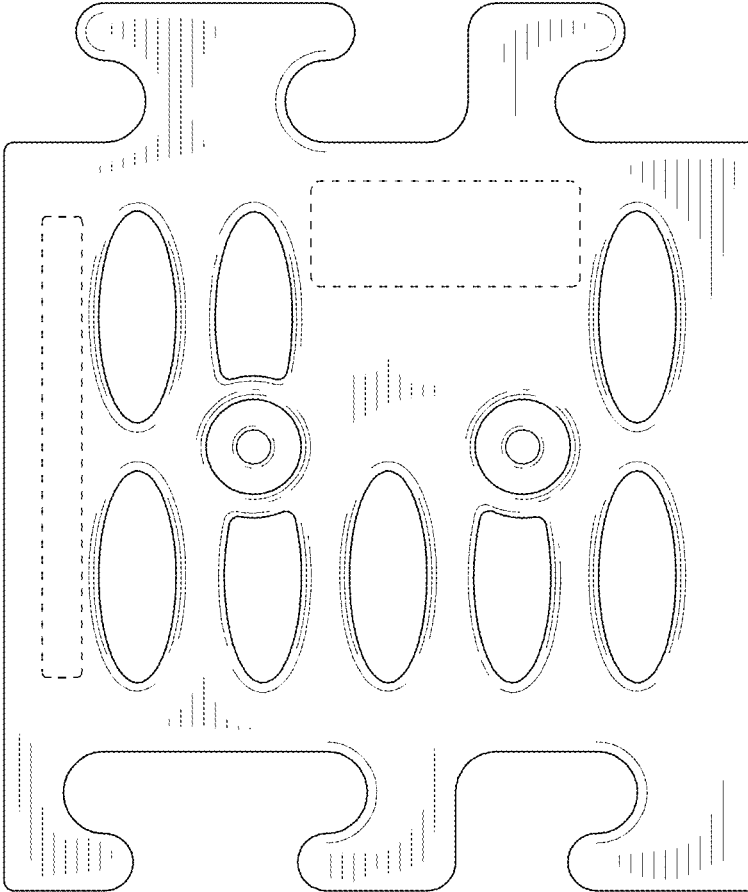

FIG. 7

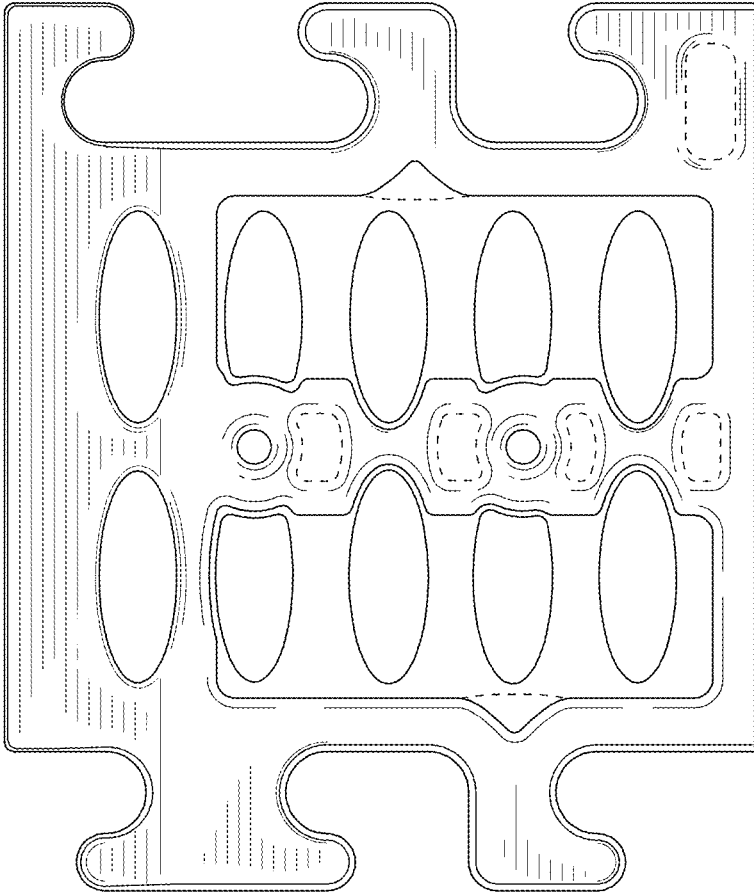

FIG. 8