

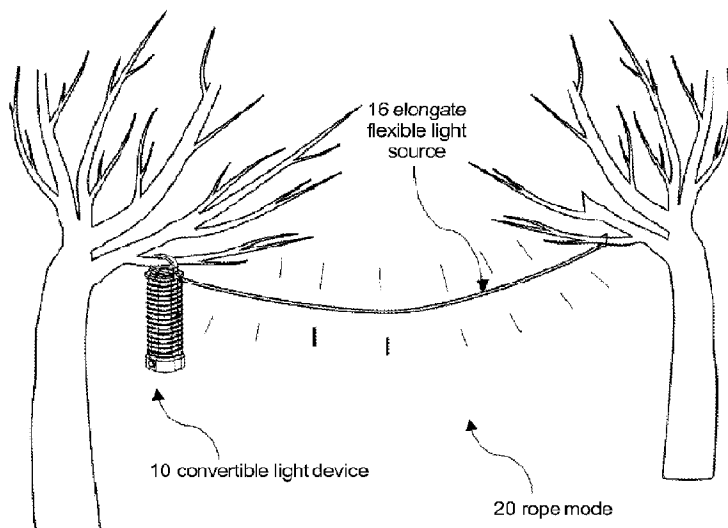

(86) Date de dépôt PCT/PCT Filing Date: 2021/06/14
 (87) Date publication PCT/PCT Publication Date: 2021/12/23
 (45) Date de délivrance/Issue Date: 2023/07/25
 (85) Entrée phase nationale/National Entry: 2022/12/09
 (86) N° demande PCT/PCT Application No.: US 2021/037284
 (87) N° publication PCT/PCT Publication No.: 2021/257483
 (30) Priorité/Priority: 2020/06/15 (US63/039,354)

(51) Cl.Int./Int.Cl. *F21S 4/26* (2016.01),
F21K 9/20 (2016.01), *F21V 17/02* (2006.01),
F21V 17/06 (2006.01), *F21V 17/16* (2006.01),
F21V 21/15 (2006.01)
 (72) Inventeurs/Inventors:
 WU, ARTHUR CHAO-CHUNG, US;
 WEIS, JARRET, US;
 BURNS, DAVID, US
 (73) Propriétaire/Owner:
 GOOD BISON, US
 (74) Agent: DICKINSON WRIGHT LLP

(54) Titre : DISPOSITIF LUMINEUX CONVERTIBLE
 (54) Title: CONVERTIBLE LIGHT DEVICE



(57) **Abrégé/Abstract:**

The disclosure includes a convertible light device comprising a housing, a battery pack coupled to the housing, and an elongate flexible light source detachably coupled to the housing and electrically coupled to the battery pack, where the elongate flexible light source comprises a plurality of LEDs. In some embodiments, the convertible light device is configured to convert between a rope mode and a lantern mode. In the rope mode, the elongate flexible light source may be configured to extend from the housing and couple to an external anchor. In the lantern mode, the elongate flexible light source may be configured to wrap around the housing.

Date Submitted: 2022/12/09

CA App. No.: 3182202

Abstract:

The disclosure includes a convertible light device comprising a housing, a battery pack coupled to the housing, and an elongate flexible light source detachably coupled to the housing and electrically coupled to the battery pack, where the elongate flexible light source comprises a plurality of LEDs. In some embodiments, the convertible light device is configured to convert between a rope mode and a lantern mode. In the rope mode, the elongate flexible light source may be configured to extend from the housing and couple to an external anchor. In the lantern mode, the elongate flexible light source may be configured to wrap around the housing.

1
2
3
4
5
6
7
8
9
10
11
12
13
14
15
16
17
18
19
20
21
22
23
24
25
26
27
28
29
30

CONVERTIBLE LIGHT DEVICE

CROSS-REFERENCE TO RELATED APPLICATIONS

This application claims priority to U.S. Patent Application No. 63/039,354; filed Jun. 15, 2020; and entitled CONVERTIBLE LIGHT DEVICE.

BACKGROUND

Field

Various embodiments disclosed herein relate to light devices. Certain embodiments relate to convertible light devices.

Description of Related Art

Portable lighting is a vital and immensely helpful element in many industries and activities, including construction, camping, boating, trade shows, photography, picnics, and even for emergency medical, search and rescue, and/or law enforcement use. Portable lighting is currently available in many forms ranging from small flashlights and lanterns to larger, freestanding lights. Some light sources, particularly ones that emit brighter light over a larger area, may require external power sources (e.g., generator) in order to operate.

Many of the previously mentioned forms of portable lighting emit light from a single concentrated area. While some of these lights may emit over a large area, the light emitted is still brightest at the light source and fades as the distance from the light source increases. String lights, such as those commonly used for holiday decorations, emit light over a greater area with more consistent light emission than the previously mentioned light forms. However, like other portable light sources, many string lights require external power sources. Some string lights are battery-powered, but these lights are generally very small and emit enough light for decoration, but not enough for practical use. As such, there is need for improved portable lighting that emits consistently bright light over a large area and does not require external power.

1
2
3
4
5
6
7
8
9
10
11
12
13
14
15
16
17
18
19
20
21
22
23
24
25
26
27
28
29
30
31

SUMMARY

The disclosure includes a convertible light device, which, in some embodiments, comprises a housing, a battery pack coupled to the housing, and an elongate flexible light source detachably coupled to the housing and electrically coupled to the battery pack, wherein the elongate flexible light source comprises a plurality of LEDs. In many embodiments, the elongate flexible light source comprises a rope light.

The elongate flexible light source may be configured to convert between a rope mode and a lantern mode, wherein in the lantern mode, the elongate flexible light source is configured to wrap around an exterior of the housing and in the rope mode, the elongate flexible light source is configured to unwrap and extend from the exterior of the housing. In some embodiments, the elongate flexible light source comprises a first end coupled to a magnetic end cap and a second end located opposite the first end and detachably coupled adjacent a base portion of the housing. When the convertible light device is in the rope mode, the first end of the elongate flexible light source may be configured to extend from the housing and may be coupled to an external anchor.

When the convertible light device is in the lantern mode, the elongate flexible light source may be configured to wrap around the exterior of the housing, such that there is at least a single layer of the elongate flexible light source wrapped around the exterior of the housing. In some embodiments, the magnetic end cap is configured to couple the first end of the elongate flexible light source to the housing adjacent a top portion of the housing. The magnetic end cap may comprise a hole configured to receive an attaching mechanism configured to couple the elongate flexible light source to the external anchor.

The battery pack may comprise a plurality of lithium-ion batteries. In some embodiments, the battery pack is configured to slideably couple to an interior portion of the housing, such that the battery pack is at least partially held within the housing. In many embodiments, the interior portion of the housing further comprises a storage compartment located above the battery pack.

The convertible light device may further comprise a lid removably coupled to a top portion of the housing, wherein the lid may be configured to provide access to the storage compartment. In some embodiments, the lid is configured to removably couple to an

1 attaching mechanism, the attaching mechanism configured to couple the elongate flexible
2 light source to an external anchor.

3 In some embodiments, the convertible light device further comprises a handle
4 coupled to a top portion of the housing, the handle configured to rotate about 180 degrees.
5 The housing may further comprise at least one charging port configured to enable charging
6 of at least one of the battery pack and an external device. In some embodiments, the
7 convertible light device further comprises a plurality of battery level indication lights and
8 a battery indication button coupled to the housing. The battery indication button may be
9 configured to illuminate at least one battery level indication light of the plurality of battery
10 level indication lights.

11 In some embodiments, the convertible light device further comprises a brightness
12 knob located on the housing, wherein the brightness knob is configured to control a
13 brightness of the light emitted by the plurality of LEDs of the elongate flexible light source.
14 The convertible light device may further comprise a power boost button located on the
15 housing, and the power boost button may be configured to amplify a light output of the
16 plurality of LEDs. In many embodiments, the convertible light device further comprises an
17 LED located on a base of the housing, the LED configured to operate as a flashlight,
18 wherein the LED is operatively coupled to a flashlight button located on the housing.

19 The convertible light device may further comprise a wrapping guide rail located on
20 an exterior of the housing, the wrapping guide rail configured to guide the elongate flexible
21 light source around an exterior of the housing. In some embodiments, the housing
22 comprises a base portion comprised of a material configured to absorb impact. The
23 elongate flexible light source may comprise a frosted material configured to diffuse the
24 light emitted by the plurality of LEDs.

25 In some embodiments, the housing comprises a top portion, a base portion, and a
26 middle portion, wherein the top portion and the base portion each define a first width and
27 the middle portion defines a second width, wherein the second width is smaller than the
28 first width.

29
30
31

1 BRIEF DESCRIPTION OF THE DRAWINGS

2 These and other features, aspects, and advantages are described below with
3 reference to the drawings, which are intended to illustrate, but not to limit, the invention.
4 In the drawings, like reference characters denote corresponding features consistently
5 throughout similar embodiments.

6 Figures 1A and 1B illustrate perspective views of a convertible light device,
7 according to some embodiments.

8 Figures 2 illustrates a perspective view of a convertible light device, according to
9 some embodiments.

10 Figure 3 illustrates a perspective view of a top portion of a convertible light device,
11 according to some embodiments.

12 Figure 4 illustrates a perspective view of a first end of an elongate flexible light
13 source coupled to an attachment mechanism, according to some embodiments.

14 Figure 5 illustrates a perspective view of a second end of an elongate flexible light
15 source, according to some embodiments.

16 Figure 6 illustrates a perspective view of a convertible light device, according to
17 some embodiments.

18 Figures 7A and 7B illustrate front views of a plurality of buttons of the convertible
19 light device, according to some embodiments.

20 Figure 8 illustrates a back view of a convertible light device, according to some
21 embodiments.

22 Figure 9 illustrates a cross-section of a convertible light device, according to some
23 embodiments.

24 Figures 10A and 10B illustrate a method of removing a lid of a convertible light
25 device, according to some embodiments.

26 Figure 11 illustrates a bottom perspective view of a convertible light device
27 including a flashlight, according to some embodiments.

28
29 DETAILED DESCRIPTION

30 Although certain embodiments and examples are disclosed below, inventive subject
31 matter extends beyond the specifically disclosed embodiments to other alternative

1 embodiments and/or uses, and to modifications and equivalents thereof. Thus, the scope of
2 the claims appended hereto is not limited by any of the particular embodiments described
3 below. For example, in any method or process disclosed herein, the acts or operations of
4 the method or process may be performed in any suitable sequence and are not necessarily
5 limited to any particular disclosed sequence. Various operations may be described as
6 multiple discrete operations in turn, in a manner that may be helpful in understanding
7 certain embodiments; however, the order of description should not be construed to imply
8 that these operations are order dependent. Additionally, the structures, systems, and/or
9 devices described herein may be embodied as integrated components or as separate
10 components.

11 For purposes of comparing various embodiments, certain aspects and advantages
12 of these embodiments are described. Not necessarily all such aspects or advantages are
13 achieved by any particular embodiment. Thus, for example, various embodiments may be
14 carried out in a manner that achieves or optimizes one advantage or group of advantages
15 as taught herein without necessarily achieving other aspects or advantages as may also be
16 taught or suggested herein.

17

18 REFERENCE NUMERALS

- 19 10 – convertible light device
20 12 – housing
21 14 – battery pack
22 16 – elongate flexible light source
23 18 – plurality of LEDs
24 20 – rope mode
25 22 – lantern mode
26 24 – exterior (of housing)
27 26 – first end (of elongate flexible light source)
28 28 – second end (of elongate flexible light source)
29 30 – magnetic end cap
30 32 – attaching mechanism
31 34 – plurality of lithium-ion batteries

- 1 36 – hole (in magnetic end cap)
- 2 38 – storage compartment
- 3 40 – lid
- 4 42 – locking knob
- 5 44 – handle
- 6 46 – battery indication button
- 7 48 – top portion (of housing)
- 8 50 – base portion (of housing)
- 9 52 – middle portion (of housing)
- 10 54 – at least one charging port
- 11 56 – power boost button
- 12 58 – brightness knob
- 13 60 – at least one battery level indication light
- 14 62 – first width
- 15 64 – second width
- 16 66 – flashlight button
- 17 68 – flashlight
- 18 70 – frosted material
- 19 72 – wrapping guide rail
- 20 74 – elongate flexible light source port
- 21 76 – elongate flexible light source connector
- 22 78 – magnet
- 23 80 – metal plate

24

25 Figure 1A illustrates the convertible light device 10 in a rope mode 20 and Figure
26 1B illustrates the convertible light device 10 in a lantern mode 22. In some embodiments,
27 the convertible light device 10 includes an elongate flexible light source 16 that is
28 configured to coil around the housing of the convertible light device 10. In the rope mode
29 20, the elongate flexible light source 16 may be configured to uncoil from the housing and
30 extend from the housing to an external anchor point, as shown in Figure 1A. Examples of
31 external anchor points include, but are not limited to, a tree, a tent, a vehicle, a fence, a

1 building, a boom on a boat, and the like. Accordingly, the convertible light device 10 may
2 be particularly useful, in both the rope mode 20 and lantern mode 22, in a variety of
3 circumstances, including: camping (e.g., inside a tent and/or to provide light to larger
4 campsite area for cooking/food prep, playing games, reading, socializing, etc.), boating
5 (e.g., yachting, cabin of a sailboat, etc.), RV use/ “glamping” (e.g., use inside or outside
6 vehicle, similar to camping), road trips, picnics, trade shows, backyards, and photography
7 (e.g., indoor studio or off-site photoshoot). In addition, the convertible light device 10 may
8 provide significant safety benefits, for example to illuminate a bicycle/bicyclist,
9 pedicab/pedicab driver, and emergency lighting for individual users/families during a
10 power outage, in addition to law enforcement and/or search and rescue for nighttime
11 operations. It should be noted that the recited uses are included as examples and intended
12 to be non-limiting.

13 In the lantern mode 22, the elongate flexible light source 16 may be configured to
14 coil around the housing 12 of the light device 10 such that the light device 10 emits light
15 from a concentrated area, as illustrated by Figure 1B. In many embodiments, the elongate
16 flexible light source 16 comprises a plurality of light sources, such as a plurality of LEDs
17 18 (shown in Figure 9), that extend substantially the entire length of the elongate flexible
18 light source 16. The elongate flexible light source 16 may be detachably coupled to the
19 housing 12 and electrically coupled to a battery pack 14, which will be discussed in greater
20 detail with reference to Figure 9. More details of the elongate flexible light source 16 will
21 be discussed later in the disclosure.

22 Figure 2 shows a front perspective view of the convertible light device 10. As
23 illustrated, in some embodiments, the light device 10 includes a housing 12, an elongate
24 flexible light source 16, a handle 44, and an attaching mechanism 32. The first end 26 of
25 the elongate flexible light source 16 may be coupled to a magnetic end cap 30, as illustrated
26 in Figure 2. In many embodiments, the magnetic end cap 30 includes a hole 36 (shown in
27 Figure 4) configured to receive the attaching mechanism 32. The attaching mechanism 32
28 may thereby be configured to couple the first end 26 of the elongate flexible light source
29 16 to an external anchor when the convertible light device 10 is in the rope mode 20. When
30 the convertible light device 10 is in the lantern mode 22, a magnet 78 of the magnetic end
31 cap 30 may be configured to couple to a metal plate 80 located on the housing 12, as

1 indicated in Figure 3, thereby coupling the elongate flexible light source 16 to the housing
2 12.

3 Figure 2 also includes a brightness knob 58 coupled to the housing 12. The
4 brightness knob 58 may be located adjacent an end of the housing 12 opposite the handle
5 44, as shown in Figure 2. In many embodiments, the brightness knob 58 is configured to
6 control a brightness of the light emitted by the plurality of LEDs 18 of the elongate flexible
7 light source 16. The brightness knob 58 may comprise a knob, switch, button (i.e., digital
8 control), slider, or the like. In some embodiments, the brightness knob 58 serves as a power
9 on/off feature, where turning the brightness knob 58 to at least a minimum level comprises
10 turning on the convertible light device 10. The brightness knob 58 may include any number
11 of brightness settings, ranging from very dim light emission to full light emission. In some
12 embodiments, the brightness knob 58 is configured to provide finely-tuned control over a
13 large range of brightness levels, such that a user is able to adjust the brightness to a precise
14 level. The brightness knob 58 may comprise a number of pre-set levels rather than precise
15 control. In some embodiments, the brightness knob 58 is configured to facilitate a “ramp
16 up” sequence of illuminating the elongate flexible light source 16, such that a portion of
17 the elongate flexible light source 16 turns on prior to another portion of the elongate
18 flexible light source 16.

19 Figure 3 shows a perspective view of a top portion 48 of the housing 12. As
20 previously mentioned, the convertible light device 10 may include a metal plate 80 located
21 on the housing 12 and a magnet 78 located on the magnetic end cap 30 of the elongate
22 flexible light source 16, wherein the magnet 78 is configured to couple to the metal plate
23 80, thereby coupling the elongate flexible light source 16 to the housing 12 in the lantern
24 mode 22. The housing 12 may include a plurality of metal plates 80. In some embodiments,
25 the housing 12 comprises a metal material configured to couple to the magnetic end cap
26 30. The magnetic end cap 30 may comprise a non-magnetic end cap, and may be configured
27 to couple to the housing 12 via a friction fit, hook-and-loop fastener, or any other suitable
28 means.

29 Also illustrated in Figure 3 are the handle 44, lid 40, and attaching mechanism 32.
30 In many embodiments, the lid 40 is configured to receive the attaching mechanism 32 when
31 the convertible light device 10 is in lantern mode 22 and the attaching mechanism 32 is not

1 coupled to the magnetic end cap 30. The removable coupling between the attaching
2 mechanism 32 and the lid 40 will be discussed further with reference to Figures 10A and
3 10B. In many embodiments, the handle 44 is configured to rotate about 180 degrees. Stated
4 another way, the handle 44 may be configured to pivot or “flip” such that it is able to rest
5 on top of either side of the lid 40. The handle 44 may be configured to “lock” or remain in
6 an upright position. In some embodiments, the handle 44 is comprised of a rigid, inflexible
7 material, such as metal or hard plastic. The handle 44 may be comprised of a soft, flexible
8 material, such as rubber, leather, or another fabric. In some embodiments, the handle 44 is
9 removably coupled to the convertible light device 10 such that a user may “switch out”
10 different types of handle 44, depending on desired utility or aesthetic.

11 In some embodiments, the handle 44 is configured to open in a manner similar to a
12 carabiner to enable the handle 44 to hook onto an external anchor so that the housing 12 of
13 the convertible light device 10 can be suspended, such as from a tree, as illustrated in Figure
14 1A. The handle 44 may also be configured to at least partially detach from the housing 12
15 to facilitate coupling the light device 10 to an external anchor. In some embodiments, the
16 handle 44 is not configured to open or partially detach, and instead the external anchor is
17 threaded through the opening between the handle 44 and the housing 12. The handle 44
18 may comprise any suitable type of clip, clasp, tie, hook, loop, magnet, and the like.

19 Figure 4 shows an enlarged view of the attaching mechanism 32 coupled to the first
20 end 26 of the elongate flexible light source 16 via the hole 36 in the magnetic end cap 30.
21 As previously discussed, in many embodiments, the attaching mechanism 32 is configured
22 to detachably couple to the magnetic end cap 30 and, when not coupled to the magnetic
23 end cap 30, the attaching mechanism 32 is configured to couple to the lid 40. Though
24 illustrated as a carabiner-style mechanism, similar to the handle 44, the attaching
25 mechanism 32 may comprise any suitable type of attaching mechanism, including, but not
26 limited to, other types of clips, clasps, ties, hooks, loops, magnets, and the like. In addition,
27 the attaching mechanism 32 may comprise any suitable shape, including, but not limited
28 to, rectangle, circle, triangle, oval, teardrop, diamond, trapezoid, and heart. In some
29 embodiments, the attaching mechanism 32 defines a substantially similar shape as the lid
30 40. The attaching mechanism 32 may also define a size suitable to couple to the lid 40.

1 Rather than a magnetic end cap 30, the first end 26 of the elongate flexible light
2 source 16 may comprise a clip or other type of mechanical connector similar to the
3 attaching mechanism 32. In some embodiments, the first end 26 is fixedly coupled to a
4 mechanical connector similar to the attaching mechanism 32. The first end 26 may
5 comprise an electrical connector configured to couple to a second elongate flexible light
6 source 16. Accordingly, in some embodiments, the convertible light device 10 comprises
7 a plurality of elongate flexible light sources 16. Using a plurality of elongate flexible light
8 sources 16 may allow a user to illuminate a larger area without requiring more than one
9 housing 12 and battery pack 14. In some embodiments, the electrical connection between
10 multiple elongate flexible light sources 16 allows a single brightness knob 58 to control the
11 brightness of multiple elongate flexible light sources 16, either independently or as a group.

12 Figure 5 illustrates a perspective view of a base portion 50 of the housing 12. It
13 should be noted that the base portion 50 shown in Figure 5 may be considered a “back”
14 side of the housing 12, while the side of the housing 12 shown in Figure 2 featuring the
15 brightness knob 58 may be considered a “front” side. Of course, each user of the
16 convertible light device 10 may consider any side “front” or “back” without any impact on
17 the operation of the device 10.

18 As shown in Figure 5, in some embodiments, the elongate flexible light source 16
19 comprises a second end 28 configured to detachably couple adjacent the base portion 50 of
20 the housing 12. The second end 28 may comprise an elongate flexible light source
21 connector 76, while the housing 12 may comprise an elongate flexible light source port 74
22 configured to receive the elongate flexible light source connector 76. In many
23 embodiments, the elongate flexible light source connector 76 is configured to mechanically
24 couple to the housing 12 and electrically couple to the battery pack 14, thus providing
25 power to the elongate flexible light source 16. At least one of the elongate flexible light
26 source port 74 and the elongate flexible light source connector 76 may be magnetic. In
27 some embodiments, the elongate flexible light source connector 76 is configured to couple
28 to the elongate flexible light source port 74 via a friction fit, similar to a typical electrical
29 connection (e.g., charging cable and an electronic device, plug and an electrical socket,
30 etc.). Alternatively, the second end 28 of the elongate flexible light source 16 may be
31 configured to fixedly couple to the housing 12, and the convertible light device 10 may not

1 include the elongate flexible light source connector 76 or the elongate flexible light source
2 port 74 as shown in Figure 5.

3 In some embodiments, the elongate flexible light source 16 is configured to
4 illuminate even when detached from the elongate flexible light source port 74 of the
5 housing 12. Accordingly, the elongate flexible light source 16 may be able to “hold” or
6 maintain a charge and emit light even when disconnected from the battery pack 14 within
7 the convertible light device 10. When detached, a user may be able to use the elongate
8 flexible light source 16 in additional ways, such as wearing the elongate flexible light
9 source 16, wrapping it around a bicycle or scooter, wrapping it around a pet (e.g., as a
10 harness for a dog when walking at night or early in the morning), and/or any number of
11 other ways.

12 In addition, the ability to detach the elongate flexible light source 16 from the
13 housing 12 may increase the portability of the convertible light device 10. For example, a
14 user may desire to use the flashlight 68 (shown in Figure 6) located on the base portion 50
15 of the housing 12 to walk a distance away from the current location of the device 10. If the
16 device 10 were in the rope mode 20, it would be a hassle to wind up the elongate flexible
17 light source 16 prior to walking away with the device 10. Instead, the user may detach the
18 elongate flexible light source 16 at the second end 28 and simply leave the elongate flexible
19 light source 16 behind as the user walks away with the device 10 and uses the flashlight
20 68, such as to walk to a restroom, into a tent, etc. As such, the convertible light device 10
21 may be configured to provide light to two different locations simultaneously, as the
22 elongate flexible light source 16 may continue emitting light while the user moves away
23 with the flashlight 68 of the housing 12.

24 At least some portion of the second end 28 may not include the plurality of LEDs
25 18 that make up the elongate flexible light source 16. As such, the second end 28 may
26 comprise some distance of the elongate flexible light source 16 that comprises a plain cable
27 without any LEDs. In some embodiments, the distance is a few inches.

28 Referring now to Figure 6, another perspective view of the convertible light device
29 10 is illustrated, including a flashlight 68 located on the base portion 50 of the housing 12.
30 The flashlight 68 will be discussed in greater detail later in the disclosure, in particular with
31 reference to Figure 11. Similar to Figure 5, Figure 6 may be considered to show a “back”

1 side of the housing 12, opposite the “front” side including the brightness knob 58. As
2 shown in Figure 6, in some embodiments, the base portion 50 of the housing 12 includes a
3 plurality of buttons located below the second end 28 of the elongate flexible light source
4 16. In addition to the plurality of buttons, the base portion 50 may include at least one
5 charging port 54 and at least one battery level indication light 60. It should be noted that at
6 least some of these components may be included on the top portion 48 of the housing 12,
7 along with the handle 44.

8 In many embodiments, the at least one charging port 54 is configured to enable
9 charging of at least one of the battery pack 14 (shown in Figure 9) and at least one external
10 device, such as a mobile phone, tablet, laptop, speaker, or the like. The at least one charging
11 port 54 may be configured to provide “quick charging” to at least one of the battery pack
12 14 and the external device. In some embodiments, the at least one charging port 54 is
13 configured to charge the battery pack 14 and/or at least one external device while the
14 convertible light device 10 is in use (i.e., while at least one of the flashlight 68 and elongate
15 flexible light source 16 are illuminated). Details of the battery pack, including the
16 rechargeable nature of the batteries, will be discussed with reference to Figure 9. The at
17 least one charging port 54 may comprise a USB port, a USB-C port, a barrel-plug, or any
18 other suitable connection type. It should be noted that each port of the at least one charging
19 port 54 may comprise the same type of port connection, or may comprise different types
20 of port connections. In some embodiments, one port is an input port, and one port is an
21 output port. The at least one charging port 54 may comprise a single input/output port. The
22 light device 10 may also be configured to charge wirelessly via a charging dock, rather
23 than a charging port.

24 Among the plurality of buttons shown in Figure 6 are a power boost button 56 and
25 a flashlight button 66. In many embodiments, the flashlight button 66 is operatively
26 coupled to the flashlight 68 located on the bottom of the housing 12, and is configured to
27 power on/off the flashlight 68. It should be noted that any and/or all of the plurality of
28 buttons (battery indication button 46, power boost button 56, flashlight button 66) may
29 comprise dials or other selection mechanisms, rather than buttons. In addition, the plurality
30 of buttons, the at least one charging port 54, and the at least one battery level indication
31 light 60 may be arranged in a different layout than shown in the Figures.

1 In many embodiments, the power boost button 56 is configured to amplify a light
2 output of the plurality of LEDs 18 of the elongate flexible light source 16. Stated another
3 way, the power boost button 56 may serve as a way to increase the light output of the
4 elongate flexible light source 16 without using the brightness knob 58. In some
5 embodiments, the power boost button 56 is configured to enable a maximum emission of
6 light to a level beyond what can be reached with the brightness knob 58. Rather than a
7 power boost button 56, the brightness knob 58 may be configured to turn past a certain
8 point (i.e., the highest “normal” level) to reach the same level of light emission achieved
9 by the power boost button 56. The power boost button 56 may be configured to enable an
10 increased level of light emission for an extended period of time. In some embodiments, the
11 power boost button 56 is configured to enable an increased level of light emission for a
12 shorter period of time (e.g., 5 minutes, 2 minutes, 90 seconds, 60 seconds, 30 seconds, 10
13 seconds, etc.) in order to preserve battery life. The power boost button 56 may be
14 operatively coupled to at least one of the elongate flexible light source 16 and the flashlight
15 68.

16 Figure 6 also indicates that, in some embodiments, the convertible light device 10
17 includes a battery indication button 46 and at least one battery level indication light 60
18 coupled to at least one of the housing 12 and the battery pack 14. The battery indication
19 button 46 and at least one battery level indication light 60 may be located on a top portion
20 48, base portion 50 (as shown), or anywhere else on the housing 12, either in the same or
21 different locations. In many embodiments, when pressed, the battery indication button 46
22 is configured to illuminate the at least one battery level indication light 60 according to a
23 power level of the battery pack 14. For example, as shown in Figure 7A, a full charge of
24 the battery pack 14 may be configured to illuminate all of the lights of the at least one
25 battery level indication light 60. As indicated in Figure 7B, a low charge of the battery pack
26 14 may be configured to illuminate fewer of the at least one battery level indication light
27 60, for example, two lights.

28 In some embodiments, as shown in Figures 7A and 7B, the at least one battery level
29 indication light 60 comprises five lights. Each light may represent 20% of battery life, such
30 that Figure 7A indicates 100% battery life and Figure 7B indicates 40% battery life. Of
31 course, the at least one battery level indication light 60 may comprise any number of lights.

1 In some embodiments, while the convertible light device 10 is charging, the at least one
2 battery level indication light 60 is configured to illuminate to indicate progress of the
3 charging cycle. The at least one battery level indication light 60 may illuminate
4 continuously or non-continuously (i.e., “blinking”). In many embodiments, the at least one
5 battery level indication light 60 comprises LED light(s). The at least one battery level
6 indication light 60 may comprise another type of light. Rather than at least one battery level
7 indication light 60, the convertible light device 10 may be configured to indicate battery
8 life another way(s). For example, the elongate flexible light source 16 may be configured
9 to illuminate in a distinct color and/or pattern to indicate battery level. In addition, a user
10 may be able to see battery life on a mobile application communicatively coupled to the
11 convertible light device 10.

12 Figure 8 shows the convertible light device 10, including the top portion 48, middle
13 portion 52, and base portion 50 of the housing 12. As previously discussed, in many
14 embodiments the top portion 48 includes the handle 44 and the base portion 50 includes
15 the brightness knob 58, at least one charging port 54, flashlight button 66, power boost
16 button 56, battery indication button 46, and at least one battery level indication light 60, as
17 shown in Figures 2 and 6. Figure 8 also illustrates the middle portion 52, which, in many
18 embodiments, is where the elongate flexible light source 16 winds around the housing 12.
19 It should be noted that Figure 8 is shown without much of the elongate flexible light source
20 16 in order to better illustrate the features of the housing 12, particularly the middle portion
21 52.

22 Figure 8 demonstrates that, in some embodiments, the exterior 24 of the middle
23 portion 52 of the housing 12 comprises a wrapping guide rail 72. The wrapping guide rail
24 72 may be configured to receive the elongate flexible light source 16, and may enable
25 winding of the elongate flexible light source 16 in an even and orderly manner. In some
26 embodiments, winding the elongate flexible light source 16 in an even manner facilitates
27 substantially even distribution of the plurality of LEDs 18 when the convertible light device
28 10 is in the lantern mode 22. The wrapping guide rail 72 may be configured to receive at
29 least a single layer of the elongate flexible light source 16, such that in the lantern mode 22
30 there may be at least a single layer of the elongate flexible light source 16 wrapped around
31 the exterior 24 of the housing 12. In some embodiments, the wrapping guide rail 72 is

1 configured to receive multiple layers of the elongate flexible light source 16. Some
2 embodiments of the convertible light device 10 do not include the wrapping guide rail 72,
3 and instead include a smooth, even surface extending the length of the middle portion 52
4 of the housing 12. The convertible light device 10 may include the ability to automatically
5 wind the elongate flexible light source 16 around the housing 12, either with or without the
6 wrapping guide rail 72. For example, in some embodiments, the light device 10 includes a
7 winding mechanism configured to facilitate winding of the elongate flexible light source
8 16 around the exterior 24 of the housing 12. The winding mechanism may be operated
9 mechanically or electrically, and may include any type of winding mechanism (e.g., crank,
10 gear, and the like). The winding mechanism may be detachably or fixedly coupled
11 anywhere on the light device 10.

12 Figure 8 also illustrates the first width 62 of the base portion 50 and the second
13 width 64 of the middle portion 52. It should be noted that, in many embodiments, the first
14 width 62 also represents the width of the top portion 48. As shown in Figure 8, the first
15 width 62 may be larger than the second width 64. In some embodiments, the first width 62
16 is smaller than the second width 64. The first width 62 and second width 64 may also define
17 substantially the same width. In many embodiments, when the elongate flexible light
18 source 16 is wrapped around the middle portion 52, the width of the middle portion 52 is
19 still less than the first width 62 of the base portion 50. When the elongate flexible light
20 source 16 is wrapped around the middle portion 52, the width of the middle portion 52 may
21 be substantially equal to the first width 62 of the base portion 50.

22 Figure 9 shows a cross-section view of the convertible light device 10. The cross-
23 section includes the interior of the housing 12, which, in many embodiments, is configured
24 to receive the battery pack 14. The housing 12 may be configured to slideably receive the
25 battery pack 14, such that the battery pack 14 is at least partially held within the housing
26 12. The housing 12 may be configured to receive the battery pack 14 in any other suitable
27 manner. In some embodiments, the battery pack 14 is fixedly coupled to the housing 12,
28 and comprises a permanent battery pack 14. The battery pack 14 may be removably
29 coupled to the housing 12. In many embodiments, as illustrated in Figure 9, the battery
30 pack 14 defines a height less than a height of the housing 12, such that there is space within
31 the housing 12 above the battery pack 14. This space may define a storage compartment

1 38, as will be discussed further with reference to Figures 10A and 10B. The battery pack
2 14 may define a height and/or width greater or smaller than illustrated in Figure 9.

3 In some embodiments, the battery pack 14 comprises a plurality of lithium-ion
4 batteries 34. The plurality of lithium-ion batteries 34 may comprise six lithium-ion
5 batteries. The plurality of lithium-ion batteries 34 may comprise any other number of
6 batteries. In some embodiments, the battery pack 14 comprises a different type of battery
7 than lithium-ion battery. The batteries in the battery pack 14 may comprise rechargeable
8 batteries. The batteries in the battery pack 14 may comprise any suitable type of
9 rechargeable batteries. As previously discussed, in many embodiments, the battery pack 14
10 is configured to charge via the at least one charging port 54. The battery pack 14 may be
11 configured to charge via a solar panel, kinetic energy (e.g., a hand crank), or any number
12 of other suitable methods.

13 In some embodiments, the batteries are configured to illuminate the elongate
14 flexible light source 16 for a first amount of time on a full charge and at full brightness.
15 The elongate flexible light source 16 may remain illuminated for longer than the first
16 amount of time at a lower brightness level. The first amount of time may be a few hours.
17 In some embodiments, the battery pack 14 comprises a plurality of battery packs. The
18 battery pack 14 may also include a battery control board.

19 Figure 9 also illustrates the plurality of LEDs 18 that make up the elongate flexible
20 light source 16. The elongate flexible light source 16 may be thought of as a “rope light,”
21 and the plurality of LEDs 18 may be visible from either side of the “rope” (the elongate
22 flexible light source 16). The plurality of LEDs 18 may be visible from only one side of
23 the “rope.” In some embodiments, the elongate flexible light source 16 comprises a frosted
24 material 70 configured to diffuse the light emitted by the plurality of LEDs 18. The
25 convertible light device 10 may include a sheath configured to fit over (e.g., similar to a
26 sleeve) the elongate flexible light source 16, wherein the sheath may comprise a frosted
27 material 70 to diffuse light. In some embodiments, the sheath comprises a hard cover
28 configured to slideably receive the elongate flexible light source 16. The sheath may
29 protect the elongate flexible light source 16 while also diffusing light emitted by the
30 plurality of LEDs 18.

1 In some embodiments, the plurality of LEDs 18 extends substantially the entire
2 length of the elongate flexible light source 16. The plurality of LEDs 18 may extend less
3 than substantially the entire length of the elongate flexible light source 16. In some
4 embodiments, the plurality of LEDs 18 comprises a light source other than LEDs. The
5 plurality of LEDs 18 may comprise LEDs of different colors/configured to emit different
6 colors (i.e., RGB LEDs). The convertible light device 10 may be configured to operate in
7 different “modes,” where each mode illuminates the plurality of LEDs in a different
8 pattern, color, brightness, etc. For example, a “party mode” may include flashing/strobing
9 the LEDs while a “normal mode” includes steady, even illumination of the LEDs. The
10 brightness knob 58 may be configured to control and select the different modes of the
11 elongate flexible light source 16. In some embodiments, the light device 10 includes at
12 least one of Wi-Fi, Bluetooth, and cellular connectivity. This connectivity may be
13 integrated into the different modes of the light device 10; for example, “party mode” may
14 sync with music playing from a device connected (wirelessly or wired) to the light device
15 10 such that the LEDs 18 flash on beat with the music. As previously mentioned, the
16 convertible light device 10 may be communicatively coupled to a mobile application on a
17 computing device, such as a smartphone or tablet. The mobile application may enable a
18 user to program different “modes” and control the mode selection.

19 Figure 9 also shows that, in some embodiments, the convertible light device 10
20 defines a shape that is generally rectangular. A generally rectangular shape may prevent
21 the light device 10 from rolling when placed on its side, such as on a table or ground
22 surface. Instead, the convertible light device 10 may define a shape that is generally
23 circular. The convertible light device 10 may define a shape that is generally triangular,
24 generally ovoid, or any other suitable shape.

25 In many embodiments, the convertible light device 10 further comprises a lid 40
26 removably coupled to the top portion 48 of the housing 12. Figures 10A and 10B illustrate
27 a method of removing the lid 40 to gain access to the storage compartment 38, shown in
28 Figure 9. In some embodiments, as shown in Figure 10A, the lid 40 comprises a locking
29 knob 42 configured to lock and unlock the lid 40. As mentioned with reference to Figure
30 3, the attaching mechanism 32 may be configured to couple to the lid 40 when the attaching
31 mechanism 32 is not coupled to the elongate flexible light source 16. The attaching

1 mechanism 32 may be configured to detachably couple to the lid 40 via a friction fit,
2 magnet(s), or any suitable coupling mechanism.

3 A method of removing the lid 40 begins with the attaching mechanism 32 coupled
4 to the lid 40 and the locking knob 42 in the locked position, as indicated in step 1002 of
5 Figure 10A. From that point, a user may remove the attaching mechanism 32 from the lid
6 40 (at step 1004). As shown in Figure 10B, the user may then turn the locking knob 42 to
7 the unlocked position (at step 1006), and remove the lid 40 from the housing 12, thereby
8 exposing the storage compartment 38 (at step 1008). In many embodiments, the storage
9 compartment 38 is at least one of water resistant and waterproof. The storage compartment
10 38 may be sized to hold any number of items, including, but not limited to, key(s), a small
11 wallet, loose cash and/or credit card(s), a multi-tool, jewelry, small food items, and the
12 like. In some embodiments, the storage compartment 38 measures about 67mm x 67mm x
13 74mm. The storage compartment 38 may be larger than the listed dimensions. In some
14 embodiments, the storage compartment is smaller than the listed dimensions.

15 Turning now to Figure 11, a bottom perspective view of the convertible light device
16 10 is shown, including the flashlight 68 coupled to the base portion 50 of the housing 12.
17 As previously discussed, the flashlight 68 may be operatively coupled to the flashlight
18 button 66. In some embodiments, the flashlight 68 is instead turned on/off by depressing
19 the lens. The flashlight 68 may comprise a single LED configured to emit light in a singular
20 “beam” or direction. The flashlight 68 may also be configured to emit light in all directions,
21 and as such, “light up” at least the base portion 50 of the housing 12. The flashlight 68 may
22 also “light up” more of the housing 12 than just the base portion 50. The flashlight 68 may
23 comprise a single-color LED, an RGB LED, or any other suitable type of light source.
24 Similar to the elongate flexible light source 16, the flashlight 68 may comprise a
25 programmable light capable of emitting light in different “modes” comprising different
26 colors, patterns, sequences, etc. The flashlight button 66 may be configured to select at
27 least one mode of the flashlight 68. The flashlight 68 may be communicatively coupled to
28 a mobile application configured to program and control light emission from the flashlight
29 68.

30 In some embodiments, the flashlight 68 is located within the base portion 50 of the
31 housing 12. The flashlight 68 may be located at least partially within the base portion 50

1 of the housing 12. The flashlight 68 may be located on a base of the battery pack 14. In
2 addition to and/or instead of the flashlight button 66, the flashlight 68 may be controlled
3 via the brightness knob 58, and may also be operatively coupled to the power boost button
4 56. The convertible light device 10 may comprise more than one brightness knob 58, where
5 one brightness knob 58 controls the elongate flexible light source 16 and one brightness
6 knob 58 controls the flashlight 68. Similarly, the light device 10 may comprise more than
7 one power boost button 56. The convertible light device 10 may be configured such that
8 both the flashlight 68 and the elongate flexible light source 16 may be illuminated at the
9 same time.

10 In some embodiments, the base portion 50 of the housing 12 comprises a protective
11 material configured to absorb impact. For example, the base portion 50 may comprise a
12 border, ring, pad, or the like comprised of silicone, rubber, or a similar material to prevent
13 damage to the convertible light device 10 if the device 10 is dropped, knocked over, etc.
14 Substantially an entire portion of the base portion 50 of the housing 12 may comprise the
15 protective material. The protective material may be located on only certain areas of the
16 base portion 50, such as around a perimeter of the flashlight 68 and on the corners. Other
17 parts of the housing 12, in addition to or in place of the base portion 50, may comprise the
18 protective material.

19 The light device 10 may also include a cover configured to fit over at least a portion
20 of the housing 12. For example, in some embodiments, the cover is configured to fit over
21 a middle portion 52 of the housing 12 such that the cover substantially encloses the elongate
22 flexible light source 16 when the light device 10 is in the lantern mode 22. The cover may
23 comprise a material, such as a frosted material, such that the cover diffuses the light emitted
24 by the elongate flexible light source 16. The cover may be slideably coupled to the housing
25 12, and may be configured to slide toward the base of the housing 12. In some
26 embodiments, the cover serves as a stand for the light device 10 when the cover slides
27 toward the base of the housing 12. The cover may be configured to act as the winding
28 mechanism, and thereby may be configured to facilitate coiling the elongate flexible light
29 source 16 around the housing 12. The cover may be detachably coupled to the light device
30 10. In some embodiments, the cover is fixedly coupled to the housing 12.

1 The different elements of the light device 10 may comprise any number of suitable
2 materials and/or combinations of materials. For example, the housing 12 may comprise
3 polymer plastic (e.g., ABS plastic), metallic, rubber, or a combination of materials. The
4 handle 44 and attaching mechanism 32 may also comprise metallic, plastic, or combination
5 materials. The elongate flexible light source 16 may comprise the plurality of LEDs 18
6 inside flexible plastic tubing. In some embodiments, the plastic tubing is clear. The plastic
7 tubing may comprise a frosted material 70 to provide light diffusion. As previously
8 mentioned, the cover may also comprise a frosted material, such as plastic, to provide light
9 diffusion. In some embodiments, the LEDs of the plurality of LEDs 18 emit light at about
10 1000W. Any of the materials used to comprise any of the elements of the light device 10
11 may comprise substantially waterproof materials. The materials may also be substantially
12 “tough” and resistant to breaking, wear-and-tear, etc., even after being dropped, knocked
13 over, and the like.

14 In some embodiments, the convertible light device 10 comprises a single battery
15 pack 14 and a single “rope” of the elongate flexible light source 16. The rope may measure
16 about 10 feet in length. In some embodiments, the rope measures more than 10 feet in
17 length. The rope may also be fewer than ten feet in length. Another embodiment of the
18 convertible light device 10 may comprise two battery packs 14 and the elongate flexible
19 light source 16 may comprise two or more ropes. The flexible light source 16 may comprise
20 a single rope, but the single rope may be longer than the single rope of the single battery
21 pack 14 embodiments. A light device 10 including two battery packs 14 may comprise a
22 housing 12 that is at least one of wider and longer than the housing 12 of a light device 10
23 including a single battery pack 14.

24 In addition to the attaching mechanism 32 and handle 44, the convertible light
25 device 10 may be configured for additional mounting and/or hanging options. For example,
26 a base portion 50 of the housing 12 may comprise a magnetic material in order to enable
27 the housing 12 to magnetically couple to a metal surface (e.g., to the side of a camper, RV,
28 passenger vehicle, etc.). The convertible light device 10 may also be configured to couple
29 to a stand when hanging the device 10 is not possible. For example, the device 10 may
30 comprise a connector and/or mount suitable for coupling to a tri-pod typically used for a
31 camera. The convertible light device 10 may be configured to couple to a more portable

1 and/or wearable type of mount, similar to a camera accessory commonly used to record a
2 user or the user's point of view during physical activity (e.g., mountain biking, skiing,
3 snowboarding, surfing, running, etc.).
4

5 INTERPRETATION

6 None of the steps described herein is essential or indispensable. Any of the steps
7 can be adjusted or modified. Other or additional steps can be used. Any portion of any of
8 the steps, processes, structures, and/or devices disclosed or illustrated in one embodiment,
9 flowchart, or example in this specification can be combined or used with or instead of any
10 other portion of any of the steps, processes, structures, and/or devices disclosed or
11 illustrated in a different embodiment, flowchart, or example. The embodiments and
12 examples provided herein are not intended to be discrete and separate from each other.

13 The section headings and subheadings provided herein are nonlimiting. The section
14 headings and subheadings do not represent or limit the full scope of the embodiments
15 described in the sections to which the headings and subheadings pertain. For example, a
16 section titled "Topic 1" may include embodiments that do not pertain to Topic 1 and
17 embodiments described in other sections may apply to and be combined with embodiments
18 described within the "Topic 1" section.

19 Some of the devices, systems, embodiments, and processes use computers. Each of
20 the routines, processes, methods, and algorithms described in the preceding sections may
21 be embodied in, and fully or partially automated by, code modules executed by one or more
22 computers, computer processors, or machines configured to execute computer instructions.
23 The code modules may be stored on any type of non-transitory computer-readable storage
24 medium or tangible computer storage device, such as hard drives, solid state memory, flash
25 memory, optical disc, and/or the like. The processes and algorithms may be implemented
26 partially or wholly in application-specific circuitry. The results of the disclosed processes
27 and process steps may be stored, persistently or otherwise, in any type of non-transitory
28 computer storage such as, e.g., volatile or non-volatile storage.

29 The various features and processes described above may be used independently of
30 one another, or may be combined in various ways. All possible combinations and
31 subcombinations are intended to fall within the scope of this disclosure. In addition, certain

1 method, event, state, or process blocks may be omitted in some implementations. The
2 methods, steps, and processes described herein are also not limited to any particular
3 sequence, and the blocks, steps, or states relating thereto can be performed in other
4 sequences that are appropriate. For example, described tasks or events may be performed
5 in an order other than the order specifically disclosed. Multiple steps may be combined in
6 a single block or state. The example tasks or events may be performed in serial, in parallel,
7 or in some other manner. Tasks or events may be added to or removed from the disclosed
8 example embodiments. The example systems and components described herein may be
9 configured differently than described. For example, elements may be added to, removed
10 from, or rearranged compared to the disclosed example embodiments.

11 Conditional language used herein, such as, among others, "can," "could," "might,"
12 "may," "e.g.," and the like, unless specifically stated otherwise, or otherwise understood
13 within the context as used, is generally intended to convey that certain embodiments
14 include, while other embodiments do not include, certain features, elements and/or steps.
15 Thus, such conditional language is not generally intended to imply that features, elements
16 and/or steps are in any way required for one or more embodiments or that one or more
17 embodiments necessarily include logic for deciding, with or without author input or
18 prompting, whether these features, elements and/or steps are included or are to be
19 performed in any particular embodiment. The terms "comprising," "including," "having,"
20 and the like are synonymous and are used inclusively, in an open-ended fashion, and do
21 not exclude additional elements, features, acts, operations and so forth. Also, the term "or"
22 is used in its inclusive sense (and not in its exclusive sense) so that when used, for example,
23 to connect a list of elements, the term "or" means one, some, or all of the elements in the
24 list. Conjunctive language such as the phrase "at least one of X, Y, and Z," unless
25 specifically stated otherwise, is otherwise understood with the context as used in general
26 to convey that an item, term, etc. may be either X, Y, or Z. Thus, such conjunctive language
27 is not generally intended to imply that certain embodiments require at least one of X, at
28 least one of Y, and at least one of Z to each be present.

29 The term "and/or" means that "and" applies to some embodiments and "or" applies
30 to some embodiments. Thus, A, B, and/or C can be replaced with A, B, and C written in
31 one sentence and A, B, or C written in another sentence. A, B, and/or C means that some

1 embodiments can include A and B, some embodiments can include A and C, some
2 embodiments can include B and C, some embodiments can only include A, some
3 embodiments can include only B, some embodiments can include only C, and some
4 embodiments include A, B, and C. The term “and/or” is used to avoid unnecessary
5 redundancy.

6 The term “about” is used to mean “approximately”. For example, the disclosure
7 includes “The rope may measure about 10 feet in length.” In this context, “about 10 feet”
8 is used to mean “approximately 10 feet”. A range of rope length from 8 feet to 12 feet may
9 be used to fall within the understanding of “about 10 feet”.

10 The term “substantially” is used to mean “completely” or “nearly completely”. For
11 example, the disclosure includes “...the elongate flexible light source 16 comprises a
12 plurality of light sources, such as LEDs, that extend substantially the entire length of the
13 elongate flexible light source 16.” In this context, “substantially the entire length” is used
14 to mean “completely or nearly completely” the entire length. An embodiment where the
15 plurality of light sources extend at least three-quarters of the entire length of the elongate
16 flexible light source would fall within the understanding of “substantially the entire
17 length”.

18 While certain example embodiments have been described, these embodiments have
19 been presented by way of example only, and are not intended to limit the scope of the
20 inventions disclosed herein. Thus, nothing in the foregoing description is intended to imply
21 that any particular feature, characteristic, step, module, or block is necessary or
22 indispensable. Indeed, the novel methods and systems described herein may be embodied
23 in a variety of other forms; furthermore, various omissions, substitutions, and changes in
24 the form of the methods and systems described herein may be made without departing from
25 the spirit of the inventions disclosed herein.

What is claimed is:

1. A convertible light device, comprising:

a housing;

a battery pack coupled to the housing; and

an elongate flexible light source detachably coupled to the housing and electrically coupled to the battery pack, wherein the elongate flexible light source comprises a plurality of LEDs, and wherein the convertible light device is configured to convert between a rope mode and a lantern mode, wherein in the lantern mode, the elongate flexible light source is configured to wrap around an exterior of the housing and in the rope mode, the elongate flexible light source is configured to unwrap and extend from the exterior of the housing.

2. The convertible light device of claim 1, wherein the elongate flexible light source comprises a rope light.

3. The convertible light device of claim 2, wherein the elongate flexible light source comprises a frosted material configured to diffuse light emitted by the plurality of LEDs.

4. The convertible light device of claim 2, wherein the rope light defines a length of about ten feet.

5. The convertible light device of claim 1, the elongate flexible light source comprising a first end coupled to a magnetic end cap and a second end located opposite the first end and detachably coupled adjacent a base portion of the housing, wherein when the convertible light device is in the rope mode, the first end of the elongate flexible light source is configured to extend from the housing and be coupled to an external anchor.

6. The convertible light device of claim 5, wherein when the convertible light device is in the lantern mode, the elongate flexible light source is configured to wrap around the exterior of the housing such that there is at least a single layer of the elongate flexible

light source wrapped around the exterior of the housing, and wherein the magnetic end cap is configured to couple the first end of the elongate flexible light source to the housing adjacent a top portion of the housing.

7. The convertible light device of claim 5, wherein the magnetic end cap comprises a hole configured to receive an attaching mechanism configured to couple the elongate flexible light source to the external anchor.

8. The convertible light device of claim 1, wherein the battery pack comprises a plurality of lithium-ion batteries.

9. The convertible light device of claim 8, the battery pack configured to slideably couple to an interior portion of the housing, such that the battery pack is at least partially held within the housing, the interior portion of the housing further comprising a storage compartment located above the battery pack.

10. The convertible light device of claim 9, further comprising a lid removably coupled to a top portion of the housing, the lid configured to provide access to the storage compartment.

11. The convertible light device of claim 10, wherein the lid is configured to removably couple to an attaching mechanism, the attaching mechanism configured to couple the elongate flexible light source to an external anchor.

12. The convertible light device of claim 1, further comprising a handle coupled to a top portion of the housing, the handle configured to rotate about 180 degrees.

13. The convertible light device of claim 1, further comprising at least one charging port located on the housing, the at least one charging port configured to enable charging of at least one of the battery pack and an external device.

14. The convertible light device of claim 13, further comprising a plurality of battery level indication lights and a battery indication button coupled to the housing, wherein the battery indication button is configured to illuminate at least one battery level indication light of the plurality of battery level indication lights.

15. The convertible light device of claim 1, further comprising a brightness knob located on the housing, the brightness knob configured to control a brightness of light emitted by the plurality of LEDs of the elongate flexible light source.

16. The convertible light device of claim 1, further comprising a power boost button located on the housing, the power boost button configured to amplify a light output of the plurality of LEDs.

17. The convertible light device of claim 1, further comprising an LED located on a base of the housing, the LED configured to operate as a flashlight, wherein the LED is operatively coupled to a flashlight button located on the housing.

18. The convertible light device of claim 1, further comprising a wrapping guide rail located on an exterior of the housing, the wrapping guide rail configured to guide the elongate flexible light source around an exterior of the housing.

19. The convertible light device of claim 1, wherein the housing comprises a base portion, the base portion comprised of a material configured to absorb impact.

20. The convertible light device of claim 1, wherein the housing comprises a top portion, a base portion, and a middle portion, wherein the top portion and the base portion each define a first width and the middle portion defines a second width, wherein the second width is smaller than the first width.

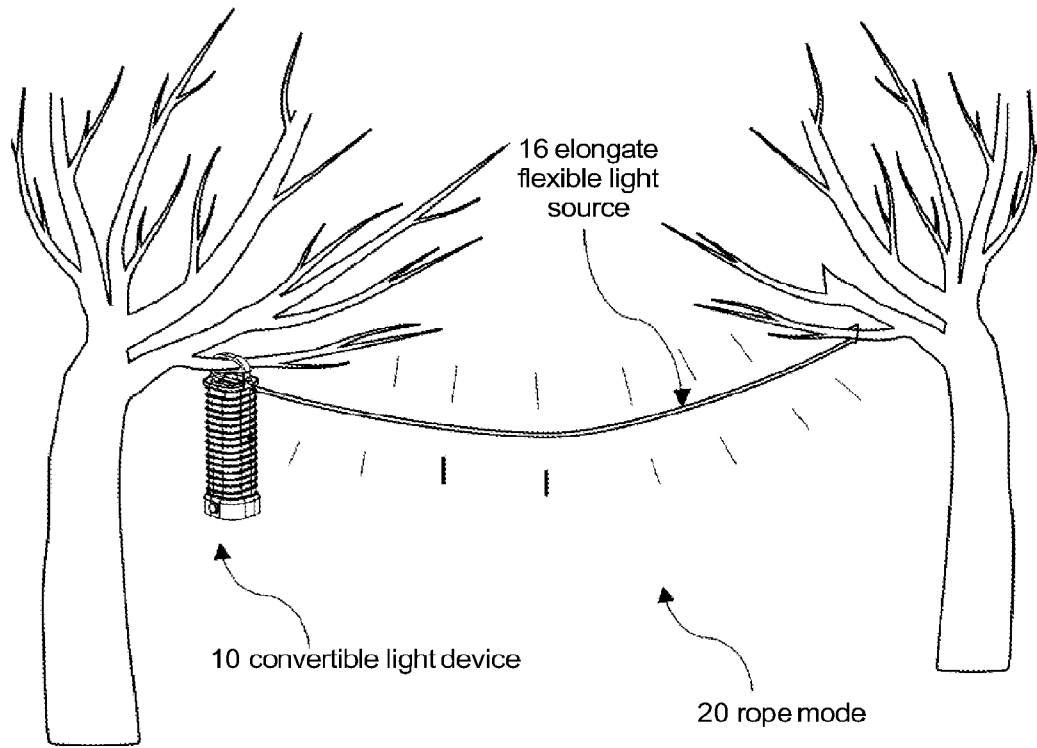

Figure 1A

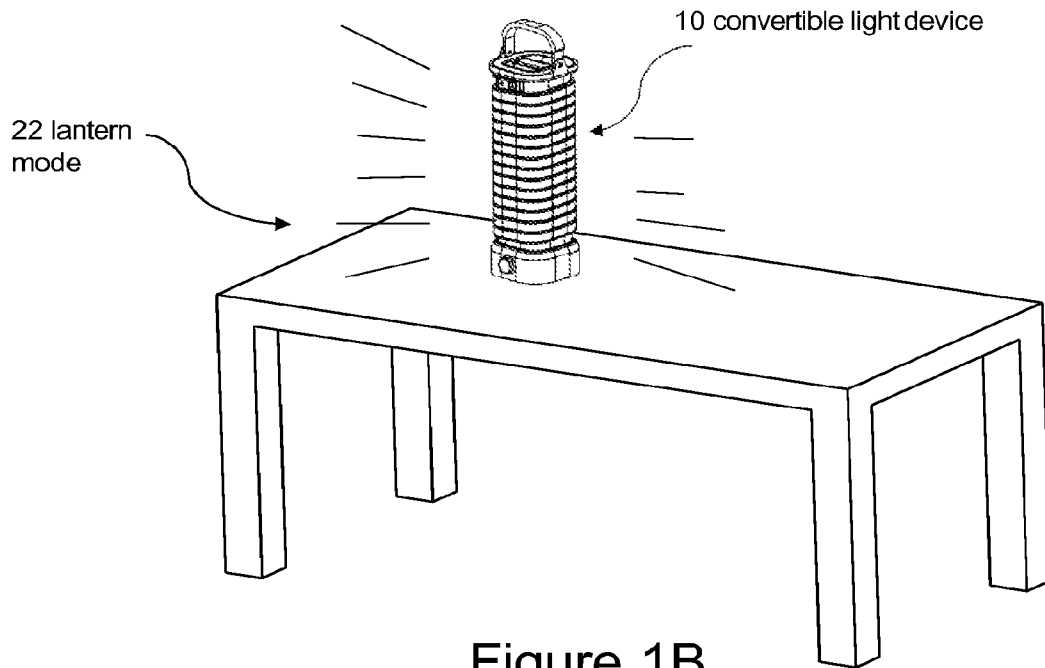

Figure 1B

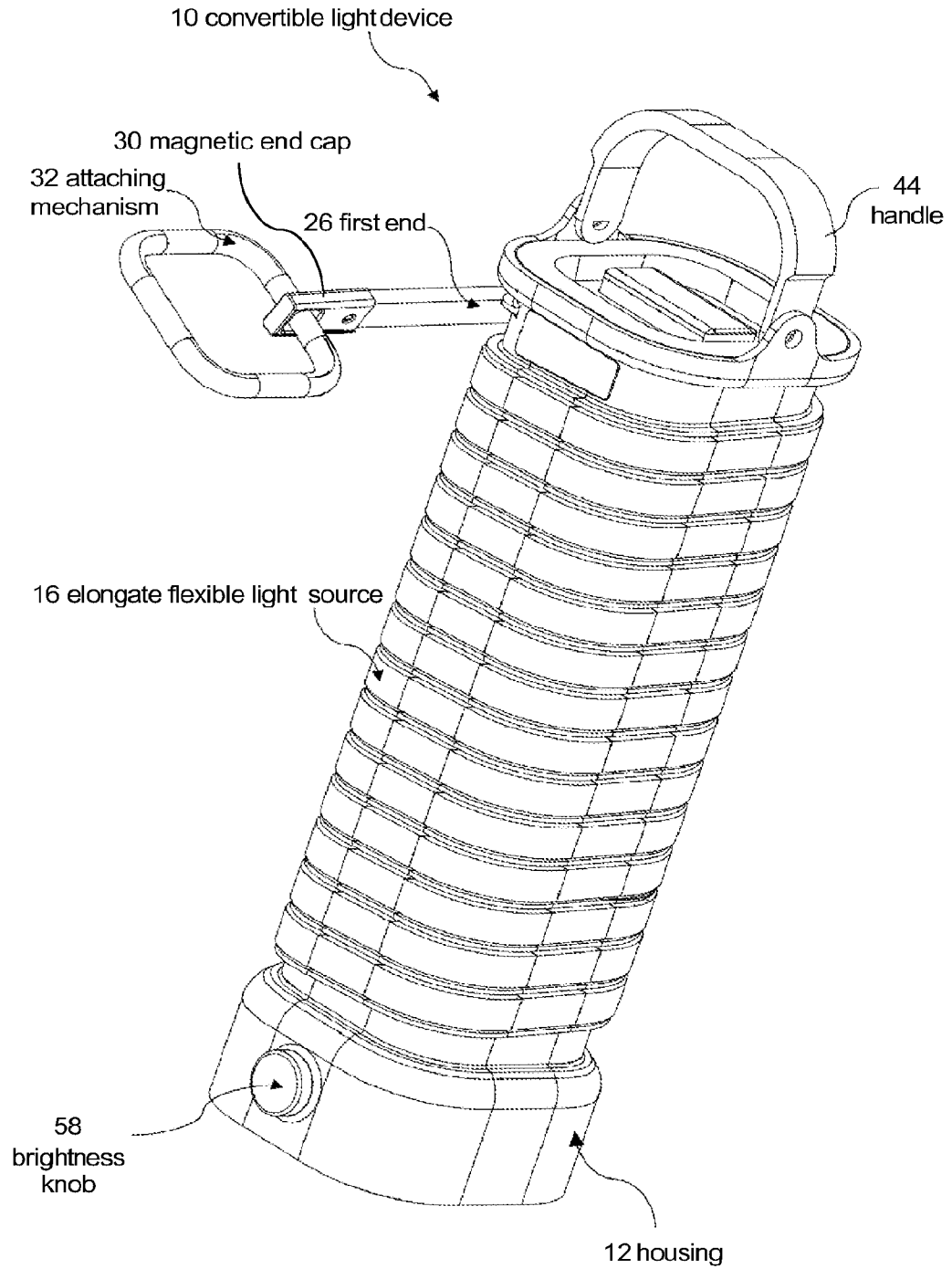

Figure 2

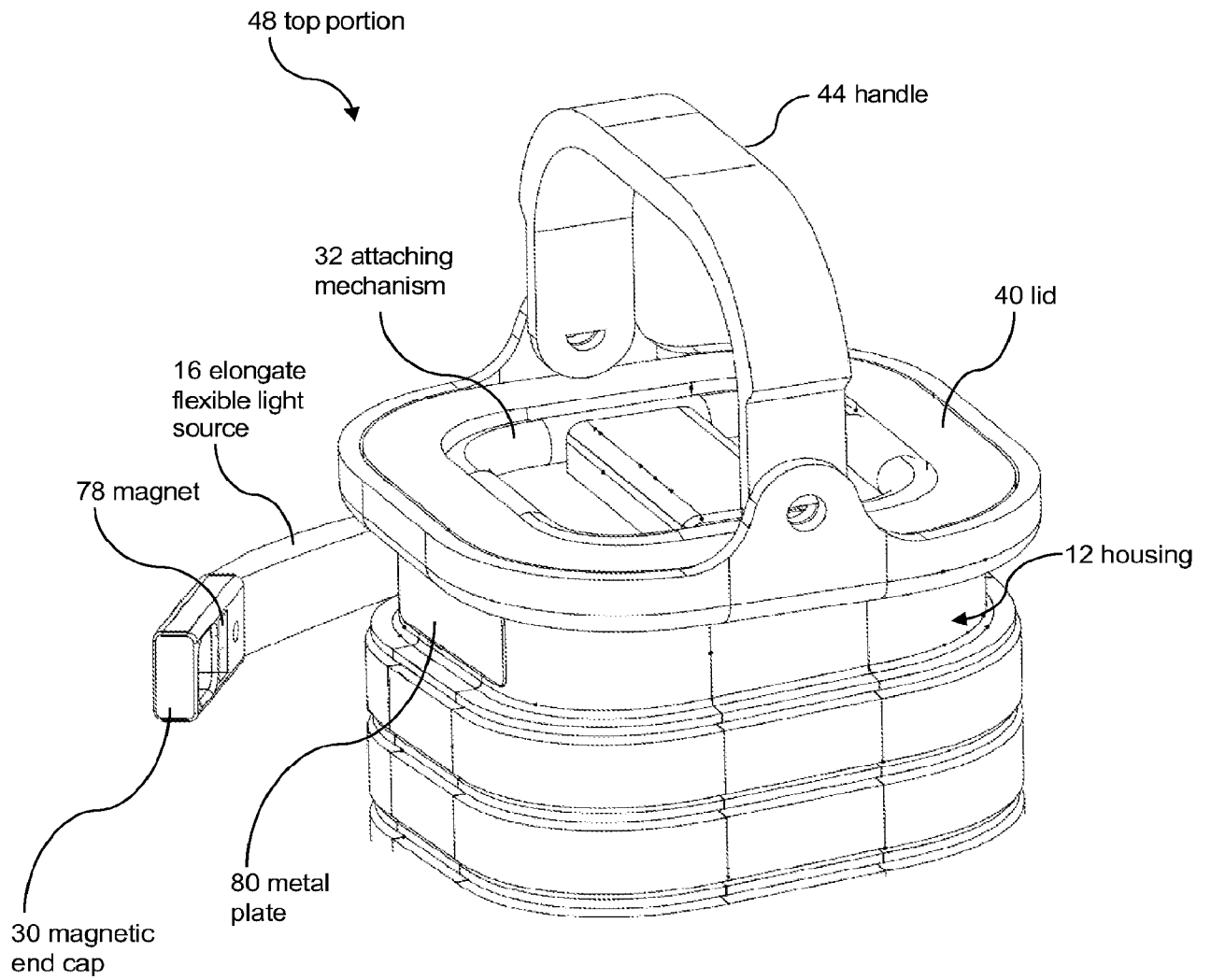

Figure 3

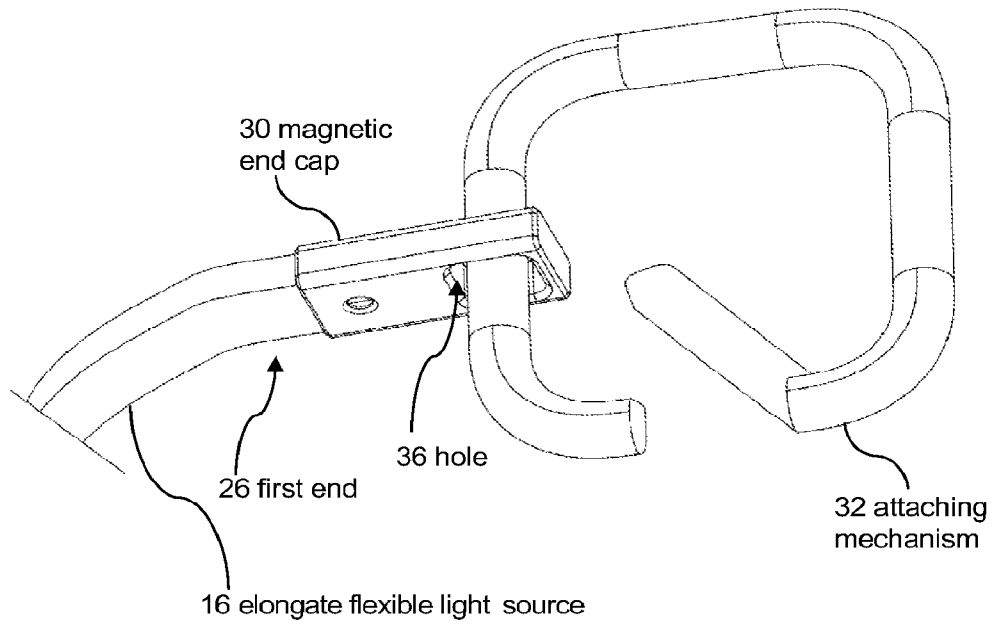

Figure 4

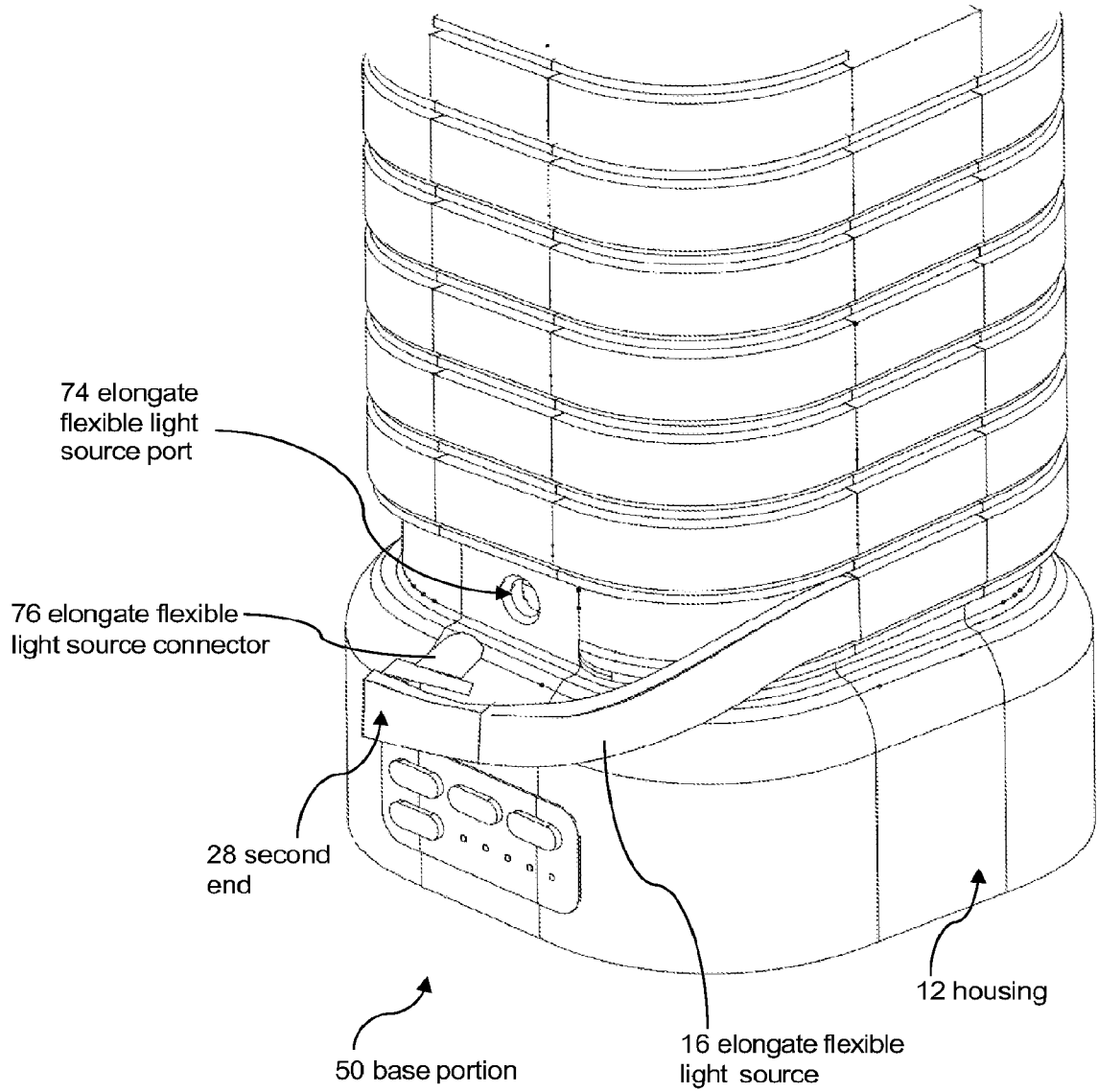

Figure 5

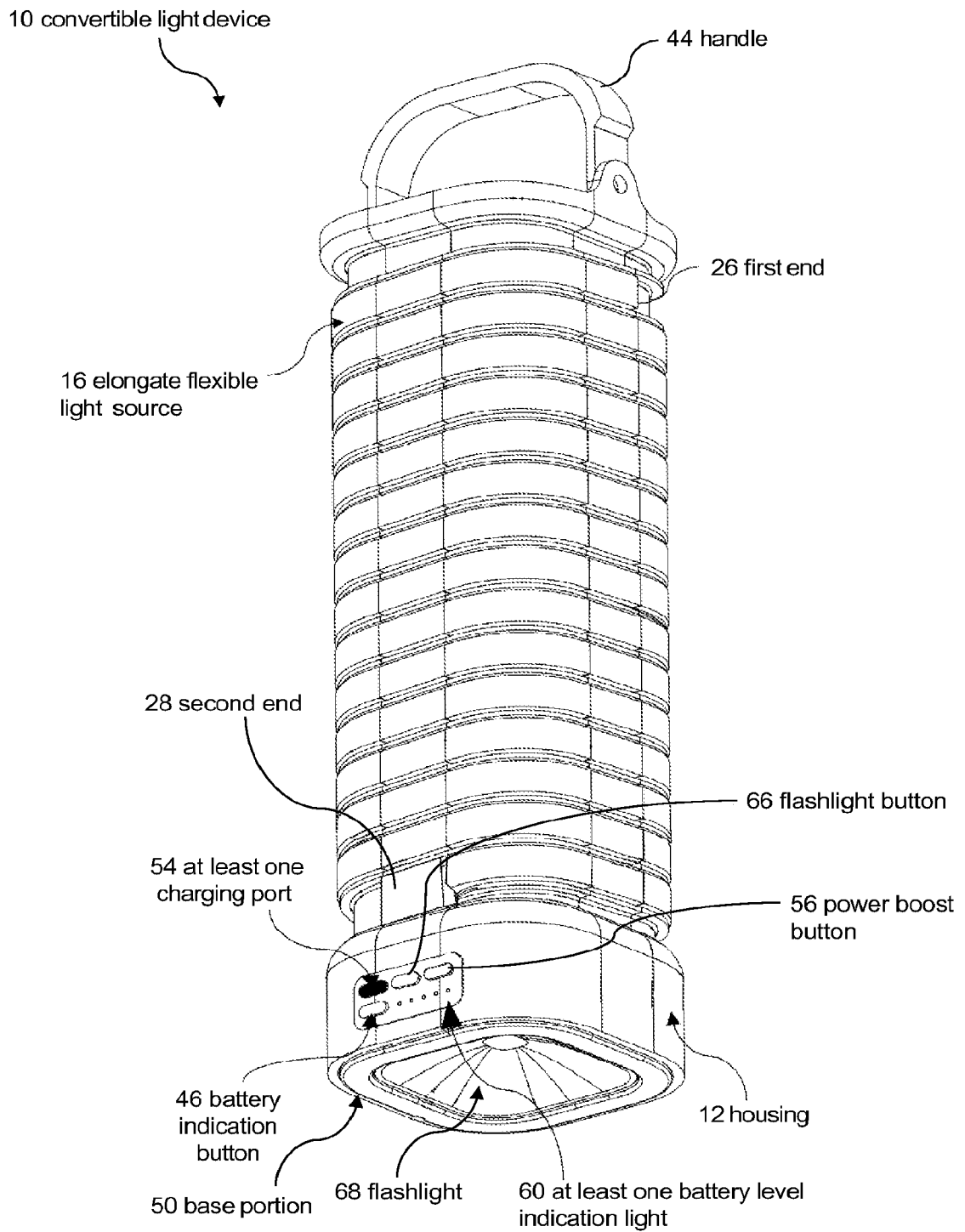

Figure 6

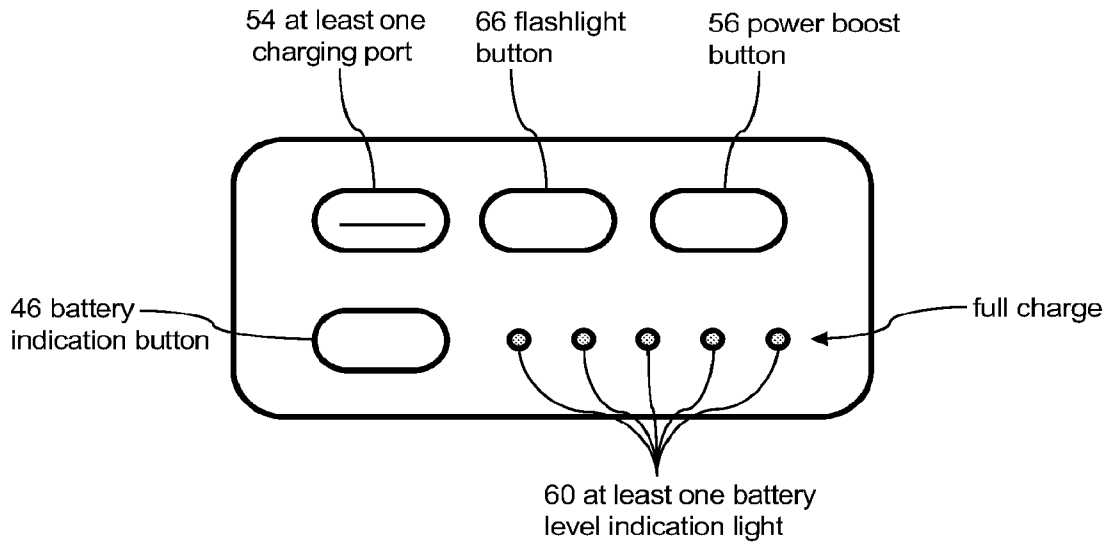

Figure 7A

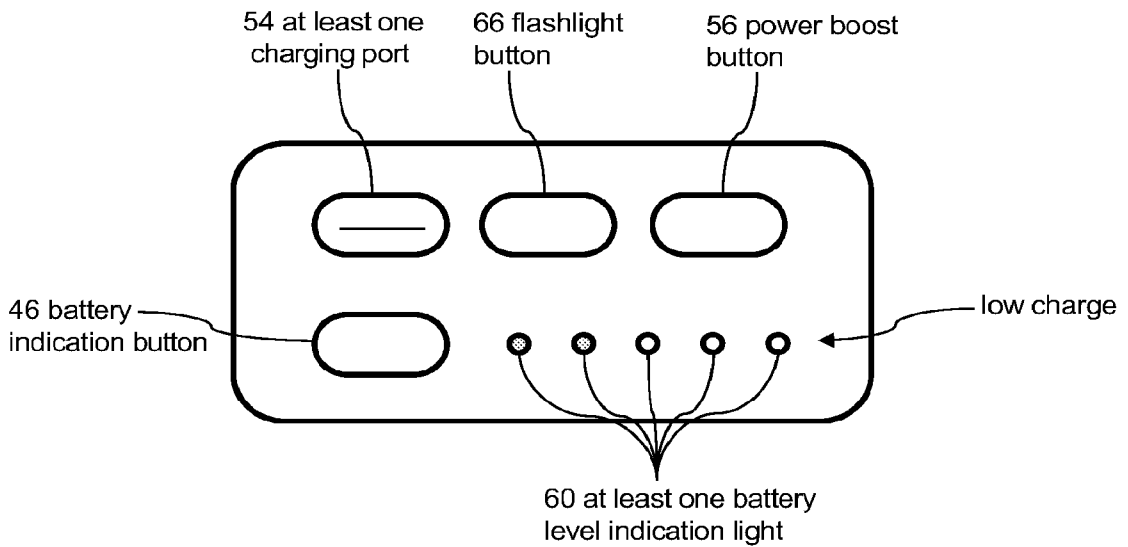

Figure 7B

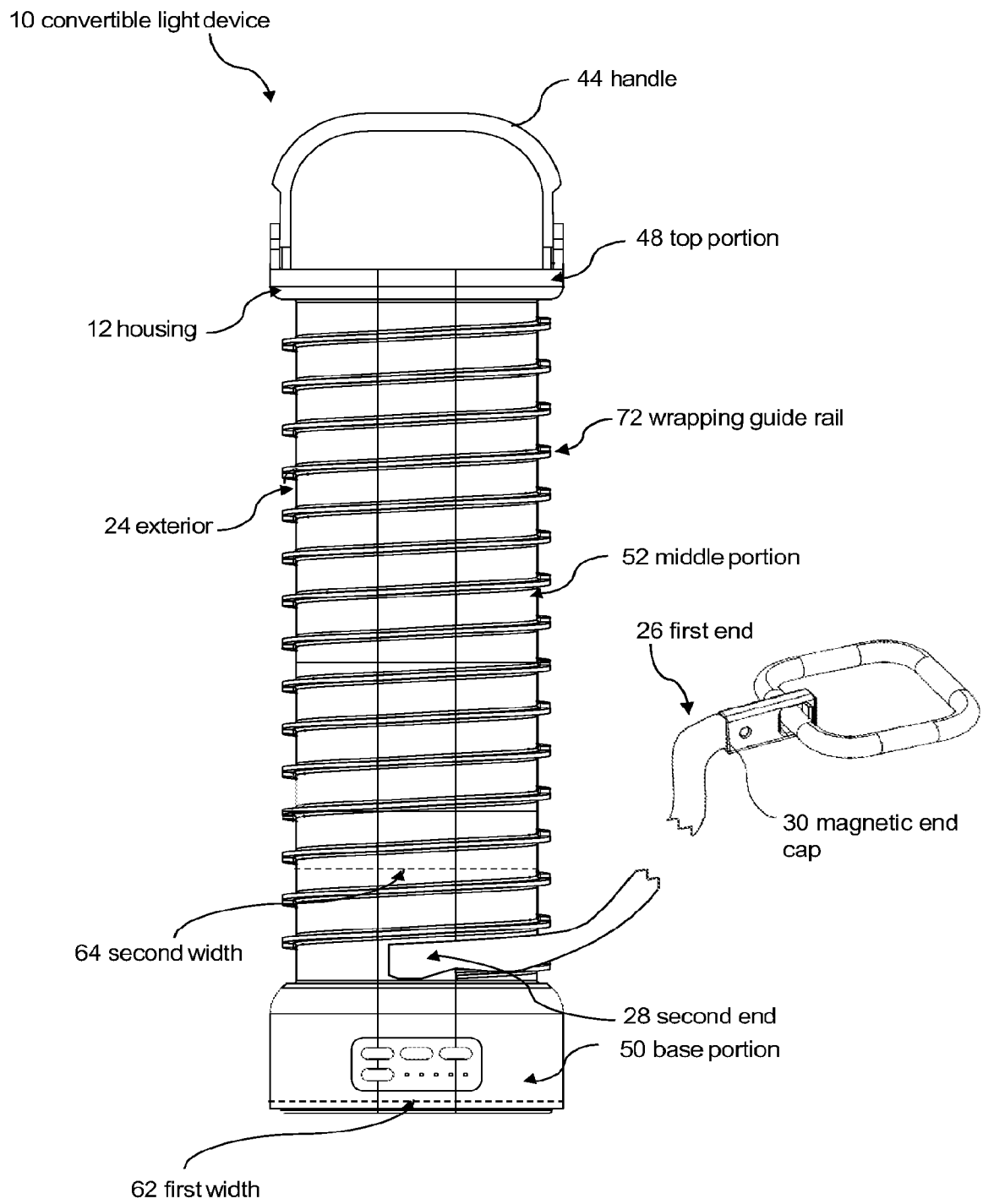

Figure 8

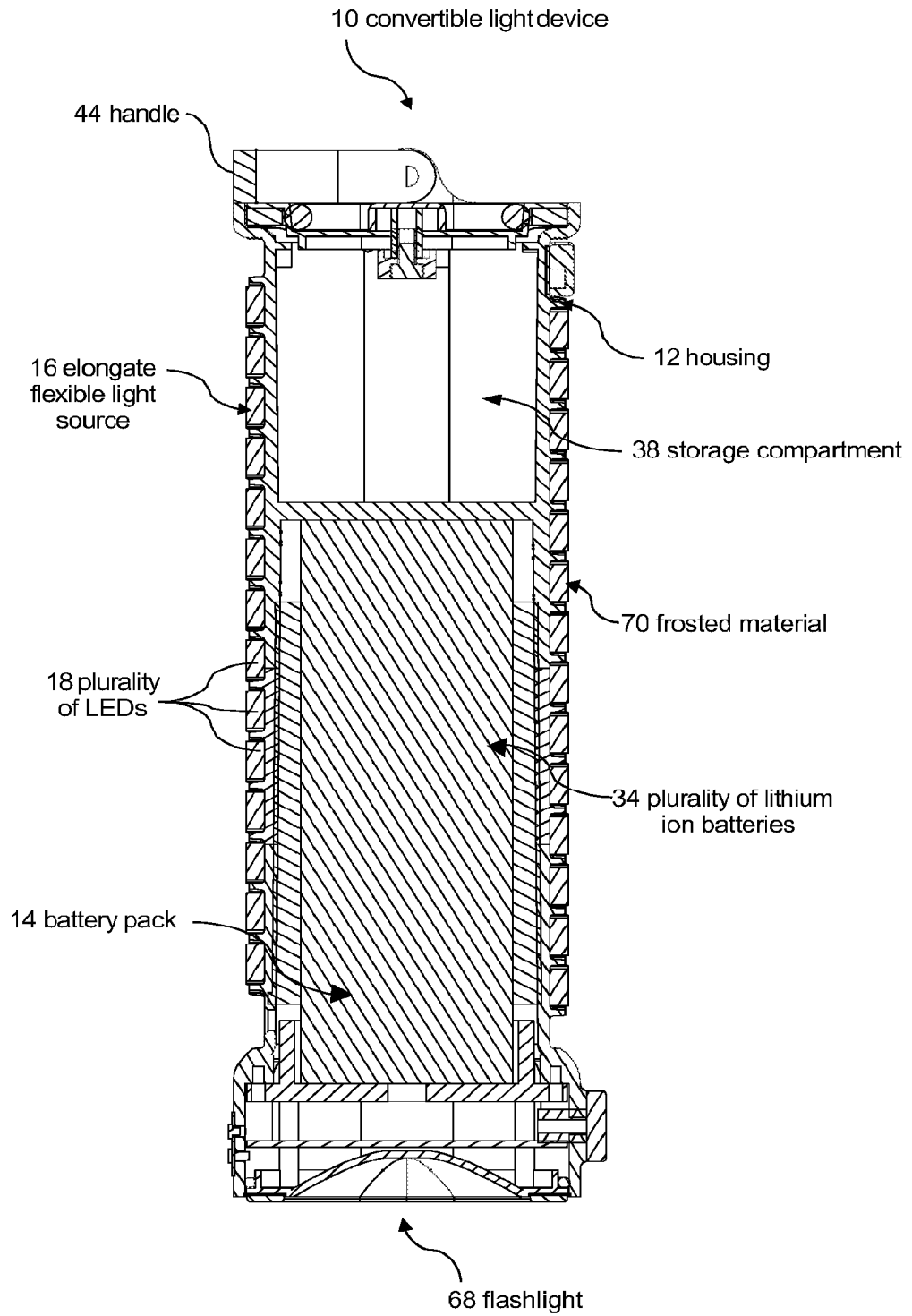
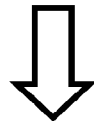
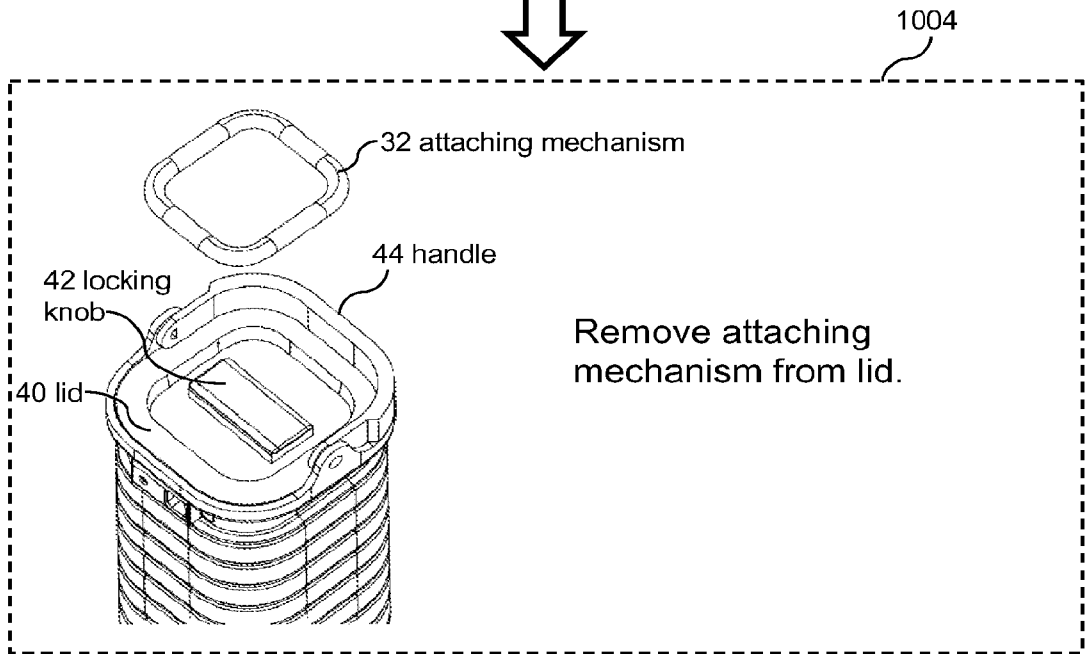
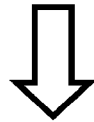
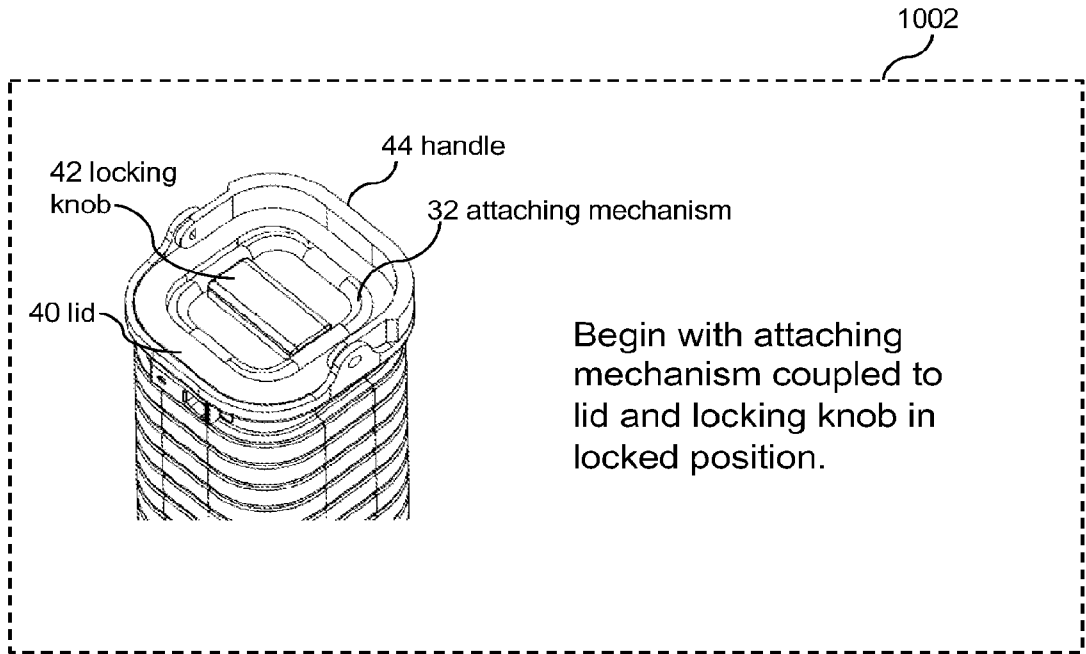

Figure 9



See Fig. 10B

Figure 10A

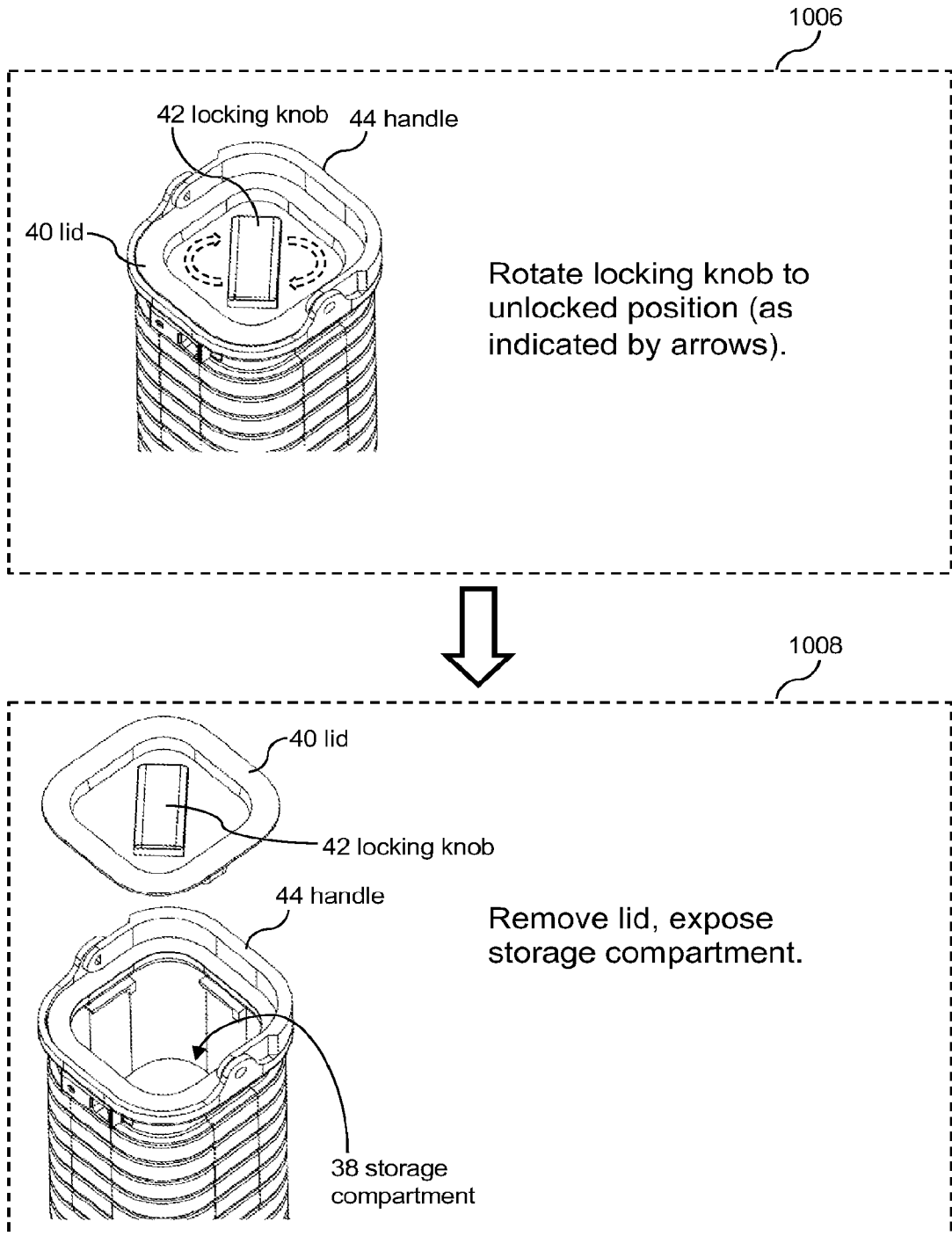

Figure 10B

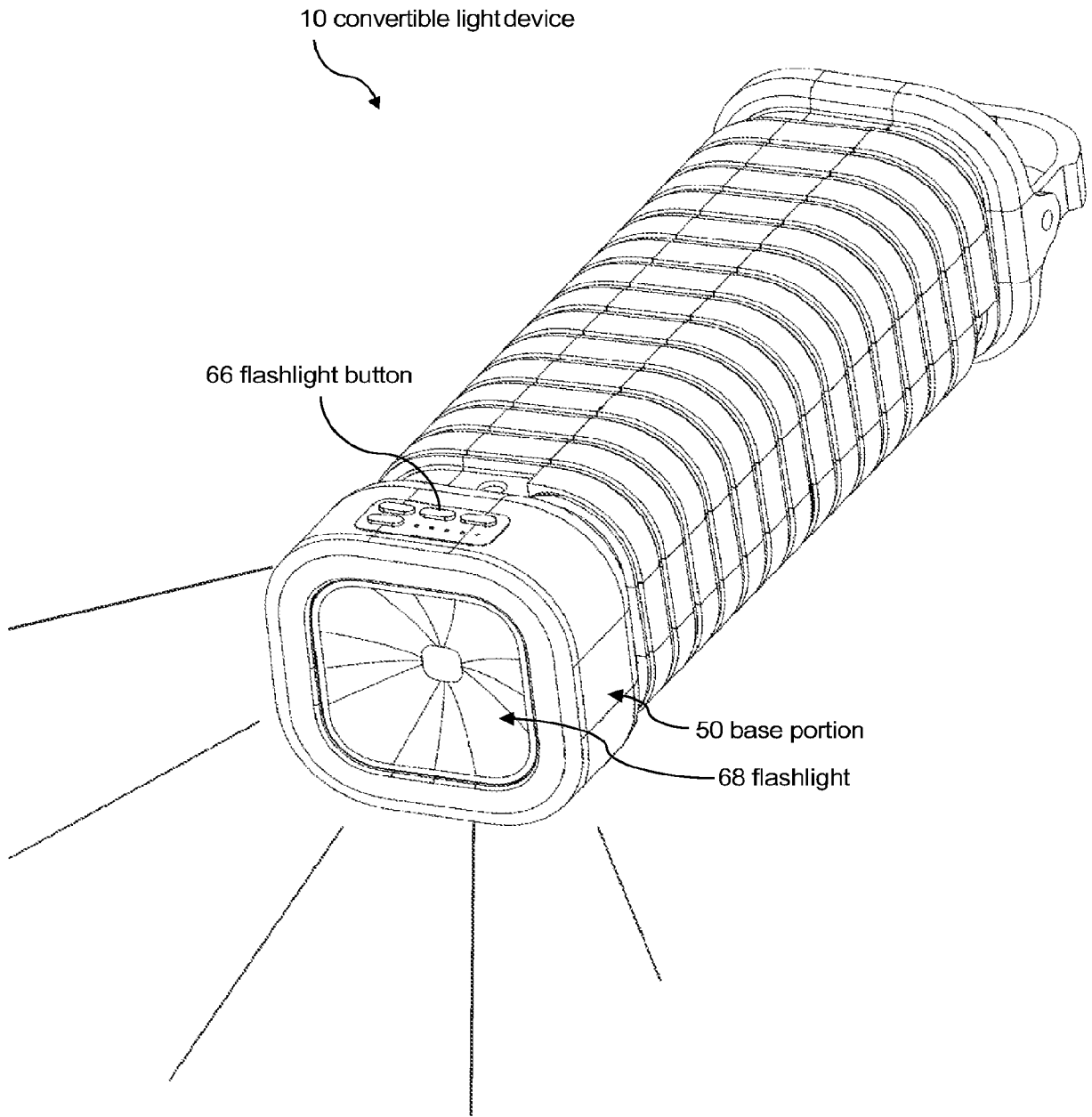

Figure 11

