

A U S T R A L I A

660618

Patents Act 1990

PATENT REQUEST : STANDARD PATENT

We being the persons identified below as the Applicants, request the grant of a patent to the persons identified below as the Nominated Persons, for an invention described in the accompanying standard complete specification.

Full application details follow:

[71/70] Applicant/Nominated Person:

BIO-TECHNOLOGY GENERAL CORP.

Address:

70 Wood Avenue South,
Metro Park Financial Center,
Iselin, New Jersey 08830,
United States of America

[54] Invention Title: Fibrin Binding Domain Polypeptides and uses and methods
of producing same.

[72] Name(s) of actual inventor(s):

VOGEL, Tikva
LEVANON, Avigdor
WERBER, Moshe
GUY, Rachel
PANET, Amos
HARTMAN, Jacob
SHAKED, Hadassa

[74] Address for service in Australia:

DAVIES COLLISON CAVE, Patent Attorneys, of 1 Little Collins Street,
Melbourne, Victoria, Australia. Attorney Code: DM

BASIC CONVENTION APPLICATION(S) DETAILS:

[31] Application No.	[33] Country	Code	[32] Date
526,397	United States of America	US	21 May, 1990

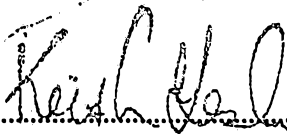
.....

(a member of the firm of DAVIES COLLISON CAVE
for and on behalf of the Applicant).

3 January, 1995

2
3
4
5
6
7
8

AUSTRALIA
PATENTS ACT 1990
NOTICE OF ENTITLEMENT

We, Bio-Technology General Corp. of 70 Wood Avenue South, Metro Park Financial Center, Iselin, New Jersey 08830, United States of America being the applicant/Nominated person in respect of Application No. 80760/91 state the following:-

The Nominated person has entitlement from the actual inventors by assignment. The Nominated person has entitlement from the applicants of the application listed in the declaration made under Article 8 of the PCT by assignment. Except for certain subject matter disclosed in United States Application Serial No. 345,952 filed on 28 April, 1989 and United States Application Serial No. 291,951 filed 29 December, 1988, the basic application listed in the declaration made under Article 8 of the PCT is the first application made in a convention country in respect of the invention.

The Nominated Person is entitled to rely on the deposits listed hereafter because the deposits were made by the depositor on behalf of the Nominated Person at the American Type Culture Collection, Rockville, Maryland USA.

Strain/plasmid	Accession No.	Deposit Date
<u>E. coli</u> pTV 104(2)	39384	29 June, 1983
<u>E. coli</u> pSOD alpha 2	39786	2 August, 1984
<u>E. coli</u> pBLA 11	39788	2 August, 1984
<u>E. coli</u> A3111	53217	6 August, 1985
<u>E. coli</u> A4346	53218	6 August, 1985
<u>E. coli</u> pJBF5401/ <u>E. coli</u> SO540	67359	20 March, 1987
<u>E. coli</u> p18UL-1/ <u>E. coli</u> MC1061	67361	20 March, 1987

<u>E. coli</u> pMF 2005/ <u>E. coli</u> SO732	67362	20 March, 1987
<u>E. coli</u> S phi 930 (F ⁻)/pMF 5534	67703	23 May, 1988
<u>E. coli</u> W3110 (F ⁻)/pMFS 929	67705	23 May, 1988
<u>E. coli</u> S phi 930/pEFF 920	67706	23 May, 1988
<u>E. coli</u> A4255, pFN 208-13	68456	1 November, 1990
<u>E. coli</u> 4300/pMLK 100	68605	16 April, 1991
<u>E. coli</u> pFN 203-2	68606	16 April, 1991
<u>E. coli</u> pFN 975-25	67832	26 October, 1988
<u>E. coli</u> pFN 949-2	67831	26 October, 1988
<u>E. coli</u> pFN 137-2	67910	10 March, 1989
<u>E. coli</u> pFN 196-2	68328	16 May, 1990

DATED this 21st day of March, 1995

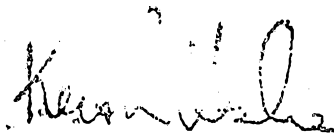

.....
a member of the firm of
DAVIES COLLISON CAVE
for and on behalf of the
applicant(s)

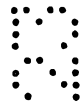
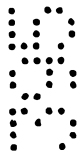
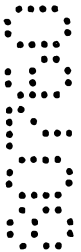



AU9180760

(12) PATENT ABRIDGMENT (11) Document No. AU-B-80760/91
(19) AUSTRALIAN PATENT OFFICE (10) Acceptance No. 660618

- (54) Title
FIBRIN BINDING DOMAIN POLYPEPTIDES AND USES AND METHODS OF PRODUCING SAME
- (51)^s International Patent Classification(s)
C07K 013/00 A61K 037/10 A61K 047/42 C07H 015/12
C12N 001/22 C12N 015/11 G01N 033/68
- (21) Application No. : 80760/91 (22) Application Date : 21.05.91
- (87) PCT Publication Number : WO91/17765
- (30) Priority Data
- (31) Number (32) Date (33) Country
526397 21.05.90 US UNITED STATES OF AMERICA
- (43) Publication Date : 10.12.91
- (44) Publication Date of Accepted Application : 06.07.95
- (71) Applicant(s)
BIO-TECHNOLOGY GENERAL CORP.
- (72) Inventor(s)
TIKVA VOGEL; AVIGDOR LEVANON; MOSHE WERBER; RACHEL GUY; AMOS PANET; JACOB HARTMAN; HADASSA SHAKED
- (74) Attorney or Agent
DAVIES COLLISON CAVE , 1 Little Collins Street, MELBOURNE VIC 3000
- (56) Prior Art Documents
US 4734362
EP 349342
WO 89/00051
- (57) Claim

1. An imaging agent which comprises a polypeptide labeled with an imageable marker, such polypeptide having an amino acid sequence substantially identical to a sequence present in the fibrin binding domain of naturally-occurring human fibronectin, being capable of binding to fibrin, having a molecular weight above about 6 kD but less than about 20 kD, and having the amino acid sequence, gln-ala-gln-gln or met-gln-ala-gln-gln at the N-terminus of the polypeptide.
19. A method for imaging a fibrin-containing substance in a subject which comprises:

- (a) administering to the subject a composition of claim 6 under conditions permitting the imaging agent contained therein to enter the blood stream and bind to fibrin present in the blood vessels;

(11) AU-B-80760/91
(10) 660618

-2-

(b) imaging bound agent within the blood vessels; and thereby

(c) imaging the fibrin-containing substance.

28. A plasmid for expression of a polypeptide having an amino acid sequence substantially present in the fibrin binding domain of naturally-occurring human fibronectin, being capable of binding to fibrin, having a molecular weight above about 6 kD but less than about 20 kD, and having the amino acid sequence gln-ala-gln-gln or met-gln-ala-gln-gln at the N-terminus of the polypeptide comprising DNA encoding the polypeptide and DNA encoding suitable regulatory elements positioned relative to the DNA encoding the polypeptide so as to effect expression of the polypeptide in a suitable host cell.

67. A method for recovering a purified, biologically active polypeptide having an amino acid sequence substantially present in the fibrin binding domain of naturally-occurring human fibronectin, being capable of binding to fibrin, having a molecular weight of about 6 Kd but less than 20 Kd, and having the amino acid sequence gln-ala-gln-gln or met-gln-ala-gln-gln at the N terminus of the polypeptide, which comprises:

(a) producing in a bacterial cell by means of expression of a plasmid containing DNA encoding the polypeptide a first polypeptide having the amino acid sequence of the polypeptide but lacking the disulfide bond;

(b) disrupting the cell so as to produce a lysate containing the first polypeptide;

(c) centrifuging the lysate so as to concentrate the first polypeptide;

(d) separating the concentrated first polypeptide;

(e) solubilizing the separated, concentrated first polypeptide;

(11) AU-B-80760/91

-3-

(10) 660618

- (f) refolding and reoxidizing the solubilized first polypeptide so as to form the biologically active polypeptide;
- (g) separating the refolded and reoxidized biologically active polypeptide;
- (h) recovering the purified, refolded and reoxidized biologically active polypeptide; and
- (i) purifying the biologically active polypeptide so recovered.

PCT

INTERNATIONAL APPLICATION PUBLISHED UNDER THE PATENT COOPERATION TREATY (PCT)

<p>(51) International Patent Classification ⁵ : A61K 37/10, C07H 15/12 C12P 21/06, C12N 1/22</p>	<p>A1</p>	<p>(11) International Publication Number: WO 91/17765 (43) International Publication Date: 28 November 1991 (28.11.91)</p>
<p>(21) International Application Number: PCT/US91/03584 (22) International Filing Date: 21 May 1991 (21.05.91) (30) Priority data: 526,397 21 May 1990 (21.05.90) US (71) Applicant: BIO-TECHNOLOGY GENERAL CORP. [US/US]; 1250 Broadway, New York, NY 10001 (US). (72) Inventors: VOGEL, Tikva ; 4, Kosover Street, 76 100 Rehovot (IL). LEVANON, Avigdor ; 8, Mohliver Street, 76 100 Rehovot (IL). WERBER, Moshe ; 36, Burla Street, 61 999 Tel Aviv (IL). GUY, Rachel ; 23, Miller Street, 76 100 Rehovot (IL). PANET, Amos ; 11, Harav Schrim Street, 91 999 Jerusalem (IL). HARTMAN, Jacob ; 30, Kedoshei Kahir Street, 58 100 Holon (IL). SHAKED, Hadassa ; 3, Tirza Street, 52 100 Ramat Gan (IL).</p>	<p>(74) Agent: WHITE, John, P.; Cooper & Dunham, 30 Rockefeller Plaza, New York, NY 10112 (US). (81) Designated States: AT (European patent), AU, BE (European patent), BR, CA, CH (European patent), DE (European patent), DK (European patent), ES (European patent), FI, FR (European patent), GB (European patent), GR (European patent), HU, IT (European patent), JP, KR, LU (European patent), NL (European patent), NO, SE (European patent), SU. Published <i>With international search report. Before the expiration of the time limit for amending the claims and to be republished in the event of the receipt of amendments.</i></p>	

660618

(54) Title: FIBRIN BINDING DOMAIN POLYPEPTIDES AND USES AND METHODS OF PRODUCING SAME

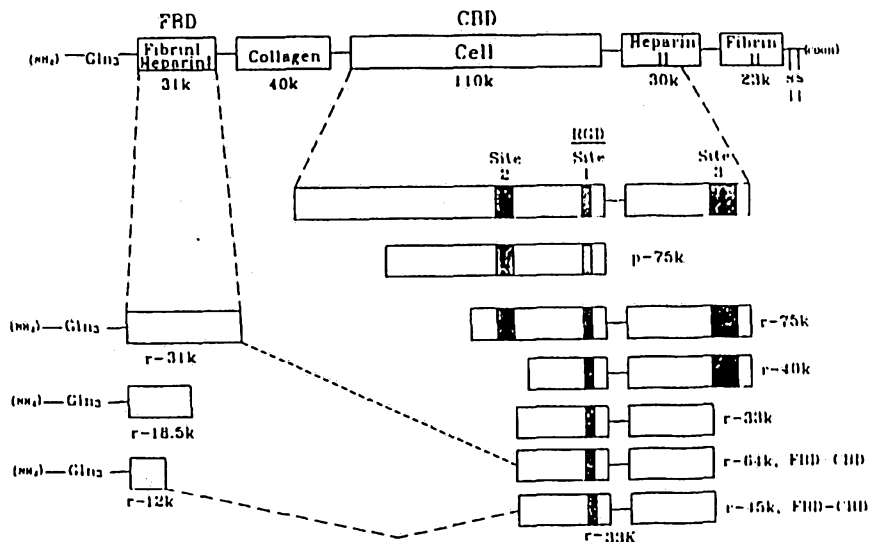

(57) Abstract

This invention provides an imaging agent which comprises a polypeptide labeled with an imageable marker, such polypeptide having an amino acid sequence substantially present in the fibrin binding domain of naturally-occurring human fibronectin and being capable of binding to fibrin. The invention further provides a method wherein the imaging agent is used for imaging a fibrin-containing substance, i.e., a thrombus or atherosclerotic plaque. Further provided are plasmids for expression of polypeptides having an amino acid sequence substantially present in the fibrin binding domain of naturally-occurring human fibronectin and being capable of binding to fibrin, hosts containing these plasmids, methods of producing the polypeptides, methods of treatment using the polypeptides, and methods of recovering, refolding and reoxidizing the polypeptides. The invention also provides for purified polypeptides substantially free of other substances of human origin which have an amino acid sequence substantially present in the fibrin binding domain of naturally-occurring human fibronectin and which are capable of binding to fibrin.

FIBRIN BINDING DOMAIN POLYPEPTIDES
AND USES AND METHODS OF PRODUCING SAME

This application is a continuation-in-part of U.S. Serial No. 526,397, filed May 21, 1990.

Background of the Invention

Throughout this application, various publications are referenced by Arabic numerals within parentheses. Full citations for these references may be found at the end of the specification immediately preceding the claims. The disclosures of these publications in their entireties are hereby incorporated by reference in this application in order to more fully describe the state of the art to which this invention pertains.

Endothelial injury is believed to be an initial step in thrombus formation and may be caused by, e.g., hemodynamic strain, hypercholesterolemia, hypertension and immune complex disease. Endothelial injury leads to thickening of the intima, cell proliferation, cholesterol accumulation, and formation of connective tissue fibers. IgG and complement factor C3 accumulation in injured endothelial cells and nonendothelialized intima has been observed. Mononuclear cells derived from blood are also part of the cell population in atherosclerotic lesions. The mechanism of plaque formation is not fully known. However, a probable mechanism is that the earliest lesions, fatty streaks, consisting of mixtures of T cells and monocyte-derived macrophages, form in the subendothelium followed by a secretion of various cytokines, which leads to a migration of smooth cells into the intima and their accumulation therein.

Most existing procedures for the diagnosis and treatment of atherosclerosis and thrombosis are invasive, costly, and of limited effectiveness in a significant percentage of patient cases.

5

The concept of plaque enhancement by application of a stain has been reported [Spears, J. et al., J. Clin. Invest. 71: 395-399 (1983)]. These stains mark the plaque surfaces with a fluorescent compound. Plaque destruction by photoactivation of hematoporphyrin derivatives using an intraluminal laser-transmitting optical fiber has been suggested [Abela, G. et al., Am. J. Cardiol. 50: 1199-1205 (1982)]. Moreover, tetracycline stains have also been suggested. [Murphy-Chutorian, D. et al., Am. J. Cardiol. 55: 1293-1297 (1985)].

10
15

The above-identified stains were selected for their ability to bind to components of the atherosclerotic plaque. In principle, the stain absorbs laser light concentrating the light at the stained surface. Some staining of healthy tissue occurs causing stain associated damage to the surrounding tissue. Because laser light wavelength is limited to the absorption wavelength of the stain, chromophores offering optimum absorption of laser light must be used to provide best controlled ablation.

20
25

Imaging and detection of coronary thrombi, pulmonary emboli, deep venous thrombosis and atherosclerotic lesions are of great clinical importance especially in view of the new thrombolytic agents which have recently been developed. Several experimental approaches for non-invasive detection of thrombi by use of radiopharmaceutical agents have been reported but none has gained wide clinical recognition because of intrinsic drawbacks associated with each agent.

30
35

The basic characteristics of a radiopharmaceutical for early detection of intravascular atherosclerotic lesions and thrombi are the following: (i) high affinity for thrombus components; (ii) relatively fast pharmacokinetic blood clearance rate [in order to obtain a high ratio of thrombus (bound) to blood (unbound) radiolabeled tracer]; (iii) safety: non-toxic and non-immunogenic; and (iv) simplicity of preparation and use.

10 The various agents for imaging thrombi described in the literature and their drawbacks are as follows: (a) autologous platelets labeled with ^{111}In : the procedure is cumbersome, time consuming and the blood clearance time is relatively long, viz. 2 days (2); (b) ^{131}I -fibrinogen: the
15 assay is based on the (low) affinity of injected radiolabeled fibrinogen for the thrombus but it is not suitable for rapid imaging tests because of its long residence time in blood and furthermore it does not become incorporated into older thrombi nor is it incorporated in
20 the presence of heparin (3, 36); (c) fragment E1 of human fibrin: although it seems superior to fibrinogen it is difficult to prepare in sufficient quantities for widespread clinical use (4); (d) mouse anti-fibrin monoclonal antibodies: although they are specific and have high
25 affinities for thrombi, they have a relatively long blood clearance time and are potentially immunogenic to human subjects (5, 33, 34); (e) mouse monoclonal antibodies specific for activated platelets (6, 7): disadvantage as (d); and (f) labeled fibronectin (1): although fibronectin
30 (see below) has an affinity for a number of substances occurring in thrombi it has a relatively long blood clearance time and the buildup of radioactivity in the thrombus is slow. Thus there is a need in the art for a thrombus-specific radiopharmaceutical for rapid imaging of
35 thrombi.

U.S. Patent 4,343,734 (Lian et al.) describes specific gamma-carboxyglutamic acid (GLA) antibodies which can be labeled with fluorescein for immunofluorescence staining of tissue to determine the presence therein of GLA. Specific
5 GLA antibodies bind to GLA which is present in advanced atherosclerotic plaque, having calcium deposits. Lian et al. report that GLA is not found in uncalcified plaques and that GLA is found in cardiac valves and aortas, and in
10 circulating proteins such as prothrombin, clotting factors VII, IX and X, Protein C and Protein S. However, the GLA binding antibodies of Lian et al. do not selectively bind to atherosclerotic plaques.

Fibronectin is a glycoprotein composed of two identical
15 subunits each of approximately 220,000 molecular weight. Two major forms of fibronectin are produced and secreted by human cells in culture and in vivo (8). The cell-associated fibronectin is relatively insoluble and participates in cell adhesion, wound healing, cell differentiation and
20 phagocytosis. The plasma fibronectin, produced primarily in the liver, is a soluble serum protein with biological properties similar to those of cell fibronectin.

Fibronectin is considered a multifunctional modular protein
25 since limited proteolytic cleavage produces polypeptides with distinct activities. The major functional domains of the fibronectin molecule have been obtained and defined by partial proteolytic digestion, and include heparin, DNA, fibrin, collagen or gelatin, and cell binding domains (8-
30 13).

Baralle, F.E., European Patent Publication No. 207,751, published January 7, 1989, discloses the complete cDNA
35 sequence of fibronectin. Baralle also discloses the expression of fusion proteins containing a portion of the collagen binding domain of fibronectin fused to the

Escherichia coli protein β -galactosidase. Similar fusion proteins are disclosed by Owens and Baralle (14). Obara et al. (1987) disclose the expression of a portion of the cell binding domain of human fibronectin fused to Escherichia coli β -galactosidase (15). Additionally, Obara et al. (1988) disclose the expression of portions of the cell binding domain fused to β -galactosidase which have been mutagenized, i.e., site specific deletions of portions of the cell binding domain were obtained as fused proteins (16). The carboxy terminal fibrin-binding domain of human fibronectin has been expressed in mouse L cells as a fusion protein with the signal sequence of human protein C inhibitor (17).

None of the above references discloses the expression of the N-terminal fibrin binding domain of fibronectin; furthermore all the recombinant proteins they disclose are fusion proteins.

This invention provides polypeptides having an amino acid sequence substantially present in the N-terminal fibrin binding domain of fibronectin. These polypeptides have approximate molecular weights of 31 kD, 20 kD, 18.5 kD and 12 kD, as defined by comparison markers on SDS gels under reducing conditions, and have the following characteristics which make them promising pharmaceutical agents: (i) have an amino acid sequence present in a human protein and thus are contemplated to not be immunogenic; (ii) have specificity to fibrin based on their ability to become covalently cross-linked in a trans-glutaminase catalysed reaction to nascent as well as to preformed thrombi (clots); (iii) bind to extracellular matrix, which property may be exploited to detect atherosclerotic plaques; (iv) have a relatively short blood clearance time; (v) incorporate into clots in the presence of heparin; and (vi) are produced by

recombinant techniques and can therefore potentially be manufactured on a large scale.

5 The subject invention provides an inexpensive, accurate method for imaging fibrin-containing substances, i.e., a thrombus and atherosclerotic plaque, both in vitro and in vivo. In addition, the subject invention provides plasmids for expressing polypeptides having an amino acid sequence substantially present in the fibrin binding domain of
10 naturally-occurring human fibronectin and capable of binding to fibrin which are labeled and used for imaging the fibrin-containing substances, and methods of producing such polypeptides.

Summary of the Invention

This invention provides imaging agents which comprise polypeptides labeled with an imageable marker, such
5 polypeptide having an amino acid sequence substantially present in the fibrin binding domain of naturally-occurring human fibronectin and being capable of binding to fibrin.

Further provided is a method for imaging a fibrin-containing
10 substance, i.e. a thrombus or atherosclerotic plaque, which comprises contacting the fibrin-containing substance to be imaged with the imaging agent disclosed above under conditions such that the agent binds to the fibrin-containing substance and imaging the bound agent and thereby
15 imaging the fibrin-containing substance.

Also provided is a plasmid for expression of a polypeptide which having an amino acid sequence substantially present in the fibrin binding domain of naturally-occurring human
20 fibronectin and being capable of binding to fibrin comprising DNA encoding the polypeptide and DNA encoding suitable regulatory elements positioned relative to the DNA encoding the polypeptide so as to effect expression of the polypeptide in a suitable host cell.

25 The invention also provides a purified polypeptide substantially free of other substances of human origin which has an amino acid sequence substantially present in the fibrin binding domain of naturally-occurring human
30 fibronectin and being capable of binding to fibrin.

Further provided are methods of recovering and refolding and reoxidizing such polypeptides and methods of treatment using such polypeptides.

35

Brief Description of the Figures

In the figures, the numbers in brackets adjacent certain of the restriction enzyme sites shown correspond to the
5 identically numbered positions along the nucleotide sequence of human fibronectin cDNA as shown in Figure 2 (see also Figure 3 of Baralle, F.E., European Patent Publication No. 207,751, published January 7, 1987).

10 The following figures describe the construction of plasmids expressing polypeptides having an amino acid sequence substantially present in the amino-terminal fibrin binding domain (FBD) of fibronectin. The FBD commences at amino acid number 1 of mature fibronectin, which is glutamine and
15 corresponds to the fourth amino acid (Q) shown in Figure 2A, i.e., the N-terminus of the FBD sequence is Q-A-Q-Q (glutamine-alanine-glutamine-glutamine); the corresponding first nucleotide in the cDNA sequence of Figure 2A is therefore number 14, indicated by an arrow. All the recombinant FBD
20 polypeptides described in these figures and throughout the specification are numbered from this first glutamine as amino acid number 1 and all the corresponding cDNA sequences are numbered as shown in Figure 2.

25 Some of the figures describe the construction of plasmids expressing an FBD polypeptide joined at its C-terminus to part of the cell binding domain (CBD) of fibronectin. The cDNA sequence corresponding to the CBD which applicants have cloned and expressed is missing the 270 bp extra domain (ED)
30 segment which extends from nucleotides 4811 to 5080, inclusive, on the Baralle map (see Figure 2). Thus, the cDNA sequence which is said to extend from nucleotide 3317 to 5566 on the Baralle map, contains only 1980 nucleotides, because it is missing the 270 nucleotides of the ED segment,
35 namely from nucleotides 4811 to 5080 inclusive; this region is also known in the art as the ED-A region. Because

nucleotide 5081 is changed from G to A, the amino acid 1690 is changed from alanine to threonine. Similarly, the polypeptide expressed by that DNA fragment would encode from amino acid 1102 to amino acid 1851 on the Baralle map but
5 would be missing the 90 amino acids encoded by the ED region, namely amino acids 1600-1689 inclusive, and thus it would contain only 660 amino acids. This is true for all CBD polypeptides described in this application which span the ED region. (The region known in the art as the ED-B
10 region is missing both in Baralle's sequence and in applicants' DNA.)

The definition of the polypeptides expressed as 31 kD, 20 kD, 18.5 kD, 12 kD and 33 kD is an operational definition,
15 based on their approximate molecular weight determined on SDS polyacrylamide gels under reducing conditions compared to that of markers of known molecular weight.

Figure 1. This figure is a schematic description of the
20 various fibronectin domains and the recombinant polypeptides constructed.

Figure 2. This figure shows the nucleotide sequence of
human fibronectin cDNA.

25

Figure 3. Seven pairs of chemically synthesized oligomers were prepared. The synthetic oligomers code for the first 153 N-terminal amino acids of human fibronectin (FN). This figure shows the sequence of these 7 pairs of
30 synthetic oligomers.

Figure 4. The DNA fragment coding for amino acids 1 to 153 of the N-terminal domain of human FN was assembled from the 7 pairs of chemically synthesized oligomers shown in
35 Figure 3 as follows:

Oligomers 3/4, 5/6, 7/8 and 9/10, each pair in a separate tube, were annealed and then phosphorylated at the 5' end using T4 polynucleotide kinase enzyme.

5 In the second step, pairs 3/4 and 5/6 were ligated to each other using T4 DNA ligase. Similarly, reaction pairs 7/8 and 9/10 were ligated to each other. After each step of ligation an aliquot of the ligation mixture was analyzed on gel to determine the size of the newly formed fragments and
10 the efficiency of ligation.

In the third step, the two above mentioned ligation mixtures were mixed together and pair 6, oligomers 11/12 which had been annealed and phosphorylated previously in a separate
15 tube were added to the mixture. A 326 base pair DNA fragment obtained from the above ligation mixture was isolated from an agarose gel and purified.

The purified synthetic 326 fragment was added to two
20 additional pairs of synthetic linkers: Pair 1, oligomers 1/2 and Pair 7 oligomers 13/14. In Pair 1 only oligomer 2 was phosphorylated at the 5' end and in Pair 7 only oligomer 13 was phosphorylated at the 5' end.

25 After ligation with T4 DNA ligase the mixture without any further isolation was added to pBR322 vector DNA digested with EcoRI and BamHI endonucleases.

The plasmid obtained, designated pFN 932-18 contained the
30 entire synthetic EcoRI (5' end) - BamHI (3' end) restriction fragment coding for the N-terminal 153 amino acids of human FN, in a pBR322 vector.

Figure 5. Expression of the N-terminal 153 amino acid
35 sequence of FN.

Plasmid pFN 932-18 was digested with NdeI and BamHI endonucleases. The NdeI-BamHI DNA fragment coding for FN (first 153 amino acids + additional N-terminal methionine) was isolated and ligated into the large fragment obtained by digestion of plasmid pTV301 with NdeI and BglII endonucleases. (Plasmid pTV301 expresses human growth hormone, hGH, under the control of λ P_L promoter and the cII RBS).

10 The plasmid obtained was designated pFN949-2.

Figure 6. Insertion of termination codon TAA at the 3' end of the N-terminal domain of FN (at amino acid 262)

15

A synthetic oligonucleotide containing a TAA termination codon and a BglII site having the following sequence:

20

CTGTTTAAGCA
GACAAATTCGTCTAG

was ligated to the 3' end (PvuII site) of an EcoRI-PvuII FN fragment isolated from cDNA plasmid p931-5 (see Figure 6) digested with EcoRI and PvuII. The ligation was carried out in the presence of DNA vector plasmid pBR322 digested with EcoRI and BamHI (large fragment). The plasmid obtained was designated pFN935-12.

Figure 7. Comparison of the pharmacokinetics of fibronectin (FN) and r31 kD FBD in rats

30

¹²⁵I-FN (0.1 mg/kg; 5 x 10⁶ cpm) or ¹²⁵I-r31 FBD (0.1 mg/kg; 5 x 10⁶ cpm) were injected intravenously and at the time indicated blood samples were withdrawn. Insoluble radioactivity in the blood samples was determined by trichloroacetic acid precipitation; at zero time, the 100%

35

value represents 40,000 cpm/ml for FN and 46,000 cpm/ml for FBD.

Figure 8. Binding of S. aureus to Catheters

5

Binding of 3.0×10^6 PFU/ml of ^{125}I -S. aureus (1 CPM/3 PFU) to "Uno" bronchial plastic catheters (3 cm for each reaction, in duplicate) coated with FN was carried out as described in methods. When competition reactions were performed, the bacteria and the added protein were pre-
10 incubated at room temperature for 30 minutes and then added to the catheters for further incubation as described in the methods section.

15 The polypeptides used in the competition reactions were: P-31 (p31 kD), r-20 (recombinant 20 kD FBD polypeptide fragment) and r-31 (reoxidized and refolded r31kD). Some of the reactions (see figure) were measured in the presence of 5 μM Heparin (from porcine intestinal mucosa, molecular
20 weight - 10,000; Sigma).

The binding of the "control" reaction in the absence of competitors (8.8% of input bacteria) was normalized to 100%.

25

Figure 9. Recombinant polypeptides of fibronectin domains compared to full-length fibronectin

This figure shows the alignment of cDNA clones encoding
30 various recombinant polypeptides relative to one another and to the full-length sequence of fibronectin cDNA and to a schematic representation of the various domains present within the human fibronectin molecule.

35 Figure 10. Construction of plasmid pFN 196-2 which expresses the r12 kD FBD polypeptide

The large BspMI-HindIII fragment obtained by digestion of plasmid pFN 975-25 (Figure 10) with BspMI and HindIII was ligated by T4 DNA ligase to the synthetic pair of linkers A (see Figure 15). Plasmid pFN 196-2 was produced, transformed into Escherichia coli strain A1645 and retransformed into Escherichia coli strain A4255. Plasmid pFN 196-2 contains the 5'-terminal sequence of fibronectin cDNA from nucleotide 14 to nucleotide 340, i.e., it encodes the first 109 amino acids of the FBD of fibronectin terminating with an arginine residue. An additional N-terminal methionine is present in the final polypeptide. Plasmid pFN 196-2 gives good expression of an r12 kD FBD polypeptide under the control of the λ promoter and β -lactamase ribosomal binding site, and has been deposited in the ATCC under Accession No. 68328.

Figure 11. Construction of plasmid pFN 197-10, which expresses a modified 12 kD FBD polypeptide (12 kD')

Plasmid pFN 975-25 was treated as described in Figure 10 except that a different pair of linkers, B (see Figure 15) was used. The ligation produced plasmid pFN 197-10 which encodes the N-terminal sequence of the FBD of FN; however, a modification after nucleotide 340 to produce an NdeI site (CATATG) before the stop codon results in the encoding of a polypeptide containing 111 amino acids where the first 109 amino acids correspond to those of the r12 kD polypeptide followed by two additional amino acid residues, viz. histidine and methionine. An additional N-terminal methionine residue is present in the final polypeptide. Plasmid pFN 197-10 was transformed into Escherichia coli strain A1645 and hence into Escherichia coli strain A4255, and gave good expression of a modified r12 kD (12 kD') FBD polypeptide under the control of the λ promoter and the β -lactamase ribosomal binding site.

Figure 12. Construction of plasmid pFN 202-5 which expresses r12 kD' FBD fused to the r33 kD cell binding domain (CBD) of fibronectin

5 The large fragment produced after NdeI and HindIII digestion of plasmid pFN 197-10 (Figure 11) was ligated by T4 DNA ligase to the NdeI-HindIII CBD (cell binding domain) fragment of plasmid pFN 137-2. Plasmid pFN 137-2, deposited in the ATCC under Accession No. 67910 has been described in
10 the parent patent application, U.S. Serial No. 345,952; the r33 kD CBD sequence contains amino acids numbered 1329-1722 of fibronectin (see Figure 2) excluding the 90 amino acids numbered 1600-1689 encoded by the ED-A region (see preface to Brief Description of the Figures).

15

The resulting plasmid, pFN 202-5, was transformed into Escherichia coli strain A1645 and thence to Escherichia coli strain A4255. Plasmid pFN 202-5 contains the cDNA sequence of the 111 amino acids encoded by plasmid pFN 197-10
20 followed by the cDNA sequence for r33 kD CBD commencing with the codon for serine (the first amino acid of the r33 kD CBD). This plasmid gave good expression of an approximately 45 kD polypeptide comprising the r12 kD fibrin binding domain and the 33 kD cell binding domain of fibronectin;
25 this fused polypeptide was expressed under the control of the λ promoter and the β -lactamase ribosomal binding site.

Figure 13. Construction of plasmid pFN 195-4 which expresses the r31 kD FBD fused to the sequence DGRGDS

30

The large fragment obtained by digestion of plasmid pFN 975-25 with PvuII and HindIII was isolated and ligated with T4 DNA ligase to a pair of synthetic linkers, C (see Figure
35 15). The resulting plasmid, designated pFN 195-4 was transformed into Escherichia coli strain A1645 and thence to

Escherichia coli strain A4255. Plasmid pFN 195-4 contains the full-length FBD cDNA sequence from nucleotide 14 to nucleotide 793 (encoding 260 amino acids) followed by a sequence encoding asp-gly-arg-gly-asp-ser, i.e., the polypeptide encoded has a total of 260 amino acids followed by the sequence DGRGDS. An additional N-terminal methionine residue is present in the final polypeptide. Plasmid pFN 195-4 is a good expressor of the r31 kD fibrin binding domain fused to the sequence asp-gly-arg-gly-asp-ser (DGRGDS), under the control of the λ promoter and the β -lactamase ribosomal binding site.

Figure 14. Construction of plasmid pFN 194-2 which expresses a fused 31 kD FBD-33 kD CBD polypeptide

The large PvuII-HindIII fragment produced by digestion of plasmid pFN 975-25 with PvuII and HindIII was isolated and ligated with T4 DNA ligase to a pair of linkers, D (Figure 15) and then ligated to the cell binding domain (CBD) fragment obtained by digestion of plasmid pFN 137-2 (ATCC Accession No. 67910) with NdeI and HindIII; see Figure 12 for definition of the CBD domain. The resulting plasmid, designated pFN 194-2, was transformed to Escherichia coli strain A1645 and thence to Escherichia coli strain A4255. Plasmid pFN 194-2 is a low expressor of a fused r31 kD FBD-r33 kD CBD polypeptide of approximate molecular weight 64 kD, under the control of the λ P_L promoter and the β -lactamase ribosomal binding site. The polypeptide encoded by plasmid pFN 194-2 contains DNA encoding the first 265 amino acids of fibronectin fused to a methionine codon, followed by the cDNA sequence for the CBD of fibronectin, commencing at the codon for amino acid serine at position 1 of the CBD.

One skilled in the art knows how to achieve high expression of the polypeptide expressed by plasmid pFN 194-2. An

example of such a high expressor is plasmid pFN 205-5 described in Figure 25.

Figure 15. Oligonucleotide linkers used in construction of plasmids

5

Four pairs of chemically synthesized oligomers (A, B, C and D) were prepared and were used to construct plasmids as described in Figures 10, 11, 13 and 14, respectively).

10 Figure 16. Uptake of labeled r31 kD FBD by stainless steel coil-induced venous thrombi

15 The bars and vertical brackets represent the mean \pm SEM (N=10) of the specific radioactivity associated with isolated thrombi, vein segments carrying the thrombus ("thrombi in-situ"), or peripheral blood samples 24h after administration of ^{125}I -31 kD FBD. For details, see Example 7, Section A.

20 Figure 17. Comparison of labeled r12 kD, r20 kD and r31 kD FBD polypeptides in the rat venous thrombus model

25 The bars and vertical brackets represent the mean \pm SEM (N=5) of the specific radioactivity associated with isolated thrombi (T) or blood (B) 24 hours after administration of the ^{125}I -labeled recombinant polypeptides, as indicated. For details, see Example 7, Section B.

30 Figure 18. Metabolic stability of ^{125}I -labeled r31 kD FBD in rats

35 Rats were injected intravenously with ^{125}I -r31 kD FBD (5×10^6 cpm/rat) in a similar experiment to that described in Figure 7. At the time intervals indicated blood samples were removed, placed in sodium citrate-containing tubes

(final sodium-citrate concentration = 0.38%) and resulting blood aliquots were directed as follows: either (a) treated with 20% TCA and the TCA insoluble counts (after TCA precipitation) were measured; or (b) incubated with preformed clot (using 20 μ l whole blood from control rat); binding of the 125 I-31 kD FBD to the preformed clot was measured under the conditions of the two-step reaction II (Example 6). The radioactivity was measured by a gamma counter and the activity of each sample was calculated as a percentage of total cpm present in the reaction mixture. (Normally TCA precipitation includes placing sample aliquots on filters which are counted for total cpm, washing the filter 3 times with 20% TCA followed by twice with 20% ethanol to extract the TCA, and recounting filters for TCA insoluble counts whereby the percentage of TCA-insoluble counts can be calculated.)

Figure 19. Binding of fibrin binding domain polypeptides to the fibrin clot

This experiment was carried out essentially as described for the two-step Reaction II (Example 6). 0.15 μ M 125 I of one of the fibrin binding domain polypeptides as indicated below was incubated at 37°C with preformed fibrin clot derived from 20 μ l citrated whole blood. The binding was measured in the presence of 5 mM CaCl₂ and 0.02 units/ml transglutaminase. The reaction was terminated, after a 45 minute incubation, by centrifugation; the pellet was washed three times with PBS and the radioactivity was measured in a gamma counter.

1. plasmatic 31 kD FBD (p31 kD)
2. r12 kD
3. r20 kD
4. r31 kD (Batch A)
5. r31 kD (Batch B)
6. r31 kD (Batch C)

Figure 20. Comparison of binding of ^{125}I -r12 kD to fresh and frozen fibrin clots

10

This experiment was carried out essentially as described for the two-step Reaction II (Example 6). Preformed fibrin clots derived from 20 μl citrated whole human blood were either frozen at -70°C for 7 days (frozen clots) or used immediately after their formation (fresh clots).

15

The fibrin clots were incubated with $0.15 \mu\text{M}$ ^{125}I -r12 kD in the presence or absence of 0.02 units/ml guinea-pig liver transglutaminase (Sigma). The binding to fibrin clots was measured as described in Example 6.

20

Figure 21. Refolding and purification of the r20 kD polypeptide as monitored by elution profiles from a Superose 12 column (attached to a FPLC)

25

Aliquots of 200 μl of the r20 kD polypeptide at various stages of the refolding and purification process were injected on top of a Superose 12 column (attached to a FPLC). The column was equilibrated and eluted with a solution of 150 mM NaCl/20 mM Tris HCl, pH 7.8, at a flow rate of 0.8 ml/min. The lower trace is obtained from the FPLC Controller LCC-500. A. Pellet of r20 kD polypeptide solubilized in 6 M Guanidine-HCl and reduced with 50 mM β -mercaptoethanol; B. Refolded and air-reoxidized r20 kD polypeptide; C. Q-Sepharose bound polypeptides, i.e.,

30

35

material which was separated from the purified r20 kD; D. Flow-through from the Q-Sepharose column; E. Flow-through from the Heparin-Sepharose column, i.e., material which was separated from the purified r20 kD; F. Purified 20 kD polypeptide (retention time = 18.16 min), eluted from the Heparin-Sepharose column with 0.5 M NaCl. Note that there is no peak at this retention time of 18.16 min in Profile A, where the material is in reduced form, nor in Profiles C & E, which contain incorrectly folded forms of the 20 kD polypeptide.

Figure 22. Refolding and purification of the r12 kD polypeptide as monitored by elution profiles from a Superose 12 column (attached to a Waters HPLC system)

Aliquots of 25-100 μ l of the r12 kD polypeptide at various stages of the refolding and purification process were injected on top of a Superose 12 column (attached to a Waters HPLC system). The column was equilibrated and eluted with a solution of 150 mM NaCl/20 mM Tris HCl, pH 7.8, at a flow rate of 0.8 ml/min. A. Pellet of r12 kD polypeptide solubilized in 6 M Guanidine-HCl and reduced with 50 mM β -mercaptoethanol; B. Refolded and air-reoxidized r12 kD polypeptide; C. Q-Sepharose bound polypeptides, i.e., material which was separated from the purified r12 kD; D. Flow-through from both the Q- and Heparin-Sepharose columns (in this case, the columns were connected in series and the flow-through from the Q-Sepharose was therefore automatically loaded on the Heparin-Sepharose column), i.e., material which was separated from the purified r12 kD; E. Purified r12 kD polypeptide (retention time - 18.83 min), eluted from the Heparin-Sepharose column with 0.5 M NaCl. Note that there is no peak at this retention time of 18.83 min in Profile A, where the material is in reduced form, nor

in Profiles C & D, which contain incorrectly folded forms of the r12 kD polypeptide.

Figure 23. Construction of Plasmid pFN 208-13

5

Two aliquots of plasmid pFN 975-25 (ATCC No. 67832) were separately digested with XmnI and XbaI-StyI respectively. The large fragments were isolated from each digest and mixed together with the synthetic oligomer shown in Figure 8. The mixture was then boiled for 2.5 minutes, cooled gradually for 60 minutes at 30°C, followed by 60 minutes at 4°C, and finally 30 minutes at 0°C. The now reannealed DNA was then filled in by Klenow fragment and ligated with T4 DNA ligase. The DNA was transformed into E.coli A1645 and transformants were screened for a clone positive for the oligomer. The plasmid from a positive clone was designated pFN 208-13, and deposited in the ATCC in a host E.coli A4255 as Accession No. 68456. This plasmid expresses an 18.5 kD FBD polypeptide of the amino terminal end of the molecule under control of the λ P_L promoter and the β -lactamase ribosomal binding site.

10
15
20

Figure 24. Synthetic Linker Used in Construction of Plasmid pFN 208-13

25

This figure shows the synthetic oligomer used in construction of plasmid pFN 208-13 (Figure 23)

Figure 25. Construction of Plasmid pFN 205-5

30

The small fragment was isolated from the digestion of plasmid pFN 194-2 (Figure 14) by XbaI-HindIII. The small fragment was isolated from NdeI-HindIII digestion of plasmid pFN 962-3 (disclosed in coassigned patent application PCT/US89/05875 and published as international publication no. WO/90/07577 on July 12, 1990, Figures 45-49 and the

35

description of the figures). These two fragments were then ligated with the large fragment isolated from the NdeI-HindIII digest of plasmid pMLK-100 (ATCC Accession No. 68605). The resulting plasmid designated 205-5 is a high
5 expressor of a 64 kD polypeptide containing the 31 kD FBD fused to the 33 kD CBD under control of the λP_L promoter, CII ribosomal binding site and containing the trp transcription terminator designated "ter" immediately downstream of the structural gene. This polypeptide has
10 been purified and refolded essentially as described for a 31 kD FBD polypeptide disclosed in the above-referenced PCT publication.

Figure 26. Construction of Plasmid pFN 201-3

15

The large fragment was isolated from the HindIII-StyI digest of plasmid pFN 949-2 (ATCC Accession No. 67831), and ligated with the small fragment isolated from the HindIII-StyI digest of plasmid pFN 196-2 (ATCC Accession No. 68328). The
20 resulting plasmid designated pFN 201-3 expresses the 12 kD FBD polypeptide under control of the λP_L promoter and CII ribosomal binding site.

Figure 27. Construction of Plasmid pFN 203-2

25

The large fragment was isolated from the NdeI-HindIII digest of plasmid pMLK-100 (deposited in E.coli 4300 under ATCC Accession No. 68605) and ligated with the small fragment isolated from the NdeI-HindIII digest of plasmid pFN 201-3.
30 The resulting plasmid designated pFN 203-2 which expresses the 12 kD FBD polypeptide under control of the λP_L promoter, C_{II} ribosomal binding site and trp transcription termination sequence designated "ter" was deposited in ATCC in E.coli A4255 under ATCC Accession No. 68606. Plasmid pFN
35 203-2 is also known as pFN 203-2-3.

Figure 28. Binding of FBD Polypeptide Fragments to Vascular Components

5 This figure shows the low degree of binding of the 12 kD polypeptide to vascular components such as endothelial cells, extracellular matrix, and immobilized fibronectin by comparison with the 31 kD as described in Example 9. The binding of the 12 kD was increased but still remained relatively low in comparison to the 31 kD even with the
10 addition of exogenous transglutaminase.

Figure 29. Effect of Various FBD Polypeptide Fragments on the Binding of S.aureus to Endothelial Cells (EC)

15 Preparation of labelled S. aureus and the endothelial cell (EC) binding assay are described in Example 9. The inhibitory effect of plasmatic and recombinant 31 kD, recombinant 18.5 kD, and recombinant 12 kD on binding of S.
20 aureus to EC were tested.

This figure shows the dose effect of different FBD polypeptides on binding of S. aureus to endothelial cells at 4°C in the presence or absence of fetal calf serum (FCS).
25 (Previous experiments showed a dramatic increase of 2-3 fold in binding of S. aureus to EC in the presence of FCS at 37°C, but only a slight increase at 4°C. The increase is probably due to the presence of plasma fibronectin in FCS.) In the present experiment performed at 4°C, there is no
30 significant effect of added FCS on the binding. Both the plasmatic and recombinant 31 kD show a strong dose dependent inhibition of binding, while the recombinant 18.5 kD and 12 kD polypeptide fragments caused virtually no inhibition of binding indicating they have little or no S.aureus binding
35 affinity.

Figure 30. Binding of Different FBD Polypeptide Fragments to Preformed Fibrin Clot (Reaction II)

5 This figure shows the specificity of different FBD polypeptides to a preformed fibrin clot as described in Example 9. The FBD polypeptides tested were the 31 kD, 20 kD, 18.5 kD and 12 kD. Additionally, a 45 kD fusion polypeptide of the 12 kD FBD fragment fused to the 33 kD CBD
10 (Example 40) was tested. A 33 kD CBD polypeptide (coassigned PCT Publication No. WO/90/07577, pages 62-64) was included as a control. All of the FBD polypeptides tested, including the 45 kD fusion polypeptide, bound to a preformed fibrin clot in similar proportions (25-38% bound).
15 The 33 kD CBD alone bound to the clot in a small proportion only. The transglutaminase inhibitor iodoacetate (IAC) inhibited binding by 50-75% indicating that transglutaminase is an active component of the binding reaction. The binding of the 33 kD CBD polypeptide was not appreciably affected by
20 iodoacetate indicating that it binds by a different mechanism.

Figure 31. In vivo thrombi labeling using the 12 kD and 18.5 kD FBD polypeptide fragments is described in Example
25 13. The figure shows the results as specific radioactivity of thrombus (hatched bars) and blood (open bars) of stainless-steel coil-bearing rats, 24h after intravenous administration of ¹¹¹In-labelled recombinant FBD proteins. The bars and vertical brackets represent the means and SEM
30 of cpm/g wet weight, respectively. The thrombus: blood ratios are shown in Figure 32.

Figure 32. Thrombus to blood ratios of specific radioactivity 24h after administration of ¹¹¹In-labelled 12
35 kD-, 18.5 kD- and 31 kD-FBD in the rat coil model described in Fig. 31.

Figure 33. Lineweaver-Burke plots for human Glu-Plasminogen activation kinetics, at pH 7.4 and 37°C, using either SK or the FBD-SK complex as activators. In a 200 µl volume, in 96-well plates, the plasminogen substrate concentration varied
5 between 0.9×10^{-6} and 2.7×10^{-6} M. The S-2251 substrate (H-D-Val-Leu-Lys-pNA) final concentration was 5×10^{-4} M and the final activator concentration was 2×10^{-9} M. The rate of reaction, v , represents the change in absorbance at 405nm, ΔA (absorbance units), per time Δt (min).

10

Figure 34. Fibrin-agar plates were prepared by mixing 5 ml (2mg/ml) fibrinogen, 5 ml (0.4%) Noble-agar, 0.5 ml (1M) CaCl_2 and 0.5 ml (10u/ml) thrombin, all in imidazole-buffered saline pH 7.4. After polymerization small wells
15 were made using Pasteur pipettes and vacuum, into which aliquots of SK or FBD-SK complex, at concentrations between 10^2 - 10^4 ng/ml, were added. After incubation at 37°C overnight the lysis zone was measured.

20

Figure 35. Guinea Pig Transglutaminase Catalyzed Incorporation of [^{14}C] Putrescine into FBD or the FBD-SK Complex.

25 Assays were performed up to 30 min at room temperature with 6 µM FBD SK, or FBD-SK complex, 0.05u/ml transglutaminase, 6 µM [^{14}C] putrescine, 6 µM cold putrescine, 50 mM Tris HCl pH 7.5 and 10 mM CaCl_2 . Controls with 20 mM EDTA (dotted line) or 5 mM DTT (dashed line) were also included. (Δ) SK,
30 (◻) FBD, (◻) FBD-SK complex.

Detailed Description of the Invention

The plasmids pFN 975-25, pFN 949-2, pFN 137-2, and pFN 196-2 were deposited pursuant to, and in satisfaction of, the requirements of the Budapest Treaty on the International Recognition of the Deposit of Microorganisms for the Purposes of Patent Procedure with the American Type Culture Collection (ATCC), 12301 Parklawn Drive, Rockville, Maryland 20852 under ATCC Accession Nos. 67832, 67831, 67910 and 68328, respectively. ATCC 67832 and ATCC 67831 were deposited on 26th October, 1988, ATCC 67910 was deposited on 10th March, 1989 and ATCC 68328 was deposited on 16th May, 1990. The following E. coli strains were also deposited with the American Type Culture Collection:

15	Strain	Accession No.	Deposit Date
	<u>E. coli</u> pTV 104(2)	39384	29 June, 1983
	<u>E. coli</u> pSOD alpha 2	39786	2 August, 1984
	<u>E. coli</u> pBLA 11	39788	2 August, 1984
	<u>E. coli</u> A3111	53217	6 August, 1985
20	<u>E. coli</u> A4346	53218	6 August, 1985
	<u>E. coli</u> pJBF5401/ <u>E. coli</u> S ϕ 540	67359	20 March, 1987
	<u>E. coli</u> p18UL-1/ <u>E. coli</u> MC1061	67361	20 March, 1987
25	<u>E. coli</u> pMF 2005/ <u>E. coli</u> S ϕ 732	67362	20 March, 1987
	<u>E. coli</u> S phi 930(F ⁻)/ pMF 5534	67703	23 May, 1988
	<u>E. coli</u> W3110(F ⁻)/pMFS 929	67705	23 May, 1988
30	<u>E. coli</u> S phi 930/pEFF 920	67706	23 May, 1988
	<u>E. coli</u> A4255, pFN 208-13	68456	1 November, 1990
	<u>E. coli</u> 4300/pMLK 100	68605	16 April, 1991
	<u>E. coli</u> pFN 203-2	68606	16 April, 1991

35 The primary sequence of human fibronectin has been shown to be organised in three types of homologous repeats, Types I, II, and III. The fibrin-binding domain (FBD), comprised of 259 amino acids with an apparent molecular weight of 31 kD, is made up of five type I repeats ("fingers"), each about 45



amino acids long with two disulfide bonds, connected to two stretches of about 20 amino acids each at both the N- and C-terminal ends of the protein.

- 5 An overall schematic view of the structure of the domains of fibrinectin and the recombinant molecules constructed is shown in Figure 1.

The recombinant fibrin binding domain (FBD) polypeptides
10 claimed herein comprise polypeptide fragments of the fibrin binding domain (r20 kD, r18.5 kD and r12 kD polypeptides). These polypeptides are smaller than the 31 kD polypeptide and comprise part of the sequence of the fibrin binding domain. Many other polypeptides of the fibrin binding domain may be
15 expressed by additional plasmids constructed, using methods known in the art, from plasmids described in this application and these polypeptides may be refolded,



reoxidized, and purified using methods described in this application.

5 The full length recombinant fibrin binding domain (the r31 kD polypeptide) described in this application comprises the first 262 amino acids of fibronectin with the sequence arg-ala-ala-val at the carboxy-terminus. An additional methionine residue is present at the amino terminus of all the final polypeptides and polypeptide fragments of the FBD.

10 The plasmatic fibrin binding domain derived by tryptic digestion of plasma fibronectin comprises the first 259 amino acids of fibronectin, i.e. with arginine at the carboxy-terminus and the first encoded amino acid, glutamine, converted to a pyroglutamate residue.

15

The r31 kD polypeptide has five of the Type I homology loops or fingers discussed above (i.e. 10 disulfide bonds), the r20 kD polypeptide and r18.5 kD polypeptide both have three loops (i.e. 6 disulfide bonds), and the r12 kD polypeptide

20 has two loops (i.e. 4 disulfide bonds). The presence of these disulfide bonds explains the necessity and also the difficulty of the refolding/reoxidation procedure developed to obtain and purify correctly folded FBD polypeptides which have the correct disulfide bonds. The correctly folded FBD

25 polypeptides are biologically active, i.e. they can bind to fibrin; additionally, the r31 kD polypeptide can bind to Staphylococcus aureus.

30 The recombinant FBD polypeptides are produced in inclusion bodies which are obtained in the pellet produced after disruption of the cell cake.

This invention discloses the production of recombinant polypeptide fragments of the fibronectin fibrin binding

35 domain (FBD) for use in thrombus imaging and prevention of

thrombus formation. These polypeptides may also be bound to a thrombolytic agent for targeting the agent to a thrombus.

5 The recombinant cells which produce the polypeptide fragments of the FBD can be any cells in which a DNA sequence encoding an FBD polypeptide fragment has been introduced by recombinant DNA techniques. The cell must be capable of expressing the DNA sequence and producing the polypeptide product. The cell may be a mammalian cell, a
10 fungal cell such as a yeast cell, or a bacterial cell.

The bacterial cell can be any strain including auxotrophic, prototrophic and lytic strains, F⁺ and F⁻ strains, strains harboring the cI857 repressor sequence of the λ prophage and
15 strains deleted for the deo repressors or the deo gene.

Examples of wild type Escherichia coli strains are prototroph ATCC No. 12435, and auxotroph MC1061 (ATCC Accession No. 67361).
20

Examples of Escherichia coli strains which harbor the λ cI857 repressor sequence are the auxotrophs A1645 harboring plasmid pTVR 279-8 (ATCC No. 53216), A1637 harboring plasmid pTV 104(2) (ATCC No. 39384), and A2097 harboring plasmid
25 pSOD α 2 (ATCC No. 39786), and the prototrophs A4255 harboring plasmid pFN 975-25 (ATCC No. 67832) and biotin-independent A4346 harboring plasmid pHG44 (ATCC No. 53218).

An example of a lytic Escherichia coli strain is A4048 which
30 harbors plasmid pHG44 (ATCC No. 53217).

Examples of F⁻ strains are Escherichia coli S ϕ 930 (F⁻) harboring plasmid pMF 5534 deposited under ATCC No. 67703 and Escherichia coli W31100 (F⁻) harboring plasmid pMFS 929
35 deposited under ATCC No. 67705.

Examples of Escherichia coli strains deleted for the deo gene or deo repressors are S ϕ 732 harboring plasmid pMF 2005 (ATCC No. 67362), S ϕ 540 harboring plasmid pJBF 5401 (ATCC No. 67359), and S ϕ 930 harboring plasmid pEFF 920 (ATCC No. 67706) (see European Patent Application Publication No. 0303972, published February 22, 1989).

The plasmids of this invention may be introduced into suitable bacterial host cells, preferably Escherichia coli. An example of a suitable Escherichia coli cell is strain A4255 (F⁺) [ATCC Accession No. 67832], but other Escherichia coli strains and other bacteria can also be used as host cells for the plasmids. Such bacteria include Pseudomonas aeruginosa and Bacillus subtilis.

All of the Escherichia coli host strains described above can be "cured" of the plasmids they harbor by methods well known in the art, e.g. the ethidium bromide methods described by R.P. Novick in Bacteriol. Rev. 33: 210 (1969).

The bacterial cell may contain the FBD sequence encoding the FBD polypeptide in the body of a vector DNA molecule such as a plasmid. The vector or plasmid is constructed by recombinant DNA techniques so that the sequence encoding the FBD polypeptide is incorporated at a suitable position in the molecule.

Plasmids used for production of the FBD polypeptides can harbor a variety of promoters such as the λ promoter or the deo promoters.

Among the plasmids which may be used for production of FBD polypeptides are the following:

- a) Plasmid pFN 975-25 which expresses the r31 kD FBD and which has been deposited in Escherichia coli strain A4255 in the ATCC under Accession No. 67832;
- 5 b) Plasmid pFN 949-2 which expresses the r20 kD FBD and which has been deposited in Escherichia coli strain A4255 in the ATCC under Accession No. 67831;
- 10 c) Plasmid pFN 196-2 which expresses the r12 kD FBD and which has been deposited in Escherichia coli strain A4255 in the ATCC under Accession No. 68328;
- 15 d) Plasmid pFN 197-10 which expresses a modified 12 kD FBD polypeptide, and which has been described in Figure 11 of this application;
- 20 e) Plasmid pFN 195-4 which expresses the r31 kD polypeptide fused to the sequence DGRGDS, and which has been described in Figure 13 of this application;
- 25 f) Plasmid pFN 201-3 which expresses a 12 kD FBD polypeptide fragment under control of λP_L and the C_{II} rbs, and which has been described in Figure 26 of this application.
- 30 g) Plasmid pFN 203-2 which expresses a 12 kD FBD polypeptide fragment under control of λP_L and the C_{II} rbs, and additionally contains a transcription terminator designated "ter," and which has been described in Figure 27 of this application and which has been deposited in Escherichia coli A4255 in ATCC under Accession No. 68606.
- 35 h) Plasmid pFN 205-5 which expresses a 64 kD polypeptide comprising a 31 kD full-length FBD polypeptide fused to a 33 kD fragment of the fibronectin cell-binding domain

(CBD) and which has been described in Figure 25 of this application.

- 5 i) Plasmid pFN 208-13 which expresses an 18.5 kD FBD polypeptide fragment which has been described in Figure 23 of this application and has been deposited in Escherichia coli A4255 in ATCC under Accession No. 68456.
- 10 j) Any plasmid, derived from the above plasmids, containing FBD sequences encoded by the above plasmids; and
- 15 k) Any plasmid which contains FBD sequences encoded by the above plasmids.

The subject invention provides an imaging agent which comprises a polypeptide labeled with an imageable marker, such polypeptide having an amino acid sequence substantially present in the fibrin binding domain of naturally-occurring human fibronectin and being capable of binding to fibrin. Also provided is a composition comprising an effective imaging amount of such an imaging agent and a physiologically acceptable carrier.

25 The polypeptides which are labeled with an imageable marker may be polypeptide fragments of the fibrin binding domain of human fibronectin; they may be produced using recombinant DNA techniques; or encoded by genes synthesized in a DNA synthesizer. Applicants have provided three examples of such polypeptides, with the preferred embodiments being the 18.5 kD and 12 kD polypeptides. As would be understood by one skilled in the art, the terms "having an amino acid sequence substantially present in the fibrin binding domain of naturally-occurring human fibronectin" encompasses, i.e., 35 naturally-occurring allelic variations and recombinant

variations, such as site-directed mutagenesis. These are all encompassed by applicants' "polypeptide," the only limitation being the ability to bind to fibrin.

- 5 The imageable marker used is a matter of choice to one skilled in the art. It is preferred that the marker be a radioactive isotope, an element which is opaque to X-rays, or a paramagnetic ion.
- 10 Radioactive isotopes are commonly used in medicine and are well known to those skilled in the art. It is presently preferred that the marker be indium-111, technetium-99m, iodine-123, iodine-125, iodine-131, krypton-81m, xenon-133, or gallium-67, or mixtures thereof. Most preferably, the
- 15 marker is technetium-99m or indium-111.

The detectable marker may also be a paramagnetic ion. Paramagnetic ions are also commonly used in medicine. Examples of such markers include chelated metal ions of

20 chromium (III), manganese (II), iron (III), iron (II), cobalt (II), nickel (II), copper (II), praseodymium (III), neodymium (III), samarium (III), gadolinium (III), terbium (III), dysprosium (III), holmium (III), erbium (III), ytterbium (III), or mixtures thereof.

- 25 Preferably, the imaging agent comprises a 20 kD polypeptide corresponding to an amino acid sequence present in the fibrin binding domain of human fibronectin and having the amino acid sequence of amino acids 1-153 as shown in Figure
- 30 2 and about 20 additional amino acids; or an 18.5 kD polypeptide corresponding to an amino acid sequence present in the fibrin binding domain of human fibronectin and having the amino acid sequence of amino acids 1-154 as shown in Figure 2; or a 12 kD polypeptide corresponding to an amino
- 35 acid sequence present in the fibrin binding domain of human fibronectin and having the amino acid sequence of amino

acids 1-109 as shown in Figure 2. By means of partial amino acid sequence analysis we have shown that the 12 kD and 20 kD as well as the previously disclosed 31 kD polypeptides all contain an additional N-terminal methionine. Since all
5 the polypeptide fragments of the FBD have identical N-terminal sequences it may be assumed that the 18.5 kD, 45 kD and 64 kD polypeptides also have the additional N-terminal methionine. However, the invention claimed herein also includes the polypeptides without the additional N-terminal
10 methionine.

The subject invention also provides a method for imaging a fibrin-containing substance, i.e. a thrombus or atherosclerotic plaque, which comprises contacting the
15 fibrin-containing substance to be imaged with the agent as disclosed above under conditions such that the agent binds to the fibrin-containing substance and imaging bound agent and thereby imaging the fibrin-containing substance.

20 Further provided is a method for imaging a fibrin-containing substance in a subject which comprises:

- (a) administering to the subject a composition of the agent as disclosed above under conditions
25 permitting the imaging agent therein to enter the blood stream and bind to fibrin present in the blood vessels;
- (b) imaging bound agent within the blood vessels; and
30 thereby
- (c) imaging the fibrin-containing substance.

Preferably, the polypeptide of the reagent used in the above
35 methods for imaging a fibrin-containing substance is a 20 kD polypeptide corresponding to an amino acid sequence present

in the fibrin binding domain of human fibronectin and having the amino acid sequence of amino acids 1-153 as shown in Figure 2; the 20 kD polypeptide comprising less than about 20 additional amino acids; an 18.5 kD polypeptide
5 corresponding to an amino acid sequence present in the fibrin binding domain of human fibronectin and having the amino acid sequence of amino acids 1-154 as shown in Figure 2; or a 12 kD polypeptide corresponding to an amino acid sequence present in the fibrin binding domain of human
10 fibronectin and having the amino acid sequence of amino acids 1-109 as shown in Figure 2.

Preferred markers used in the above methods for imaging a fibrin-containing substance are radioactive isotopes,
15 elements which are opaque to X-rays, or paramagnetic ions. Most preferred markers are radioactive isotopes, such as indium-111, technetium-99m, iodine-123, iodine-125, iodine-131, krypton-81m, xenon-133, and gallium-67.

20 Imaging may be done through any of the methods known to one skilled in the art. These methods include but are not limited to X-ray, CAT scan, PET scan, NMRI, and fluoroscopy. Preferably, the imaging of the fibrin-containing substance by the above methods is carried out using a gamma camera.

25 Further provided is a plasmid for expression of a polypeptide having an amino acid sequence substantially present in the fibrin binding domain of naturally-occurring human fibronectin and being capable of binding to fibrin
30 comprising DNA encoding the polypeptide and DNA encoding suitable regulatory elements positioned relative to the DNA encoding the polypeptide so as to effect expression of the polypeptide in a suitable host cell.

35 Applicants have provided three examples of polypeptide fragments of the fibrin binding domain of fibronectin.

These include the r20 kD, r18.5 kD and r12 kD polypeptides. These polypeptides exhibit the binding and adhesive properties of portions of naturally-occurring human fibronectin. The scope of the claims of the subject application are not intended to be limited to these three FBD polypeptide fragments, which are examples of preferred embodiments only.

In preferred embodiments, the polypeptide is about a 20 kD polypeptide corresponding to an amino acid sequence present in the fibrin binding domain of human fibronectin; about an 18.5 kD polypeptide corresponding to an amino acid sequence present in the fibrin binding domain of human fibronectin; or about a 12 kD polypeptide corresponding to an amino acid sequence present in the fibrin binding domain of human fibronectin.

In more preferred embodiments, the polypeptide is an 18.5 kD polypeptide corresponding to an amino acid sequence present in the fibrin binding domain and having the amino acid sequence of amino acids 1-154 as shown in Figure 2, a 20 kD polypeptide corresponding to an amino acid sequence present in the fibrin binding domain of human fibronectin and having the amino acid sequence of amino acids 1-153 as shown in Figure 2; the 20 kD polypeptide comprising less than about 20 additional amino acids; or a 12 kD polypeptide corresponding to an amino acid sequence present in the fibrin binding domain of human fibronectin and having the amino acid sequence of amino acids 1-109 as shown in Figure 2. As noted above, the polypeptides also may have the additional N-terminal methionine. However, the invention claimed herein also includes the polypeptides without the additional N-terminal methionine.

Naturally-occurring human fibronectin is as it occurs in the human body (in plasma).

As used throughout this application, a substantial portion is at least one fifth (1/5). A polypeptide which has the biological activity of the fibrin binding domain of naturally-occurring human fibronectin exhibits binding or adhesive properties similar to those of the fibrin binding domain of naturally-occurring human fibronectin when the level of such activity is assayed or determined.

In this invention, the amino acid sequence of the various functional domains are determined by cleavage of the cDNA which encodes the domains with restriction enzymes, and do not necessarily correspond to the amino acid sequence of the domains as obtained and defined by proteolytic digestion of fibronectin.

The plasmid of this invention further comprises suitable regulatory elements positioned relative to the DNA encoding the polypeptide so as to effect expression of the polypeptide in a suitable host cell, such as promoters and operators, e.g. λ P_LO_L, ribosomal binding sites, e.g. C_{II}, and repressors. Other suitable regulatory elements include, for example, the lac, trp, tac, lpp and deo promoters (European Patent Application Publication No. 0303972, published February 22, 1989).

The suitable regulatory elements are positioned relative to the DNA encoding the polypeptide so as to effect expression of the polypeptide in a suitable bacterial host cell. In preferred embodiments of the invention, the regulatory elements are positioned close to and upstream of the DNA encoding the polypeptide.

Further provided is a plasmid designated pFN 949-2 and deposited in Escherichia coli strain A1645 under ATCC Accession No. 67831. Plasmid pFN 949-2 encodes a 20 kD polypeptide fragment of the fibrin binding domain of human

fibronectin comprising amino acids 1-153 of Figure 2 with an additional N-terminal methionine, and less than 20 additional amino acids.

5 Also provided is a plasmid designated pFN 196-2 and deposited in Escherichia coli strain A4255 under ATCC Accession No. 68328. Plasmid pFN 196-2 encodes a 12 kD polypeptide fragment of the fibrin binding domain of human fibronectin comprising amino acids 1-109.

10

Also provided is a plasmid designated pFN 208-13 deposited in Escherichia coli A4255 under ATCC Accession No. 68456. Plasmid pFN 208-13 encodes an 18.5 kD polypeptide fragment of the fibrin binding domain of human fibronectin comprising amino acids 1-154 of Figure 2 and may be assumed to have an additional N-terminal methionine as described above.

15

Also provided is a plasmid designated pFN 203-2 deposited in Escherichia coli A4255 under ATCC Accession No. 68606. Plasmid pFN 203-2 expresses a 12 kD polypeptide fragment of the fibrin-binding domain of human fibronectin comprising amino acids 1-109 of Figure 2 with an additional N-terminal methionine.

20

25 Also provided is a plasmid designated pFN 205-5 which expresses a 64 kD polypeptide comprising a 31 kD full-length FBD polypeptide fused to a 33 kD fragment of the fibronectin CBD (described in Figure 25).

30

As discussed above, it may be assumed that all of the polypeptides produced by the plasmids of this invention contain an additional N-terminal methionine.

35

In presently preferred embodiments, the invention provides an Escherichia coli cell containing the plasmid designated pFN 975-25 and wherein the cell is deposited under ATCC

Accession No. 67832; an Escherichia coli cell containing the plasmid designated pFN 949-2 and wherein the cell is deposited under ATCC Accession No. 67831; and an Escherichia coli cell containing the plasmid designated pFN 196-2 and wherein the cell is deposited under ATCC Accession No. 68328; an Escherichia coli cell containing the plasmid designated pFN 203-2 and wherein the cell is deposited under ATCC Accession No. 68606; and an Escherichia coli cell containing the plasmid designated pFN 208-13 and wherein the cell is deposited under ATCC Accession No. 68456.

The invention provides a method of producing a polypeptide having an amino acid sequence substantially present in the fibrin binding domain of naturally-occurring human fibronectin and being capable of binding to fibrin which comprises treating a cell containing a plasmid comprising DNA encoding the polypeptide so that the DNA directs expression of the polypeptide and recovering from the cell the polypeptide so expressed.

Preferably, the polypeptide so produced is an 18.5 kD, 20 kD, or 12 kD polypeptide fragment of the fibrin binding domain.

Further provided is a purified polypeptide substantially free of other substances of human origin which has an amino acid sequence substantially present in the fibrin binding domain of naturally-occurring human fibronectin and being capable of binding to fibrin.

Preferably, the polypeptide is a 20 kD polypeptide corresponding to an amino acid sequence present in the fibrin binding domain of human fibronectin and having the amino acid sequence of amino acids 1-153 as shown in Figure 2; the 20 kD polypeptide comprising less than about 20 additional amino acids; or an 18.5 kD polypeptide

corresponding to an amino acid sequence present in the fibrin binding domain of human fibronectin and having the amino acid sequence of amino acids 1-154 as shown in Figure 2; or a 12 kD polypeptide corresponding to an amino acid sequence present in the fibrin binding domain of human fibronectin and having the amino acid sequence of amino acids 1-109 as shown in Figure 2. As noted above, the polypeptides also may have the additional N-terminal methionine. However, the invention claimed herein also includes the polypeptides without the additional N-terminal methionine.

These shorter FBD polypeptide fragments, i.e. 20 kD, 18.5 kD, and 12 kD are advantageous over the 31 kD FBD polypeptide. They are easier to refold, lack the bacterial binding domain, and have a much reduced binding specificity for other vascular components such as endothelial cells, extracellular matrix and fibronectin by comparison to the 31 kD polypeptide, while maintaining a fibrin-binding activity similar to that of the 31 kD polypeptide.

The invention further provides such a purified polypeptide substantially free of other substances of human origin fused to a second polypeptide, the second polypeptide comprising a substantial portion of the amino acid sequence of the cell binding domain of naturally-occurring human fibronectin.

Preferably, the fused polypeptide is a 45 kD fused polypeptide, wherein the purified polypeptide is a 12 kD polypeptide and the second polypeptide which comprises a substantial portion of the cell binding domain of naturally-occurring human fibronectin is a 33 kD polypeptide. The fused polypeptide may also comprise a 31 kD purified polypeptide and a second polypeptide which contains the amino acid sequence DGRGDS. Another preferred fused polypeptide is a 64 kD fused polypeptide, wherein the purified

polypeptide is a 31 kD polypeptide and the second polypeptide which comprises a substantial portion of the cell binding domain of naturally-occurring human fibronectin is a 33 kD polypeptide.

5

The invention also provides a plasmid for expression of the 45 kD fused polypeptide, disclosed above, designated pFN 202-5; a plasmid for expression of the 31 kD/GRGDS fused polypeptide, disclosed above, designated pFN 195-4; and a
10 plasmid for expression of the 64 kD fused polypeptide, disclosed above, designated pFN 194-2.

As used throughout the subject application, "fused" or "bound" encompasses polypeptides bound covalently, non-
15 covalently, or conjugated. The polypeptides may be conjugated through other chemical moieties including amino acid or polypeptide cross-linkers, which are standardly used in the art and are well-known to those skilled in the art to which the subject invention pertains.

20

Numerous methods are known in the art for detection of thrombi, such as radioactive labeling (nuclear medicine use of isotopes), radio-opaque labeling (such as CAT scan), and Magnetic Resonance Imaging (MRI). Any of these labeling
25 methods can be used in the method of the subject invention for detecting the thrombus. In each of these detection methods the polypeptide is used as a diagnostic agent for detecting the thrombus.

Also provided is a method of refolding and reoxidizing a polypeptide having an amino acid sequence substantially present in the fibrin binding domain of naturally-occurring human fibronectin but lacking the disulfide bonds of naturally-occurring human fibronectin and being capable of
30 binding to fibrin which comprises contacting the polypeptide with a thiol-containing compound in the presence or absence
35

of a disulfide so as to refold and reoxidize the polypeptide.

5 Preferably, the thiol-containing compound is selected from the group consisting of glutathione, thioredoxin, β -mercaptoethanol, and cysteine.

10 Preferably, the thiol-containing compound is β -mercaptoethanol and the disulfide is produced in situ by introduction of air.

15 Preferably, the polypeptide is selected from the group consisting of an 18.5 kD polypeptide, a 20 kD polypeptide, a 12 kD polypeptide and a 45 kD polypeptide. The 45 kD chimera polypeptide consisting of the 12 kD FBD fused to the 33 kD CBD has been refolded and reoxidized using exactly the same method as the smaller FBD polypeptides.

20 The method of refolding and reoxidizing may additionally comprise contacting the polypeptide with a denaturant. Preferred denaturants are guanidine hydrochloride and urea.

25 Preferably, the polypeptide is at a low concentration, such as below 1,000 $\mu\text{g/ml}$.

30 The subject invention also provides a method for recovering a purified biologically active polypeptide having an amino acid sequence substantially present in the fibrin binding domain of naturally-occurring human fibronectin and being capable of binding to fibrin which comprises:

35 (a) producing in a bacterial cell by means of expression of a plasmid containing DNA encoding the polypeptide a first polypeptide having the amino acid sequence of the polypeptide but lacking the disulfide bond;

- (b) disrupting the cell so as to produce a lysate containing the first polypeptide;
- 5 (c) centrifuging the lysate so as to concentrate the first polypeptide;
- (d) separating the concentrated first polypeptide;
- 10 (e) solubilizing the separated, concentrated first polypeptide;
- (f) refolding and reoxidizing the solubilized first polypeptide so as to form the biologically active polypeptide;
- 15 (g) separating the refolded and reoxidized biologically active polypeptide;
- (h) recovering the purified, refolded and reoxidized biologically active polypeptide; and
- 20 (i) purifying the biologically active polypeptide so recovered.

25 Preferably, the refolding and reoxidizing comprises contacting the polypeptide with a thiol-containing compound in the presence or absence of a disulfide so as to refold and reoxidize the polypeptide. Preferably, the thiol-containing compound is selected from the group consisting of

30 glutathione, thioredoxin, β -mercaptoethanol, and cysteine.

In one preferred embodiment, the thiol-containing compound is β -mercaptoethanol and the disulfide is produced in situ by introduction of air.

Preferably, the polypeptide is selected from the group consisting of an 18.5 kD polypeptide, a 20 kD polypeptide, a 12 kD polypeptide and a 45 kD polypeptide. As noted above, the 45 kD chimera polypeptide consisting of the 12 kD FBD fused to the 33 kD CBD has been refolded and reoxidized using exactly the same method as the smaller FBD polypeptides.

The method may additionally comprise contacting the polypeptide with a denaturant, such as guanidine hydrochloride or urea.

Preferably, the polypeptide is at a low concentration, such as below 1,000 $\mu\text{g/ml}$.

Preferably, the separating of the concentrated polypeptide in step (c) comprises chromatography, preferably Heparin-Sepharose chromatography.

The subject invention also provides a method of inhibiting thrombus formation in a subject susceptible to thrombus formation which comprises administering to the subject an amount of a polypeptide (selected from the polypeptides and fused polypeptides disclosed above) effective to inhibit thrombus formation. The polypeptide may be reduced or alternatively the S-H groups may be blocked (e.g. by carboxymethylation or carboxamidomethylation to prevent reoxidation).

The subject invention also provides a polypeptide as disclosed above bound to a thrombolytic agent for the targeting of thrombolytic agents. The thrombolytic agents may be selected from tissue plasminogen activator (TPA), urokinase, streptokinase, prourokinase, Anisoylated Plasminogen-Streptokinase Activator Complex (EminaseTM), TPA analogs, or a protease.

In one embodiment of the invention, the polypeptide has an amino acid sequence substantially present in the fibrin binding domain of naturally-occurring human fibronectin, is capable of binding to fibrin, has a molecular weight above
5 about 6 kD but less than about 20 kD, has the amino acid sequence gln-ala-gln-gln or met-gln-ala-gln-gln at the N-terminus of the polypeptide and wherein the thrombolytic agent is streptokinase.

10 In a preferred embodiment, the polypeptide is a 12 kD polypeptide and the thrombolytic agent is streptokinase.

Further provided is a method for achieving thrombolysis of
15 a thrombus which comprises administering to a subject an amount of the polypeptide bound to a thrombolytic agent effective to achieve thrombolysis.

The invention also provides a method of treating a subject
20 with a wound which comprises administering to the subject an amount of a purified polypeptide, which is substantially free of other substances of human origin which has an amino acid sequence substantially present in the fibrin binding domain of naturally-occurring human fibronectin and is
25 capable of binding to fibrin, in conjunction with a polypeptide which comprises a substantial portion of the cell binding domain of naturally-occurring human fibronectin effective to treat the wound. In one embodiment of the method, the cell binding domain polypeptide is a 40 kD
30 polypeptide or a 33 kD polypeptide.

Further provided is a method of treating a subject with a wound which comprises administering to the subject an amount of the fused polypeptide of a purified polypeptide, which is
35 substantially free of other substances of human origin which has an amino acid sequence substantially present in the

fibrin binding domain of naturally-occurring human fibronectin and which is capable of binding to fibrin, fused to a second polypeptide which comprises a substantial portion of the amino acid sequence of the cell binding domain of naturally-occurring human fibronectin effective to
5 treat the subject. In one embodiment of the method, the fused polypeptide may be a 45 kD polypeptide, wherein the polypeptide is a 12 kD polypeptide and the second polypeptide is a 33 kD polypeptide. In another embodiment,
10 the fused polypeptide may be a 64 kD fused polypeptide, wherein the polypeptide is a 31 kD polypeptide and the second polypeptide is a 33 kD polypeptide.

The wound treated by the methods of the invention may be a
15 cutaneous wound, such as an incisional wound, a skin deficit wound, a skin graft wound, or a burn wound. The wound may also be an eye wound, wherein the eye wound is a corneal epithelial wound or a corneal stromal wound. Furthermore, the the wound may be a tendon injury.

EXAMPLES

All the references to map positions correspond to the identically numbered positions along the nucleotide sequence of human fibronectin cDNA shown in Figure 2 (see also Figure 3 of Baralle, F.E., European Patent Publication No. 207,751, published January 7, 1987).

This patent application is directed to polypeptide fragments of the N-terminus fibrin binding domain (FBD). Experimental results with the 31 kD polypeptide are presented for purposes of comparison with the shorter fragments. Some of the proteins described are fusion proteins comprising an FBD fragment joined at its C-terminus to the N-terminus of a fragment of the cell binding domain (CBD).

The cDNA sequence corresponding to the CBD which applicants have cloned and expressed is missing the 270 bp extra domain (ED) segment which extends from nucleotides 4811 to 5080, inclusive, on the Baralle map (see Figure 2). Thus, the cDNA sequence which is said to extend from nucleotide 3317 to 5566 on the Baralle map, contains only 1980 nucleotides, because it is missing the 270 nucleotides of the ED segment, namely from nucleotides 4811 to 5080 inclusive; this region is also known in the art as the ED-A region. Because nucleotide 5081 is changed from G to A, amino acid 1690 is changed from alanine to threonine. Similarly, the polypeptide expressed by that DNA fragment would encode from amino acid 1102 to amino acid 1851 on the Baralle map but would be missing the 90 amino acids encoded by the ED region, namely amino acids 1600-1689 inclusive, and thus it would contain only 660 amino acids. This is true for all CBD fragments described in this application which span the ED region. (The region known in the art as the ED-B region is missing both in Baralle's sequence and in applicants' cDNA.)

The EcoRI cleavage site shown at position 3317 was constructed by applicants during the cloning procedure by use of EcoRI linkers. This GAATTC sequence at positions 3313 to 3318 differs in 1 nucleotide from the corresponding Baralle sequence GATTC. This introduces a single nucleotide change C to A at nucleotide 3315. This changes the corresponding amino acid number 1100 from Thr to Asn.

EXAMPLE 1Preparation of a Fibronectin cDNA Library

5 A cDNA library was prepared in λ gt11 from poly A+ mRNA isolated from human liver according to the published procedures (13,14). The cDNA fragments were cloned using EcoRI linkers and the cDNA library was screened for fibronectin (FN) positive plasmids using the following synthetic DNA
 10 probes.

Probes for cell binding domain (CBD):

	<u>Probe</u>	<u>Nucleotides</u>
15	(3') CACTCTATAATGTCCTAGTGAATGCCTCTTTGTCCTCC	(4355- 4392)
	(3') AGAATCTCCTTCTGTCTTTTGTCCAGAACTAAG	(3967- 3999)
20	(3') CCGGTTGTTAGTTGTCAAAGACTACAAGGCTCCCTGGACC	(4200- 4239)

25 Probes for N-terminal fibrin binding domain (FBD):

	(3') GGGGGTCCGAGGGATACCGGTGACACAGTGTCTTAA	(817-850)
30	(3') CGACGGGTGCTCCTTTAGACGTGTTGGTTACTTCCCCAGTAC	(1310- 1340)

A series of FN cDNA clones covering the entire region of fibrin, collagen, heparin and cell binding domains was identified and isolated (Figure 9). The cDNA fragments were
 35 subcloned into the EcoRI site of pBR322.

The mRNA of FN is alternatively spliced and therefore different length cDNA's have been reported in the literature. Applicants' cDNA corresponding to the cell binding domain has a 270 base pair deletion from base 4811 to base 5080 on
5 the FN physical map (the complete non spliced cDNA).

EXAMPLE 2Expression and Purification of Fibrin Binding Domain (FBD)
Polypeptides

5

A. Expression of a partial FBD 20 kD polypeptide

The FN cDNA clones obtained as described in Example 1 and depicted in Figure 9, did not include DNA encoding amino acids 1-190 of the FN molecule. These amino acids are part of the FBD. The DNA corresponding to nucleotides 14 to 472 and coding for amino acids 1-153 (Figure 2A) was constructed by ligation of 7 pairs of chemically synthesized nucleotides (Figures 3 and 4). The synthetic DNA fragment was designed to contain an ATG initiation codon at the 5' end as well as convenient restriction sites for introduction into various expression vectors. To enable further manipulation of the DNA sequence coding for the FBD, nucleotide number 19, thymidine (T) was changed to adenine (A), thereby eliminating a DdeI restriction site without altering the amino acid sequence. (The site of the nucleotide change is denoted by an asterisk in linker #1 shown in Figure 3A.) The various steps for the cloning of the above synthetic DNA fragment into pBR322 plasmid vector digested with EcoRI and BamHI are described in Figure 4. The plasmid obtained was designated pFN 932-18. The DNA fragment coding for the first 153 N-terminal amino acids of fibronectin from plasmid pFN 932-18, was inserted into pTV 301, a λ P_L expression vector, between the NdeI and BglII sites replacing the DNA sequence coding for human growth hormone (hGH) in plasmid pTV 301 (Figure 5).

The resulting plasmid, pFN 949-2, was deposited with the American Type Culture Collection under Accession No. 67831. Plasmid pFN 949-2 was used to transform Escherichia coli prototroph A4255. These transformed Escherichia coli cells

were found to express the partial FBD polypeptide in amounts comprising about 5% of the total cellular proteins. The polypeptide has a mobility of about 20 kD on reduced SDS polyacrylamide gels as determined from the mobility of the size markers. The polypeptide comprises the first 153 amino acids of fibronectin followed by 4 amino acids coded for by a synthetic linker and then several amino acids resulting from readthrough into the pBR322 vector due to the lack of a TAA termination codon, i.e., a total of 153 amino acids plus less than 20 additional amino acids, with an additional N-terminal methionine. Throughout this specification the polypeptide is referred to as the r20 kD polypeptide or the r20 kD FBD.

15 B. Expression of a "complete" FBD polypeptide

In order to obtain expression of the entire FBD polypeptide containing amino acids 1 to 262 the following plasmids were constructed:

20

1. Insertion of termination codon TAA at the 3' end

A synthetic oligonucleotide containing a TAA termination codon and a BglII site having the following sequence:

25

```
5' CTGTTTAATAAGCA
3' GACAAATTCGTCTAG
```

was ligated to the 3' end of an EcoRI-PvuII fragment isolated from FN cDNA clone p931-5 and to a pBR322 vector digested with EcoRI and BamHI as described in Figure 6. The plasmid obtained was designated pFN935-12.

30

35

2. Subcloning of carboxy terminal region of FBD in a λ P_r expression vector

An EcoRI-HincII DNA fragment coding for the carboxy terminal region of the FBD was isolated from plasmid pFN935-12 and ligated to plasmid pTV 194-80 digested with EcoRI and SmaI as described in coassigned PCT Publication No. WO 90/07577 (Figure 46). The plasmid obtained was designated pFN 946-12.

3. Syntheses and cloning of DNA corresponding to nucleotides 468-599 of FN

10

Three pairs of chemically synthesized nucleotides were ligated to an EcoRI-DdeI FN fragment isolated from plasmid pFN932-18 (Figure 4) in the presence of pUC19 vector DNA (purchased from GIBCO BRL Co.) digested with EcoRI and XbaI as described in detail in the above-referenced PCT Publication (Figure 47). The plasmid obtained was designated pFN 948-4.

15

4. Construction of a plasmid encoding the complete FBD region

20

In order to construct a plasmid which codes for the entire FBD, amino acid 1 to amino acid 262, an EcoRI-XbaI DNA fragment coding for FN was isolated from plasmid pFN948-4 and inserted into plasmid pFN 946-12 digested with EcoRI and XbaI as described in the above-referenced PCT Publication (Figure 48). The plasmid obtained was designated pFN-957. This plasmid contains the complete coding sequence for FBD but does not express the FBD polypeptide as it lacks a ribosomal binding site (RBS).

25

30

5. Expression of the FBD under λ P_L promoter and cII RBS

35

An NdeI-HindIII fragment containing the FBD coding region and the T₁T₂ transcription terminators was isolated from

plasmid pFN-957 and inserted into plasmid pTV 301 digested with NdeI and HindIII as described in the above-referenced PCT Publication (Figure 49). The resulting plasmid, designated as pFN 962-3, directs the expression of a FBD polypeptide under the control of λ P_L promoter and cII ribosomal binding site. Escherichia coli strains A1645 and A4255 transformed with this plasmid expressed only small amounts of the FBD polypeptide. The expression of the FBD polypeptide was detectable only by Western blot analysis using polyclonal antibodies directed against human plasma derived FN.

6. Expression of an FBD polypeptide under the λ P_L promoter and the β -lactamase promoter and ribosomal binding site

As the level of expression of the FBD polypeptide obtained with plasmid pFN 962-3 was low, we added a DNA fragment coding for the β -lactamase promoter and β -lactamase RBS (PBLA). The DNA fragment coding for PBLA was isolated from plasmid pBLA11 (ATCC Accession No. 39788) and inserted into plasmid pFN 962-3 digested with NdeI, filled in with Klenow enzyme and digested with EcoRI (see the above-referenced PCT Publication). The plasmid obtained, designated pFN 975-25, was deposited with the American Type Culture Collection under ATCC Accession No. 67832. This plasmid was used to transform Escherichia coli prototroph A4255 (F+).

These Escherichia coli cells were found to express the "complete" FBD polypeptide at levels comprising about 5-8% of the total cellular proteins. The polypeptide migrated on SDS-PAGE gels under reducing conditions with an apparent molecular weight of 31 kD, hence it is referred to as the 31 kD polypeptide or the r31 kD FBD.

35

C. Fermentation and growth conditions

The clone expressing the r31 kD FBD polypeptide was fermented in rich medium (yeast extract and casein hydrolysate) containing ampicillin. Growth was carried out at 30°C. Expression was obtained upon induction at 42°C for 2 hours, and subsequently bacterial cell cake containing the r31 kD FBD polypeptide was obtained. Similarly, the clone expressing the r20 kD FBD was fermented and bacterial cell cake containing the r20 kD FBD polypeptide was obtained.

10 D. Refolding and purification of recombinant fibrin binding domain (r31 kD) polypeptide

The process is made up of three stages:

- 15 1. Crude processing of the bacterial cake.
2. Refolding/reoxidation.
3. Purification.

1. Crude processing

20

The cake is disrupted first in 5 volumes of 50 mM Tris-HCl/50 mM Na-EDTA, pH 8 (Buffer 1); the pellet is then treated with 1.2 volumes of Buffer 1 containing 100 mg/liter lysozyme (2 hours agitation at 37°C). Triton X 100 is added to the resulting suspension (to 1%), and after 30 min. at room temperature the suspension is centrifuged and the pellet is resuspended and washed twice with water. All these steps are performed by disruption of the pellet and centrifugation and the 31 kD stays in the pellet, as evidenced from SDS-PAGE gels.

30

The washed pellet is suspended in 14 volumes of 10 mM Tris-HCl/5 mM EDTA/2 mM PMSF/2mM 6-aminocaproate, pH 7.5 (Buffer A) and then treated successively with Buffer A containing: 35 1% decyl sulfate, 1% decyl sulfate/5% glycerol and 5%

glycerol. The final treatment is with Buffer A without additives.

2. Refolding/reoxidation

5

Principle: To dissolve the pellet in 6M guanidine-HCl - GuCl - in the presence of a thiol reducing agent, such as glutathione - GSH - and to refold/reoxidize at a lower GuCl concentration by the addition of oxidized glutathione-GSSG.

10

The washed pellet from step 1 above is dissolved in 150-700 volumes of 6M GuCl/3mM GSH in Buffer A. The concentration of GuCl is lowered gradually, i.e., first 2 M, then 1 M and 15 0.5 M, while keeping the concentration of all other components constant, except for the volume, which at this stage is brought to 500-1000 fold higher than that of the pellet. At one of the intermediate concentrations of GuCl, i.e., between 0.5 and 2 M, refolding is initiated by the 20 addition of 0.3 mM of GSSG and incubation at room temperature for 24-48 hours. The refolded 31 kD is then dialyzed against Buffer A without additives.

3. Purification

25

Concentration: The large volume of refolded 31 kD is first centrifuged to remove the insoluble pellet that contains no 31 kD and is then dialyzed against Tris-HCl, pH 7.8, before being concentrated and initially purified on a Heparin- 30 Sepharose column.

Improved procedures for refolding/reoxidation and purification of the polypeptide fragments of the FBD are described in Examples 5 and 10.

EXAMPLE 3Pharmacodynamics of the r31 kD, r20 kD, r18.5 kD and r12 kD Fibrin Binding Domain Polypeptide Fragments

5

The intensity and resolution of a clot (thrombus) image is governed by the interplay of the rate of incorporation of the radiopharmaceutical and its blood clearance rate. In order to elucidate the metabolic behavior of the r31 kD fibrin-binding domain, and to compare it to fibronectin (FN), the r31 kD fibrin binding domain and plasma fibronectin were both iodinated with ^{125}I by the ICl method (24) and injected intravenously into rats. The results are shown in Figure 7 which represents the pharmacokinetic behavior of ^{125}I -r31 kD FBD and ^{125}I -FN. Blood samples were withdrawn at the times shown on the graph.

Figure 7 demonstrates that the clearance rates of the two radioactive molecules are different and after 5 hours, only 3% of the r31 kD FBD but 20% of FN respectively remain in circulation.

Some of the rats were kept in individual metabolic cages, and accumulated urine and feces were collected at 7 hours and 24 hours. About 30% of the injected ^{125}I -r31 kD radioactivity was excreted in the urine during the first 7 hours, and more than 90% was excreted after 24 hours. All of the urinary radioactivity was trichloroacetic acid-soluble, which is indicative of proteolytic degradation. The analysis of a variety of organs (kidney, stomach, liver, lung, uterus, ovary, adrenal, colon, ileum, skin, brain, eye, muscle, bladder, heart, spleen, trachea, aorta and vena-cava) did not reveal any specific accumulation, and the kinetics of disappearance of the radioactivity followed a pattern similar to that of the blood. In most of the

organs, the specific radioactivity (cpm/gram tissue) was lower than that of the serum.

5 The results indicate that exogenous recombinant 31 kD amino-terminal polypeptide of FN is moderately degraded and excreted in the body. The pharmacokinetic behavior is not consistent with a first-order kinetics, which may indicate that the polypeptide is moderately distributed in the tissues and body compartments other than blood. This is
10 also evident from the finding that the degree of degradation does not increase during the 4-24 hour period, thus reflecting a gradual release of the polypeptide from body compartments. The exclusive and relatively early appearance of the metabolites in the urine indicates that the
15 polypeptide is readily excreted through the kidneys. The lack of accumulation of the material in the liver may be an indication that this organ is not a major locus of degradation and is not involved in detoxification.

20 The relatively short half-life of r31 kD FBD is important for its possible use in diagnostic imaging of thrombi. The recombinant 31 kD FBD (r31 kD) may be labeled radioactively or by other means and then introduced into the blood for the purpose of imaging thrombi.

25 The shorter half-life of the molecule is also important when utilizing it to prevent clot formation. By contrast, heparin, the current therapeutic agent of choice, suffers from a very long half-life.

30 A similar experiment was performed using iodinated 31 kD fibrin binding domain of plasmatc fibronectin and similar pharmacokinetics and distribution of radioactivity were observed.

35

The 31 kD polypeptide was obtained by cleavage of plasmatic FN as follows: the plasmatic FN was purified on a Gelatin-Sepharose column from which it was eluted and stored in 1 M guanidinium hydrochloride. Thereafter, 206 mg of FN, after dialysis against 10 mM of Tris-HCl, were digested with 0.01% of TPCK-trypsin at 37°C for 5 minutes. The tryptic digest was loaded on a DE52 column (6 ml) and 1/5 of the flow-through fraction (50 ml) was applied to a CM-Sepharose column (3 ml) and eluted with a NaCl gradient (0-0.5 M). About 80% of the polypeptide was recovered in the salt gradient (peak at about 220 mM) and after dialysis to remove the salt about 1/2 of the polypeptide was loaded on a Heparin-Sepharose column (1.5 ml) and eluted with 0.5 M NaCl. Approximately 75% of the polypeptide was recovered in this fraction, i.e., about 1 mg (about 40% of the theoretical yield). This fraction was >90% pure 31 kD polypeptide, and was iodinated by the method described above. In an improved embodiment the CM-Sepharose step is omitted and the Heparin-Sepharose step is performed directly after the DE52 column.

Note that plasmatic 31 kD FBD contains the first 259 amino acids of FN, whereas the recombinant 31 kD FBD contains the first 262 amino acids of FN and an additional N-terminal methionine.

Pharmacokinetics of the r20 kD, r18.5 kD and r12 kD fibrin binding domain polypeptides

Similar experiments were performed using labeled r20 kD, r18.5 kD and r12 kD fibrin binding domain polypeptides produced as described in Examples 2, 4, 5 and 10. The pharmacokinetics of these polypeptides was found to be very similar to that of the r31 kD polypeptide.

EXAMPLE 4Expression and Fermentation of Additional Fibrin Binding Domain (FBD) Polypeptides

5

In Example 2 the expression of a partial r20 kD FBD and the full-length r31 kD FBD was described and in coassigned PCT Publication No. WO 90/07577, Example 24, an improved procedure for refolding and purification of the 31 kD FBD was disclosed. The construction of plasmids for expression of additional polypeptide fragments of the FBD is now described.

10

A. Expression of r12 kD FBD polypeptide

15

Plasmid pFN 975-25, ATCC No. 67832, expresses the full-length r31 kD FBD of fibronectin and from it plasmid pFN 196-2 which expresses a partial FBD was constructed as shown in Figure 10. This plasmid was transformed into Escherichia coli strain A1645 and thence into Escherichia coli strain A4255 and deposited in A4255 in the ATCC under Accession No. 68328. These transformed cells were found to be good expressors of the partial FBD polypeptide in amounts comprising about 5% of the total cellular protein. The polypeptide has a mobility of about 14.4 kD on SDS polyacrylamide gels under reducing conditions as determined from the mobility of the size markers. The polypeptide comprises the first 109 amino acids of fibronectin. An additional methionine residue is present at the N-terminus of the final polypeptide. Throughout this specification this polypeptide is referred to as the r12 kD polypeptide fragment or the r12 kD FBD.

20

25

30

B. Expression of a modified 12 kD (12 kD') partial FBD polypeptide

5 Plasmid pFN 975-25 (ATCC No. 67832), which expresses the full-length r31 kD FBD, was used to construct plasmid pFN 197-10 which expresses a modified r12 kD polypeptide (r12 kD') as shown in Figure 11. The fibronectin FBD sequence was modified to produce an NdeI site immediately after
10 nucleotide 340. This plasmid was transformed into Escherichia coli strain A1645 and thence into Escherichia coli strain A4255. These transformed cells were found to be good expressors of the modified r12 kD partial FBD in amounts comprising about 5% of the total cellular protein.
15 The polypeptide has a similar mobility to the unmodified 12 kD FBD as determined on reduced SDS polyacrylamide gels. The polypeptide comprises the first 109 amino acids of fibronectin followed by additional amino acids histidine and methionine. An additional methionine residue is present at
20 the N-terminus of the final polypeptide. This polypeptide is designated the r12 kD' polypeptide or the r12 kD' FBD.

C. Expression of a modified r12 kD' FBD fused to the 33 kD cell binding domain

25 Plasmid pFN 197-10 which contains an NdeI site at the 3' terminus of the modified 12 kD FBD was used to construct a plasmid, designated pFN 202-5, which encodes the modified 12 kD FBD fused to the 33 kD cell binding domain (CBD). This
30 construction was performed as shown in Figure 12 where the 33 kD CBD fragment was taken from plasmid pFN 137-2 (deposited in the ATCC under ATCC Accession No. 67910). Plasmid pFN 202-5 was transformed to Escherichia coli strain A1645 and thence to Escherichia coli strain A4255 and is a
35 good expressor (8% of total protein). The 45 kD polypeptide consists of the 12 kD' FBD fused to the 33 kD CBD (first 109

amino acids of FBD followed by amino acid residues histidine and methionine followed by the CBD commencing with serine. An additional methionine residue is present at the N-terminus of the final polypeptide).

5

D. Expression of a 31 kD FBD polypeptide fused to the amino acid sequence DGRGDS

In order to obtain expression of a 31 kD FBD polypeptide fused at the carboxy terminus to the sequence asp-gly-arg-gly-asp-ser (DGRGDS) the following construction was made. Plasmid pFN 975-25 which expresses the 31 kD FBD was digested with PvuII and HindIII and ligated to a synthetic linker as shown in Figure 13. The resulting plasmid, designated pFN 195-4, was used to transform Escherichia coli strain A1645 and thence Escherichia coli strain A4255. These cells were found to be good expressors of the 31 kD-DGRGDS polypeptide, at levels of about 8% of total cellular protein. The sequence of this polypeptide is described in the description of Figure 13.

10
15
20

E. Expression of a fused 31 kD FBD-33 kD CBD

In order to obtain expression of a "full length" r31 kD FBD polypeptide fused to the r33 kD CBD the following construction was made.

Plasmid pFN 975-25 which expresses the 31 kD FBD was digested with PvuII and HindIII, and the large fragment resulting was ligated to a synthetic linker and to the r33 kD cell binding domain obtained from plasmid pFN 137-2 after NdeI and HindIII digestion (as shown in Figure 14). The resulting plasmid, designated pFN 194-2, encodes the r31 kD FBD linked to the 33 kD CBD. Plasmid pFN 194-2 was transformed to Escherichia coli strain A1645 and then to Escherichia coli strain A4255, and the resulting cells were

30

35

low expressors of a 64 kD polypeptide which comprises the 31 kD FBD fused to the 33 kD CBD. The sequence of this polypeptide is described in the description of Figure 14.

5 Fermentation and growth conditions

The clone expressing the r12 kD FBD polypeptide was fermented in rich medium (yeast extract and casein hydrolysate) containing ampicillin. Growth was carried out at 30°C. Expression was obtained upon induction at 42°C for 2 hours and subsequently bacterial cell cake containing the r12 kD FBD polypeptide was obtained. Similarly, cell cake containing other proteins described above was obtained.

15 F. Additional Plasmid Constructions

1. 18.5 kD FBD polypeptide fragment: As described above, (Example 2A) the 20 kD FBD fragment expressed by plasmid pFN 949-2 (ATCC No. 68456) contains up to 20 additional amino acids of the pBR 322 vector due to readthrough past the end of the FN gene in the absence of a properly located TAA transcription termination codon. In order to provide a more authentic "3 fingered" FBD polypeptide fragment than the 20 kD fragment described in Example 2A, a plasmid encoding an 18.5 kD FBD polypeptide was constructed.

The construction is shown in Figure 23 and described in the Description of the figures. The resulting plasmid designated pFN 208-13 expresses an 18.5 kD FBD polypeptide fragment under control of the P_L promoter and the β -lactamase ribosomal binding site. Plasmid pFN 208-13 was deposited in ATCC in *E. coli* A4255 under Accession No. 68456. This plasmid expresses the first 154 amino acids of fibronectin with an additional N-terminal methionine.

2. Improved expressor of the 12 kD FBD polypeptide fragment: Plasmid pFN 196-2 (ATCC No. 68328) expressing a 12 kD FBD polypeptide fragment (2 "fingers") under control of the λP_L promoter and β -lactamase ribosomal binding site was described above. In order to further improve the level of expression of the 12 kD fragment, plasmid pFN 203-2 was constructed as shown in Figures 26 and 27 and described in the description of the figures. Plasmid pFN 203-2 expresses the 12 kD fragment under control of the λP_L promoter, CII ribosomal binding site and a 36 bp trp transcription termination sequence. Plasmid pFN 203-2 was deposited in ATCC in E.coli A4255 under Accession No. 68606. These transformed cells were found to be good expressors of the 12 kD FBD polypeptide fragment in amounts comprising about 12-18% of the total cellular protein.

3. High expression of fused 31 kD FBD - 33 kD CBD Polypeptide: Plasmid pFN 194-2, a low-level expressor of a 64 kD fused FBD-CBD polypeptide under control of λP_L promoter and β -lactamase ribosomal binding site was described above. A plasmid was constructed to enable high level expression of the 64 kD polypeptide under control of the λP_L promoter, CII ribosomal binding site, and 36 bp trp transcription termination sequence. This plasmid, designated pFN 205-5 was constructed as shown in Figure 25 and described in the description of the figures.

Fermentation and growth conditions for all these expression plasmids (1-3 above) were essentially as described for production of the other FBD polypeptides (see Example 2C). Purification and refolding were as described in Example 5 and Example 10.

EXAMPLE 5Refolding and Purification of Recombinant 20 kD and 12 kD Fibrin-Binding Polypeptides of Fibronectin.

5

The process for refolding and purification of the r20 kD and r12 kD polypeptides is made up of three stages:

1. Crude processing of the bacterial cake.
2. Refolding/reoxidation.
3. Purification.

10

15

1. Crude processing

20

25

- 1.1 Washing and extraction of the pellet: The bacterial cell cake, obtained as described in Example 2 for the r20 kD polypeptide and as described in Example 4 for the r12 kD polypeptide, is disrupted and washed essentially as for the r31 kD polypeptide (see coassigned PCT Publication No. WO 90/07577, page 121 et seq.); however, changes were introduced in the extraction procedure used for both the r20 kD and the r12 kD polypeptides. The following is an example of the washing and extraction procedure performed on the bacterial cell cake of the r20 kD polypeptide; the r12 kD polypeptide is extracted in a similar way.

30

35

- 1.2 Procedure: Bacterial cake containing the r20 kD polypeptide was produced as described in Example 2 by fermentation of Escherichia coli strain A4255 harboring plasmid pFN 949-2. A portion of this bacterial cake (14.8 g) was suspended in 10 volumes of 50 mM Tris HCl, 50 mM EDTA (Buffer B), pH 7.5. The suspension was homogenized for 15-30 seconds at a medium speed,

sonicated 3 times for 4 minutes with pulsing, and centrifuged at 15,000 rpm for 30 minutes. The pellet was resuspended in 2.4 volumes (36 ml) of Buffer B. Lysozyme (0.1 mg/ml) was added and the suspension was
5 incubated in a water bath at 37°C for 2 hours with stirring. Triton X-100 was added to a final concentration of 1%, stirred at room temperature for 30 minutes and centrifuged. The pellet was resuspended
10 three times in 148 ml of water (i.e., 10 times the volume of the original pellet), homogenized, stirred for 30 minutes at room temperature and centrifuged. The final pellet weighed approximately 1.5 g, i.e., only 10% of the original weight; however, both the r20 kD and the r12 kD polypeptides stay in the pellet, as
15 evidenced by SDS-polyacrylamide gel-electrophoresis. The washed and extracted pellet was kept frozen at -20°C until further processed.

20 2. Solubilization and refolding of the extracted pellet

2.1 The reagents and procedure used for the refolding/-reoxidation are different in this case from those used for the r31 kD polypeptide. The extracted pellet of
25 the r20 kD or the r12 kD polypeptide is dissolved in 6 M guanidine-HCl (GuCl) in the presence of 50 mM β -mercaptoethanol and, following a tenfold dilution, is allowed to reoxidize by air.

30 2.2 Procedure: The frozen r20 kD pellet (1.5 g) was solubilized and homogenized in 10 volumes of 10 mM Tris HCl, 5 mM EDTA (Buffer C), pH 8.0, containing additionally 6 M Guanidine-HCl. The sample was reduced
35 by the addition of 57 μ l of undiluted β -mercaptoethanol (final concentration: 50 mM) and stirred in the absence of air, i.e., in a sealed container, for 30

minutes. It was then dripped at the rate of about 5 ml/min into 10 volumes (148 ml) of Buffer C, pH 8.0 and allowed to oxidize while being constantly and gently stirred, in an open beaker for 48-72 hours at room temperature. Alternatively, the oxidation was performed in a closed container in the presence of 0.3 mM GSSG. Although at this stage some polypeptide precipitation had already occurred, the suspension, including the precipitate, was dialyzed over 24 hours against 15 volumes of Buffer C, pH 8.5 with three changes of buffer. The dialysate was then subjected to centrifugation for 45 minutes at 15,000 rpm (22,500 x g) in a high-speed Beckman centrifuge equipped with a JA-17 rotor. This removes many contaminant proteins and aggregates of the r20 kD or r12 kD, which have been produced during reoxidation.

3. Purification and Characterization

Since the location of the heparin binding site within the fibrin binding domain was not known, it therefore could not be known in advance if the new shorter r20 kD and r12 kD polypeptides would bind to Heparin-Sepharose. However, we found that the shorter molecules did in fact bind to Heparin-Sepharose.

We found that there was no need for a phenyl-Sepharose column, as in the case of the r31 kD, in order to purify the reoxidized r20 kD or r12 kD polypeptides. In fact, the material could be directly purified on Heparin-Sepharose, but considerable improvement, with respect to removal of contaminants, incorrectly folded molecules and dimers, was achieved when the sample was chromatographed on a Q-Sepharose column before chromatography on a Heparin-Sepharose column. In some cases, the polypeptide was concentrated on a Pellicon

system (Millipore Corp.), using membranes with appropriate cut-off points, i.e., 10 kD for the r20 kD polypeptide and 3 kD for the r12 kD polypeptide, prior to being loaded on the Q-Sepharose column. The Heparin-Sepharose column is also used for concentration of both polypeptides. The following is an example of the purification procedure used in the case of the r20 kD polypeptide.

10 3.1. Q-Sepharose Chromatography: One-third of the reoxidized r20 kD (47 ml) was applied to a 10 ml column of Q-Sepharose Fast Flow column, which had been pre-equilibrated in Buffer C, pH 8.5 at 1.2 ml/min flow-rate. The flow-through fraction was collected and saved (70 ml). The polypeptides which adhered to the column were eluted with Buffer C, pH 8.5 containing 0.5 M NaCl and the column was regenerated with 0.5 M NaOH.

15 3.2 Heparin-Sepharose Chromatography: The flow-through from the Q-Sepharose column was applied to a 10 ml column of Heparin-Sepharose pre-equilibrated in pH 8.5 buffer at a flow rate of 0.5 ml/min. The flow-through fraction contained mostly contaminants and incorrectly folded r20 kD polypeptide. The purified (>95% pure) r20 kD polypeptide was eluted in Buffer C, pH 8.5 containing 0.5 M NaCl and the column was regenerated in the same buffer containing additionally 6M Guanidine-HCl. Representative purification tables for the r20 kD (Table A) and r12 kD (Table B) polypeptides are provided.

25 3.3 Characterization: Supernatants from the processing of the bacterial cake for both the r20 kD and the r12 kD polypeptide, as well as aliquots from subsequent column fractions, were assayed for polypeptide and analyzed by SDS-polyacrylamide gel electrophoresis; their elution

30

35

profiles were obtained on a Superose 12 column attached to either a FPLC or a HPLC. These profiles at various stages of the refolding, as well as of the purification, are shown for the r20 kD (Figure 21) and the r12 kD (Figure 22). The purified r20 kD or r12 kD polypeptides elute as single sharp bands. These profiles corroborate the results seen on SDS-PAGE gels under non-reducing conditions; the bands of both the 20 kD and the r12 kD polypeptides samples are non-diffuse, indicating a single molecular form. In the case of the r20 kD, the band of the non-reduced polypeptide runs (as in the case of the r31 kD polypeptide) faster than that of the reduced form; this is a similar effect to that seen in the case of the r31 kD polypeptide. However, no such difference is observed in the case of the r12 kD polypeptide. Additional details on characterization of FBD polypeptides are provided in Example 11.

These FBD polypeptides are available for radiolabeling in order to use them as radiopharmaceuticals for imaging of thrombi and atherosclerotic lesions.

The advantages of using the smaller FBD polypeptides (r20 kD and r12 kD) for the above-mentioned purposes as opposed to using the larger r31 kD polypeptide is that we have developed after considerable effort a simpler method for the preparation of the smaller molecules, i.e., the methods described above for the refolding and purification of the r20 kD and r12 kD polypeptides are faster and easier than the method for refolding and purification of the r31 kD polypeptide. In addition, these methods result in a higher yield than does the method for the r31 kD polypeptide and a higher concentration of polypeptide can be achieved for the shorter FBD polypeptide fragments (up to 10mg/ml).

An improved embodiment of this method for refolding and purification of the FBD polypeptide fragments is described in Example 10.

TABLE A: PURIFICATION OF THE r20 kD FBD

Step	Volume (ml)	Protein Conc (mg/ml)	Total Protein (mg)	Purity ^a (%)	Amount of FBD (mg)	Yield (%)	Degree of purifica- tion
Solubilized & Reduced Pellet	14.8	12.4	183.5	35	64.2	100	1
Oxidized Supernatant	148	0.72	106.5	45	48.0	74.7	1.3
Oxidized Supernatant (1/3)	47		33.8		15.2		
Q-Sepharose Flow-through	70	0.20	14.0	80	11.2	54.9	2.3
Heparin- Sepharose 0.5 M NaCl	9	0.71	6.1	98	6.0	29.4	2.8

^a Estimated from either SDS-PAGE gels under reducing conditions or from Sepharose 12 elution profiles.

This is a representative purification table for the refolding and purification of the r20 kD polypeptide, processed as described in Example 5, Sections 2 and 3.

TABLE B: PURIFICATION OF THE r12 KD FBD

Step	Volume (ml)	Protein Conc (mg/ml)	Total Protein (mg)	Purity ^a (%)	Amount of FBD (mg)	Yield (%)	Degree of purifica- tion
Solubilized & Reduced Pellet	100	6.66	666	10	66.6	100	1
Oxidized ^b Supernatant	500	0.20	100	58	58.0	87.1	5.8
Q-Sepharose Flow-through	500	0.13	65	80	52	78.1	8.0
Heparin- Sepharose 0.5 M NaCl	14	0.75	10.5	98	10.3	15.4	9.8

^a Estimated from either SDS-PAGE gels under reducing conditions or from Sepharose 12 elution profiles.

^b Concentrated on a Pellicon system.

This is a representative purification table for the refolding and purification of the r12 kD polypeptide, processed as described in Example 5, Sections 2 and 3.

EXAMPLE 6Biological Activity of the r31 kD, r20 kD and r12 kD Fibrin Binding Domain Polypeptides

5

The biological activity of the r31 kD FBD was described in coassigned PCT Publication No. WO 90/07577, page 134 et seq. relating to its binding to fibrin clot in vivo and in vitro, binding to bacteria and binding to extracellular matrix. In this example, additional results relating to the r31 kD polypeptide are presented and the biological activity of the 20 kD and 12 kD FBD polypeptides is demonstrated.

In this Example the binding of the recombinant fibrin binding domains to fibrin clots was measured as follows:

15

Binding of ^{125}I -rFBD (r31 kD, r20 kD or r12 kD) to a preformed fibrin clot (two-step Reaction II)

20

Step 1 Formation of fibrin clot: This may be done in one of two ways:

Either (a) Incubation at 37°C of 20 μl citrated human whole blood with 5 mM CaCl_2 , 1 unit/ml thrombin and PBS in a final volume of 250 μl . The reaction is terminated after 45 minutes by centrifugation and washing of the pellet (twice) with 1 ml PBS;

25

or (b) Incubation at 37°C of 20 μl non-citrated whole human blood ("naive" blood). The reaction is terminated after 150 minutes by centrifugation and washing as in (a).

30

Step 2 Binding of the ^{125}I -FBD polypeptide to the preformed fibrin clot

35

Clots are incubated at 37°C in a final volume of 250 μ l PBS with ^{125}I -rFBD polypeptide. Other constituents may be added as indicated for each experiment. The binding reaction is terminated after 45 minutes by centrifugation and washing three times with PBS. The tubes containing the ^{125}I -rFBD - fibrin pellet were measured for radioactivity in a gamma counter.

Results

A. Metabolic stability of ^{125}I -labeled r31 kD FBD in rats: ex-vivo binding to fibrin versus TCA insolubility

As described in the description of Figure 18, rats were injected intravenously with r31 kD FBD labeled with ^{125}I and blood samples taken at intervals were added to Na citrate. Aliquots of the blood were treated as follows: either (a) treated with 20% TCA and the TCA insoluble counts were measured; or (b) incubated with preformed clot (using 20 μ l whole blood from control rat); binding of the ^{125}I -31 kD FBD to preformed clot was measured under the conditions of the two-step Reaction II described above.

The radioactivity was measured by a gamma counter and the activity of each sample was calculated as a percentage of total cpm present in the reaction mixture.

The results demonstrated in Figure 18 indicate a good correlation between the physical decay of the r31 kD (as measured by the decrease in TCA insolubility) and the functional decay (as measured by the decrease in ex-vivo binding of the r31 kD to a preformed fibrin clot.) However, at the initial stage of the comparative studies there are marked differences; at 30 min. the functional decay is

several fold higher than the physical decay. These results, which suggest a much faster decrease of functional stability than physical degradation, can be explained since the main site for the covalent reaction of the FBD with the fibrin
5 clot is the glutamine residue located at the extreme amino terminus of the FBD molecule at amino acid no. 3; this glutamine residue, being located in a 20 amino acid stretch outside the Type 1 homology structure, is not protected from degradation by the tertiary structure, which is typical of
10 the rest of the FBD domain.

B. Specificity of binding of r31 kD to fibrin: effect of transglutaminase

15 The covalent binding of the fibrin binding domain of plasmonic fibronectin to fibrin in a clot is mainly due to the reaction of amino acid no. 3 of fibronectin (glutamine) with fibrin; this binding reaction is enzymatically controlled by the enzyme transglutaminase which specifically
20 recognizes the amino acid sequence containing this glutamine residue.

The following experiment was performed to investigate if transglutaminase is involved in the binding of the
25 recombinant r31 kD FBD to clots. All the exogenous transglutaminase used in the experiments described in this application is guinea-pig liver transglutaminase (Sigma).

The binding of 0.3 μ M solution of the following molecules to
30 preformed fibrin clot derived from 20 μ l of whole human blood was measured in the presence and absence of transglutaminase using the two-step Reaction II described above: 14 C-putrescine-r31 kD FBD, 125 I-r31 kD FBD and 125 I-recombinant bovine growth hormone (control). The 14 C-
35 putrescine-r31 kD protein complex where the glutamine

residue at position 3 is blocked by covalent reaction with ^{14}C -putrescine, was prepared as follows:

5 A solution containing 3 μM r31 kD FBD, 10 mM CaCl_2 , 0.015 units/ml transglutaminase and 60 μM ^{14}C putrescine (specific activity 100 mc/mmole) was incubated at 37°C for 5 hours. The amount of ^{14}C -putrescine incorporated into the 31 kD FBD was measured by TCA precipitation of an aliquot of this reaction solution and demonstrated the incorporation of an
10 equivalent amount to 2.8-3 μM solution of ^{14}C -putrescine into the r31 kD protein; this indicates that more than 90% of the glutamine at position number 3 of the FBD covalently reacted with the ^{14}C -putrescine. The ^{14}C -putrescine r31 kD material was stored at 0°C and used within a few days
15 without further treatment. The r31 kD FBD and the control recombinant bovine growth hormone analog (bGH) prepared as described in EPO Publication No. 131843 were labeled with ^{125}I using the ICl method described in Example 3.

20 Results

The counts bound in the two-step Reaction II in the presence and absence of transglutaminase were obtained and the ratio of counts bound in the presence and absence of
25 transglutaminase was calculated for each polypeptide tested. This ratio differs dramatically when intact 31 kD FBD is compared to putrescine-FBD ("blocked" FBD) or to the control bGH. In the two latter cases the ratio of counts is close to 1 which shows that transglutaminase does not affect the
30 binding and total cpm present in the clot is 10-15% of total cpm in the reaction). In the case of the intact 31 kD FBD the ratio is dramatically higher than 1 (in different experiments the ratio varied between 1.8-7 depending on the quality and freshness of the blood and the transglutaminase)
35 and total cpm present in the clot is 40-70% of total cpm in

the reaction) i.e., transglutaminase greatly increased the binding of r31 kD polypeptide to the clot.

5 These results indicate the strong effectiveness of unblocked glutamine at position number 3 for the binding of the r31 FBD polypeptide to the fibrin clot in the presence of transglutaminase.

10 Other experiments have shown that the addition of transglutaminase to the two-step Reaction II increases the binding of the r20 kD and r12 kD polypeptides to the clot, comparable to the effect observed with the r31 kD.

15 C. Characterization of r31 kD FBD-fibrin complex by SDS polyacrylamide gel electrophoresis

In order to determine the size of complex formed by the binding of r31 kD to a fibrin clot the following series of experiments was undertaken. Clots were derived from either
20 20 μ l whole human blood (A) or 250 μ l of a solution of 0.8 μ M human fibrinogen (B). In some of the fibrinogen experiments dental coils (as described in Example 7) were added to the tubes together with the fibrinogen.

25 The binding of 125 I-r31 FBD to the fibrin clot was measured using the two-step Reaction II described above, in the presence of 0.15 μ M 125 -r31 kD FBD and 5 mM CaCl_2 . The reaction was terminated by three times washing with PBS. The pellet, after the various treatments described below,
30 was centrifuged and 15 μ l aliquots of the supernatant (i.e., the soluble material) were electrophoresed on polyacrylamide gels which separates the material of molecular weight $>10^6$ from molecular weight $>10^5$ and from lower molecular weight materials. An autoradiogram was produced which shows the
35 following: in the presence of transglutaminase high molecular weight forms of r31 kD - fibrin complex appear

which are resistant to boiling in the presence of the strong ionic detergent SDS and β -mercaptoethanol, which reduces S-S bonds.

5 Additionally, when 4M urea is included in the boiling reaction the very high molecular weight forms ($>10^6$) are quantitatively converted to the intermediate molecular weight forms ($>100,000$) as expected for hydrophobic bonded aggregates of high molecular weight fibrin clots. The
10 amount of free r31 kD polypeptide in the clots is normally small; this is the material released on boiling with phosphate-saline buffer only. The resistance of the intermediate molecular weight forms to additional treatment with urea supports the involvement of a covalent linkage
15 between the ^{125}I -r31 kD and the fibrin.

D. Effect of fibronectin and heparin on the binding of ^{125}I -r31 kD to preformed fibrin clots

20 (i) Effect of fibronectin (FN)

Human plasma contains substantial levels of FN (300 $\mu\text{g/ml}$) which potentially could compete with the binding of ^{125}I -r31 kD polypeptide to preformed clots. Such competition may
25 affect the efficiency of clot radiolabeling and subsequently the imaging process. To examine the effect of FN, ^{125}I -r31 kD (0.15 μM) was added together with purified FN (1 μM) to a preformed clot in PBS. Although FN was added in a molar excess of 7 relative to ^{125}I -r31 kD, the binding of the
30 latter polypeptide was only slightly affected (20% inhibition). The observation that excess FN does not compete with ^{125}I -r31 kD binding could be interpreted in two ways: the number of sites for crosslinking onto the clot is in excess to accommodate both FN and ^{125}I -FBD, or: the
35 affinity of FBD to the clot is much higher than that of FN. Based on several observations, we believe that both excess

binding sites and higher affinity of the ^{125}I -r31 kD enable its binding to the clot in the presence of plasma concentrations of FN.

5 (ii) Effect of heparin

Some radioscintigraphic agents such as ^{111}In -labeled platelets and labeled fibrinogen are ineffective in the presence of therapeutic heparin. It was important, therefore, to analyze the effect of heparin on the incorporation of ^{125}I -r31 kD to the clots. The results showed that heparin has no significant effect on the binding of r31 kD FBD to preformed clots. Other experiments showed that the same amount of heparin affects dramatically the binding of r31 kD to a fibrin clot during its formation, i.e., Reaction I.

E. Comparison of the binding of various recombinant FBD polypeptides and plasmatic FBD to preformed clots

20 To compare the binding to preformed clots of the various recombinant FBD polypeptides (r31 kD, r20 kD and r12 kD) and plasmatic 31 kD FBD, a series of experiments using the two-step Reaction II was carried out as described in Figure 19. The results show that the plasmatic 31 kD binds to a similar level as the r31 kD whereas the r20 kD and r12 kD polypeptides both bind at about half the level of the larger (31 kD) molecule. The level of binding of the r20 kD and r12 kD polypeptides is still sufficiently high to demonstrate the potential of radiolabeled r20 kD and r12 kD polypeptides as radiopharmaceuticals for thrombus imaging. Similar experiments using the r31 kD-DGRGDS polypeptide (Example 4, D and Figure 13) showed that it binds at about the same level as the r31 kD.

F. Binding of ^{125}I -r12 kD to fresh or frozen clots

In order to study the effect of freezing the clots prior to use in binding experiments with FBD polypeptides, the following experiment was carried out. Fibrin clots were
5 either used fresh or after storage at -70°C in a two-step Reaction II binding experiment with ^{125}I -r12 FBD, prepared as described in Example 5.

The experiment was carried out as described in the
10 Description of Figure 15 in the presence or absence of transglutaminase. Figure 20 shows that there is little significant effect of freezing on the abilities of clots to bind r12 kD FBD. Normally, frozen clots without added transglutaminase yield binding results similar to fresh
15 clots in the presence of transglutaminase; there is no effect on the binding reaction when exogenous transglutaminase is added to frozen clots, probably because of the release of endogenous transglutaminase from the frozen red blood cells.

20

As noted in Section B above, there is a wide range of response to addition of exogenous transglutaminase in Reaction II.

25 G. Conditions for binding of ^{125}I -r31 kD FBD to preformed clots

To investigate the conditions for binding of ^{125}I -r31 kD to preformed clots, the following series of experiments were
30 carried out. The binding of ^{125}I -r31 kD polypeptide to preformed clots formed from citrated or "naive" blood was examined, using the two step Reaction II method, and in the presence or absence of various constituents (calcium, hirudin, transglutaminase). The pattern of results using
35 the "citrated" blood or "naive" blood clots is similar

although the binding of the r31 kD polypeptide is higher to citrated blood.

5 Hirudin (Sigma) is a specific inhibitor of any thrombin-mediated reaction and the hirudin was therefore added in order to investigate the effect of thrombin on the binding reaction (step 2). No effect of hirudin was shown and therefore thrombin has no effect on the binding of the r31 kD polypeptide to the clot. However, the same amount of
10 hirudin totally inhibits the binding when added at step 1 where fibrin is formed from fibrinogen, as was expected.

These results also show that exogenous transglutaminase increases the binding of r31 kD FBD to clots and furthermore
15 that this transglutaminase reaction is dependent on the presence of calcium ions. Since the exogenous transglutaminase used is tissue transglutaminase (in its active form) we expect that the serum transglutaminase, factor XIII, which has to undergo activation by thrombin to
20 form factor XIIIa, will be highly sensitive to hirudin inhibition.

H. Conditions for binding ^{125}I -r31 kD FBD to the extracellular matrix (ECM)

25

The binding of ^{125}I -r31 kD to the extracellular cell matrix of endothelial cells (ECM) was demonstrated in coassigned PCT Publication No. WO 90/07577, page 144. The binding was now further characterized by examination of the binding of
30 $0.3 \mu\text{M}$ ^{125}I -r31 kD FBD to ECM in the presence and absence of exogenous transglutaminase; additionally the binding in the presence of transglutaminase was examined in the presence of each of heparin, fibronectin or spermidine.

35 The results of these experiments demonstrate that the binding of the r31 kD FBD to ECM is increased by the

addition of transglutaminase. Heparin has no significant effect on the binding whereas spermidine, a known inhibitor of transglutaminase, inhibits the binding. Collagen also inhibits the binding, suggesting the possible involvement of collagen as an acceptor molecule on the matrix of the endothelial cells. Fibronectin has little effect on the binding reaction.

These results give more support to the potential use of radiolabeled recombinant FBD polypeptides as radiopharmaceuticals for imaging the initial plaque formation in denudated blood vessels.

Further experiments demonstrating the biological activity of various polypeptide fragments of the FBD of fibronectin are described in Example 9.

EXAMPLE 7Uptake of Recombinant ^{125}I -31 kD FBD and Fragments Thereof
by Stainless Steel Coil-Induced Venous Thrombi in Rats

5

The stainless steel coil-induced venous thrombus model in rats was used to study the uptake of labeled r31 kD, r20 kD and r12 kD FBD polypeptides. The model employed was as described by Maffrand et al. [Thrombosis and Haemostasis 59:
10 225-230 (1988)].

Experimental Details15 A. Investigation of the uptake of ^{125}I -31 kD by the
stainless steel coil-induced venous thrombus

Wistar-derived female rats (200-250 g) were anaesthetized by Ketamine HCl plus Xylazin HCl. A midline abdominal incision was made and the inferior vena cava was exposed. A
20 stainless steel wire coil (a dental paste carrier, fine No. 31, 21 mm long) was inserted into the lumen of the vein at the site just below the junction, and the incision was sutured. Each inserted device was individually weighed before insertion and each weight recorded. Three hours
25 after the operation, the animals were given an i.v. injection of 1 ml of 0.9% NaI solution in order to saturate the thyroid iodide pool. One hour later, the rats received an i.v. injection of ^{125}I -r31 kD FBD (5×10^6 cpm; 100 $\mu\text{g}/\text{kg}$). The r31 kD polypeptide was labeled as described in
30 Example 3. At 24 hours after the administration of the labeled polypeptide, blood was drawn by cardiac puncture, and the rats were sacrificed. The segment of the vein carrying the coil was removed while taking care to drain away all residual blood. In one group, the segments carry-
35 ing the coil were weighed as such and taken for measurement of radioactivity (the "Thrombus in Situ" group). In another

group the vein sections were incised longitudinally, and the coils carrying the thrombi were carefully removed, weighed and the radioactivity was measured. The blood radioactivity levels were measured using peripheral blood.

5

Calculation of the results:

In the two groups, the initial weight of each coil was subtracted from its final weight, and the specific radioactivity in each case was calculated by division of the cpm value by the net weight. The specific activity of the peripheral blood samples was also calculated.

Results:

15

At 24 hours, the blood levels of radioactivity were around 5000-10,000 cpm/g, while in the isolated blood clot the specific radioactivity was around 300,000 cpm/g, i.e., 30 to 60 fold higher (see Figure 16). When the entire segment of the vein carrying the clot was included in the analysis, and a so-called "specific radioactivity" value calculated, the resultant values were 4-5 fold higher than those of the blood, thus indicating that a good signal-to-noise ratio may be obtained for gamma-camera imaging of blood clots in vivo using labeled r31 kD FBD.

25

The effect of heparin pretreatment was studied in this model. This kind of experiment is essential because patients that are candidates for thrombus imaging are usually treated with this anticoagulation agent. In order to study this question, a group of rats were treated with heparin (500 units/rat intravenously) 10 minutes before administration of the labeled polypeptide. This treatment of heparin did not affect the uptake of label, as measured 24 hours later.

35

These results demonstrate that thrombus imaging using the FBD of FN may be done in the presence of heparin.

5 B. Comparison of recombinant 12 kD, 20 kD and 31 kD-FBD polypeptides in the stainless steel coil-induced venous thrombus model

10 The three recombinant polypeptides were labeled with ^{125}I as described in Example 3 and utilized in the rat model as described in A above. The results, shown in Figure 17, indicate that each of the three molecules was specifically localized in the clots as compared to the blood, by comparing the specific radioactivities; the specific radioactivity of the clots appeared to be higher with the longer molecules than the shorter polypeptides (143,000, 15 78,500 and 63,000 cpm/g clot for the r31 kD, r20 kD and r12 kD polypeptides, respectively), but the differences were not statistically significant. The specific radioactivity values for blood (after 24 hours) were similarly related to 20 the molecular size (7040, 5016 and 3300 cpm/g for the r31 kD, r20 kD and r12 kD polypeptides, respectively) and might reflect differences in the blood clearance rates of these molecular species. Hence, the calculations of the ratio of clot to blood specific radioactivity resulted in values that 25 were similar for the three different polypeptides, and ranged around 20. These results suggest that all three FBD species (or other fragments of the FBD) could serve for thrombus imaging.

EXAMPLE 8Labeling of the fibrin binding domain polypeptides for imaging atherosclerotic lesions and thrombi

5

The fibrin binding domain polypeptides described in this application (the r31 kD, the r20 kD and the r12 kD polypeptides), or other polypeptide fragments of the FBD, may be radioactively labeled to carry a radiotracer to a thrombus in order to permit its external detection by gamma camera imaging. This application discloses in Example 3 the labeling of these three polypeptides by means of iodine-125 (^{125}I), which has a long half life of 60 days.

10

Another radioiodine is iodine-131 (^{131}I) which may be used to label the FBD polypeptides using known methods such as described by Uehara et al (1). However, ^{131}I also has a relatively long half life of 8 days.

15

Optimally, a radiopharmaceutical for clinical imaging of atherosclerotic lesions and thrombi should yield positive results within the first few hours after injection (33). For such a test a shorter lived radiolabel could be used. Recent studies have suggested that indium-111 (^{111}In) or technetium-99m ($^{99\text{m}}\text{Tc}$) may be more suitable as radiotracers, since they have half-life of 67 hours and 6 hours, respectively (32); another short-lived low energy label is iodine-123 (^{123}I) with a half-life of 13.3 hours.

20

The labeling of the FBD polypeptides by $^{99\text{m}}\text{Tc}$ may be carried out using known methods (21, 33, 34, 35). $^{99\text{m}}\text{Tc}$ is a very suitable diagnostic single photon radionuclide because of its short half-life, a detection level of 140 KeV with the gamma counter, no particulate radiation and inexpensive, convenient availability. These attributes allow the routine administration of doses of 30m Ci that result in high

25

30

35

photon-flux levels facilitating lesion detection by single photon emission computerized tomography (32, 35).

5 Other radiolabels which may be used to label the FBD polypeptides include krypton-81m (^{81m}Kr) and xenon-133 (^{133}Xe), which has a half-life of 5.3 days, as reviewed by Knight (4). Another potential radiolabel is gallium-67 (^{67}Ga) as described by Yamamoto (36); ^{67}Ga has a half-life of 78 hours.

10

We have labeled the r31 kD, r20 kD, r18.5 kD and r12 kD polypeptides and the plasmatic 31 kD fragment by means of ^{111}In using the method described for human serum albumin by Hnatowich, D.J., Layne, W.W. and Childs, R.L. in J. Appl. Radiat. Inst. 33: 327 (1982). Preliminary experiments have shown that the labeled FBD polypeptides bind to preformed thrombi in vitro, measured by the two-step Reaction II (Example 6) and to thrombi in vivo measured by the model described in Example 7, and giving a high thrombus:blood ratio in the range of 80-200 after 24 hours.

20

Radiolabeling of the 12 kD and 18.5 kD proteins

DTPA modification of the 12 kD and 18.5 kD polypeptide fragments of the FBD was performed, essentially according to published methods (Hnatowich, D.J. Layne, W.W. and Childs, R.L. (1982) Int. J. Appl. Radiat-Isot. 33 327-332; Knight, L.C. Kollman, M, Maurer, A.H. and Budzynski, A.Z (1987) Biochim, Biophys. Acta 924 45- 53), using the cyclic anhydride of DTPA. Aliquots of a dry chloroform solution, containing calculated amounts of DTPA equivalents, were evaporated and reacted with the proteins, in either phosphate - or bicarbonate - buffered saline (pH 7.4 and 8.0±0.2, respectively). Excess of (hydrolyzed) DTPA was removed by exhaustive dialysis. Labeling was performed with carrier-free ^{111}In , in a HCl solution neutralized to about

35

pH 6 with sodium acetate. In one experiment (in PBS) the 12 kD polypeptide produced as described in Example 5 was labeled and this resulted in a thrombus to blood ratio (in the rat model) of 86 (see below), a calculated molar excess of DTPA - over the 12 kD protein - of 5 was employed (there are 5 lysyl ϵ -amino groups and 1 α amino group in the 12 kD protein). Upon labeling with ^{111}In , free (unbound) ^{111}In was estimated to be below 15% (by TLC).

10 In another set of experiments (in BBS), a 1:1 ratio between DTPA anhydride and either the 12 kD or 18.5 kD protein was employed.

In order to estimate the number of DTPA residues incorporated per molecule of 12 kD, DTPA-modified protein (before separation of the excess of DTPA) was labeled with ^{111}In (Knight et al., see above). The number of DTPA residues incorporated was found to be 0.12 per molecule of 12 kD. The DTPA-labeled 12 and 18.5 kD proteins had identical Superose 12 (gel-filtration) elution profiles as those of the control unmodified protein (retention times of 19.17 min and 18.29 min, respectively - control values are in Table E). Upon labeling with ^{111}In , after separation of excess DTPA, the amount of free (unbound) ^{111}In was found to be 28 and 29% for the 12 and 18.5 kD proteins, respectively, which resulted in thrombus to blood ratios (in the rat model) of 27 and 25, respectively.

NMRI, ultrasound and X-ray imaging with metal chelates are described in U.S. Patent 4,647,447. In addition, antibody coupling with metal chelates is mentioned at column 7, line 42. Monoclonal antibodies labeled with polymeric paramagnetic chelates and their use in NMRI methods have also been described [Shreve, P. et al., Magnetic Resonance in Medicine 3: 336-340 (1986) and Brady, T. et al. in Proceedings of the Society of Magnetic Resonance in

Medicine, Second Annual Meeting, Soc. of Magnetic Resonance in Medicine, Inc., San Francisco, p 10, 1983 referenced by Koutcher, J. et al., J. Nucl. Med. 25: 506-513 (1984)].

EXAMPLE 9Additional Experiments Demonstrating Biological Activity of Various FBD Polypeptides

5

The biological activity of the r31 kD, r20 kD, r12 kD FBD polypeptides has been described in Example 6. This example will disclose additional results observed using the FBD polypeptide fragments; these are the 12 kD obtained as described in Examples 4 and 5, and the 18.5 kD constructed, oxidized/refolded, and purified as shown in Examples 4 and 10.

I. Binding to Fibrin Clot

15

The clot formation and FBD binding were performed as described below in a modified version of the two-step reaction II described in Example 6. To avoid artifacts of aggregation and precipitation of the FBD polypeptides, the final centrifugation step is eliminated and the clot is transferred to a new tube and then extensively washed.

a. Clotting of "preformed clot"

25

Reaction mixtures (300 μ l) prepared in siliconized plastic vials (7 ml) of the gamma counter, contained 150 μ l of Mix I [0.2 x Tyrode's buffer ("1 X Tyrode's Buffer": 1 mM HEPES pH 7.35; Dextrose 0.2%; 27 mM NaCl; 0.76 mM NaH_2PO_4 ; .54 mM KCl; 0.2 mM MgCl_2), 3U/ml Thrombin (Sigma), 0.6% BSA (Sigma), 15 mM CaCl_2 , 150 mM NaCl, 20 mM NaHCO_3 , pH 8.0] and 150 μ l fresh citrated whole human blood.

30

35

Protocol: Incubation at 37°C for 3 hrs. The serum is removed by vacuum, and the tubes containing the fibrin

clot are kept frozen at -70°C . Preformed clots can be used for several months.

b. Binding of FBD to "preformed clot"

5

To vials containing "preformed clots" (thawed at room temperature), add 300 μl 150 mM NaCl, 20 mM NaHCO_3 , pH 8.0, containing: 1x Tyrode's buffer; 0.6% BSA; 5 mM CaCl_2 and 0.15 μM ^{125}I -FBD. The binding reaction is carried out (in the absence or presence of 0.03% sodium iodoacetate may be added to this mixture to inhibit the activity of the endogenous transglutaminase, Factor XIIIa) at 37°C for 18 hours. The clot is then transferred to a siliconized vial, washed 3 times with 1 ml "wash buffer" (20 mM NaHCO_3 , 1% BSA, 1 mM PMSF, 2 mM EDTA), and counted in a gamma counter.

10

15

The results comparing plasmatic and recombinant 31 kD with recombinant 18.5 kD, 12 kD, 45 kD (12 kD FBD fused to 33 kD CBD produced as shown in Figure 12), and 33 kD CBD are shown in Figure 30. All the FBD polypeptide fragments bound to a similar degree while the CBD polypeptide bound only to a very small degree. The 50-75% inhibition caused by the addition of the transglutaminase (Factor XIII) inhibitor iodoacetate shows that transglutaminase is active in the binding reaction. Its lack of effect on 33 kD CBD binding to clot indicates that CBD binding to clot is mediated by a different, possibly non-specific mechanism. As previously shown in coassigned PCT Publication No. WO 90/07577 (page 138, lines 1-24), the FBD is covalently bound to the fibrin clot. The participation of transglutaminase as shown and the biochemical characterization of ^{125}I -FBD-fibrin complex indicate that at least 70% of the FBD polypeptide is covalently bound to the fibrin.

20

25

30

35

II. Binding to Vascular Components

In addition to specific binding to fibrin, FBD polypeptides also show a certain degree of non-specific binding to other vascular components with which they come in contact. Examples of vascular components are endothelial cells (EC),
5 extra cellular matrix (ECM), and even fibronectin itself (FN). This non-specific binding is one of the factors that determine the background level when performing diagnostic imaging procedures. The lower the non-specific binding, the more effective the imaging and the less the total
10 radioactive reagent it is necessary to administer to the patient. Therefore experiments were performed to compare non-specific binding to vascular components of the 12 kD FBD fragment and 31 kD FBD polypeptide.

15 1 ml aliquots of $0.3 \mu\text{M}$ ^{125}I -12 kD or ^{125}I -31 kD (5×10^5 cpm/ μg and 7.5×10^5 cpm/ μg in PBS containing 0.1% BSA, respectively), were added in duplicate to 35mm petri dishes (Falcon) containing: confluent endothelial cells ("EC"), Extracellular matrix ("ECM"), (Eldor et al., Blood 65:1477
20 (1985)) or immobilized human fibronectin ("FN"), (1 ml per plate of PBS containing $50 \mu\text{g}/\text{ml}$ FN, incubated at 4°C overnight and then incubated for two hours at room temperature with 1 ml of PBS containing 1% BSA for blocking). When indicated "+TG", plates also contained
25 transglutaminase at 0.02 U/ ml (Sigma). Experimental plates were incubated for 60 minutes at 37°C in a CO_2 incubator, washed 3 times with 1 ml "washing solution" (PBS containing 2 mM PMSF and 2 mM EDTA). Bound radioactivity was then extracted by incubation for 60 min. with "Extraction
30 solution" (washing solution containing 1% deoxycholate, 2 mM PMSF, 2 mM EDTA, 2 mM NME, and 2 mM iodoacetic acid). The solution is then transferred to tubes and the radioactivity measured in a gamma counter.

35 The results summarized in Figure 28 show that the 12 kD FBD polypeptide binds only weakly to the vascular components

endothelial cells, extracellular matrix, and fibronectin by comparison to the binding of the 31 kD FBD polypeptide.

III. Bacterial Binding

5

The involvement of fibronectin in adhesion to, and invasion of, wounds by a wide range of gram-positive bacteria is well established (18). The fibrin binding domain of authentic plasma derived FN has been shown to interact with high affinity to specific receptors on the surface of bacteria. The sites at which Staphylococcus aureus typically initiates infection are rich in FN, e.g. blood clots and subendothelium. Furthermore, exogenous FN enhances bacterial adhesion to these sites. FN binds to S. aureus through saturable, specific surface protein receptors. Scatchard analysis has revealed high affinity receptors with binding constant of 5×10^{-9} M, and a range of 100-20,000 receptors per bacterium (19). The expression of FN receptors correlates with invasiveness and pathogenicity of the clinical isolates. Removal of the FN receptors from S. aureus by mechanical means, or by growth of the bacteria in the presence of antibiotics decreases their ability to adhere to FN. As FN is a divalent molecule consisting of multiple functional domains with cell binding and collagen binding activities in addition to bacterial binding, it can anchor the bacteria to the wound via the various components of the extracellular matrix as well as via the FN receptor in tissue cells.

30 Another approach to understanding the interaction between FN and S. aureus is through the inhibition of the binding of S. aureus to endothelial cells by the FBD polypeptide fragments.

35 Binding of the 31 kD FBD polypeptide to S.aureus has previously been disclosed (coassigned PCT Publication No.

WO/90/07577, pages 146-153). Similar experiments describe below showed that in contrast to the 31 kD FBD polypeptide, the 12 kD and 18.5 kD FBD polypeptide fragments do not bind S. aureus, and do not inhibit S. aureus in binding experiments. However, the 20 kD polypeptide does inhibit the binding of S. aureus (see Figure 8); this may be due to the additional (non-authentic) C-terminal amino acids (see Example 2) which may affect its activity directly or indirectly through some specific refolding.

10

The following sections are presented in order to compare the 31 kD FBD polypeptide to other FBD polypeptide fragments both in terms of direct binding to S. aureus, and in terms of inhibition of binding of S. aureus to endothelial cells.

15

Materials and Methods

A. Binding of labeled FN or FBD to bacteria

5 1. Direct binding in solution

Various concentrations of ^{125}I -r31 kD FBD or ^{125}I -FN, were added to 5×10^8 S. aureus bacteria in a PBS solution additionally containing 0.1% Tween and 1% BSA. The final
10 volume was 1 ml. Total radioactivity in the reaction was assayed using a 20 μl aliquot taken immediately after the addition of the bacteria.

The mixture was incubated for 2 hours at 20°C while rocking.

15

The amount of binding was assayed by removing 100 μl of the incubation mixture and layering on top of 0.5 ml PBS layered on 3 ml 10% Percoll-0.15 M NaCl in a 5 ml
20 siliconized tube. This was then centrifuged at 1,350 x g (4,000 rpm in a SW bucket rotor) for 15 minutes at 20°C. The supernatant was aspirated and the pellet assayed for radioactivity.

25 2. Competition with unlabeled FN, FBD and related molecules

The procedure followed was identical to the above procedure except that 3 $\mu\text{g}/\text{ml}$ ^{125}I -p31 kD was used and the specified amount of the competing molecule (FN or FBD) was also added
30 to the initial binding mixture.

3. Binding of radioactively labeled bacteria to immobilized FN

5 Plastic vials were coated with 0.3 ml of 50 μ g/ ml FN, or 1% BSA.

The tubes were incubated with shaking at 4°C overnight. The tubes were then washed with 5 ml PBS three times. Then 0.3
10 ml of 1% BSA in PBS was added and the tubes were further incubated with shaking for 2-3 hours at 20°C (for blocking free sites).

In indirect-binding experiments, the bacteria were pre-
15 incubated with inhibitor, at 4°C for 2 hours.

The bacteria (4×10^6 pfu/ ml, 3 pfu/cpm) were added to the vials at concentrations indicated in the figure legends. The final volume of the assay mix was 0.3 ml PBS. The mix
20 was slowly agitated at 4°C for 90-120 minutes.

The tubes were then decanted and washed with 5 ml PBS three times.

25 5 ml of scintillation-liquid was added when assaying for binding of ³H-labeled bacteria.

B. Inhibition of Binding of S. aureus to Endothelial Cells by FBD Fragments

I. Iodination of S. aureus

5

S. aureus SA113 (ATCC Accession No. 35556) were grown in Tryptic Soy Broth (Difco Laboratories, U.S.A.) at 37° using a 1 l fermentor culture. Bacteria were harvested in the middle of the logarithmic phase when optical density reached 2.30 OD (at 660 nm). The bacterial pellet was resuspended in 500 ml of PBS containing 5 mM PMSF and washed 3 times. The cells were then suspended in 100 ml PBS with 1 mM PMSF and 5 mM NEM (N-Ethyl maleimide, Sigma E-3876), heat-inactivated at 88°C for 20 min. for fixation, cooled in ice-water and then stored in small aliquots at -20°C. Before use, the bacterial concentration was brought to 5×10^9 PFU/ ml. A 100 μ Ci aliquot of Bolton-Hunter reagent for protein iodination (Amersham) was evaporated in a glass tube on ice. Bacterial suspension (1 ml) was added to the evaporated reagent and mixed gently for 10' on ice. The reaction was stopped by adding 1 ml of 0.2M glycine in 50 mM potassium phosphate buffer pH 8.5. The reaction mixture was then suspended in 20 ml PBS containing 1 mM PMSF. After centrifugation at 3000 rpm for 10' at 5°C, the wash step was repeated twice. The final pellet was suspended in 2.2 ml PBS containing 1 mM PMSF and stored at -20°C. The specific activity was generally 20-100 PFU/cpm.

II. Growth of Endothelial Cells

5 Bovine Aortic Endothelial cells A₅P₇ (obtained from A. Eldor, Hadassa Hospital, Jerusalem), were maintained in tissue culture as previously described (Ogawa S.K. et al 1985 Infect. Immunol. 50: 218-224). The culture media contained DMEM/+1% D-Glucose and 10% FCS (both from Biological Industries, Kibbutz Beth-Haemek, Israel) 10 supplemented with L-glutamine and gentamycin (7 mM and 5mg/ml, respectively, both from Sigma Chemicals).

The cells were maintained at 37°C and 5.5% CO₂ in 150 ml tissue culture flasks (Falcon).

15

Confluent monolayers for binding experiments were prepared in either 24 well tissue culture plates or 35 mm tissue culture plates (Corning Glassware, Corning N.Y.). Wells and plates were preincubated for 30 min. with 0.5 ml or 1 ml complete medium, respectively, prior to the addition of cell 20 suspension. In a typical experiment, wells and plates were seeded with 5 x 10⁴ and 10⁵ cells, respectively, and used after 3-4 days when culture became confluent.

25

III. Binding of ¹²⁵I-S. aureus to Endothelial Cells

This procedure is essentially as described in the above 30 mentioned reference (Ogawa et al. 1985). An aliquot of labeled S. aureus prepared as described above was diluted in PBS to 10⁸/ ml. 3.5 μl of labeled bacteria were added to a mix containing 200uL DMEM +10% FCS, 33uL 150 mM NaCl containing 20 mM NaHCO₃, 17 μl of PBS or the competitor to 35 be tested, and then incubated for 2 hours with gentle mixing. The bacteria were then added to confluent monolayers

of endothelial cells pregrown as described above . The endothelial cells were washed with saline immediately prior to performing the assay. The mixture was incubated at 4°C for 1 hour with gentle shaking or 2 hours at 37°C in 5% CO₂ without shaking. The unbound labeled bacteria were removed by washing 3 times with cold PBS containing 2 mM PMSF and 2 mM EDTA. The bound labeled bacteria were then extracted by shaking at room temperature for one hour in PBS containing 1% deoxycholate, 20 mM Tris HCl pH 8.3, 2 mM PMSF, 2 mM EDTA, 2 mM NEM, and 2 mM iodoacetic acid. The extraction was repeated once, and the combined extract was counted in a gamma counter.

Results

15

A. Binding of bacteria to ¹²⁵I-FN or FBD in solution

1. Direct Binding

20 Experiments were performed in order to determine the binding of ¹²⁵I-FN or ¹²⁵I-rFBD to S. aureus bacteria in suspension. Various amounts of radioactive FN or r31 kD were added to 5 x 10⁸ bacteria incubated for 2 hours and then centrifuged over a 10% Percoll-saline solution. Radioactivity was monitored in the pellet.

25

The results showed increased binding of ¹²⁵I-rFBD (r31 kD) to the bacteria in suspension as compared to the binding of the ¹²⁵I-FN.

30

This increased binding of ¹²⁵I-rFBD to S. aureus as compared to ¹²⁵I-FN binding to S. aureus can be attributed to a higher affinity of a monovalent domain in comparison to bivalent multidomain of intact plasma derived FN.

35

Similar experiments performed with the 12 kD and 18.5 kD FBD fragments showed no binding whatsoever.

2. Competition with "native" unlabeled FN, FBD and Related
5 Molecules

A fixed amount of ^{125}I -p31 kD (3 $\mu\text{g}/\text{ml}$) was incubated with 5×10^8 bacteria in the presence of increasing amounts of various FBD molecules as competitors.

10

The results demonstrate that "native" FN, as well as properly folded p31 kD or r31 kD FBD inhibited the binding of ^{125}I -p31 kD to S. aureus in a similar fashion, indicating that recombinant 31 kD is as active as the natural plasma-derived molecules. However, the reduced ("scrambled") forms of recombinant or plasma derived FBD only minimally inhibit the binding of ^{125}I -FBD to the bacteria, indicating that proper folding is necessary for binding. Furthermore, r18.5 kD and r12 kD FBD polypeptides as well as a CBD polypeptide (33 kD cell binding domain of FN) did not compete with binding of ^{125}I -pFBD to S. aureus, showing conclusively that only the complete 31 kD FBD domain has bacterial binding activity while the shorter FBD fragments do not bind bacteria.

15
20
25

B. Binding of labeled S. aureus to immobilized FN

To estimate the capacity of rFBD (r31 kD) to interfere with the adherence of bacteria to the extracellular matrix in wounds, a competition assay was developed. In this assay, adherence of S. aureus to plastic surface coated with FN, and the interference of FBD with the binding was measured.

30

The results demonstrate that the adhesion of S. aureus to FN coated plastic vials was inhibited following pre-incubation of S. aureus with FN, pFBD (31 kD) or rFBD (31 kD). The

35

extent of inhibition by these molecules was similar. A non-related protein, BSA, which does not have S. aureus binding sites, did not cause any inhibition in adhesion of radioactive labeled S. aureus to FN coated plastic vials.

5

In similar experiments performed with the 12 kD FBD fragments, no inhibition of binding of S.aureus to immobilized FN was detected.

10 C. Inhibition of Binding of S. aureus to Endothelial Cells

Figure 29 shows the inhibition by FBD fragments of binding of S. aureus to endothelial cells as described above. The 31 kD shows a dramatic and dose dependent effect on S. aureus binding to endothelial cells. However, neither the 18.5 kD nor the 12 kD have any inhibitory effect, showing that the binding site on the FBD for the S. aureus receptor is not found on the 12 kD and 18.5 kD fragments. This is a surprising result since this is the first demonstration that the bacterial binding domain of the FBD of fibronectin can be separated from the S. aureus binding domain.

Summary and Conclusion

25 Table C summarizes and compares the activities of various FBD polypeptide fragments as described above.

Table C: Comparison of Activities and Binding Specificity of Various FBD Polypeptide Fragments

Activity	31 kD	18.5 kD	12 kD
Fibrin Binding	High	High	High
Binding to Vascular Components	High	Low	Low
Bacterial Binding	Yes	No	No
Inhibition of Binding of <u>S. aureus</u> to Endothelial Cells	Yes	No	No

It is thus seen that the 18.5 kD and 12 kD FBD polypeptide fragments have a high covalent binding specificity for fibrin, together with a narrower spectrum of activities and lower specificity for other ligands such as vascular components and bacteria than the 31 kD. This is an advantageous characteristic for a thrombus imaging agent, ensuring that as a diagnostic reagent it has a high affinity for fibrin-containing thrombi, while maintaining low background levels. An in vivo example of this is provided in Example 13.

EXAMPLE 10An Improved Method of Refolding/Oxidation and Purification of Shorter FBD Polypeptides Fragments

5

The recombinant FBD proteins - r31 kD ("5 fingers"), 18.5 kD (a more authentic version of the "3 fingers" than the previously described 20 kD) and r12 kD ("2 fingers") - are expressed in E. coli and refolded/reoxidized, before being

10 purified to homogeneity (>98% purity). The refolding/reoxidation processes used for the full 31 kD FBD polypeptide (5-fingered) and for the shorter 12 kD and 18.5 kD FBD polypeptide fragments (2- and 3-fingered) are different and have been described above in Examples 2 and 5.

15

The method of Example 5 has been found to be applicable to all 2- and 3-fingered FBD proteins, that have so far been refolded, but not to the 5-fingered protein, the 31 kD, even when the reduction (followed by reoxidation) is performed on purified plasma-derived 31 kD, i.e., "opening"

20 and refolding the protein. This procedure has recently been improved without affecting the principle of the refolding process, and the improved procedure has been found applicable to the 12 kD, 18.5 kD, and 20 kD polypeptides, and to the 45 kD FBD-CBD hybrid polypeptide (12 kD-33 kD)

25 but not to the 31 kD polypeptide.

The process is essentially as described in Example 5. The following description relates to the 12 kD polypeptide and similar results were obtained for the 18.5 kD FBD

30 polypeptide and 45 kD FBD-CBD hybrid polypeptides; these polypeptides were expressed by plasmids pFN 203-2 (Figure 27), pFN 208-13 (Figure 23) and plasmid pFN 202-5 (Figure 12), respectively.

35

The bacterial cake was produced as described in Example 2 by fermentation of E. coli strain A4255 harboring plasmid pFN 203-2 (as described in Figure 27).

5 A. Crude processing of the bacterial cake: The washing and extraction of the pellet was performed in a similar manner to that of the two- and three-fingered FBD proteins (see Example 5). The bacterial cake was suspended
10 in 20 volumes of 50 mM Tris HCl, 50 mM EDTA, pH 7.4. After 15 minutes of stirring, the suspension was disrupted by twice passing it through a Dynomill kD 5 bead mill at 50 liters/hour. The disrupted suspension was centrifuged (14000 x g in a Ceba 101 centrifuge at a feed rate of 80 liter per hour. The pellet was suspended in the above buffer to a
15 final volume 10 times that of the original bacterial cake's dry cell weight. The suspension was brought to 37°C and lysozyme added (2500 U/ ml). After 2 hours of stirring at 37°C, Triton X-100 (1%) was added and incubation with stirring continued for 30 min at room temperature. The
20 suspension was then diluted with an equal volume of deionized water, sonicated by a W 370 sonicator and centrifuged at 14000 x g under the same conditions as above. The pellet was washed twice by resuspending in deionized water to a final volume 16 times that of the dry cell weight
25 of the bacterial cake, and stirring for 15 min at room temperature at pH 7.4. After stirring the suspension was sonicated with a W 370 sonicator and centrifuged at 14000 x g under the same conditions as above. The washed and extracted pellet containing inclusion bodies of the FBD
30 polypeptide is kept frozen at -20°C until further processing.

B. Refolding/reoxidation: The resulting washed
35 inclusion bodies (100 g - representing 19.2 g of dry weight) were solubilized in 5 volumes of 10 mM Tris HCl pH 8.0, 5

mM EDTA, 1 mM phenylmethanesulfonyl fluoride (PMSF), 10 mM ϵ -aminocaproic acid, containing additionally 6 M guanidine HCl (final volume 600 ml). The sample was reduced by the addition of 2.27 ml of β -mercaptoethanol (final concentration: 50 mM) and stirred at room temperature in the absence of air, i.e., in a sealed container, for 90 minutes. The reduced protein was reoxidized (at a protein concentration of 0.81 mg/ml) in 0.54 M guanidine HCl, as follows: 6 liters of the Oxidation Buffer (10 mM Tris HCl pH 8.0, 5 mM EDTA, 1 mM PMSF 10 mM ϵ -aminocaproic acid, containing additionally 0.3 mM oxidized glutathione (GSSG), were added to the solution of the reduced protein while stirring at a rate of 150 ml per min. The oxidation process was continued for 65 hours at room temperature in a closed container, while being constantly and gently stirred. The solution of the reoxidized protein was filtered through Whatman No. 3 filter paper to remove the precipitates and then concentrated 10-fold on a Pellicon tangential flow ultrafiltration unit equipped with a 3 kD MW cut off membrane and diafiltered on the same membrane, in order to remove the guanidine HCl, the β -mercaptoethanol and the GSSG. A further precipitate, which developed upon standing at 4°C overnight, was removed by centrifugation at 22,500 x g for 45 minutes. (For the 18.5 kD and 45 kD polypeptides, ultrafiltration and diafiltration were performed with a 10 kD molecular weight cutoff membrane.)

C. **Purification:** The concentrated and clarified solution (700 ml) was loaded on a Q-Sepharose column (2.5 x 28.5 cm), equilibrated in 10 mM Tris HCl, 5 mM EDTA, 1 mM PMSF 10 mM ϵ -aminocaproic acid, pH 8.0. The flow-through of the column, containing the 45 kD protein, was applied - in portions of 170-350 mg) onto a Heparin-Sepharose column (2 x 6.5 cm), equilibrated in 10 mM Tris HCl, pH 8.0, 5 mM EDTA. After washing the unbound protein with this buffer, the bound protein was eluted with the same buffer,

containing additionally 500 mM NaCl. The eluates were pooled and kept frozen at -20°C.

- 5 As stated above, this procedure was applied with minor modification to both the 18.5 kD polypeptide and the 45 kD FBD-CBD hybrid polypeptide. The results for both these polypeptides were very similar to those obtained for the 12 kD polypeptide.
- 10 Use of buffer containing at least 0.5M NaCl for elution from Heparin-Sepharose and storage was found to be necessary to ensure stability of the polypeptides, which otherwise tended to rapidly lose their activity; this applies particularly to the 31 kD polypeptide.

15

EXAMPLE 11Characterization of FBD Polypeptide Fragments

5

I. Procedures

The FBD polypeptide fragments produced by the methods of this application were evaluated and compared in a series of characterization tests by the following methods known in the art.

1. **SDS-PAGE +ME** (ME = β -mercaptoethanol): 12.5 % acrylamide slab gels are loaded with protein, which had previously been treated by boiling 5 minutes in sample buffer containing 1% SDS - under reducing conditions (+ 1% ME). Electrophoresis was performed with 20 μ g per lane and the gels stained with Coomassie Brilliant Blue. The parameters measured are: a) the mobility, which, when compared with molecular weight markers (94, 67, 43, 30, 20.1 and 14.4 kD) can be expressed in terms of an apparent molecular weight for the protein studied; b) the homogeneity or purity, which can be assessed from the relative intensities of the major and minor bands.

25

2. **SDS-PAGE -ME**: 12.5 % acrylamide slab gels are loaded with protein, which had previously been treated - 5 min boiling in sample buffer containing 1% SDS - under non-reducing conditions (-ME). Electrophoresis is performed with 20 μ g per lane and the gels stained with Coomassie Brilliant Blue. The parameters measured are: a) the mobility, which, when compared with molecular weight markers (94, 67, 43, 30, 20.1 and 14.4 kD) can be expressed in terms of an apparent molecular weight for the protein studied; b) the homogeneity or purity, which can be assessed from the relative intensities of the major and minor bands

35

- in particular, under these conditions, one can evaluate the amounts of disulfide-linked dimers.

3. **Gel filtration on Superose 12:** The apparent
5 molecular weight and the homogeneity of the protein
preparations were evaluated from elution profiles obtained
on a Superose 12 column (HR10/30, Pharmacia Fine
Chemicals), attached to either an FPLC apparatus, equipped
with a liquid chromatography controller LCC-500 and recorder
10 (Pharmacia Fine Chemicals) or to an HPLC system (Waters
Associates), consisting of 2 pumps (Model 501), an injector
(Model U6K) and an automated gradient controller (Model 580)
equipped with a variable wavelength detector -
Spectro-Monitor 3000 (LDC/Milton Roy) - and a
15 Chromato-Integrator (Merck-Hitachi, Model 2000). The column
was calibrated by the following molecular weight standards,
whose retention times were determined : bovine serum albumin
(67 kD), ovalbumin (43 kD), chymotrypsinogen (25 kD) and
ribonuclease (13.7 kD). The flow rate was 0.8 ml/min, using
20 the standard running buffer, i.e., 150 mM NaCl - 20 mM
Tris.HCl, pH 7.8-8.0. Two parameters were monitored: the
retention time and the half-height bandwidth.

4. **UV spectroscopy:** Spectra were obtained at room
25 temperature in BBS or PBS at concentrations of 0.2-1 mg/ ml
on a Philips UV/Vis scanning spectrophotometer Model PU8720
(bandwidth 2 nm) equipped with a printer/plotter. The
spectra were measured in Pye Unicam UV silica cells of 10 mm
path-length. Both the absorption coefficient, i.e., $\epsilon_{1\lambda}$ at
30 the spectrum's λ_{\max} , and the ratio between the absorbances
at λ_{\max} and λ_{\min} were monitored.

5. **Intrinsic fluorescence:** Data were obtained on a
Jasco spectrofluorometer, Model FP-770 at $25^{\circ}\text{C} \pm 0.1^{\circ}\text{C}$.
35 Excitation wavelength was 280 nm and both excitation and
emission slits were set at 5 nm. The concentration of

proteins in the assay was 8-25 $\mu\text{g}/\text{ml}$ in either PBS or fresh BBS, pH 7.5. There is a marked pH dependence of both measured parameters, i.e., λ_{max} (the wavelength of the spectrum's maximum) and the specific intensity (the fluorescence intensity at the spectrum's maximum normalized by the protein concentration in mg/ml).

6. **Amino acid composition:** This test is performed according to the Stein & Moore proven methodology for amino acid analysis. Protein hydrolysis is performed on dried protein following treatment in a Speed Vac centrifuge (Savant): 6.0 N HCl is added, 1 ml per each mg of protein; nitrogen is substituted for air by successive evacuations and rinsing by nitrogen. The tube is sealed and heated for 22 h at $110 \pm 0.1^\circ\text{C}$. The currently used method is essentially in compliance with the USP Drafts of Biotechnology-Derived Products, 1989 USP Convention, Inc.. <954> pp 96-98. The analyzer in use is a Biotronic LC 5000, serial number 515-01. The parameter evaluated by this method is the number of residues of each amino acid, except for Cys and Trp.

7. **Heparin-Sepharose chromatography:** Samples of up to 200 μl were injected onto an analytical Heparin-Sepharose column (5.5 x 0.5 cm), attached to an HPLC system (Waters Associates), consisting of 2 pumps (Model 501), an injector (Model U6K) and an automated gradient controller (Model 580) equipped with a variable wavelength detector - Spectro-Monitor 3000 (LDC/Milton Roy) - and a Chromato-Integrator (Merck-Hitachi, Model 2000). The column was preequilibrated in 10 mM Na-phosphate pH 6.5, 75 mM NaCl at a flow rate of 0.5 ml/min and washed for 5 minutes in the same buffer. The proteins were eluted in a linear gradient from 75 to 500 mM NaCl in buffer in 37.5 minutes. Two parameters were evaluated, the retention time (ret. time), which is proportional to the salt concentration at

which the protein elutes and the half-height band width (half-ht. b.w.), which assesses the peak's homogeneity.

8. **Reverse phase-HPLC chromatography:** Samples were
5 injected onto an analytical Waters C₁₈ Bondapak reverse
phase column (30 x 0.39 cm), attached to an HPLC system as
in Section 1.7. The column was preequilibrated in 80% H₂O,
0.1% TFA/20% acetonitrile, 0.08% TFA at a flow rate of 1
10 ml/min and washed for 5 min with the same solvents. The
proteins were eluted in a linear gradient to 40% H₂O - 0.1%
TFA: 60% acetonitrile - 0.08% TFA in 40 minutes. Two
parameters were evaluated, the retention time (ret. time)
and the half- height band width (half-ht. b.w.), which
assesses the peak's homogeneity.

15

9. **Tryptic maps:** 200 µg samples of the various
batches were digested for 10 min at 37° at various trypsin
w/w ratios, in %: 0.25, 0.5, 1.0, 2.5, 5.0 & 10.0. The
reaction was stopped with 5 mM PMSF, and following 30 min
20 on ice, was treated with sample buffers ±ME (see Sections
1.1.& 1.2.) and run on 20 % acrylamide slab gels - as above.
The degree of equivalence between the band patterns was
assessed after staining with Coomassie Brilliant Blue.

25

10. **Ellman's method for thiol determination in
proteins:** The determination is performed on denatured
proteins, in order to enable full exposure of thiol groups.

30 **Stock solutions:** 1. Guanidine-HCl (of purest quality
available) 7.2 M in 10 mM Tris-HCl, pH 8 (GuCl); 2. DTNB
(Ellman's reagent) 5x10⁻³ M in 100 mM K- phosphate buffer,
pH 7.

35 **Method:** A protein sample containing 10-100 µM of thiol
groups is made up to 0.15 ml; a DTNB blank, (i.e. without

protein included); 0.75 ml of GuCl 7.2 M is added to give a final concentration of 6 M. After incubation for 15-30 minutes at room temperature, the blank of the protein solutions is read at 412 nm. 100 μ l DTNB is then added to
5 a final concentration of 5×10^{-4} M. After incubation for 30 minutes at room temperature, the samples are read at 412 nm versus the DTNB blank. The concentration is calculated using $\epsilon = 13,600 \text{ M}^{-1}\text{cm}^{-1}$, i.e., 100 μ M of thiol groups give an absorbance value of 1.36.

10

11. Precipitation/Adsorption

Eppendorf tubes containing frozen ^{125}I -FBD are allowed to thaw at room temperature, and then mixed by vortexing. Two
15 5 μ l aliquots are removed for radioactivity monitoring. When high specific activity ^{125}I -FBD is used, dilution in siliconized tubes with high salt buffer (0.6 M NaCl- 20 mM, NaHCO_3 pH 8-9) should be carried out before counting. The stock solution is then centrifuged at top speed in an
20 Eppendorf centrifuge and the supernatant removed to another siliconized tube. Two 5 μ l aliquots are counted again. The differences between the radioactivity obtained before and after centrifugation represent the "percent precipitation".

25 When ^{125}I -FBD is kept frozen (at -70°C) in siliconized tubes and in the high salt (0.6 M NaCl) buffer the protein is quite stable. We found only minimal precipitation of ^{125}I -FBD of 0-7% within a period of 2 weeks. However, when kept in non-siliconized tubes and in a low salt (150 mM NaCl)
30 buffer, ^{125}I -FBD precipitation could be as high as to 60-80% in 2-3 days. Under these conditions both precipitation and adsorption to the tube are substantial.

12. Reaction of FBD with ^{14}C -putrescine

35

The reaction measures the accessibility of Gln #3 of the FBD to the transglutaminase reaction of Factor XIIIa).

Method: The reaction mixtures (100 μ l) in siliconized Eppendorf tubes contain: 10 mM CaCl_2 , 50 mM Tris-HCl (pH 7.5), 5 mM DTT, 120 μ M ^{14}C -putrescine (Sigma), 6 μ M FBD and 0.05U/ ml guinea pig liver transglutaminase (Sigma). After incubation at room temperature for 0,15,30 and 60 min, aliquots (10 μ l) are added to tubes containing 200 μ l stop reagent (0.4 mg/ ml BSA, 50 mM EDTA, 150 mM NaCl, 20 mM NaHCO_3 , pH 8.0) at 0°C (on ice). Cold 20% TCA (250 μ l) is added and following 10 min incubation on ice, an additional 3 ml of cold 20% TCA is added and the tube content is filtered on a glass fiber filter (Whatman GF\C). The filters are washed 3 times with cold 20% TCA and once with 70% ethanol. TCA precipitable radioactive material was monitored in a beta counter. The accessibility of Gln #3 in the FBD to transglutamination was calculated based on the specific activity of ^{14}C - putrescine and on the concentration of FBD in the reaction mixture; incorporation of 5% of the total counts is equivalent to 100% accessibility.

13. Self Association

The reaction is carried out in 300 μ l of a 150 mM NaCl-20 mM NaHCO_3 , pH 8.0, containing also: 0.1x Tyrode's buffer; 0.6% BSA; 5 mM CaCl_2 ; 0.15 μ M ^{125}I -FBD; 6 μ l Transglutaminase (0.02U/ ml) - see Section 12.

Reaction mixtures were incubated at 37°C for 18 hours, followed by vacuum aspiration of the reaction solution, washing 3 times with 1 ml "wash buffer" and measuring the radioactivity in a gamma counter.

II. Results

5 All the FBD proteins contain an extra methionine at the amino terminus, and instead of the pyroglutamate residue, which is the blocked N-terminus of the p31 kD (obtained by post-translational modification from the coded Gln), their N-terminal Met is followed by a Gln residue. The positive
10 identification of FBD proteins was also confirmed by Western blot analysis of the gels - developed with anti-20 kD. The 45 kD was identified by developing its blots with both anti-20 kD and anti-33 kD of the cell binding domain.

15 The FBD fragments and the 45 kD FBD-CBD hybrid were further characterized by a variety of: a) physico-chemical tests as described above in comparison to the 31 kD (see Tables C and D).

20 b) biochemical and biological tests in vitro: accessibility of Gln #3 to transglutaminase-catalyzed transamidation (see Tables C and D); and self association. Binding to preformed fibrin clots is described in Example 9.

25 c) biological tests in vivo: binding to venous thrombi in rats is described in Example 13.

Table D details the parameters assayed in the chemical and physico-chemical characterization of FBD polypeptides and of
30 the FBD-CBD hybrid. The 12 kD, 18.5 kD and 45 kD polypeptides were produced by plasmids pFN 203-2, pFN 208-13, and pFN 202-5, respectively.

Table E provides actual measured values for the FBD
35 polypeptides assayed.

Table D. Characterization Parameters for the FBD proteins

METHOD	PARAMETERS
1. SDS-PAGE +ME	molecular weight (cf. markers); purity & homogeneity
2. " -ME	molecular weight (cf. markers); purity & homogeneity
3. Gel filt. (Superose 12)	retention time; half-height bandwidth
4. UV spectroscopy	absorption coeffic.- λ_{\max} -1%; absorbance ratio $\lambda_{\max}/\lambda_{\min}$
5. Intrinsic fluorescence	specific intensity (I/prot. conc.); λ_{\max}
6. Amino acid composition	residue number - equivalence to theoretical value
7. Heparin- Sephrose	retention time; half-height bandwidth
8. RP-HPLC	retention time; half-height bandwidth
9. Ellman	Free thiols.
10. Reaction with ^{14}C -putrescine	Percent of theoretical binding - representing accessibility of Gln #3 to transglutaminase dependent transamidation (<0.5% binding in the absence of the enzyme).

Table E: MEASURED VALUES FOR FBD PROTEINS

PROTEIN	r18.5 kD	r12 kD	r45 kD	r31 kD
1. SDS-PAGE +ME	18.5 kD; ≥98%	14.2 kD; ≥98%	42 kD; ≥90%	31 kD; ≥98%
2. " -ME	17.7 kD; ≥98%	14.4 kD; ≥98%	41 kD; ≥90%	28 kD; ≥98%
3. Gel filt. (Superose 12)	18.29 min; 3mm	19.03 min; 2.5mm	16.56 min; 2mm	17.41 min; 3mm
4. UV spectro- scopy	19.2; 1.84	13.5; 2.02	not done	17.7; 1.55
5. Intrinsic fluorescence	340nm; 10.3	339nm; 14.4	not done	3.43nm; 18.1
6. Amino acid composition	Equivalent to theoretical value	Equivalent to theoretical value	not done	Equivalent to theoretica value

Table E: MEASURED VALUES FOR FBD PROTEINS (Cont'd)

PROTEIN	r18.5 kD	r12 kD	r45 kD	r31 kD
7. Heparin-Sephrose	32.77 min; 8mm	31.14 min; 8mm	34.00 min; 8.5mm	36.50 min; 9mm
8. RP-HPLC	23.02 min; 1mm	21.50 min; 1mm	not done	23.76 min; 2mm
9. Ellman	≤0.2%	≤0.2%	not done	≤1%
10. Reaction with 14C-putrescine	86.0%	100.0%	not done	91%

EXAMPLE 12Directed thrombolysis utilizing FBD-SK complexes

5

I. Introduction

Simple and efficient fibrin-directed thrombolytic agents are a major goal of the pharmaceutical industry. Our approach for the development of such a drug is based on the observation that the N-terminal fibrin binding domain of fibronectin (FBD) can be specifically cross-linked to fibrin clots by Factor XIIIa. Since newly formed thrombi are the only environment which is enriched in activated Factor XIII, FBD may display preferential binding to new over old thrombi and become an ultimate targeting vehicle. We therefore generated, by chemical cross-linking, chimeric FBD-Streptokinase conjugates and analyzed their activity in clot dissolution.

20

Tissue plasminogen activator (TPA) and Streptokinase (SK) are known as the best fibrinolytic agents used in cardiovascular therapy. TPA and SK both degrade fibrin, but they differ in their mode of action. TPA exhibits fibrin - selective plasminogen activation. The selectivity of TPA is due to the presence of fibrin binding sites at the amino terminal region of the molecule. TPA binds to fibrin with a K_d of 0.16 μM . When bound to fibrin, its K_m for the process of plasminogen activation decreases from 83 μM to 0.18 μM resulting in an efficient enzymatic conversion of plasminogen to plasmin.

30

SK interacts with plasminogen to form an activation complex capable of catalyzing the formation of plasmin. This interaction is not dependent on fibrin binding. The activated SK-plasminogen complex in the blood stream may

35

catalyze a systemic conversion of circulating plasminogen to plasmin. The activated plasmin is preferentially inhibited by α_2 -antiplasmin. Once the inhibitor capacity is exhausted, free fibrinogen, fibrin and some other plasma proteins are degraded by plasmin. The resulting fibrinogenolysis causes disruption of the normal coagulation mechanisms, increasing thereby the risk of hemorrhage.

Due to the affinity of TPA to fibrin it is assumed to be advantageous as a fibrinolytic agent relative to SK which does not bind fibrin. TPA and SK were recently compared for their therapeutic efficiency in several large scale human clinical trials. According to the accumulated data SK is the agent of choice for most patients (Scrip No. 1597, pages 22-23, March 8, 1991). A major interest still exists in developing an improved fibrinolytic agent with increased fibrin selectivity. Both chemical cross-linking and recombinant DNA methods are used to design the desired molecules. Several chimeric plasminogen activator molecules have been constructed containing various high affinity fibrin binding domains of several plasma-derived proteins or anti-fibrin monoclonal antibodies bound to the catalytic domain of TPA. These molecules are being analyzed by several pharmaceutical companies for their therapeutic efficacy.

Activated factor XIII (transglutaminase) catalyzes the cross-linking of fibrin molecules in the final step of blood coagulation, thereby increasing the mechanical stability of the clot. As described in Example 6B, intact plasmonic fibronectin (FN) is also cross linked to fibrin by factor XIIIa.

As described in Examples 2 and 4, applicants have cloned and expressed FBD polypeptide fragments of the FN (12 kD, 18.5 kD, 20 kD and 31 kD). These polypeptides have been

studied in vitro and in vivo for their ability to become covalently bound to fibrin clots and thrombi in the presence of factor XIIIa (Example 6, 9, 13). We decided to take advantage of this intrinsic ability of the FBD molecules with respect to their covalent binding to fibrin and to generate by chemical cross-linking (or by recombinant DNA methods) chimeric FBD-SK molecules in order to target SK to the thrombi, thereby reducing the risk of hemorrhage.

10 II. Chemical derivatization and cross-linking of FBD and SK

FBD polypeptides and fragments spanning the amino terminal region of FN were derivatized with N-succinimidyl-3-(2-pyridyldithio) propionate (SPDP) - a heterobifunctional cross-linker.

SPDP reacts at alkaline pH with primary amines introducing 2-pyridyl- disulfide groups into the protein. By measuring the absorbance at 343 nm, which in this pH range is specific for the thio-pyridine group released after the reduction of the modified FBD, the number of cross-linker groups per FBD molecule was calculated. With the plasmatic 31 kD FBD molecule very poor reaction yields were obtained as it tended to precipitate under the conditions of the chemical modification. Further experiments were performed with the recombinant 12 kD FBD molecule produced by plasmid pFN 196-2 (Figure 10). Approximately 2 residues of cross-linker were found to be introduced per each 12 kD FBD molecule.

SK, which lacks cysteine residues was derivatized with 2-iminothiolane. This reagent reacts with primary amines, introducing a charged spacer ending with a thiol group. The number of the thiol groups introduced in the SK molecule was determined by the use of Ellman's reagent. Under the conditions of the modification it was found that about 2 thiol groups were introduced per SK molecule.

By mixing the two derivatized polypeptides the free thiol group will exchange with the 2-pyridyl-sulfide group, forming a disulfide bond between the two proteins and releasing pyridine-2-thiol. Conjugation was found to be optimal at 4 to 8 times molar excess of the derivatized FBD. Under these conditions essentially all derivatized SK molecules had reacted with FBD molecules. The conjugation process was analyzed by SDS-PAGE and by gel filtration on FPLC attached Superose 12. Complex formation was complete in about 10 minutes, yielding a mixture of molecules with variable FBD and SK content.

The chemical modification and cross linking reactions were performed according to Runge et al., PNAS, USA, 84: 7659-7662 (1987).

Under the optimized conditions established for the chemical modification reactions, the calculated number of pyridyl-disulfide and thiol groups on each of the FBD and SK molecules is about 2. The conjugation mixture thus formed contained mostly the desired 1:1 hybrid.

Isolation of the FBD-SK complex

Separation between conjugated and free SK and FBD molecules was carried out in two steps as follows: First, gel filtration on Superose 6 was performed in order to remove excess 12 kD FBD. Second, chromatography on Heparin-Sepharose was used to separate free streptokinase from the conjugate which binds to the resin at 25 mM NaCl, 10 mM Tris/HCl, pH 7.4, and was then eluted with 0.5M NaCl in the same buffer. Contamination by free SK, as judged by gel electrophoresis accounts for less than 5% of the final preparation.

35

Functional characterization of the FBD-SK complex

The cross-linked FBD-SK complex, purified by Heparin-Sepharose chromatography, was compared to native SK using the following criteria:

- 5 1. Kinetics of plasminogen activation using the chromogenic substrate S-2251 of plasmin (Figure 33).
- 10 2. Fibrinolytic activity utilizing the fibrin-plate assay (Figure 34), according to Neville Marsh, Fibrinolysis, 1981.
- 15 3. Human plasma clot lysis, using ^{125}I -fibrinogen, for clot formation.

15

The results indicate that the complex retained a level of plasminogen activator activity comparable to that of SK. From Fig. 33 the apparent K_m values for the plasminogen substrate, K_{plg} , were $3.1 \times 10^{-6}\text{M}$ and $1.8 \times 10^{-6}\text{M}$ for the SK and the FBD-SK complex, respectively, whereas the catalytic rate constant for the complex, k_{plg} , was found to be lower by a factor of 2 than that for SK. Furthermore, Fig. 34 demonstrates no significant difference between the lysis zones formed after overnight incubation by either SK or the
20 FBD-SK complex.
25

In addition, ^{14}C -putrescine was incorporated into the complexes by guinea pig liver transglutaminase to about 40% of the level incorporated into the 12 kD FBD (Figure 35);
30 compare with Table E, Example 11. DTT increased incorporation into the complex up to 140%. No incorporation into SK was observed. These findings indicate that the FBD-SK conjugate has retained the potential of becoming cross-linked to thrombi by activated Factor XIII.

35

Applicants additionally envisage construction of a chimera FBD-SK polypeptide encoded by a recombinant plasmid.

5

EXAMPLE 13

In vivo Labelling of Thrombi by ¹¹¹In-labelled 12 kD and 18.5 kD-FBD in the Rat Stainless-steel Coil Model

10

The model employed is essentially that described in Example 7. Recombinant 12 kD-, 18.5 kD- and 31 kD-FBD polypeptide fragments were labelled with ¹¹¹In by the DTPA method (Example 8). The labelled materials (specific activity approx. 5×10^6 cpm/ μ g) were administered intravenously (5×10^6 cpm/rat) into coil-bearing rats (Example 7) 5h after insertion of the coils. The coils bearing the thrombi were removed and counted 24h after administration of the label. Figure 31 presents the results of the specific radioactivity in the clots and blood, and Figure 32 presents the respective thrombus to blood ratios. As shown, high thrombus specific radioactivity values were obtained with the three compounds. Higher values were found in the thrombi of the 31 kD FBD group, than in those of the 12 kD- and 18.5 kD-FBD fragments. However, the thrombus/blood ratios were higher for the 12 kD and 18.5 kD-FBD fragments, due to lower blood levels, as compared with the 31 kD-FBD. This may be due to the narrow spectrum of specificities and activities of the shorter fragments by comparison with the 31 kD polypeptide (Example 9, Table C).

30

EXAMPLE 14Use of FBD polypeptides in Wound Healing

5 In early events of wound healing the epithelium migrates
over a gel layer of fibrin and fibronectin, before the
permanent basement membrane components, such as laminin and
type IV collagen, are reformed. The initial plasma-derived
10 gel, that contains both fibrin and fibronectin, is readily
invaded by fibroblasts and serves hemostatic and adhesive
functions, providing a provisional matrix for cell migration
and a reservoir of chemotactic and growth factors ("wound
hormones"). The fibrin extravascular gel, which rapidly
15 forms a lattice, incorporates fibronectin. It has been shown
that the fibroblasts *in vivo* attach to the fibrin lattice
primarily via fibronectin (Grinnell, F. et al. (1980) Cell
19 517-525; Colvin, R.B. et. al., (1979) Lab Invest. 41 464-
473; Knox, P. et. al. (1986), J. Cell Biol. 102 2318-2323).
It is therefore believed that the initial processes of wound
20 healing require both the fibrin binding and cell binding
domains of fibronectin. Since the attachment of fibronectin
to fibrin occurs presumably via the transglutaminase -
catalyzed transamidation of Gln-3 of fibronectin to fibrin
lysine residues, any fibrin binding domain polypeptide that
25 contains an intact structure of the region surrounding Gln-3
should be able to act in this system. Thus applicant's 12kD
and 18.5kD polypeptide fragments of the FBD may also be used
together with a CBD polypeptide to enhance wound healing.
Note that recombinant CBD polypeptide may be used, such as
30 the r33kD and r40kD described in copending PCT patent
application No. WO 90/07577.

In order to assess the potential of the FBD of human
fibronectin in promoting wound healing, it was tested in a
35 cell spreading assay. In this assay fibroblasts are allowed
to spread on glass coverslips to which a CBD polypeptide has

been absorbed in the absence or presence of a FBD polypeptide. Thus, the FBD domain polypeptide is tested for its ability to act as an enhancer of cellular focal adhesion, as a co-substrate with fibronectin's cell binding domain. When used in combination with the 75kD cell-binding domain (CBD) derived from bovine plasma fibronectin, the plasma-derived FBD, p31kD, and the recombinant FBD, r31kD, both from human origin, were found to be indistinguishable in their ability to promote focal adhesion of NRK fibroblasts. Both human protein domains were much more effective than the corresponding fragment from bovine origin, when used at the same concentrations, i.e., 100 μ l of 10 μ g/ml of a 1:1 mixture of FBD and CBD proteins (see below for experimental details). The difference between the effects of the 75kD CBD alone and in combination with FBD was striking. Interference reflection microscopy (IRM) of cells spread on the 75kD CBD alone, showed only amorphous 'grey' patches and spots (which, from electron microscopy - EM - of ventral membrane replicates, are known to be associated with clathrin-based structures), but incorporation of FBD (recombinant or plasma-derived) as co-substrate induced formation of clearly-defined focal adhesion structures, visualized in IRM as dense black streaks (the density of color showing closer contact of the ventral surface to the substrate). IRM/EM correlations showed that these tight, ordered adhesions corresponded to the termini of cytoskeletal stress fibers.

For further investigation of the combined effects of the FBD and CBD on wound healing the 45 kD polypeptide (12 kD FBD - 33 kD CBD) and 64 kD polypeptide (31 kD FBD - 33 kD CBD) were constructed (Figures 12 and 25 respectively). Similar hybrid polypeptides are envisaged using 12 kD or 18.5 kD FBD instead of the 31 kD FBD and using the 40 kD CBD polypeptide instead of the 33 kD CBD polypeptide.

Experimental Details

Both the p75kD CBD (from bovine origin) and the 31kD FBD (from recombinant human origin) polypeptides at a concentration of 10 μ g/ml in PBS, total volume 100 μ l, were allowed to adsorb in a humid atmosphere for 1 hour at room temperature to 13mm glass coverslips (Chance Proper Ltd. Warley, UK), which had been treated overnight with conc. H₂SO₄ and rinsed extensively with distilled water. Following washing with PBS pH 7.1 the coverslips were incubated with ovalbumin (1mg/ml in PBS, Sigma Chemical Co.) for 10 min at room temperature in order to reduce non-specific attachment. The spreading assay was performed with NRK cells, subcultured for 18 hours before being detached by 0.1mg/ml TPCK-trypsin (Sigma Chemical Co.) and resuspended in Ca²⁺-containing Eagle's minimum essential medium (EMEM) for 20 min at 37^o. These cells were obtained in a single-cell suspension by gentle sucking into a 5ml syringe fitted with a hypodermic needle, followed by 3 washes with EMEM containing 2% w/v ovalbumin. The spreading of the cells was monitored by resuspending the washed NRK cells on the coverslip with the protein substrate at a density of 1x10⁴ cells/cm². They were examined by interference reflection and phase contrast microscopy, using a Leitz Ortholux II microscope equipped with x50/1.0 and x100/1.32 PHACO RK objectives and photographs were taken (Kodak technical Pan 2415 35mm film). After 2 hours the live cells were fixed with 2.5% v/v glutaraldehyde (TAAB Labs, Reading, Berks, U.K.) in 0.1 M sodium cacodylate buffer and the fixed cells were examined by EM.

EXAMPLE 15: Use of ^{111}In -DTPA modified FBD proteins with high radiochemical purity in order to obtain high thrombus to blood ratios in a rat model.

5

1. Modification and radiolabeling of DTPA-modified FBD proteins

10 The methodology of DTPA modification and the radiolabeling of DTPA-modified FBD proteins described in Example 8 have been improved. These improvements have enabled the obtaining of high thrombus to blood ratios in the coil model in rats.

15 1.1 DTPA-modification: All three recombinant molecules, the r31kD, r18.5 kD and r12kD, were modified with a 20-fold excess of DTPA in 0.1M HEPES buffer pH 7.0, and the excess of DTPA was removed by gel filtration.

20 1.2 Radiolabeling: One of the changes introduced was to perform the radiolabeling with $^{111}\text{InCl}_3$ at a low pH (0.2M citrate buffer, pH 5.7) in order to reduce to a minimum the amount of radiocolloids. An additional precautionary measure was taken to ensure the removal of contaminating heavy metal ions that could displace the chelated ^{111}In from the
25 DTPA-modified protein by exchanging the buffers of the radiolabeled FBD solution with Chelex-100-treated buffers.

30 2. Protocol for modification and radiolabeling of FBD proteins

The detailed improved procedure for the DTPA modification and radiolabeling of the r31 kD, the r18.5 kD and the r12 kD polypeptide fragments of the FBD is given below.

35

2.1. **Desalting:** The proteins (all in 0.5 M NaCl, including millimolar concentrations of EDTA and other protease inhibitors) were desalted and transferred to HEPES buffer (0.1 M pH 7). The 31 kD FBD (27 ml, 0.6 mg/ml) was desalted
5 by dialysis, whereas both the 18.5 kD FBD (5 ml, 8.7 mg/ml) and the 12 kD FBD (5 ml, 5.6 mg/ml) were desalted on PD-10 gel filtration columns.

10 2.2 **DTPA modification:** This was carried out with a 20-fold excess of DTPA anhydride for 1 hour at room temperature in a volume of 27 ml in the case of the 31kD FBD and 7 ml in both the cases of the 12 kD and 18.5 kD FBD proteins. Aliquots (100 μ l) of the modification mixture were set aside
15 for the determination of the number of DTPA residues that had been incorporated into the proteins and the free DTPA was removed from the rest of the material by gel filtration on 2.6x60 cm Sephadex G-25 column, which had been pre-equilibrated and developed with the HEPES buffer. The
20 protein-containing fractions (30 ml) were collected and the protein concentrations obtained were 0.35 mg/ml, 0.8 mg/ml and 0.9 mg/ml for the r31kD, r18.5kD and r12kD FBD proteins, respectively. The degree of modification, which was determined by TLC on silica gel (developed in 85% methanol),
25 was found to be 1.1, 0.8 and 1.6 for the above FBD proteins, respectively. DTPA-modified FBD proteins were stored frozen at -20°C and thawed aliquots gave reproducible results upon radiolabeling with ^{111}In .

30 2.3. **Radiolabeling:** The labeling was carried out with $^{111}\text{InCl}_3$, which had been brought to 0.2 M sodium citrate, pH 5.7, by adding 125 μ l of 1 M sodium citrate pH 5.7 to 500 μ l of the carrier-free $^{111}\text{InCl}_3$ stock solution (^{111}In : 3.2 mCi/ml). The reaction mixture for radiolabeling contained
35 (final concentrations): FBD protein 0.2 μ g/ μ l, HEPES 60 mM, HCl 10 mM, sodium citrate 0.2 M and ^{111}In 0.8 μ Ci/ μ l. The

reaction was allowed to proceed for 1 hr at room temperature. The radiochemical purity was analyzed by TLC on silica gel (developed in 85% methanol) and for all the polypeptide fragments of the FBD it was in the range of 91%-95%. Thus, the specific activity of the radiolabeled FBD proteins is about 3.6 $\mu\text{Ci}/\mu\text{g}$ ($\sim 8 \times 10^6$ cpm/ μg). Since heavy metal ions, potentially present as trace contaminants in the buffers used during radiolabeling, might displace the ^{111}In which is bound to the DTPA-modified FBD proteins, the radiolabeled FBD proteins were passed through a bed of 10ml of Sephadex G-25, which had been pre-equilibrated, and which was developed, with a BSA-containing BBS buffer, which had been pretreated by Chelex-100 (to remove metal ion contaminants).

3. Biological activity

The biological activity was tested with *in vitro* by binding of the ^{111}In -labeled DTPA-modified FBD to preformed clots and *in vivo* in the steel coil-induced venous thrombi model in rats.

3.1 Binding to preformed clots

This was performed exactly as described in Example 6 for iodinated FBD. The specific activity of the three ^{111}In -labeled DTPA-modified FBD proteins was 6×10^6 cpm/ μg protein. Results of the experiments are given in Table F (second column).

3.2 Venous thrombi in rats

The model used (coil-induced venous thrombi in rats) has been described in Example 7. In the experiments of this Example each group consisted of 7 rats to which 5×10^6 cpm (with a specific activity of 6×10^6 cpm/ μg protein) of ^{111}In

labeled DTPA modified FDB protein was injected. Results of the experiments are given in Table F (3 last columns).

Table F: Binding FDB proteins thrombi *in vitro* and *in vivo*

FBD protein	In vitro clot assay Percent of input counts ^a	Venous thrombi in rats		
		Specific radioactivity (cpm/g)		Thrombus to Blood Ratio
		Thrombus	Blood	
r12kD	24%	24264±2700	375±77	78.2±17.3
r18.5kD	26%	28548±5028	289±41	98.3±13.3
r31kD	24%	19796±4144	1198±83	15.6±2.4

^aApproximately 50% of these values are obtained in the presence of iodoacetate, an inhibitor of transglutaminase.

REFERENCES

1. Uehara, A., et al., J. Nuclear Med. 29: 1264-1267 (1988).
2. Zoghbi, S.S., et al., Invest. Radio. 20: 198-202 (1985).
3. Kakkar, V.V., et al., Lancet 1: 540-542 (1970).
4. Knight, L.C., Nuclear Med. Commun. 9: 849-857 (1988).
5. Knight, L.C., Nuclear Med. Commun. 9: 823-829 (1988).
6. Som. P., et al., J. Nuc. Med. 27: 1315-1320 (-1986).
7. Palabrica, T.M., et al., Proc. Nat. Acad. Sci. USA 86: 1036-40 (1989).
8. Akiyama, S.K. and Yamada, K.M., Adv. Enzymol. 57: 1-57 (1987).
9. Pierschbacher, M.D., et al., J. Biol. Chem. 257: 9593-9597 (1982).
10. Pande, H. and Shively, J.E., Arch. Biochem. Biophys. 213: 258-265 (1982).
11. Hayashi, M. and Yamada, K.M., J. Biol. Chem. 258: 3332-3340 (1983).

12. Sekiguchi, K. and Hakomori, S.-I., Proc. Natl. Acad. Sci. USA 77: 2661-2665 (1980).
13. Ruoslahti, E., et al., J. Biol. Chem. 256: 7277-7281 (1981).
14. Owens, R.J. and Baralle, F.E., EMBO J. 5: 2825-2830 (1988).
15. Obara, M., et al., FEBS Letters 213: 261-264 (-1987).
16. Obara, M., et al., Cell 53: 699 (1988).
17. Ichihara-Tanaka, K., et al., J. Biol. Chem. 265: 401-407 (1990).
18. Mandel, et al., Principal and Practice of Infectious Disease 2: 1531-1552 (1979).
19. Proctor, R.A., et al., J. Biol. Chem. 255: 1181-1188 (1980).
20. Eldor, A., et al., Thrombosis and Haemostatis 56(3): 333-339 (1986).
21. Fritzberg, A.R., Nucl. Med. 26: 7-12 (1987).
22. Young, R.A. and Davis, R.W., Proc. Natl. Acad. Sci. USA 80: 1194-1198 (1983).
23. Hugh, T., et al., In DNA Cloning: A Practical Approach (D. Glover, ed.), IRL Press, Oxford (1984).

24. Vogel, et al., Proc. Natl. Acad. Sci. USA 69: 3180-3184 (1972).
25. Bagly, D., et al., Methods in Enzymol. 45: 669-678 (1976).
26. Wagner and Hynes, J. Biol. Chem. 254: 6746-6754 (1979).
27. McDonagh, R.P., et al., FEBS Lett. 127: 174-178 (1981).
28. Mosher, et al., J. Biol. Chem. 255: 1181-1188 (1980).
29. Russel, P.B., et al., J. Clin. Micro. 25: 1083-1087 (1987).
30. Bolton, A.E. and Hunter, W.M., Biochem. J. 133: 529 (1973).
31. Obara, et al., Cell 53: 649-657 (1988).
32. Fritzberg, A.R., et al., Proc. Natl. Acad. Sci. 85: 4025-4029 (1988).
33. Knight, L.C., et al., Radiology 173: 163-169 (-1989).
34. Wasser, M.N.J.M., et al., Blood 74: 708-714 (-1989).
35. Burger, J.J., et al., Methods in Enzymology 112: 43-56 (1985)

36. Yamamoto, K., et al., Eur. J. Nucl. Med. 14: 60-64 (1988).
37. Peterson, et al., in Fibronectin, edited by Moshen, Academic Press, USA, 1989: page 1-24, particularly Figure 2 on page 5.

What is claimed is:

1. An imaging agent which comprises a polypeptide labeled with an imageable marker, such polypeptide having an amino acid sequence substantially identical to a sequence present in the fibrin binding domain of naturally-occurring human fibronectin, being capable of binding to fibrin, having a molecular weight above about 6 kD but less than about 20 kD, and having the amino acid sequence gln-ala-gln-gln or met-gln-ala-gln-gln at the N-terminus of the polypeptide.
2. An imaging agent of claim 1, wherein the polypeptide additionally has those intramolecular disulfide bonds present in naturally-occurring human fibronectin which are necessary for fibrin binding.
3. An imaging agent of claim 1, wherein the polypeptide has a molecular weight of about 12 kD or above.
4. An imaging agent of claim 1, wherein the polypeptide has a molecular weight of about 20 kD or below.
5. An imaging agent of claim 1, wherein the polypeptide has a molecular weight of about 18.5 kD or below.
6. A composition comprising an effective imaging amount of the imaging agent of claim 1 and a physiologically acceptable carrier.

7. An agent of claim 1, wherein the marker is a radioactive isotope, an element which is opaque to X-rays, or a paramagnetic ion.
8. An agent of claim 7, wherein the marker is a radioactive isotope.
9. An agent of claim 8, wherein the radioactive isotope is indium-111.
10. An agent of claim 8, wherein the radioactive isotope is technetium-99m.
11. An agent of claim 8, wherein the radioactive isotope is iodine-123, iodine-125, iodine-131, krypton-81m, xenon-133, or gallium-67.
12. An agent of claim 1, wherein the polypeptide comprises a 20 kD polypeptide wherein the amino acid sequence substantially identical to a sequence present in the fibrin binding domain of human fibronectin is the amino acid sequence of amino acids 1-153 as shown in Figure 2.
13. An agent of claim 12, wherein the polypeptide comprises less than about 20 additional amino acids.
14. An agent of claim 1, wherein the polypeptide is a 12 kD polypeptide wherein the amino acid sequence substantially identical to a sequence present in the fibrin binding domain of human fibronectin is the sequence of amino acids 1-109 as shown in Figure 2.

15. An agent of claim 1, wherein the polypeptide is an 18.5 kD polypeptide wherein the amino acid sequence substantially identical to a sequence present in the fibrin binding domain of human fibronectin is the sequence of amino acids 1-154 as shown in Figure 2.
16. A method for imaging a fibrin-containing substance which comprises contacting the fibrin-containing substance to be imaged with the agent of claim 1 under conditions such that the agent binds to the fibrin-containing substance and imaging bound agent and thereby imaging the fibrin-containing substance.
17. A method of claim 16, wherein the fibrin-containing substance is a thrombus.
18. A method of claim 16, wherein the fibrin-containing substance is atherosclerotic plaque.
19. A method for imaging a fibrin-containing substance in a subject which comprises:
 - (a) administering to the subject a composition of claim 6 under conditions permitting the imaging agent contained therein to enter the blood stream and bind to fibrin present in the blood vessels;
 - (b) imaging bound agent within the blood vessels; and thereby
 - (c) imaging the fibrin-containing substance.

20. A method of claim 19, wherein the fibrin-containing substance is a thrombus.
21. A method of claim 19, wherein the fibrin-containing substance is atherosclerotic plaque.
22. A method of claim 16, wherein the polypeptide is an 18.5 kD polypeptide wherein the amino acid sequence substantially identical to a sequence present in the fibrin binding domain of human fibronectin is the sequence of amino acids 1-154 as shown in Figure 2.
23. A method of claim 16, wherein the polypeptide comprises a 20 kD polypeptide wherein the amino acid sequence substantially identical to a sequence present in the fibrin binding domain of human fibronectin is the sequence of amino acids 1-153 as shown in Figure 2.
24. A method of claim 23, wherein the polypeptide comprises less than about 20 additional amino acids.
25. A method of claim 16, wherein the polypeptide is a 12 kD polypeptide wherein the amino acid sequence substantially identical to a sequence present in the fibrin binding domain of human fibronectin is the sequence of amino acids 1-109 as shown in Figure 2.
26. A method of claim 16, wherein the marker is a radioactive isotope, an element which is opaque to X-rays, or a paramagnetic ion.

27. A method of claim 16, wherein the imaging is carried out using a gamma camera.
28. A plasmid for expression of a polypeptide having an amino acid sequence substantially present in the fibrin binding domain of naturally-occurring human fibronectin, being capable of binding to fibrin, having a molecular weight above about 6 kD but less than about 20 kD, and having the amino acid sequence gln-ala-gln-gln or met-gln-ala-gln-gln at the N-terminus of the polypeptide comprising DNA encoding the polypeptide and DNA encoding suitable regulatory elements positioned relative to the DNA encoding the polypeptide so as to effect expression of the polypeptide in a suitable host cell.
29. A plasmid of claim 28, wherein the polypeptide is about an 18.5 kD polypeptide corresponding to an amino acid sequence present in the fibrin binding domain of human fibronectin.
30. A plasmid of claim 28, wherein the polypeptide comprises about a 20 kD polypeptide corresponding to an amino acid sequence present in the fibrin binding domain of human fibronectin.
31. A plasmid of claim 28, wherein the polypeptide is about a 12 kD polypeptide corresponding to an amino acid sequence present in the fibrin binding domain of human fibronectin.
32. A plasmid of claim 29, wherein the amino acid sequence present in the fibrin binding domain of human fibronectin comprises amino acids 1-154 as shown in Figure 2.

23. A plasmid of claim 30, wherein the amino acid sequence present in the fibrin binding domain of human fibronectin comprises amino acids 1-153 as shown in Figure 2.
34. A plasmid of claim 33, wherein the polypeptide comprises less than about 20 additional amino acids.
35. A plasmid of claim 31, wherein the amino acid sequence present in the fibrin binding domain of human fibronectin comprises the amino acid sequence of amino acids 1-109 as shown in Figure 2.
36. A plasmid according to claim 34 designated pFN 949-2 and deposited in Escherichia coli strain A1645 under ATCC Accession No. 67831.
37. A plasmid according to claim 35 designated pFN 196-2 and deposited in Escherichia coli strain A4255 under ATCC Accession No. 68328.
38. A plasmid according to claim 35 designated pFN 203-2 and deposited in Escherichia coli strain A4255 under ATCC Accession No. 68606.
39. A cell which comprises the plasmid of claim 28.
40. A bacterial cell according to claim 39.
41. An Escherichia coli cell according to claim 40.
42. An Escherichia coli cell according to claim 41, wherein the plasmid is designated pFN 949-2 and

wherein the cell is deposited under ATCC Accession No. 67831.

43. An Escherichia coli cell according to claim 41, wherein the plasmid is designated pFN 196-2 and wherein the cell is deposited under ATCC Accession No. 68328.
44. A method of producing a polypeptide having an amino acid sequence substantially present in the fibrin binding domain of naturally-occurring human fibronectin and being capable of binding to fibrin which comprises treating the cell according to claim 39 so that the DNA directs expression of the polypeptide and the cell expresses the polypeptide and recovering from the cell the polypeptide so expressed.
45. A method of producing a 20 kD polypeptide fragment corresponding to an amino acid sequence present in the fibrin binding domain of naturally-occurring human fibronectin which comprises treating an Escherichia coli cell comprising the plasmid of claim 33 so that the DNA directs expression of the polypeptide and the cell expresses the polypeptide and recovering from the cell the polypeptide so expressed.
46. A method of producing a 12 kD polypeptide fragment corresponding to an amino acid sequence present in the fibrin binding domain of naturally-occurring human fibronectin which comprises treating an Escherichia coli cell comprising the plasmid of claim 35 so that the DNA directs expression of the polypeptide and the

cell expresses the polypeptide and recovering from the cell the polypeptide so expressed.

47. A purified polypeptide capable of binding fibrin, substantially free of other substances of human origin, having an amino acid sequence present in the amino terminal fibrin binding domain of naturally occurring human fibronectin, having a molecular weight above about 6 kd but less than about 20 kd and having the amino acid sequence gln-ala-gln-gln or met-gln-ala-gln-gln at the N-terminus of the polypeptide.
48. A polypeptide of claim 47, wherein the polypeptide comprises a 20 kd polypeptide having the amino acid sequence of amino acids 1-153 as shown in Figure 2.
49. A polypeptide of claim 48, wherein the polypeptide comprises less than about 20 additional amino acids.
50. A polypeptide of claim 47, wherein the polypeptide is a 12 kd polypeptide having the amino acid sequence of amino acids 1-109 as shown in Figure 2.
51. A polypeptide of claim 47, wherein the polypeptide is an 18.5 kd polypeptide corresponding to an amino acid sequence present

SUBSTITUTE SHEET
IPEA/US



in the fibrin binding domain of human fibronectin, having the amino acid sequence of amino acids 1-154 as shown in Figure 2 and having the amino acid sequence gln-ala-gln-gln or met-gln-ala-gln-gln at the N-terminus of the polypeptide.

52. A polypeptide of claim 47 fused to a second polypeptide which comprises a portion of the amino acid sequence of the cell binding domain of naturally-occurring human fibronectin having cell binding activity.
53. A 45 kD fused polypeptide of claim 52, wherein the polypeptide is a 12 kD polypeptide and the second polypeptide is a 33 kD polypeptide.
54. A polypeptide of claim 47, wherein the amino acid sequence DGRGDS is fused to the N-terminus of the polypeptide.
55. A 64 kD fused polypeptide of claim 52, wherein the polypeptide is a 31 kD polypeptide and the second polypeptide is a 33 kD polypeptide.
56. A plasmid for expression of the 45 kD fused polypeptide of claim 53 designated pFN 202-5.
57. A plasmid for expression of the polypeptide of claim 54 designated pFN 195-4.
58. A plasmid for expression of the 64 kD fused polypeptide of claim 55 designated pFN 194-2.
59. A method of refolding the polypeptide of claim 47 and wherein the polypeptide may optionally be fused to a second polypeptide of 33 kD molecular

SUBSTITUTE SHEET
IPEA/US



weight comprised of a substantial portion of the cell binding domain of fibronectin having cell binding activity which comprises contacting the polypeptide with a thiol-containing compound and a disulfide so as to refold and reoxidize the polypeptide.

60. A method of claim 59, wherein the thiol-containing compound is selected from the group consisting of glutathione, thioredoxin, β -mercaptoethanol, and cysteine.
61. A method of claim 59, wherein the thiol-containing compound is β -mercaptoethanol and the disulfide is produced in situ by introduction of air.
62. A method of claim 59, wherein the polypeptide is selected from the group consisting of an 18.5 kD polypeptide, a 20 kD polypeptide, a 12 kD polypeptide and a 45 kD polypeptide.
63. A method of claim 59, which additionally comprises contacting the polypeptide with a denaturant.
64. A method of claim 63, wherein the denaturant is guanidine hydrochloride or urea.
65. A method of claim 59, wherein the polypeptide is at a low concentration.
66. A method of claim 65, wherein the concentration is below 1,000 $\mu\text{g/ml}$.

SUBSTITUTE SHEET
IPEA/US



67. A method for recovering a purified, biologically active polypeptide having an amino acid sequence substantially present in the fibrin binding domain of naturally-occurring human fibronectin, being capable of binding to fibrin, having a molecular weight of about 6 Kd but less than 20 Kd, and having the amino acid
5 sequence gln-ala-gln-gln or met-gln-ala-gln-gln at the N terminus of the polypeptide, which comprises:

- 10 (a) producing in a bacterial cell by means of expression of a plasmid containing DNA encoding the polypeptide a first polypeptide having the amino acid sequence of the polypeptide but lacking the disulfide bond;
- (b) disrupting the cell so as to produce a lysate containing the first polypeptide;
- (c) centrifuging the lysate so as to concentrate the first polypeptide;
- 15 (d) separating the concentrated first polypeptide;
- (e) solubilizing the separated, concentrated first polypeptide;
- 20 (f) refolding and reoxidizing the solubilized first polypeptide so as to form the biologically active polypeptide;
- (g) separating the refolded and reoxidized biologically active polypeptide;
- 25 (h) recovering the purified, refolded and reoxidized biologically active polypeptide; and
- (i) purifying the biologically active polypeptide so recovered.



68. A method of claim 67, wherein the refolding and reoxidizing comprises contacting the polypeptide with a thiol-containing compound and a disulfide so as to refold and reoxidize the polypeptide.
69. A method of claim 68, wherein the thiol-containing compound is selected from the group consisting of glutathione, thioredoxin, β -mercaptoethanol, and cysteine.
70. A method of claim 68, wherein the thiol-containing compound is β -mercaptoethanol and the disulfide is produced in situ by introduction of air.
71. A method of claim 67, wherein the polypeptide is selected from the group consisting of an 18.5 kD polypeptide, a 20 kD polypeptide, a 12 kD polypeptide and a 45 kD polypeptide.
72. A method of claim 68, which additionally comprises contacting the polypeptide with a denaturant.
73. A method of claim 72, wherein the denaturant is guanidine hydrochloride or urea.
74. A method of claim 68, wherein the polypeptide is at a low concentration.
75. A method of claim 74, wherein the concentration is below 1,000 $\mu\text{g/ml}$.
76. A method of claim 67, wherein the separating of the concentrated first polypeptide in step (d) comprises chromatography.

77. A method of claim 76, wherein the chromatography comprises Heparin-Sepharose chromatography.
78. A method of inhibiting thrombus formation in a subject susceptible to thrombus formation which comprises administering to the subject an amount of a polypeptide of claim 47 effective to inhibit thrombus formation.
79. A method of inhibiting thrombus formation in a subject susceptible to thrombus formation which comprises administering to the subject an amount of a fused polypeptide of claim 52 effective to inhibit thrombus formation.
80. A polypeptide in accordance with claim 47 bound to a thrombolytic agent.
81. A polypeptide bound to a thrombolytic agent in accordance with claim 80, wherein the thrombolytic agent is selected from the group consisting of: tissue plasminogen activator (TPA), urokinase, streptokinase, prourokinase, Anisoylated Plasminogen-Streptokinase Activator Complex (EminaseTM), TPA analogs, or a protease.
82. A polypeptide of claim 81, wherein the polypeptide has an amino acid sequence substantially present in the fibrin binding domain of naturally-occurring human fibronectin, is capable of binding to fibrin, has a molecular weight above about 6 kD but less than about 20 kD, has the amino acid sequence gln-ala-gln-gln or met-gln-ala-gln-gln at the N-terminus of the polypeptide and wherein the thrombolytic agent is streptokinase.

83. A polypeptide of claim 81, wherein the polypeptide is a 12 kD polypeptide and the thrombolytic agent is streptokinase.
84. A method for achieving thrombolysis of a thrombus which comprises administering to a subject an amount of the polypeptide of claim 80 effective to achieve thrombolysis.
85. A method of treating a subject with a wound which comprises administering to the subject an amount of the purified polypeptide of claim 47 in conjunction with a polypeptide which comprises a substantial portion of the cell binding domain of naturally-occurring human fibronectin effective to treat the wound.
86. A method of claim 85 wherein the cell binding domain of naturally-occurring human fibronectin is a 40 kD polypeptide or a 33 kD polypeptide.
87. A method of treating a subject with a wound which comprises administering to the subject an amount of the fused polypeptide of claim 52 effective to treat the subject.
88. A method of claim 87 wherein the fused polypeptide is a 45 kD polypeptide, wherein the polypeptide is a 12 kD polypeptide and the second polypeptide is a 33 kD polypeptide.
89. A method of claim 87 wherein the fused polypeptide is a 64 kD fused polypeptide, wherein the polypeptide is a 31 kD polypeptide and the second polypeptide is a 33 kD polypeptide.

90. A method of treating a subject in accordance with claim 85 or 87, wherein the wound is a cutaneous wound.
91. A method of treating a subject in accordance with claim 90, wherein the cutaneous wound is an incisional wound, a skin deficit wound, a skin graft wound, or a burn wound.
92. A method of treating a subject in accordance with claim 85 or 87, wherein the wound is an eye wound.
93. A method of treating a subject in accordance with claim 92, wherein the eye wound is a corneal epithelial wound or a corneal stromal wound.
94. A method of treating a subject in accordance with claim 85 or 87, wherein the wound is a tendon injury.

Figure 1

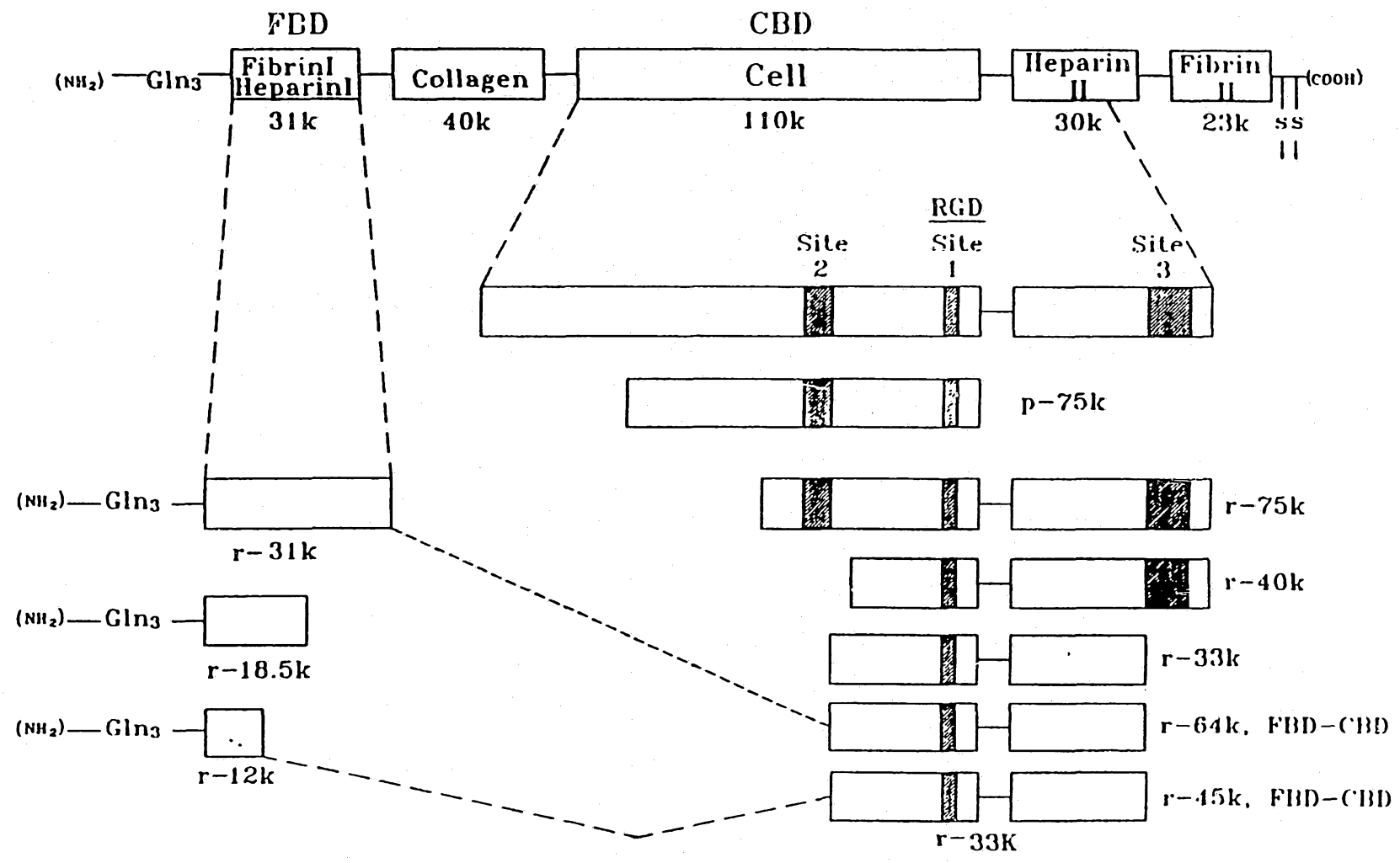

1/43

Figure 2A

FIRST SEQ. NO. =

¹ S K R O A O O M V O P O S P V A V S O S K P G ² C Y D N G K H Y Q I N O O W E R
 GAAGAGCAAGAGGCAGGCTCAGCAAAATGGTTCAGCCOCAGTCCOCGGTGGCTGTCAAGTCAAGCAAGCCCGGTTGTTATGACAATGGAAAACACTATCAGATAAATCAACAGTGGGAGCG
 10 20 30 40 50 60 70 80 90 100 110 120
 T Y L G M V L V C T C Y G G S R G F N C E S K P E A E E T C ³ F D K Y T G N T Y R
 GACCTACCTAGGTAATGTGTTGGTTGTACTTGTATGAGGAAOCCGAGGTTTTAACTOOGAAAGTAAAOCTGAAGCTGAAGAGACTTGCTTTGACAAGTACACTGGGAACACTTACCG
 130 140 150 160 170 180 190 200 210 220 230 240
 V G D T Y E R P K D S M I W D C T C I G A G R R G R I S C T I A N R C H E G G O S ⁴
 AGTGGGTGACACTTATGAGCGTCTAAAGACTCCATGATCTGGGACTGTAOCTGCATCGGGCTGGCGGAGGAGAATAAGCTGTACCATGGCAAACCGCTGCCATGAAGCGGGTCAAGTC
 250 260 270 280 290 300 310 320 330 340 350 360
 Y K I G D T W R R P H E T G G Y M L E C V C L G M G K G E W T C K P I A E K C F ⁵
 CTACAAGATTGGTGACAOCCTGGAGGAGACCACATGAGACTGGTGGTTACATGTTAGAGTGTGTGTCTTGGTAATGGAAAAGAGAATGGAOCTGCAAGCCATAGCTGAGAAGTGT
 370 380 390 400 410 420 430 440 450 460 470 480
 D H A A G T S Y V V G E T W E K P Y O G W M M V D C T C L G E G S G R I T C T S
 TGATCATGCTGCTGGGACTCCATATGTGGTCCGAGAAOCTGGGAGAAOCCCTACCAAGCTGGATGATGGTAGATTGTACTTGCCTGGGAGAAOCCGAOCCATCACTTGCCTTC
 490 500 510 520 530 540 550 560 570 580 590 600
 R N R C N D O D T R T S Y R I G D T W S K K D N R G N L L O C I C T G M G R G E ⁶
 TAGAAATAGATGCAACGATCAGGACACAAGGACATCCTATAGAATTTGAGACAOCCTGGAGCAAGAAAGATAATGGAGAAAOCTGCTCCAGTGCATCTGCACAAGCAACOGGAGGAGA
 610 620 630 640 650 660 670 680 690 700 710 720
 W K C E R H T S V Q T T S S G S G P F T D V R A A V Y O P Q P H P O P P P Y C H ⁷
 GTGGAAGTGTGAGAGGCACAOCTCTGTGCAGACCACATCGAGCCGATCTGGCCOCTTCAOOGATGTTCTGTGCAGCTGTTTACCAAOCCGAGCCTCAOCCOCCAGCCTCCTCCCTATCGCCA
 730 740 750 760 770 780 790 800 810 820 830 840
 C V T D S G V V Y S V G M O W L K T O G N K Q M L C T C L G N G V S C O E T A Y ⁸
 CTGTGTACAGACAGTGGTGTGGTCTACTCTGTGGGATGCAGTGGTTGAAGACACAAGAAATAGCAAATGCTTTGCACGTGCCOCCGAACCGAGTCAGCTGCCAAGAGACAGCTGT
 850 860 870 880 890 900 910 920 930 940 950 960 ⁹

SUBSTITUTE SHEET

2/43

Figure 2B

SUBSTITUTE SHEET

T O T Y G G N L N G E P C V L P F T Y N G R T F F Y S C T T E G R O D G H L W C S
 AACCCAGACTTACCGTGGCAACTTAAATGGAGAGCCATGTGTCTTAACCAITTCACCTACAATGGCAOGACGTTCTACTCCTGCCACCACGGAAGGGGACAGGACGGACATCTTTGSTGCAG
 970 980 990 1000 1010 1020 1030 1040 1050 1060 1070 1080

¹⁰
 T T S N Y E O D O K Y S F C T D H T V L V O T O G G N S N G A L C H F P F L Y N
 CACAACCTTGAATTATGAGCAGGAACAGAAATACTCTTTCTGCACAGACCACACTGTTTTGGTTGAGACTCAAGGAGGAAATCCAAATGGTGGCTTGTGCCACTTCCCTTCTATACAA
 1090 1100 1110 1120 1130 1140 1150 1160 1170 1180 1190 1200

N H N Y T D C T S E G R R D N M K W C G T T O N Y D A D O K F G F C P M A A H E
 CAACACAATTACACTGATTGCACTTCTGAGGGCAGAAGAGACAACATGAAGTGGTGTGGGACACAGAACTATGATGCGGACAGAAAGTTGGGTTCTGCCCATGGCTGCCACGA
 1210 1220 1230 1240 1250 1260 1270 1280 1290 1300 1310 1320

¹¹
 E I C T T N E G V M Y R I G D Q W D K O H D M G H M M R C T C V G N G R G E W T
 GGAAATCTGCCACAACCAATGAAGGGTCAATGTACCGCATTGGAGATCAGTGGGATAGCAGCATGACATGGGTGACATGATGAGGTGCACGTGTGTTGGGAATGGTCGGGGAATGGAC
 1330 1340 1350 1360 1370 1380 1390 1400 1410 1420 1430 1440

¹²
 C I A Y S O L R D O C I Y D D I T Y N V N D T F H K R H E E G H M L N C T C F G
 ATGCATTGCCACTGCAACTTGGAGATCAGTGCATTGTTGATGACATCACTTACAATGTGAAGACACATTCACAAAGCGTCATGAAGAGGGGCACATGCTGAACTGTACATGCTTGG
 1450 1460 1470 1480 1490 1500 1510 1520 1530 1540 1550 1560

¹³
 Q G R G R W K C D P V D O C O D S E T G T F Y O I G D S W E K Y V H G V R Y O C
 TCAGGGTGGGGCAGGTGGAAGTGTGATCCCGTGGACCAATGGCAGGATTGAGAGACTGGGACGTTTTATCAAATGGAGATTCAATGGGAGAAGTATGTGCATGGTGTGAGATACCAC TG
 1570 1580 1590 1600 1610 1620 1630 1640 1650 1660 1670 1680

¹⁴
 Y C Y G R G I G E W H C O P L O Y Y P S S S G P V E V F I T E T P S O P N S H P
 CTACTGCTATGGCGTGGCATTGGGAGTGGCATTGCCAAOCTTTACAGAOCCTATCCAAGCTCAAGTGGTGGTGTGCAAGTATTTATCACTGAGACTCCGAGTCAGGCCAACTOCCACCC
 1690 1700 1710 1720 1730 1740 1750 1760 1770 1780 1790 1800

I O N A P O P S H I S K Y I L R W R P K N S V G R W K E A T I P G H L N S Y T
 CATCCAGTGGAAATGCACCACAGCCATCTCACATTTCCAAGTACATCTCAGGTGGAGACCTAAAAATCTGTAGCGCGTGGAAAGGCTAOCATACCAOCCACTTAACTCCTACAC
 1810 1820 1830 1840 1850 1860 1870 1880 1890 1900 1910 2000

Figure 2C

SUBSTITUTE SHEET

15

I K G L K P G V V Y E G Q L I S I O O Y G H O E V T R F D F T T T S T S T P V T
 CATCAAAGGDOCTGAAGDOCTGGTGTGGTATAAGGAGGGOCAGCTCATCAGCATCCAGCAGTACGGOCAACCAAGAGTGACTGGCTTTGACTTCAOCCACCAOCCAGCACCAGCACAOCTGTGAC
 1930 1940 1950 1960 1970 1980 1990 2000 2010 2020 2030 2040

16

S N T V T G E T T P F S P L V A T S E S V T E I T A S S F Y V S W V S A S D T Y
 CAGCAACACOGTGACAGSAGAGACGACTOCCTTTTCTOCTCTGTGGOCACCTTCTGAATCTGTGAOOGAAATCACAGCCAGTAGCTTTGTGGTCTOCTGGGTCTCAGCTTOCGACAOCT
 2050 2060 2070 2080 2090 2100 2110 2120 2130 2140 2150 2160

S G F R V E Y E L S E E G D E P O Y L D L P S T A T S V M I P D L L P G R K Y I
 GTCGGGATTCOOGGTGGAATATGAGCTGAGTGAGGAGGGAGATGAGCCACAGTAOCTGGATCTTCCAAGCACAGCCACTTCTGTGAACATCOCTGAOCTTGCTTCTCTGGCCAAAATACAT
 2170 2180 2190 2200 2210 2220 2230 2240 2250 2260 2270 2280

17

V N V Y Q I S E D G E Q S L I L S T S O T T A P D A P P D P T V D Q V D D T S I
 TGTAATGTCTATCAGATATCTGAGGATGGGAGCAGAGTTTGATOCTGTCTACTTCACAAACACAGOGDOCTGATCOOCTOCTGAOCCGACTGTGGADCAAGTTGATGACACCTCAAT
 2290 2300 2310 2320 2330 2340 2350 2360 2370 2380 2390 2400

V V R M S R P O A P I T G Y R I V Y S P S V E G S S T E L N L P E T A N S V T L
 TGTGTTGGCTGGAGCAGACOOCCAGGCTOCCATCACAGGSTACAGAAATAGTCTATTOGOCATCAGTAGAAGGTAGCAGCACAGAACTCAACCTTCTGAAACTGCAAACTOCCGTCAOCCCT
 2410 2420 2430 2440 2450 2460 2470 2480 2490 2500 2510 2520

18

S D L Q P G V Q Y N I T I Y A V E E N Q E S T P V V I Q Q E T T G T P R S D T Y
 CAGTGACTTGCAAOCTGGTGTTCAGTATAACATCACTATCTATGCTGTGGAAGAAAATCAAGAAAGTACAOCCTGTTGTCAITCAACAAGAAOCCACTGGCAOCCOCCAGCTCAGATACAGT
 2530 2540 2550 2560 2570 2580 2590 2600 2610 2620 2630 2640

P S P R D L Q F V E V T D V K V T I M W T P P E S A V T G Y R V D V I P V N L P
 GCOOCTCTCCAGGGACCTGCAGTTTGTGGAAGTGACAGAGGTGAAGGTACCATCATGTGGACAODGDOCTGAGAGTGCAGTGAOCCGCTAOCCTGTGGATGTGAATCOOCCGTCAACCTGCC
 2650 2660 2670 2680 2690 2700 2710 2720 2730 2740 2750 2760

G E H G Q R L P I S R N T F A E V T G L S P G V T Y Y F K V F A V S H G R E S K
 TGCCGAGCAOCCOCCAGAGGCTGOCCATCAGCAGAAACAOCTTTGCAGAAGTCAOCCGGCTGTCCOCTGGGGTCACTTACTTCAAAGTCTTTGCAGTGAGCCATGGGAGGAGAGCAA
 2770 2780 2790 2800 2810 2820 2830 2840 2850 2860 2870 2880

4/43

Figure 2D

SUBSTITUTE SHEET

5/43

19
 P L T A Q Q T T K L S A P T M L O F V N E T D S T V L V R W T P P R A O I T G Y
 GCCTCTGACTGCTCAACAGACAACCAAACTGGATGCTOCCACTAACTOCAGTTTGTCAATGAACTGATTTCTACTGTCTGGTGAGATGGACTCCACTCGGGGOCAGATAACAGGATA
 2890 2900 2910 2920 2930 2940 2950 2960 2970 2980 2990 3000

R L T V G L T R R G O P R O Y N V G P S V S K Y P L R N L O P A S E Y T V S L V
 CCGACTGAOZGTGGGCTTAAOCCGAGAGGGCCAGCCAGTACAATGTGGTCCCTCTGTCTTCAAGTACODCCGAGGAATCTGCAGCTGCATCTGAGTACACCGTATCCCTCGT
 3010 3020 3030 3040 3050 3060 3070 3080 3090 3100 3110 3120

20
 A I K G N O E S P K A T G V F T T L O P G S S I P P Y N T E V T E T T I V I T W
 GGCCATAAAGGGCAACCAAGAGAGODCCAAAGCCACTGGAGTCTTTAACCACACTGCAGCTGGAGCTCTATTOCAOCTTACAACAODGAGGTGACTGAGACCACCATCGTGATCAGATG
 3130 3140 3150 3160 3170 3180 3190 3200 3210 3220 3230 3240

T P A P R I G F K L G V R P S O G G E A P R E V T S O S G S I V V S G L T P G V
 GAOQOCTOCTOCAAGAATTGGTTTTAAGCTGGGTGAOGAOCCAGOCAGGGAGGAGAGGCCAOCCAGAGAAGTGACTTCAGACTCAGGAAGCATEGTTGTGTCCOCTTGACTCCAGGAGT
 3250 3260 3270 3280 3290 3300 3310 3320 3330 3340 3350 3360

21
 E Y V Y T I O V L R D G O E R D A P I V N K V Y T P L S P P T M L H L E A N P D
 AGAATAOCTCTACACCATCCAAGTCCGAGAGATGGACAGGAAGAGATGGCCAAATTGTAACAAAGTGGTGACACCATGTCTOCCAACAACAACTTGCACTCGAGGGCAACCCCTGA
 3370 3380 3390 3400 3410 3420 3430 3440 3450 3460 3470 3480

T G V L T V S M E R S T T P D I T G Y R I T T T P T N G O O G N S L E E V V H A
 CACTGGAGTGCTCACAGTCTOCTGGGAGAAGGAGCAOCCAOCCAGACATTACTGGTTATAGAAATTAACCACAACCCCTACAACCGCCAGCAGGGAAATTTCTTTGGAAGAAGTGGTCCATGC
 3490 3500 3510 3520 3530 3540 3550 3560 3570 3580 3590 3600

22
 D O S S C T F D N L S P G L E Y N V S V Y T V K D D K E S V P I S D T I I P A V
 TGATCAGAGCTOCTGCACCTTTTGATAOCTGAGTCCOCCOCTGGAGTACAATGTGAGTGTTTACTGTCAAGGATGACAAGGAAAGTGTCCCTATCTCTGATACCATCATCCAGCTGT
 3610 3620 3630 3640 3650 3660 3670 3680 3690 3700 3710 3720

P P P T D L R F T N I G P O T M R V T W A P P P S I O L T N F L V R Y S P V K H
 TCCTOCTOCCACTGAOCTGGATTCACCAACATTTGTCAGACACCATGCGTGTCAOCTOCCCTCCACCCCATOCATTTGATTTAOCACACTTCTGGTCCGTTACTCACCTGTGAAAAA
 3730 3740 3750 3760 3770 3780 3790 3800 3810 3820 3830 3840

Figure 2E

SUBSTITUTE SHEET

E E D V A E L S I S P S D N A V V L T N L L P G T E Y V V S V S S V Y E O H E S
 TGAGGAAGATGTTGCAGAGTTGTCAATTTCTCCTTCAGACAATGCAGTGGTCTTAACAAATCTOCTGCOCTGGTACAGAATATGTAGTGAGTGTCTOCAGTGTCTAOGAACAAACATGAGAG
 3850 3860 3870 3880 3890 3900 3910 3920 3930 3940 3950 3960

23
 T P L R G R O K T G L D S P T G I D F S D I T A N S F T V H W I A P R A T I T G
 CACAOCTCTTAGAGGAAGACAGAAAACAGGTCTTGATTCCCAACTGGCATTGACTTCTCTGATATTACTGGCAACTCTTTTACTGTGCACTGGATTGCTCCTCGAGCCACCATCACTGG
 3970 3980 3990 4000 4010 4020 4030 4040 4050 4060 4070 4080

Y R I R H H P E H F S G R P R E D R V P H S R M S I T L T N L T P G T E Y V V S
 CTACAGGATCCGOCATCATOCCGAGCACTTCAGTGGGAGAAGCTOGAGAAGATCGGGTGCCCACTCTCGGAATTOCATCACCCCTCAOCCAAOCTCACTOCCAGGCACAGAGTATGTGGTCAG
 4090 4100 4110 4120 4130 4140 4150 4160 4170 4180 4190 4200

24
 I V A L N G R E E S P L L I G O O S T V S D V P R D L E V V A A T P T S L L I S
 CATCGTTGCTCTTAATGGCAGAGAGGAAAGTCCCTTATTGATTGGCAACAATCAACAGTTTCTGATGTTCCGAGGGACCTGGAAGTTGTTGCTCCGACCCCAOCCAGCCTACTGATCAG
 4210 4220 4230 4240 4250 4260 4270 4280 4290 4300 4310 4320

W D A P A V T V R Y Y R I T Y G E T G G N S P V Q E F T Y P G S K S T A T I S G
 CTGGGATGCTOCTGCTCACAGTGAGATATTACAGGATCACTTACCGAGAAACAGGAGCAAAATAGCOCTGTCCAGGAGTTCACTGTGCTCCGAGCAAGTCTACAGCTACCATCAGCCG
 4330 4340 4350 4360 4370 4380 4390 4400 4410 4420 4430 4440

25
 L K P G V D Y T I T V Y A V T G R G O S P A S S K P I S I N Y R T E I O K P S Q
 CCTTAAOCTGGAGTTGATTATACCATCACTGTGTATGCTGTCACTGGCCGTGGAGACAGOOOCCAGCAGCAAGCCAAFTTCCATTAAATTAOOGAACAGAAATTGACAAACCATOCCA
 4450 4460 4470 4480 4490 4500 4510 4520 4530 4540 4550 4560

H O V T D V O D N S I S V K W L P S S S P V T G Y R V T T T P K N G P G P T K T
 GATGCAAGTGAOCCGATGTTCAGGACAACAGCATTAGTGCAAGTGGCTGGCTTCAAGTTCCOCTGTTACTGGTTACAGAGTAOCCACCCTOCCAAAAATGGACCAAGGACCAACAAAAAC
 4570 4580 4590 4600 4610 4620 4630 4640 4650 4660 4670 4680

K T A G P D O T E M T I E G L O P T V E Y V V S V Y A Q N P S G E S O P L V O T
 TAAACTGCAGGTCCAGATCAACAGAAATGACTATTGAAGCTTGCAGCCACAGTGGAGTATGTGGTTAGTGTCTATGCTCAGAAATCCAGCCGAGAGATCAGCCTCTGGTTCCAGAC
 4690 4700 4710 4720 4730 4740 4750 4760 4770 4780 4790 4800

6/43

Figure 2F

²⁶
A V T N I D R P K G L A F T D V D V D S I K I A W E S P O G Q V S R Y R V T Y S
TCCAGTAACCAACATTGATCGCCCTAAGGACTGGCATTCACTGATGTGGATGTGGATTCCATCAAAAATGCTTGGGAAGGCCACAGGGCAAGTTTCCAGGTACAGGGTGACCTACTC
4810 4820 4830 4840 4850 4860 4870 4880 4890 4900 4910 4920

S P E D G I H E L F P A P D G E E D T A E L O G L R P G S E Y T V S V V A L W D
GAGCCCTGAGGATGGAATCCATGAGCTATTCCCTGCACCTGATGGTGAAGAAGACACTGCAGAGCTGCAAGGCTCAGAOCGGGTTCTGAGTACACAGTCAGTGTGGTTCCCTTGACCA
4930 4940 4950 4960 4970 4980 4990 5000 5010 5020 5030 5040

²⁷
D H E S Q P L I G T O S T A I P A P T D L K F T Q V T P T S L S A Q W T P P H Y
TGATATGGAGAGCCAGCCCTGATTGGAACCCAGTCCACAGCTATTCCCTGCACCACTGACCTGAAGTTCACTCAGGTCAACCCACAAGGCTGAGGGGCCAGTGCACACCCCAATGT
5050 5060 5070 5080 5090 5100 5110 5120 5130 5140 5150 5160

O L T G Y R V R V T P K E K T G P H K E I N L A P D S S S V V V S G L M V A T K
TCAGCTCACTGGATATCGAGTCCGGTGAACCCCAAGGAGAAGAOCGGACCAATGAAGAATCAACCTTGCTCTGACAGCTCATCCGTGGTTGTATCAGGACTTATGGTGGCCACCAA
5170 5180 5190 5200 5210 5220 5230 5240 5250 5260 5270 5280

²⁸
Y E V S V Y A L K D T L T S R P A Q G V V T T L E N V S P P R R A R V T D A T E
ATATGAAGTGAGTGTCTATGCTCTTAAGGACACTTTGACAAGCAGAACAGCTCAGGGTGTGTCAOCCACTCTGGAGAAIGTCAGCCCAOCCAAGAAGGCTCGTGTGACAGATGCTACTGA
5290 5300 5310 5320 5330 5340 5350 5360 5370 5380 5390 5400

T T I T I S W R T K T E T I T G F Q V D A V P A N G O T P I Q R T I K P D Y R S
GAOCCATCACCATTAGCTGGAGAACCAAGACTGAGACGATCACTGGCTTCCAAGTTGATGCGGTTCCAGCCAAATGGCCAGACTCCAATCCAGAGAACCA?CAAGCCAGATGTCAGAAG
5410 5420 5430 5440 5450 5460 5470 5480 5490 5500 5510 5520

²⁹
Y T I T G L O P G T D Y K I Y L Y T L N D N A R S S P V V I D A S T A I D A P S
CTACACCATCACAGGTTTACAACAGGCACTGACTACAAGATCTAOCCTGTACACCTTGAATGACAATGCTCGGAGCTCCOCTGTGGTCATCGACGGCTCCACTGCCATTGATGCCACCAIC
5530 5540 5550 5560 5570 5580 5590 5600 5610 5620 5630 5640

N L R F L A T T P N S L L V S W O P P R A R I T G Y I I K Y E K P G S P P R E V
CAOCCCTGGGTTTCCCTGGCCACCACACCCAATTCCTTGGCTGGTATCATGGCAGOCGGCCAGTGCCACGATTACCCCTACATCATCAAGTATGAGAAGCCGGGTCTCCCTCCAGAGAAGT
5650 5660 5670 5680 5690 5700 5710 5720 5730 5740 5750 5760

SUBSTITUTE SHEET

7/43

Figure 2G

V P R P R P G V T E A T I T G L E P G T E Y T I Y V I A L K N N O K S E P L I G
GGTCCCTCGGCCCCGGCCTGGTGTACAGAGGCTACTATTACTGGCCTGGAAACC GGGAAACGGAATATACAATTTATGTCATTC CCTGAAGAATAATCAGAAGAGCGAGCCCTGATTGG
5770 5780 5790 5800 5810 5820 5830 5840 5850 5860 5870 5880

³⁰
R K K T D E L P O L Y T L P H P N L H G P E I L D V P S T V O K T P F V T H P G
AAGGAAAAGACAGACGAGCTTCCCAACTGGTAACCCCTCCACAACCCCAATCTTCATGGAACAGAGATCTTGGATGTTCCTTCACAGTTCAAAAGACCCCTTTCGTCAACCCACCCCTGG
5890 5900 5910 5920 5930 5940 5950 5960 5970 5980 5990 6000

Y D T G N G I O L P G T S G Q O P S V G Q O M I F E E H G F R R Y T P P T T A T
GTATGACACTGGAAATGGTATTGAGCTTCCCTGGCACTTCTGGTCAGCAACCCAGTGTGGGCAACAATGATCTTTGAGGAACATGGTTT TAGCCCGAACCAACCCGCCCACAACCCGCCAC
6010 6020 6030 6040 6050 6060 6070 6080 6090 6100 6110 6120

³¹
P I R H R P R P Y P P N V G Q E A L S O T T I S W A P F O D T S E Y I I S C H P
CCCCATAAGGCATAGGCCAAGACCATAACCCGCGAATGTAGGACAAGAAGCTCTCTCTCAGACAACCATCTCATGGGCCCCATTCCAGGACACTTCTGAGTACATCATTTTCATGTCATCC
6130 6140 6150 6160 6170 6180 6190 6200 6210 6220 6230 6240

Y G T D E E P L Q F R Y P G T S T S A T L T G L T R G A T Y N I I V E A L K D Q
TGTGGCACTGATGAAGAACCCCTTACAGTTCAGGGTTCCTGGAACCTCTAACCAGTCCACTCTGACAGGCCCTACCAGAGGTCCACCTACAACATCATAGTGGAGCCACTGAAGACCA
6250 6260 6270 6280 6290 6300 6310 6320 6330 6340 6350 6360

³² Q R H K Y R E E V V T V G N S V N E G L N O P T D D S C F D P Y T V S H Y A V G
GCAGAGGCATAAGGTTGGGAAGAGGTTGTACCGTGGGCAACTCTGTCAACGAAGGCTTGAACCAACCTACGGATGACTCTGTCTTTGACCCCTACACAGTTTCCCATTTATGCCGTTGG
6370 6380 6390 6400 6410 6420 6430 6440 6450 6460 6470 6480

³³ D E W E R M S E S G F K L L C O L L G F G S G H F R C D S S R W C H D N G V M Y
AGATGAGTGGGAACGAATGTCTGAATCAGGCTTAAACTGTGTGCCAGTGCTTAGGCTTTGGAAGTGGTCAFTTCAGATGTGAFTCATCTAGATGGTCCCATGACAAATGGTGTGAAC TA
6490 6500 6510 6520 6530 6540 6550 6560 6570 6580 6590 6600

³⁴ K I G E K W D R O G E N G Q M H S C T C L G N G K G E F K C D P H E A T C Y D D
CAAGATTGAGAGAAGTGGGACCGTCAAGGAGAAAATGCCAGATGATGAGCTGCACATGCTCTGGGAACCGAAAAGSAGAATCAAGTGTGACCCCTCATGAAGCAACGTTGTACGATGA
6610 6620 6630 6640 6650 6660 6670 6680 6690 6700 6710 6720

³⁵

8/43

SUBSTITUTE SHEET

Figure 2H

G K T Y H V G E O W Q K E Y L G A I C S C T C F G G O R G W R C D N C R R P G G ³⁶
 TGGGAAGACATACCAAGTAGGAGAACAGTGGCAGAAAGGAATATCTGGGTGCLATTTGCTCCTGCACATGCTTTGGAGGCCAGGGGGCTGGGGCTGTGACAACCTGGCCAGACCTGGGG
 6730 6740 6750 6760 6770 6780 6790 6800 6810 6820 6830 6840

E P S P E G T T G Q S Y N Q Y S Q R Y H Q R T N T N V N C P I E C F M P L D V O
 TGAACCCAGTCCCGAAGCCACTACTGCCAGTCCTACAACCAGTATTCTCAGAGATACCATCAGAGAACAACTAATGTAAATTCOCCAATGAGTGCTTCATGCCCTTAGATGTACA
 6850 6860 6870 6880 6890 6900 6910 6920 6930 6940 6950 6960

A D R E D S R E
 GGCTGACAGAGAAGATTCCCGAGAGTAAATCATCTTTCCAATCCAGAGGAACAAGCATGTCTCTCTGCCAAGATCCATCTAACTGGAGTGATGTAGCAGACCCAGCTTAGAGTTCTTC
 6970 6980 6990 7000 7010 7020 7030 7040 7050 7060 7070 7080

TTTCTTTCTTAAGCCCTTTGCTCTGGAGGAAGTCTCCAGCTTCAGCTCAACTCACAGCTTCTCCAAGCATCAOCCCTGGGAGTTTCTCTAGGGGTTTCTCATAAATGAGGGCTGCACATT
 7090 7100 7110 7120 7130 7140 7150 7160 7170 7180 7190 7200

GCCTGTTCTGCTTCGAAGTATTCAAATCCGCTCAGTATTTTAAATGAAGTGATTTCTAAGATTTGGTTTGGGATCAATAGGAAAGCATATGCAGCCAAACCAAGATGCAAATGTTTTGAAAT
 7210 7220 7230 7240 7250 7260 7270 7280 7290 7300 7310 7320

GATATGACCAAAATTTTAAAGTAGGAAAGTCAOCCAAACACTCTGCTTTCACTTAAGTGTCTGGCCCGCAATACTGTAGGAACAAGCATGATCTTGTACTGTGATAATTTAAATATCCA
 7330 7340 7350 7360 7370 7380 7390 7400 7410 7420 7430 7440

CAGTACTCACTTTTTCCAAATGATCCTAGTAATTCOCTAGAAATATCTTTCTCTTAOCTGTTATTTATCAATTTTTCCAGTATTTTTATACGGAAAAAATGTATTGAAAACACTTAGT
 7450 7460 7470 7480 7490 7500 7510 7520 7530 7540 7550 7560

ATGCAGTTGATAAGAGGAATTTGGTATAATTATGGTGGGTGATTAATTTTTATACTGTATGTGCCAAGCTTTACTACTGTGGAAAGACAACCTGTTTTAAATAAAGATTACATTCACACA
 7570 7580 7590 7600 7610 7620 7630 7640 7650 7660 7670 7680

AAAAAAAAAAAAAAAAAAAAA
 7690 7700 5 15 25 35 45 55 65 75 85 95

SUBSTITUTE SHEET

Figure 3A

Pair 1

1 5'- AATTCATATGCAGGCACAGCAAATGGTTCAGCCCCAGTCCCCGGTGGCTGTCAGTCAAAGCAAGCCCCGGT - 3'
 # 2 3'- GTATACGTCCGTGTCGTTTACCAAGTCGGGGTCAGGGGCCACCGACAGTCAGTTTCGTTCCGGGCCAACAAATA - 5'

Pair 2

3 5'- GTTATGACAATGGAAAACACTATCAGATAAATCAACAGTGGGAGCGGACCTACCTAGGTAATGTGTTG - 3'
 # 4 3'- CTGTTACCTTTTGTGATAGTCTATTTAGTTGTCACCCCTCGCCTGGATGGATCCATT - 5'

Pair 3

5 5'- GTTTGTACTTGTATGGAGGAAGCCGAGGTTTAACTGCGAAAAGTAAACCTGAAGCT - 3'
 # 6 ACACAACCAACATGAACAATACCTCCTTCGGTCCAAAATTGACGCTTTCATTTGGACTTCGACTTCTCT - 5'

Pair 4

7 5'- GAAGAGACTTGCTTTGACAAGTACACTGGGAACACTTACCGAGTGGGTGACACTTATGAGCGTCTAAA - 3'
 # 8 3'- GAACGAAACTGTTTCATGTGACCCCTGTGAATGGCTCACCCACTGTGAATACTCGCAG - 5'

Figure 3B

Pair 5

9 5'- GACTCCATGATCTGGGACTGTACCTGCATCGGGGCTGGGCGAGGGAGAATAAGCTGTACC - 3'
 #10 GATTCTGAGGTACTAGACCCTGACATGGACGTAGCCCCGACCCGCTCCCTCTTATT - 5'

Pair 6

#11 5'- ATCGCCAACGCTGCCATGAAGGGGTCAGTCCTACCAGATTGGTGACACCTGGAGGAGACCACATGAGACT - 3'
 #12 GACATGGTAGCGTTTGCACGGTACTTCCCCCAGTCAGGATGGTCTAACCCTGTGGACCTCCTCTGGTGTACTCTGACCACCAA - 5'

Pair 7

#13 5'- GGTGGTTACATGTTAGAGTGTGTGTGTCTTGGTAATGGAAAAGGAGAATGGACCTGCAAGCCCATAGCTGAG - 3'
 #14 3'- TGTACAATCTCACACACACAGAACCATTACCTTTTCCTCTTACCTGGACGTTCCGGGTATCGACTCCTAG - 5'

11/43

12/43

Figure 4

Synthesis of F.N. Gene (14 - 472 b.p.)

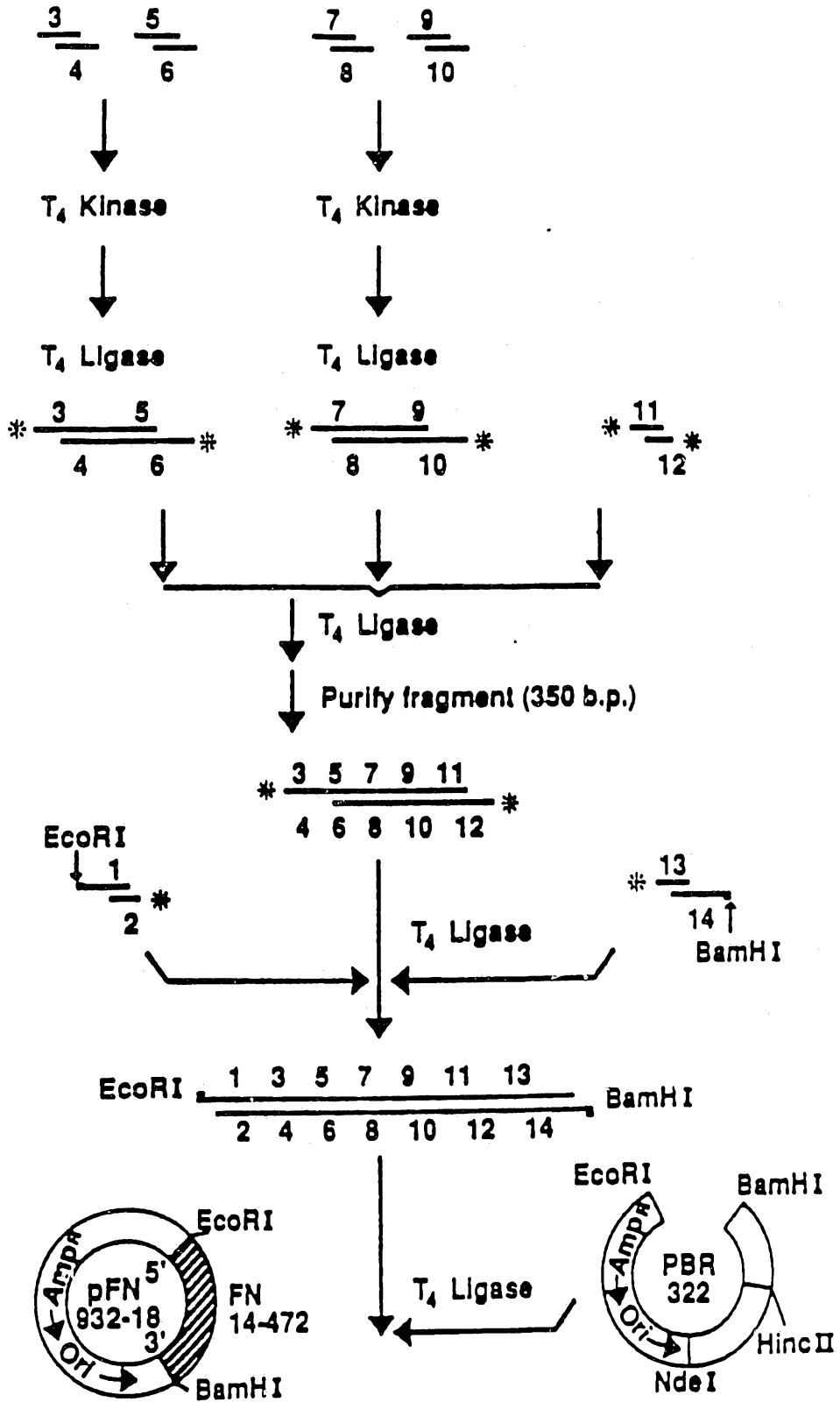
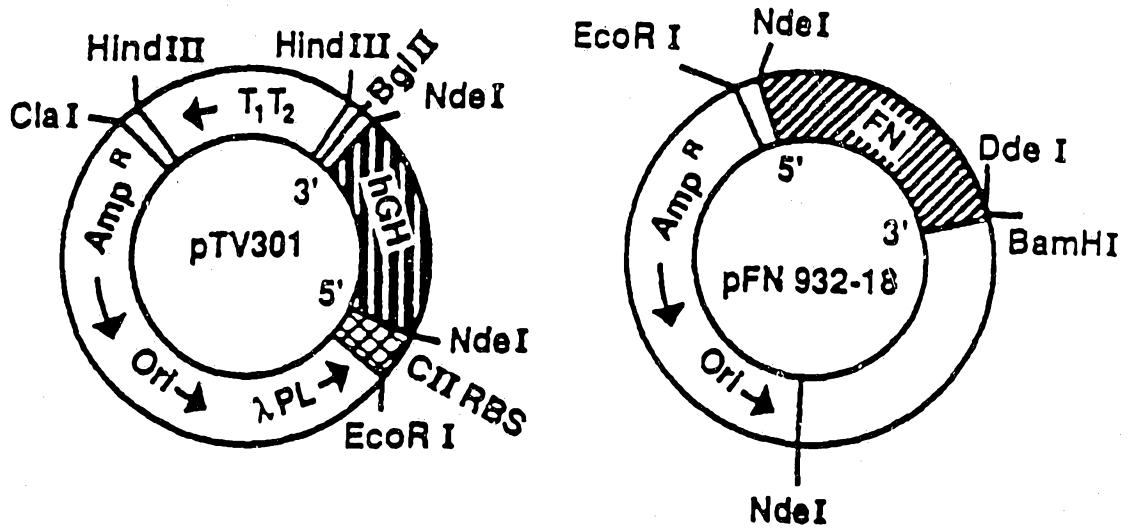

Figure 5



- | | |
|----------------------------------------------------------------------------------------------------------------------------------|-----------------------------------------------------------------------------------------------------------------------|
| <ol style="list-style-type: none">1. Nde I2. Bgl II3. Isolate Large NdeI - BglII Vector fragment | <ol style="list-style-type: none">1. Nde I2. BamHI3. Isolate NdeI - BamHI FN fragment |
|----------------------------------------------------------------------------------------------------------------------------------|-----------------------------------------------------------------------------------------------------------------------|

T₄ DNA Ligase

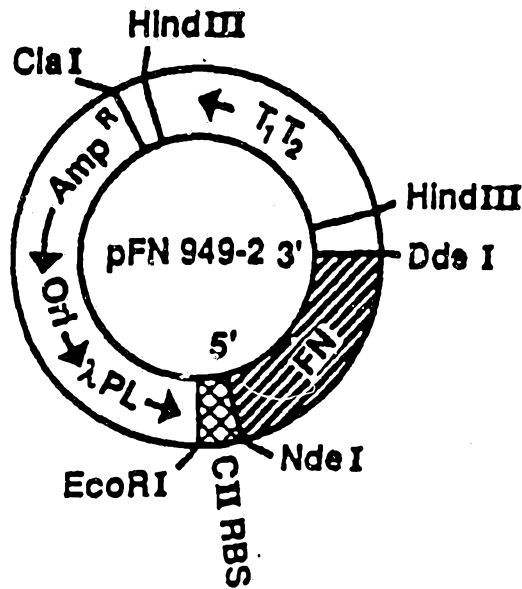

Figure 6

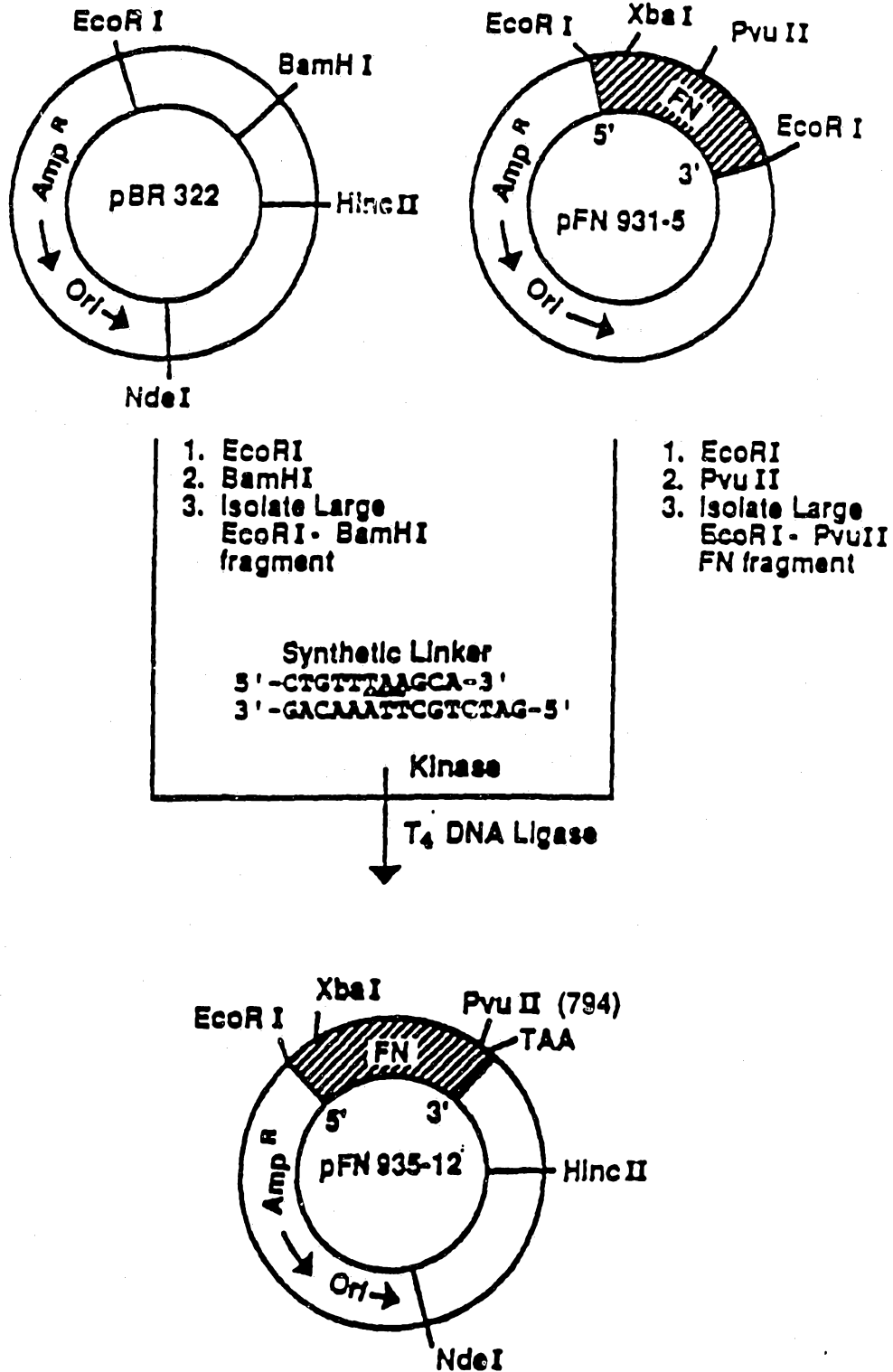

Figure 7

Pharmacokinetic Behavior of Fibronectin and Recombinant 31kD FBD in the Rat

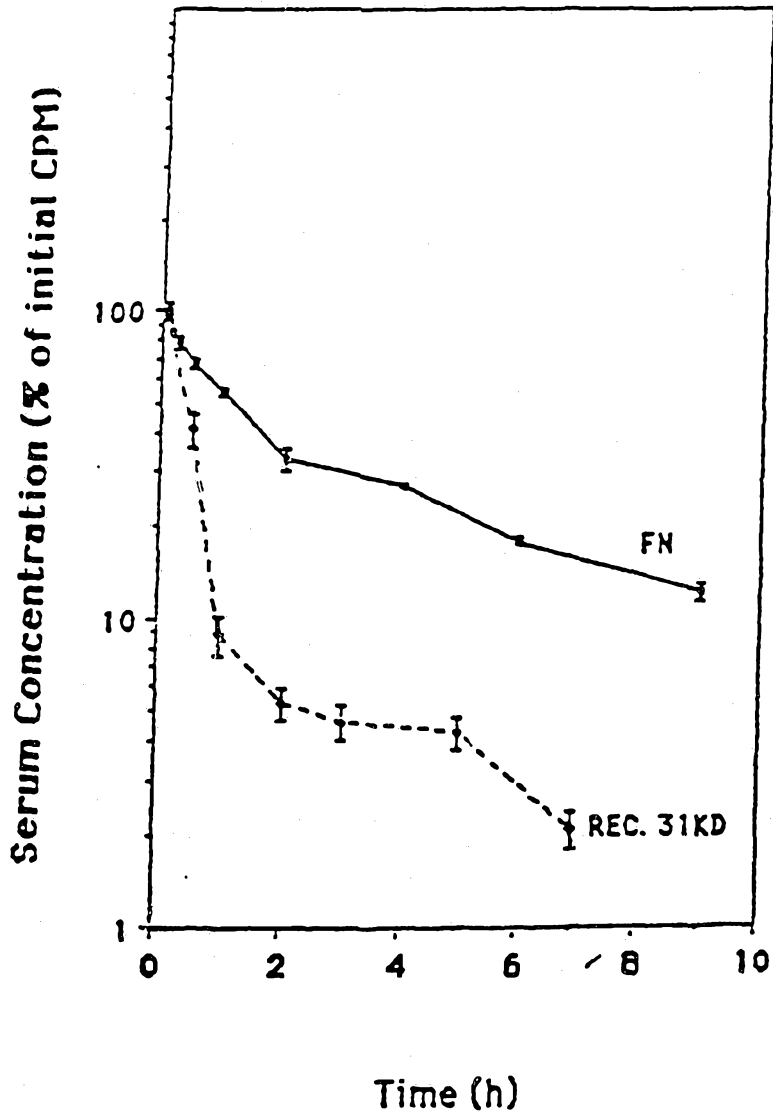
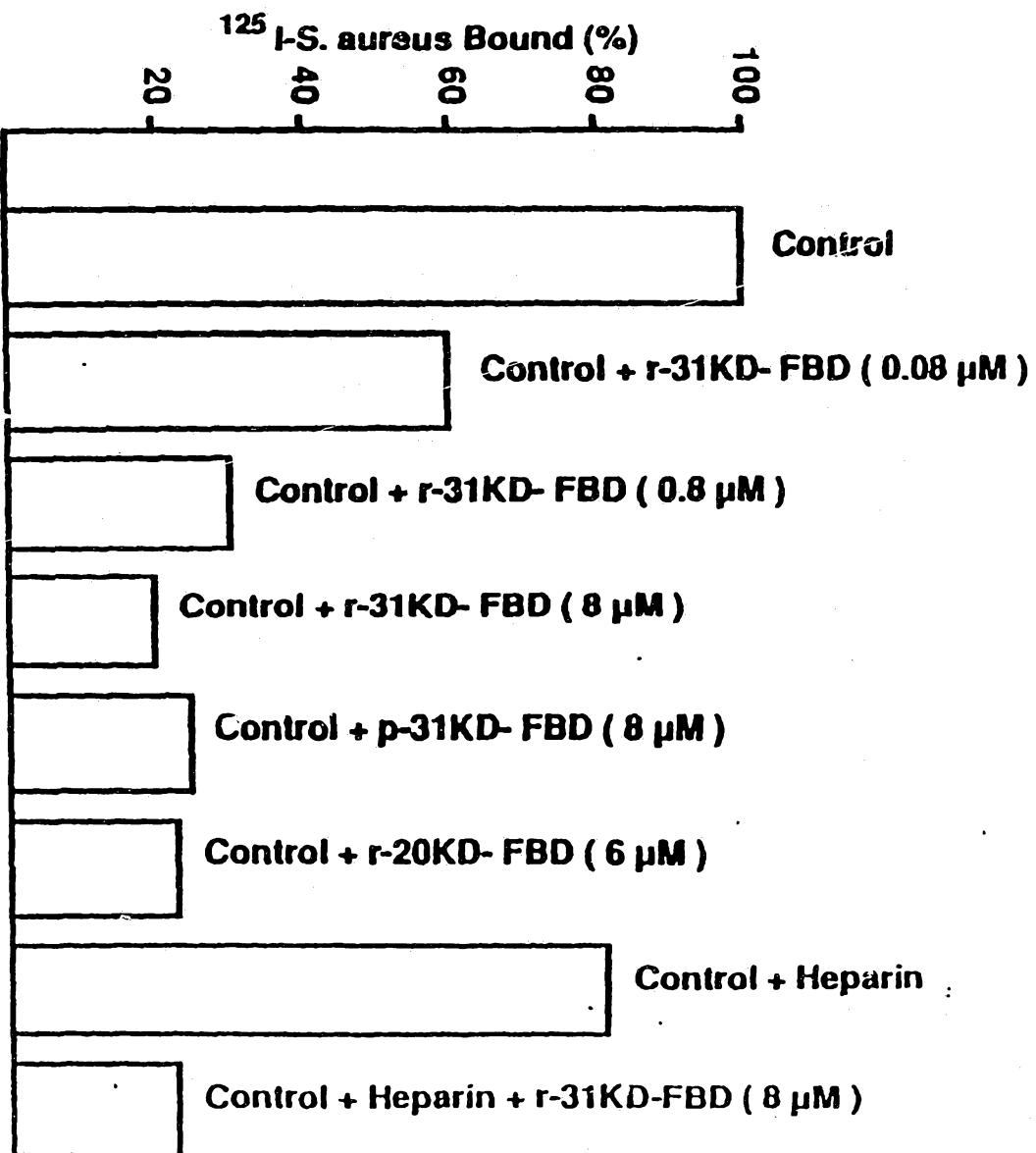

Figure 8

**Binding of *S. aureus* to Bronchial Catheters;
Effect of FBD and Heparin.**



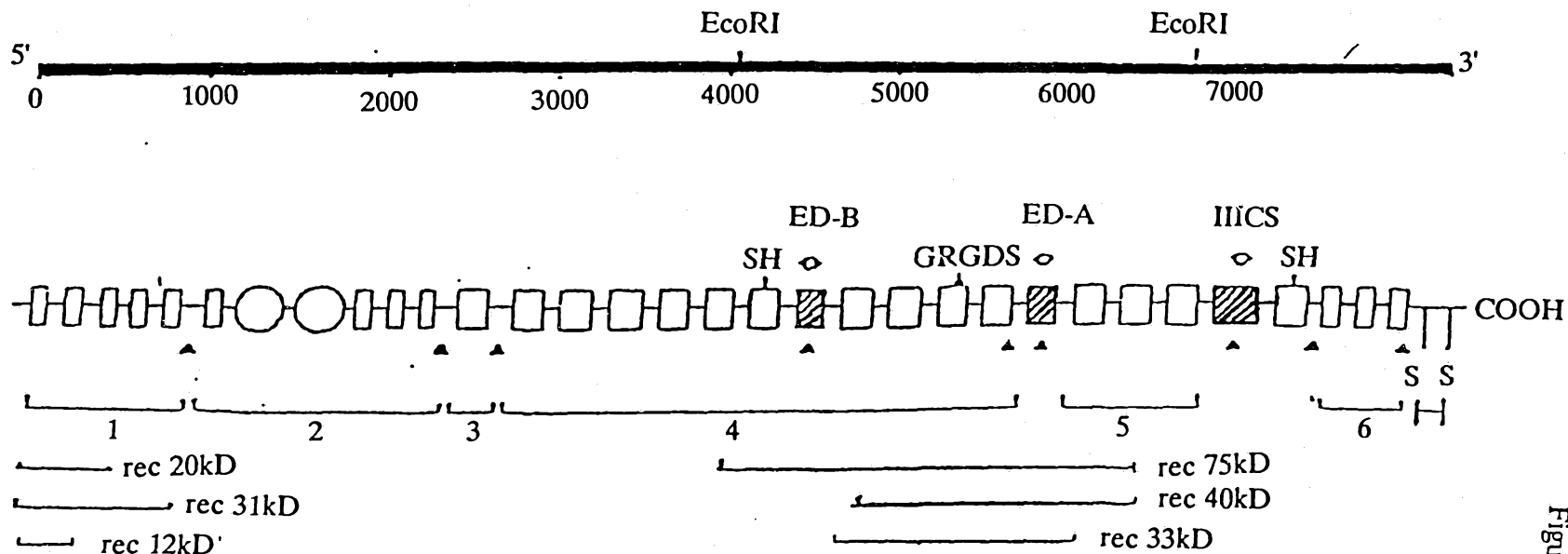

Figure 9

17/43

SUBSTITUTE SHEET

HEPARIN
S. AUREUS
FIBRIN

COLLAGEN

[HEPARIN
DNA]

CELL
HEPARIN
DNA

HEPARIN [CELL] FIBRIN

Nucleotides

FBD	rec-12 kD:	14-340
	rec-20 kD:	14-472
	rec-31 kD:	14-799
CBD	rec-40 kD:	4151-5566
	rec-75 kD:	3317-5566
	rec-33 kD:	3998-5179

18/43

Figure 10

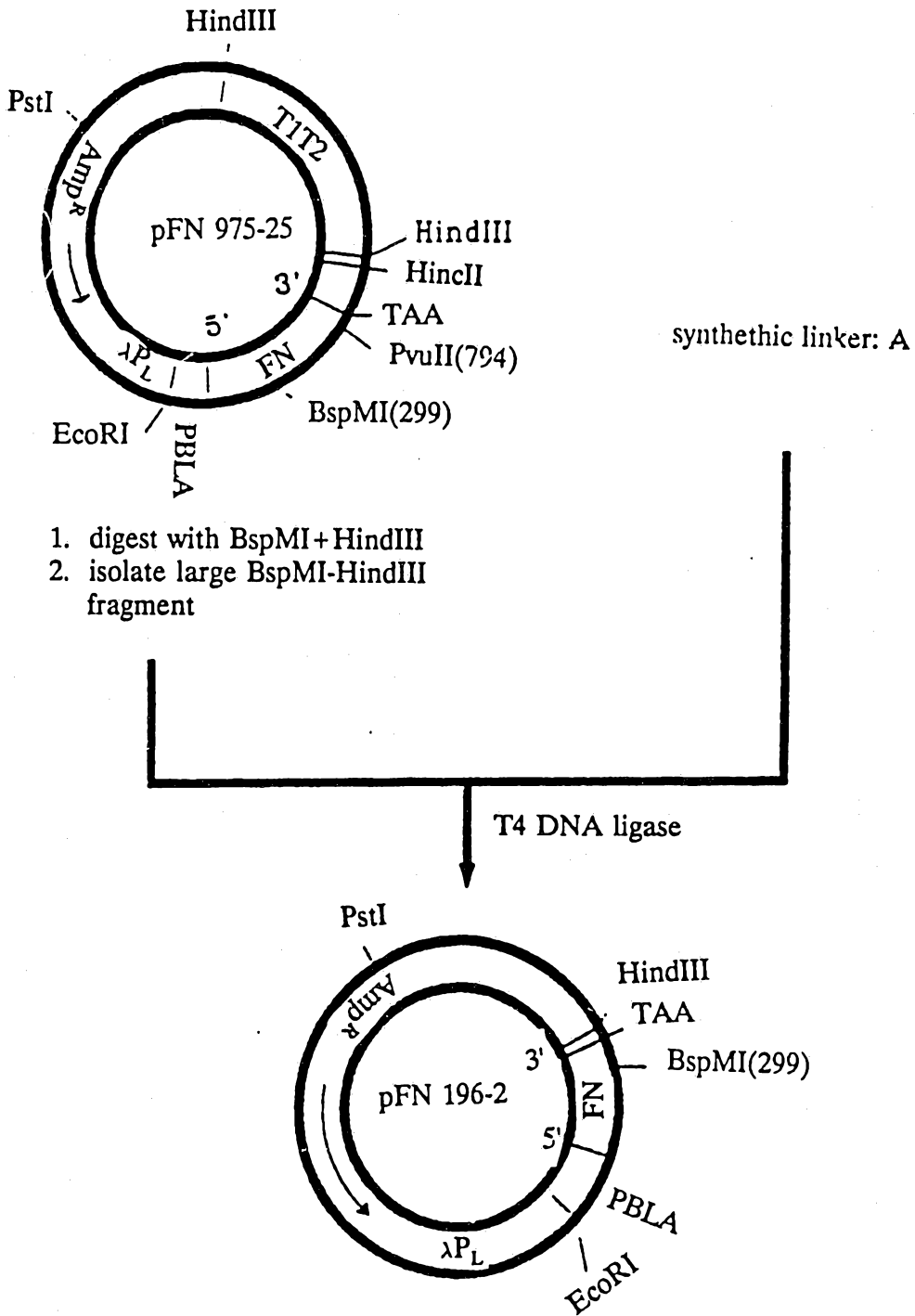

19/43

Figure 11

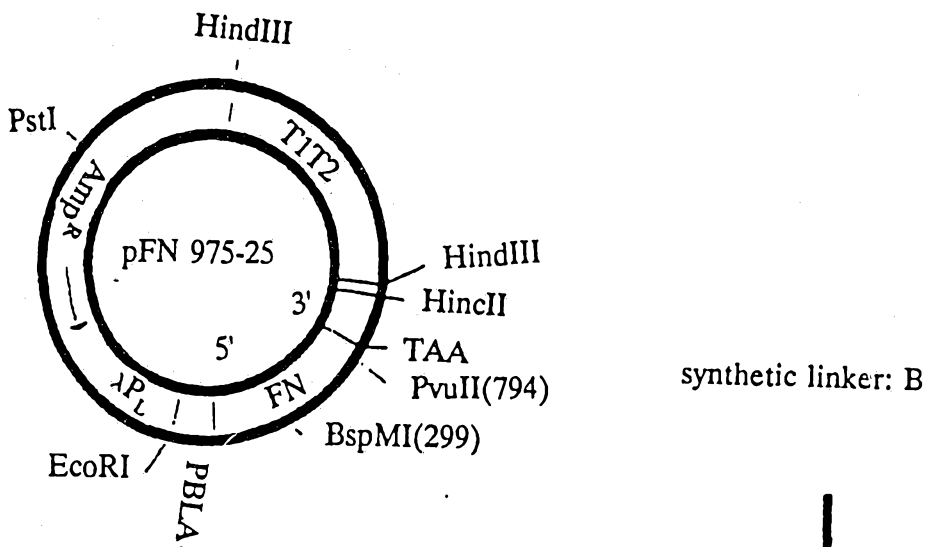

1. digest with BspMI + HindIII
2. isolate large BspMI-HindIII fragment

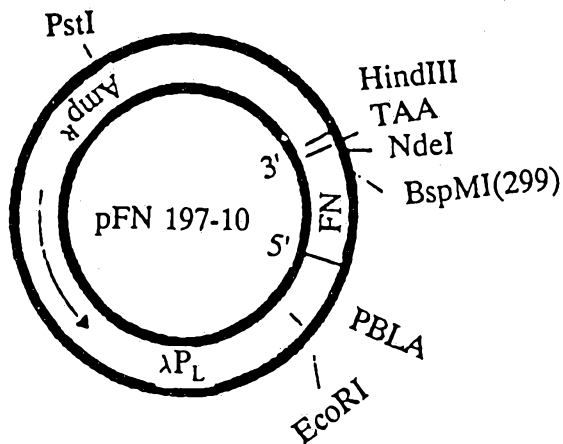
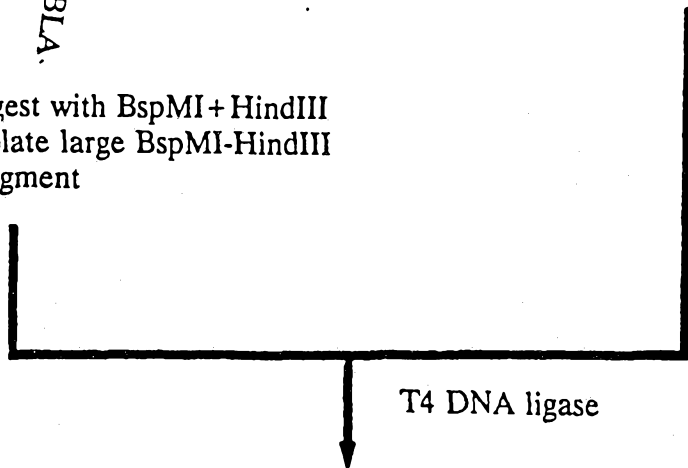

20/43

Figure 12

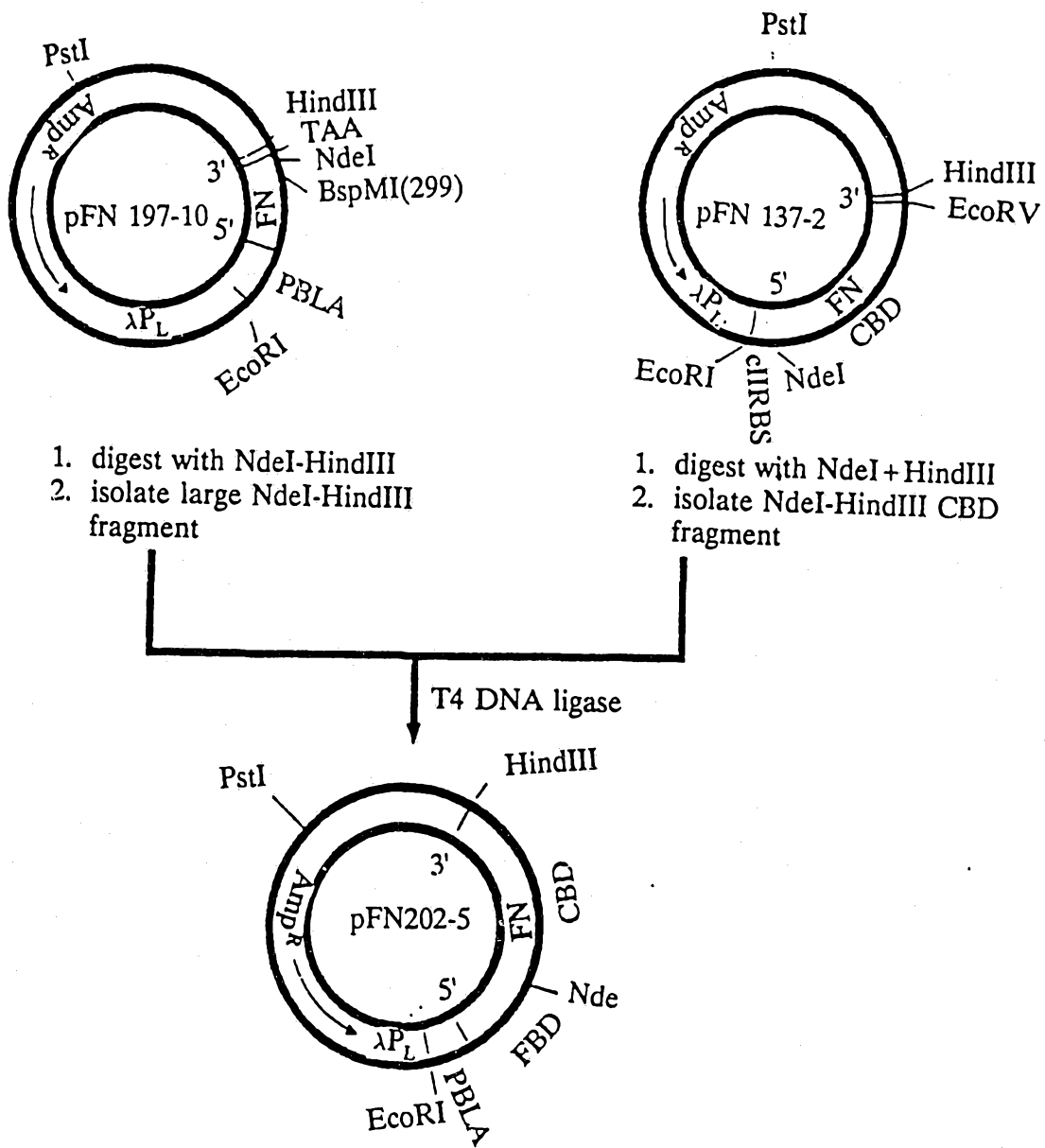

Figure 13

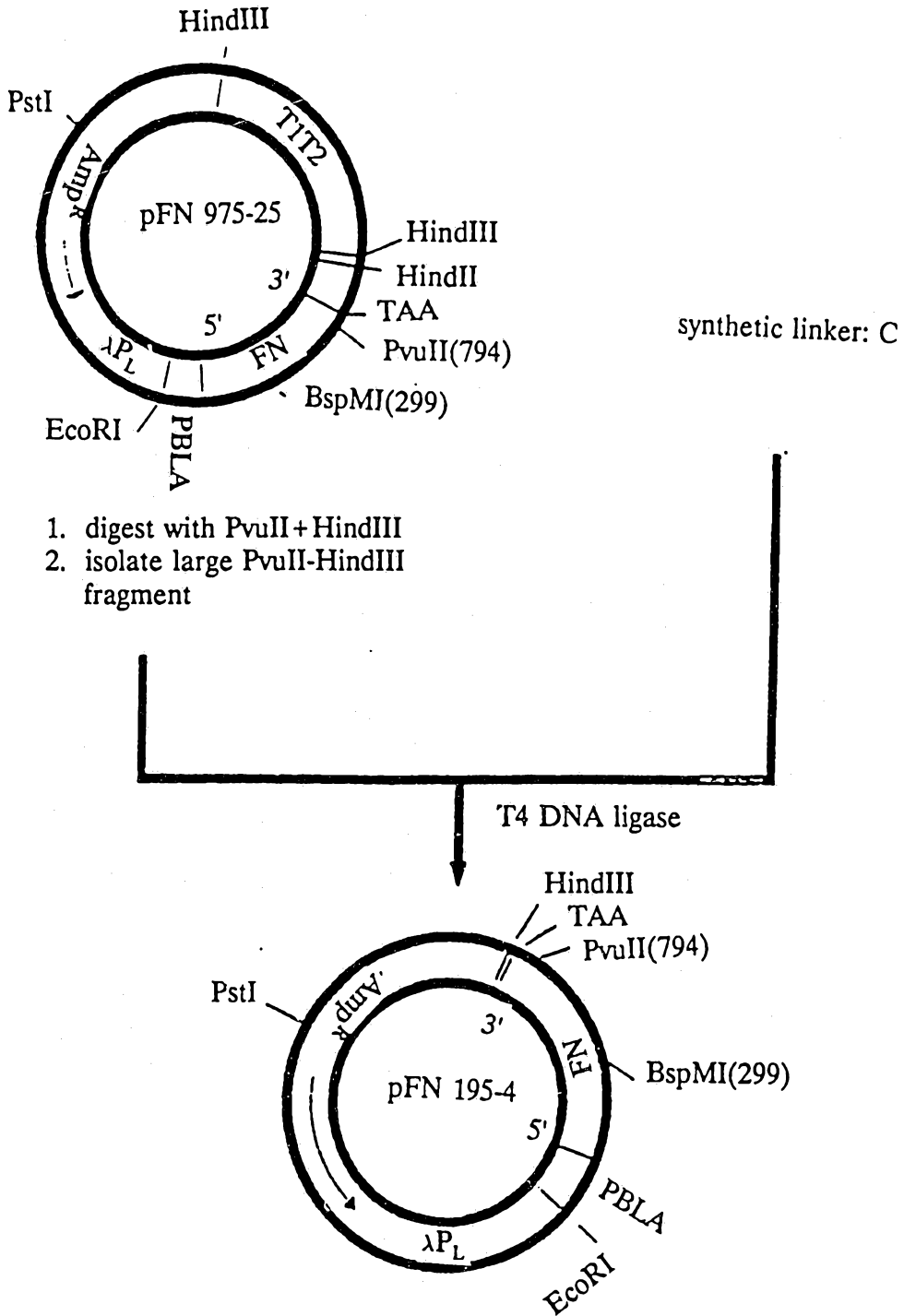
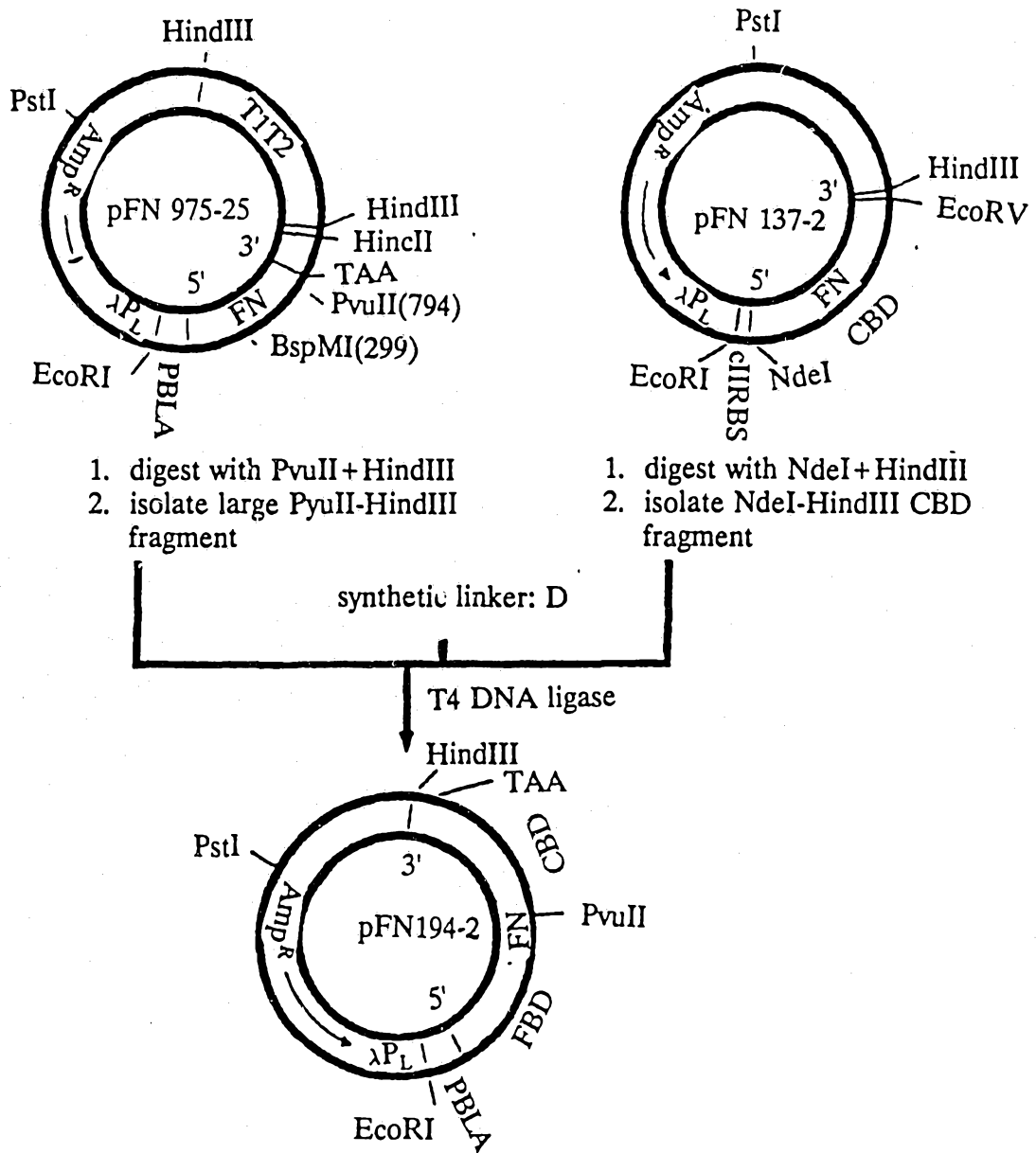

Figure 14



23/43

Figure 15

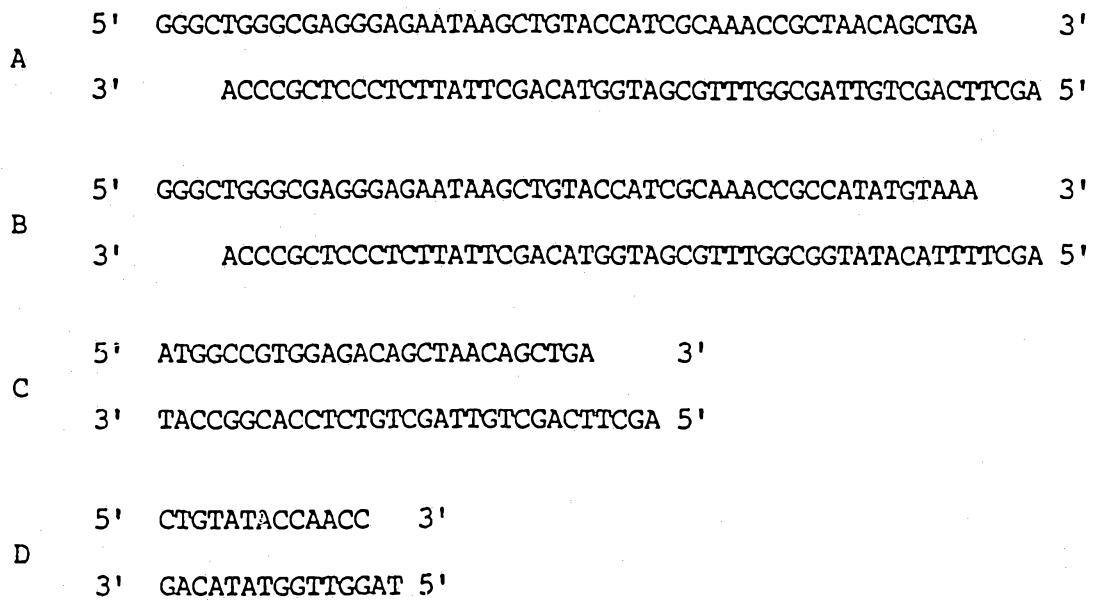
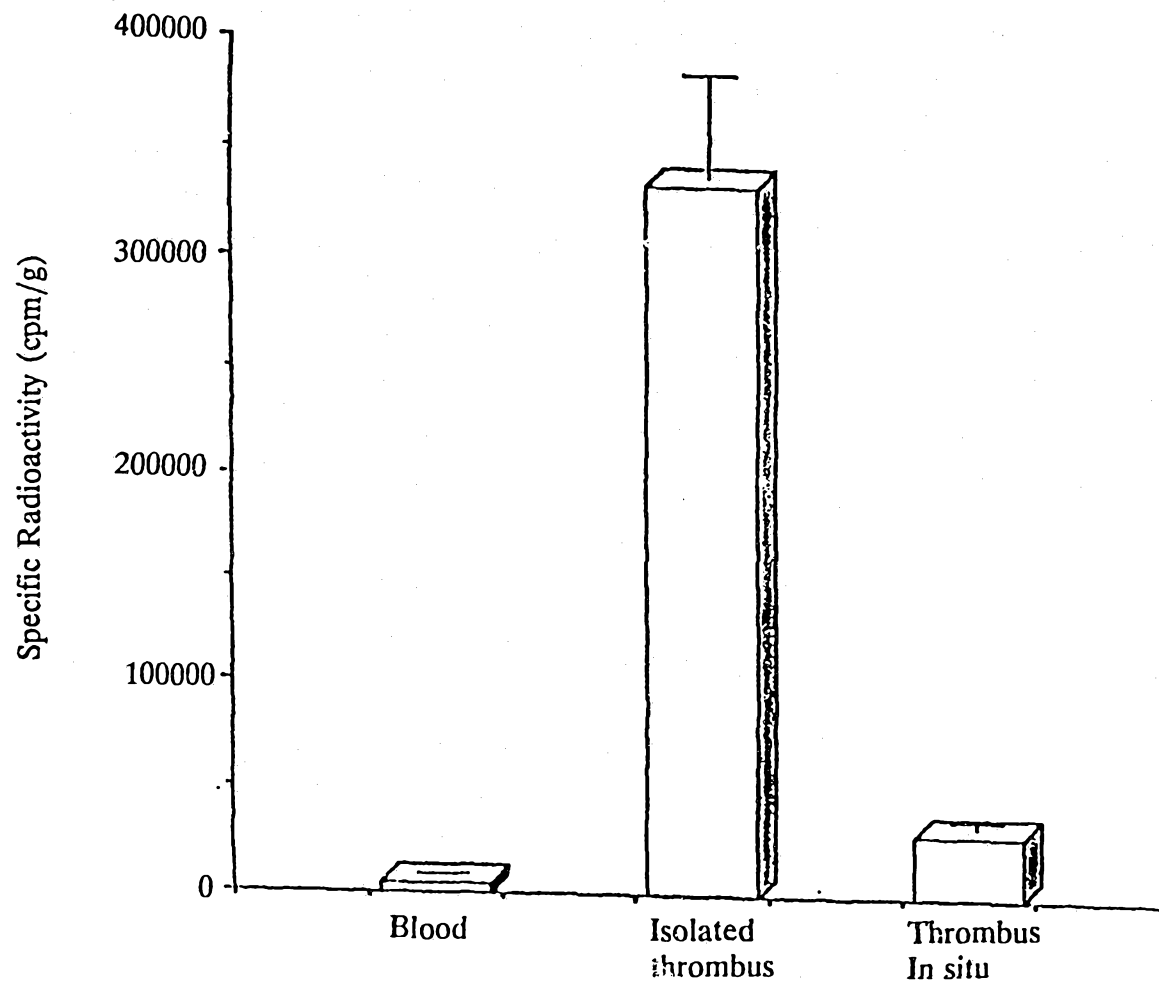

Figure 16

Uptake of Labeled 31KD rFBD by Blood Clots in the Rat Coil Model



24/43

Figure 17

COMPARISON BETWEEN 12, 20 & 31KD FBD MOLECULES

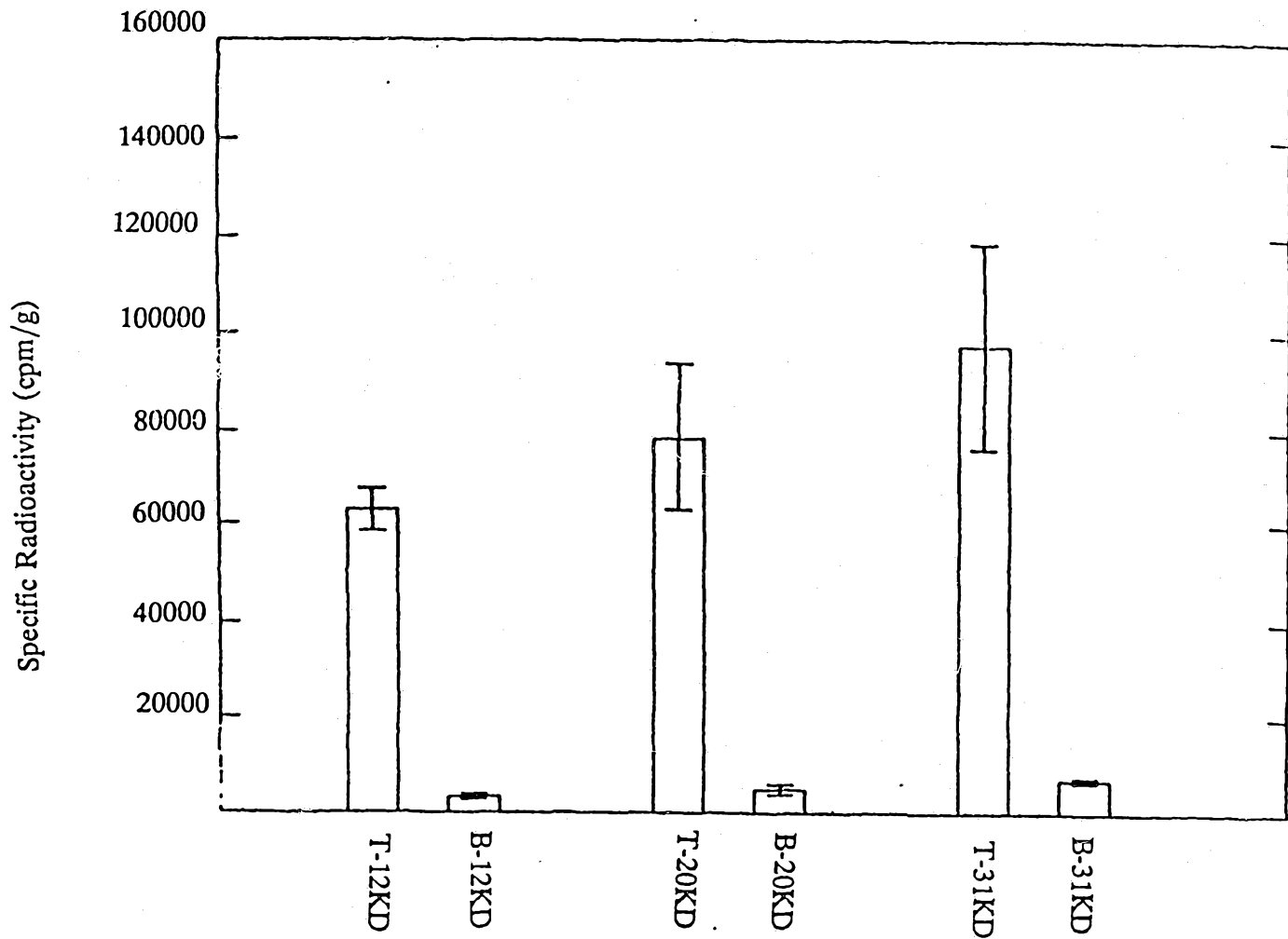
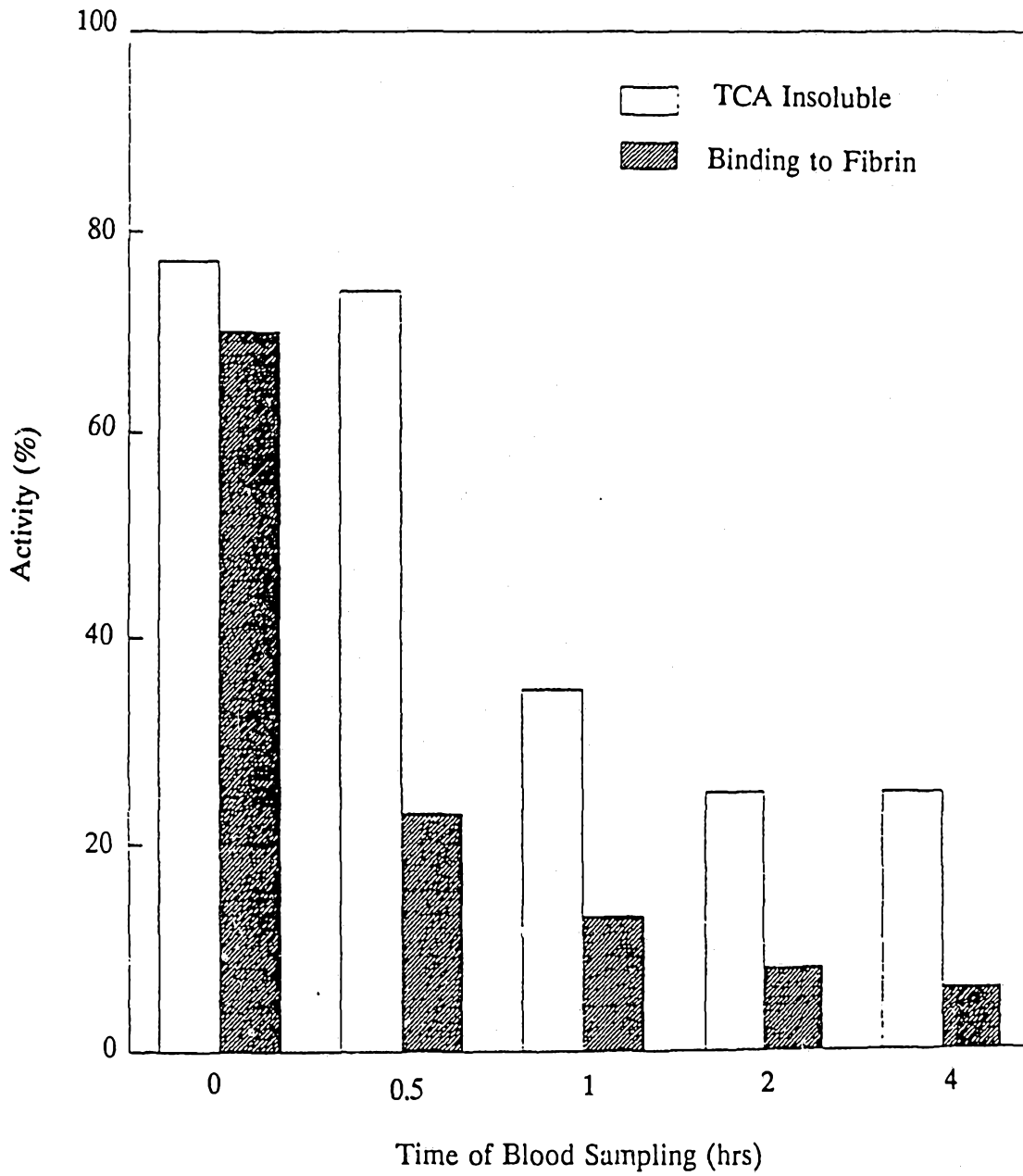

Figure 18

Metabolic Stability of rFBD in Rats;
Ex-vivo Binding to Fibrin vs. TCA Insolubility



27/43

Figure 19

Binding of FBD to Fibrin clot (reaction II)
comparison between various recombinant
and plasmatic FBD molecules

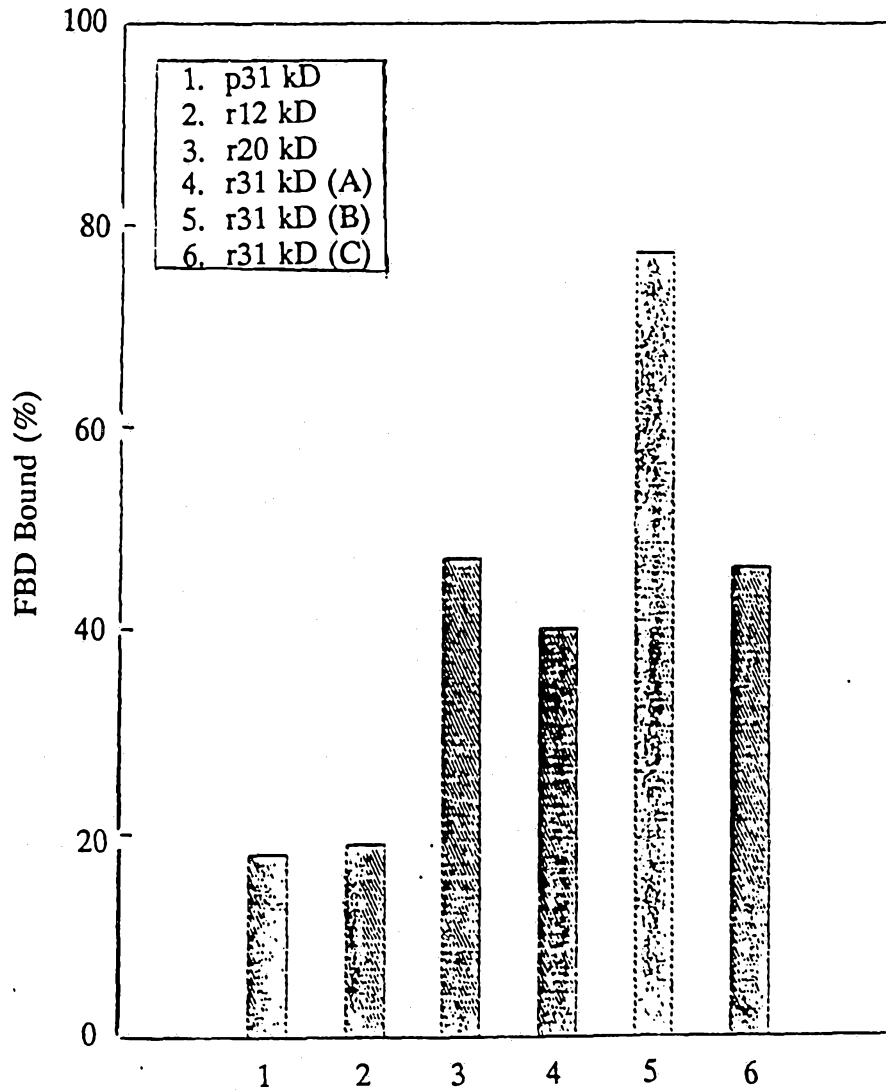

Binding of FBD to Fibrin clot (reaction II);
Comparison between fresh and frozen Fibrin clots

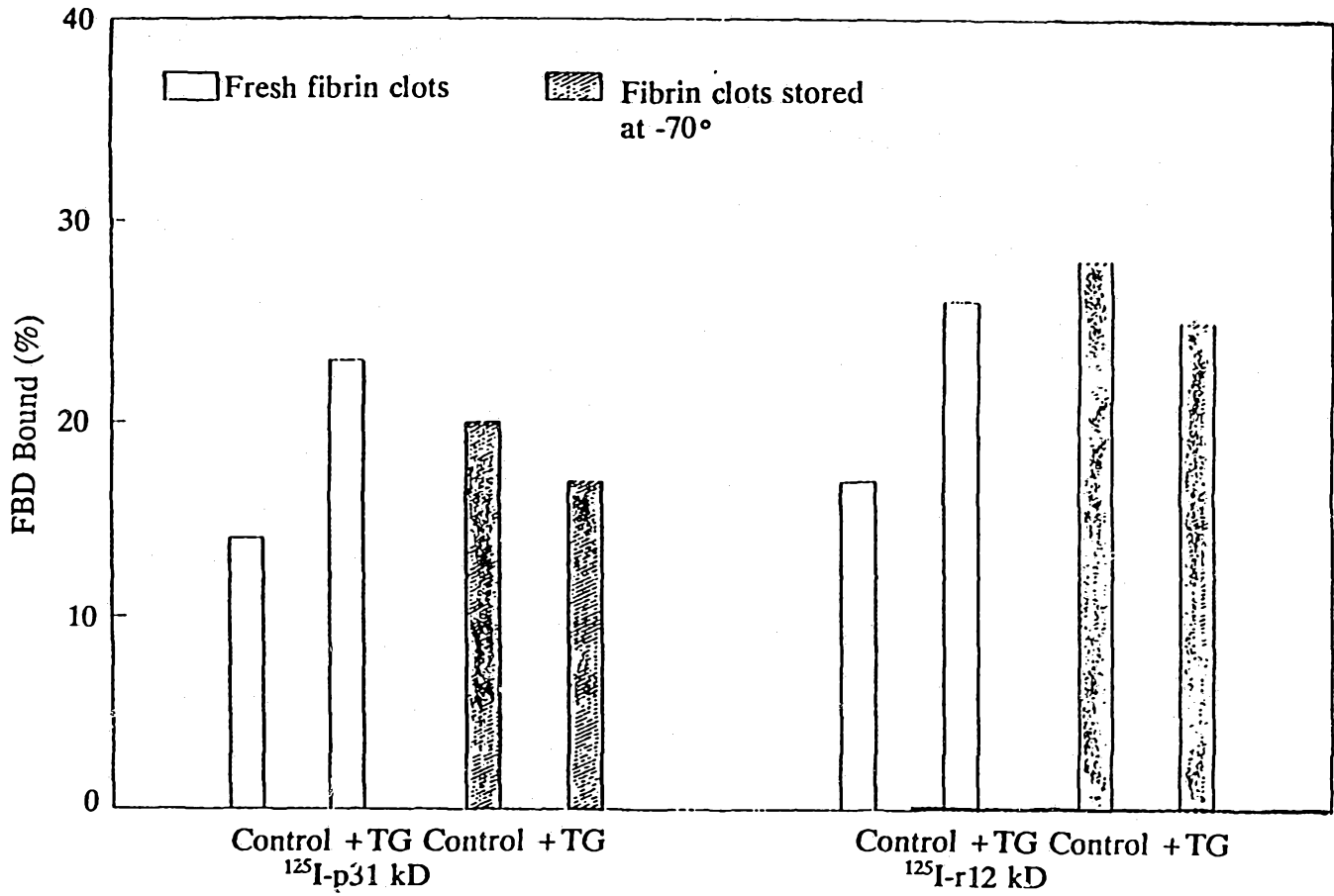
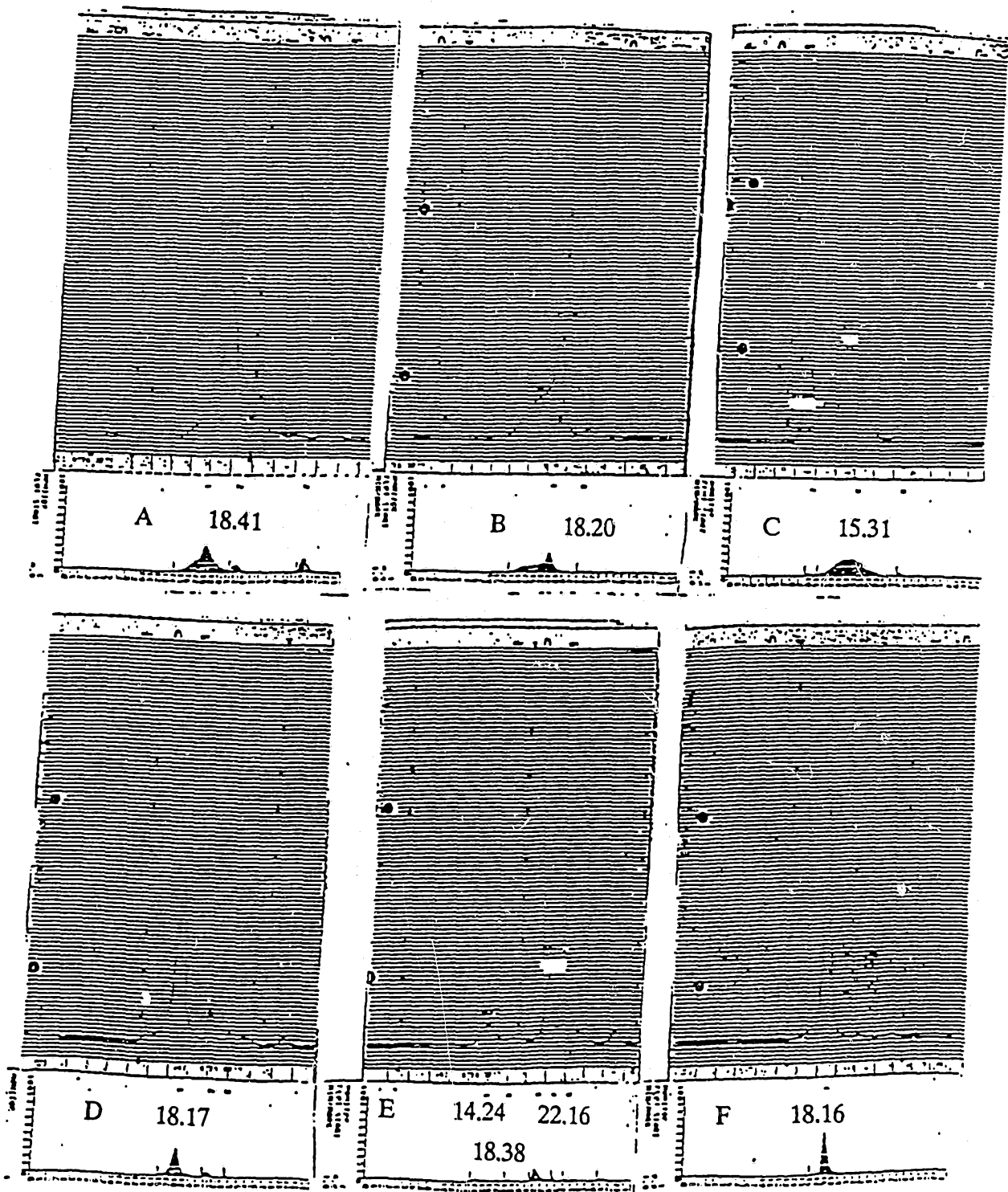

Figure 20

28/43

SUBSTITUTE SHEET

Figure 21



30/43

Figure 22

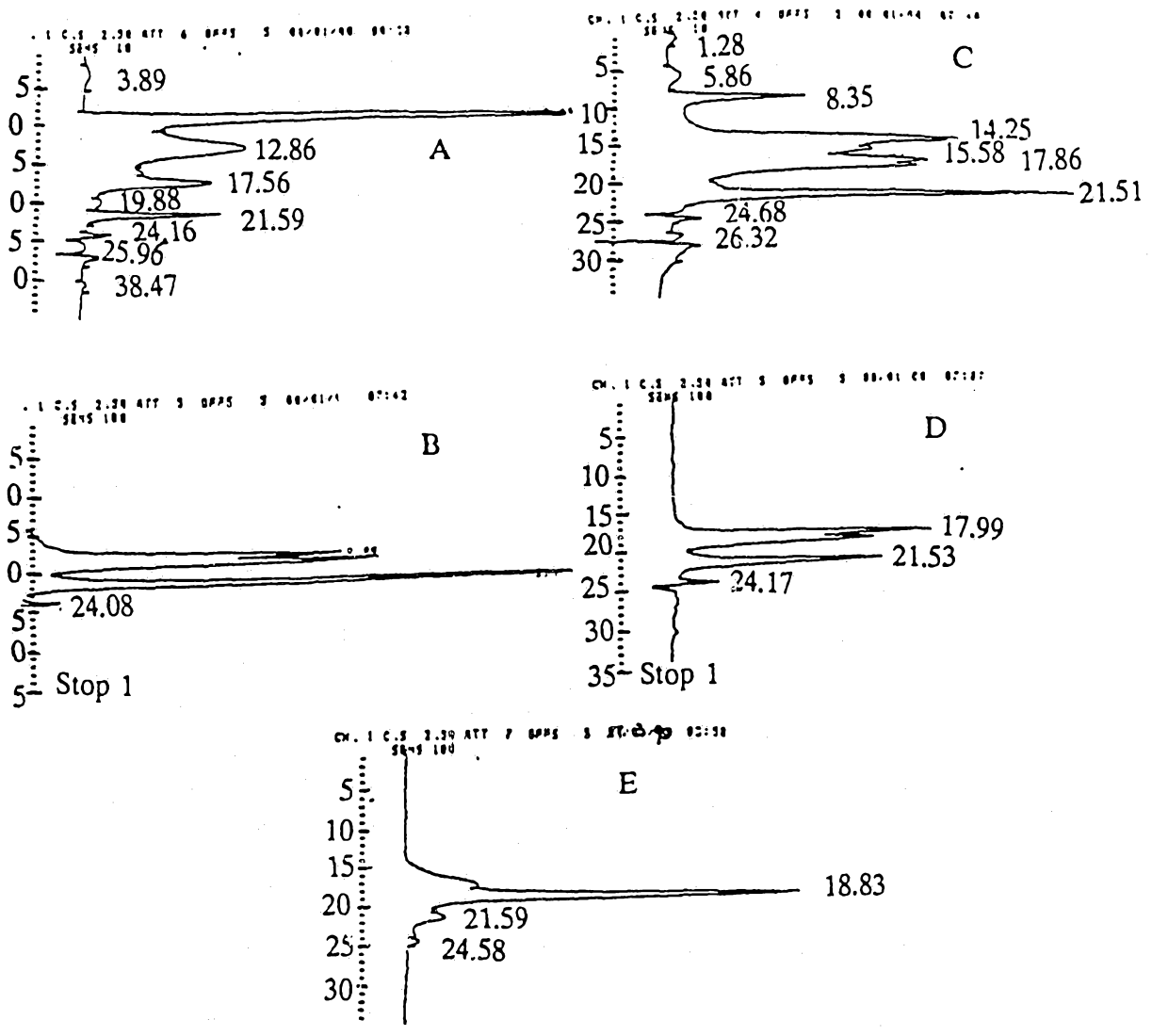
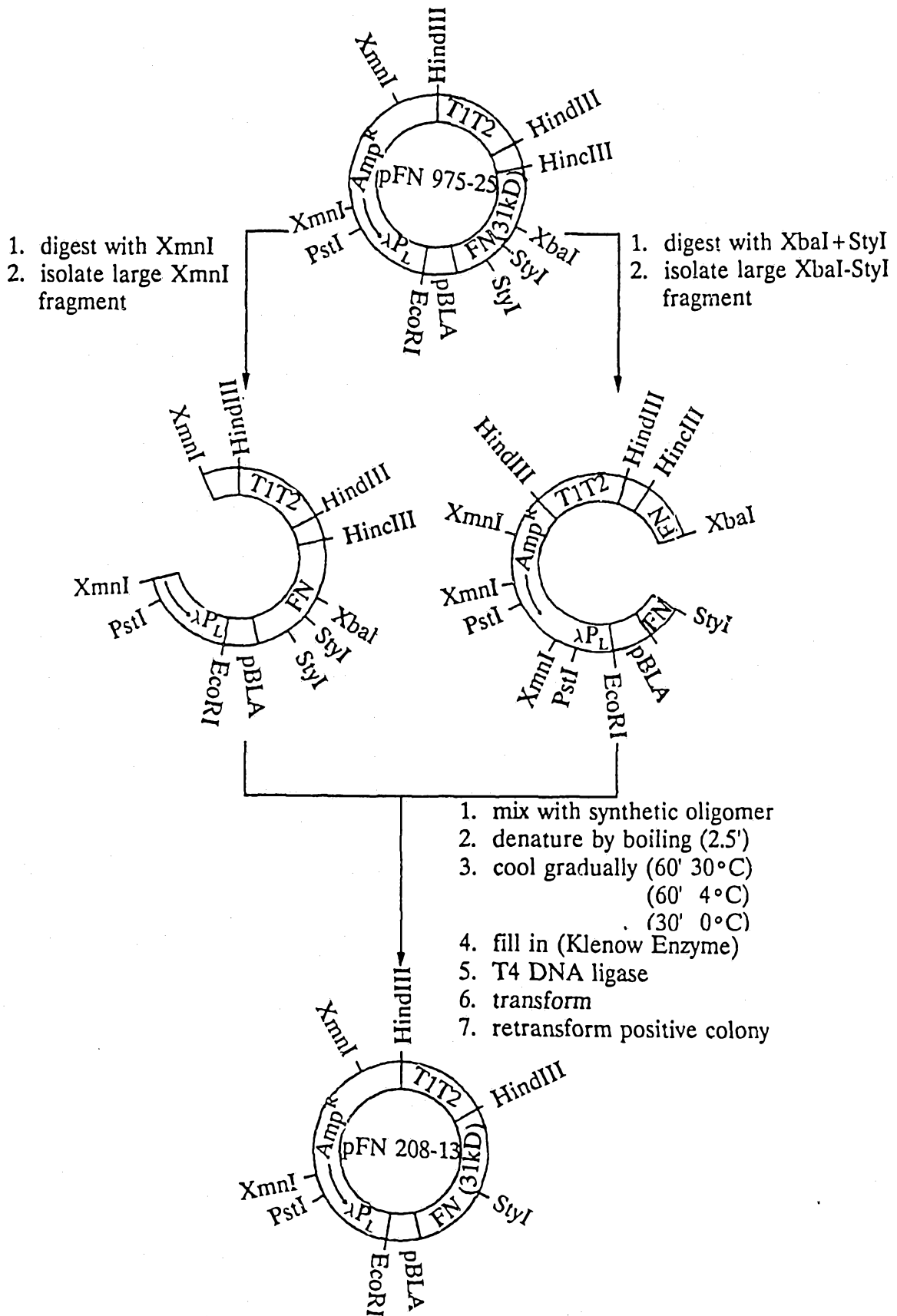

Figure 23



32/43

Figure 24

5' GCCCATAGCTGAAAAGTAATTTGATCATGCTGC 3'

Figure 25

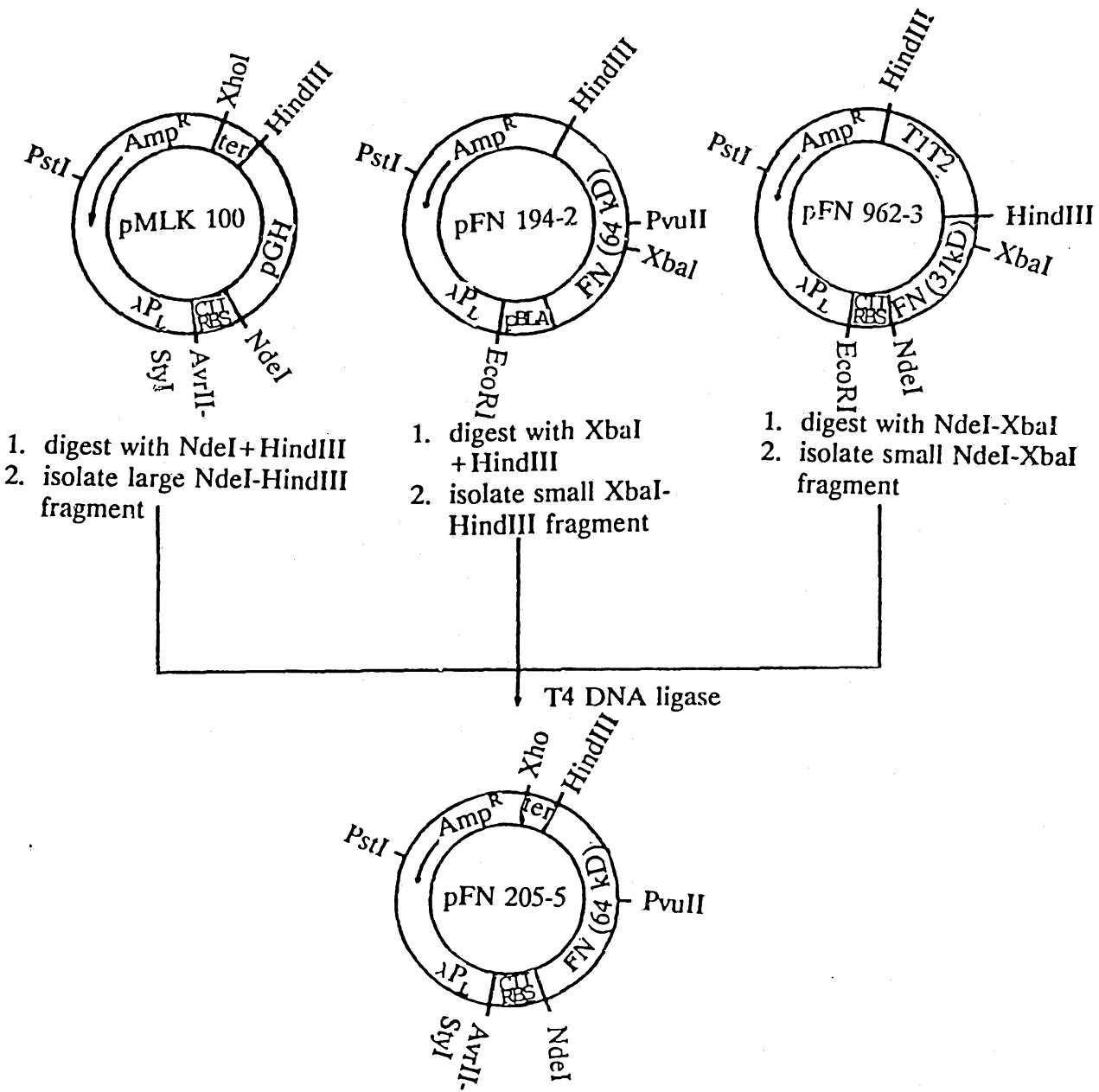
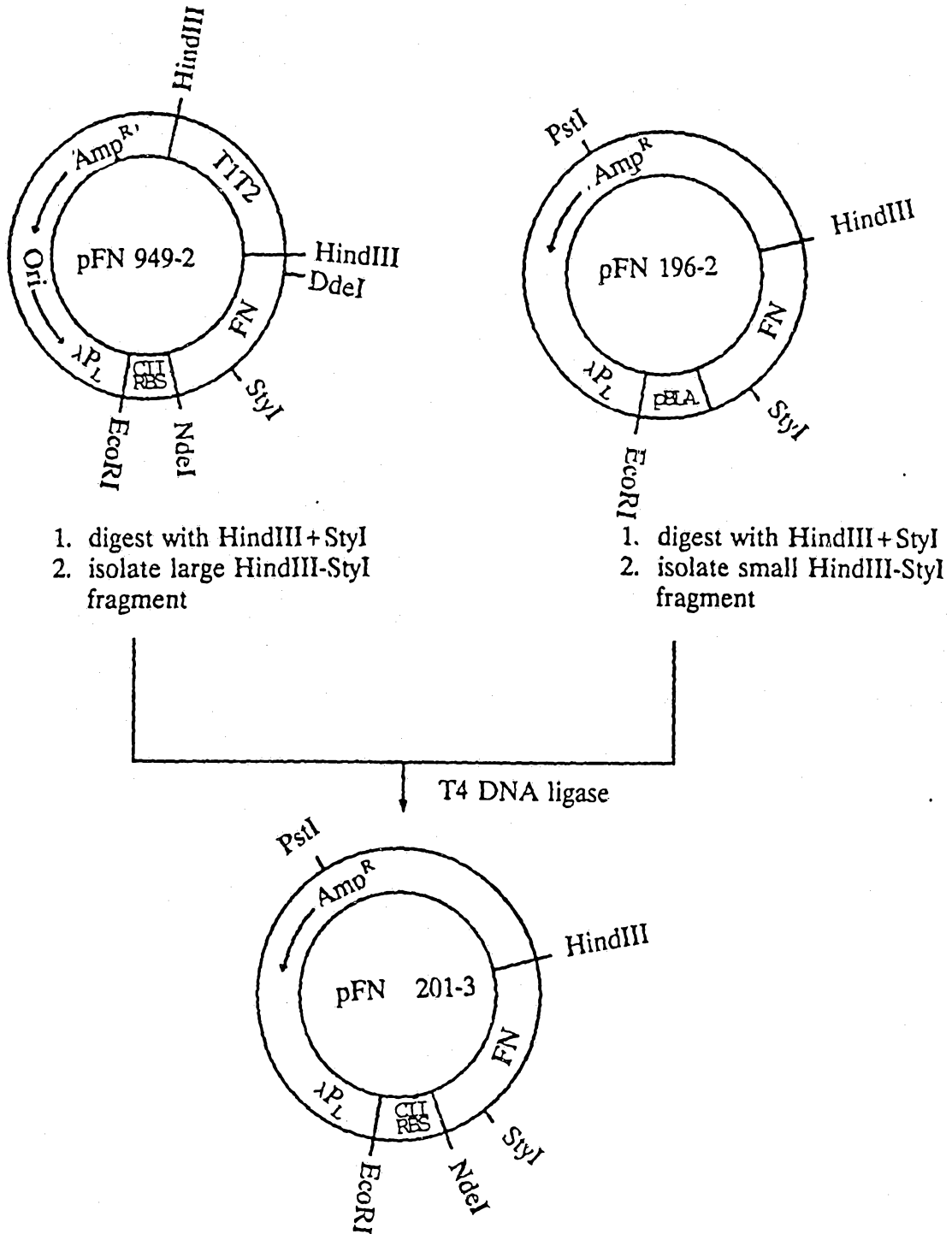
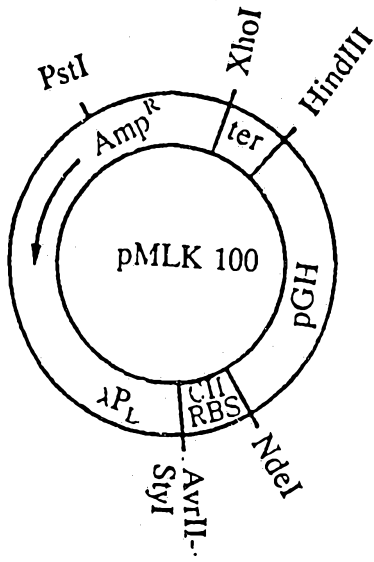

Figure 26



35/43

Figure 27



- 1. digest with NdeI+HindIII
- 2. isolate large NdeI-HindIII fragment

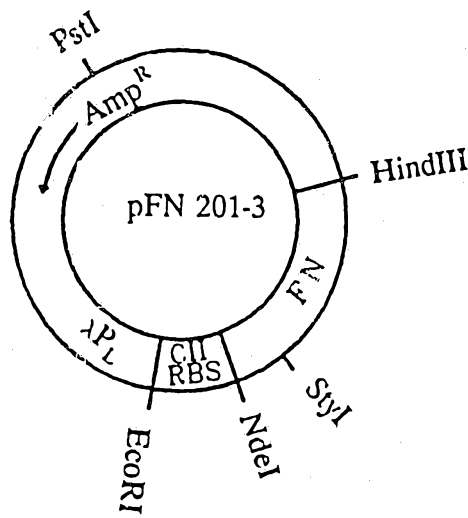

- 1. digest with NdeI+HindIII
- 2. isolate small NdeI+HindIII fragment (FN)

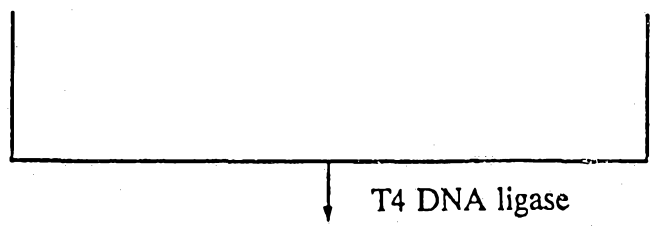

T4 DNA ligase

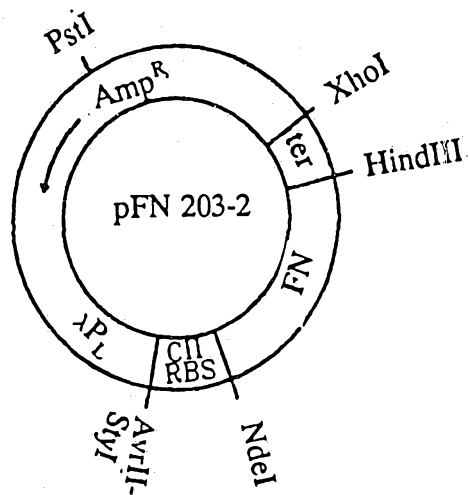
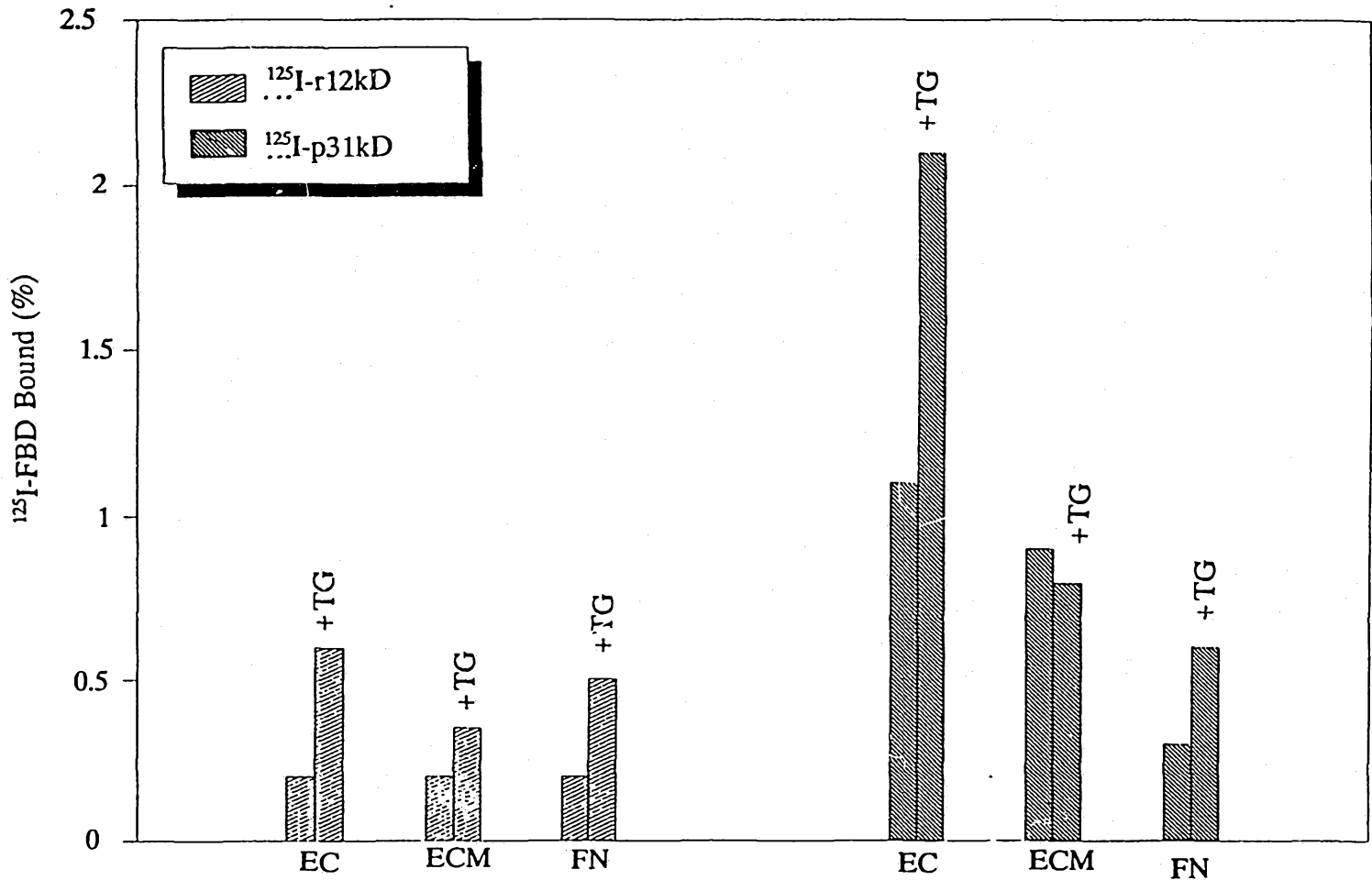
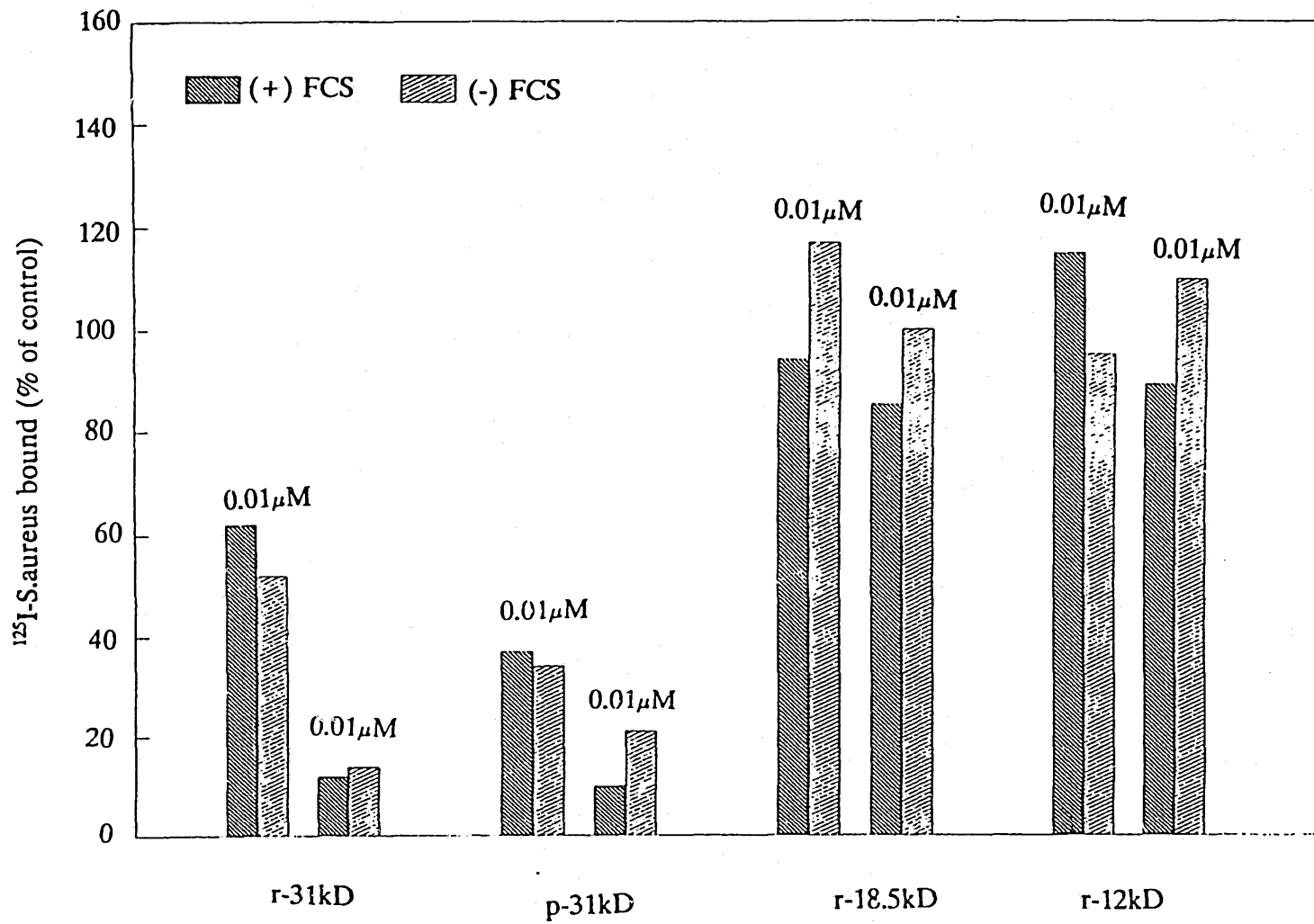

Figure 28



SUBSTITUTE SHEET

Figure 29



38/43

Figure 30

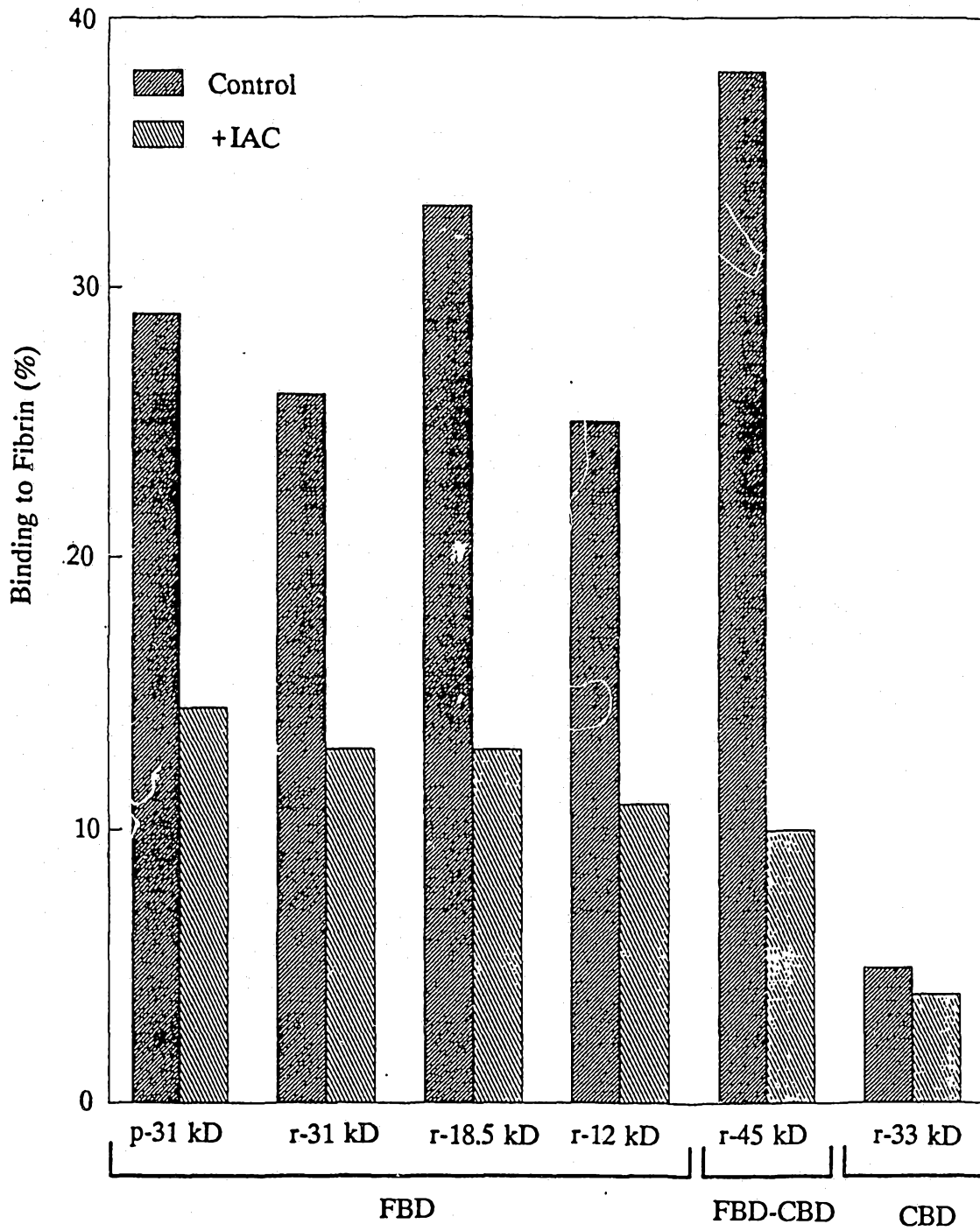

39/43

Figure 31

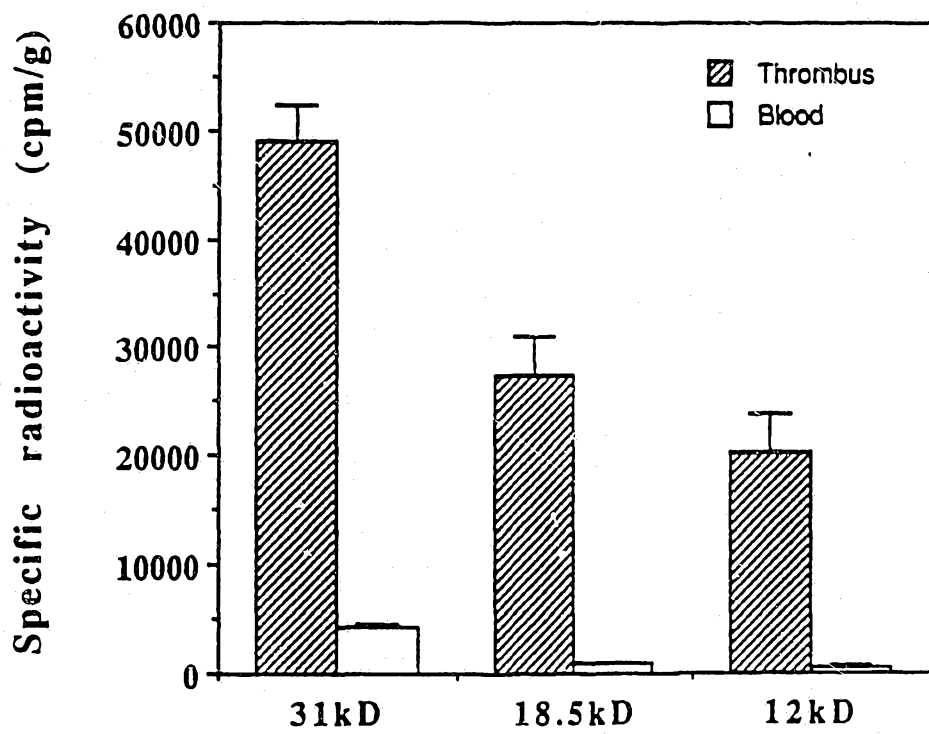

40/43

Figure 32

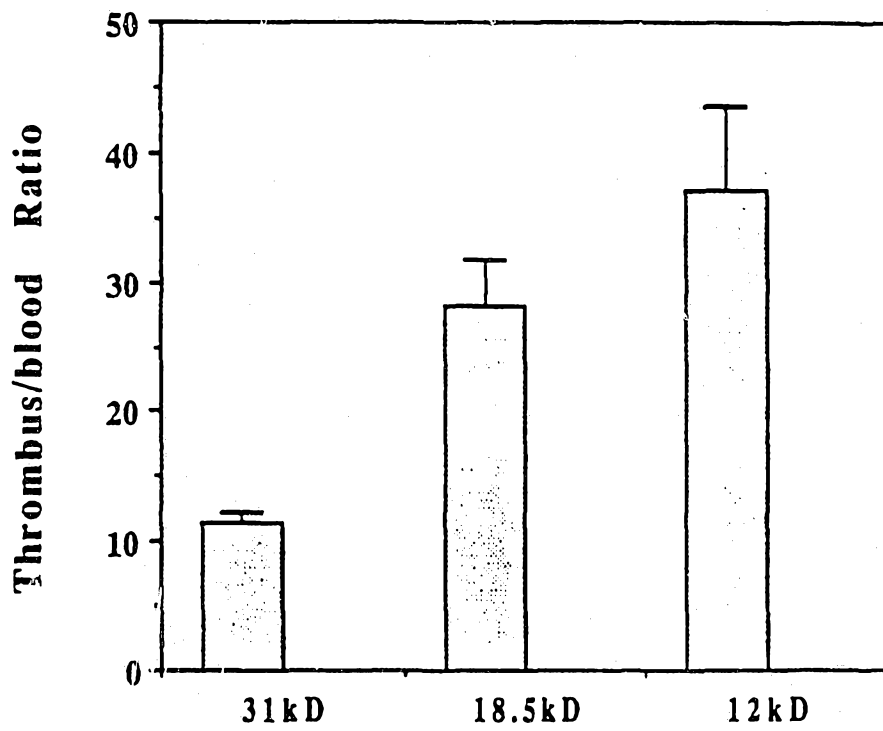
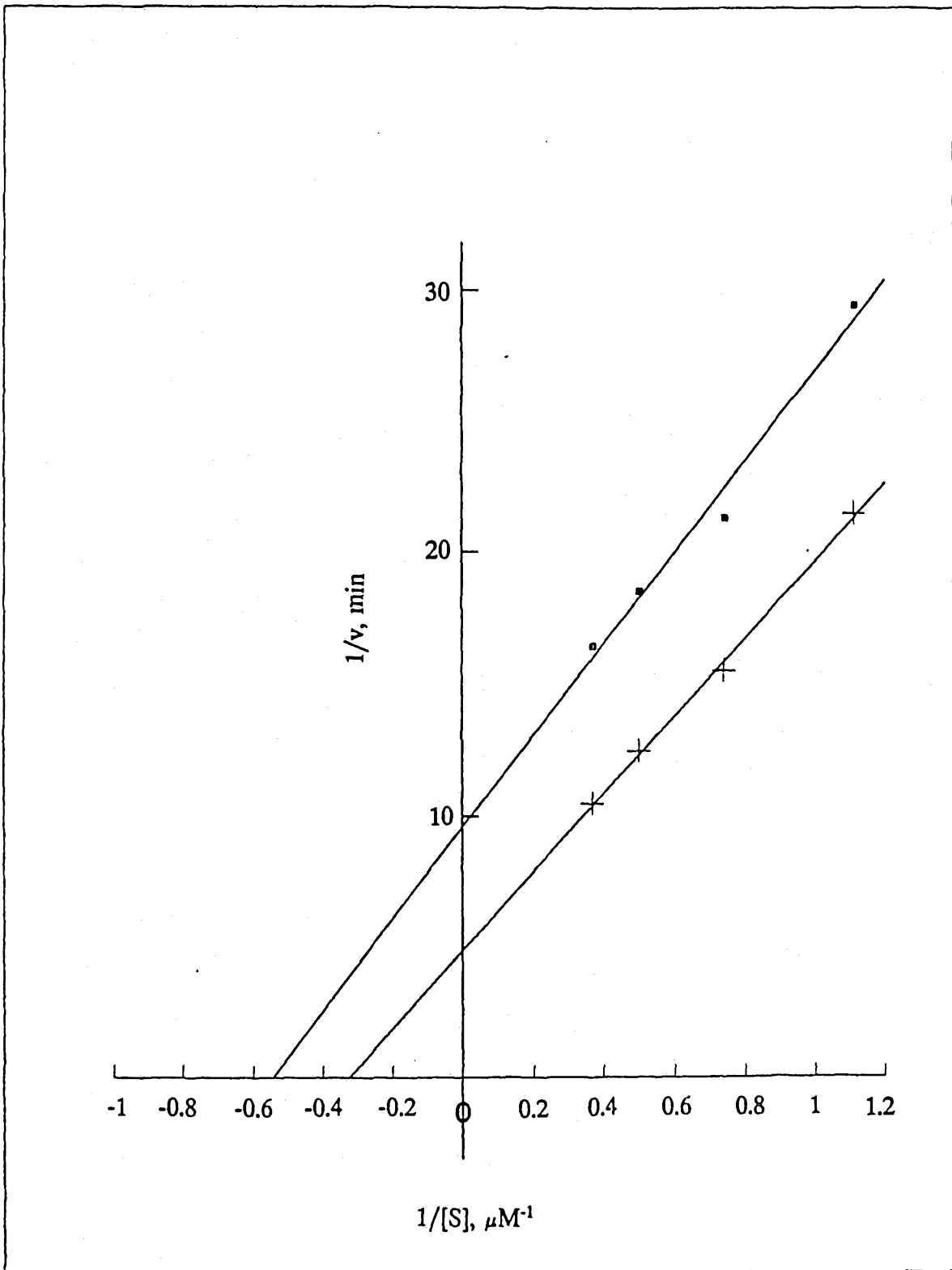
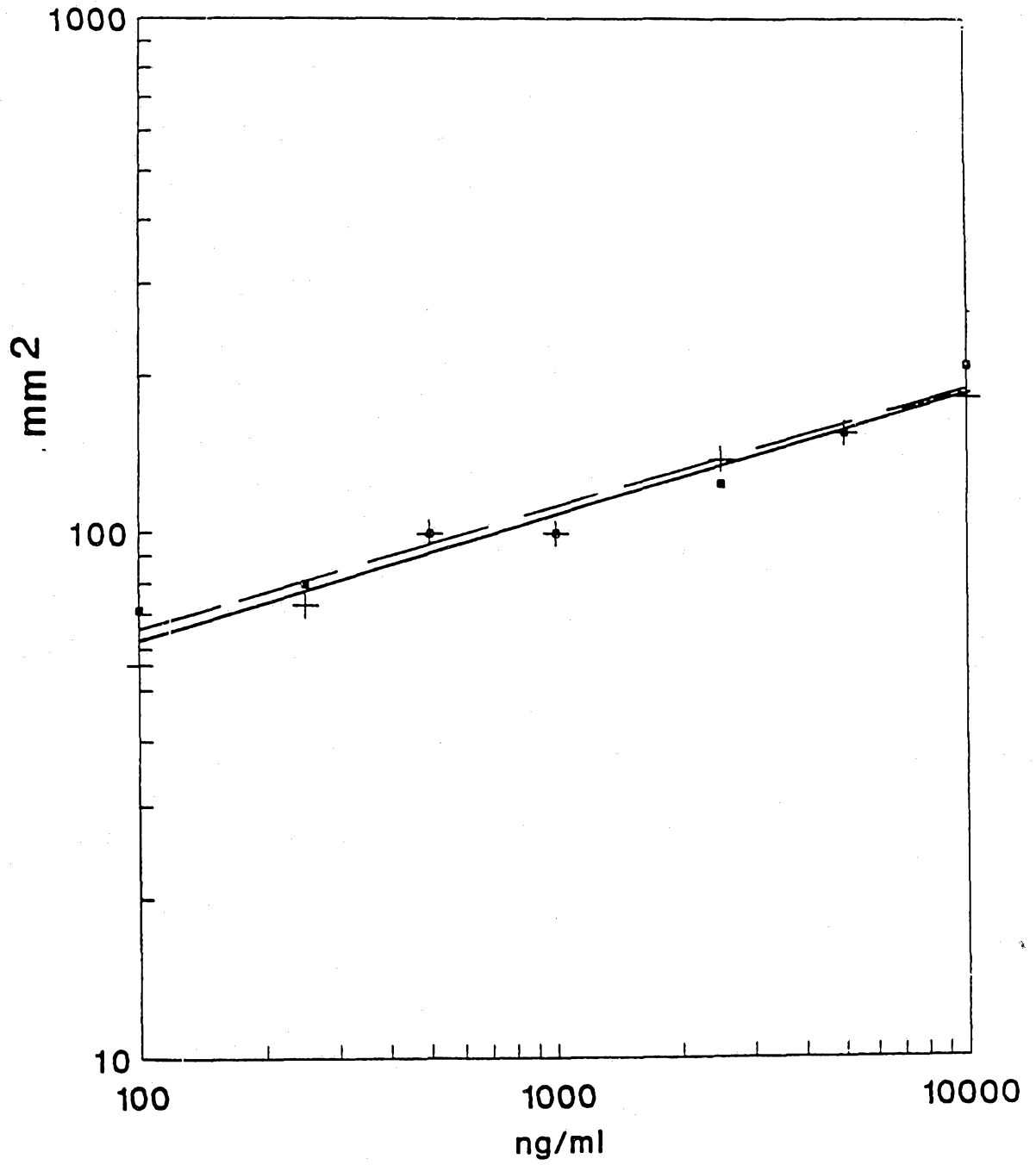

Figure 33



42/43

Figure 34



43/43

Figure 35

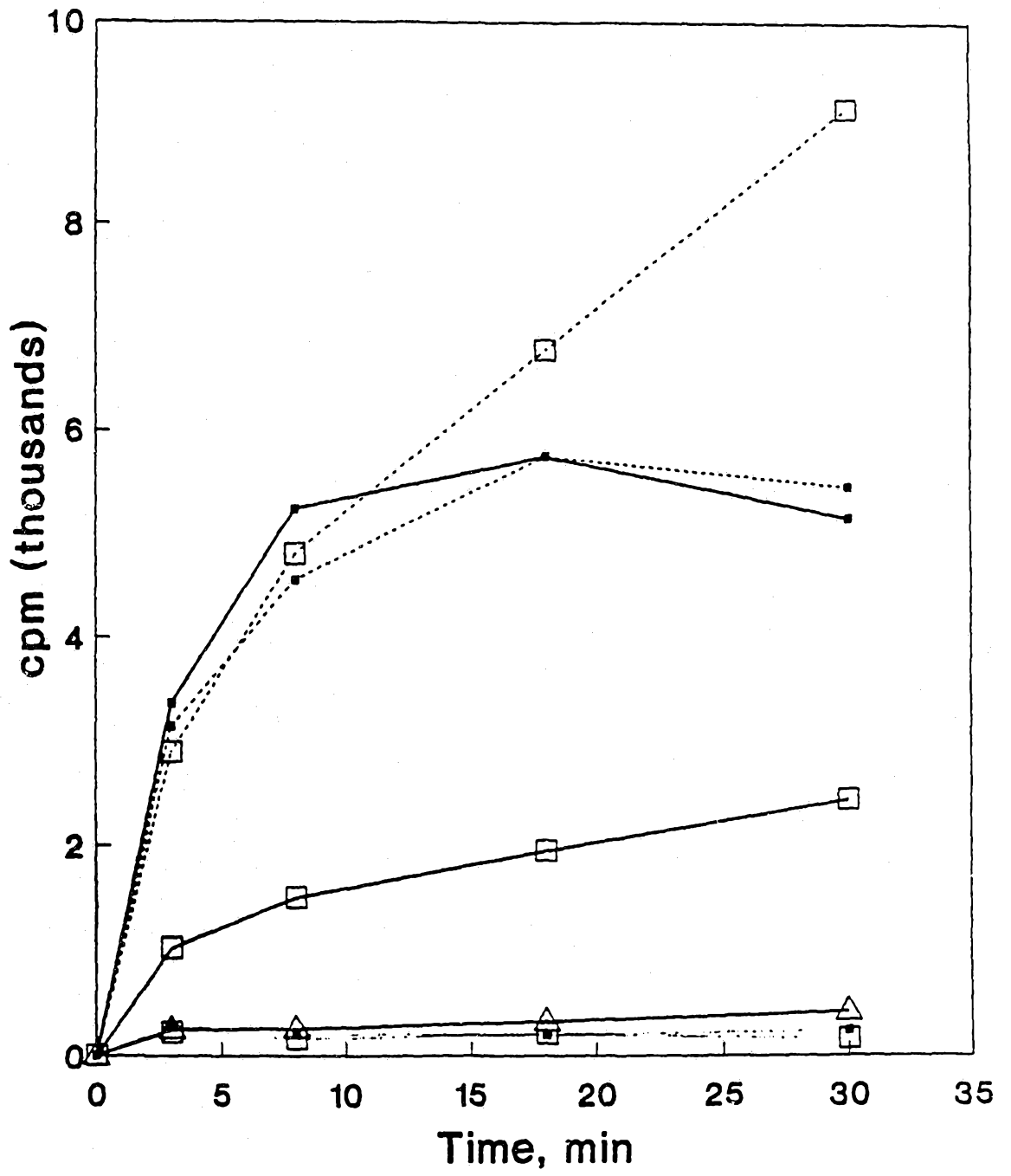

INTERNATIONAL SEARCH REPORT

International Application No. PCT/US91/03584

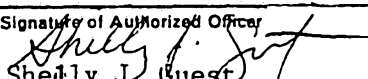
I. CLASSIFICATION OF SUBJECT MATTER (If several classification symbols apply, indicate all) ⁶		
According to International Patent Classification (IPC) or to both National Classification and IPC IPC(5): A61K 37/10; C07H 15/12; C12P 21/06; C12N 1/22 UC Class; 514/8; 435/69.1, 91, 320.1, 272.3; 530/350, 380, 413; 536/27		
II. FIELDS SEARCHED		
Minimum Documentation Searched ⁷		
Classification System	Classification Symbols	
US Class.	514/8; 435/69.1, 91, 320.1, 272.3; 530/350, 380, 413; 536/27	
Documentation Searched other than Minimum Documentation to the Extent that such Documents are Included in the Fields Searched ⁸		
III. DOCUMENTS CONSIDERED TO BE RELEVANT ⁹		
Category ¹⁰	Citation of Document, ¹¹ with indication, where appropriate, of the relevant passages ¹²	Relevant to Claim No. ¹³
Y	EMBO Journal, volume 4, issued May 1985, Kornblihtt, A.R., "Primary Structure of human fibronectin: differential splicing may generate at least 10 polypeptides from a single gene," pages 1755-1759, see "Results and Discussion".	1-94
<p>¹⁰ Special categories of cited documents:</p> <p>"A" document defining the general state of the art which is not considered to be of particular relevance</p> <p>"E" earlier document but published on or after the international filing date</p> <p>"L" document which may throw doubts on priority claim(s) or which is cited to establish the publication date of another citation or other special reason (as specified)</p> <p>"O" document referring to an oral disclosure, use, exhibition or other means</p> <p>"P" document published prior to the international filing date but later than the priority date claimed</p> <p>"T" later document published after the international filing date or priority date and not in conflict with the application but cited to understand the principle or theory underlying the invention</p> <p>"X" document of particular relevance; the claimed invention cannot be considered novel or cannot be considered to involve an inventive step</p> <p>"Y" document of particular relevance; the claimed invention cannot be considered to involve an inventive step when the document is combined with one or more other such documents, such combination being obvious to a person skilled in the art.</p> <p>"&" document member of the same patent family</p>		
IV. CERTIFICATION		
Date of the Actual Completion of the International Search	Date of Mailing of this International Search Report	
09 September 1991	24 SEP 1991	
International Searching Authority	Signature of Authorized Officer	
ISA/US	 Shelly J. Guest	