

Aug. 2, 1938.

H. W. BIRK  
RECEPTACLE

2,125,419

Original Filed Jan. 14, 1936

*Fig. 1*

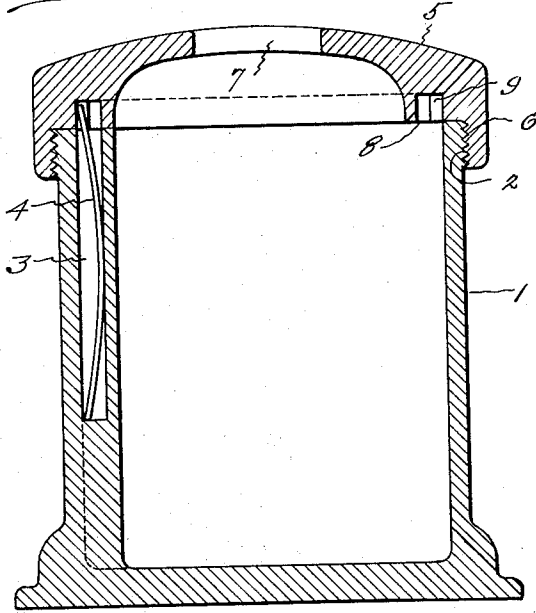

*Fig. 2*

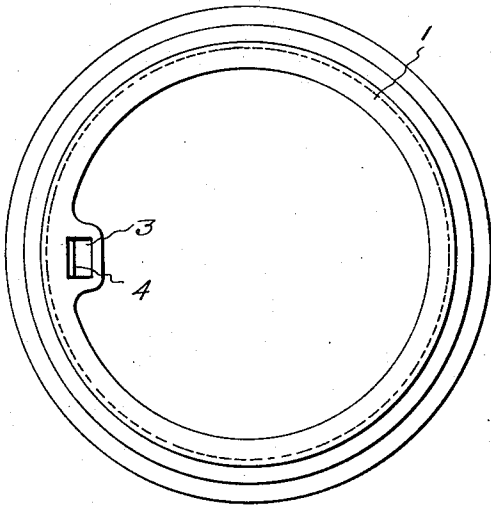

*Fig. 3*

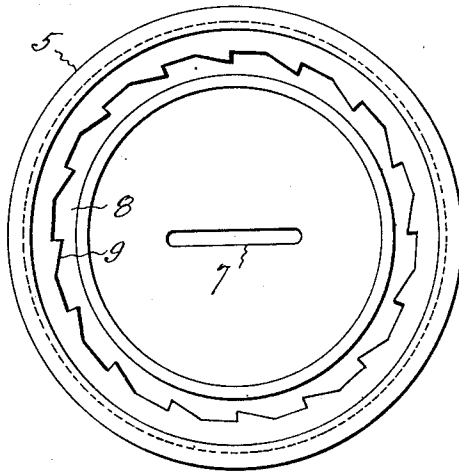

*Fig. 4*

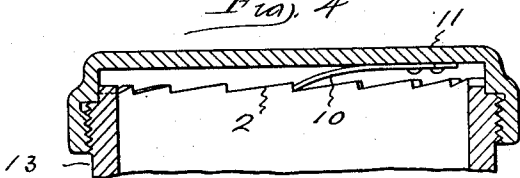

INVENTOR  
Harold W. Birk, by  
Henry P. Williams  
att.

# UNITED STATES PATENT OFFICE

2,125,419

## RECEPTACLE

Harold W. Birk, East Hartford, Conn.

Application January 14, 1936, Serial No. 59,033

Renewed February 2, 1938

7 Claims. (Cl. 206—1.5)

This invention relates to receptacles which have closures that are automatically locked when closed and that cannot be detached without knowledge of the peculiarity of the locking means.

5 The object of the invention is to provide a very simple and inexpensive automatic closure locking means which will readily release the closure when subjected to the proper influences.

10 The concept of the invention is the provision between a receptacle and its closure of thermo-responsive means that under normal temperature conditions permits the closure to be readily applied to the receptacle and to be automatically locked against removal, but when subjected to abnormal temperature conditions, either higher or lower as the construction requires, will assume such a form that the closure will automatically be unlocked so that it may be easily removed.

15 The invention in its simplest form being applicable to coin receiving savings banks it is illustrated and described herein in connection with such a use.

20 In the accompanying drawing Fig. 1 is a central vertical section of a coin bank with its closure locked after the manner of this invention.

25 Fig. 2 is a view of the receptacle with the closure removed.

Fig. 3 is a view looking into the closure.

30 Fig. 4 is a section showing a modified arrangement of the locking means.

In the views 1 indicates a receptacle which may have any desired configuration and may be made of composition or metal suitably finished and ornamented. The receptacle shown is cylindrical with an open top and an exterior thread 2 around the upper end. The receptacle wall at one side has a pocket 3 in which is a strip 4 of thermo-responsive metal. This strip is somewhat curved and its upper end extends above the top of the receptacle. It is not essential that the thermo-responsive strip be located in a pocket, but this is preferable in a toy bank so that the strip will be protected from coin which might affect its action.

35 The closure 5 first illustrated around its edge has an interior thread 6 which is designed to fit the exterior thread 2 around the upper end of the receptacle, and through its top a coin slot 7. In an annular channel 8 in the closure are a series of teeth 9.

40 When the closure is screwed on the receptacle the upper end of the thermo-responsive strip 4 engages the teeth 9 and these elements act as a pawl and ratchet which allow the closure to be

freely screwed upon the receptacle but obstruct the removal of the closure from the receptacle.

The closure can be unlocked, however, by subjecting the device to an abnormal temperature which will cause the thermo-responsive strip to straighten out so that its upper end will be carried out of engagement with the ratchet teeth.

5 If the strip is arranged in one relation and the temperature is raised, as by placing the device in hot water, or on a radiator, or above a gas flame, or over an electric heater, it will straighten and release the closure. Should the strip be reversed it may be straightened for releasing the closure by setting the device in ice water or in a refrigerator, which will lower its temperature. Thus while the closure may be readily applied to the receptacle at any time, it cannot be removed unless the trick of subjecting the lock to an abnormal temperature is known.

10 Many modifications of the details of the structure, within the scope of the invention, appear possible. For instance in Fig. 4 it is shown how the thermo-responsive strip 10 could be attached to the inside of the closure 11 and shaped to engage teeth 12 in the upper edge of the receptacle 13, an arrangement reverse to that previously described.

The invention claimed is:—

1. A receptacle having a pocket in its interior, a closure for the receptacle, and a thermo-responsive strip located in said pocket and arranged to engage the closure when subjected to normal temperatures, and to become disengaged from the closure when subjected to abnormal temperatures.

2. A receptacle, a closure for the receptacle, ratchet and pawl means with one member attached to the receptacle and the other member attached to the closure, said pawl being formed of thermo-responsive metal and arranged to engage the ratchet under normal temperatures and to be disengaged from the ratchet when subjected to abnormal temperatures.

3. A portable receptacle, a closure detachably secured over an opening to said receptacle, and thermo-responsive means attached to one member and engaged with locking means on the other member, said thermo-responsive means under normal temperatures, preventing the removal of the closure and when subjected to abnormal temperatures, flexing and disengaging from said locking means and permitting the closure to be detached from the receptacle.

4. A portable receptacle, a closure detachably secured over an opening to said receptacle, and

thermo-responsive means attached to the receptacle and engaged with locking means on the closure, said thermo-responsive means, under normal temperatures, preventing the removal of the closure and when subjected to abnormal temperatures, flexing and disengaging from said locking means and permitting the closure to be detached from the receptacle.

5  
10  
15  
20  
5. A portable receptacle, a closure detachably secured over an opening to said receptacle, and thermo-responsive means attached to the closure and engaged with locking means on the receptacle, said thermo-responsive means, under normal temperatures, preventing the removal of the closure and when subjected to abnormal temperatures, flexing and disengaging from said locking means and permitting the closure to be detached from the receptacle.

6. A portable receptacle, a closure detachably secured over an opening to said receptacle, and a

thermo-responsive strip attached to one member and engaged with locking teeth on the other member, said strip, under normal temperatures, preventing the removal of the closure and when subjected to abnormal temperatures, flexing and disengaging from said teeth and permitting the closure to be detached from the receptacle.

7. A portable receptacle, a closure threaded upon said receptacle, and a thermo-responsive strip attached to one member and engaged with the other member, said engagement of the strip being such that the closure may be freely screwed upon the receptacle but restrained from being unscrewed therefrom when the strip is subjected to normal temperatures, and said strip, when subjected to abnormal temperatures, flexing and releasing said closure so that it may be unscrewed from the receptacle.

HAROLD W. BIRK. 20